

BACnet Integration Guide

i-Vu® Link/i-Vu® Open Link

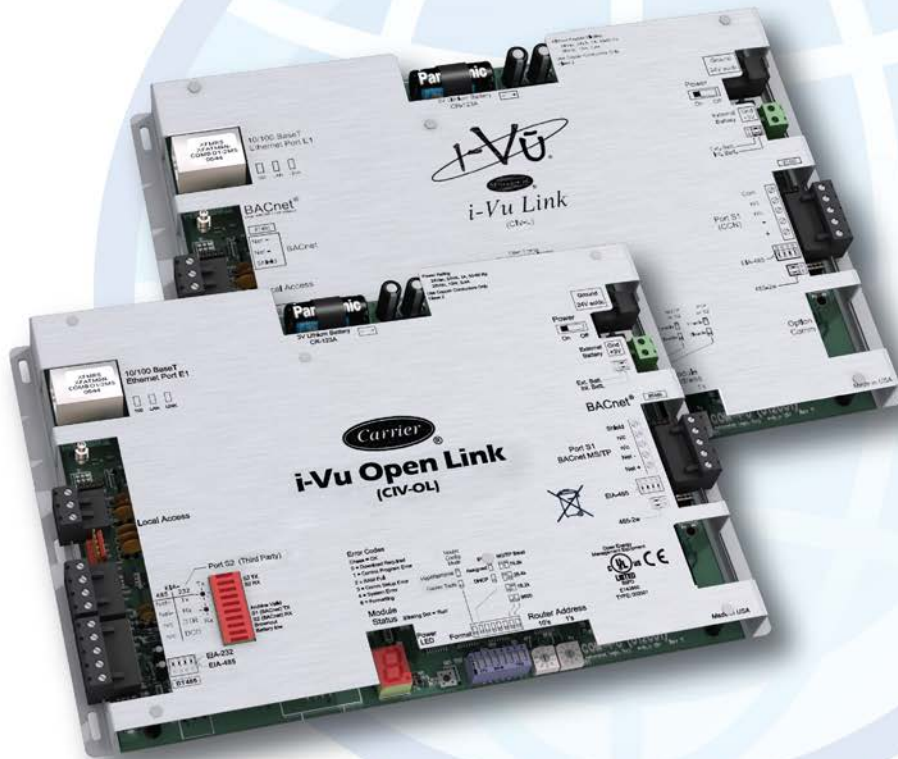

Table of Contents

Overview	1
Before-you-begin checklist.....	2
1 Connect the third-party device to the Carrier controller.....	3
To connect to a BACnet IP device	3
To wire a BACnet MS/TP device	4
2 Discover BACnet networks, devices, and objects	5
3 Create a control program in Snap.....	6
To format a BACnet address.....	6
To edit a microblock address.....	8
To set up network inputs	8
4 Download the BACnet driver and control programs.....	12
5 Set up the BACnet driver properties if using BACnet MS/TP.....	13
6 Verify the I-Vu® Link/Open Link is set up correctly.....	14
To get a diagnostic capture using Wireshark.....	15



Overview

Follow the steps in this document to integrate one or more third party BACnet controllers using an i-Vu® Link/Open Link. See the *i-Vu® Link/Open Link Installation and Start-up Guide* for installation and networking instructions.

i-Vu® Link/Open Link

Protocol port	i-Vu® Link - Port E1 or S2 i-Vu® Open Link - Port E1 or S1
Module driver	drv_ivulink_modbus_6-00-082* drv_ivuopenlink_std_6-00-082*
Read/write capability	Can read from and write to the third-party equipment

Third party

Supported equipment	Any device that supports the BACnet MS/TP (9600, 19200, 38400, or 76800) or BACnet IP protocol
---------------------	--

*You can download the latest drivers from the *Carrier Control Systems Support Site* <http://www.hvacpartners.com/>. Go to:

- The i-Vu® Link driver - **Commercial** tab > **Carrier Commercial Controls** > **CCN Products** > **i-Vu CCN Routers** > **i-Vu Link** > **Documents/Downloads**
- The i-Vu® Open Link driver - **Commercial** tab > **Carrier Commercial Controls** > **i-Vu SAL Files & Updates** > **North American Factory SAL Files.**

The i-Vu® Link driver supports BACnet devices connected to Port S2 and BACnet devices connected on the Ethernet port simultaneously.

The i-Vu® Open Link driver supports BACnet devices connected to Port S1 and BACnet devices connected on the Ethernet port simultaneously.

The third party point count for the i-Vu® Link/Open Link is the total of the 2 ports.

Before-you-begin checklist

You need the following items, information, and skills for the integration process:

-
- The BACnet device's:
 - BACnet network number
 - MAC address
 - Device instance
 - Points list, including BACnet Object ID's (object type plus object instance)
-
- The baud rate of the BACnet devices, if running MS/TP
-
- Verification that all communication settings have been set on the BACnet devices
-
- Experience creating control programs in Snap
-
- Experience installing, wiring, setting up, and downloading custom control programs to the i-Vu® Link/Open Link
-
- The latest version of *Wireshark* (<http://www.wireshark.org>) for BACnet/IP downloaded and installed. Use this network analysis tool for troubleshooting.
-

1 Connect the third-party device to the Carrier controller

An i-Vu® Link/Open Link can reference a third-party BACnet point on any network type if a BACnet route to the point exists.

NOTE Communication may be affected by the network bandwidth as well as the frequency and number of points communicating.

Scenario 1:

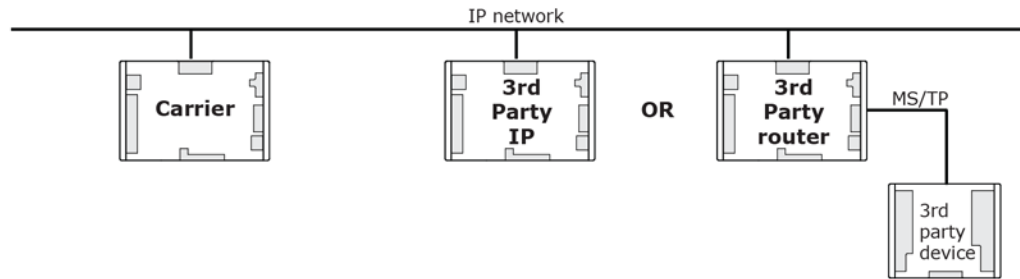

Scenario 2:

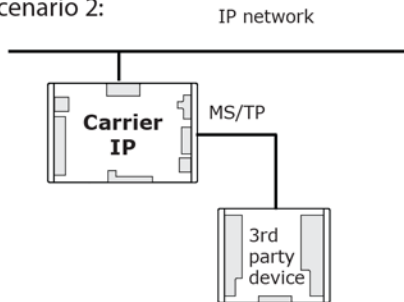

To connect to a BACnet IP device

Scenario 1

Use

- A straight-through cable to connect the i-Vu® Link/Open Link to a hub or switch, and a second straight-through cable to connect the hub or switch to a BACnet server or gateway
- Maximum cable length: 328 feet (100 meters)

To integrate a third-party BACnet IP device, or any device it routes to:

- An IP route to the point must exist.
- You must either have a Carrier IP device on the same IP subnet as the third-party device, or you must have BBMD's configured to communicate to the IP subnet where the third-party device lives.

- 1 Connect the third-party device to the Carrier controller

- 1 Turn off the power to the i-Vu® Link/Open Link.
- 2 Connect **Port E1** to the network.
- 3 Turn on the power to the i-Vu® Link/Open Link.
- 4 Ensure that the BACnet IP device is also connected to the network.

To wire a BACnet MS/TP device

Scenario 2

Use 18-24 AWG twisted, shielded pair cable for up to 2000 feet (609.6 meters).

NOTE Shielding provides noise immunity in an electrically noisy environment. Acceptable wiring types, in order of greatest to least noise immunity, are:

- 2-pair, each pair individually shielded
- 2-pair, single overall cable shield

See *MS/TP Networking and Wiring Installation Guide* for details.

- 1 Turn off the power to the i-Vu® Link/Open Link.
- 2 Check the communications wiring for shorts and grounds.
- 3 Wire to the third party device.
 - i-Vu® Link - Connect to Port S2
 - i-Vu® Open Link - Connect to Port S1 or S2
- 4 Set the jumpers for **EIA-485**. Also, if using Port S1, set the jumper to **2-wire**.
- 5 Verify that the baud rate is the same for all devices on the network segment.
- 6 Turn on the i-Vu® Link/Open Link's power.

NOTES

- Use the same polarity throughout the network segment.
- Repeaters are required for more than 31 devices. See your third-party device manufacturer's recommendations.
- To reduce communication and data errors, terminate each end of an EIA-485 network with a resistor whose value equals the network's characteristic impedance. Some third-party manufacturers provide a built-in resistor that you enable or disable with a jumper. Make sure that only devices at the end of a network have termination enabled.

EXAMPLE If an EIA-485 2-wire network's characteristic impedance is 120 Ohms, terminate one pair by placing a 120 Ohm resistor across the **Net+** and **NET-** connectors of the master. Terminate the other pair by placing a 120 Ohm resistor across the **+** and **-** connectors of the furthest slave.

- A solid receive light on the i-Vu® Link/Open Link indicates a wiring or polarity problem.

2 Discover BACnet networks, devices, and objects

The i-Vu® or Field Assistant **BACnet Discovery** feature locates all accessible BACnet networks, BACnet devices, and BACnet objects (including devices in your i-Vu® Plus or Pro or Field Assistant system) on a BACnet network.

NOTE BACnet Discovery is not available in the i-Vu® Standard application.

To use **BACnet Discovery**:

- 1 Select the system level in the navigation tree and then the **Devices** page > **Advanced** tab.
- 2 Click the **BACnet Discovery Start** button to discover BACnet sites for the system. An item called **Discovered Networks** appears in the tree. After all sites are found, close the status dialog box.
- 3 To discover BACnet networks, select **Discovered Networks**, then click **Go**. A list of all BACnet networks appears in the navigation tree. After all networks are found, close the status dialog box.



TIP Run a commstat manual command to determine which device routes to each network. The **BACnet Blind Show Network** section of the Commstat window shows the IP address of the router to each network.

- 4 To discover BACnet devices on a network, select a network in the navigation tree, then click **Go**. After all devices are found, close the status dialog box. Click ▶ beside an item to expand the list of devices.
- 5 To discover BACnet objects on a device, select the device on the navigation tree, then click **Go**. After all objects are found, close the status dialog box. A list of all BACnet objects in this device appears on the navigation tree.



TIP Make sure you are discovering objects in the correct device. It may take some time to discover objects in devices with more than 100 objects.

- 6 Optional: Do the following to export the BACnet information so that it can be used in the Snap application:
 - a) On the navigation tree, select a discovered network with devices or a single device.
 - b) Click **Export**.
 - c) Name and save the .discovery file in any folder.

NOTES

- Some third-party BACnet devices may not be discovered because they do not support the BACnet methods required for auto discovery.
- If the discovery process returns ambiguous information, such as multiple points with similar names, contact the third-party manufacturer's representative for clarification.
- Device configuration or network load can prevent the i-Vu® or Field Assistant interface from showing all BACnet devices. If you do not see a BACnet device that you expect to see, check the system's BBMD configurations. If the configurations are correct, try the discovery process again.
- If a third-party device is not discoverable, you must get the device's address and point list information from the third-party vendor. See *To format a BACnet address* (page 6).
- Troubleshooting BBMD's. See the *BBMD Utility User Guide*.

3 Create a control program in Snap

When you create your control program, use a Network I/O microblock for each third-party point.

NOTE The maximum number of control programs allowed is 199.



TIP Verify the third-party manufacturer's register addressing pattern by establishing communication with a few points whose values you can physically manipulate before you spend time addressing the remaining integration points.

To create a control program for multiple identical third-party devices

If you are integrating to multiple identical third-party devices, the i-Vu® or Field Assistant application can help you address the Network I/O microblocks.

- 1 Replicate the first device's control program for each of the other third-party devices.
- 2 Do one of the following:
 - If Network I/O microblocks were addressed in the Snap application, go to step 3.
 - If the Network I/O microblocks do not have addresses, enter the addresses in the i-Vu® or Field Assistant interface for one instance of the equipment. Do this on the equipment's **Properties** page > **Network Points** tab. Then use Global Copy to copy the addresses to all other instances of the equipment.
- 3 Go to the **Properties** page > **Network Points** tab for another instance of the equipment.
- 4 Click **Search/Replace** at the top of the **Address** column.
- 5 Replace the device identification in the addresses with the identification for the third-party device the control program will communicate with.

To format a BACnet address

Use the information below to format a valid address in each microblock that you use to read or write to a third-party point.



CAUTION!

When integrating third-party devices into a i-Vu® or Field Assistant system, most communication problems are caused by incorrect data or typing errors in the microblock's **Address** field.

Address format: **bacnet://device/object/property@priority**

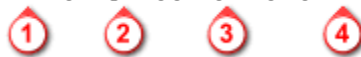

NOTE Numeric values in a BACnet address can be entered using decimal or hexadecimal notation. Type 0x before a hexadecimal value.

1	Device - Use one of the following:	EXAMPLES
	Device instance number	bacnet://2010/...
	BACnet device name	bacnet://MyDevice/...
	Network number: MAC address (of third-party device)	bacnet://1234:35/... bacnet://1234:0x23/...
	The word "this" if a network point requests a value from another control program in the same Carrier controller. Avoids network traffic. Requires v2.05 or later controller driver.	bacnet://this/...

2	Object - Use one of the following:	EXAMPLES
	Object type: Instance number (See NOTES below)	bacnet://.../ai:2
	BACnet object name	bacnet://.../MyObject

NOTES

- For object type, you may type the abbreviation (not case sensitive), the full name, or the object type number. Some standard BACnet object type numbers are listed below. See the BACnet standard for a complete list. For proprietary BACnet objects, see the object's manufacturer.

Use...	Or...	Or...
ai	analog-input	0
ao	analog-output	1
av	analog-value	2
bi	binary-input	3
bo	binary-output	4
bv	binary-value	5
dev	device	8
msi	multistate-input	13
mso	multistate-output	14
msv	multistate-value	19

- Every object in a controller has a unique instance number, regardless of its control program.

3	Property (optional) If you want to read or write a property other than present_value, type one of the following:	EXAMPLES
	BACnet property identifier	bacnet://.../.../cov_increment
	BACnet property identifier #	bacnet://.../.../22
	Property identifier (with index)	bacnet://.../.../priority-array(12)
	Property identifier # (with index)	bacnet://.../.../87(12)



TIP For standard BACnet objects, see the BACnet standard for property identifiers and property identifier numbers. For proprietary BACnet objects, see the object's manufacturer.



Priority (optional) If you want to write at a priority other than 16, type @ followed by a priority number.

Number (1-16)

EXAMPLE

bacnet://.../.../...@9

NOTE Priority levels 1 and 2 are reserved for manual and automatic life safety commands. For more information on reserved priority levels see the BACnet standard.

Examples of BACnet addresses:

bacnet://MyDevice/ai:2

bacnet://1234:0x23/analog-input:2/priority-array(12)@8

bacnet://2499:0x00E0C90047CA/bi:3

bacnet://2436:192.168.47.36:47806/0:2

To edit a microblock address

You can edit a microblock address in the following places:

- In the Snap Property Editor
- In the i-Vu® or Field Assistant interface on the microblock's **Properties** page > **Details** tab
- In the i-Vu® or Field Assistant interface on the control program's **Properties** page > **Network Points** tab

To set up network inputs

Polling or BACnet COV

If a network input or totalizer microblock's **Address** field references a BACnet object property, the microblock reads the property's value using one of the following methods.

- Polling—The microblock reads the property at the **Refresh Time** interval using the BACnet ReadProperty or ReadPropertyMultiple service (see "Method 1: Polling" below).
- BACnet COV (Change of Value) subscription—The microblock subscribes with the target BACnet object. An analog target notifies the microblock if the target's value changes by more than the target's BACnet COV_Increment. A binary target notifies the microblock when it changes state (see "Method 2: BACnet COV subscriptions" below).

Method 1: Polling

- | | |
|------------------|--|
| Benefits | <ul style="list-style-type: none"> • Allows rapid detection of a dead device or of network problems • Does not require additional memory |
| Drawbacks | <ul style="list-style-type: none"> • Generates unnecessary network traffic if a value does not change frequently • Misses value changes that occur between pollings • Can overwhelm the target's controller if many microblocks request the same property value (such as outside air temperature). The BACnet object must send the value to each microblock that polls for that data. |
| To set up | Set the microblock's Refresh Time to 30 seconds or less. |

NOTE The microblock will not poll at a **Refresh Time** interval smaller than 1 second.

BACnet ReadProperty and ReadPropertyMultiple services

See the BACnet specification for details on the ReadProperty and ReadPropertyMultiple services.

ReadPropertyMultiple occurs if:

- two or more microblocks in a controller read more than one target in the same remote controller,
- the **Refresh Time** in two or more microblocks expires at the same time, and
- the remote controller supports the service.

Method 2: BACnet COV subscriptions

- | | |
|------------------|--|
| Benefits | <ul style="list-style-type: none"> • Can decrease network traffic by preventing unnecessary updates if the target's COV_Increment is set appropriately. See step 2 in "To set up" below. |
| Drawbacks | <ul style="list-style-type: none"> • Can generate excessive network traffic if the target's COV_Increment property is too small. See step 2 in "To set up" below. • Can delay detection of a dead device or of network problems |
| To set up | <ol style="list-style-type: none"> 1 Set the microblock's Refresh Time to 31 seconds or more. 2 If the microblock's Address field references an analog property, set the target's COV_Increment property to the smallest amount by which the value must change for the target to notify its subscribers. The optimal COV_Increment is large enough to prevent unnecessary updates but small enough to be useful to the control program(s) receiving the updates. |

NOTE If COV subscription fails, the microblock reads the value at the **Refresh Time** interval using the BACnet ReadProperty or ReadPropertyMultiple service. See "Method 1: Polling" above.

COV subscription details

When an input (network input or totalizer microblock) subscribes with a BACnet target (object property), the input sets a 21-minute subscription Lifetime in the target. The target responds with a COV notification that includes the target's value and time remaining from the original subscription Lifetime (TimeRemaining). The input resubscribes with the target every 10 minutes to keep the target's BACnet subscription service active. i-Vu® or Field Assistant shows the time remaining until the input's next subscription in the **Next Refresh** field on the input's i-Vu® or Field Assistant **Properties** page.

The target also sends a COV notification that includes the target's value and subscription Lifetime TimeRemaining when the target's value changes by more than the target's COV_Increment.

If the Carrier target has one subscriber, the target sends COV notifications directly to that subscriber. If the Carrier target has more than one subscriber, it broadcasts its COV notifications to optimize network traffic. A third-party subscriber can participate in this broadcast scheme by subscribing for Unconfirmed COV notifications with a Process ID of 0. Otherwise, the Carrier target maintains and responds to the third-party subscription separately with its own Lifetime timer.

3 Create a control program in Snap

The Carrier input compares the TimeRemaining value in each COV notification broadcast the target sends to its (Next Subscription time + 11) to determine whether another input has subscribed since it did. If another input has subscribed more recently, the input adds 10 minutes to its **Next Refresh** time. This allows the COV Subscription request from the last subscribing input to keep the subscription service active for all subscribers to the same data.

EXAMPLE

Elapsed time (minutes)	Action	Target Lifetime TimeRemaining (minutes)	Input 1 Next Subscription (minutes)	Input 2 Next Subscription (minutes)
0	Input 1 subscribes to target	21 (Input 1)	10	
0	Target broadcasts COV notification because Input 1 subscribed	21	$21 \leq 10 + 11$, so keep current value of 10	
2	Input 2 subscribes to target	21 (Input 2)	$10 - 2 = 8$	10
0	Target broadcasts COV notification because Input 2 subscribed	21	$21 > 8 + 11$, so add 10 to current value of 8 $8 + 10 = 18$	$21 \leq 10 + 11$, so keep current value of 10
3		$21 - 3 = 18$	$18 - 3 = 15$	$10 - 3 = 7$
0	Target broadcasts COV notification because value changed	18	$18 \leq 15 + 11$ so keep current value of 15	$18 \leq 7 + 11$ so keep current value of 7
7		$18 - 7 = 11$	$15 - 7 = 8$	$7 - 7 = 0$ resubscribe
0	Input 2 resubscribes	21 (Input 2)	8	10
0	Target broadcasts COV notification because Input 2 subscribed	21	$21 > 8 + 11$, so add 10 to current value $8 + 10 = 18$	$21 \leq 10 + 11$, so keep current value of 10

Input 2 keeps the subscription service active at the target with a minimum of network traffic.

NOTE If an input receives COV notification with a target TimeRemaining < 11, which could happen if the last subscribing input loses communication with the target, the input resubscribes immediately.

COV notification rate

COV notifications from a BACnet object property are controlled by that property's BACnet COV_Increment. When the absolute value of the difference between the property's Present_Value and the value sent in the last COV notification is greater than the COV_Increment, the object broadcasts a COV notification. For Carrier controllers, the rate of notifications is further limited by two internal processes.

- 1 The control program's execution rate determines how often the check against COV_Increment is performed.
- 2 The controller's pending COV Notification task has built-in delays to prevent COV notifications from consuming the controller's CPU processing time.

The built-in delays are as follows:

If more than 15 COV notifications are pending delivery, the controller inserts a 50 millisecond delay after each set of 15 notifications. Once the entire list of pending notifications is serviced, the controller inserts another 50 millisecond delay. This results in a maximum COV notification rate of 300 COV notifications per second per Carrier controller.

4 Download the BACnet driver and control programs

- 1 If you do not already have the latest SAL library or drivers, download it from *Carrier Control Systems Support Site* <http://www.hvacpartners.com/> and save it to your computer.

To apply the SAL in the i-Vu interface:

- 1 Click **Main Menu** , then select **System Options** tree > **Update** tab.

NOTE Expand **Current Libraries (.sal)** to see the current SAL libraries and their revision. Compare them to what you downloaded and determine if any of them need updating.

- 2 Click  and browse to the updated .sal file that you have saved on your computer, select the file, and click **Open**.

- 3 Click **Continue**.

- 4 When process is complete, the message appears **File added successfully**.

- 5 Click **Close**.

NOTE These changes are not applied until you have updated routers and controllers.

- 1 In i-Vu® or Field Assistant's navigation tree, Right-click the router that you wish to update and click **Driver Properties**.

- 2 Select **Properties** page > **Update** tab.

- 3 If the database contains 2 or more routers, you must check **Change for all control programs of this type** in the **Controller** section.

- 4 Click **Update**. A message appears **Changes the driver and screen file to use the current library version. Continue?**

NOTE If more than one router exists, the additional routers are listed below the **Update** button.

- 5 Click **OK**.

- 6 Click **Accept**.

- 7 Continue to update any other necessary devices.

5 Set up the BACnet driver properties if using BACnet MS/TP

In the i-Vu® Open Link, check the two DIP switches at the far right to ensure that the MS/TP baud rate is set correctly.

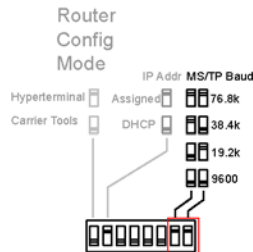

MS/TP Station ID - Defines the MS/TP MAC address of the i-Vu® Link/Open Link on the MS/TP network.

In order to check or change BACnet MS/TP polling parameters:

- 1 In the i-Vu® or Field Assistant navigation tree, right-click on the i-Vu® Link/Open Link and select **Driver Properties > Device**.
- 2 Under **Configuration**, review the settings for **Max Masters** and **Max Info Frames**.

Max Masters - defines the highest MS/TP Master MAC address on the MS/TP network.

For example, if there are 3 master nodes on an MS/TP network, and their MAC addresses are 1, 8, and 16, then Max Masters would be set to 16 (since this is the highest MS/TP MAC address on the network).

This property optimizes MS/TP network communications by preventing token passes and “poll for master” requests to non-existent Master nodes.

In the above example, MAC address 16 knows to pass the token back to MAC address 1, instead of counting up to MAC address 127. Each MS/TP master node on the network must have their Max Masters set to this same value. The default is 127.

Max Info Frames - defines the maximum number of responses that will be sent when the i-Vu® Link/Open Link receives the token. Any positive integer is a valid number. The default is 10 and should be ideal for the majority of applications. In cases where the i-Vu® Link/Open Link is the target of many requests, this number could be increased as high as 100 or 200.

6 Verify the i-Vu® Link/Open Link is set up correctly

- 1 On i-Vu® or Field Assistant's navigation tree, select the third party controller.
- 2 Select the **Properties** page > **Network Points** tab.

If...	Then...
You see the point value you expect with no errors in the Error column	You have successfully established communication with the third-party device.
All points show question marks instead of values	The i-Vu® or Field Assistant application is not communicating with the i-Vu® Link/Open Link. Troubleshoot communications. See the <i>i-Vu® Link or i-Vu® Open Link Installation and Start-up Guide</i> .
The point name is red	Look in the Error column for one of the following error codes and descriptions. <ul style="list-style-type: none"> • 1 - Communications Disabled for this Microblock Enable the integration point's Communications Enabled field on i-Vu® or Field Assistant's Network Points tab. • 3 - Address Error - Unknown Protocol Specified Verify that Address in the integration point is correct.
A value is incorrect	Verify that: <ul style="list-style-type: none"> • The Address in the integration point is correct. • The retrieved value is scaled properly, if necessary. For example, scaled from Celsius to Fahrenheit. Refer to the third-party manufacturer's documentation for scaling information.

If the above solutions do not resolve the problem, gather the following information for technical support:

- A diagnostic capture. See next topic.
- A screenshot of the **Driver Properties** - right-click on the third-party controller in the navigation tree, select **Driver Properties** > **Properties** page > **BACnet MS/TP** > **Properties** page
- A screenshot of the controller's **Properties** page > **Network Points** tab, showing addresses and errors

To get a diagnostic capture using Wireshark

Use Wireshark, a network analysis tool, to capture the Ethernet communication between the i-Vu® Link/Open Link and the BACnet device. Download the latest release of Wireshark and WinPcap from the *Wireshark website* (<http://www.wireshark.org>). Install WinPcap first, then Wireshark. Use the installation wizard's default settings.

NOTE We recommend using a hub along with Wireshark to ensure that Wireshark captures all relevant messages. Disconnect the LAN cable from the i-Vu router that you are monitoring and plug that into the **Uplink** port of the hub. Connect the computer, running Wireshark and the i-Vu router into the hub.

To run Wireshark and capture IP traffic

- 1 Click **Start > All Programs > Wireshark**.
- 2 From the menu bar, select **Capture > Interface List**.

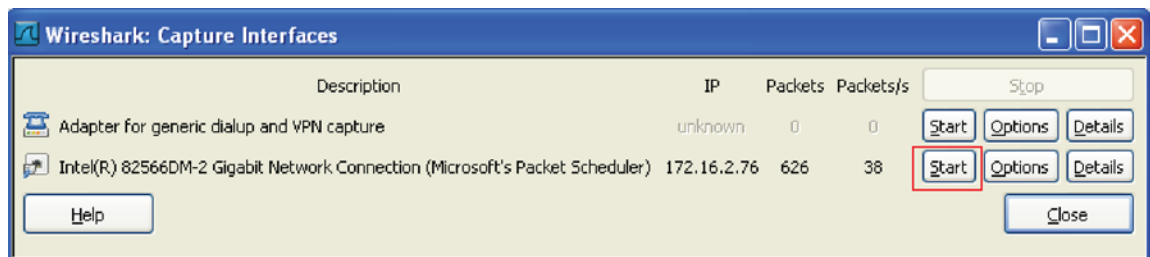

- 3 Click the **Start** button next to the adapter that is connected to the network. This starts the IP capture.



TIP Choose the adapter that shows the **Packet** value changing. This indicates the interface is active on the LAN.

- 4 Allow the capture to run long enough to ensure that there is sufficient data to allow a technician to review the problem.

To save the Wireshark capture

- 1 On the menu bar, select **Capture > Stop** to stop the data capture.
- 2 Select **File > Save** and save the capture to a convenient location. Do not change **Save as type** default, which is "Wireshark/tcpdump/... - libpcap (*.pcap, *.cap)".
- 3 Email the capture file to Carrier Technical Support for further analysis.



CARRIER CORPORATION ©2014

A member of the United Technologies Corporation family · Stock symbol UTX · Catalog No. 11-808-357-01 · 4/22/2014