

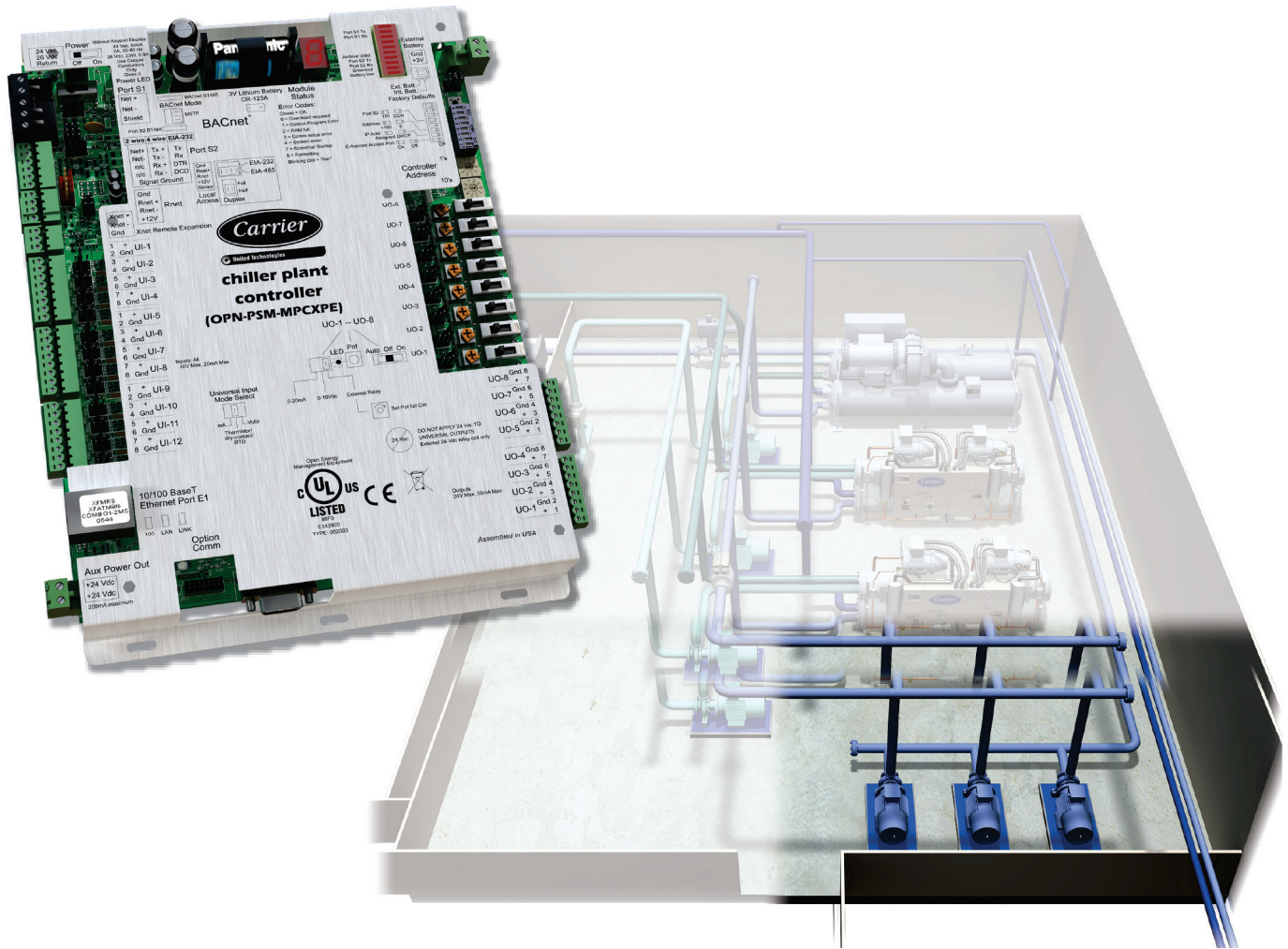

United Technologies
turn to the experts

Carrier® ChillerVu™ Variable Flow Condenser Pump Application Guide





Verify that you have the most current version of this document from www.hvacpartners.com or your local Carrier office.

Important changes are listed in **Document revision history** at the end of this document.

CARRIER CORPORATION ©2016. All rights reserved throughout the world. i-Vu is a registered trademark of Carrier Corporation. BACnet is a registered trademark of ASHRAE. All other trademarks are the property of their respective owners.

Contents

What is the Carrier® ChillerVu™ variable flow condenser water pump application?.....	1
Theory of operation	3
Variable flow, headered condenser pump control sequence.....	4
Points and Properties.....	5
Manager Status.....	5
Staging of pumps	6
Staging Trip Points and Delays.....	7
Pump VFD Control - Differential Pressure Control Loop.....	7
Individual Pump Control - Configuration	9
Common CW Entering Temperature	10
Individual CW Flow Valve Control	10
Individual Chiller Flow Configuration - Chiller Flow Meter.....	11
Individual Pump Control - Configuration	13
Variable flow, dedicated condenser pumps control sequence	14
Points and Properties.....	15
Manager Status.....	15
Common CW Entering Temperature	16
Individual Pump Control - Configuration - Pump Control	16
Individual Pump Control - Configuration - Pump VFD Control.....	18
Individual Pump Command Points - Configuration.....	19
Optional Flow Meter Properties	20
Compliance	21
FCC Compliance.....	21
CE Compliance	21
Document revision history	22

What is the Carrier® ChillerVu™ variable flow condenser water pump application?

The variable flow condenser pump sequence, available for both headered and dedicated pump arrangements, allows you to stage up to 8 VFD-equipped condenser water pumps.

NOTES

- Each pump must be equipped with a flow check valve device (or 2-position isolation valve) to prevent reverse flow through pumps that are not currently operating.
- Currently, the dedicated pump sequence supports equal- or dissimilar-sized pumps. The headered version supports only equal-sized pumps, but dissimilar-sized pump logic will be available in a future release.

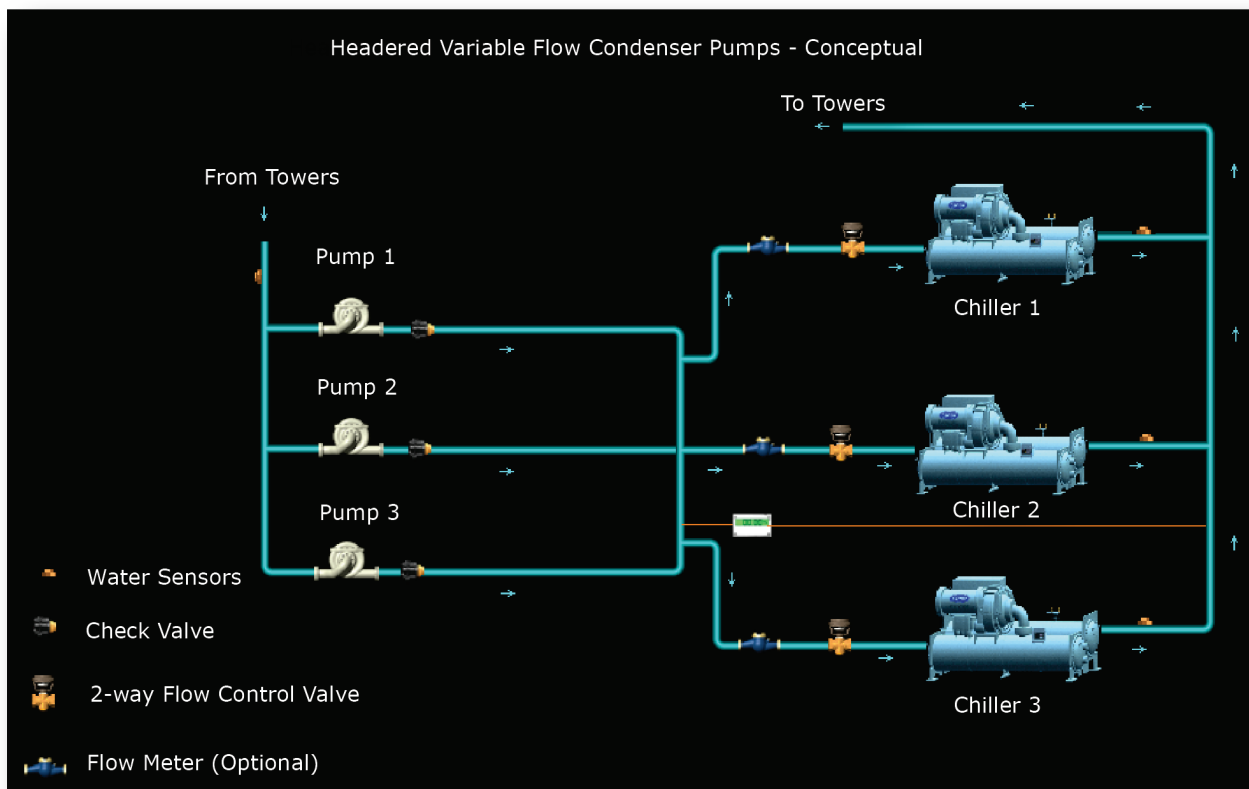

What is the Carrier® ChillerVu™ variable flow condenser water pump application?

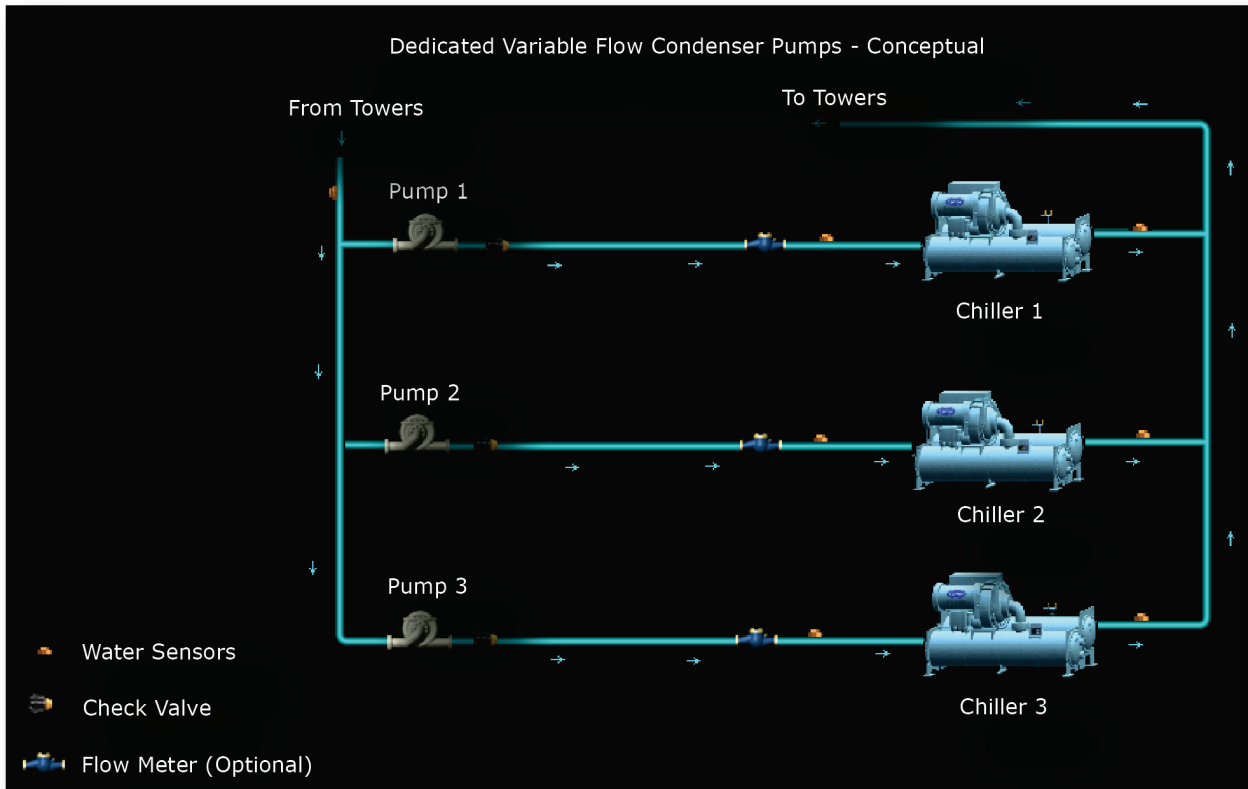

⚠ CAUTION You can use the following applications and equipment files with the Carrier® ChillerVu™ controller ONLY.

You can find detailed information on the capabilities of the Carrier® ChillerVu™ hardware in the *Carrier® ChillerVu™ Installation and Start-up Guide* (#11-808-532-01).

Theory of operation

This theory of operation is based on the fact that condenser water Delta temperature (Delta T) across the condenser barrel varies with the water flow rate through the condenser barrel.

- The Variable Flow Condenser Loop Pump sequence saves condenser pump energy by reducing condenser water flow through the chiller as machine load decreases.
- Each chiller will have a design Delta T that represents the temperature rise through the condenser at full load and the design condenser water flow rate. Varying the water flow rate as the load decreases, so that the Delta T is maintained at the design value, can reduce pump energy consumption, while allowing the machine to operate within its specified design parameters for heat rejection. You can set minimum and maximum pump speeds and/or flow rates to ensure that maximum flow rate is never exceeded and a minimum flow rate is maintained.

Example A machine with a 10°F water temperature rise across the condenser barrel, under design conditions, might only have a 5°F rise at 50% load, if condenser water flow remains constant. By reducing the condenser water flow in response to reduced Delta T, and causing it to increase to the original design delta T of 10°F, directly reduces pump energy consumption.

- The system is designed to operate independently of tower control logic. During design conditions with high outdoor wet bulb temperatures and high entering condenser water temperatures, the system has a safety override that controls the pump VFD to maintain a maximum leaving condenser water temperature setpoint, if the entering water temperature plus the delta T exceeds this value.

This causes the VFD to operate at higher speeds when the entering water is very high, or greater than the allowable limit according to the machine design, and permits maximum flow through the condenser barrel, until the leaving water temperature is brought down below the maximum setpoint. Once the entering condenser temperature is below the specified high limit, the pumps' speeds and/or flow control valves will again modulate to maintain the Delta T setpoint.

Variable flow, headered condenser pump control sequence

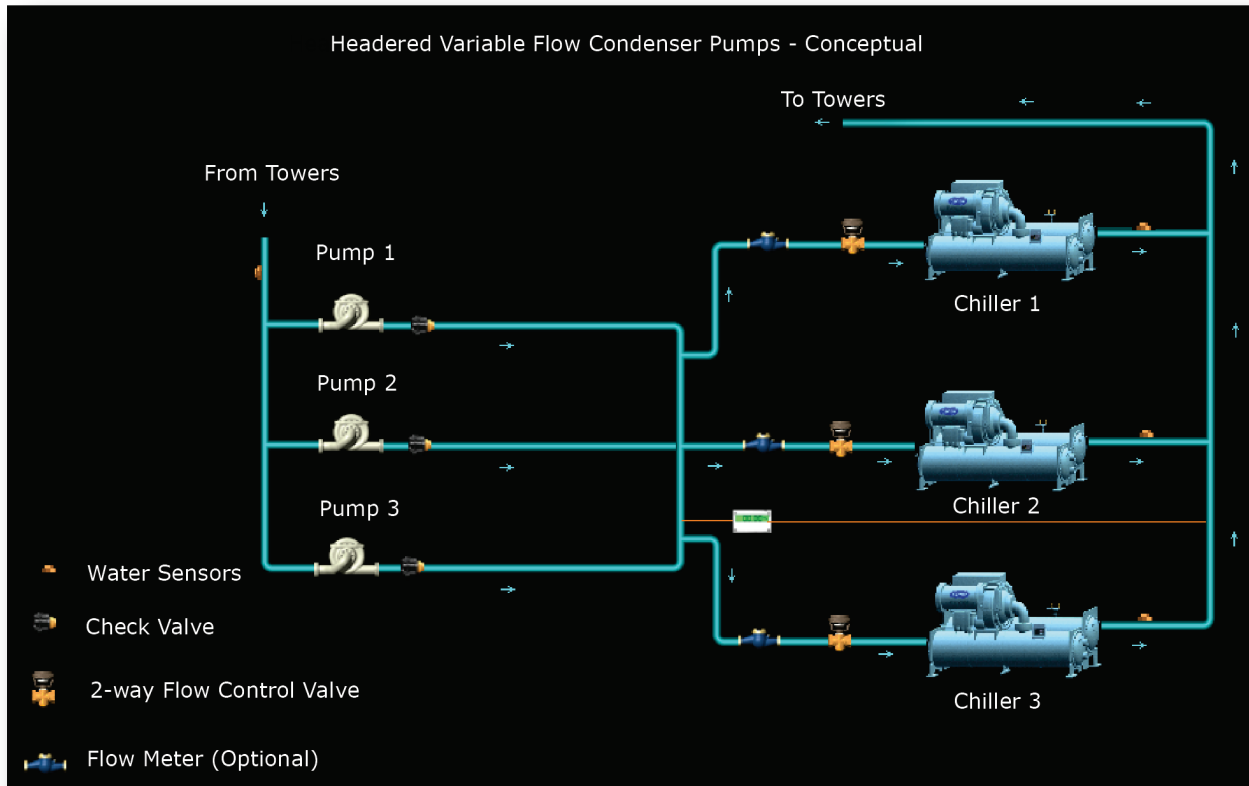

Control sequence

- 1 The associated Chiller Manager (CM) program is linked to the Condenser Pump Manager (CPM) program using a network point.
- 2 When chilled water is required, the CM signals the CPM, indicating how much condenser water flow is required.
- 3 The CPM, based on the available capacity of its condenser pumps, starts the required number of pumps to satisfy the CM's flow requirements. You can configure the run order and rotation behavior of the pumps.
- 4 Once the pumps are started, the VFD control sequence is enabled, which operates the pumps in unison to maintain the required Delta P across the entire condenser system.
- 5 The 2-way, modulating flow control valve on each condenser inlet is regulated to maintain a target design condenser Delta T for each chiller system.
- 6 If present, the optional flow meter on each branch will be used to set a minimum and maximum flow rate and override the flow control valve output.

Points and Properties

The following pages show the drop-down sections on the **Properties > Control Program** tab in the i-Vu® interface. Most of the properties are self-explanatory, however, certain key features, functions, and specific parameters are defined.

The properties are shown in the order that they appear in your i-Vu® interface. Properties that are not unique to this application, such as **Rotation and Reset**, are omitted.

The CPM program can support a maximum of 8 condenser pumps. This document shows 1 example of each properties section, since pumps 2 through 8 are the same.

Manager Status

Manager Status provides a status matrix and the option to enable or disable the pump manager.

- When **Enable Pump Manager** is **Yes**, the program controls the pumps as shown.
- When **No**, all pumps are disabled.

Manager Status							
Pumps	Position	Enable	Status	VFD Status	Maintenance Lockout	Power Loss Lockout	Failure Status
Pump 1	1	Off	Off	0.0	Off	Off	Normal
Pump 2	2	Off	Off	0.0	Off	Off	Normal
Pump 3	3	Off	Off	0.0	Off	Off	Normal
Pump 4	4	Off	Off	0.0	Off	Off	Normal
Pump 5	5	Off	Off	0.0	Off	Off	Normal
Pump 6	6	Off	Off	0.0	Off	Off	Normal
Pump 7	7	Off	Off	0.0	Off	Off	Normal
Pump 8	8	Off	Off	0.0	Off	Off	Normal

Enable Pump Manager?: ▾

Current rotation sequence number is: 1

Staging of pumps

- **Required Flow from Chiller Mgr** – the required flow value linked to the CMP from the CM
- **The maximum flow rate for EACH pump is __ gpm** – you can specify the maximum flow rate available from each pump, resulting in the sequence calculating the maximum system flow rate available, based on the number of pumps.
- **Requested number of pumps is:** – indicates the requested and actual number of running pumps
- **Lock number of pumps to run to __:** – locks the sequence to operate a specific number of pumps

▼ **Staging of Pumps**

Required Flow from Chiller Mgr (ANI2) Lock at value: Enabled?:

Required System Condenser Flow Rate is **800 gpm**.

Pump Staging:
The maximum flow rate for EACH pump is gpm.
The maximum system flow rate is **5600 gpm**. (max pump flow rate multiplied by number of pumps)

Required number of pumps is: **2**
Current number of running pumps is: **0**

Pump Staging Override:
Lock number of pumps to run to . ▼

Staging Trip Points and Delays

Displays the status and delays of the lead pump and first lag pump.

Stages 3 through 8 are listed in sequence.

▼ **Staging Trip Points and Delays**

Stage 1

Stage 1 Pump is On.

Stage 1 Pump Minimum Timers
 Min on for stage 1: : (mm:ss) current state: True
 Min off for stage 1: : (mm:ss) waiting to change: False

Stage 2

Stage 2 Pump is On.

Enable Stage 2 pump when required system flow > 700 gpm.

Stage 2 Pump Minimum Timers
 Min on for stage 2: : (mm:ss) current state: True
 Min off for stage 2: : (mm:ss) waiting to change: False

Pump VFD Control - Differential Pressure Control Loop

The pump VFDs are controlled in unison to maintain the differential pressure setpoint you enter. The Delta P is measured across the system headers.

VFD control parameters:

- **Diff Pressure** – setpoint
- **VFD Minimum Output** – speed
- **Control Output Override** – override values
- **High Differential Pressure Protection** – setpoints and actions
- **Alarms** – settings for the VFD control

▼ Pump VFD Control - Differential Pressure Control Loop

Diff Pressure (BAL) psi Lock at value: Expander: Type: Number:

Differential Pressure:
Differential Pressure is **12.10 psi**.

Setpoint:
Current Controlling Setpoint is **12.0 psi**.

DP Setpoint:
Setpoint is psi.

Differential Pressure PID (reverse acting): (BPID) Setpoint: Go: Input:

VFD Minimum Output:
VFD minimum speed output is %.

Control Output Override:
Enable Output Override Lock:
Enable Output Override value to %. Lock:

VFD Pump Speed Output:
Current speed output is **20.00 %**.

High Differential Pressure Protection:
If differential pressure increases from (normal psi - kPa if metric) to (max.psi - kPa)
decrease pump speed from (normal %) to (min. %).

Alarms

Alarm(s):
Enable Differential Pressure alarms after the equipment has been running for : mm:ss.

PRESS HI (BALM) Normal
Send High Differential Pressure Alarm if pressure > setpoint by %, hyst , for : mm:ss.

PRESS LO (BALM) Normal
Send Low Differential Pressure Alarm if pressure < setpoint by %, hyst , for : mm:ss.

Individual Pump Control - Configuration

These properties display each pump's operational status data with values you can configure.

Pump Maintenance Mode —

- **Normal** - pump remains under the control of the CPM program
- **Maintenance** - pump is no longer under the control of the CPM program
- **Re-enable** - re-starts operation

Convert the PID values in the range — sets the scaling of the VFD output to match the prevailing frequency (50Hz or 60Hz)

▼ **Individual Pump Control - Configuration**

▼ **Pump 1 Control**

Pump 1 Status: Pump 1 is currently Off.

Pump 1 Maintenance Mode: **Normal** ▼

Re-enable Pump 1 on Failure now: **Off** ▼

Re-enable Pump 1 on return of status? **No** ▼

Pump 1 Failure Lockout is: **True**.

Alarm(s):

Pump Status Alarms: Feedback Delay: Debounce Time:

P1_FAIL (BALM) Alarm

P1_HAND (BALM) Off

P1_RNTM (BALM) Off

Send runtime message if runtime exceeds hours.

▼ **Pump 1 VFD Control**

Pump 1 Effective VFD Speed: 0.0 %

Convert PID values in the range % to hz.

Pump 1 Effective VFD Frequency: 0.0 Hz

Alarm(s):

P1_FLT (BALM) Normal

Common CW Entering Temperature

The key parameter in this section is the maximum entering condenser water temperature, which is used to override the Flow Control Valve Output to 100%.

The maximum Flow Control Valve Output is overridden to 100% when the entering condenser water sensor exceeds the high temperature limit the you specify.

Common CW Entering Temperature

CW Entering Temp (BAI) 0.0 °F Lock at value: 0.0 Expander: 00 Type: Thermistor Number: 00

Max Valve Position Limit Override due to High CW Entering Temp:

Override Maximum Flow Valve Position Limit if CW Entering Temperature is > 80 deg, hyst 5
(Allows valve to open 100%)
Override status is Inactive.

Alarm(s):

Enable Condenser Water Entering Temperature alarms after the system has been running for 5:00 mm:ss.

CWENT_HI (BALM) Normal
Send High Condenser Water Entering Temp Alarm if temperature > 86 deg, hyst 5 for 0:10 mm:ss.

CWENT_LO (BALM) Alarm
Send Low Condenser Water Entering Temp Alarm if temperature < 65 deg, hyst 5 for 0:10 mm:ss.

Individual CW Flow Valve Control

Chiller 1 CW Flow Valve Control

The **CW Flow Valve Effective Minimum and Maximum Position Setpoints** only show if you select the optional Flow Meters at build time.

The settings and status values related to the flow control valve for each condenser are displayed. If no flow meters are installed, you can set a minimum valve position so that minimum flow is maintained during startup and low loads.

You can set the following:

- **Delta Temperature Setpoint** — The Delta T is calculated from the common condenser entering water setpoint and the individual condenser water leaving temperature.
- **CW Flow Valve Minimum Position Setpoint** — use when Flow Meters are not installed
- **CW Flow Valve Maximum Position Setpoint** — use when Flow Meters are not installed

▼ Individual CW Flow Valve Control

▼ Chiller 1 CW Flow Valve Control

CH1 CW Leaving Temp (BAI) 88.0 °F Lock at value: 88.0 Expander: 00 Type: Thermistor Number: 00

CH1 CW Leaving Temp (ANI2) 0.0 Lock at value: 0 Enabled?:

Chiller 1 CW Leaving Temp: 88 °F

CW Delta Temperature: 88.0 °F

Chiller 1 CW Delta Temperature Setpoint: 10 °F

Chiller 1 CW Delta Temp PID (direct acting): (BPID) Setpoint: 10.00 Go: Off Input: 88.00

Chiller 1 CW Flow Valve Minimum Position Setpoint: 50 %

Chiller 1 CW Flow Valve Maximum Position Setpoint: 100 %

Effective Chiller 1 CW Flow Valve Position: 0.0 %

Alarm(s):

CWLVG1 HI (BALM) Normal

Enable High Condenser Water Leaving Temperature alarm after the chiller has been enabled for 5 : 00 mm:ss.

Send High Condenser Water Return Temp Alarm if temperature > 100 deg, hyst 3 for 0 : 10 mm:ss.

Individual Chiller Flow Configuration - Chiller Flow Meter

You can select flow meters in EquipmentBuilder when making your control program. If you have not selected them, this property section is absent.

If you use flow meters, the CPM calculates minimum and maximum flow valve positions, based on the measured flow and the minimum and maximum flow setpoints you define.

The value that is assigned to the flow control valve will be:

- The larger of the calculated minimum or your defined minimum flow value
- The smaller of the calculated maximum or your defined maximum flow value

IMPORTANT

- We highly recommend that when using flow meters, you set the Maximum Valve position to 100% and the Minimum Valve Position to 10% to make sure that the condenser water flow values are used and not overridden by the configured valve position limits.

- You must set the **Minimum** and **Maximum CW Flow Setpoint** values in accordance with the chiller design specifications, to ensure that acceptable levels of flow are always maintained whenever a chiller is operating.

▼ **Individual Chiller Flow Configuration**

▼ **Chiller 1 Flow Meter**

CW Flow Chiller 1 (BAI) **450.0 gpm** Lock at value: Expander: Type: **0-20 mA** ▼ Number:

CW Flow Chiller 1 (ANI2) **0.00** Lock at value: Enabled?:

Chiller 1 CW Flow: 450 gpm

Chiller 1 Minimum CW Flow Setpoint: gpm (Minimum flow rate of chiller) (Overrides minimum valve position setpoint)

Chiller 1 Min Flow PID (reverse acting): (BPID) Setpoint: 300.00 Go: Off Input: 450.00

Chiller 1 Maximum CW Flow Setpoint: gpm (Maximum flow rate of chiller) (Overrides maximum valve position setpoint)

Chiller 1 Max Flow PID (reverse acting): (BPID) Setpoint: 1000.00 Go: Off Input: 450.00

Alarm(s):

Enable flow alarms after chiller 1 has been enabled for : mm:ss.

CWFL1 LO (BALM) Normal

Send Chiller 1 Low CW Flow Alarm if flow < setpoint by % for : mm:ss. Current alarm setpoint is 225 gpm.

Individual Pump Control - Configuration

All input and output points for the individual pumps are displayed and available as hardware or network points.

NOTE The **Chiller Enable** point provides chiller status to the CPM and should be connected to a point in the system that can provide individual **Chiller Run Status**.

Pump 1						
Hardware Points						
<u>Pump 1 Enable</u>	(BBO) Off	<input type="checkbox"/>	Lock at value: Off	Expander: 00	Type: Relay / Triac Output	Number: 00
<u>Pump 1 Status</u>	(BBI) Off	<input checked="" type="checkbox"/>	Lock at value: Off	Expander: 00	Type: Binary Input	Number: 00
<u>Pump 1 Power Loss</u>	(BBI) Off	<input type="checkbox"/>	Lock at value: Off	Expander: 00	Type: Binary Input	Number: 00
<u>P1 VFD Fault</u>	(BBI) Off	<input type="checkbox"/>	Lock at value: Off	Expander: 00	Type: Dry Contact	Number: 00
<u>Chiller 1 Enable</u>	(BBI) Off	<input checked="" type="checkbox"/>	Lock at value: Off	Expander: 00	Type: Dry Contact	Number: 00
<u>P1 VFD Output</u>	(BAO) 0.0 %	<input type="checkbox"/>	Lock at value: 0.0	Expander: 00	Type: Electrical 0-10 Volt	Number: 00
<u>CH1 CW Flow Valve Output</u>	(BAO) 0.0 %	<input type="checkbox"/>	Lock at value: 0.0	Expander: 00	Type: Electrical 0-10 Volt	Number: 00
Network Points						
<u>Pump 1 Enable</u>	(BNO) Off	<input type="checkbox"/>	Lock at value: Off	Enabled?: <input checked="" type="checkbox"/>		
<u>Pump 1 Status</u>	(BNI) Off	<input type="checkbox"/>	Lock at value: Off	Enabled?: <input checked="" type="checkbox"/>		
<u>Pump 1 Power Loss</u>	(BNI) Off	<input type="checkbox"/>	Lock at value: Off	Enabled?: <input checked="" type="checkbox"/>		
<u>P1 VFD Fault</u>	(BNI) Off	<input type="checkbox"/>	Lock at value: Off	Enabled?: <input checked="" type="checkbox"/>		
<u>Chiller 1 Enable</u>	(BNI) Off	<input type="checkbox"/>	Lock at value: Off	Enabled?: <input checked="" type="checkbox"/>		
<u>P1 VFD Output</u>	(ANO) 0.00	<input type="checkbox"/>	Lock at value: 0	Enabled?: <input checked="" type="checkbox"/>		
<u>CH1 CW Flow Valve Output</u>	(ANO) 0.0	<input type="checkbox"/>	Lock at value: 0	Enabled?: <input checked="" type="checkbox"/>		

Variable flow, dedicated condenser pumps control sequence

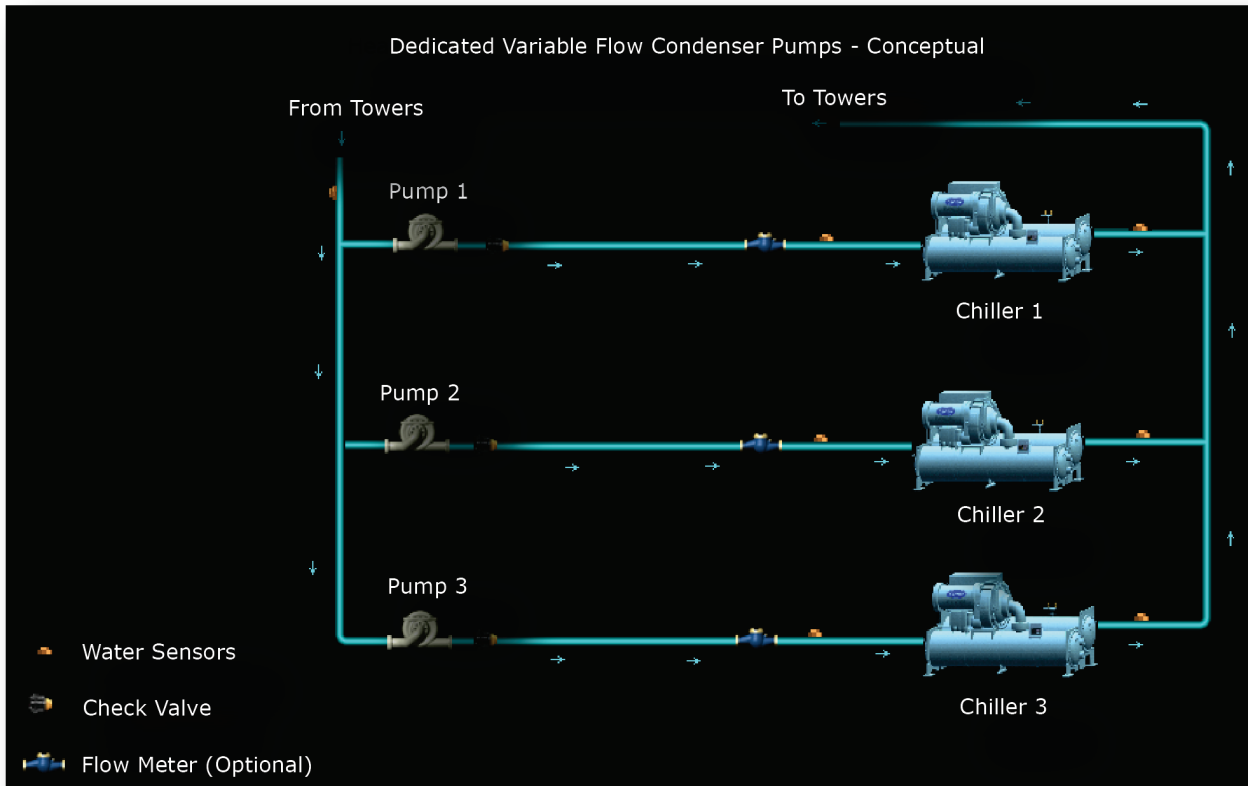

NOTES

- The variable flow, dedicated condenser pump sequence is a simplified version of the *Variable flow, headered condenser pump control sequence* (page 4).
- Run order or rotation logic is not necessary because the sequence requires dedicated pumps (each pump is directly linked to a specific chiller). Also, the associated Chiller Manager does not need to send flow requirements to the Condenser Pump Manager.
- Each pump must be equipped with a flow check valve device or a 2-position isolation valve to prevent reverse flow through pumps that are not currently operating.
- If you have specified optional flow meters, the configuration screens are shown at the end of this document.

Control Sequence

- 1 The associated Chiller Manager (CM) program is linked to the Condenser Pump Manager (CPM) program using network or hardware points.
- 2 When the CM needs to start a chiller, the logic enables the corresponding **Run Pump** point, followed by enabling the corresponding condenser pump.

- Once a pump is started, the associated VFD control sequence is enabled, which operates the pump to maintain your defined condenser Delta T.

NOTE Each chiller/pump pair operates independently.

- For systems equipped with flow meters, you can specify minimum and maximum flow settings. These values override the VFD settings selected by the temperature control logic. This ensures that minimum and maximum flow values are never exceeded.

Points and Properties

The following pages show the drop-down sections on the **Properties > Control Program** tab in the i-Vu® interface. Most of the properties are self-explanatory, however, certain key features, functions, and specific parameters are defined.

The properties are shown in the order that they appear in your i-Vu® interface. Properties that are not unique to this application, such as **Rotation and Reset**, are omitted.

The CPM program can support a maximum of 8 condenser pumps. This document shows 1 example of each properties section, since pumps 2 through 8 are the same.

Manager Status

Manager Status provides a status matrix and the option to enable or disable the pump manager.

- When **Enable Pump Manager** is **Yes**, the program controls the pumps as shown.
- When **No**, all pumps are disabled.

Manager Status							
Pumps	Position	Enable	Status	VFD Status	Maintenance Lockout	Power Loss Lockout	Failure Status
Pump 1	1	Off	Off	0.0	Off	Off	Normal
Pump 2	2	Off	Off	0.0	Off	Off	Normal
Pump 3	3	Off	Off	0.0	Off	Off	Normal
Pump 4	4	Off	Off	0.0	Off	Off	Normal
Pump 5	5	Off	Off	0.0	Off	Off	Normal
Pump 6	6	Off	Off	0.0	Off	Off	Normal
Pump 7	7	Off	Off	0.0	Off	Off	Normal
Pump 8	8	Off	Off	0.0	Off	Off	Normal

Enable Pump Manager?:

Current rotation sequence number is: 1

Common CW Entering Temperature

The key parameter in this section is the maximum entering condenser water temperature, which is used to override the VFD Output to 100%.

The maximum VFD Output is overridden to 100% when the entering condenser water sensor exceeds the high temperature limit that you specify.

Common CW Entering Temperature

CW Entering Temp (BAI) 82.0 °F Lock at value: 82.0 Expander: 00 Type: Thermistor Number: 00

Max VFD Limit Override due to High CW Entering Temp::
Override Maximum VFD Output Limit if CW Entering Temperature is > 80 deg, hyst 5. (Allows pumps to run at 100% speed)
Override status is Active.

Alarm(s):
Enable Condenser Water Entering Temperature alarms after the system has been running for 5:00 mm:ss.

CWENT_HI (BALM) Normal
Send High Condenser Water Entering Temp Alarm if temperature > 86 deg, hyst 5 for 0:10 mm:ss.

CWENT_LO (BALM) Normal
Send Low Condenser Water Entering Temp Alarm if temperature < 65 deg, hyst 5 for 0:10 mm:ss.

Individual Pump Control - Configuration - Pump Control

These properties display each system pump's operational status data and values you can configure.

Pump Maintenance Mode

- **Normal** - pump remains under the control of the CPM program
- **Maintenance** - pump is no longer under the control of the CPM program
- **Re-enable** - re-starts operation after failure

▼ Individual Pump Control - Configuration

▼ Pump 1 Control

Pump Start Delay: Enable pump : mm:ss after equipment is commanded On.

Shutdown Delay: Prior to disabling pump, hold output signal for : mm:ss.

Pump 1 Delay on power loss restore is : (mm:ss) with output of **False** for 0:00 (mm:ss).

Pump 1 Enable: Pump 1 is currently **Disabled**.

Pump 1 Maintenance Mode: **Normal** ▼

Re-enable Pump 1 on Failure now: **Off** ▼

Re-enable Pump 1 on return of status? **No** ▼

Pump 1 Failure Lockout is: **False**.

Alarm(s):

Pump Status Alarms: Feedback Delay: Debounce Time:

P1_FAIL (BALM) **Normal**

P1_HAND (BALM) **Off**

P1_RNTM (BALM) **Off**

Send runtime message if runtime exceeds hours.

Individual Pump Control - Configuration - Pump VFD Control

In the **Pump VFD Control** parameters, you can configure settings that relate to the VFD control sequence, including Delta T setpoint, and minimum and maximum output values. You must set the minimum and maximum output values in accordance with the chiller design specifications to ensure that acceptable levels of flow are always maintained whenever a chiller is operating.

Set the scaling of the VFD output to match the prevailing frequency (50Hz or 60Hz).

The settings are available in this properties section when flow meters were not selected in EquipmentBuilder.

▼ Pump 1 VFD Control

CH1 CW Leaving Temp (BAI) 87.0 °F Lock at value: 0.0 Expander: 00 Type: **Thermistor** Number: 00

CH1 CW Leaving Temp (ANI2) 0.0 Lock at value: 0 Enabled?:

Chiller 1 CW Leaving Temp: 87 °F

CW Delta Temperature: 5.0 °F

Pump 1 CW Delta Temperature Setpoint: 10 °F

Pump 1 CW Delta Temp PID (direct acting): (BPID) Setpoint: 10.00 Go: Off Input: 5.00

Pump 1 Minimum VFD Speed Setpoint: 50 %

Pump 1 Maximum VFD Speed Setpoint: 100 %

Pump 1 Effective VFD Speed: 0.0 %

Convert PID values in the range [0, 100] % to [0, 60] hz.

Pump 1 Effective VFD Frequency: 0.0 Hz

Alarm(s):

P1 FLT (BALM) Normal

Enable Alarm 0 : 01 mm:ss after input is On.

CWLVG1 HI (BALM) Normal

Enable High Condenser Water Leaving Temperature alarm after the pump has been running for 5 : 00 mm:ss.

Send High Condenser Water Return Temp Alarm if temperature > 100 deg, hyst 3 for 0 : 10 mm:ss.

Individual Pump Command Points - Configuration

All input and output points for the individual pumps are displayed and available as hardware or network points.

NOTE The **Run Pump** point provides a pump start to the CPM and should be connected to a point in the system that signals the start of the corresponding condenser pump. On chillers with local pump control, a hardware or network point typically starts the condenser pump.

Pump 1						
Hardware Points						
<u>Pump 1 Enable</u>	(BBO) Off	<input type="checkbox"/> Lock at value:	Off	Expander:	00	Type: Relay / Triac Output Number: 00
<u>Pump 1 Status</u>	(BBI) Off	<input type="checkbox"/> Lock at value:	Off	Expander:	00	Type: Binary Input Number: 00
<u>Pump 1 Power Loss</u>	(BBI) Off	<input type="checkbox"/> Lock at value:	Off	Expander:	00	Type: Binary Input Number: 00
<u>Run Pump 1</u>	(BBI) Off	<input type="checkbox"/> Lock at value:	Off	Expander:	00	Type: Dry Contact Number: 00
<u>P1 VFD Fault</u>	(BBI) Off	<input type="checkbox"/> Lock at value:	Off	Expander:	00	Type: Dry Contact Number: 00
<u>P1 VFD Output</u>	(BAO) 0.0 %	<input type="checkbox"/> Lock at value:	0.0	Expander:	00	Type: Electrical 0-10 Volt Number: 00
Network Points						
<u>Pump 1 Enable</u>	(BNO) Off	<input type="checkbox"/> Lock at value:	Off	Enabled?:	<input checked="" type="checkbox"/>	
<u>Pump 1 Status</u>	(BNI) Off	<input type="checkbox"/> Lock at value:	Off	Enabled?:	<input checked="" type="checkbox"/>	
<u>Pump 1 Power Loss</u>	(BNI) Off	<input type="checkbox"/> Lock at value:	Off	Enabled?:	<input checked="" type="checkbox"/>	
<u>Run Pump 1</u>	(BNI) Off	<input type="checkbox"/> Lock at value:	Off	Enabled?:	<input checked="" type="checkbox"/>	
<u>P1 VFD Fault</u>	(BNI) Off	<input type="checkbox"/> Lock at value:	Off	Enabled?:	<input checked="" type="checkbox"/>	
<u>P1 VFD Output</u>	(ANO) 0.00	<input type="checkbox"/> Lock at value:	0	Enabled?:	<input checked="" type="checkbox"/>	

Optional Flow Meter Properties

When optional flow meters are specified, the **Pump VFD Control** section replaces the previous page, and a new Properties section for the actual flow meter is added to the program. This includes information relating to the flow meter min/max flow override sequence.

IMPORTANT

- We highly recommend that when using flow meters, you set the Maximum VFD Speed Setpoint to 100% and the Minimum VFD Speed Setpoint to 10% to make sure that the condenser water flow values are used and not overridden by the configured valve position limits.
- You must set the Minimum and Maximum CW Flow Setpoint values in accordance with the chiller design specifications, to ensure that acceptable levels of flow are always maintained whenever a chiller is operating.

▼ Pump 1 VFD Control

CH1 CW Leaving Temp (BAI) °F Lock at value: Expander: Type: **Thermistor** Number:

CH1 CW Leaving Temp (ANI2) 0.0 Lock at value: Enabled?:

Chiller 1 CW Leaving Temp: 90 °F

CW Delta Temperature: 8.0 °F

Pump 1 CW Delta Temperature Setpoint: °F

Pump 1 CW Delta Temp PID (direct acting): (BPID) Setpoint: 10.00 Go: On Input: 8.00

Pump 1 Minimum VFD Speed Setpoint: %

Pump 1 Maximum VFD Speed Setpoint: %

Min VFD CW Flow Limit Override: Active

Pump 1 Effective Minimum VFD Speed Setpoint: 100.0 %

Pump 1 Effective Maximum VFD Speed Setpoint: 100.0 %

Pump 1 Effective VFD Speed: 85.0 %

Convert PID values in the range [] % to [] hz.

Pump 1 Effective VFD Frequency: 51.0 Hz

▼ Pump 1 Flow Meter

CW Flow Pump 1 (BAI) 0.0 gpm Lock at value: Expander: Type: **0-20 mA** Number:

CW Flow Pump 1 (ANI2) 0.00 Lock at value: Enabled?:

Pump 1 CW Flow: 0 gpm

Pump 1 Minimum CW Flow Setpoint: gpm (Minimum flow rate of chiller) (Overrides minimum VFD speed setpoint)

Pump 1 Min Flow PID (reverse acting): (BPID) Setpoint: 300.00 Go: On Input: 0.00

Pump 1 Maximum CW Flow Setpoint: gpm (Maximum flow rate of chiller) (Overrides maximum VFD speed setpoint)

Pump 1 Max Flow PID (reverse acting): (BPID) Setpoint: 1000.00 Go: On Input: 0.00

Compliance

FCC Compliance

This equipment has been tested and found to comply with the limits for a Class A digital device, pursuant to Part 15 of the FCC Rules. These limits are designed to provide reasonable protection against harmful interference when the equipment is operated in a commercial environment. This equipment generates, uses, and can radiate radio frequency energy and, if not installed and used in accordance with the instruction manual, may cause harmful interference to radio communications. Operation of this equipment in a residential area is likely to cause harmful interference in which case the user will be required to correct the interference at his own expense.



CAUTION Changes or modifications not expressly approved by the responsible party for compliance could void the user's authority to operate the equipment.

CE Compliance



WARNING This is a Class A product. In a domestic environment, this product may cause radio interference in which case the user may be required to take adequate measures.

Document revision history

Important changes to this document are listed below. Minor changes such as typographical or formatting errors are not listed.

Date	Topic	Change description	Code*
10/5/16	Common CW Entering Temperature - Headered	Clarified explanation.	X-AE-BL-E
	Common CW Entering Temperature - Dedicated	Screen capture corrected and text changed to reflect that dedicated pumps do not have a flow control valve.	X-AE-BL-E

* For internal use only



CARRIER CORPORATION ©2016

A member of the United Technologies Corporation family · Stock symbol UTX · Catalog No. 11-808-577-01 · 10/5/2016