

#20907 – 6/14/18

Overview

The Immersion Temperature Sensor is made for thermowell mounting and temperature measurement in water pipes, water tanks or cooling tower sump applications. The rigid probe is made of Stainless Steel and made in different lengths for a custom thermowell fit. Enclosure mounting styles come in plastic or metal for both NEMA 1 and NEMA 4 applications and are all plenum rated.

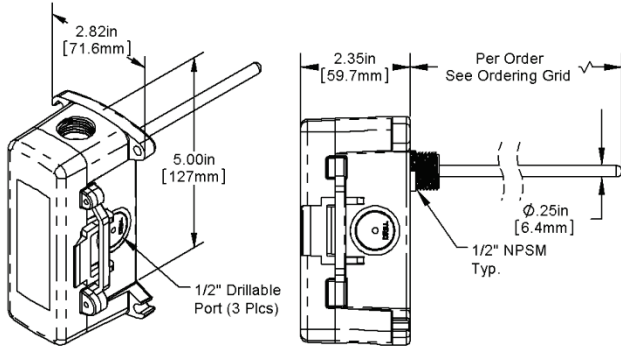

Figure 1: BB2 Box Immersion
Part #s NSB-10K-2-I-2-BB2 (2" probe, no thermowell)
NSB-10K-2-I-4-BB2 (4" probe, no thermowell)
NSB-10K-2-I-2-M304 (2" probe, 304 SS thermowell)
NSB-10K-2-I-4-M304 (4" probe, 304 SS thermowell)

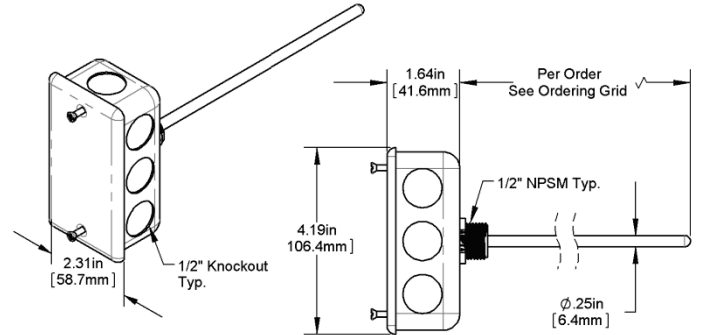

Figure 3: J-Box Immersion (Standard)
Part #s NSB-10K-2-I-2 (2" probe, no thermowell)
NSB-10K-2-I-4 (4" probe, no thermowell)
NSB-10K-2-I-2-M304 (2" probe, 304 SS thermowell)
NSB-10K-2-I-4-M304 (4" probe, 304 SS thermowell)

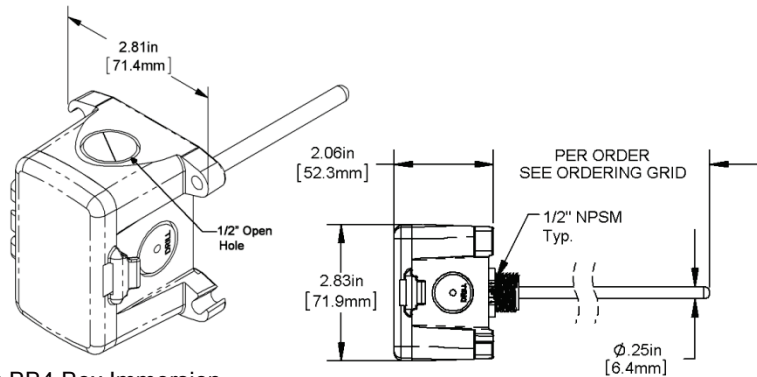

Figure 2: BB4 Box Immersion
Part #s NSB-10K-2-I-2-BB4 (2" probe, no thermowell)
NSB-10K-2-I-4-BB4 (4" probe, no thermowell)
A Pierceable Knockout Plug (Part # NSB-PKP-100) is available for the open port in the BB4

Thermowells

Thermowells are hollow tubes closed off on one end and threaded at the other end. They are permanently placed into pipes, tanks, or sumps so that the probes on immersion temperature sensors can be inserted into the pipe. The temperature of the pipe's contents is transferred through the wall of the thermowell. The thermowell prevents the pipe's contents from escaping and maintains the pressure of pressurized pipes.

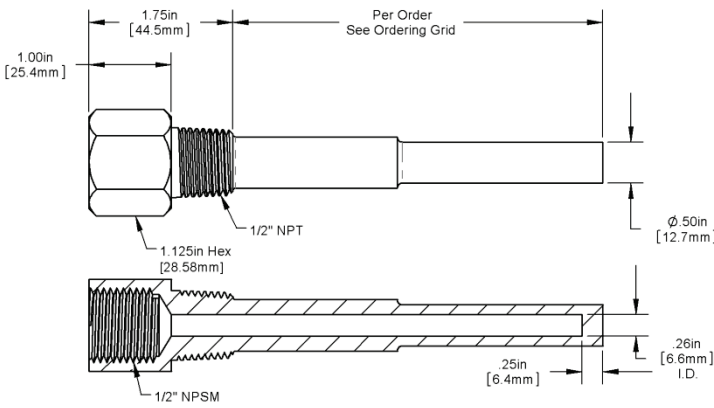

Figure 4: Machined Bar Stock ThermoWell

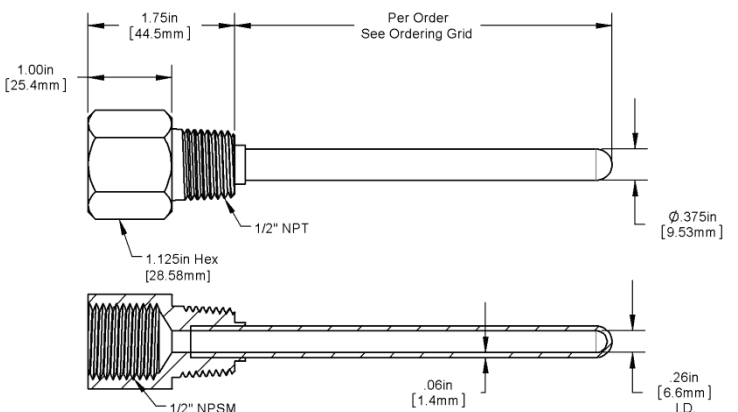

Figure 5: Two-Part Welded Thermowell

Specifications subject to change without notice.

#20907 – 6/14/18

Thermowells (continued...)

Choosing the correct Thermowell

As part of our ZS Sensor line, Carrier sells 2.5" and 4.5" machined thermowells made of Brass or 304 Stainless Steel (SS) and two-part welded thermowells made of 304 Stainless Steel. The two-part welded thermowells are not as strong as their machined counterparts. Carrier recommends the use of welded thermowells be limited to small diameter systems in low vibration environments. Carrier strongly encourages that single-piece machined thermowells be used when possible. See the entries for Welded SS in the following design tables. Additionally, welded stainless steel thermowells should not be used in turbulent flow; ideally they should be three to five pipe diameters from elbows or transitions.

Thermowell Material	Temperature in Degrees Fahrenheit						
	70°F	200°F	400°F	600°F	800°F	1000°F	1200°F
	Pressure Rating (Pounds per Square Inch)						
Brass	5000	4200	1000	-	-	-	-
Welded 304 SS	982	820	675	604	550	510	299
304 SS	7000	6200	5600	5400	5200	4500	1650

Thermowell Material	Fluid Type	Insertion Length (inches)		
		1-2"	1-4"	1-8"
		Maximum Fluid Velocity (Feet per second)		
Brass	Air/Steam	207	75.5	27.3
	Water	59.3	32.2	19.7
Welded 304 SS	Air/Steam	169	61	20
	Water	88	20	10
304 SS	Air/Steam	300	109	39.5
	Water	148	82.2	-

The values shown in Table 3 are based on operating temperatures of 350°F for brass and 1000°F for stainless steel. Slightly higher velocities are possible at lower temperatures.

Comparing the Wake Frequency and the Resonant Frequency

Table 2 and Table 3 were developed to insure that there will be no thermowell failures due to application stresses. Thermowell failures, in most cases, are not due to the effects of pressure or temperature on the well. The calculations necessary to provide adequate strength, under given conditions, are familiar enough to permit proper choice of wall thickness and material. The values shown in Table 2 are conservative, and intended primarily as a guide.

Less familiar, and more dangerous, are the **vibration effects** to which thermowells are subjected. Fluid, flowing by the well, forms a turbulent wake (called the Von Karman Trail) which has a definite frequency, based on the diameter of the thermowell and the velocity of the fluid. It is important that the thermowell have sufficient stiffness so that the wake frequency will never equal the resonant (natural) frequency of the thermowell itself.

If the resonant frequency of the thermowell coincided with the wake frequency, the thermowell would vibrate to destruction and break off in the piping. Thermowells are also safe if the resonant frequency **below** the wake frequency or if the fluid velocity is constantly fluctuating through the critical velocity point. Nevertheless, if the installation is not hampered by the use of a sufficiently stiff thermowell, Carrier recommends the values given in Table 3 not be exceeded.

Specifications subject to change without notice.

Thermowells (continued...)

Table 3: Pipe Insertion Recommendations using Carrier Thermowells

Pipe Size	Schd 40 Wall Thickness	Schd 80 Wall Thickness	Recommended Thermowell Type	Shank Length	Actual Insertion Schd 40	Actual Insertion Schd 80
1/2	0.109	0.147	2"	2.5	2" @ elbow	2" @ elbow
3/4	0.113	0.154	2"	2.5	2" @ elbow	2" @ elbow
1.00	0.133	0.179	2"	2.5	2" @ elbow	2" @ elbow
1 ½	0.145	0.2	2"	2.5	2" @ elbow	2" @ elbow
2.00	0.154	0.218	2"	2.5	2" @ elbow	2" @ elbow
2 ½	0.203	0.276	2"	2.5	2" @ elbow	2" @ elbow
3.00	0.216	0.3	2"	2.5	2.28	2.20
4.00	0.237	0.337	2"	2.5	2.26	2.16
5.00	0.258	0.375	2"	2.5	2.24	2.13
6.00	0.28	0.432	4"	4.5	4.22	4.07
8.00	0.322	0.5	4"	4.5	4.18	4.00
10.00	0.365	0.593	4"	4.5	4.14	3.91

Specifications

Sensor:	Passive, 2 wire	Mounting	½" NPSM Plastic Threads
Thermistor	Thermal resistor (NTC)	Enclosure Types	
Temp. Output	Resistance per order, 10k Type 2	J-Box (-JB)	With eight ½" knockouts
Accuracy	(std) ±0.36°F, (±0.2°C)	BB2 Box	With three ½" NPSM & three ½" drill-outs
Stability	0.036°F/Year, (<0.02°C/Year)	BB4 Box	With three ½" drill-outs & one ½" open port
Heat dissipation	2.7 mW/°C	Enclosure Ratings	
Temp. Drift	<0.02°C per year	J-Box (-JB)	NEMA 1
Probe range	-40° to 221°F (-40° to 105°C)	BB2 Box	NEMA 4X,
Sensitivity	Approximate @ 32°F (0°C)	IP66 BB4 Box	IP10
Thermistor	Non-linear		(IP44 with Knockout Plug in the open port)
Lead wire	22 AWG stranded	Enclosure Materials	
Insulation	Etched Teflon, Plenum rated	J-Box (-JB)	Galvanized steel, UL94H-B
Probe	Rigid, 304 Stainless Steel, 0.25" OD	BB2 Box	Polycarbonate, UL94V-0, UV rated
Probe Length	2" or 4"	BB4 Box	Polycarbonate & Nylon, UL94V-0
		Ambient (Encl.)	0 to 100% RH, Non-condensing
		BB2 & BB4 Boxes	-40°F to 185°F, (-40° to 85°C)
		J-Box & No Box	-40°F to 212°F, (-40° to 100°C)
		Agency	RoHS, *CE
			JIS C1604-1989
			*Thermistors are CE compliant

Specifications subject to change without notice.

Thermowell Installation

To install a thermowell, a pipe fitter typically drills a 3/4-inch hole into the pipe where the thermowell is needed. A customer-provided fitting, called a Threadolet or Weldolet, is welded to the pipe over the hole. The Threadolet has a 1/2" NPT thread in the center. Thread sealant such as Teflon tape or pipe dope is applied to the 1/2" NPT threads of the thermowell. The thermowell is then inserted into the Threadolet and tightened.

Figure 6 shows a 4" thermowell and 4" immersion sensor probe installed in a 12" pipe. In a properly insulated pipe with liquid or steam, the temperature is essentially the same across the entire cross-section of the pipe. Usually thermowells are sized to extend to the center of the pipe; however, shorter thermowells will give proper temperature readings if properly installed. The shorter thermowells are used in pipes with high flow velocities.

Since the wall thickness of the pipe commonly used for HVAC plumbing is 1/2-inch, the thermowell sticks four inches into the pipe. The four-inch distance is from the inside surface of the pipe to the end of the thermowell.

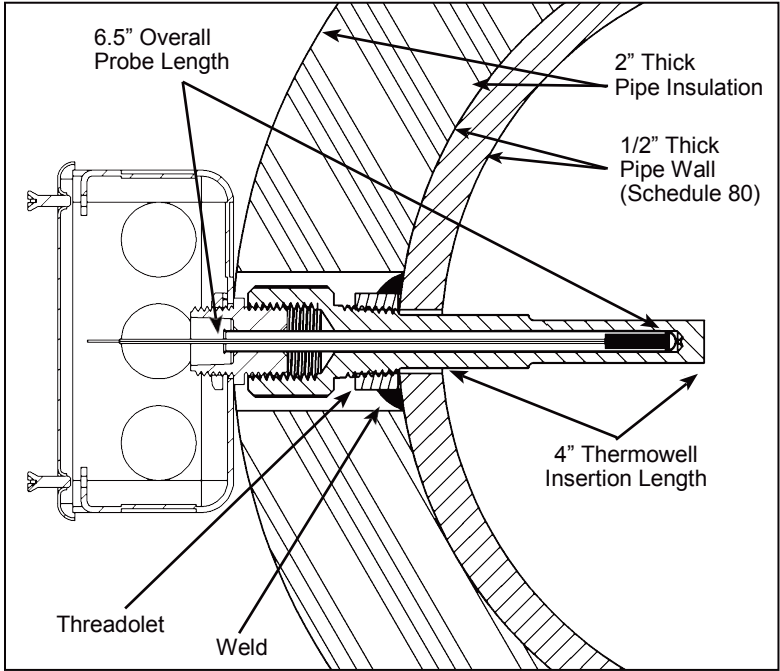

Figure 6: Typical Immersion Probe Installed in a Thermowell

Pipes less than 3 inches in diameter

T-Mount

Figure 7 shows how a 2" tee and a 1/2" to 2" bushing allows a 2" thermowell to measure the temperature of the contents of a 2" water pipe.

Be sure to use a thread sealant on the outside threads of the thermowell.

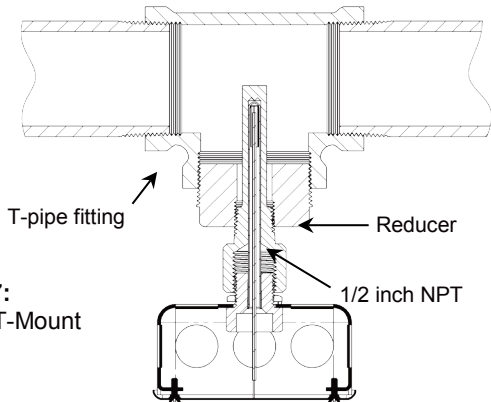

Figure 7: Typical T-Mount

Corner Mount

Figure 8 shows how a pipe tee can be used in an elbow application. A 2" tee and a 1/2" to 2" bushing allows a 4" thermowell to measure the temperature of the contents of a 2" water pipe.

NOTE Temperatures in pipes as small as 1-1/4" may be measured by this method. In small pipes, the diameter of the thermowell may become a significant obstruction, so be sure to check for proper flow rates after installation is complete.

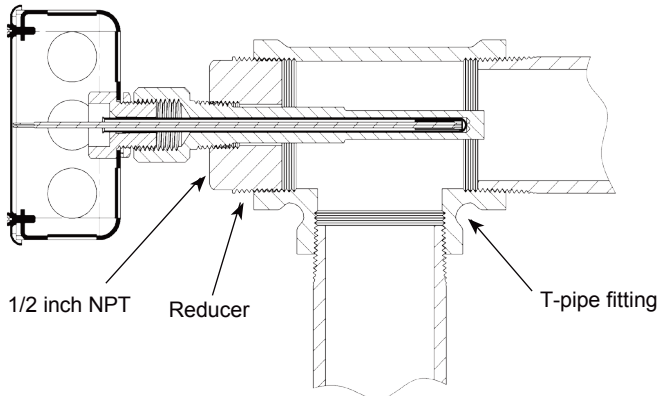

Figure 8: Typical Corner Mount

#20907 – 6/14/18

Immersion Sensor Installation

Immersion probes come with a plastic fitting that screws into the threads of the thermowell.

Pull the immersion probe away from the plastic fitting until the probe is fully extended. Insert the probe into the thermowell until the plastic fittings come into contact with the threads in the thermowell. Hand tighten the immersion sensor snugly into the thermowell without too much torque. The temperature probe slides back into the enclosure as the sensor contacts the end of the thermowell.

Make sure that the tip of the immersion sensor probe is in good contact with the bottom of the thermowell by pushing on the flaired end of the probe until the tip bottoms out in the thermowell.

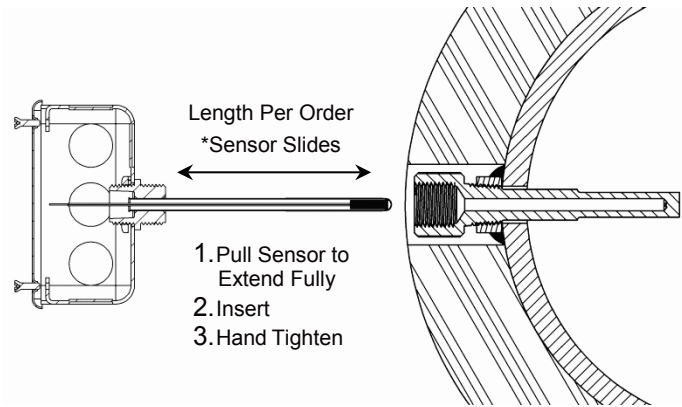

Figure 9: Immersion Sensor Before Insertion

* As the immersion sensor is hand-threaded into the thermowell, the flair end of the probe will be pushed into the enclosure as the probe tip bottoms out in the thermowell. The probe can slide up to 1.6". The Junction Box enclosure is shown above but the process is the same for the other enclosure styles.

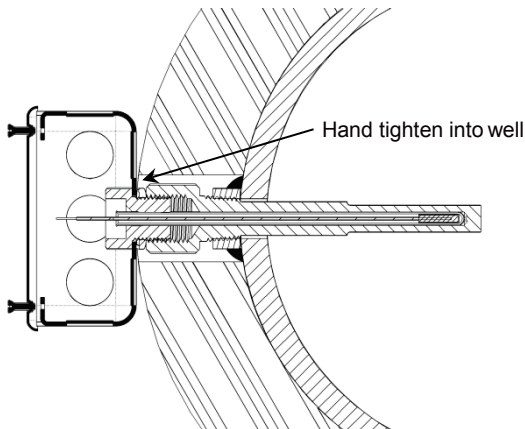

Figure 10: Typical Sensor Inserted

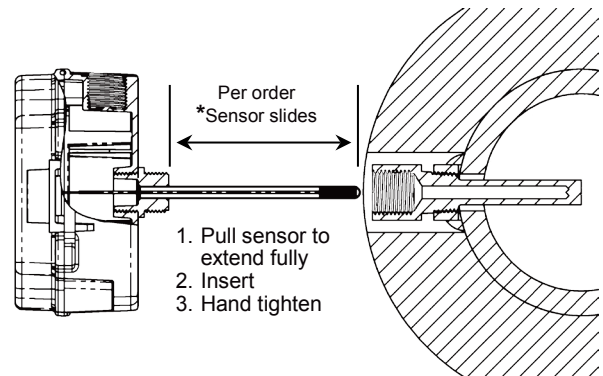

Figure 11: BB4 Sensor Before Insertion

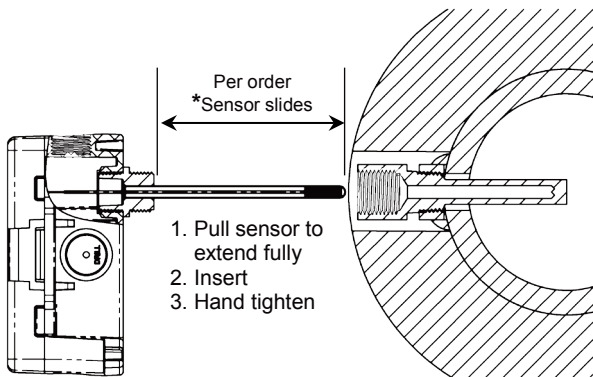

Figure 12: BB2 Sensor Before Insertion

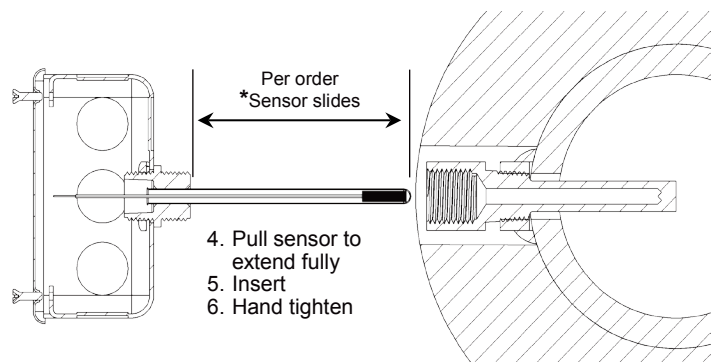

Figure 13: Standard J-Box Before Insertion

*As the box is hand screwed, the probe will push into the box as the probe tip bottoms out in the well. The probe can slide up to 1.6 inches.

Specifications subject to change without notice.

#20907 – 6/14/18

Wiring and Termination

Carrier recommends using twisted pair of at least 22AWG for all wire connections. Larger gauge wire may be required for long runs. All wiring must comply with the National Electric Code (NEC) and local codes. Do NOT run this device's wiring in the same conduit as high or low voltage AC power wiring. Tests show that inaccurate signal levels are possible when AC power wiring is present in the same conduit as the sensor wires.

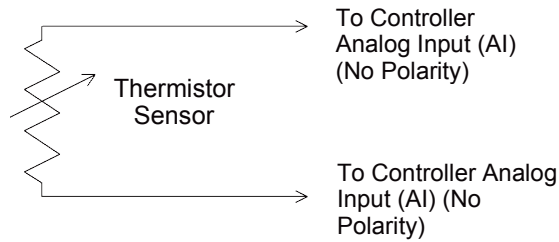

Figure 14: 2 Wire Lead Wire Termination for Thermistor

Diagnostics

Problems:

Controller reports higher or lower than actual temperature.

Possible Solutions:

- Confirm the input is set up correctly in the front end software
- Check wiring for proper termination and continuity (shorted or open).
- Disconnect wires and measure sensor resistance and verify the "Sensor" output is correct.