

#20911 – 2/15/18

Overview

Clamp-on Sensors are made for direct pipe mounting and temperature measurement of water pipe applications. These sensors are for mounting before any insulation is on the pipe.

Strap Sensors are spring-loaded units that are for mounting to pipes with up to 2" of insulation using a unique spring sensor extension.

Enclosure mounting styles come in plastic or metal for both NEMA 1 and NEMA 4 applications and are all plenum rated.

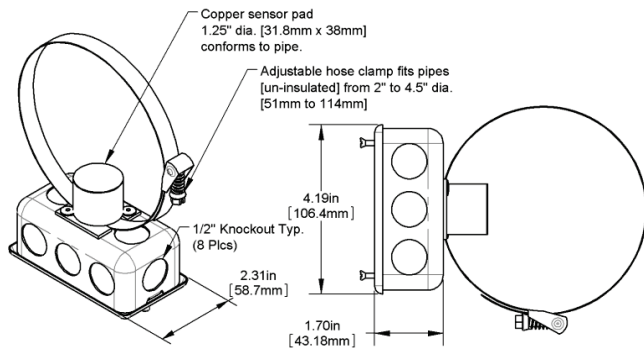

**Figure 1: Clamp-On with NEMA 1 J-Box (JB)
Part # NSB-10K-2-S**

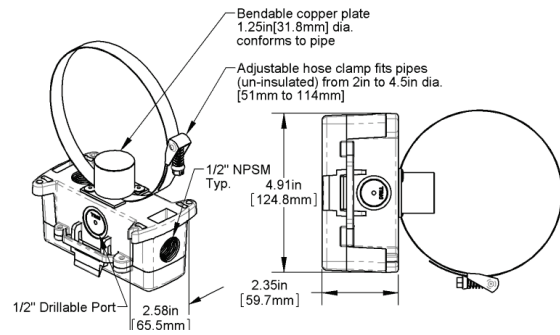

**Figure 2: Clamp-On with w/ NEMA 4 BB2 Box
Part # NSB-10K-2-S-BB2**

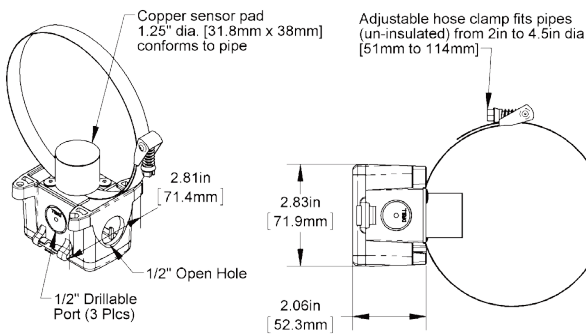
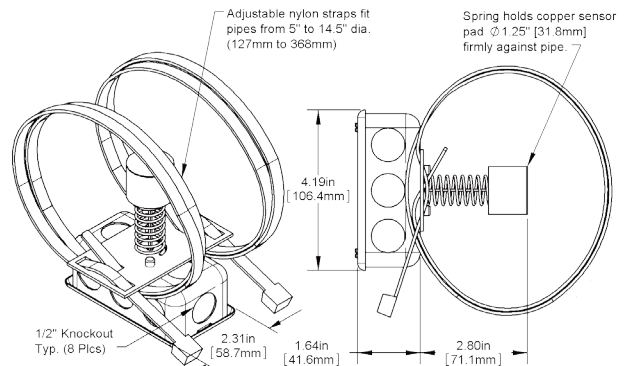
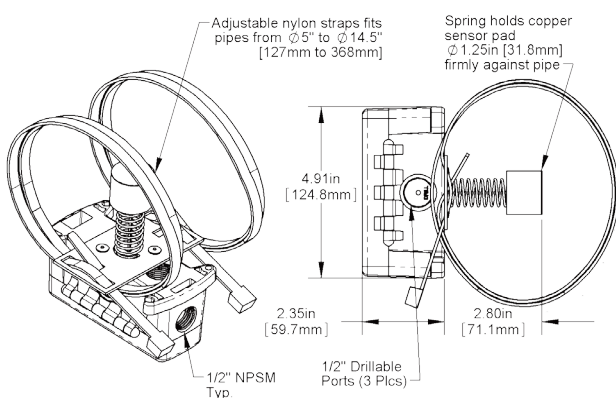

Figure 3: Clamp-On with NEMA 1 BB4 Box-Part # NSB-10K-2-S-BB4
A Pierceable Knockout Plug (Part # NSB-PKP-100) is available for the open port in the BB4.



**Figure 4: Spring-Loaded Strap w/ NEMA 1 J-Box (JB)
Part # NSB-10K-2-STP**



**Figure 5: Spring-Loaded Strap w/ NEMA 4 BB2 Box
Part # NSB-10K-2-STP-BB2**

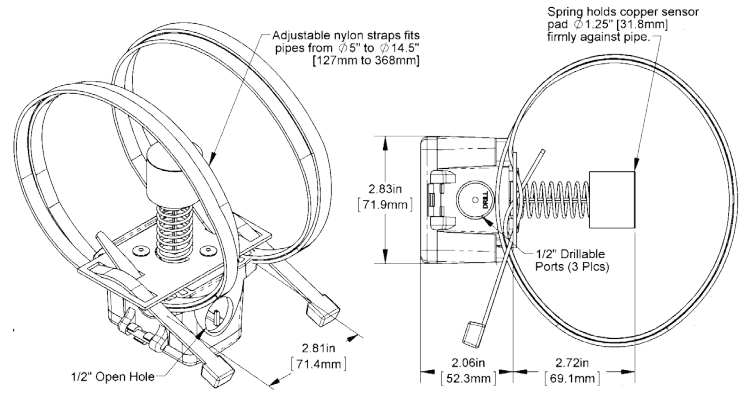

**Figure 6: Spring-Loaded Strap w/ NEMA 1 BB4 Box
Part # NSB-10K-2-STP-BB4**
A Pierceable Knockout Plug (Part # NSB-PKP-100) is available for the open port in the BB4.

Specifications

Sensor	Passive, NTC, 2 wire	Enclosure Types	
Thermistor	Thermal resistor	J-Box (-JB)	With eight 1/2" knock-outs
Temp. Output	Resistance, 10k Type 2	BB2 Box	With three 1/2" NPSM and three 1/2" drill-outs
Accuracy (Std)	±0.36°F, (±0.2°C)	BB4 Box:	With three 1/2" drill-outs and one 1/2" open port
Stability	< 0.036°F/Year, (<0.02°C/Year)		
Heat dissipation	2.7 mW/°C	Enclosure Ratings	
Temp. Drift	<0.02°C per year	J-Box (-JB)	NEMA 1
Probe range	-40° to 221°F (-40° to 105°C)	BB2 Box	NEMA 4, IP66, UV Rated
Lead wire	22awg stranded	BB4 Box	IP10 (with spring installed) (IP44 without spring and with Knockout Plug installed in the open port)
Wire Insulation	Etched Teflon, Plenum rated		
Probe	Copper sensor plate, 24 AWG, 1.25" diameter	Enclosure Material	
Mounting		J-Box (-JB)	Galvanized steel, UL94H-B
Clamp-On (-S)	1/2" Stainless steel worm gear hose clamp	BB2 Box	Polycarbonate, UL94V-0, UV rated
Strap (-STP)	48" Nylon tie strap, 1/2" wide	BB4 Box	Polycarbonate and Nylon, UL94V-0
		Ambient (Enclosure)	0 to 100% RH, Non-condensing
		J-Box (-JB)	-40°F to 212°F, (-40° to 100°C)
		BB2 Box	-40°F to 185°F, (-40 to 85°C)
		BB4 Box	-40°F to 185°F, (-40 to 85°C)
		Agency	RoHS, CE

Mounting

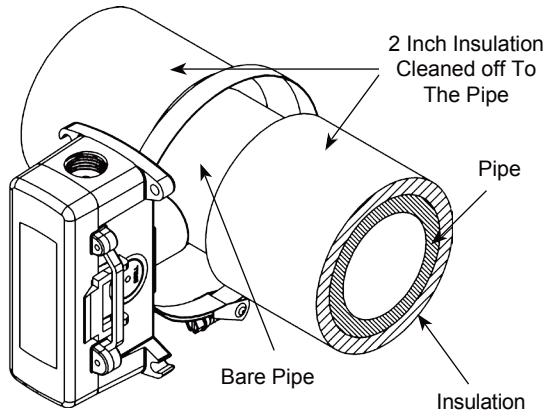

Figure 7: Typical Clamp-On (-S) Installation

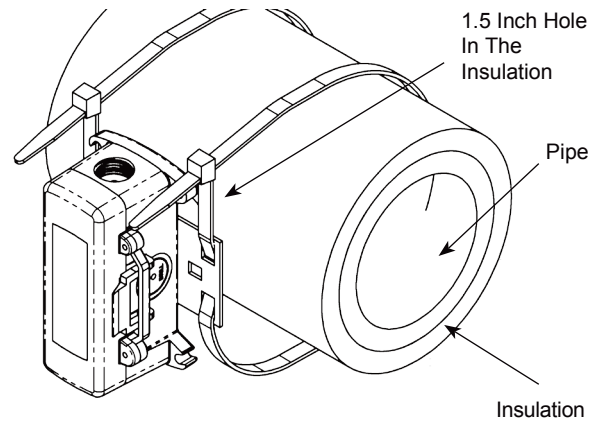

Figure 8: Typical Spring-loaded (-STP) Installation

Application: This sensor reads the fluid temperature in a pipe by reading the temperature of the pipe. Properly installed strap sensors with insulation around the local strap-on sight will offer a very accurate temperature of the water inside the pipe to within .5 °F or better of the inside pipe water temperature.

Clamp-On Unit Installation:

Figure 7 shows a typical installation for pipes from 2” to 4.5”. Stripping away insulation is OK. Larger pipes can be accommodated by adding another, customer supplied, stainless steel hose clamp.

1. If there is insulation, clean away a section of the pipe insulation a minimum of 2” all around the pipe. The copper sensor pad and SS strap must be in direct contact with the metal or plastic pipe. **NOTE** Nothing should be between the copper plate sensor and the bare pipe.
2. Tighten the clamp so that the sensor does not slide around the pipe and the foam is compressed no more than 50% allowing the copper sensor plate to form (bend) to the pipe curvature for maximum temperature conduction. Carrier recommends pre-forming the copper plate by bending it around the pipe with your fingers.
3. After the clamp-on sensor is securely mounted, add insulation a minimum of 1” thick and a minimum of 4 pipe diameters on each side of the copper sensor pad. (Example: A 2” pipe should have 8” of insulation on each side of the sensor). Only cover the sensor box to the top of the metal cover plate or to the BB door hinge so termination and servicing can be completed.
4. Terminate per the instructions in “Wiring and Termination”.

Strap Spring-loaded Unit Installation:

Figure 8 shows a typical installation for insulated pipes from 5” to 14”. Insulation thickness accommodated is 0.5” to 2.5”. Larger pipes can be accommodated by adding another, customer supplied, tie rap strap.

1. Make a 1.5 inch diameter hole in the insulation where the sensor is to be placed and clean the pipe from debris. Extend the spring so that the copper sensor pad is in direct contact with the metal or plastic pipe. **NOTE** No debris should be between the copper plate sensor and the bare pipe. The spring can retract to a minimum insulation thickness of ~.5” compressed to ~2.5” extended.
2. Position the box and sensor over the hole.
3. Tighten the strap so that the sensor spring is compressed no more than 50% allowing the copper sensor plate to form (bend) to the pipe curvature for maximum temperature conduction. Carrier recommends pre-forming the copper plate by bending it around the pipe with your fingers. Extend the spring further by turning it clockwise if the copper sensor plate contact is questionable. The copper sensor plate must be in direct contact with the pipe.
4. After the strap sensor is securely mounted, add insulation back in (backfill) around the spring extension, using the removed insulation, so that no heat or cold from the pipe can escape.
5. If more insulation is desired, cover the sensor box only to the top of the metal cover plate or to the BB door hinge so termination and servicing can be completed.
6. Terminate per the instructions in “Wiring and Termination”.

#20911 – 2/15/18

Wiring and Termination

Carrier recommends using twisted pair of at least 22AWG for all wire connections. Larger gauge wire may be required for long runs. All wiring must comply with the National Electric Code (NEC) and local codes. Do NOT run this device's wiring in the same conduit as high or low voltage AC power wiring. Tests show that inaccurate signal levels are possible when AC power wiring is present in the same conduit as the sensor wires.

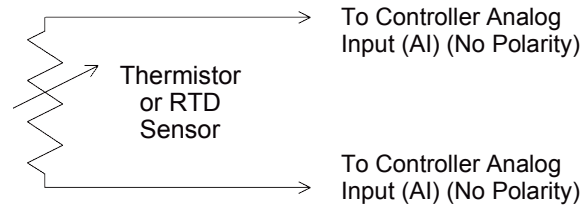

Figure 9: 2 Wire Lead Wire Termination for Thermistor or RTD

Diagnostics

Possible Problem:

Controller reports higher or lower than actual temperature

Possible Solutions:

- Confirm the input is set up correctly in the front end software
- Check wiring for proper termination and continuity (shorted or open).
- Disconnect wires and measure sensor resistance and verify the "Sensor" output is correct.