

Overview

The Voltage Converter is a cost-effective way of converting 24 VAC or VDC to 5 to 24 VDC for use on peripheral devices that require DC voltage. The converter is available with a 350 mA output.

The Voltage Converter's EZ mounting system allows for 2.75" snaptrack, DIN rail, or surface mounting.

Although most room units can run on 24 VAC power, converting to DC power eliminates the AC power "noise" which can affect the room sensor readings. Tests show that fluctuating and inaccurate signal levels are possible when AC power wiring is present in the same cable as the signal lines. To minimize the AC voltage noise, the DC converter must be mounted as close to the controller as physically possible. Do not mount the converter at the sensor end of the wire, the AC will still couple into the sensor signal if you do.

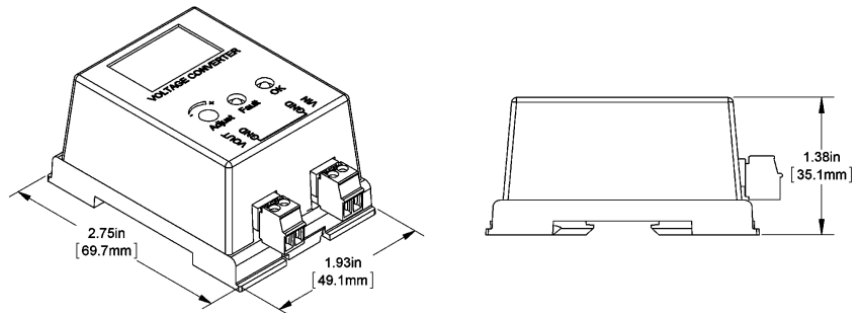

Figure 1: Voltage Converter
Part # NSB-VC350A-EZ-ADJ

Specifications

Output Voltage 5 to 24 VDC @ 350 mA
Recommended Input Voltage 18 to 28 VAC, 24 VDC (15 VA)

Input Voltage Limits

Model of Unit	Minimum (VAC/VDC)	Maximum (VAC/VDC)	Input Current @ Min Input Volts (AC/DC)
24V	24.0/31.0*	28.0/35.0	16.7 VA/325 mA

*Depends on output voltage

Environmental Operation Range 0 to 95% RH non-condensing
 -40 to 149°F (-40 to 65°C) 350 mA @ any output voltage
 -40 to 158°F (-40 to 70°C) 350 mA @ 5 VDC
 330 mA @ 10 VDC
 280 mA @ 12 VDC
 224 mA @ 15 VDC
 140 mA @ 24 VDC

Environmental Storage Range -40 to 176°F (-40 to 80°C)

Wiring 4 wires, 16 to 22 gauge

Rectification Half-Wave Rectified

Grounding AC and DC Ground are Common

NOTE The Voltage Converter is a Class 2 circuit when it is powered from a UL Class 2 power supply.

Mounting



This unit should be mounted at or within 2 feet of the control panel. DO NOT mount near or directly behind your room sensor.



The Voltage Converter is intended to convert the AC power provided at the panel to DC. Tests show that fluctuating and inaccurate peripheral device signal levels are possible when AC power wiring is present in the same conduit as the signal lines.

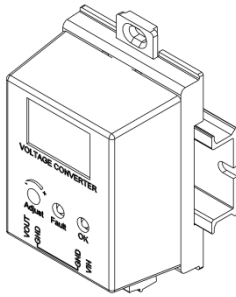

Figure 2: EZ-Mount on a DIN Rail

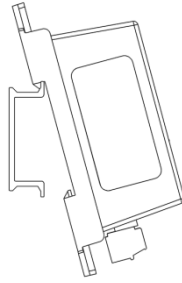

Figure 3: Catch EZ Mount hook on DIN rail before rotating sensor into place

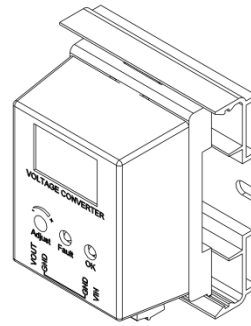

Figure 4: EZ-Mount in Snaptrack

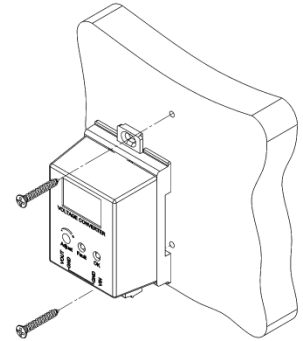

Figure 5: EZ-Mount Screwed to a Surface

MOUNTING TABS

The EZ mount base has mounting tabs that can be extended or pushed in. See Figures 6 and 7.

Din Rail Mounting, Figure 2

1. If not showing, pull the blue mounting tabs out as shown in Figure 7.
2. Catch EZ mount hook on DIN rail as shown in Figure 3.
3. Rotate the unit down until the bottom mounting tab snaps into place on the DIN rail.

Snap Track Mounting, Figure 4

If showing, push the blue mounting tabs in as shown in Figure 6. The edges of the EZ mount base will fit into the board slots in 2.75 inch snap track.

Screwed to a Surface, Figure 5

1. If not showing, pull the blue mounting tabs out as shown in Figure 7.
2. Place the unit against the surface and mark the screw holes.
3. Drill 1/8" pilot holes for #8 flathead screws.
4. Screw unit to surface.

NOTE The mounting holes in the blue mounting tabs are elongated to allow for alignment.

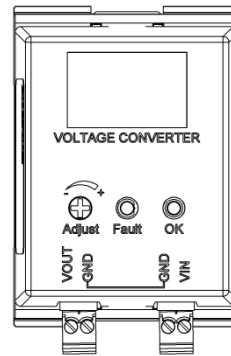

Figure 6: EZ-Mount with mounting tabs pushed in

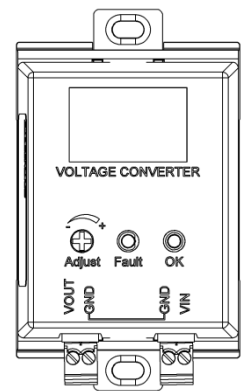

Figure 7: EZ-Mount with mounting tabs extended

Termination

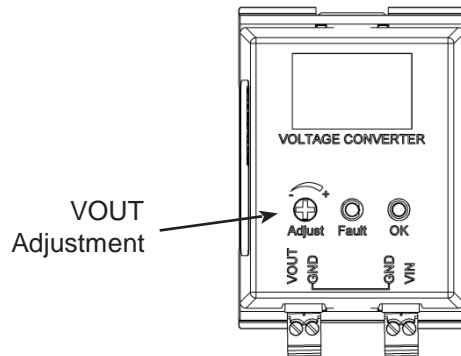

Figure 8: Wiring Terminals

Terminal	Function
VOUT	VDC out to peripheral devices
GND	VDC out ground or common
GND	VAC or VDC input ground or common
VIN	VAC or VDC input from transformer or other power supply

NOTE The terminals use a rising block screw terminal to hold the wires. It is possible for the block to be in a partially up position allowing the wire to be inserted under the block. Be sure that the connector screws are turned fully counterclockwise before inserting the wire. Lightly tug on each wire after tightening to verify proper termination.

Diagnostics

Red or Fault	Green or OK	Condition	Solution
LED OFF	LED ON	Normal Operation	
LED ON	LED ON	Unstable condition, excessive load on the output	Reduce the output Load
LED OFF	LED OFF	No input power	Check for Proper Voltage
LED ON	LED OFF	Output shorted to Ground	Remove power, find and remove VDC short