

Overview

The Carrier Compact Pressure Sensor is a true differential pressure transmitter that provides ± 5 inches W.C. ($\pm 1,250$ Pascals) in 10 field selectable ranges (see specifications). The enclosure is designed for DIN rail, Snaptrack or surface mounting. Three output ranges of 0 to 5 VDC, 0 to 10 VDC, and 4 to 20 mA are also field-selectable for all pressure ranges. The wiring terminal block is depluggable. Pressure units are available in Inches of Water Column or Pascals.

Part #s NSB-ZPS-SR-EZ-ST-IN
NSB-ZPS-SR-EZ-ST-PA

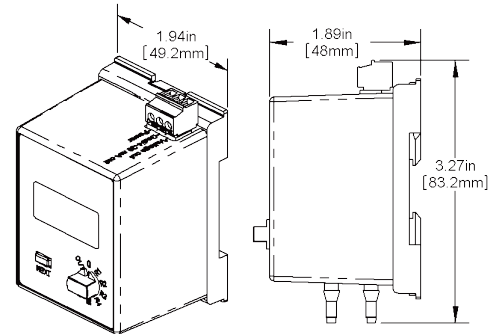

Figure 1: Pressure Sensor

Specifications

Power

7 to 40 VDC (4 to 20 mA Output)
7 to 40 VDC or 18 to 28 VAC (0 to 5 VDC Output)
13 to 40 VDC or 18 to 28 VAC (0 to 10 VDC Output)

Power Consumption

20 mA max, DC only at 4 to 20 mA Output
4.9 mA max DC at 0 to 5 VDC or 0 to 10 VDC Output
0.12 VA max AC at 0 to 5 VDC or 0 to 10 VDC Output

Load Resistance

4 to 20 mA Output 850 Ω Maximum @ 24 VDC
0 to 5 VDC or 0 to 10 VDC output 1K Ω minimum

Accuracy at 72°F

$\pm 0.25\%$ of range

Stability

$\pm 0.25\%$ F.S. per year

Environmental Operation Range

14 to 140°F (-10 to 60°C)

Storage Temperature

-40 to 203°F (-40 to 95°C)

Temperature Error

0.01% FS/°F (0.02% FS/°C) (± 5.0 " W.C. @ -4 to 140°F [-20 to 60°C])

Overpressure

Proof: 27.68" W.C. (1 PSI),
Burst: 41.52" W.C. (1.5 PSI)

Wiring

3-wire removable terminal block (14 to 24 AWG)*
2 wires (4 to 20mA Current loop)*
3 wires (AC or DC powered, Voltage out)*

Humidity

0 to 95% RH, non-condensing

Port Connection

1 High Pressure and 1 Low Pressure
for push-on 1/4-inch tubing (1/8" to 3/16" I.D.)

Enclosure Material

ABS Plastic, UL94, V-0

Mounting

DIN Rail, Snaptrack or Surface Mountable

Mounting

The mounting base has mounting tabs that can be extended or pushed in for the three mounting methods.

DIN Rail Mounting, Figures 2-3.

1. Pull out the blue mounting tabs.
2. Catch the mount hook on DIN rail as shown in Figure 3.
3. Rotate the pressure sensor down until the bottom mounting tab snaps into place on the DIN rail.
4. Connect wires and pressure lines as needed.

Snaptrack Mounting, Figure 4.

1. Push in the blue mounting tabs.
2. Snap the mounting base into the board slots in the 2.75 inch snaptrack.
3. Connect wires and pressure lines as needed.

Surface Mounting, Figure 5

1. Pull out the blue mounting tabs.
2. Place the pressure sensor against the surface and mark the screw holes.
3. Drill 1/8" pilot holes for #8 flathead screws.
4. Screw unit to the surface. The holes in the blue mounting tabs are elongated to allow for alignment.
5. Connect wires and pressure lines as needed.

DIN Rail Mount

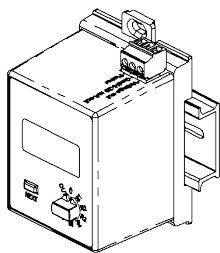

Figure 2: DIN Rail Mounting with tabs out.

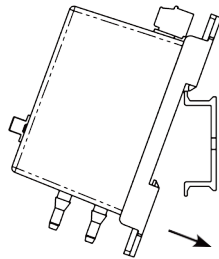

Figure 3: Catch the mounting hook on the edge of the DIN Rail, then rotate into place.

Snaptrack Mount

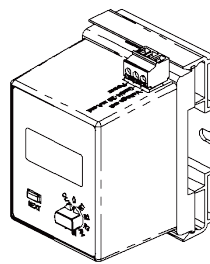

Figure 4: Snaptrack mounting with tabs in

Surface mount

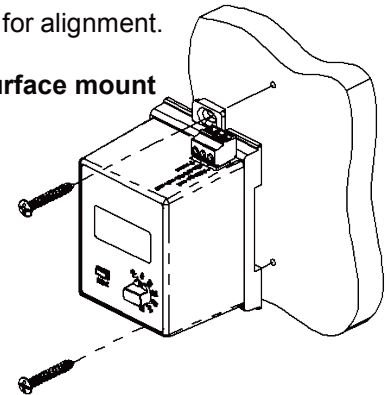

Figure 5: Surface mounting with the tabs out.

Pressure Connections

The Pressure ports will accept 1/4" tubing (1/8" or 3/16" ID).

- Connect the high pressure to the port labeled High
- Connect the low pressure to the port labeled Low

The output will be the pressure difference between the high and low port.

NOTE Remove blue dust covers from pressure ports before use.

Figure 6: Pressure Port Connections

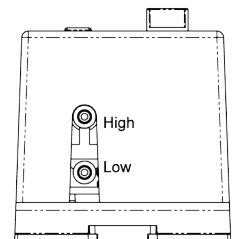

Wiring Termination



Carrier recommends wiring the product with power disconnected. Proper supply voltage, polarity and wiring connections are important to a successful installation. Not observing these recommendations may damage the product and void the warranty.

Table 1: Pressure Sensor Termination

Output Signal	Power Terminal	Gnd/4-20mA Terminal	Voltage Output Terminal
4 to 20 mA	7 to 40 VDC	4 to 20 mA Signal To Controller Analog Input	Not Used
0 to 5 VDC	7 to 40 VDC or 18 to 28 VAC	To Controller Ground	0 to 5 VDC Signal To Controller Analog Input
0 to 10 VDC	13 to 40 VDC or 18 to 28 VAC	To Controller Ground	0 to 10 VDC Signal To Controller Analog Input

4 to 20 mA, 2-wire operation

- Connect the pressure sensor's Power terminal to a DC voltage of 7 to 40 VDC.
- Connect the Gnd/4-20 mA Out terminal to a 4-20mA input on your controller.
- The Voltage Out terminal is not used for 4 to 20 mA signaling.

0 to 5 V or 0 to 10 V, 3-wire operation

- Connect the pressure sensor's Power terminal to:
 - 7 to 40 VDC or 18 to 28 VAC (for 0 to 5 VDC output units)
 - 13 to 40 VDC or 18 to 28 VAC (for 0 to 10 VDC output units).
- Connect the terminal labeled Gnd/4-20 mA Out to the controller's ground.
- Connect the Voltage Out terminal to an analog input configured for voltage input.

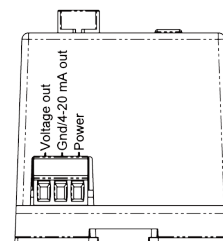

Figure 7: Wiring terminations

NOTE The terminals use a rising block screw terminal to hold the wires. It is possible for the block to be in a partially up position allowing the wire to be inserted under the block. Be sure that the connector screws are turned fully counterclockwise before inserting the wire. Lightly tug on each wire after tightening to verify proper termination.

Front Panel Operation

The rotary switch is used to select the pressure range, bi-directional or uni-directional pressure range, output range or to auto zero the unit. The notch in the knob indicates the switch position. The rotary switch in Figure 8 indicates 0 (zero), showing that the switch is in the Auto Zero position.

Press the NEXT button to toggle between values when the rotary switch is in the +/- bi-directional or uni-directional pressure or OUT output range position. The NEXT button is also used to initiate 0 (Auto Zero) or change the display mode.

AUTO ZERO (Table 2)

- Connect the high and low ports together with a short length of tubing without kinks.
- Place the rotary switch into the 0 position. The display will show Aut0.
- Press the NEXT button. The display will show a series of progress bars starting with one bar and ending with four.
- When the Auto Zero is complete, the display will show "done" for about 4 seconds, then Aut0.
- Return the rotary switch to the desired pressure range (see Pressure Range on page 3).

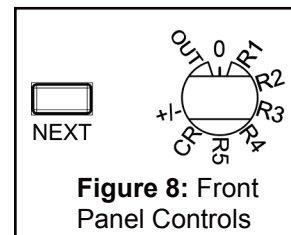

Figure 8: Front Panel Controls

Table 2: Auto Zero Display Sequence

Rotary Switch Position	Initial Display	After Pushing NEXT button	When Complete
	Aut0		done

Table 3: Output Range Display Sequence

Rotary Switch Position	4 to 20 mA output	0 to 5 VDC Output	0 to 10 VDC Output
	4-20	0-5	0-10

OUTPUT RANGE (Table 3)

- Place the rotary switch into the OUT position.
- Press the NEXT button until the desired output range is showing on the display.
- Return the rotary switch to the desired pressure range (see Pressure Range on page 3).

Front Panel Operation continued....

PRESSURE RANGE (Table 4)

Rotate the rotary switch to any of the positions labeled R1 through R5 or CR for a Custom Range. (**NOTE** Custom Range units will have the pressure range printed on the label.) The display will show the pressure range for 2 to 4 seconds, and then the display shows the differential pressure across the ports. Inches of Water Column (WC) or Pascal units are selected at the time of order.

UNI-DIRECTIONAL OR BI-DIRECTIONAL RANGE (Table 5)

All pressure ranges can be made uni-directional or bi-directional.

- Place the rotary switch into the +/- position. The directional mode will show on the display.
- Press the NEXT button until the desired mode is showing on the display.
- Return the rotary switch to the desired pressure range.

Rotary Switch Position	Uni-Directional Pressure	Bi-Directional Pressure
	Un	-b

Rotary Switch Position	Inches W.C.	Pascals
	10 in	250 Pa
	20 in	300 Pa
	25 in	500 Pa
	30 in	1000 Pa
	50 in	1250 Pa

ACTIVE OR INACTIVE DISPLAY MODE

The pressure sensor can be in “active” or “inactive” display mode. In active display mode, the four-digit display shows the differential pressure from -5.0” to 5.0” WC or -1,250 to +1,250 Pascals, depending on model. In inactive display mode, the four-digit display simply shows On.

To switch display modes, follow the procedure below.

- Place the rotary switch into the blank position, see Figure 9.
- If the unit is in the active mode, the display will show either the In (inches of WC) or Pa (Pascals) icon. If it is in the inactive mode, the display will read On.
- Press and hold the NEXT button (approximately 7 seconds) to toggle to the desired mode.
- Return the rotary switch to the pressure range required

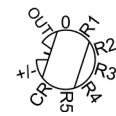

Figure 9: Rotary Switch Position for Display Mode Selection



Figure 10: Display message during “Inactive” Display Mode

Typical Applications

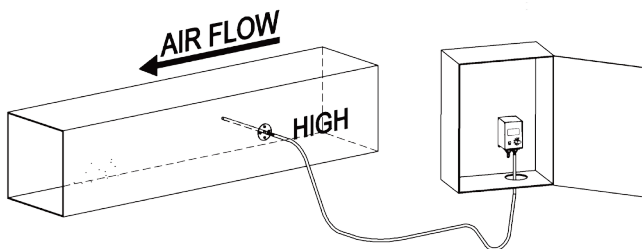

Figure 11: Duct static pressure monitoring with the pressure sensor mounted in a panel with a static probe (p/n NSB-ZPS-ACC07) in the duct.

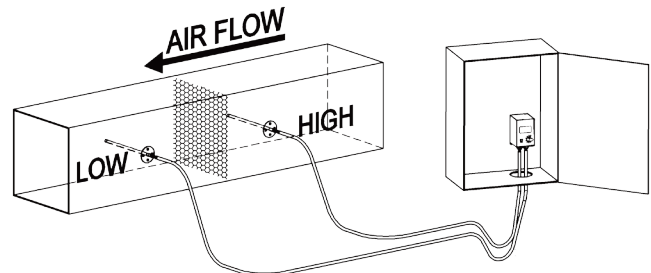

Figure 12: Air filter pressure drop monitoring with the pressure sensor mounted in a panel with two static pressure probes (p/n NSB-ZPS-ACC07) in the duct.

NOTE Best practice is to form a drip loop in the tubing to prevent condensation from reaching the sensor.



#26911 – 2/15/18

Troubleshooting

POSSIBLE PROBLEMS:

Display does not light

Output stuck either high or low

Output not tracking pressure properly

POSSIBLE SOLUTIONS:

- Check power connections for proper power (see specifications below).

- Remove pressure from ports and perform auto-zero procedure described on page 2.

- Remove pressure from ports and perform auto-zero procedure described on page 2.

Specifications subject to change without notice.