

Overview

The Low Pressure Sensor with display measures building pressure, air velocities and volumes. The heart of the unit is a micro-machined silicon pressure sensor.

The LCD display helps with troubleshooting because it displays the actual differential pressure over the entire operational range (-1.0 to +1.0 inches W.C.) regardless of which individual pressure range is selected for output to the system controller.

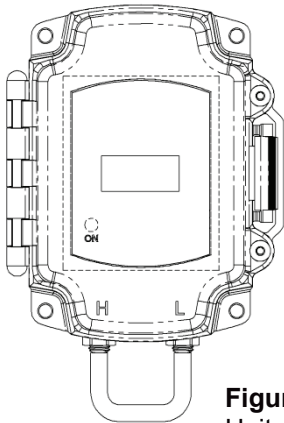

Figure 1:
Unit with Display
Part # NSB-ZPS-LR-BB-ST-D-IN

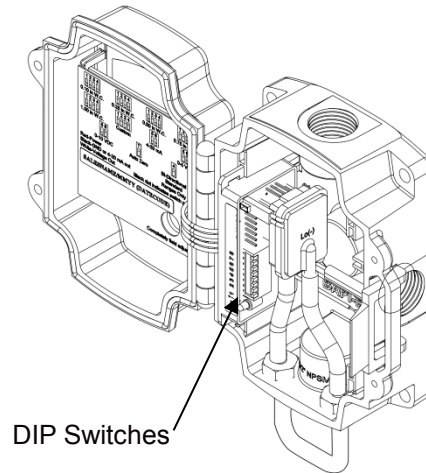

Figure 2:
Unit Open

CAUTION You must Auto-zero the sensor after it is installed. The position of the sensor affects the sensor's calibration.

Specifications

Power

- 7 to 40 VDC (4 to 20 mA Output)
- 7 to 40 VDC or 18 to 28 VAC (0 to 5 VDC Output)
- 13 to 40 VDC or 18 to 28 VAC (0 to 10 VDC Output)

Power Consumption

- 20 mA max, DC only at 4 to 20 mA Output
- 4.9 mA max DC at 0 to 5 VDC or 0 to 10 VDC Output
- 0.12 VA max AC at 0 to 5 VDC or 0 to 10 VDC Output

Load Resistance

- 4 to 20 mA Output 850 Ω Maximum @ 24 VDC
- 0 to 5 VDC or 0 to 10 VDC output 1KΩ minimum

Accuracy at 72°F

- ±0.5% of range 0 to 0.1", 0 to 0.25", ±0.1" and ±0.25" ranges
- ±0.25% of range all other ranges

Stability ±0.25% F.S. per year

Temperature Error

- 0.04% FS/°F (0.07% FS/°C) (±1.0" W.C. @ -4 to 140°F [-20 to 60°C])

Environmental Operation Range 14 to 140°F (-10 to 60°C)

Storage Temperature -40 to 203°F (-40 to 95°C)

Overpressure Proof: 27.68 in W.C. (1 PSI),
Burst: 41.52 in W.C. (1.5 PSI)

Wiring 2 wires (4 to 20mA Current loop)*
3 wires (AC or DC powered, Voltage out)*

Humidity 0 to 95% RH, non-condensing

Port Connection

- 1 High Pressure and 1 Low Pressure for push-on 1/4-inch tubing (1/8" to 3/16" I.D.)

Enclosure Material

- UV-resistant Polycarbonate, UL94, V-0

Enclosure Rating IP66, NEMA 4

Mounting Four external tabs with holes for #10 screws

Table 1: Pressure Ranges			
Inches Unit			
Range	Pressure	Range	Pressure
51	0 to 0.10 in W.C.	56	± 0.10 in W.C.
52	0 to 0.25 in W.C.	57	± 0.25 in W.C.
53	0 to 0.50 in W.C.	58	± 0.50 in W.C.
54	0 to 0.75 in W.C.	59	± 0.75 in W.C.
55	0 to 1.00 in W.C.	60	± 1.00 in W.C.

Specifications subject to change without notice.

Mounting

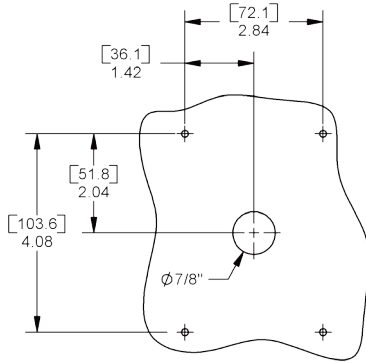

Figure 3: Mounting Hole Pattern **NOTE** Carrier recommends using #10 screws that require 5/32" pilot holes.

Attach the unit to its mounting surface with four #10 screws through the holes in the mounting tabs. The preferred mounting orientation is with the pressure ports facing down.

NOTE Remove blue dust shields from pressure ports before use. Push tubing onto the port nipple. Avoid kinks and holes in the tubing or accuracy will be affected.

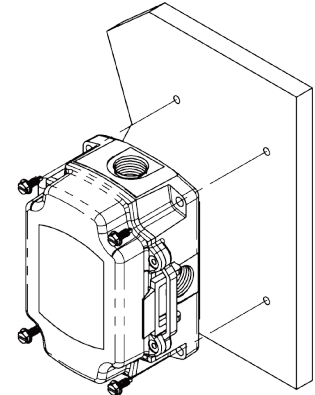

Figure 4: Mounting Screws Location

Output Termination



Carrier recommends wiring the product with power disconnected. Proper supply voltage, polarity and wiring connections are important to a successful installation. Not observing these recommendations may damage the product and void the warranty.

Table 2: Pressure Sensor Termination

Output Signal	Red Wire (V+)	Black Wire (Gnd or 4-20mA Return)	White Wire (Voltage Output)
4 to 20 mA	7 to 40 VDC	4 to 20 mA Signal To Controller Analog Input	Not Used
0 to 5 VDC	7 to 40 VDC or 18 to 28 VAC	To Controller Ground	0 to 5 VDC Signal To Controller Analog Input
0 to 10 VDC	13 to 40 VDC or 18 to 28 VAC	To Controller Ground	0 to 10 VDC Signal To Controller Analog Input

Current Loop Wiring: 4 to 20 mA is “two wire” operation. The sensor’s red wire connects to a positive direct current voltage of 7 to 40 VDC. The black wire becomes the return of the 4 to 20 mA signal. The white wire is not used but must be insulated from accidental contact with ground or any other potential. For 4 to 20 mA signaling, only direct current can be used to power the sensor.

Voltage Output Wiring: 0 to 5 V or 0 to 10 V is “three wire” operation. The sensor’s red wire connects to either 7 to 40 VDC or 18 to 28 VAC for 0 to 5 VDC output or 13 to 40 VDC or 18 to 28 VAC for 0 to 10 VDC output. The black wire is connected to ground and the white wire is connected to an analog input of the controller. The white wire is insulated in the factory before shipping, so remove the connector and strip the insulation from the white wire as desired.

To ensure that all wires are properly terminated, twist the stripped ends of each circuit together before inserting into the splice terminals. Gently tug on the wire after terminating to make sure of a good connection. If the wire comes out of the termination, repeat the splice procedure.

Dip Switch Settings

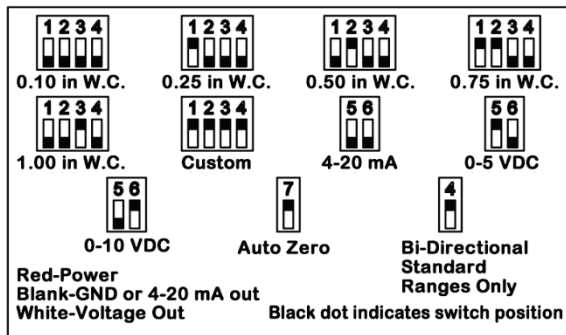

Figure 5:
DIP Switch Settings,
Inches W.C.

Pressure Range

To adjust the pressure range, set dip switches 1-4 to the desired pressure range using the the label found inside the cover of the unit (see Figure 5). Moving the Bi-Directional dip switch (#4) to the up position doubles the pressure range. For example, the 0 to 2.5" W.C. range becomes -2.5" to 2.5" W.C. if the Bi-Directional dip switch is in the up position.

NOTE If any of the switches are placed in an undefined combination the LED will blink at a fast rate and the output will be forced to 4mA or zero volts.

Output Range

To adjust the output range, set dip switches 5 and 6 to the desired output range using the the label found inside the cover of the unit (or shown on pg 2).

NOTE If any of the switches are placed in an undefined combination the LED will blink at a fast rage and the output will be forced to 4mA or zero volts.

Auto-Zero

To auto-zero the sensor, remove the tubing from the pressure ports (to remove the normal pressure source). Make sure that the pressure ports are sheltered from any drafts, including the technician's breath. Ideally the two ports should be connected together with a short piece of tubing.

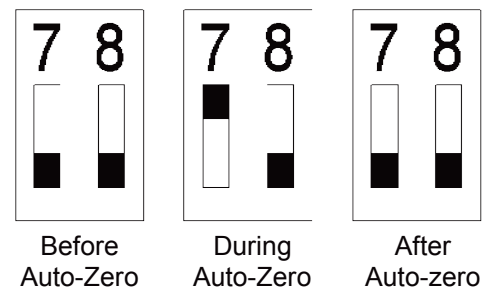
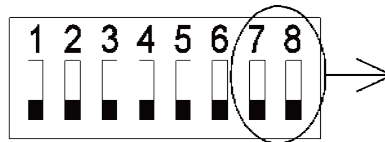

Figure 6: Auto-Zero Switch 7

Turn on switch 7 to start the auto-zero process. Switches 1 through 6 may be in any allowed configuration. The LED will blink at a fast rate and the output will be forced to zero (4mA or 0V) while the auto-zero is being performed. When the LED blinks at a slow rate, turn off switch 7 and reconnect the pressure source.

NOTE Switch 8 is reserved for Factory use. Leave it in the off position.

Typical Applications

Figure 7:

Duct static pressure monitoring, Pressure Sensor mounted in a panel with Part # NSB-ZPS-ACC07 in duct.

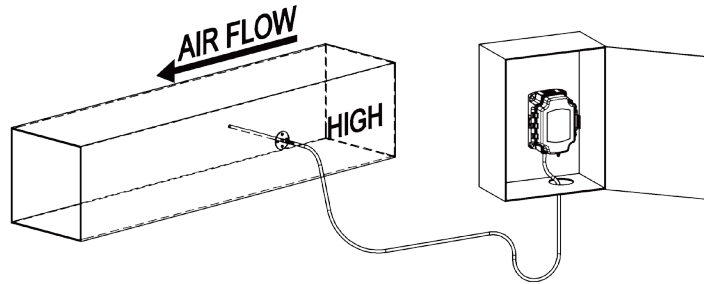

NOTE Best practice is to form a drip loop in the tubing to prevent condensation from reaching the sensor.

Figure 8:

Air filter pressure drop monitoring, Pressure Sensor mounted in a panel with two Part # NSB-ZPS-ACC07 in duct.

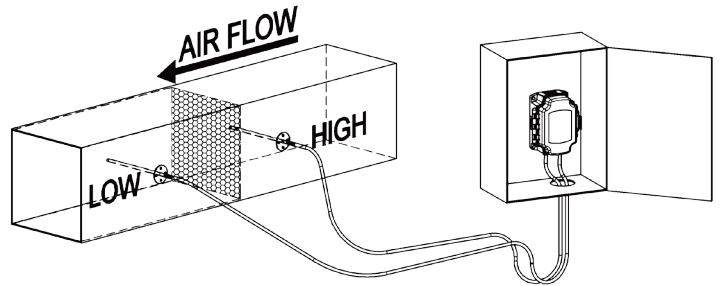
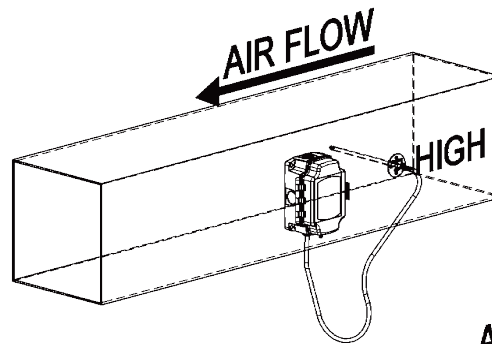

Figure 9:

Duct static pressure monitoring, Pressure Sensor mounted on the duct with Part # NSB-ZPS-ACC07 in duct.



NOTE Best practice is to form a drip loop in the tubing to prevent condensation from reaching the sensor.

Figure 10:

Air filter pressure drop monitoring, Pressure Sensor mounted on the duct with two Part # NSB-ZPS-ACC07 in duct.

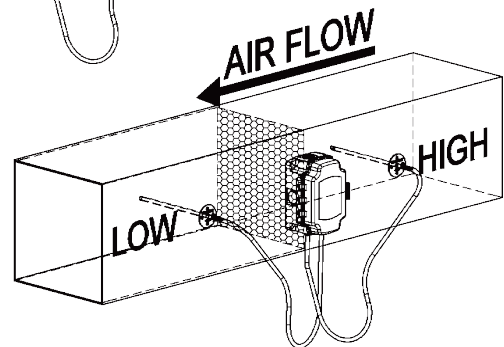

Troubleshooting

PROBLEMS:

LED does not light

LED is blinking fast
 (1/2 second on, 1/2 second off)

Output stuck (high or low)

Output not tracking pressure
 properly

POSSIBLE SOLUTIONS:

- Check power connections for proper power.
- The unit may be performing an auto-zero. Wait 10 seconds and check again.
- The dip switches are in an unsupported configuration, check the dip switch settings, both pressure and output, and change them to ranges desired.
- Remove pressure from ports and perform auto-zero procedure.
- Check dip switches for proper pressure range selection.
- Check dip switches for proper output range selection.

LED Operation

LED off	No power
LED blinking 1/2 sec. on, 1/2 sec. off	Auto-zero or dip switch in undefined configuration
LED on	Normal operation
LED blinking 1/2 sec. on, 4 sec. off	Auto-zero complete