

Overview

The CO₂ Duct Sensor is an accurate and reliable way of incorporating demand controlled ventilation. It measures CO₂ in ranges of 0 to 2000, 0 to 5000, 0 to 10000, and 0 to 50000 ppm with a field-selectable output of 0 to 5 or 0 to 10 VDC.

The Single Beam unit (Part # NSB-ACD05-D-BB) has been optimized for periodically unoccupied areas and features automatic background calibration over a long time period to reduce drift.

The Dual Channel 24/7 unit (Part # NSB-DCD05-D-BB) has been optimized for continuously occupied areas and features a 3-point calibration process.

Barometric pressure changes from altitude or weather can affect CO₂ sensors, even putting them outside of their specified accuracy. This unit has a built-in Barometric pressure sensor that continuously compensates the output for accurate readings despite the weather or altitude.

The CO₂ Duct Sensor samples duct air using an aspiration tube. Optional indication of the CO₂ level as “Good, Fair or Poor” is available as a 3-color LED for 0 to 2000 ppm range units (Part # NSB-ACD05-D-BB-LED or NSB-DCD05-D-BB-LED).

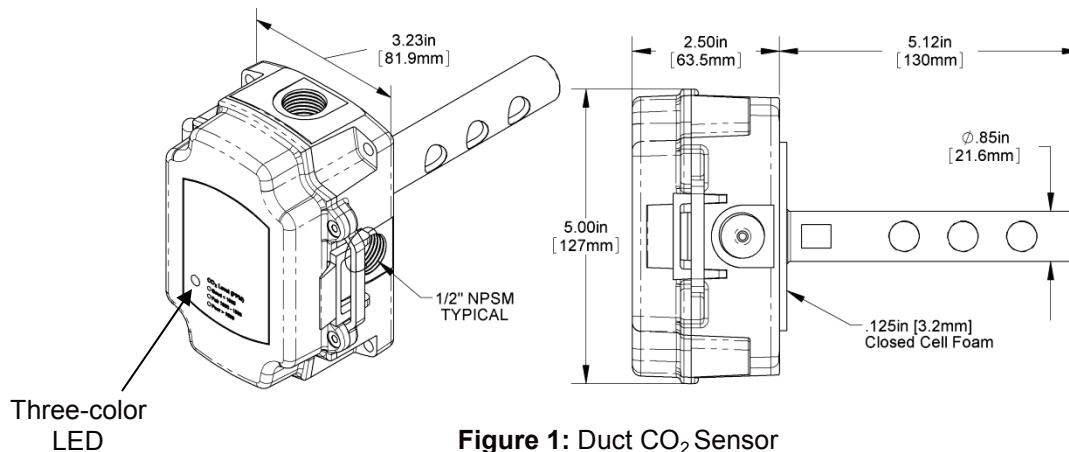

Figure 1: Duct CO₂ Sensor

Specifications

Power

12 to 24 VDC, 200 mA peak
18 to 24 VAC, 12 VA peak

CO₂ Sensing Elements

Single Beam Non-Dispersive Infrared (NDIR) or Dual Channel NDIR for “24/7” Model

Selectable Output

0 to 5 VDC or
0 to 10 VDC

Termination

3 terminals, 16 to 22 AWG

Wiring

2 pair

Operating Environment

32 to 122°F (0 to 50°C)
0 to 95%RH non-condensing

Enclosure Material

Polycarbonate, UL94 V-O

CO₂ Detection Range

0 to 2000
0 to 5000
0 to 10000
0 to 50000 ppm

Start-Up Time

10 minutes

Response Time

Less than 5 minutes (after start-up time)

CO₂ Accuracy

(Automatic Background Calib. Single Channel Model)

400 to 1250 ppm: ±30ppm or 3% of reading, whichever is greater

1,250 to 2,000 ppm: ±5% of reading + 30ppm

CO₂ Accuracy

(“24/7” Dual Channel model)

75ppm or 10% of reading (whichever is greater)

CO₂ Drift Stability (DCD “24/7” units)

<5% of full scale over life of product

Optional 3-Color LED (0 to 2,000 ppm range only)

Good, Green < 1000 PPM CO₂

Fair, Orange = 1000 to 1,500 PPM CO₂ Poor,

Red > 1500 PPM CO₂

Certifications

RoHS

Warranty Period

5 years from manufacture date

Specifications subject to change without notice.

Duct Unit Mounting

1. Carrier recommends placing the sensor in the middle of the duct wall, away from stratified air, to achieve the best reading. The unit should also be a minimum of 3 duct diameters from an elbow, damper or other duct restriction.
2. Drill a 1" hole for the aspiration probe.
3. Position the box so that airflow is directly into the holes on one side of the aspiration probe. There are no upstream or downstream holes, the air direction is not important.
4. Mount the enclosure to the duct using #10 screws through a minimum of two of the mounting tabs on opposite corners. A 1/8" pilot screw hole in the duct makes mounting easier. Use the enclosure mounting tabs to mark the pilot-hole locations.
5. Snug up the screws so that the foam backing is depressed to prevent air leakage but do not over-tighten or strip the screw threads.
6. Use the provided #6 screws to secure the cover for IP66 rating.
7. Carrier recommends sealing the conduit opening with fiberglass insulation.

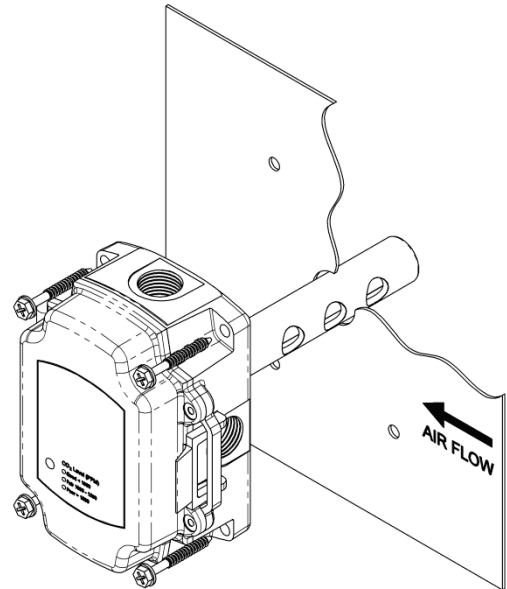

Figure 2: Duct unit mounting

Termination

Carrier recommends using twisted pair of at least 22 AWG and sealant filled connectors for all wire connections. Larger gauge wire may be required for long runs. All wiring must comply with the National Electric Code (NEC) and local codes. Do NOT run this device's wiring in the same conduit as AC power wiring. Tests show that fluctuating and inaccurate signal levels are possible when AC power wiring is present in the same conduit as the signal lines.



Carrier recommends wiring the product with power disconnected. Proper supply voltage, polarity, and wiring connections are important to a successful installation. Not observing these recommendations may damage the product and will void the warranty.

NOTE Unit is not ready for operation until the 10 minute start-up time has elapsed.

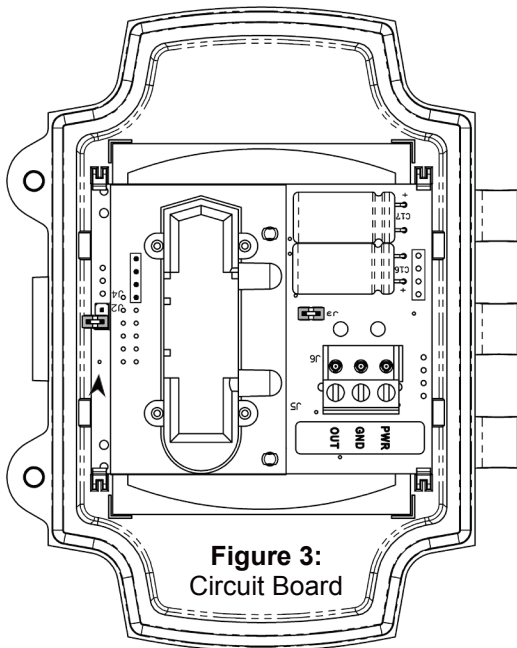

Figure 3:
Circuit Board

NOTE For proper operation, the jumper on calibration connector J2 must be connected to one leg.

Terminal	Function
PWR	12 to 24 VDC, 200 mA Peak 18 to 24 VAC, 12 VA Peak
GND	To controller Ground GND or Common
OUT	Voltage Output, CO ₂ Signal 0 to 5 or 0 to 10 VDC, Referenced to GND

The CO₂ outputs may be field configured for 0 to 5 VDC or 0 to 10 VDC outputs at any time. Set the jumpers on J3 as shown in Figures 4 and 5.

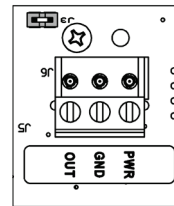

Figure 4: J3 set for 0 to 10 VDC output

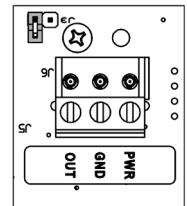

Figure 5: J3 set for 0 to 5 VDC output

Keeping the Enclosure Airtight After Termination

For the sensor to work correctly, the wiring entrance must remain airtight. If the CO₂ transmitter is mounted to a hollow wall and wired through its back, or wired with conduit, it is possible that a draft of clean air may fill the enclosure through the wiring opening. This draft may prevent the unit from measuring ambient CO₂. Carrier recommends plugging the conduit at the enclosure. Included with the CO₂ transmitter is a foam plug to seal the ½ inch EMT. Place the wires into the plug as shown in Figure 6 and then insert the plug into the conduit sealing the conduit.

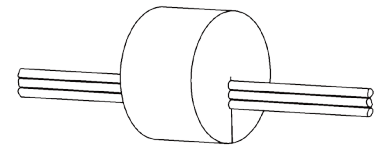

Figure 6:
Wires Through Foam Plug

Diagnostics

Possible Problems:

General troubleshooting

Possible Solutions:

Verify that the input is set up correctly in the controller and building automation software.

Check wiring at the sensor and controller for proper connections.

Check for corrosion at either the controller or the sensor. Clean off the corrosion, restrip the interconnecting wire and reapply the connection. In extreme cases, replace the controller, interconnecting wire and/or sensor.

Check the wiring between the sensor and controller. Label the terminals at the sensor end and the controller end. Disconnect the interconnecting wires from the controller and the sensor. With the wires disconnected, measure the resistance from wire-to-wire with a multimeter. The meter should read greater than 10 Meg-ohms, open or OL depending on the meter. Short the interconnecting wires together at one end. Go to the other end and measure the resistance from wire-to-wire with a multimeter. The meter should read less than 10 ohms (22 gauge or larger, 250 feet or less). If either test fails, replace the wire.

Check power supply/controller voltage supply.

Disconnect sensor and check power wires for proper voltage (see specifications on page 4).

Incorrect CO₂

Wait 15 minutes after a power interruption.

Check all BAS controller software parameters.

Determine if the sensor is exposed to an external environment different from the duct area that is being measured.