

TOSHIBA

Carrier

AIR CONDITIONER (MULTI TYPE)

Installation Manual



1117906101-1

Outdoor Unit

Model name:

<Heat Pump Model>

MMY-MAP0726HT6P-UL

MMY-MAP0966HT6P-UL

MMY-MAP1206HT6P-UL

MMY-MAP1446HT6P-UL

MMY-MAP1686HT6P-UL

For OUTDOOR USE only
Pour une UTILISATION EN EXTÉRIEUR
uniquement

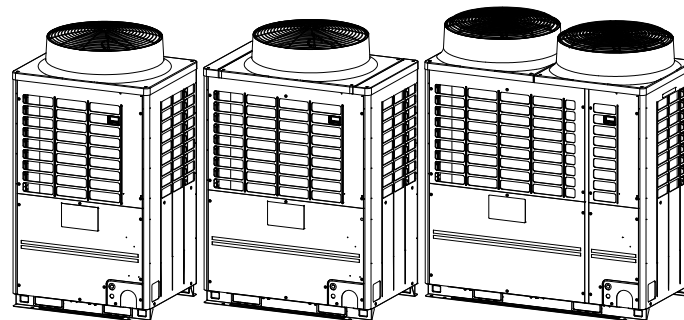

Installation Manual 1 English

Manuel d'installation 28 Français

ADOPTION OF NEW REFRIGERANT

This Air Conditioner uses R410A an environmentally friendly refrigerant.

Contents

1	Precautions for safety	2
2	Accessory parts	3
3	Installation of R410 air conditioner.	3
4	Selection of installation place.	4
5	Carrying in the outdoor unit	5
6	Installation of the outdoor unit	6
7	Refrigerant piping.	8
8	Electric wiring.	15
9	Address setting	18
10	Test run	24
11	Troubleshooting	25

Installing, starting up, and servicing air conditioning equipment can be hazardous due to system pressures, electrical components, and equipment location (roofs, elevated structures, etc.). Only trained, qualified installers and service mechanics should install, start up, and service this equipment. Untrained personnel can perform basic maintenance functions such as indoor unit air filter. All other operations should be performed by trained service personnel.

Before working on the equipment, observe precautions in the literature and on tags, stickers, and labels attached to the equipment.

Follow all safety codes. Wear safety glasses and work gloves. Use care in handling, rigging, and setting bulky equipment.

Read these instructions thoroughly and follow all warnings or cautions included in literature and attached to the unit. Consult local building codes and National Electrical Code (NEC) for special requirements. Recognize safety information. This is the safety alert symbol . When you see this symbol on the unit and in instructions or manuals, be alert to the potential for personal injury. Understand these signal words: DANGER, WARNING, and CAUTION. These words are used with the safety alert symbol.

DANGER identifies the most serious hazards which will result in severe personal injury or death. WARNING signifies hazards which could result in personal injury or death. CAUTION is used to identify unsafe practices which may result in minor personal injury or product and property damage. NOTE is used to highlight suggestions which will result in enhanced installation, reliability, or operation.

The manufacturer shall not assume any liability for the damage caused by not observing the description of this manual.

1 Precautions for safety

The manufacturer shall not assume any liability for the damage caused by not observing the description of this manual.

WARNING

General

- Carefully read Owner's Manual before starting the air conditioner. There are many important things to keep in mind for daily operation.
- Ask for installation to be performed by the dealer or a professional. Only a qualified installer is able to install an air conditioner. If a non-qualified person installs an air conditioner, it may result in problems such as fire, electric shock, injury, water leakage, noise and vibration.
- Do not use any refrigerant different from the one specified for complement or replacement. Otherwise, abnormally high pressure may be generated in the refrigeration cycle, which may result in a failure or explosion of the product or an injury to your body.
- Before opening the service panel of the outdoor unit, set the circuit breaker to the OFF position. Failure to set the circuit breaker to the OFF position may result in electric shocks through contact with the interior parts.
- Before carrying out the installation, maintenance, repair or removal work, be sure to set the circuit breakers for both the indoor and outdoor units to the OFF position. Otherwise, electric shock may result.
- Wear protective gloves and safety work clothing during installation, servicing and removal.
- Do not touch the aluminium fin of the outdoor unit. You may injure yourself if you do so. If the fin must be touched for some reason, first put on protective gloves and safety work clothing, and then proceed.
- Do not climb onto or place objects on top of the outdoor unit. You may fall or the objects may fall off of the outdoor unit and result in injury.
- Before cleaning the filter or other parts of the outdoor unit, set the circuit breaker to OFF without fail, and place a "Work in progress" sign near the circuit breaker before proceeding with the work.
- The refrigerant used by this air conditioner is the R410A.
- The air conditioner must be transported in stable condition. If any part of the product are broken, contact your distributor.

Selection of installation location

- Do not install in a location where flammable gas leaks are possible. If the gas should leak and accumulate around the unit, it may ignite and cause a fire.
- During transporting the air conditioner, wear shoes with protective toe caps, protective gloves, and other protective clothing.
- To transport the air conditioner, do not take hold of the bands around the packing carton. You may injure yourself if the bands should break.
- Places where the operation sound of the outdoor unit may cause a disturbance. (Especially at the boundary line with a neighbour, install the air conditioner while considering the noise.)

Installation

- The designated bolts (M12) and nuts (M12) for securing the outdoor unit must be used when installing the unit.
- Install the outdoor unit properly in a location that is durable enough to support the weight of the outdoor unit. Insufficient durability may cause the outdoor unit to fall, which may result in injury.
- Install the unit in the prescribed manner for protection against strong wind and earthquake. Incorrect installation may result in the unit falling down, or other accidents.
- Fix the screws back which have been removed for installation or other purposes.

Refrigerant piping

- Install the refrigerant pipe securely during the installation work before operating the air conditioner. If the compressor is operated with the valve open and without refrigerant pipe, the compressor sucks air and the refrigeration cycles is over pressurized, which may cause a injury.
- Tighten the flare nut with a torque wrench in the specified manner. Excessive tighten of the flare nut may cause a crack in the flare nut after a long period, which may result in refrigerant leakage.
- When the air conditioner has been installed or relocated, follow the instructions in the Installation Manual and purge the air completely so that no gases other than the refrigerant will be mixed in the refrigerating cycle. Failure to purge the air completely may cause the air conditioner to malfunction.
- Nitrogen gas must be used for the airtight test.

Electrical wiring

- Only a certified installer or qualified service person(*1) is allowed to carry out the electrical work of the air conditioner.
- When connecting the electrical wires, repairing the electrical parts or undertaking other electrical jobs, wear gloves to provide protection for electricians and from heat, insulating shoes and clothing to provide protection from electric shocks. Failure to wear this protective gear may result in electric shocks.
- When executing address setting, test run, or troubleshooting through the checking window on the electric parts box, put on insulated heat-proof gloves, insulated shoes and other clothing to provide protection from electric shock. Otherwise you may receive an electric shock.
- Use wiring that meets the specifications in the Installation Manual, NEC and the local codes.
- Check that the product is properly grounded.
- Do not connect the ground line to a gas pipe, water pipe, lightning conductor, or a telephone ground line.
- After completing the repair or relocation work, check that the ground wires are connected properly.
- Install a circuit breaker that meets the specifications in the installation manual, NEC and local codes.
- Under no circumstances must the power cable be extended. Connection trouble in the places where the cable is extended may give rise to smoking and/or a fire.
- Do not supply power from the power terminal block equipped on the outdoor unit to another outdoor unit. Capacity overflow may occur on the terminal block and may result in fire.
- Each outdoor unit should have its own power supply.

Test run

- Before operating the air conditioner after having completed the work, check that the electrical parts box cover of the indoor unit and service panel of the outdoor unit are closed, and set the circuit breaker to the ON position. You may receive an electric shock if the power is turned on without first conducting these checks.
- If there is any kind of trouble (such as when a check code display has appeared, there is a smell of burning, abnormal sounds are heard, the air conditioner fails to cool or heat or water is leaking) has occurred in the air conditioner, do not touch the air conditioner yourself but set the circuit breaker to the OFF position, and contact a qualified service person. Take steps to ensure that the power will not be turned on (by marking "out of service" near the circuit breaker, for instance) until qualified service person arrives. Continuing to use the air conditioner in the trouble status may cause mechanical problems to escalate or result in electric shocks or other failure.
- Upon completion of the installation work, check for refrigerant leaks and check the insulation resistance and water drainage. Then conduct a test run to check that the air conditioner is operating properly.

Explanations given to user

- Upon completion of the installation work, tell the user where the circuit breaker is located. If the user does not know where the circuit breaker is, he or she will not be able to turn it off in the event that trouble has occurred in the air conditioner.
- If the fan grille is damaged, do not approach the outdoor unit but set the circuit breaker to the OFF position, and contact a qualified service person(*1) to have the repairs done. Do not set the circuit breaker to the ON position until the repairs are completed.
- After the installation work, follow the Owner's Manual to explain to the customer how to use and maintain the unit.

Relocation

- Only a certified installer(*1) or service person is allowed to relocate the air conditioner.
- When the pump-down work is carried out shut down the compressor before disconnecting the refrigerant pipe. Disconnecting the refrigerant pipe with the service valve left open and the compressor still operating will cause air or other gas to be sucked in, raising the pressure inside the refrigeration cycle to an abnormally high level, and possibly resulting in rupture, injury or other trouble.
- Do not recover the refrigerant into the outdoor unit. Use a refrigerant recovery machine to recover the refrigerant after moving or repairing. It is impossible to recover the refrigerant into the outdoor unit. Refrigerant recovery into the outdoor unit may result in serious accidents such as explosion of the unit, injury or other accidents.

(*1) Refer to the "Definition of Qualified Installer or Qualified Service Person."

⚠ CAUTION

• THIS AIR CONDITIONER USES THE ENVIRONMENTALLY FRIENDLY HFC REFRIGERANT (R410A) WHICH DOES NOT DESTROY OZONE LAYER.

2 Accessory parts

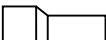
Part name	Q'ty		Shape	Usage
	MAP072, MAP096 type	MAP120, MAP144, MAP168 type		
Owner's Manual	1	1	–	(Be sure to hand it to the customers.)
Installation Manual	1	1	–	This manual for installer.
Accessory pipe (for Ø7/8" (22.2 mm))	1	–		Connecting pipe for gas side piping
Accessory pipe (for Ø1 1/8" (28.6 mm))	–	1		Connecting pipe for gas side piping

3 Installation of R410 air conditioner

This air conditioner adopts the HFC refrigerant (R410A) which does not deplete the ozone layer.

- To prevent mixing of refrigerant or refrigerating oil, the size of the charge port of the main unit or connecting section of the installation tool differs to that of an air conditioner for the former refrigerant. Accordingly, exclusive tools are required for the new refrigerant (R410A) as shown below.
- For connecting pipes, use new and clean piping materials so that water or dust does not enter.

■ Required Tools and Cautions on handling

Prepare the tools and equipment listed in the following table before starting the installation work.

△: R410A exclusive

◎: Generic

Tools/equipment	Use	
Manifold gauge*	Vacuuming/charging refrigerant and operation check	△
Charging hose		△
Gas leak detector	Gas leak check	△
Vacuum pump with backflow prevention function	Vacuum drying	◎
Flare tool	Flare machining of pipes	◎ Usable if dimensions are adjusted.
Bender	Bending pipes	◎
Refrigerant recovery equipment	Refrigerant recovery	△
Torque wrench	Tightening flare nuts	△ Ø1/2" (12.7 mm) and Ø5/8" (15.9 mm)
Pipe cutter	Cutting pipes	◎
Brazing torch and nitrogen cylinder	Braze pipes	◎
Refrigerant charging scales	Charging refrigerant	◎
4 mm hexagon wrench	Opening liquid valve	

4 Selection of installation place

Upon customer's approval, install the air conditioner in a place which satisfies the following conditions:

- Place where it can be installed horizontally.
- Place which can reserve a sufficient service space for safe maintenance or checks.
- Place where there is no problem even if the drained water overflows.

Avoid the following places:

- Salty places (seaside area) or places with much gas sulfide (hot spring area) (If selecting such a place, special maintenance is required.)
- Places where oil (including machine oil), steam, oil smoke or corrosive gas is generated.
- Places where an organic solvent is used.
- Chemical plants with a cooling system using liquid carbon dioxide.
- Places where a device generating high frequency (inverter, non-utility generator, medical apparatus, or communication equipment) is set. (Malfunction or abnormal control of the air conditioner, or interference to devices listed above may occur.)
- Places where discharged air from the outdoor unit blows against the windows of a neighbour's house.
- Places unable to bear the weight of the unit.
- Places with poor ventilation.

■ Installation space

Unit: in (mm)

Leave space necessary for running, installation and servicing.

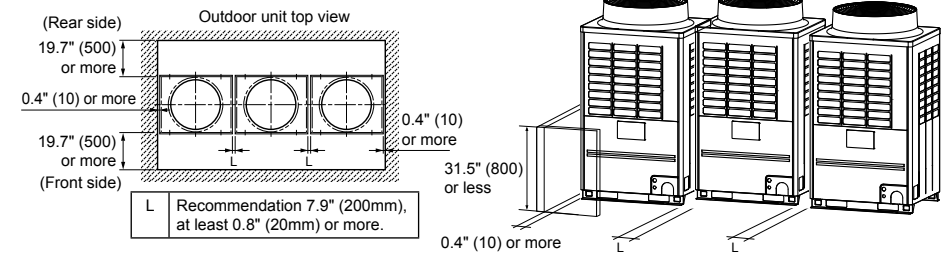
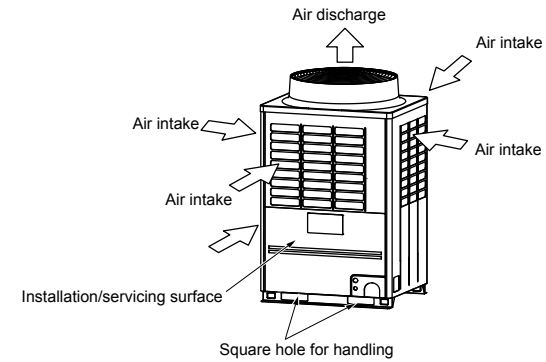

NOTE

- If there is an obstacle above the outdoor unit, leave a space of 78.7" (2000) or more to the top end of the outdoor unit.
- If there is a wall around the outdoor unit, make sure that its height does not exceed 31.5" (800).

▼ Combination of outdoor units

Model name (Standard Model)	Unit 1	Unit 2	Unit 3
	Header unit	Follower unit	Follower unit
MMY-MAP0726HT6P-UL	MMY-MAP0726*	-	-
MMY-MAP0966HT6P-UL	MMY-MAP0966*	-	-
MMY-MAP1206HT6P-UL	MMY-MAP1206*	-	-
MMY-MAP1446HT6P-UL	MMY-MAP1446*	-	-
MMY-MAP1686HT6P-UL	MMY-MAP1686*	-	-
MMY-AP1926HT6P-UL	MMY-MAP0966*	MMY-MAP0966*	-
MMY-AP2166HT6P-UL	MMY-MAP1206*	MMY-MAP0966*	-
MMY-AP2406HT6P-UL	MMY-MAP1446*	MMY-MAP0966*	-
MMY-AP2646HT6P-UL	MMY-MAP1446*	MMY-MAP1206*	-
MMY-AP2886HT6P-UL	MMY-MAP1446*	MMY-MAP1446*	-
MMY-AP3126HT6P-UL	MMY-MAP1686*	MMY-MAP1446*	-
MMY-AP3366HT6P-UL	MMY-MAP1686*	MMY-MAP1686*	-
MMY-AP3606HT6P-UL	MMY-MAP1206*	MMY-MAP1206*	MMY-MAP1206*
MMY-AP3846HT6P-UL	MMY-MAP1446*	MMY-MAP1206*	MMY-MAP1206*
MMY-AP4086HT6P-UL	MMY-MAP1446*	MMY-MAP1446*	MMY-MAP1206*
MMY-AP4326HT6P-UL	MMY-MAP1686*	MMY-MAP1446*	MMY-MAP1206*
MMY-AP4566HT6P-UL	MMY-MAP1686*	MMY-MAP1686*	MMY-MAP1206*

Model name (Space Saving Model)	Unit 1	Unit 2	Unit 3
	Header unit	Follower unit	Follower unit
MMY-AP192S6HT6P-UL	MMY-MAP1206*	MMY-MAP0726*	-
MMY-AP240S6HT6P-UL	MMY-MAP1206*	MMY-MAP1206*	-
MMY-AP288S6HT6P-UL	MMY-MAP1686*	MMY-MAP1206*	-
MMY-AP408S6HT6P-UL	MMY-MAP1686*	MMY-MAP1206*	MMY-MAP1206*

5 Carrying in the outdoor unit

⚠ CAUTION

Handle the outdoor unit carefully, observing the following items.

- To use a forklift or other machinery for loading/unloading in transportation, insert the fork of the forklift into the rectangular holes for handling as shown below.
- To lift up the unit, insert a rope capable of bearing the weight of the unit into the rectangular holes shown below. Tie the unit from 4 sides.
(Apply padding in positions where the rope comes in contact with the outdoor unit so that no damage is caused to the outer surface of the outdoor unit.)
(There are reinforcing plates on the side surfaces, so the rope cannot be passed through.)

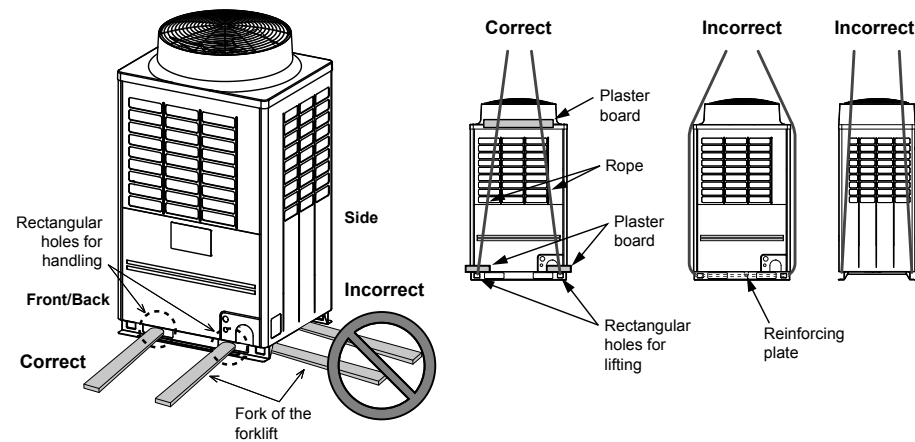

■ Weight center and weight

Unit: in (mm)

◆ Weight center of an outdoor unit

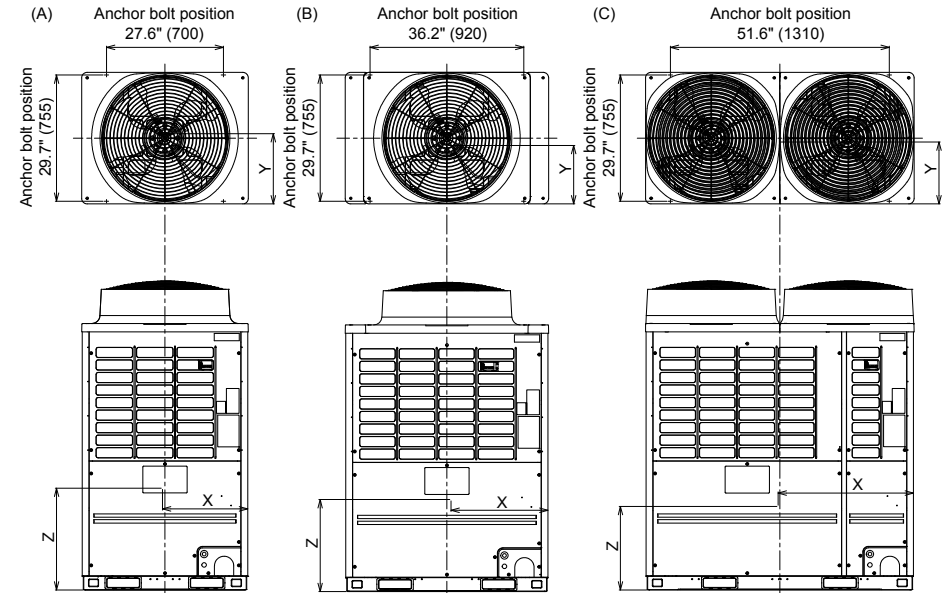

No.	Model type	X (in(mm))	Y (in(mm))	Z (in(mm))	Weight (lb(kg))
(A)	MAP0726HT6P-UL	20.1" (510)	16.5" (420)	24.0" (610)	574 (260)
(B)	MAP0966HT6P-UL	22.8" (580)	13.8" (350)	21.7" (550)	684 (310)
	MAP1206HT6P-UL				
(C)	MAP1446HT6P-UL	31.9" (810)	14.6" (370)	19.7" (500)	838 (380)
	MAP1686HT6P-UL				

6 Installation of the outdoor unit

⚠ WARNING

Install the outdoor unit securely in a location where the base can sustain the weight adequately. If strength is insufficient, the unit may fall down resulting in human injury.

⚠ CAUTION

- Drain water is discharged from the outdoor unit. (Especially while heating)
- Install the outdoor unit in a place with good drainage.
- For installation, be careful of the strength and level of the foundation so that abnormal sounds (vibration or noise) are not generated.

REQUIREMENT

Installation in a snowfall area

1. Install the outdoor unit on a higher foundation than the snowfall or set up a stand to install the unit so that snowfall will not affect the unit.
 - Set up a stand higher than the snowfall.
 - Apply an angled structure to the stand so that drainage will not be prevented. (Avoid using a stand with a flat surface.)
2. Mount a snowfall-hood onto the air inlet and the air outlet.
 - Leave enough space for the snowfall-hood so that it will not be an obstacle for the air inlet and the air outlet.

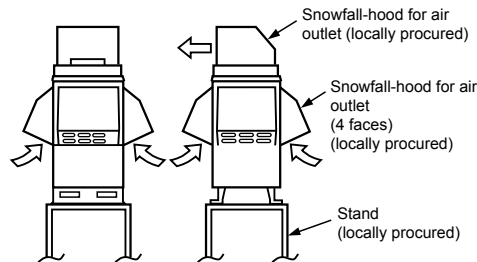

1. To install multiple outdoor units, arrange them with 7.9" (200mm) (recommendation, at least 0.8" (20mm)) or more spaces in between. Fix each outdoor unit with M12 anchor bolts at 4 positions. 0.8" (20mm) projection is appropriate for an anchor bolt.

Unit: in (mm)

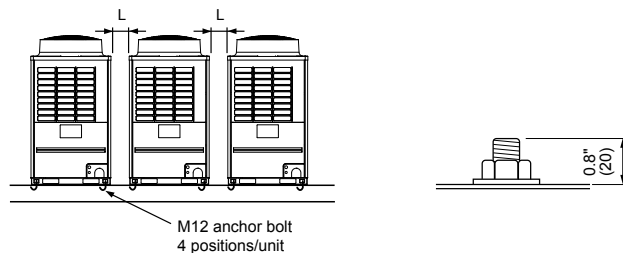

L Recommendation 7.9" (200mm), at least 0.8" (20mm) or more.

- Anchor bolt positions are as shown below:

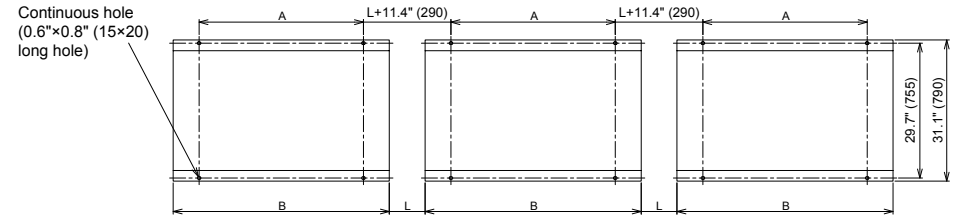

Model type	A	B	L
MAP0726	27.6" (700)	39.0" (990)	Recommendation 7.9" (200), at least 0.8" (20) or more
MAP0966, MAP1206	36.2" (920)	47.6" (1210)	
MAP1446, MAP1686	51.6" (1310)	63.0" (1600)	

2. To draw out the refrigerant pipe from the underside, set the height of the stand to 19.7" (500mm) or more.
3. Do not use 4 stands on the corner to support the outdoor unit.

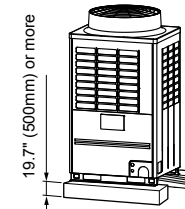

Incorrect

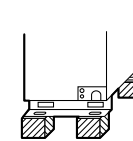

Correct

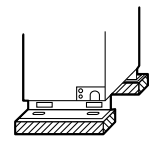

4. If vibration-proof rubbers (including vibration-proof blocks) are used, fit them under the whole clamping legs.

Correct

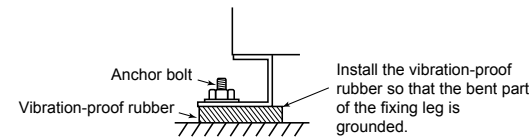

Correct

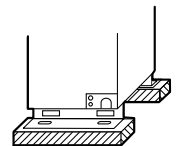

Incorrect

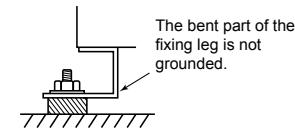

Incorrect

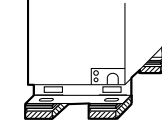

Incorrect

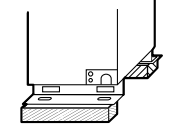

5. When multiple units are connected header unit must have the largest capacity.

- Connect the header unit to the main pipe. (Figure 1 and 3)
- Use a T-shaped branch joint (RBM-BT14UL/RBM-BT24UL: separately purchased) to connect the liquid line of each outdoor unit.
- Connect of the Outdoor unit connection piping kit for the liquid side in the right direction. (As shown in Figure 2, a Outdoor unit connection piping kit cannot be attached so that the refrigerant of the main pipe flows directly into the header unit.)

Liquid piping

▼ Figure 1

Correct

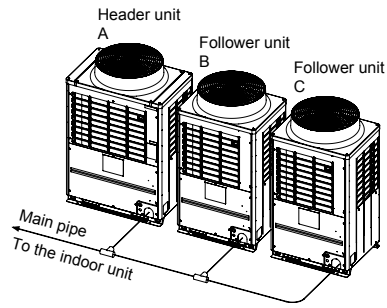

▼ Figure 2

Incorrect

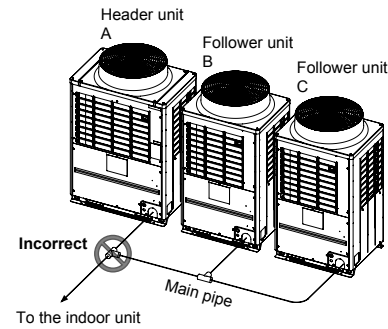

When drawing pipes downward

▼ Figure 5

Correct

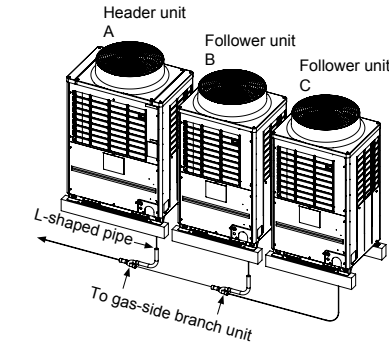

[Vertical connection of branch units]

▼ Figure 6

Incorrect

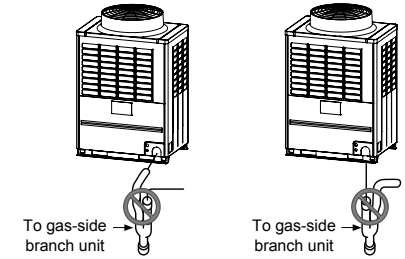

Gas piping

▼ Figure 3

Correct

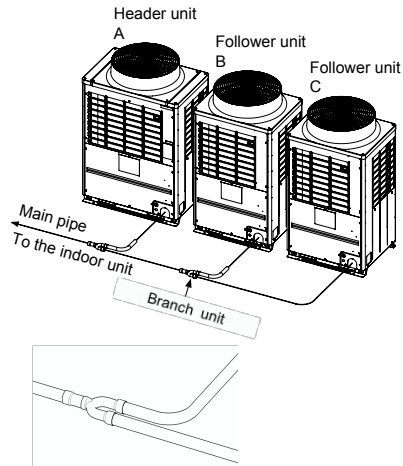

[Inverse connection of a gas-side branch unit]

▼ Figure 4

Incorrect

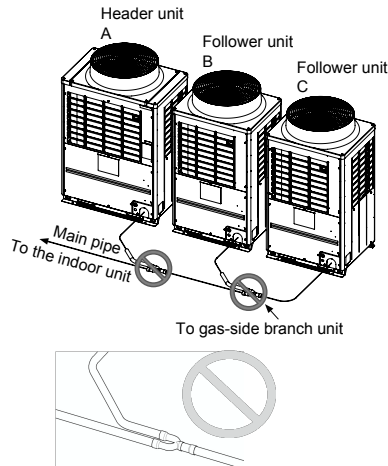

- When a Y-shaped branch unit for the gas side is attached, attach it parallel with the ground (Do not exceed ± 15 degrees.). Regarding a T-shape branch joints for the liquid side, there is no restriction for its angle.

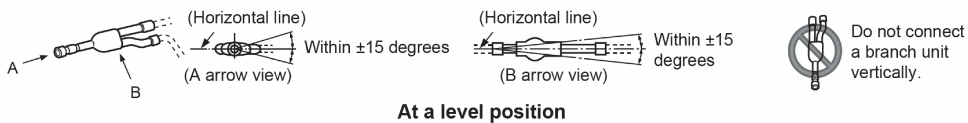

7 Refrigerant piping

⚠ WARNING

- If the refrigerant gas leaks during installation, ventilate the room.
- After installation, check that the refrigerant gas does not leak.
If the refrigerant gas leaks into the room and comes into contact with fire such as a fan heater, stove, or kitchen range, noxious gas may be generated.

■ Connection of refrigerant pipe

- The service valves are inside the outdoor unit. To access them, remove the front panel and the piping/wiring panel. (M5: 9 pcs.)
- As shown in the illustration on the right, the hooks are at the right and left sides of the front panel. Lift up and remove the front panel.
- Pipes can be drawn out forward or downward from the outdoor unit.
- To draw out the pipe forward, draw it out to the outside via the piping/wiring panel, and leave a space of 19.7" (500mm) or more from the main pipe connecting the outdoor unit with the indoor unit, considering service work or other work on the unit. (For replacing the compressor, 19.7" (500mm) or more space is required.)
- To draw out the pipe downward, remove the knockouts on the base plate of the outdoor unit, draw the pipes out of the outdoor unit, and perform piping on the right/left or rear side. Downward length of the balance pipe should be 16.4 ft (5m) or less.

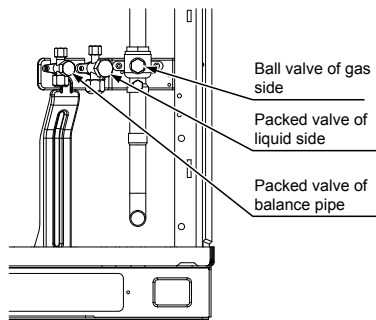
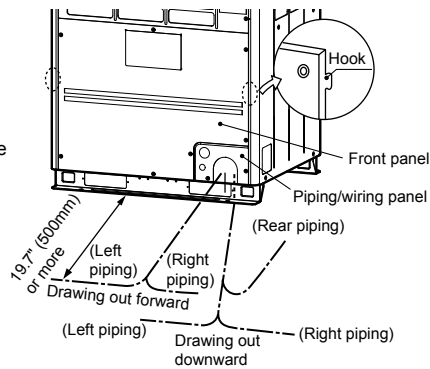

(MAP072, MAP096, MAP120)

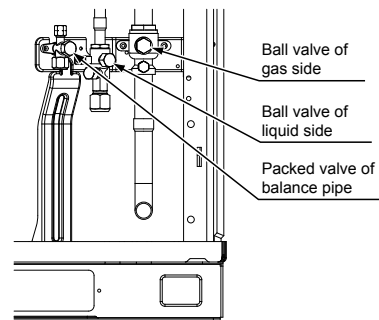

(MAP144, MAP168)

REQUIREMENT

- For a brazing work of the refrigerant pipes, be sure to use nitrogen gas in order to prevent oxidation of the inside of the pipes; otherwise clogging of the refrigerating cycle due to oxidized scale may occur.
- Use clean and new pipes for the refrigerant pipes and perform piping work so that water or dust does not contaminate the refrigerant.
- Use two spanners to loosen or tighten the flare nut. If a single spanner is used, the required level of tightening cannot be obtained. Tighten the flare nut to the specified torque. (If it is hard to loosen or tighten the flare nut of the balance pipe or packed valve of the liquid side with two spanners, loosen or tighten the flare nut while holding the valve mounting plate with a spanner.)

Unit: ft·lbs (N·m)	
Outer dia. of copper pipe	Tightening torque
Ø1/4 (6.4 mm)	10 to 13 (14 to 18)
Ø3/8 (9.5 mm)	24 to 31 (33 to 42)
Ø1/2 (12.7 mm)	37 to 46 (50 to 62)
Ø5/8 (15.9 mm)	50 to 60 (68 to 82)
Ø7/8 (19.1 mm)	74 to 88 (100 to 120)

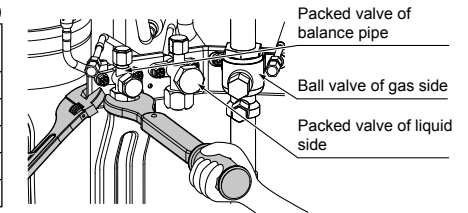

Pipe connection method of valve at the gas side (Example)

Model	Pipe diameter	Draw-out forward	Draw-out downward
MAP072 MAP096	Ø7/8	<p>Cut the L-shaped pipe at the horizontal straight section, then braze the supplied attachment pipe and the socket and pipe procured locally.</p>	<p>Cut the L-shaped pipe at the vertical straight section, then braze the supplied attachment pipe and the socket and pipe procured locally.</p>
MAP120	Ø1-1/8	<p>Cut the L-shaped pipe at the horizontal straight section, then braze the supplied attachment pipe and the socket and pipe procured locally.</p>	<p>Cut the L-shaped pipe at the vertical straight section, then braze the supplied attachment pipe and the socket and pipe procured locally.</p>

Model	Pipe diameter	Draw-out forward	Draw-out downward
MAP144 MAP168	Ø1-1/8	<p>Cut the L-shaped pipe at the horizontal straight section, then braze the supplied attachment pipe, and the socket, elbow and pipe procured locally.</p>	<p>Cut the L-shape pipe at the vertical straight section, then braze the supplied attachment pipe, and the socket and pipe procured locally.</p>

Extruding margin of copper pipe with flare machining: B (Unit: in (mm))

Copper pipe outer dia.	When using R410A tool	When using conventional tool
3/8" (9.5)	0 - 0.02" (0 - 0.5)	0.04" - 0.06" (1.0 - 1.5)
1/2" (12.7)		
5/8" (15.9)		
7/8" (19.1)		

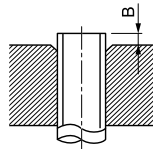

Extruding margin of copper pipe with flare tools: A (Unit: in (mm))

Copper pipe outer dia.	A ⁺⁰ / _{-0.02" (-0.4)}
3/8" (9.5)	0.52" (13.2)
1/2" (12.7)	0.65" (16.6)
5/8" (15.9)	0.78" (19.7)
7/8" (19.1)	0.94" (24.0)

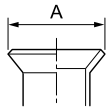

* When using the conventional flare tool, to connect R410A pipes with flaring, make a margin approx. 0.02" (0.5 mm) longer than that of an R22 pipe so that the flare size matches the one specified. It is convenient to use a copper pipe gauge for size adjustment of the extruding margin.

CAUTION

Wrap the ball valve in a wet cloth to keep it cool and prevent the heat from the torch from damaging it when connecting the pipe to the ball valve on the gas line.

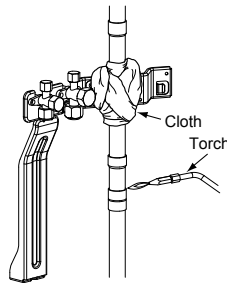

Coupling size of brazed pipe

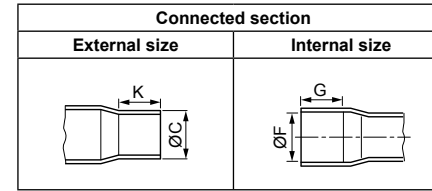

Standard outer dia. of connected copper pipe	Connected section										Min. thickness of coupling		
	External size		Internal size		Min. depth of insertion		Oval value						
	Standard outer dia. (Allowable difference)				K	G							
	C		F										
in	mm	in	mm	in	mm	in	mm	in	mm	in	mm		
Ø1/4	6.35	1/4"(±0.0012)	6.35(±0.03)	0.25" ^(+0.0016) / _(-0.0008)	6.45 ^(+0.04) / _(-0.02)	0.28	7	0.24	6	0.0024" or less	0.06 or less	0.020"	0.50
Ø3/8	9.52	3/8"(±0.0012)	9.52(±0.03)	0.38" ^(+0.0016) / _(-0.0008)	9.62 ^(+0.04) / _(-0.02)	0.31	8	0.28	7	0.0031" or less	0.08 or less	0.024"	0.60
Ø1/2	12.7	1/2"(±0.0012)	12.70(±0.03)	0.5" ^(+0.0016) / _(-0.0008)	12.81 ^(+0.04) / _(-0.02)	0.35	9	0.31	8	0.0039" or less	0.10 or less	0.028"	0.70
Ø5/8	15.88	5/8"(±0.0012)	15.88(±0.03)	0.63" ^(+0.0016) / _(-0.0008)	16.00 ^(+0.04) / _(-0.02)	0.35	9	0.31	8	0.0051" or less	0.13 or less	0.031"	0.80
Ø3/4	19.05	3/4"(±0.0012)	19.05(±0.03)	0.76" ^(+0.0012) / _(-0.0012)	19.19 ^(+0.03) / _(-0.03)	0.43	11	0.39	10	0.0059" or less	0.15 or less	0.031"	0.80
Ø7/8	22.2	7/8"(±0.0012)	22.22(±0.03)	0.88" ^(+0.0012) / _(-0.0012)	23.36 ^(+0.03) / _(-0.03)	0.43	11	0.39	10	0.0063" or less	0.16 or less	0.032"	0.82
Ø1-1/8	28.58	1-1/8"(±0.0012)	28.58(±0.04)	1.13" ^(+0.0024) / _(-0.0024)	28.75 ^(+0.06) / _(-0.02)	0.51	13	0.47	12	0.0079" or less	0.20 or less	0.039"	1.00
Ø1-3/8	34.92	1-3/8"(±0.0012)	34.90(±0.04)	1.38" ^(+0.0016) / _(-0.0016)	35.11 ^(+0.04) / _(-0.04)	0.55	14	0.51	13	0.0098" or less	0.25 or less	0.047"	1.20
Ø1-5/8	41.28	1-5/8"(±0.0012)	41.28(±0.05)	1.63" ^(+0.0031) / _(-0.0031)	42.28 ^(+0.08) / _(-0.08)	0.59	15	0.55	14	0.0110" or less	0.28 or less	0.053"	1.35

Selection of pipe size

Capacity code of indoor and outdoor units

Selection of pipe material

- For the indoor unit, the capacity code is decided at each capacity type. (Table 1)
- The capacity codes of the outdoor units are decided at each capacity type. The maximum number of connectable indoor units and the total value of capacity codes of the indoor units are also decided. (Table 2)

NOTE

Compared with the capacity code of the outdoor unit, the total value of capacity codes of the connectable indoor units differs based on the height difference between the indoor units.

If MMU-AP0072H2UL-1 or MMU-AP0122H2UL is included in the system, total indoor capacity code must be between 80% and 100% of outdoor unit capacity.

When the height difference between the indoor units is 49 ft (15 m) or less
Total indoor capacity code must be between 50% and 135% of the capacity of the outdoor unit.

When the height difference between the indoor units is over 49 ft (15 m)
Total indoor capacity code must be between 50% and 105% of the capacity of the outdoor unit.

* If the system configure only the limited indoor unit type and limited number of connection indoor unit, total indoor capacity code up to 150% of the outdoor capacity code is available when the height difference between the indoor units is 49 ft (15 m) or less. For more information, please refer to the engineering data book.

* Permanent operation below 80 % is not recommended.

Table 1

Indoor unit capacity type	Indoor capacity code (Equivalent to capacity)
007 type	7.5
009 type	9.5
012 type	12
015 type	15.4
018 type	18
021 type	21
024 type	24
027 type	27
030 type	30
036 type	36
042 type	42
048 type	48
054 type	54
072 type	72
096 type	96

* For combination of the outdoor units, refer to "Combination of outdoor units".

Table 2

Outdoor unit capacity type	Outdoor unit capacity code	Maximum number of indoor units	
		Height difference between indoor units	
		49 ft (15 m) or less	Over 49 ft (15 m)
072 type	72	12	10
096 type	96	16	13
120 type	120	21	16
144 type	144	25	19
168 type	168	30	23
192 type	192	34	26
216 type	216	38	29
240 type	240	42	32
264 type	264	46	36
288 type	288	50	39
312 type	312	55	43
336 type	336	60	47
360 type	360	63	49
384 type	384	64	52
408 type	408	64	55
432 type	432	64	59
456 type	456	64	63

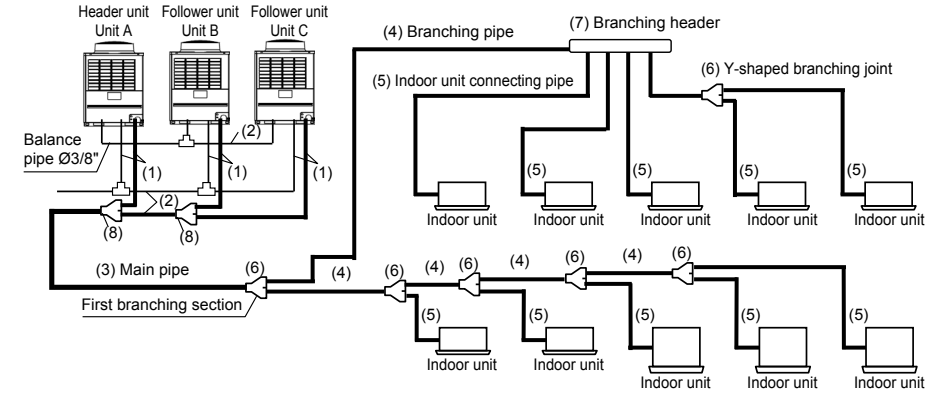

Unit: in

No.	Piping parts	Name	Selection of pipe size	Remarks																								
(1)	Outdoor unit ↓ Outdoor unit connection piping kit	Outdoor unit connecting pipe	(1) Outdoor unit connecting pipe (Table 1) <table border="1"> <thead> <tr> <th>Outdoor unit capacity type</th> <th>Gas side</th> <th>Liquid side</th> </tr> </thead> <tbody> <tr> <td>072 type, 096 type</td> <td>Ø7/8"</td> <td>Ø1/2"</td> </tr> <tr> <td>120 type</td> <td>Ø1-1/8"</td> <td>Ø1/2"</td> </tr> <tr> <td>144 type, 168 type</td> <td>Ø1-1/8"</td> <td>Ø5/8"</td> </tr> </tbody> </table>	Outdoor unit capacity type	Gas side	Liquid side	072 type, 096 type	Ø7/8"	Ø1/2"	120 type	Ø1-1/8"	Ø1/2"	144 type, 168 type	Ø1-1/8"	Ø5/8"	Same as connecting pipe size of the outdoor unit.												
Outdoor unit capacity type	Gas side	Liquid side																										
072 type, 096 type	Ø7/8"	Ø1/2"																										
120 type	Ø1-1/8"	Ø1/2"																										
144 type, 168 type	Ø1-1/8"	Ø5/8"																										
(2)	Between Outdoor unit connection piping kits	Main connecting piping between outdoor units	(2) Main connecting pipe between outdoor units (Table 2) <table border="1"> <thead> <tr> <th>Total capacity code of the total outdoor units on the downstream side (*1)</th> <th>Gas side</th> <th>Liquid side</th> <th>Balance pipe</th> </tr> </thead> <tbody> <tr> <td>240 or more</td> <td>Ø1-3/8"</td> <td>Ø3/4"</td> <td>Ø3/8"</td> </tr> </tbody> </table>	Total capacity code of the total outdoor units on the downstream side (*1)	Gas side	Liquid side	Balance pipe	240 or more	Ø1-3/8"	Ø3/4"	Ø3/8"	The start point of the downstream side is the main connecting pipe between outdoor units. The total capacity code of the outdoor units on the downstream side. Example: The total capacity code of Unit B and Unit C																
Total capacity code of the total outdoor units on the downstream side (*1)	Gas side	Liquid side	Balance pipe																									
240 or more	Ø1-3/8"	Ø3/4"	Ø3/8"																									
(3)	Outdoor unit connection piping kit of header unit ↓ First branching section	Main piping	(3) Main pipe (Table 3) <table border="1"> <thead> <tr> <th>Total capacity code of all outdoor units (*1)</th> <th>Gas side</th> <th>Liquid side</th> </tr> </thead> <tbody> <tr> <td>72 to below 120</td> <td>Ø7/8"</td> <td>Ø1/2"</td> </tr> <tr> <td>120 to below 144</td> <td>Ø1-1/8"</td> <td>Ø1/2"</td> </tr> <tr> <td>144 to below 216</td> <td>Ø1-1/8"</td> <td>Ø5/8"</td> </tr> <tr> <td>216 to below 336</td> <td>Ø1-3/8"</td> <td>Ø3/4"</td> </tr> <tr> <td>336 or more</td> <td>Ø1-5/8"</td> <td>Ø7/8"</td> </tr> </tbody> </table>	Total capacity code of all outdoor units (*1)	Gas side	Liquid side	72 to below 120	Ø7/8"	Ø1/2"	120 to below 144	Ø1-1/8"	Ø1/2"	144 to below 216	Ø1-1/8"	Ø5/8"	216 to below 336	Ø1-3/8"	Ø3/4"	336 or more	Ø1-5/8"	Ø7/8"	Pipe size differs based on all capacity code value of outdoor unit.						
Total capacity code of all outdoor units (*1)	Gas side	Liquid side																										
72 to below 120	Ø7/8"	Ø1/2"																										
120 to below 144	Ø1-1/8"	Ø1/2"																										
144 to below 216	Ø1-1/8"	Ø5/8"																										
216 to below 336	Ø1-3/8"	Ø3/4"																										
336 or more	Ø1-5/8"	Ø7/8"																										
(4)	Branching section ↓ Branching section	Branching pipe	(4) Branching pipe (Table 4) <table border="1"> <thead> <tr> <th>Total capacity code of the indoor units on the downstream side (*1) (*4)</th> <th>Gas side</th> <th>Liquid side</th> </tr> </thead> <tbody> <tr> <td>Below 23</td> <td>Ø1/2"</td> <td>Ø3/8"</td> </tr> <tr> <td>23 to below 61</td> <td>Ø5/8"</td> <td>Ø3/8"</td> </tr> <tr> <td>61 to below 116</td> <td>Ø7/8"</td> <td>Ø1/2"</td> </tr> <tr> <td>116 to below 192</td> <td>Ø1-1/8"</td> <td>Ø5/8"</td> </tr> <tr> <td>192 to below 213</td> <td>Ø1-1/8"</td> <td>Ø3/4"</td> </tr> <tr> <td>213 to below 336</td> <td>Ø1-3/8"</td> <td>Ø3/4"</td> </tr> <tr> <td>336 or more</td> <td>Ø1-5/8"</td> <td>Ø7/8"</td> </tr> </tbody> </table>	Total capacity code of the indoor units on the downstream side (*1) (*4)	Gas side	Liquid side	Below 23	Ø1/2"	Ø3/8"	23 to below 61	Ø5/8"	Ø3/8"	61 to below 116	Ø7/8"	Ø1/2"	116 to below 192	Ø1-1/8"	Ø5/8"	192 to below 213	Ø1-1/8"	Ø3/4"	213 to below 336	Ø1-3/8"	Ø3/4"	336 or more	Ø1-5/8"	Ø7/8"	Pipe size differs based on the total capacity code value of indoor units at the downstream side. If the total capacity code value of indoor units exceeds that of the outdoor units, apply the capacity code of the outdoor units.
Total capacity code of the indoor units on the downstream side (*1) (*4)	Gas side	Liquid side																										
Below 23	Ø1/2"	Ø3/8"																										
23 to below 61	Ø5/8"	Ø3/8"																										
61 to below 116	Ø7/8"	Ø1/2"																										
116 to below 192	Ø1-1/8"	Ø5/8"																										
192 to below 213	Ø1-1/8"	Ø3/4"																										
213 to below 336	Ø1-3/8"	Ø3/4"																										
336 or more	Ø1-5/8"	Ø7/8"																										

EN

No.	Piping parts	Name	Selection of pipe size	Remarks			
(5)	Branching section ↓ Indoor unit	Indoor unit connecting pipe	(5) Indoor unit connection pipe (Table 5)				
			Indoor unit capacity code				
			7.5 to 12	Pipe length (Actual length)	49 ft length	Ø3/8"	Ø1/4"
					Over 49 ft	Ø1/2"	Ø1/4"
						Ø1/2"	Ø1/4"
			21 to 54	Ø5/8"	Ø3/8"		
			72 to 96	Ø7/8"	Ø1/2"		
(6)	Branching section	Y-shaped branching joint	(6) Y-shaped branching joint (Table 6)				
			Total capacity code of the indoor units on the downstream side from Y-shaped branching joint (*2) (*3) (*6)		Model name		
			Below 61		RBM-BY 55UL		
			61 to below 134		RBM-BY105UL		
			134 to below 239		RBM-BY205UL		
239 or more		RBM-BY305UL					
(7)	Branching section	Branching header	(7) Branching header (Table 7)				
			Total capacity code of the indoor units on the downstream side from branching header (*2) (*3) (*5) (*6)		Model name		
			Below 134		RBM-HY1043UL		
			134 to below 239		RBM-HY2043UL		
			Below 134		RBM-HY1083UL		
134 to below 239		RBM-HY2083UL					
(8)	Branching section	Outdoor unit connection piping kit (For linking of outdoor units)	(8) Outdoor unit connection piping kit (Table 8)				
			Total capacity code of the total outdoor units on the downstream side (*1)		Model name		
			Below 247	RBM-BT14UL			
	247 or more	RBM-BT24UL					

CAUTION

Please use the appropriate pipe when the pipe size is Ø3/4 or more. (Table 9)

Outer diameter		Minimum wallthickness		Temper	
				Soft	Hard, Semi hard
Inch	mm	Inch	mm	OK	OK
Ø1/4"	6.35	0.03	0.80	OK	OK
Ø3/8"	9.52	0.03	0.80	OK	OK
Ø1/2"	12.7	0.04	1.00	OK	OK
Ø5/8"	15.88	0.04	1.00	OK	OK
Ø3/4"	19.05	0.04	1.00	NG	OK
Ø7/8"	22.2	0.04	1.00	NG	OK
Ø1-1/8"	28.58	0.04	1.00	NG	OK
Ø1-3/8"	34.92	0.05	1.20	NG	OK
Ø1-5/8"	41.28	0.06	1.40	NG	OK

- *1: Code is determined according to the capacity type.
- *2: When using a branching joint for the first branch, select according to capacity code of the outdoor unit.
- *3: For 1 line after branching header indoor units with a maximum capacity code of 57 in total can be connected.
- *4: If the piping size becomes over main piping size, select the size same as main piping.
- *5: When the first branch is a header with the outdoor total capacity of 120 to 247, apply the model RBM-HY2043UL (4-branch) or RBM-HY2083UL (8-branch) regardless of the total capacity codes of the down-stream indoor units.
- *6: When the sum of capacity code of indoor units exceeds the capacity code of outdoor units, select according to capacity code of the outdoor units.

Allowable length of refrigerant pipes and allowable height difference between units

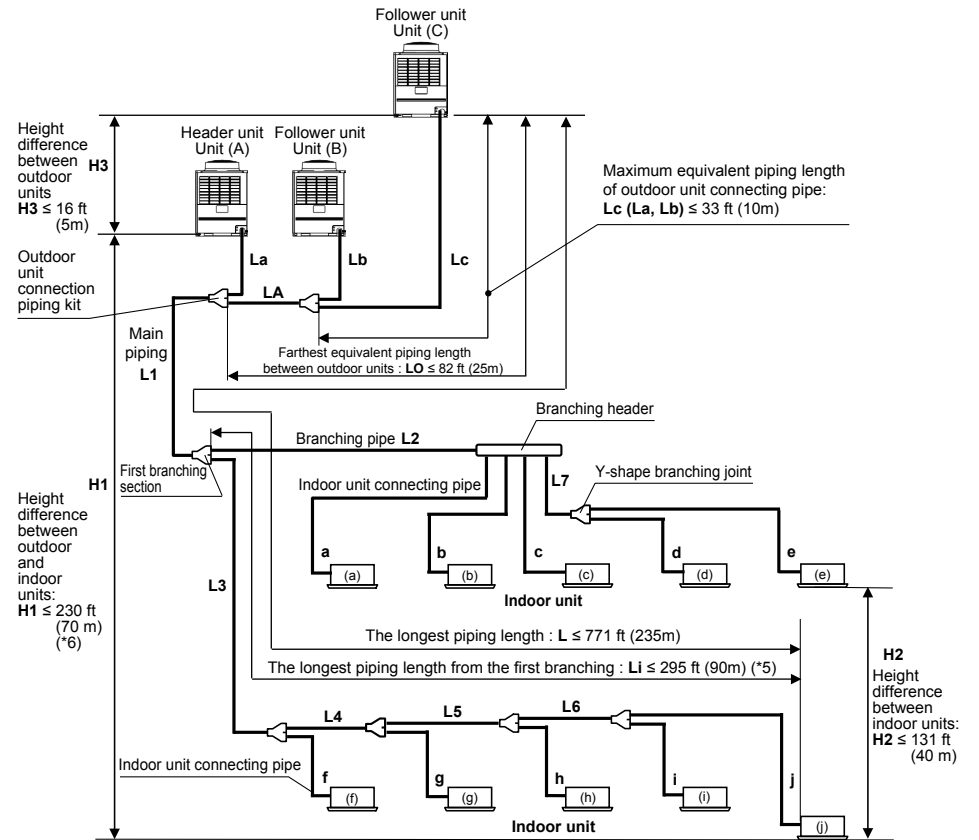

◆ System restrictions

Max. No. of combined outdoor units	3 units	
Max. capacity of combined outdoor units	38 ton	
Max. No. of combined indoor units	64 units	
Max. capacity of combined indoor units	H2 ≤ 49 ft (15m)	135% of outdoor units' capacity 150% of indoor units' capacity (*1)
	H2 > 49 ft (15m)	105% of outdoor units' capacity

(*1) : If the system configure only the limited indoor unit type and limited number of connection indoor unit, total indoor capacity code up to 150% of the outdoor capacity code is available when the height difference between the indoor units is 49 ft (15m) or less.

For more information, please refer to the engineering data book.

◆ Cautions for installation

- Set the outdoor unit first connected to the branching pipe to the indoor units as the header unit.
- Install the outdoor units in order of their capacity codes : (A) header unit ≥ (B) ≥ (C)
- Y-shaped branching joint must be installed horizontally.
- When piping to outdoor units using outdoor unit connection piping kits, intersect the pipes to the outdoor unit and those to indoor units at a right angle as shown in figure 1 on "6. Installation of the outdoor unit". Do not connect them as in figure 2 on "6. Installation of the outdoor unit".

◆ Allowable length/height difference of refrigerant piping

Pipe length	Total extension of pipe (Liquid pipe)	Actual length	Allowable value		Pipes	
			ft	m		
Pipe length	Actual length		3281 (*3)	1000	$La + Lb + Lc + LA + L1 + L2 + L3 + L4 + L5 + L6 + L7 + a + b + c + d + e + f + g + h + i + j$	
	Farthest piping length L (*2)	Equivalent length	771	235	$Lc + LA + L1 + L3 + L4 + L5 + L6 + j$	
		Actual length	623	190		
	Main piping length	Equivalent length	Below 432 kbtu/h	394	120	L1
			432 kBTu/h or more	230 (*4)	70 (*4)	
		Actual length	Below 432 kbtu/h	328	100	
			432 kBTu/h or more	164 (*4)	50 (*4)	
	Farthest equivalent piping length from the first branching section L1 (*2)	Equivalent length	H1 > 9.8ft (3m)	213 (*5)	65 (*5)	L3 + L4 + L5 + L6 + L7 + j
	Farthest equivalent piping length between outdoor units LO	Equivalent length	H1 ≤ 9.8ft (3m)	295	90	
	Maximum equivalent piping length of outdoor unit connecting pipe	Equivalent length		33	10	La, Lb, Lc
Maximum actual length of pipes connected to indoor units	Actual length		98	30	a, b, c, d, e, f, g, h, i, j	
Maximum equivalent length between branching sections	Equivalent length		164	50	L2, L3, L4, L5, L6, L7	
Height difference	Height between outdoor and indoor units H1	H2 > 9.8ft (3m)	Upper outdoor units	164 (*6)	50 (*6)	—
		Lower outdoor units	98 (*7)	30 (*7)	—	
	H2 ≤ 9.8ft (3m)	Upper outdoor units	230	70	—	
		Lower outdoor units	131	40	—	
Height between indoor units H2			131	40	—	
Height between outdoor units H3			16	5	—	

(*2) : Farthest outdoor unit from the first branching section is the follower unit (C). Farthest indoor unit from the first branching section is the indoor unit (j).

(*3) : Total refrigerant amount in the system is restricted according to capacity type. Refer to the table below.

(*4) : If the max. combined outdoor unit capacity is 432 kBTu/h or more, than max. equivalent length is 230 ft or less (Actual length is 164 ft or less).

(*5) : If the height difference (H1) between outdoor and indoor unit exceeds 9.8 ft, set 213 ft or less.

(*6) : If the height difference (H2) between indoor units exceeds 9.8 ft, set 164 ft or less.

(*7) : If the height difference (H2) between indoor units exceeds 9.8 ft, set 98 ft or less.

Standard model	Capacity type	072	096	120	144	168	192	216	240	264	288	312	336	360	384	408	432	456	
	Applicable total refrigerant amount (lbs)		88	107	110	150	153	204	207	254	257	287	290	308	308	308	308	308	308
Space saving model	Capacity type	192	240	288	408														
	Applicable total refrigerant amount (lbs)	177	210	260	308														

■ Airtightness test

After the refrigerant piping has been finished, execute an airtight test.

For an airtight test, connect a nitrogen gas canister as shown in the figure on this page and apply pressure.

- Be sure to apply pressure from the service ports of the packed valves (or ball valves) at the liquid side, gas side and balance pipe side.
- An airtight test can only be performed at the service ports at the liquid side, gas side and balance pipe side on header unit.
- Close the valves fully at the gas side, liquid side and balance pipe side. As there is a possibility that the nitrogen gas will enter into the cycle of outdoor units, re-tighten the valve rods at the liquid side and balance pipe side before applying pressure.
- (When using MAP096, MAP120, MAP144 or MAP168, you do not have to re-tighten the liquid side valve rod as their valves at the liquid side are ball valves.)
- For each refrigerant line, apply pressure gradually in steps at the liquid side, gas side and balance pipe side. **Be sure to apply pressure at the gas side, liquid side, and balance pipe side.**

⚠ WARNING

Never use oxygen, flammable gases, or noxious gases in an airtight test.

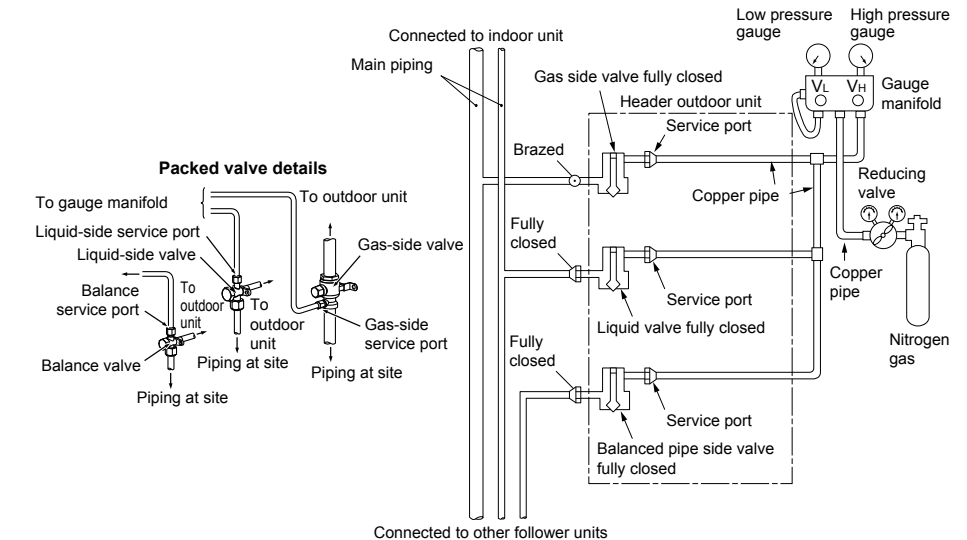

Able to detect a serious leakage

1. Apply pressure 43.5 psi (0.3 MPa) for 5 minutes or more.
2. Apply pressure 217.5 psi (1.5 MPa) for 5 minutes or more.

Available to detect slow leakage

3. Apply pressure 601 psi (4.15 MPa) for approx. 24 hours.
- If there is no pressure decrease after 24 hours, the test is passed.

NOTE

However, if the environmental temperature changes from the moment of applying pressure to 24 hours after that, the pressure will change by about 1.45 psi (0.01 MPa) per 1.8 °F. Consider the pressure change when checking the test result.

REQUIREMENT

When pressure decrease is detected in steps 1-3, check the leakage at the connecting points. Check the leakage using a foaming agent or other measures and seal the leak with re-brazing, flare retightening or other methods. After sealing, execute an airtight test again.

■ Vacuum drying

- Be sure to perform vacuuming from both liquid and gas sides.
- Be sure to use a vacuum pump equipped with the counter-flow prevention function so that oil in the pump will not flow back into piping for air conditioners. (If oil in the vacuum pump enters in the air conditioner with R410A refrigerant, a problem may be caused in the refrigerating cycle.)

After finishing the airtight test and discharging nitrogen gas, connect the gauge manifold to the service ports of the liquid side, gas side, and balance pipe side and connect a vacuum pump as shown in the figure below. Be sure to perform vacuuming for the liquid, gas, and balance pipe sides.

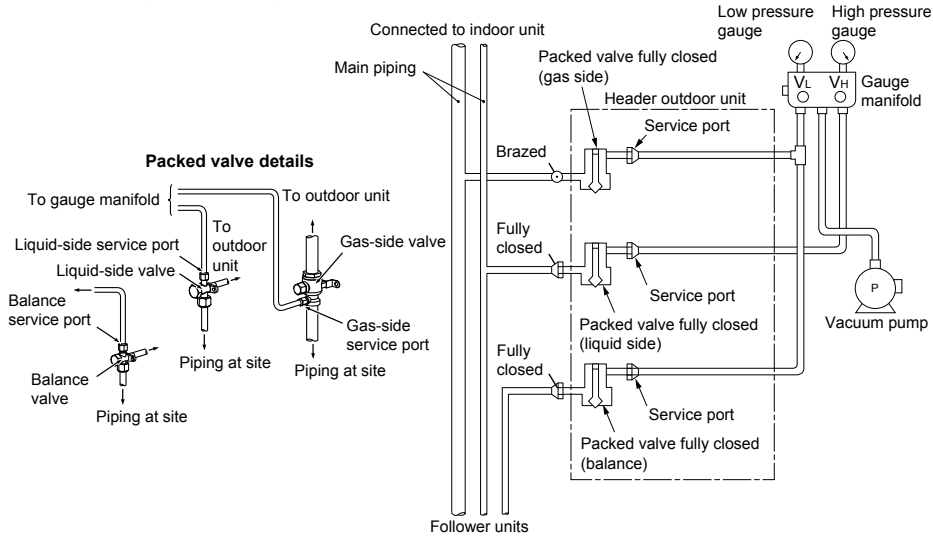

- Use a vacuum pump with a high vacuuming degree [14.6 psi (5Torr, -755mmHg)] and large exhaust gas amount (40L/minute or larger).
- Perform vacuuming for 2 or 3 hours, though the time differs depending on the pipe length. Check that all the packed valves at the liquid side, gas side, and balance pipe side are fully closed.
- If the pressure does not reach 14.6 psi or less, continue vacuuming for 1 hour or more. If the pressure does not reach 14.6 psi after 3 hours of vacuuming, stop vacuuming and check for air leakage.
- If the pressure reaches 14.6 psi or less after vacuuming for 2 hours or more, close the valves VL and VH on the gauge manifold fully and stop the vacuum pump. Leave it as it is for 1 hour to confirm that the vacuuming degree does not change. If the degree of vacuum loss is large, moisture may remain in the pipes. In that case, inject dry nitrogen gas and apply pressure to 0.05MPa and perform vacuuming again.
- After finishing the above procedure of vacuuming, exchange the vacuum pump with a refrigerant canister and advance to the additional charging of refrigerant.

■ Adding refrigerant

After finishing vacuuming, exchange the vacuum pump with a refrigerant canister and start additional charging of refrigerant.

1. Refrigerant charge amount at shipment from the factory does not include the refrigerant for pipes at the local site. For refrigerant to be charged in pipes at the local site, calculate the amount and charge it additionally.

Model name	Refrigerant amount charged in factory
MMY-MAP	25.4 lbs
0726HT6P-UL	
0966HT6P-UL	
1206HT6P-UL	
1446HT6P-UL	
1686HT6P-UL	

2. Additional refrigerant charge, please calculate from the calculation of additional refrigerant charge amount.

■ Calculation of additional refrigerant charge amount

$$\text{Additional refrigerant charge amount (lbs)} = [1] + [2] + [3]$$

- [1]. Compensation by capacity of outdoor unit (Table1)
- [2]. Additional refrigerant charge amount indoor unit (Table2)
- [3]. (Actual length of liquid pipe × Additional refrigerant charge amount per liquid pipe 1 ft (Table3)) × 1.2

NOTE

If the additional refrigerant amount indicates minus as the result of calculation, use the air conditioner without additional refrigerant.

(Table1) Compensation by capacity of outdoor unit

Outdoor unit capacity type	Model name (Standard Model)	Compensation by capacity type outdoor unit (lbs)
072 type	MMY-MAP0726HT6P-UL	-7.7
096 type	MMY-MAP0966HT6P-UL	-2.2
120 type	MMY-MAP1206HT6P-UL	-2.2
144 type	MMY-MAP1446HT6P-UL	7.7
168 type	MMY-MAP1686HT6P-UL	7.7
192 type	MMY-AP1926HT6P-UL	-6.6
216 type	MMY-AP2166HT6P-UL	-6.6
240 type	MMY-AP2406HT6P-UL	0.0
264 type	MMY-AP2646HT6P-UL	0.0
288 type	MMY-AP2886HT6P-UL	6.6
312 type	MMY-AP3126HT6P-UL	6.6
336 type	MMY-AP3366HT6P-UL	6.6
360 type	MMY-AP3606HT6P-UL	-9.9
384 type	MMY-AP3846HT6P-UL	-3.3
408 type	MMY-AP4086HT6P-UL	5.5
432 type	MMY-AP4326HT6P-UL	5.5
456 type	MMY-AP4566HT6P-UL	5.5

Outdoor unit capacity type	Model name (Space Saving Model)	Compensation by capacity type outdoor unit (lbs)
192 type	MMY-AP192S6HT6P-UL	-11.0
240 type	MMY-AP240S6HT6P-UL	-6.6
288 type	MMY-AP288S6HT6P-UL	0.0
408 type	MMY-AP408S6HT6P-UL	-3.3

(Table2) Additional refrigerant charge amount indoor unit

Standard indoor unit	lbs/kBtu/h	0.095
Fresh air intake indoor unit	lbs/kBtu/h	0.046
4-Way cassette type	MMU-AP0072H2UL-1 MMU-AP0122H2UL	lbs/kBtu/h 0.181

(Table3) Actual length of liquid pipe × Additional refrigerant charge amount per liquid pipe 1 ft

Liquid pipe outer diameter	(in)	Ø1/4"	Ø3/8"	Ø1/2"	Ø5/8"	Ø3/4"	Ø7/8"
Additional refrigerant amount	lbs/ft	0.017	0.037	0.071	0.108	0.168	0.235

Example:
120 type (MMY-MAP120HT6P-UL)

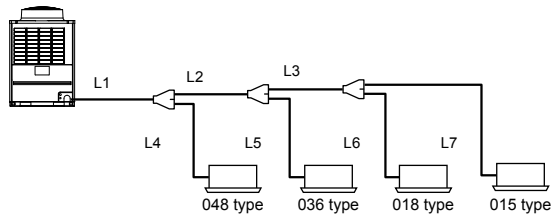

Pipe	Liquid pipe size	Actual Piping length
L1	Ø1/2"	30 ft
L2	Ø1/2"	15 ft
L3	Ø3/8"	10 ft
L4	Ø3/8"	10 ft
L5	Ø3/8"	15 ft
L6	Ø1/4"	10 ft
L7	Ø1/4"	10 ft

Additional refrigerant charge amount(lbs) = [1] + [2] + [3]

$$= -2.2 \text{ lbs} + 11.15 \text{ lbs} + 5.13 \text{ lbs}$$

$$= -2.2 \text{ lbs} + 11.15 \text{ lbs} + 5.13 \text{ lbs}$$

$$= 14.08 \text{ lbs}$$

[1]. Compensation by capacity of outdoor unit (**Table1**)

$$= \text{Compensation by 120 type}$$

$$= -2.2 \text{ lbs}$$

[2]. Additional refrigerant charge amount indoor unit (**Table2**)

$$= (048 \text{ type capacity code} \times 0.095) + (036 \text{ type capacity code} \times 0.095) + (018 \text{ type capacity code} \times 0.095) + (015 \text{ type capacity code} \times 0.095)$$

$$= (48 \times 0.095) + (36 \times 0.095) + (18 \times 0.095) + (15.4 \times 0.095)$$

$$= 11.15 \text{ lbs}$$

[3]. (Actual length of liquid pipe × Additional refrigerant charge amount per liquid pipe 1 ft (**Table3**)) × 1.2

$$= (Lx \times 0.017 \text{ lbs/ft} + Ly \times 0.037 \text{ lbs/ft} + Lz \times 0.071 \text{ lbs/ft}) \times 1.2$$

$$= ((L6+L7) \times 0.017 \text{ lbs/ft} + (L3+L4+L5) \times 0.037 \text{ lbs/ft} + (L1+L2) \times 0.071 \text{ lbs/ft}) \times 1.2$$

$$= ((20 \text{ ft}) \times 0.017 \text{ lbs/ft} + (25 \text{ ft}) \times 0.037 \text{ lbs/ft} + (45 \text{ ft}) \times 0.071 \text{ lbs/ft}) \times 1.2$$

$$= (0.34 \text{ lbs} + 0.74 \text{ lbs} + 3.195 \text{ lbs}) \times 1.2$$

$$= (4.275 \text{ lbs}) \times 1.2$$

$$= 5.13 \text{ lbs}$$

Lx : Actual total length of liquid pipe Ø1/4" (ft)

Ly : Actual total length of liquid pipe Ø3/8" (ft)

Lz : Actual total length of liquid pipe Ø1/2" (ft)

1. All service valves on the outdoor units should remain fully closed.
2. R410A refrigerant should be added (in liquid state) at the liquid line service port on the header unit.
3. If the calculated amount of refrigerant can added to the system, the charging process is finished.
4. If the total calculated amount of refrigerant cannot be added to the system, close the valve on the refrigerant bottle, move the charging hose from the liquid line service port to the suction line service port.
5. Open the suction and liquid service valves on the header unit and start the system in cooling mode.
6. Slowly open the valve on the refrigerant bottle and carefully release liquid refrigerant into the suction service port.
7. If the total calculated charge amount is added completely to the system, the charging process is finished.

■ Full opening of the valve

Open the valves of the outdoor unit fully.

	MAP072 MAP096 MAP120	MAP144 MAP168
Liquid side	<p>Packed valve Using a 4mm-hexagonal wrench, fully open the valve rods.</p>	<p>Ball valve Using a flathead screwdriver, turn it counterclockwise by 90° until it hits the stopper. (Full open)</p> <p>Position of screwdriver slot Fully closed Fully opened</p> <p>* When opened fully, do not apply excessive torque after the screwdriver hits the stopper; otherwise a problem may be caused on the valve. (5 N·m or less)</p>
Balance pipe	<p>Balance packed valve Open the valve rods fully with a 4mm-hexagonal wrench.</p>	
Gas side	<p>Ball valve Turn it counterclockwise by 90° until it hits the stopper with a wrench. (Full open)</p>	

■ Pipe insulation

- Apply pipe insulation separately to liquid, gas, and balance lines.
- All insulation should have a minimum temperature rating of 248°F (120°C).

■ Finishing pipe work

1. After all piping and insulation is complete. Fill the remaining gap at the piping panel with silicon sealer.
2. If the piping was routed down or to the side, the remaining gap should be filled with silicon sealer.

When not using the piping cover

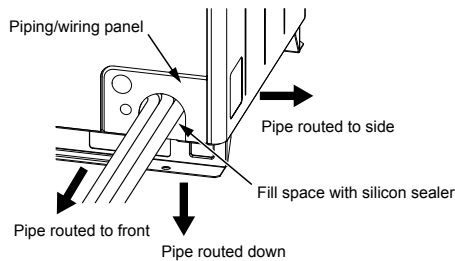

8 Electric wiring

⚠ WARNING

The equipment shall be installed in compliance with NEC and local codes.

⚠ CAUTION

- Do not connect high voltage power wires to the control terminal blocks (U1, U2, U3, U4, U5, U6);
- All field wiring insulation rating must comply with NEC and local codes.
- All wiring must be strained relieved as specified by NEC and local codes.
- Refrigerant piping and control wiring should use the same routing.
- Do not energize the indoor units until leak check and vacuuming are completed.
- For indoor unit power and control wiring see indoor unit installation instructions.

NOTE

- Use copper supply wires.
- Use UL wires rated 600V for the system interconnection wires.
- Use UL wires rated 300V for remote control wires.

■ Power supply specifications

Every outdoor unit must have a dedicated power supply.

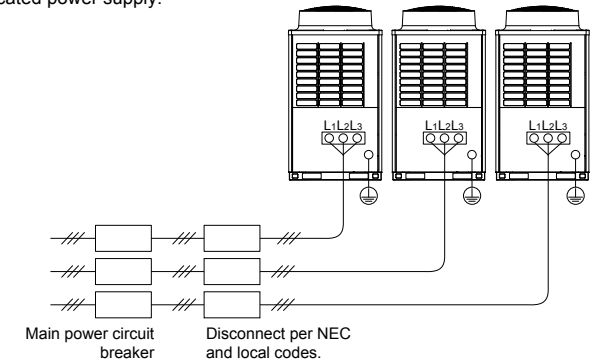

◆ Power wiring selection

MCA: Minimum Circuit Amps
MOCP: Maximum Overcurrent Protection (Amps)

Model name (Standard Model)	Power Supply		Voltage Range		MCA (A)	MOCP (A)
	Nominal Voltage	Phase and frequency	Min. (V)	Max. (V)		
MMY-MAP0726HT6P-UL	460 V	3 ~ 60 Hz	414	506	12.9	20
MMY-MAP0966HT6P-UL	460 V	3 ~ 60 Hz	414	506	20	25
MMY-MAP1206HT6P-UL	460 V	3 ~ 60 Hz	414	506	23	30
MMY-MAP1446HT6P-UL	460 V	3 ~ 60 Hz	414	506	25	35
MMY-MAP1686HT6P-UL	460 V	3 ~ 60 Hz	414	506	31	40
MMY-AP1926HT6P-UL	460 V	3 ~ 60 Hz	414	506	20 + 20	25 + 25
MMY-AP2166HT6P-UL	460 V	3 ~ 60 Hz	414	506	23 + 20	30 + 25
MMY-AP2406HT6P-UL	460 V	3 ~ 60 Hz	414	506	25 + 20	35 + 25
MMY-AP2646HT6P-UL	460 V	3 ~ 60 Hz	414	506	25 + 23	35 + 30
MMY-AP2886HT6P-UL	460 V	3 ~ 60 Hz	414	506	25 + 25	35 + 35
MMY-AP3126HT6P-UL	460 V	3 ~ 60 Hz	414	506	31 + 25	40 + 35
MMY-AP3366HT6P-UL	460 V	3 ~ 60 Hz	414	506	31 + 31	40 + 40
MMY-AP3606HT6P-UL	460 V	3 ~ 60 Hz	414	506	23 + 23 + 23	30 + 30 + 30
MMY-AP3846HT6P-UL	460 V	3 ~ 60 Hz	414	506	25 + 23 + 23	35 + 30 + 30
MMY-AP4086HT6P-UL	460 V	3 ~ 60 Hz	414	506	25 + 25 + 23	35 + 35 + 30
MMY-AP4326HT6P-UL	460 V	3 ~ 60 Hz	414	506	31 + 25 + 23	40 + 35 + 30
MMY-AP4566HT6P-UL	460 V	3 ~ 60 Hz	414	506	31 + 31 + 23	40 + 40 + 30

Model name (Space Saving Model)	Power Supply		Voltage Range		MCA (A)	MOCP (A)
	Nominal Voltage	Phase and frequency	Min. (V)	Max. (V)		
MMY-AP192S6HT6P-UL	460 V	3 ~ 60 Hz	414	506	23 + 12.9	30 + 20
MMY-AP240S6HT6P-UL	460 V	3 ~ 60 Hz	414	506	23 + 23	30 + 30
MMY-AP288S6HT6P-UL	460 V	3 ~ 60 Hz	414	506	31 + 23	40 + 30
MMY-AP408S6HT6P-UL	460 V	3 ~ 60 Hz	414	506	31 + 23 + 23	40 + 30 + 30

NOTE

Be sure to follow the above specifications when plugging in.

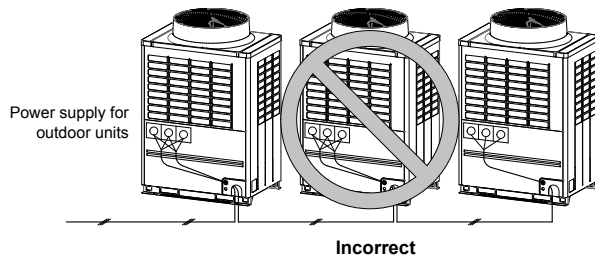

■ Specifications for control wiring

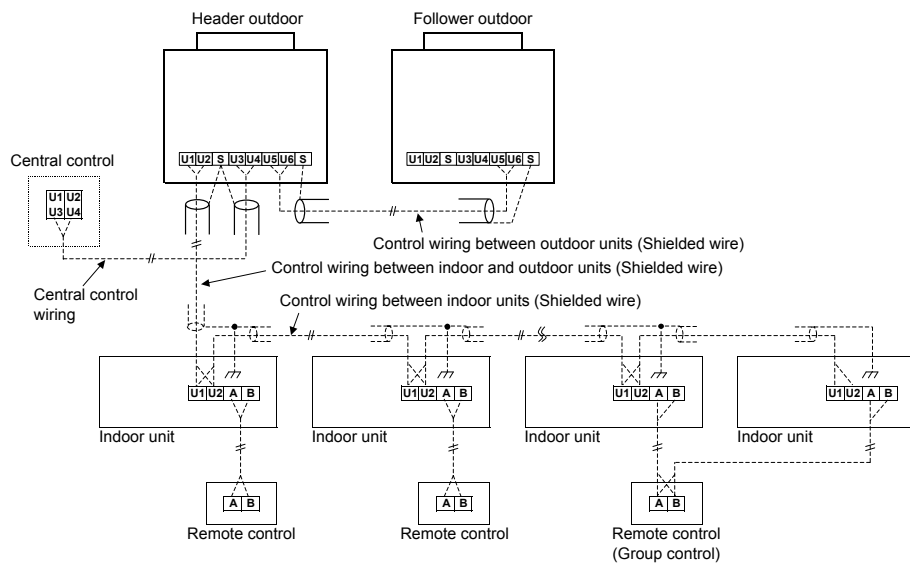

1. All system interconnecting and central control wiring should be 2 conductor shielded cable.
2. On the header unit the control wire shield and the central control wire shield should both be connected to the same ground screw in the header unit.
3. The remote control wiring can be 2 conductor un-shielded cable.
4. All system interconnecting and control wiring should be sized per table 5, 6 and 7.

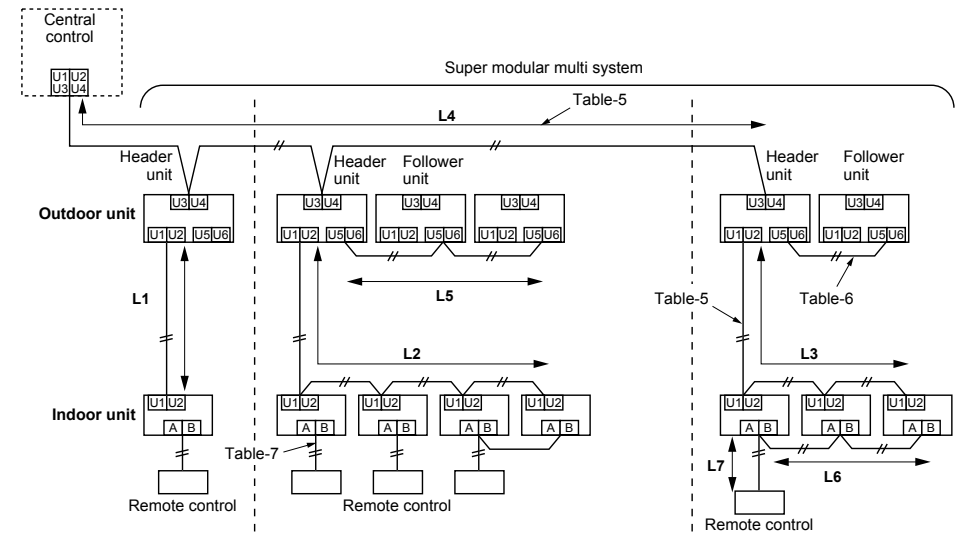

Table-5 Control wiring between indoor and outdoor units (L1, L2, L3), Central control wiring (L4)

Wiring	2-core
Type	Shielded cable
Size/Length	AWG16: Up to 3280 ft (1000 m) AWG14: Up to 6560 ft (2000 m) (*1)

(*1): Total length of control wiring length for all refrigerant circuits (L1 + L2 + L3 + L4)

Table-6 Control wiring between outdoor units (L5)

Wiring	2-core
Type	Shielded wire
Size/Length	AWG16 to AWG14 / Up to 330 ft (100 m) (L5)

Table-7 Remote control wiring (L6, L7)

Wire	2-core
Size	AWG20 to AWG14
Length	<ul style="list-style-type: none"> • Up to 1640 ft (500 m) (L6 + L7) • Up to 1310 ft (400 m) in case of wireless remote control in group control. • Up to 660 ft (200 m) total length of control wiring between indoor units (L6)

■ Connection of power supply wires and control wires

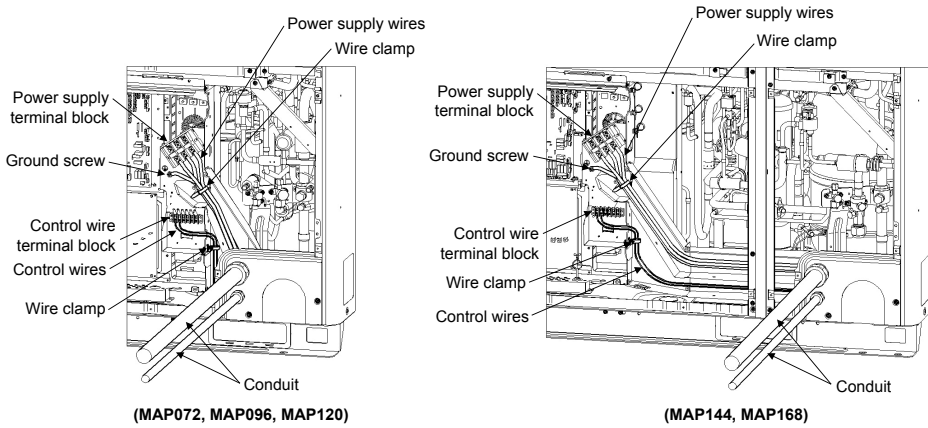

NOTE

Separate power supply wires and control wires.

◆ Power supply wire connection

1. Connect the power supply conduit to the field wiring panel.
2. Route the power supply wiring through the raceway and connect to the power supply terminal block and ground screw.
3. Use ring terminals on field power wires if required by NEC and local codes.

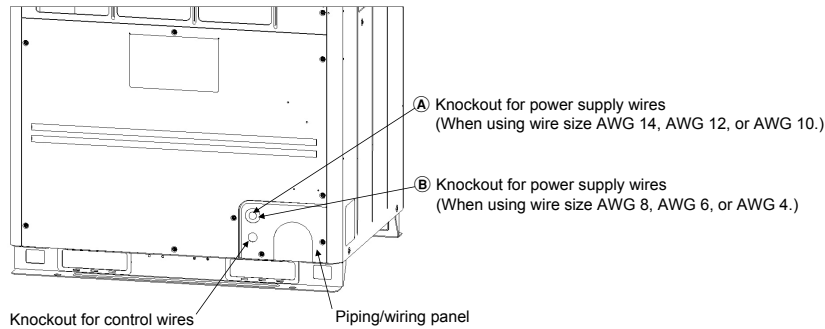

NOTE

Bundle the control wires in the cutout so that they do not get caught in the electrical control box cover.

Screw size and tightening torque

	Screw size	Tightening torque ft·lbs(N·m)
Power supply terminal	M8	4.1 to 4.8(5.5 to 6.6)
Ground screw	M8	4.1 to 4.8(5.5 to 6.6)

◆ Precautions when knocking out knockout holes

- After knocking out the hole to the other side, remove the burr, then we recommend you to paint around the edge with the repair paint to prevent the rusting.

◆ Control wire connection

1. If conduit is required for the control wiring, connect it to the field wiring panel.
2. If conduit is not required, route the control wiring directly through the field wiring panel.
3. Connect all control wiring to the system interconnecting terminal block and connect the shield to the ground screw.

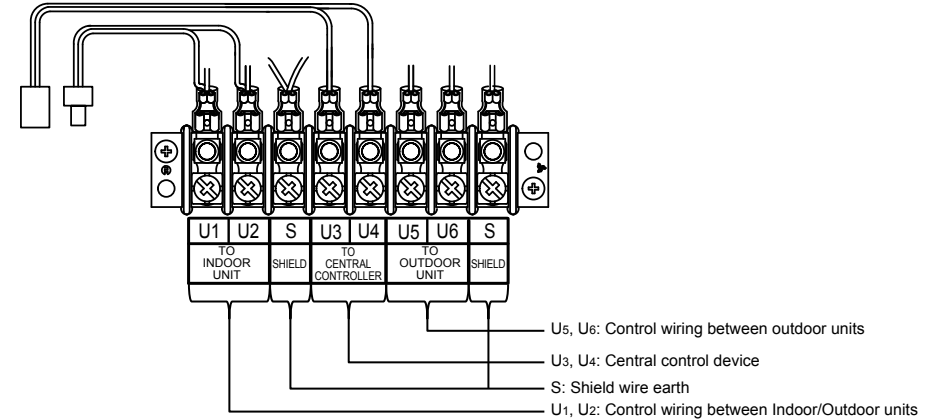

Screw size and tightening torque

	Screw size	Tightening torque ft·lbs(N·m)
control wire terminal	M3.5	0.6 to 0.7(0.80 to 0.96)

9 Address setting

⚠ CAUTION

- Complete all electric wiring before setting the addresses.
- To set the addresses correctly, the indoor units must be energized before the outdoor units are energized. Failure to follow this procedure will result in an "E19" check code being displayed on the outdoor unit control board.
- It normally takes 5 minutes to automatically address one refrigerant line, however this process could take as long as 10 minutes.
- Simply energizing the system components does not initiate the address process.
- It is not required to run the unit during the address process.
- The address process can be done automatically or manually.

⚠ WARNING

- Electrical shock hazard - the electrical control box contains high voltage parts. All adjustments for address setting should be made through the access cover. Do not remove the electrical control box cover.
- After completing the address setting the access cover should be closed and secured using the screw provided.

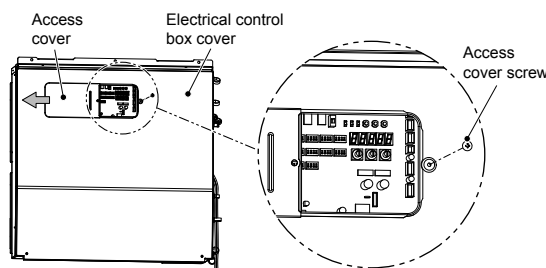

■ Automatic address setting

Without central control
or with central control of 1 refrigerant lines (Example 1) :
With central control of 2 refrigerant lines (Example 2) :

use Address setting procedure 1

use Address setting procedure 2

	Example 1 When a single refrigerant line is centrally controlled	Example 2 When 2 or more refrigerant lines are centrally controlled
Address setting procedure	See procedure 1	See procedure 2
Control wiring diagram		

◆ Address setting procedure 1

- 1 Energize indoor units first, and then energize outdoor units.
- 2 About one minute after energizing the outdoor units, confirm that the 7-segment display on the interface P.C. board of the header outdoor unit indicates **U. 1. L08**. The U.1. will B6 flashing.
- 3 Press SW 15 to start the automatic address setting.
It normally takes 5 minutes, but may take as long as 10 minutes to complete the auto address setting for 1 refrigerant line.
- 4 The 7 segment display will indicate **Auto 1 → Auto 2 → Auto 3**.
When the address sequence has covered all the fan coils for a refrigerant line auto - the 7 segment display will indicate **U. 1.** flashing.
When the flashing stops and the display indicates **U. 1.** without flashing, the address setting is complete.

Interface P.C. board on the header outdoor unit

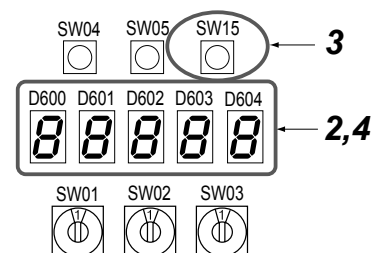

REQUIREMENT

- When 2 or more refrigerant lines are controlled as a group (using 1 remote control), be sure to turn on all the indoor units in the group before setting the addresses.
- If the unit address of each refrigerant line is set separately, then the header unit for each line will be set separately. In this case the remote control will display CODE No. "L03" indicating "indoor header unit overlap" when the system starts running. When this happens the group address must be changed to make only one unit the header unit. This operation is done using the wired remote control.

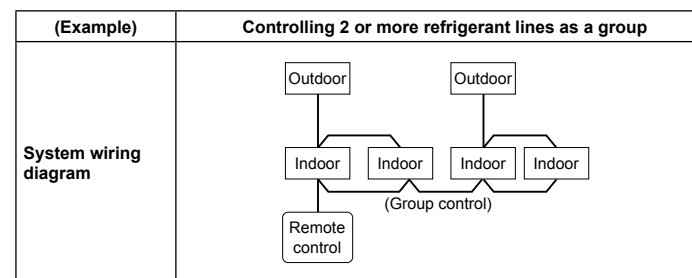

◆ Address setting procedure 2

- 1 Set a system address for each system using SW 13 and 14 on the interface P.C. board for the header outdoor unit of each system.
(Factory default: Address 1)

NOTE

Set a unique address for each system. Do not reuse any address from another system (refrigerant line).

Interface P.C. board on the header outdoor unit

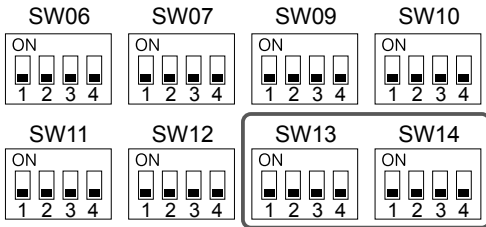

Switch settings for a line (system) address on the interface P.C. board for the outdoor unit
(X: switch OFF)

Line (system) address	SW13	SW14			
	4	1	2	3	4
1	X	X	X	X	X
2	X	ON	X	X	X
3	X	X	ON	X	X
4	X	ON	ON	X	X
5	X	X	X	ON	X
6	X	ON	X	ON	X
7	X	X	ON	ON	X
8	X	ON	ON	ON	X
9	X	X	X	X	ON
10	X	ON	X	X	ON
11	X	X	ON	X	ON
12	X	ON	ON	X	ON
13	X	X	X	ON	ON
14	X	ON	X	ON	ON
15	X	X	ON	ON	ON
16	X	ON	ON	ON	ON
17	ON	X	X	X	X
18	ON	ON	X	X	X
19	ON	X	ON	X	X
20	ON	ON	ON	X	X
21	ON	X	X	ON	X
22	ON	ON	X	ON	X
23	ON	X	ON	ON	X
24	ON	ON	ON	ON	X
25	ON	X	X	X	ON
26	ON	ON	X	X	ON
27	ON	X	ON	X	ON
28	ON	ON	ON	X	ON

- 2 The connectors between the [U1U2] and [U3U4] terminals on all the header outdoor units (that will be connected to the central control) should be open as shown.

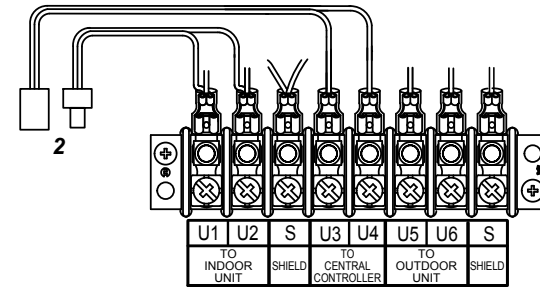

- 3 Energize indoor units first, and then energize outdoor units.
- 4 About 1 minute after turning energizing the outdoor units, confirm that the 7-segment display on the interface P.C. board of the header outdoor unit indicates **U. 1. L08**. The U.1. will be flashing.
- 5 Press SW15 to start the automatic address setting.
It normally takes 5 minutes, but may take as long as 10 minutes to complete the auto address setting for 1 refrigerant line.
- 6 The 7 segment display will indicate **Auto 1 → Auto 2 → Auto 3**.
When the address sequence has covered all the fan coils for a refrigerant line auto - the 7 segment display will indicate **U. 1.** flashing.
When the flashing stops and the display indicates **U. 1.** without flashing, the address setting is complete.
- 7 Repeat steps 4 to 6 for every refrigerant line in the system.
- 8 After completing address setting of all systems, turn off DIP switch 2 of SW30 on the interface P.C. boards of all the header outdoor units connected to the same central control, except the unit that has the lowest address.

- 9 Close the connectors between the [U1, U2] and [U3, U4] terminals on all the header outdoor units (As shown).

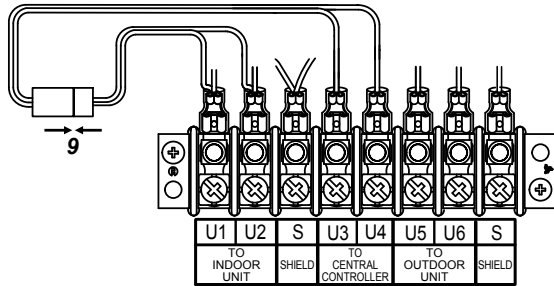

- 10 Set the central control address.

(For setting the central control address, refer to the installation manuals for the central control devices.)

Header unit interface P.C. board

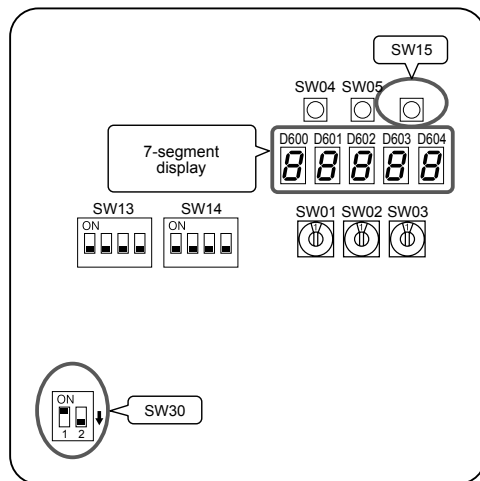

Switch setting (setting example when controlling 2 or more refrigerant lines centrally)
Outdoor units (setting manually)

*The items in bold font must be set manually.

Outdoor unit's interface P.C. board	Header unit	Follower unit	Header unit	Follower unit	Header unit	Factory default
SW13, 14 (See chart on page 19) (Line (system) address)	1	(No setting required)	2	(No setting required)	3	1
DIP switch 2 of SW30 (See the figure on page 20) (Terminator of indoor/outdoor system interconnecting line and central control line)	ON	(No setting required)	Set to OFF after setting addresses.	(No setting required)	Set to OFF after setting addresses.	ON
Connector	Connect after setting addresses.	Open	Connect after setting addresses.	Open	Connect after setting addresses.	Open

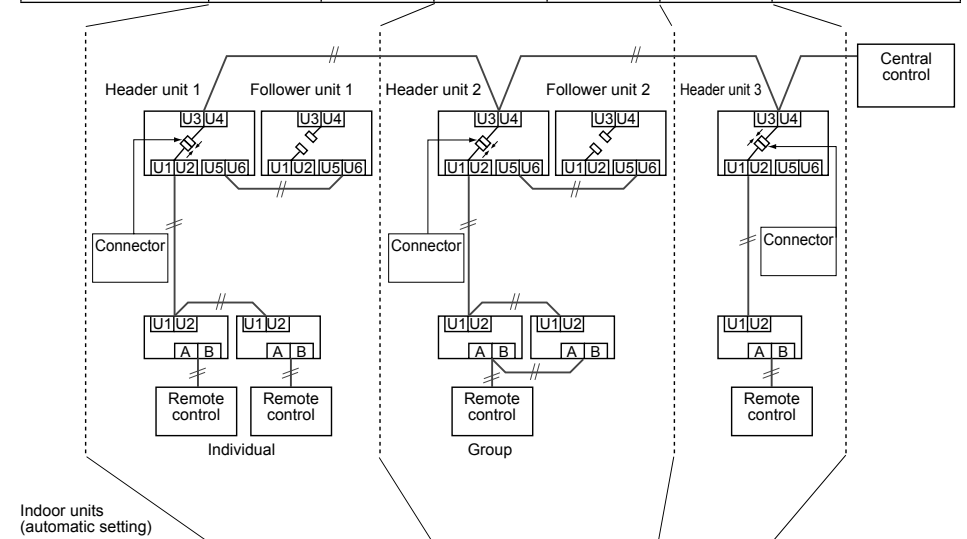

Indoor units (automatic setting)

Line (system) address	1	1	2	2	3
Indoor unit address	1	2	1	2	1
Group address	0	0	1	2	0

Manual address setting using a remote control

This procedure should be used if the indoor unit wiring is completed and the outdoor unit wiring has not been started.

For this procedure the group remote control should not be connected. One individual remote control should be used to set the address on each individual indoor unit (one unit at a time), by wiring the remote control directly to the indoor unit that is to be addressed.

When the address setting procedure is completed for the individual indoor units the group remote control should be connected as shown.

CAUTION

Connector

Do not close the connectors between the (U1, U2) and (U3, U4) terminals before completing all refrigerant line address setting. If a connector is closed the address cannot be set correctly.

Wiring example for 2 refrigerant lines

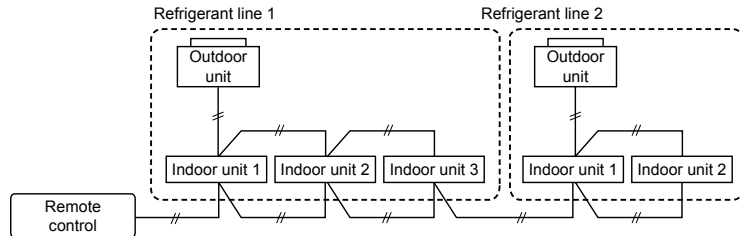

Line (system) address	1	1	1	2	2
Indoor unit address	1	2	3	1	2
Group address	1	2	2	2	2
	Header unit	Follower unit	Follower unit	Follower unit	Follower unit

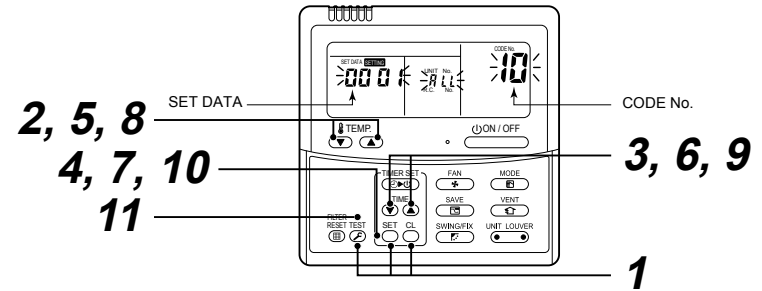

Turn on the power.

- 1 Push and hold the **SET**, **CL**, and **TEST** buttons at the same time for more than 4 seconds. The LCD display will start flashing.

To set-line (system) address

- 2 Push the **TEMP.** (▼/▲) buttons repeatedly to set the **CODE No.** to **13**.
- 3 Push the **TIME** (▼/▲) buttons repeatedly to set a **system address**. (Match the address with the address on the interface P.C. board of the header outdoor unit in the same refrigerant line.)
- 4 Push **SET** button. (This saves the setting.)

To set-indoor unit address

- 5 Push the **TEMP.** (▼/▲) buttons repeatedly to set the **CODE No.** to **13**.
- 6 Push the **TIME** (▼/▲) buttons repeatedly to set an **indoor unit address**.
- 7 Push the **SET** button. (This saves the setting.)

To set-group address

- 8 Push the **TEMP.** (▼/▲) buttons repeatedly to set the **CODE No.** to **14**.
- 9 Push the **TIME** (▼/▲) buttons repeatedly to set a **group address**. If the indoor unit is individual, set the address to **0000**; header unit, **0001**; follower unit, **0002**.

Individual	: 0000	} In case of group control
Header unit	: 0001	
Follower unit	: 0002	

- 10 Push the **SET** button. (This saves the setting.)

- 11 Push the **TEST** button.

The address setting is complete. (SETTING flashes. The unit can be controlled after SETTING has disappeared.)

NOTE



1. Do not use address numbers **29** or **30** when setting system addresses using the remote control. These 2 address numbers cannot be used on outdoor units and the CODE No. **[E04]** (Indoor/outdoor communication trouble) will appear if they are mistakenly used.
2. If addresses to indoor units are set in 2 or more refrigerate lines manually by using the remote control and will control them centrally, set the header outdoor unit of each line as below.
 - Set a system address for the header outdoor unit of each line with SW13 and 14 of their interface P.C. boards.
 - Turn off DIP switch 2 of SW30 on the interface P.C. boards of all the header outdoor units connected to the same central control, except the unit that has the lowest address. (For unifying the termination of the wiring for the central control of indoor and outdoor units)
 - Connect the relay connectors between the [U1, U2] and [U3, U4] terminals on the header outdoor unit of each refrigerate line.
 - After finishing all the settings above, set the address of the central control devices. (For the setting of the central control address, refer to the installation manuals of the central control devices.)

■ Using the remote control to review the address and position of an indoor unit

How to determine an indoor unit address if the unit position is known.

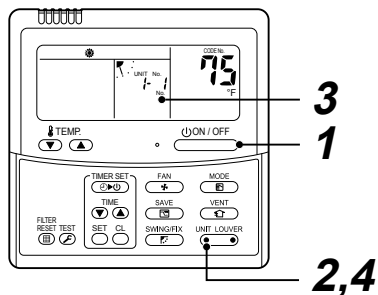
This instruction works for indoor units that have individual, or group control. This must be done while the units are operating.





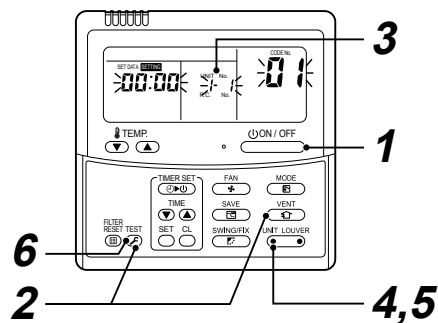

- 1 If the unit is "OFF" turn it "ON" .
- 2 Push the left end of the "UNIT LOUVER"  button.
- 3 Unit number will be indicated on the control LCD as shown above. The numbers will disappear after a few seconds. The numbers indicate the system address and the unit address for the indoor unit in question.
- 4 If 2 or more indoor units are connected to a group control the address for the next consecutive unit will appear each time the left end of the "UNIT LOUVER"  button is pushed.

How to determine an indoor unit position if the unit address is known.

This instruction works for group controlled units only. This instruction must be done while the units are not operating.









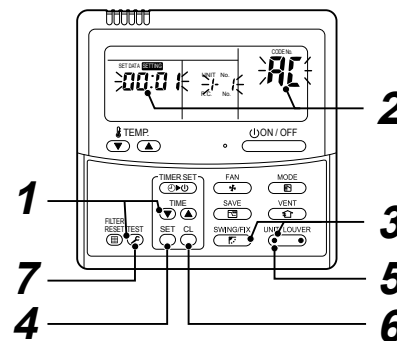

- 1 If the unit is "ON" turn it "OFF" .
- 2 Simultaneously push and hold the "VENT"  and "TEST"  buttons for more than 4 seconds.
- 3 "ALL ALL" will appear on the control LCD display. The fans and louvers of all the indoor units in the control group will be activated.
- 4 Push the left end of the "UNIT LOUVER"  button.
- 5 Each time the left of the button is pushed the next consecutive indoor unit address (in the group) will be displayed. While the address is displayed the fan and louvers for that indoor unit will operate. For all other units in the group the fan and louvers will stop.
- 6 Push the "TEST"  button to finish the procedure. All the indoor units in the control group will stop.

▼ How to use a single remote control to check all the indoor unit address when 2 or more refrigerant lines are connected to a central control.

This must be done while the units are not operating. Use this method to check the indoor unit address and position for each indoor unit on a single refrigerant line.











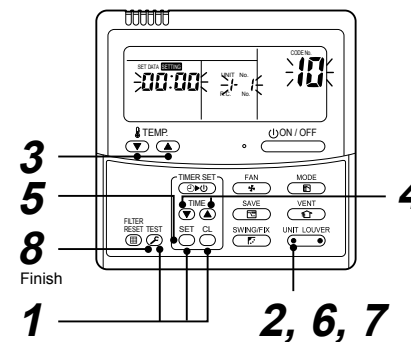

- 1 Simultaneously push and hold the "TIME"  and "TEST"  buttons for more than 4 seconds.
- 2 The LCD will display "LINE 0001" and "CODE No. RL".
- 3 Push the left end of the "UNIT LOUVER"  button and the "SWING/FIX"  repeatedly to select a system address.
- 4 Push the "SET"  button to confirm the address selection. The address of an indoor unit that is connected to the selected refrigerant line will be displayed on the LCD. The fan and louvers for that unit will be energized.
- 5 Each time the left end of the "UNIT LOUVER"  button is pushed the indoor unit numbers of the selected refrigerant line are displayed consecutively. The fan and louvers of the selected unit will be energized.
- 6 Push the "CL"  button to return to step 3 and select another refrigerant line and follow steps 3 to 5 to check indoor unit addresses for that line.
- 7 Push the "TEST"  button to finish the procedure.

■ How to change an indoor unit address by using a wired remote control

Use this method to change the address of indoor units (one to one or group control) that have had the original address set automatically.

This procedure must be done while the units are not operating.



- 1 Simultaneously push and hold the "SET" , "CL" , and "TEST"  buttons for more than 4 seconds. If there are 2 or more units in a group, the first "UNIT No." indicated is the header unit.
- 2 Push the left end of the "UNIT LOUVER"  button repeatedly to select an indoor unit address to change. If 2 or more units are controlled in a group the fan and louvers of the selected unit will be energized.
- 3 Push the TEMP.  buttons repeatedly to select $\{3\}$ for CODE No..
- 4 Push the TIME  buttons repeatedly to change the value indicated in the SET DATA section.
- 5 Push the "SET"  button, to save address.
- 6 Push left and of the "UNIT LOUVER"  button repeatedly to select another indoor unit addresses to change. Repeat steps 4 through 6 to continue changing indoor unit address and make each of them unique.
- 7 Push the left end of the "UNIT LOUVER"  button to review/confirm the revised addresses.

- 8** If the addresses have been changed correctly, push the “TEST SET” button to finish the procedure.
- ▼ How to change indoor unit address for 2 or more refrigerant lines (that are interconnected for central control), when the original addresses were set automatically, by using single wired remote control.
- This must be done while the units are not operating.

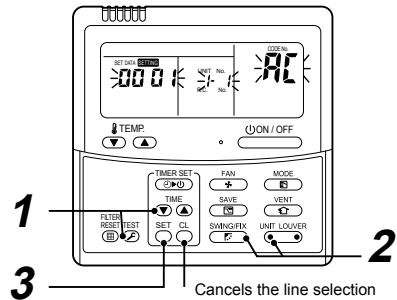

- 1** Simultaneously push and hold the “TIME” and “TEST” for more than 4 seconds. “LINE 0001” and “CODE No. RC” will be displayed on the LCD.
- 2** Push the left end of the “UNIT LOUVER” button and the “SWING/FIX” repeatedly to select a system address.
- 3** Push the “SET” button and the address of one of the indoor units on the selected refrigerant line will be displayed on the LCD in the “SET DATA” field. The fan and louvers of the addressed unit will operate.

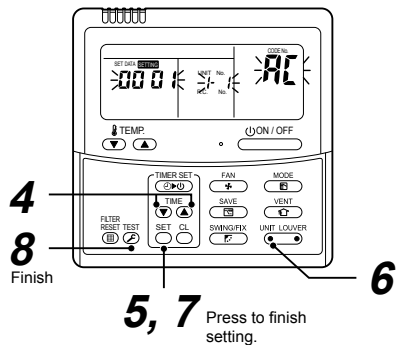

- 4** Push the “TIME” buttons repeatedly to change the value of the indoor unit address in SET DATA. Change the value in SET DATA to that of a new address.
- 5** Push the “SET” button to confirm the new address in SET DATA.
- 6** Push the left end of the “UNIT LOUVER” button repeatedly to an address to change. Each push of the button indicates another indoor unit address in the selected refrigerant line. When an indoor unit address is selected for change the fan and louvers of that unit will operate. Repeat steps 4, 5 and 6 to change an indoor unit address. Each address must be unique.
- 7** Push the “SET” button to save the changed addresses.
- 8** Push the “TEST” button to finish the procedure.

Resetting to factory default address

Method 1

Follow steps 1 through 11 by using a direct wired remote control (page 21) to reset line (system) address, indoor unit addresses and group addresses to “0099”.

Method 2

Clearing all the indoor unit addresses on a single refrigerant line and reset all addresses to the factory default settings follow the steps below:

1. To turn off the refrigerant line and reset all address to the factory default settings follow the steps below:
- On the header outdoor unit, open the connector between (U1, U2) and (U3, U4) terminals.
 - On the header outdoor, interface PC board, SW30 DIP switch 2, set to ON.

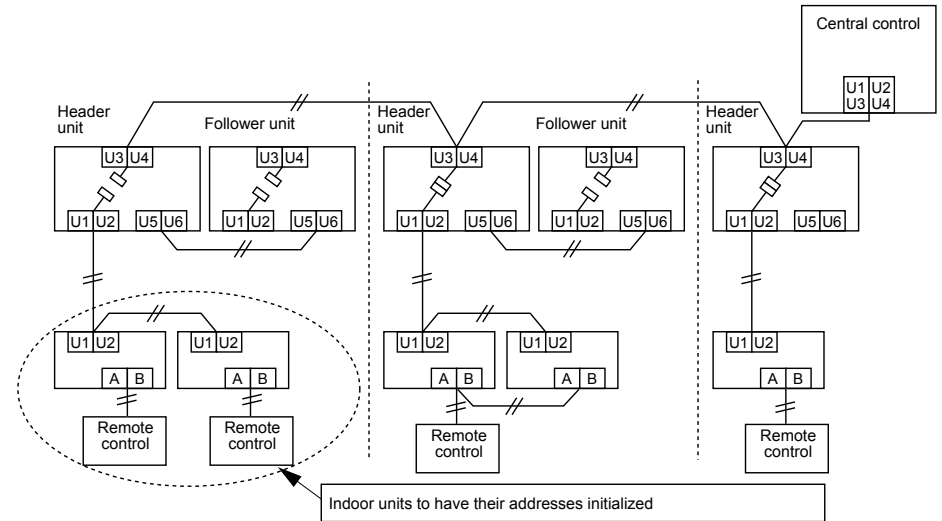

- 1** Turn on the indoor and outdoor units of the refrigerant line for which initialize the addresses to be initialized. About one minute after turning on the power, confirm that the 7-segment display on the header outdoor unit indicates “U.1. - -” and operate the interface P.C. board on the header outdoor unit of the refrigerant line as follows:

SW01	SW02	SW03	SW04	Clearable addresses
2	1	2	Confirm that the 7-segment display indicates “A.d.buS” and turn SW04 ON for more than five seconds.	System/indoor unit/group address
2	2	2	Confirm that the 7-segment display indicates “A.d.nEt” and turn SW04 ON for more than five seconds.	Central control address

- 2** Confirm that the 7-segment display indicates “A.d. c.L.” and set SW01, SW02 and SW03 to 1, 1, 1 respectively.
- 3** After a time “U.1.L08” appears on the 7-segment display if the address clearing has been completed successfully.
- 4** Set the addresses again after finishing the clearance.

10 Test run

CAUTION

- Turn on the power and turn on the case heater of the compressor.
To save the compressor when it is activated, leave the power on for more than 12 hours.

Methods of test run

A test run is executed by using a remote control

Operate the system normally to check the running condition using the wired remote control. Follow the instructions in the supplied owner's manual when operating the unit.

If a wireless remote control is used for operations, follow the instructions in the installation manual supplied with the indoor unit.

To execute a test run forcibly under the condition that the thermostat automatically turns the unit off due to the indoor temperature, follow the procedure below. The forcible test run will automatically stop after 60 minutes to prevent continuous forcible running and return to normal running.

CAUTION

Do not use forcible running except for a test run as it overloads the unit.

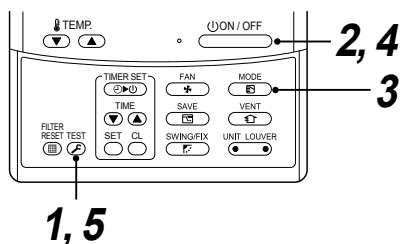

- Push and hold the **TEST** button for more than 4 seconds. **TEST** appears on the LCD and the unit enters the **TEST** mode.

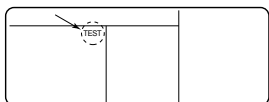

- Push the **ON/OFF** button.
- Push the **MODE** button to switch the running mode to **COOL** or **HEAT**.

NOTE

- Do not run the unit in any mode other than **COOL** or **HEAT**.
- The temperature setting cannot be changed during the test run.
- Check codes are detected as usual.

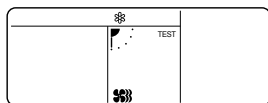

- Push the **ON/OFF** button to stop running after finishing the trial run. The indication on the LCD display returns to the status of procedure 1.

- Push the **TEST** button to exit the test mode. (**TEST** disappears on the LCD display and the status changes to normal stopped mode.)

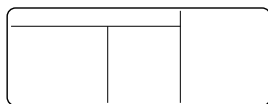

When a test run is executed by using the interface P.C. board on the outdoor unit

A test run can be executed by operating switches on the interface P.C. board of the header outdoor unit. "Individual test", which tests each indoor unit separately, and "collective test", which tests all the indoor units connected, are available.

<Individual test operation>

Starting operation

- Set the running mode to "COOL" or "HEAT" on the remote control of the indoor unit to be tested.
(The unit will run in the current mode unless the mode is set otherwise.)

7-segment display	
[A] [U1]	[B] []

- Set the rotary switches on the interface P.C. board of the header outdoor unit: **SW01** to [16], **SW02** and **SW03** to the address of the indoor unit to be tested.

SW02	SW03	Indoor unit address	
1 to 16	1	1 to 16	Set number of SW02
1 to 16	2	17 to 32	Set number of SW02 + 16
1 to 16	3	33 to 48	Set number of SW02 + 32
1 to 16	4	49 to 64	Set number of SW02 + 48

7-segment display	
[A] []	[B] []
Address display of the corresponding indoor unit	

- Push and hold **SW04** for more than 10 seconds.

7-segment display	
[A] []	[B] []
Address display of the corresponding indoor unit	
[FF] is displayed for 5 seconds.	

NOTE

- The running mode follows the mode setting on the remote control of the target indoor unit.
- The temperature setting cannot be changed during the test run.
- Check codes are detected as usual.
- The unit does not perform test run for 3 minutes after energized or terminating the operation.

Finishing operation

- Set the rotary switches on the interface P.C. board of the header unit back: **SW01** to [1], **SW02** to [1] and **SW03** to [1].

7-segment display	
[A] [U1]	[B] []

Collective test operation

Start operation

- Set the rotary switches on the interface P.C. board of the header outdoor unit as below.
When in "COOL" mode: **SW01**=[2], **SW02**=[5], **SW03**=[1].
When in "HEAT" mode: **SW01**=[2], **SW02**=[6], **SW03**=[1].

7-segment display	
[A] [C] [H]	[B] []

2 Push and hold SW04 for more than 2 seconds.

NOTE

- The temperature setting cannot be changed during the test run.
- Check codes are detected as usual.
- The unit does not perform test run for 3 minutes after turning the power on or stopping running.

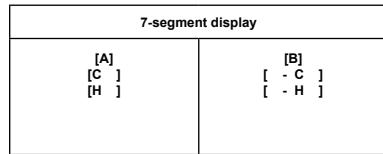

▼ Stop operation

1 Set the rotary switches on the interface P.C. board of the header unit back: SW01 to [1], SW02 to [1] and SW03 to [1].

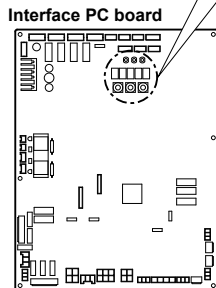
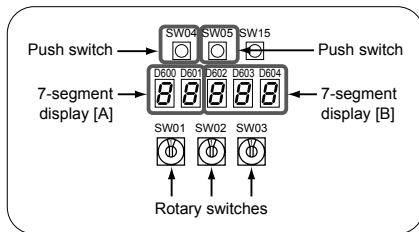
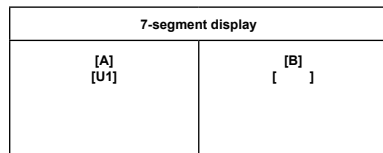

11 Troubleshooting

In addition to the CODE No. on the remote control of an indoor unit, you can diagnose failure type of an outdoor unit by checking the 7-segment display on the interface P.C. board. Use the function for various checks. Set every DIP switch to OFF after checking.

7-Segment display and check code

Rotary switch setting value			Indication	LED	
SW01	SW02	SW03			
1	1	1	Outdoor unit check code	A B	Outdoor unit number (U ₁ to U ₃) Check code display*

* If a check code has an auxiliary code, the display indicates the check code for three seconds and the auxiliary code for one second alternately.

Check code (indicated on the 7-segment display on the outdoor unit)

Indicated when SW01 = [1], SW02 = [1], and SW03 = [1].

Check code		Check code name
Indication on 7-segment display on the outdoor unit	Auxiliary code	
E06	Number of indoor units which received normally	Decrease of number of indoor units
E07	—	Indoor/outdoor communication circuit trouble
E08	Duplicated indoor addresses	Duplication of indoor addresses.
E12	01: Communication between indoor and outdoor units 02: Communication between outdoor units	Automatic addressing start trouble
E15	—	No indoor unit during automatic addressing
E16	00: Capacity over 01~: Number of connected units	Capacity over / number of connected indoor units
E19	00: Header is nothing 02: 2 or more header units	Number of header outdoor unit trouble
E20	01: Other line outdoor connected 02: Other line indoor connected	Other lines connected during automatic addressing
E23	—	Sending trouble between outdoor units communication
E25	—	Duplicated follower outdoor address set up
E26	Number of outdoor units which received normally	Decrease of connected outdoor units
E28	Detected outdoor unit No.	Follower outdoor unit trouble
E31	IPDU quantity information ⁽¹⁾	IPDU communication trouble
E31	80	Communication trouble between MCU and sub MCU
F04	—	TD1 sensor trouble
F05	—	TD2 sensor trouble
F06	01: TE1 sensor 02: TE2 sensor	TE1 sensor trouble TE2 sensor trouble
F07	01: TL1 sensor 02: TL2 sensor 03: TL3 sensor	TL1, TL2 or TL3 sensor trouble
F08	—	TO sensor trouble
F09	01: TG1 sensor 02: TG2 sensor	TG1 or TG2 sensor trouble
F12	01: TS1 sensor 03: TS3 sensor	TS1 or TS3 sensor trouble
F13	01: Compressor 1 02: Compressor 2	TH (Heat sink) sensor trouble

Check code		Check code name
Indication on 7-segment display on the outdoor unit		
	Auxiliary code	
F15	—	Outdoor temp. sensor miswiring (TE1, TL1)
F16	—	Outdoor pressure sensor miswiring (Pd, Ps)
F23	—	Ps sensor trouble
F24	—	Pd sensor trouble
F31	—	Outdoor EEPROM trouble
H01	01: Compressor 1 02: Compressor 2	Compressor breaking down
H02	01: Compressor 1 02: Compressor 2	Compressor trouble (Locked)
H03	01: Compressor 1 02: Compressor 2	Current detection circuit trouble
H05	—	TD1 sensor miswiring
H06	—	Low pressure protective operation
H07	—	Oil level down detection
H08	01: TK1 sensor trouble 02: TK2 sensor trouble 04: TK4 sensor trouble 05: TK5 sensor trouble	Temperature sensor trouble for oil level
H15	—	TD2 sensor miswiring
H16	01: TK1 oil circuit trouble 02: TK2 oil circuit trouble 04: TK4 oil circuit trouble 05: TK5 oil circuit trouble	Oil level detector circuit trouble
L02	Model mismatch of indoor and outdoor unit	System shutdown trouble from indoor unit
L04	—	Outdoor system address duplication
L06	Number of prior indoor units	Duplication of indoor units with priority
L08	—	Indoor unit group/address unset
L10	—	Outdoor unit capacity unset.
L17	—	Inconsistent models of outdoor units
L28	—	Outdoor connected quantity over
L29	IPDU number information ^(*)	IPDU quantity trouble
L30	Detected indoor unit address	External interlock of indoor unit
L31	—	Other compressor trouble
P03	—	Discharge temperature TD1 trouble
P04	01: Compressor 1 02: Compressor 2	High-pressure SW system operation
P05	00:	Phase missing detection/Phase order trouble
	01: Compressor 1 02: Compressor 2	Compressor Vdc trouble

Check code		Check code name	
Indication on 7-segment display on the outdoor unit			
	Auxiliary code		
P07	01: Compressor 1 02: Compressor 2	Heat sink overheat trouble	
	Detected indoor unit address	Indoor overflow trouble	
P10	—	Outdoor unit flow back trouble detected	
P13	—	Outdoor unit flow back trouble detected	
P15	01: TS condition 02: TD condition	Gas leak detection	
P17	—	Discharge temperature TD2 trouble	
P19	Detected outdoor unit number	4-way valve inverse trouble	
P20	—	High-pressure protective operation	
P22	#0: Element short circuit	Outdoor fan IPDU trouble	
	#E: Vdc voltage trouble		
	#1: Position detection circuit trouble		
	#2: Input current sensor trouble		
	#3: Motor lock trouble		
	#C: Sensor temperature trouble (No TH sensor)		
#4: Motor current trouble	Outdoor fan IPDU trouble		
#D: Sensor short circuit/release trouble (No TH sensor)			
#5: Synchronization/step-out trouble			
*Put in Fan IPDU No. in [#] mark.			
P26		01: Compressor 1 02: Compressor 2	G-TR short protection trouble
P29		01: Compressor 1 02: Compressor 2	Compressor position detecting circuit trouble

***IPDU number information**

01: Compressor 1 trouble
02: Compressor 2 trouble
03: Compressor 1 and 2 trouble
08: Fan1 trouble
09: Compressor 1, Fan 1 trouble
0A: Compressor 2, Fan 1 trouble
0B: Compressor 1 and 2, Fan 1 trouble

11: Compressor 1, Fan 2 trouble
12: Compressor 2, Fan 2 trouble
13: Compressor 1 and 2, Fan2 trouble
18: Fan 1 and 2 trouble
19: Compressor 1, Fan 1 and 2 trouble
1A: Compressor 2, Fan 1 and 2 trouble
1B: All

SMMS wave tool

"SMMS wave tool" is an application software ("Application") for the Android OS smartphone and for those who install and do maintenance to the compatible air conditioning equipment. The Application enables checks of some of the system and data and test operations of compatible air conditioning equipment. Please check the information about compatible air conditioning equipment and smartphone from the below URL. Be sure to read the Operating Manual before the use of this Application, "SMMS wave tool". You can download the Application and the Operating Manual from the below URL or QR code. QR code is a trademark or registered trademark of DENSO WAVE Inc. Android is a trademark or registered trademark of Google Inc.



QR code

URL: http://www.toshiba-carrier.co.jp/global/appli/smms_wave_tool/

NOTICE

- This Application enables the auto-address setup and the test operation of the outdoor unit by smartphone in 48 hours from the power input to the outdoor unit.
- You should decide whether to make use of this auto-address setup and test operation function at its own responsibility and also be sure to confirm notices in the Operating Manual before performing the test operation.
- If you want to disable the function of the auto-address setup and the test operation, perform the following operations.
- Refer to the service manual for setting change of the auto-address setup and the test operation function to be effective.

Switch setting of some functions prohibition

Step	Rotary switch			Push switch	7-segment display	Condition
	SW01	SW02	SW03	SW04	[A] [B]	
(1)	2	1	14	—	[nf] [c.00]	Setting preparation
(2)	2	1	14	Press for more than 5 secs	[nf] [c.01]	Setting completion
(3)	1	1	1	—	[U.1.] [- - -]	Return the switch

- * Do it again if the 7-segment display is different from the above.
- * The functions other than the auto-address setup and test operation of this Application can work normally even if the auto-address set up and test operation function are disabled.

CAUTION

- High voltage parts exist in the electrical control box. If you set Switch setting, set it from the access door cover of the electrical control box cover to avoid electric shock.
- After finishing operations, slide the access door cover to the position before and fix it with the screw.

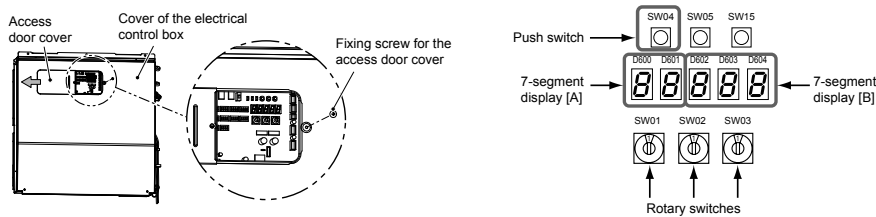

HOW TO USE

- This Application uses the NFC (Near Field Communication) function of smartphone.
- For the use, hold your smartphone to the "TOUCH" mark of the outdoor unit.
- Refer to the Operating Manual of the "SMMS wave tool" for the details.

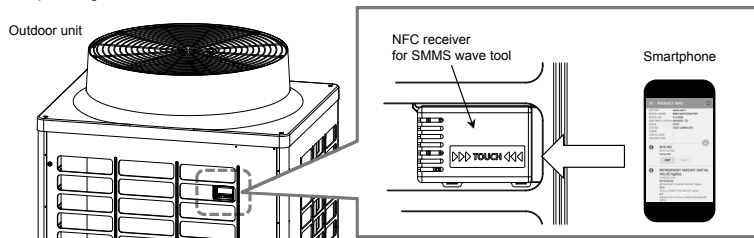

WARNINGS ON REFRIGERANT LEAKAGE

Check of Concentration Limit

The room in which the air conditioner is to be installed requires a design that in the event of refrigerant gas leaking out, its concentration will not exceed a set limit. The refrigerant R410A which is used in the air conditioner is safe, without the toxicity or combustibility of ammonia, and is not restricted by laws to be imposed which protect the ozone layer. However, since it contains more than air, it poses the risk of suffocation if its concentration should rise excessively. Suffocation from leakage of R410A is almost non-existent. With the recent increase in the number of high concentration buildings, however, the installation of multi air conditioner systems is on the increase because of the need for effective use of floor space, individual control, energy conservation by curtailing heat and carrying power etc. Most importantly, the multi air conditioner system is able to replenish a large amount of refrigerant compared with conventional individual air conditioners. If a single unit of the multi conditioner system is to be installed in a small room, select a suitable model and installation procedure so that if the refrigerant accidentally leaks out, its concentration does not reach the limit (and in the event of an emergency, measures can be made before injury can occur). In a room where the concentration may exceed the limit, create an opening with adjacent rooms, or install mechanical ventilation combined with a gas leak detection device. The concentration is as given below.

$$\frac{\text{Total amount of refrigerant (lbs (kg))}}{\text{Min. volume of the indoor unit installed room (ft}^3 \text{ (m}^3\text{))}} \leq \text{Concentration limit (lbs/ft}^3 \text{ (kg/m}^3\text{))}$$

Concentration limit

Compliance to the local applicable regulations and standards for the concentration limit is required.

NOTE 1 :

If there are 2 or more refrigerating systems in a single refrigerating device, the amounts of refrigerant should be as charged in each independent device.

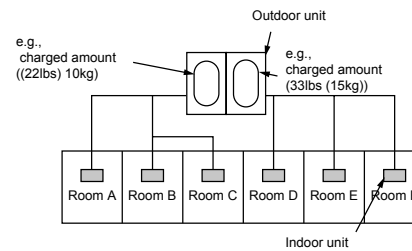

For the amount of charge in this example:
 The possible amount of leaked refrigerant gas in rooms A, B and C is 22lbs (10kg).
 The possible amount of leaked refrigerant gas in rooms D, E and F is 33lbs (15kg).

Important

NOTE 2 :

The standards for minimum room volume are as follows.

- (1) No partition (shaded portion)

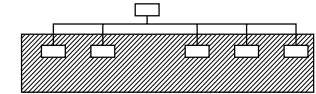

- (2) When there is an effective opening with the adjacent room for ventilation of leaking refrigerant gas (opening without a door, or an opening 0.15% or larger than the respective floor spaces at the top or bottom of the door).

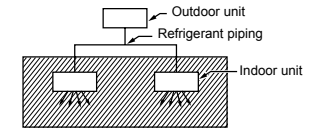

- (3) If an indoor unit is installed in each partitioned room and the refrigerant piping is interconnected, the smallest room of course becomes the object. But when a mechanical ventilation is installed interlocked with a gas leakage detector in the smallest room where the density limit is exceeded, the volume of the next smallest room becomes the object.

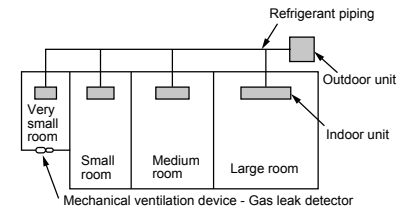

TOSHIBA CARRIER (THAILAND) CO.,LTD.

**144/9 MOO 5, BANGKADI INDUSTRIAL PARK, TIVANON ROAD, TAMBOL BANGKADI,
AMPHUR MUANG, PATHUMTHANI 12000, THAILAND.**

1117906101-1