

DX Interface : Dx-Controller (0-10V type) Installation manual

Model name:

For commercial use

TCB-IFDD1GUL Dx-Controller (0-10V type)

ENGLISH

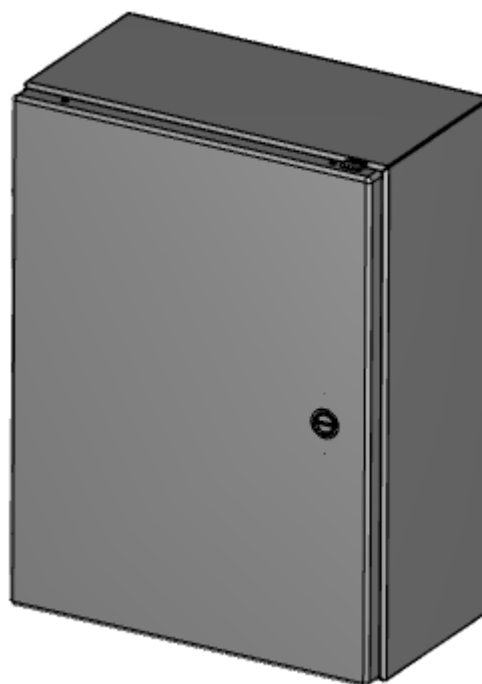

Please read this Installation Manual carefully before installing the Dx Interface 0-10V type.

- This Manual describes the installation method of the Dx-Controller.
- You must also refer to the Installation and Owner's Manual attached to the Toshiba Carrier VRF outdoor unit.
- Please follow the manual(s) for local supplied products and Air Handling Unit.
- Toshiba Carrier North America, Inc. does not take any responsibility on the local design.
- This product is exclusively designed to be connected to a field supplied Dx-Coil and AHU.
- Do not try to fix the controller if there is a malfunction.

ADOPTION OF NEW REFRIGERANT

This Air Conditioner is a new type which adopts a new refrigerant HFC (R410A) instead of the conventional refrigerant R22 in order to prevent destruction of the ozone layer.

This appliance is for commercial use only and should not be accessible to the general public.

This appliance is not intended for use by person (including children) with reduced physical, sensory or mental capabilities, or lack of experience and knowledge, unless they have been given supervision or instruction concerning use of the appliance by a person responsible for their safety.

Children should be supervised to ensure that they do not play with the appliance.

Contents

1	PRECAUTIONS FOR SAFETY	2
2	OVERVIEW : DX INTERFACE 0-10V TYPE.	4
3	SUPPLIED PARTS	5
4	SYSTEM CONFIGURATION.	6
5	INSTALLATION	7
6	ELECTRICAL WORK	10
7	APPLICABLE CONTROLS / BMS INTEGRATION	15
8	TEST RUN	22
9	TROUBLE SHOOTING.	23

1 PRECAUTIONS FOR SAFETY

The manufacturer shall not assume any liability for the damage caused by not observing the description of this manual.

General

- Before starting to install the air conditioner, read through the Installation Manual carefully, and follow its instructions to install the air conditioner.
- Only qualified installer or service person is allowed to do installation work. Inappropriate installation may result in water leakage, electric shock or fire.
- Do not use any refrigerant different from the one specified for complement or replacement. Otherwise abnormally high pressure may be generated in the refrigerant cycle, which may result in a failure or explosion of the product or an injury to your body.
- Before opening the electrical control box or service panel of outdoor unit, set the circuit breaker to the OFF position. Failure to set the circuit breaker to the OFF position may result in electric shocks through contact with the interior parts. Only a qualified installer or qualified service person is allowed to remove the electrical control box cover or service panel of the outdoor unit and do the work required.
- Before carrying out the installation, maintenance, repair or removal work, set the circuit breaker to the OFF position. Otherwise, electrical shocks may result.
- Place a "Work in Progress" sign near the circuit breaker while the installation, maintenance, repair or removal work is being carried out. There is a danger of electric shocks if the circuit breaker is set to ON by mistake.
- Wear protective gloves and safety work clothing during installation, servicing and removal.
- The refrigerant used by this air conditioner is the R410A.

Selection of installation location

- When the air conditioner is installed in a small room, provide appropriate measures to ensure that the concentration of refrigerant leakage occur in the room does not exceed the critical level.
- Do not install in a location where flammable gas leaks are possible. If the gas leak and accumulate around the unit, it may ignite and cause a fire.
- Do not place any combustion appliance in a place where it is directly exposed to the wind of air conditioner. Otherwise, it may cause imperfect combustion.

Installation

- Install the air conditioner securely in a location where the base can sustain the weight adequately. If the strength is not enough, the unit may fall down and result in injury.
- Carry out the specified installation work to guard against the possibility of high winds and earthquake. If the air conditioner is not installed appropriately, a unit may topple over or fall down, causing an accident.
- If refrigerant gas has leaked during the installation work, ventilate the room immediately. If the leaked refrigerant gas comes in contact with fire, noxious gas may be generated.

Refrigerant piping

- Install the refrigerant pipe securely during the installation work before operating the air conditioner. If the compressor is operated with the valve open and without refrigerant pipe, the compressor sucks air and the refrigeration cycles is over pressurized, which may cause a injury.
- After the installation work, confirm that refrigerant gas does not leak. If refrigerant gas leaks into the room and flows near a fire source, such as a cooking range, noxious gas may be generated.
- When the air conditioner has been installed or relocated, follow the instruction in the Installation manual and purge the air completely so that no gases other than the refrigerant will be mixed in the refrigeration cycle. Failure to purge the air completely may cause the air conditioner to malfunction.
- Nitrogen gas must be used for the airtight test.
- The charge hose must be connected in such a way that it is not slack.

Electrical wiring

- Only a qualified installer or qualified service person is allowed to carry out the electrical work of the air conditioner. Under no circumstances must this work be done by an unqualified individual since failure to carry out the work properly may result in electric shocks and/or electrical leaks.
- To connect the electrical wires, repair the electrical parts or undertake other electrical jobs, wear gloves to provide protection for electricians, insulating shoes and clothing to provide protection from electric shocks.
- Use wiring that meets the specifications in the Installation Manual and the stipulations in the local regulations and laws. Using wiring which does not meeting the specifications may lead electric shocks, electrical leakage, smoking and/or a fire.
- Connect earth wire. (Grounding work)

- Incomplete grounding causes an electric shock.
- Do not connect earth wires to gas pipes, water pipes, and lightning conductor or telephone earth wires.
- After completing the repair or relocation work, check that the earth wires are connected properly.
- Install a circuit breaker that meets the specifications in the installation manual and the stipulations in the local regulations and laws.
- Install the circuit breaker where it can be easily accessed for service.
- When installing the circuit breaker outdoors, install one which is designed to be used outdoors.
- Under the circumstances the power wire must not be extended. Connection trouble in the places where the wire is extended may give rise to smoking and/or a fire.
- Electrical wiring work shall be conducted according to law and regulation in the community and installation manual. Failure to do so may result in electrocution or short circuit.

Test run

- Before operating the air conditioner after having completed the work, check that the electrical cover box and service panel of outdoor unit are closed, and set the circuit breaker to the ON position. There is probability of electric shock if the power is turned on without first conducting these checks.
- If there is any kind of trouble (such as an error display appearing, smell of burning, abnormal sounds, the air conditioner fails to cool or heat or water is leaking) has occurred in the air conditioner, do not touch the air conditioner yourself but set the circuit breaker to the OFF position, and contact a qualified service person. Take steps to ensure that the power will not be turned on (by marking “out of service” near the circuit breaker, for instance) until qualified service person arrives. Continuing to use the air conditioner in this status may cause mechanical problems to escalate or result in electric shocks or other trouble.
- After the work has finished, use an insulation tester set (500V Megger) to check the resistance is 1M ohm or more between the charge section and the non-charge metal section (Earth section). If the resistance value is low, a disaster such as a leak or electric shock is caused at user’s side.
- Upon completion of the installation work, check for refrigerant leaks and check the insulation resistance and water drainage. Then conduct a test run to check that the air conditioner is operating properly.

Explanations given to user

- Upon completion of the installation work, tell the user where the circuit breaker is located. If the user does not know where the circuit breaker is, he or she will not be able to turn it off in the event that trouble occurs in the air conditioner.
- After the installation work, follow the Owner’s manual to explain to the customer how to use and maintain the unit.

Relocation

- Only qualified installer or qualified service person is allowed to relocate the air conditioner. It is dangerous for the air conditioner to be relocated by an unqualified individual since a fire, electric shocks, injury, water leakage, noise and/or vibration may result.
- When carrying out the pump-down work, shut down the compressor before disconnecting the refrigerant pipe. Disconnecting the refrigerant pipe with the service valve left open and the compressor still operating will cause air or other gas to be sucked in, raising the pressure inside the refrigeration cycle to an abnormally high level, and possibly resulting in rupture, injury or issues.

CAUTION

New Refrigerant Air Conditioner Installation

■ THIS AIR CONDITIONER ADOPTS THE NEW HFC REFRIGERANT (R410A) WHICH DOES NOT DESTROY OZONE LAYER.

The characteristics of R410A refrigerant are; easy to absorb water, oxidizing membrane or oil, and its pressure is approx. 1.6 times higher than that of refrigerant R22. Accompanied with the new refrigerant, refrigerating oil has also been changed. Therefore, during installation work, be sure that water, dust, former refrigerant, or refrigerating oil does not enter the refrigerating cycle.

To prevent charging an incorrect refrigerant and refrigerating oil, the sizes of connecting sections of charging port of the main unit and installation tools are changed from those of conventional refrigerant.

Accordingly the exclusive tools are required for the new refrigerant (R410A).

For connecting pipes, use new and clean piping designed for R410A, and please take care so that water or dust does not enter the system. Moreover, do not use the existing piping because there are problems with the pressure-resistance force and impurity in it.

2 OVERVIEW: DX INTERFACE 0-10V TYPE

The **Dx-Interface 0-10V type** enables external BMS capacity control of Toshiba Carrier VRF outdoor units connected to an air handling unit with a Dx-Coil.

The Dx-Interface 0-10V type is not designed to be used directly with Fresh Air; it must be used in conjunction with either heat recovery exchanger or pre-conditioning heaters / coolers to ensure that the DX Coil Air On limits are not exceeded.

For VRF Applications the Dx-Interface 0-10V type is only compatible with SMMS-e 6ton, 8ton outdoor units.

Additionally VRF systems require an appropriately sized **Dx-PMV kit** which must be brazed to the Dx-Coil used in conjunction with the Dx-Controller.

The Toshiba Carrier system must be connected 1:1 with a DX-Coil (up to 8ton). DX-Coil's larger than 8ton need to be split into separate interlaced sections (each with separate AHU Dx-Coil Interface and Outdoor unit).

AHU example using SMMS-e Outdoor unit:-

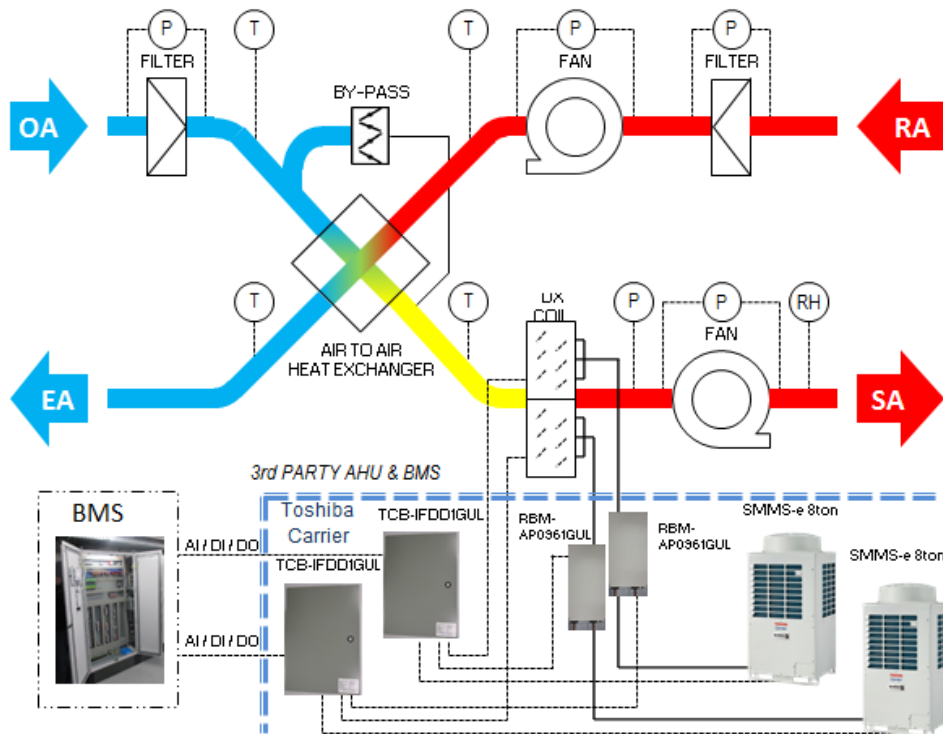

Specifications

Model name	TCB-IFDD1GUL
For use with	SMMS-e (072/096 type)
Power supply V/Hz/Ph	208/230VAC, 60Hz, 1ph
Rating current A	0.3
Ambient operating temperature range (*1)	22 to 115°F
Ambient operating humidity range (*1)	10 to 90% (Non-condensing)
Storage temperature range	-4 to 140°F
Dimension H X W X D in.	16" X 12" X 6.8"
Net weight lbs	19.0
Control pollution degree	Degree 1

(*1) Install in the place avoiding direct sunlight and rain

AHU System Schematic

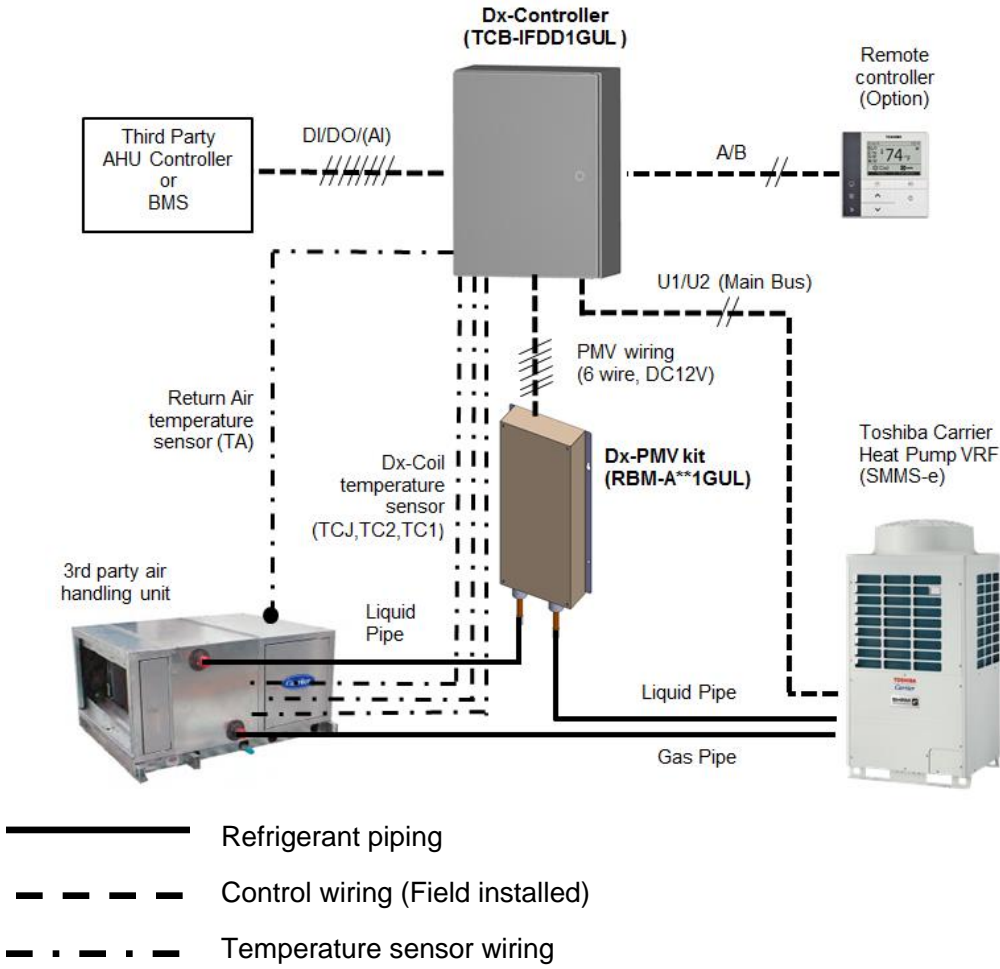

3 SUPPLIED PARTS

VRF applications require the Dx-Controller 0-10V type (**TCB-IFDD1GUL**) plus an appropriately sized Dx-PMV kit.

•The **DX-PMV kit** is a expansion value box to install in liquid line between outdoor unit and 3rd party Dx-coil.

•5ton (60kBtu/h) : **RBM-A0601GUL**

•6ton (72kBtu/h) / 8ton (96kBtu/h) : **RBM-A0961GUL**

TCB-IFDD1GUL Contents

Item	Description	Qty
	TC2 Sensor (6mm) BLK (8ft)	1
	TCJ Sensor (6mm) RED (8ft)	1
	TC1 Sensor (4mm) BLU (8ft)	1
	TA Sensor (Resin) BLK [Return Air] (10ft)	1
	Installation Manual	1

RBM-A0601GUL/RBM-A0961GUL Contents

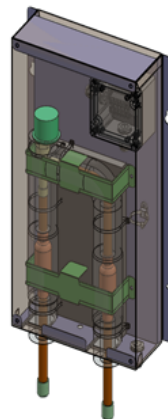

Item	Description	Qty
	Sensor Holder (Ø6) (TCJ / TC2)	2
	Sensor Fix Plate (Ø6)	2
	Sensor Holder (Ø4) (TC1)	1
	Fix Plate (Ø4)	1
	Installation Manual	1

4 SYSTEM CONFIGURATION

Operating Conditions:

AHU	<p>The DX Interface 0-10V type is not designed to be used directly with Fresh Air, it must be used in conjunction with either heat recovery exchanger or pre-conditioning heaters / coolers to ensure that the DX Coil Air On limits are not exceeded., in order to ensure reliable operation:-</p>	
		<p>Cooling mode DX coil "air on" temp: Min: 59°F_{WB} (64°F_{DB}) ~ Max: 75°F_{WB} (95°F_{DB}) Heating mode DX coil "air on" temp: Min: 54°F_{DB}* ~ Max: 82°F_{DB} (*Pull down to 45°F)</p>
Outdoor Unit	Refer to specification of Outdoor Unit	

For DX-Interface 0-10V type uses the following table to determine AHU and Dx-Coil sizes:-

Total Size		ton	5.0	6.0	8.0		
TCB-IFDD1GUL		-	1	1	1		
RBM-A0601GUL		5.0	1	-	-		
RBM-A0961GUL		6.0	-	1	-		
		8.0	-	-	1		
General	Permitted Diversity (%)		75 to 100				
	Air volume range (cfm)		Standard	1850	2400	2800	
			Min.	1480	1920	2240	
			Max.	2220	2880	3360	
	Coil internal volume (in ³)		Standard	200	250	310	
			Min.	170	213	264	
			Max.	230	288	357	
	Number of circuits by U-Pipe diameter		5/16"	Min.	6	8	10
				Max.	8	12	14
			3/8"	Min.	4	6	8
				Max.	6	10	12
			1/2"	Min.	3	4	5
Max.				4	6	6	
Recommended Liquid Capillary Distributor Orifice size (ID inch)		0.21 – 0.24	0.25 – 0.28	0.27 – 0.32			
Total Size		ton	5.0	6.0	8.0		
Cooling	Min. Cooling Capacity (kBtu/h)		30	36	48		
	Max. Cooling Capacity (kBtu/h)		60	72	96		
	Evaporating Temperature		44°F				
	Suction Superheat		8°F				
	Evaporator Air Suction Temp.		80°F _{DB} / 67°F _{WB}				
Heating	Min. Heating Capacity (kW)		34	40	54		
	Max. Heating Capacity (kW)		67	81	108		
	Condensating Temperature		117°F				
	Sub Cooling		12°F				
	Condenser Air Suction Temp.		70°F _{DB}				

AHU / DX Coil Notes & Features:-

- Cooling & Heating output figures are based on calculations and 'general' test data. All figures are to be taken as approximations. The properties of the 3rd Party DX Coil will have an effect on the performance of the Outdoor units.
- The DX Coil must be suitable for R410A.
- The design should allow operation as both an Evaporator and a Condenser (Features: Multiple circuits / Liquid Capillary Distributor / Gas Header)
- The counter flow principle must be observed for the DX coil design
- A Drain Pan must be fitted (even if only used in Heat mode) due to defrost cycles
- It is recommended to fit droplet eliminator plates in the discharge air stream if used in Cool mode.
- Only Heating and Cooling Modes are available on the TC-IFDD1GUL (No Automatic or Fan Only).



5 INSTALLATION

■ Dx-Controller (TCB-IFDD1GUL)

The Dx-Controller must be installed in vertical orientation. Mounting surface temperature limit is 140F.

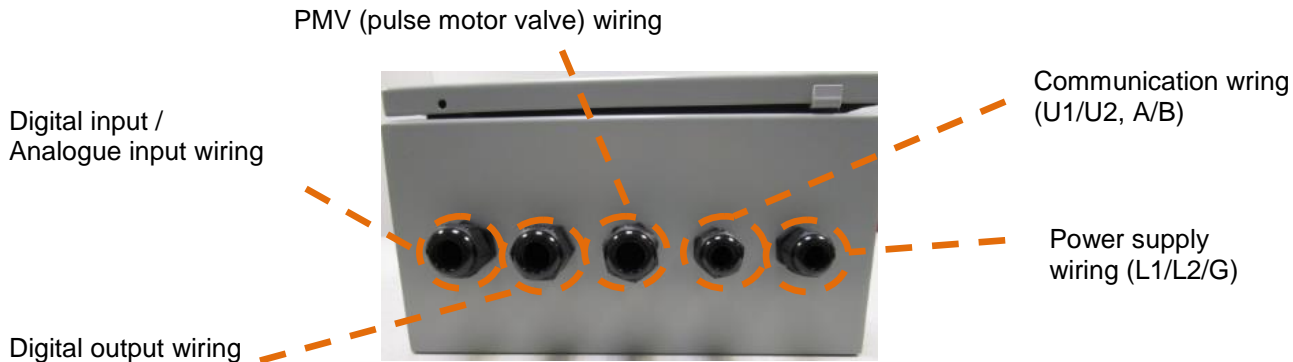
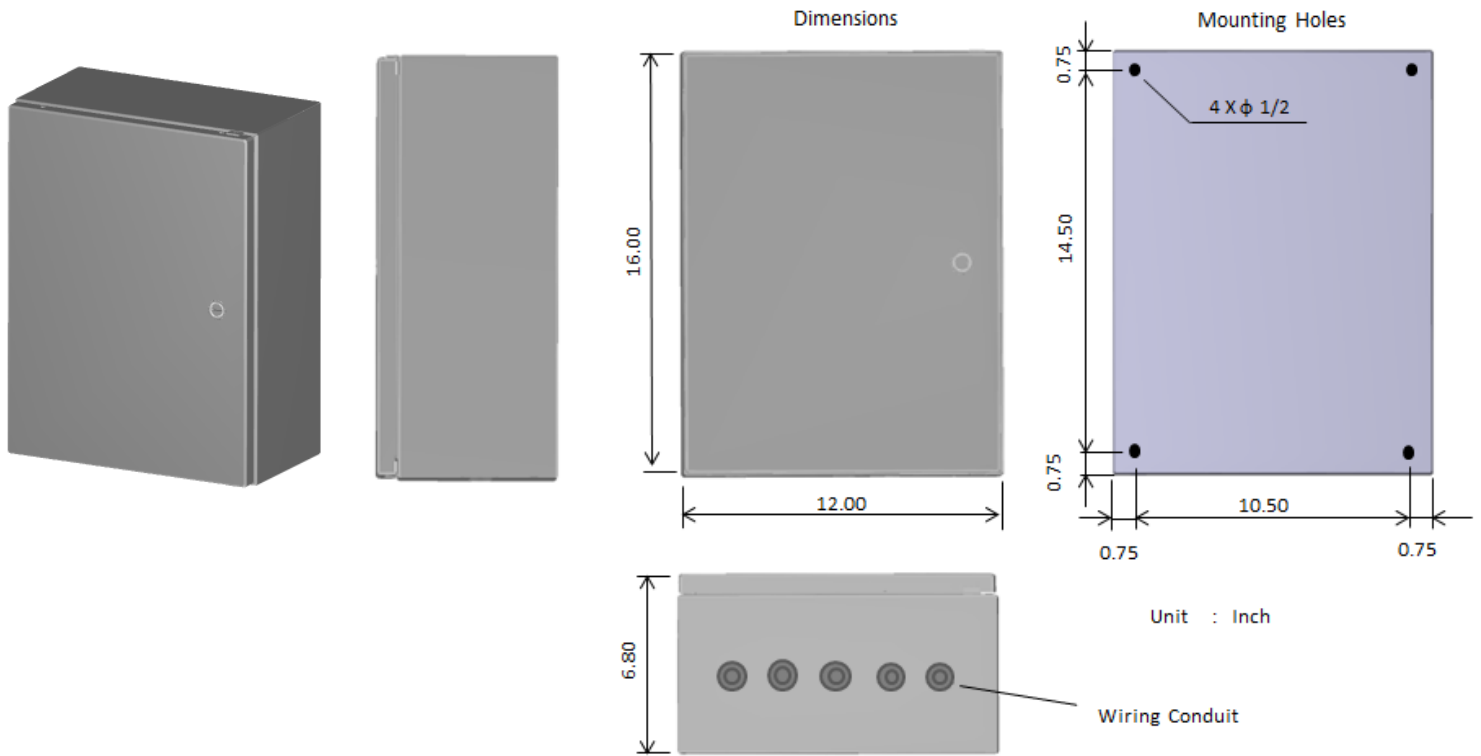

■ Refrigerant piping design

•Piping size

Outdoor unit	Gas side	Liquid side
072 type, 096 type	Φ7/8"	Φ1/2"

•Allowable piping length

Description	Allowable value
Furthest equivalent pipe length	230ft
Maximum real length between Dx-PMV kit and 3 rd party coil	16ft
Maximum height difference between outdoor unit and 3 rd party coil	66ft

Be sure to follow the instruction of outdoor units for piping work and additional refrigerant charge.

■ VRF DX Coil Schematic and coil preparation

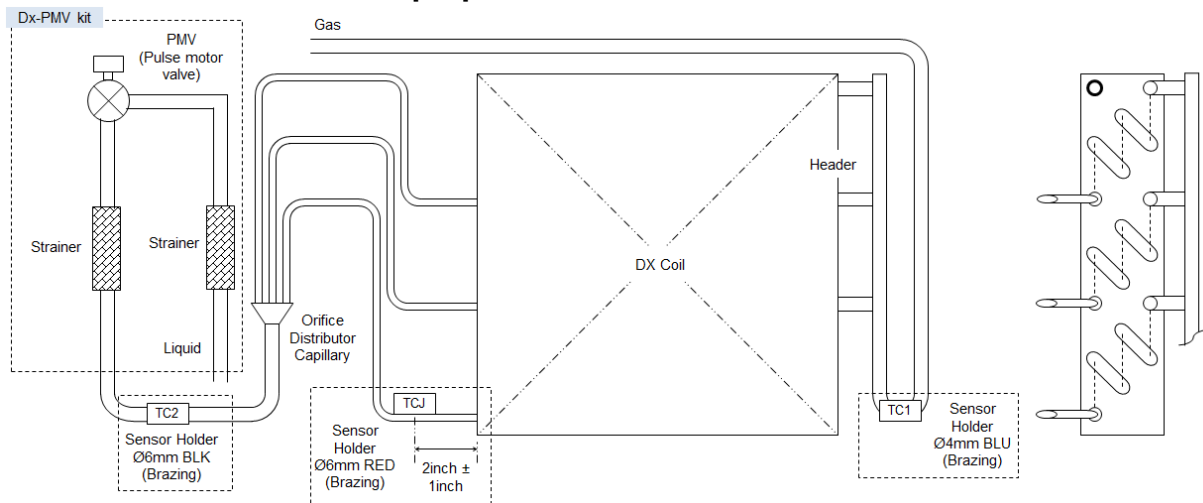

The Dx-PMV kit (RBM-A0601GUL/RBM-A0961GUL) is necessary as a separate products. These will need to be assembled and then fitted to Dx-Coil. This is a custom process as each Dx-Coil will be different, time and care should be given to this activity, and it should be prepared off-site.

The 3rd Party Dx-Coil should be supplied with a Gas Header and Liquid Capillary Distributor (see below):-

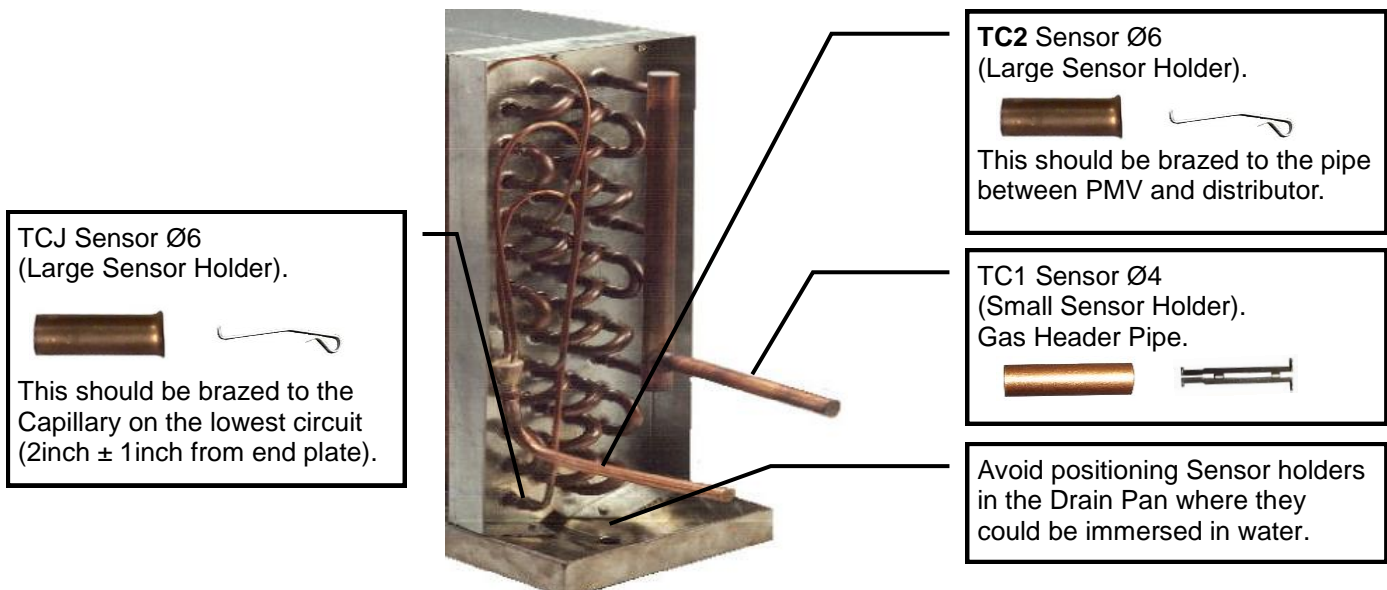

■ Dx-PMV kit

Dx-PMV kit (RBM-A0601GUL / RBM-A0961GUL) should be connected in liquid pipe line between outdoor unit and 3rd party coil. Please refer to the installation manual of Dx-PMV kit.

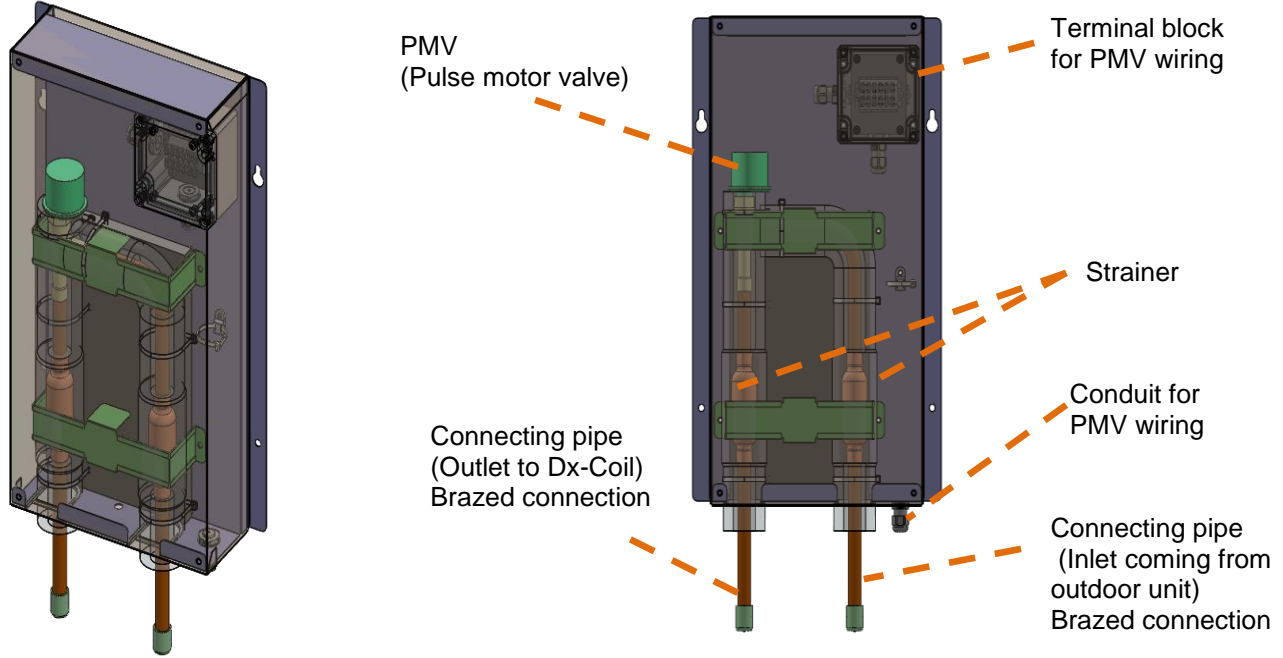

NOTES

Cautions when Brazing Dx-PMV kit

- A) Whilst brazing, the PMV body and PMV head must be cooled to keep the component's temperature below 212°F.
- B) Whilst brazing, nitrogen gas must be flowed through the PMV valve and pipework to prevent internal oxidization.
- C) Prevent cooling water from getting inside the PMV valve and connector of the lead during brazing.
- D) Take care not to damage the PMV cables during brazing.

■ TA SENSOR



Secure this sensor using the supplied plastic clamp. It must be located before the DX-Coil after pre-conditioning (Air to Air Heat exchanger / Return Air Mixing / Auxiliary Heating or Cooling). Ensure that the Resin Sensor bulb is not covered by the protective vinyl-tube.

Installer must procure the extension field wire compliant to NFPA70/NEC for local cables to connect temperature sensor and to connect the terminal block as necessary.

6 ELECTRICAL WORK

WARNING

- **Using the specified wires, ensure to connect the wires, and fix wires securely so that the external tension to the wires does not affect the connecting part of the terminals.**
Incomplete connection or fixation may cause a fire, etc.
- **Be sure to connect earth wire (grounding work).**
Incomplete grounding causes an electric shock.
Do not connect ground wires to gas pipes, water pipes, lightning rods or ground wires for telephone wires.
- **Appliance shall be installed in accordance with national wiring regulations.**
Capacity shortage of power circuit or incomplete installation may cause an electric shock or a fire.

CAUTION

- If incorrect / incomplete wiring is carried out, it will cause an electrical fire or smoke.
- Be sure to install an earth leakage breaker that is not tripped by shock waves.
If an earth leakage breaker is not installed, an electric shock may be caused.
- Be sure to use the cord clamps attached to the product.
- Do not damage or scratch the conductive core and inner insulator of power and inter-connecting wires when peeling them.
- Use the power cord and inter-connecting wire of specified thickness, type and protective devices required
- Never connect 208/230V power to the terminal blocks (U1/U2, A/B, etc) for control wiring (otherwise the system will fail).

REQUIREMENT

- For power supply wiring, strictly conform to the Local Regulation for each country.
- For wiring of power supply of the outdoor units, follow the Installation manual of each outdoor unit.
- Perform the electric wiring so that it does not come in to contact with the high-temperature part of the pipe. The coating may melt in an accident.
- Be sure remove the gland plate from the Dx-Controller when drilling gland holes. Use cable glands when installing wires through the gland plate of the Dx-Controller.
- Run the refrigerant piping and control wiring line in the same line.
- Do not turn on the power of the Dx-Controller until vacuuming of the refrigerant pipes completes.

■ Power supply wire and communication wires specifications

Power supply wire and communication wires are procured locally.

For the power supply specifications, follow to the table below. If capacity is little, it is dangerous because overheat or seizure may be caused.

For specifications of the power capacity of the outdoor unit and the power supply wires, refer to the Installation manual attached to the outdoor unit.

Cable size must be calculated for site condition and correct glands fitted. All cables should be in conduit or armoured cables correctly glanded. This has to be done by the site installer.

DX CONTROLLER power supply

- For the power supply of the Dx-Controller, prepare the exclusive power supply separated from that of the outdoor unit.
- Arrange the power supply, earth leakage breaker and main switch of the Dx-Controller connected to the same outdoor unit so that they are commonly used.

▼ Power supply

Power supply	208 / 230V 1ph 60Hz	
Power supply switch / Earth leakage breaker or power supply wirings / fuse rating for Dx-Controller.	CONTROLLERS should be selected by the accumulated total current values of the Dx-Controller.	
Power supply wiring	Up to 164'1" (50m)	MCA : 0.4A, MOCP : 15A

Control wiring, Central controller wiring

- 2-core with polarity wires are used for the Control wiring between indoor and outdoor unit and Central controller wiring.
- To prevent noise trouble, use 2-core shield wire.
- The length of the communication line means the total length of the inter-unit wire length between indoor and outdoor units added with the central control system wire length.

▼ VRF Communication Line (U1/U2)

VRF Control wiring between DX-Controller and outdoor unit (2-core shield wire)	Wire Size	(Up to 3280'10" (1000m)) AWG16 (Up to 6561'8" (2000m)) AWG14
Central control wiring (2-core shield wire)	Wire Size	(Up to 3280'10" (1000m)) AWG16 (Up to 6561'8" (2000m)) AWG14

▼ VRF Remote control wiring (A/B)

- 2-core with non-polarity wire is used for wiring of the remote control wiring.

Remote control wiring.	Wire size: AWG20
Total wire length of remote control wiring	Up to 1640'5" (500m)

▼ PMV (Pulse motor wiring (6 wire))

PMV wiring.	Wire size: AWG20 to 22
-------------	------------------------

⚠ CAUTION

The remote controller wire (communication line) and AC208/230V wires cannot be parallel to contact each other and cannot be stored in the same conduits. If doing so, a trouble may be caused on the control system due to noise, etc.

■ Remote control wiring (Optional)

- As the remote controller wire has non-polarity, there is no problem if connections to Dx-Controller terminal blocks A and B are reversed.

▼ Wiring diagram

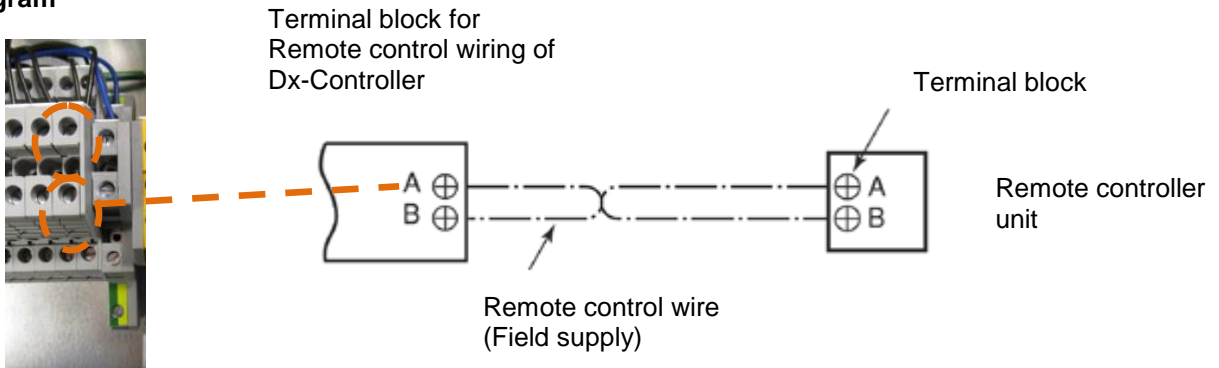

■ Wiring between Dx-Controller and outdoor unit

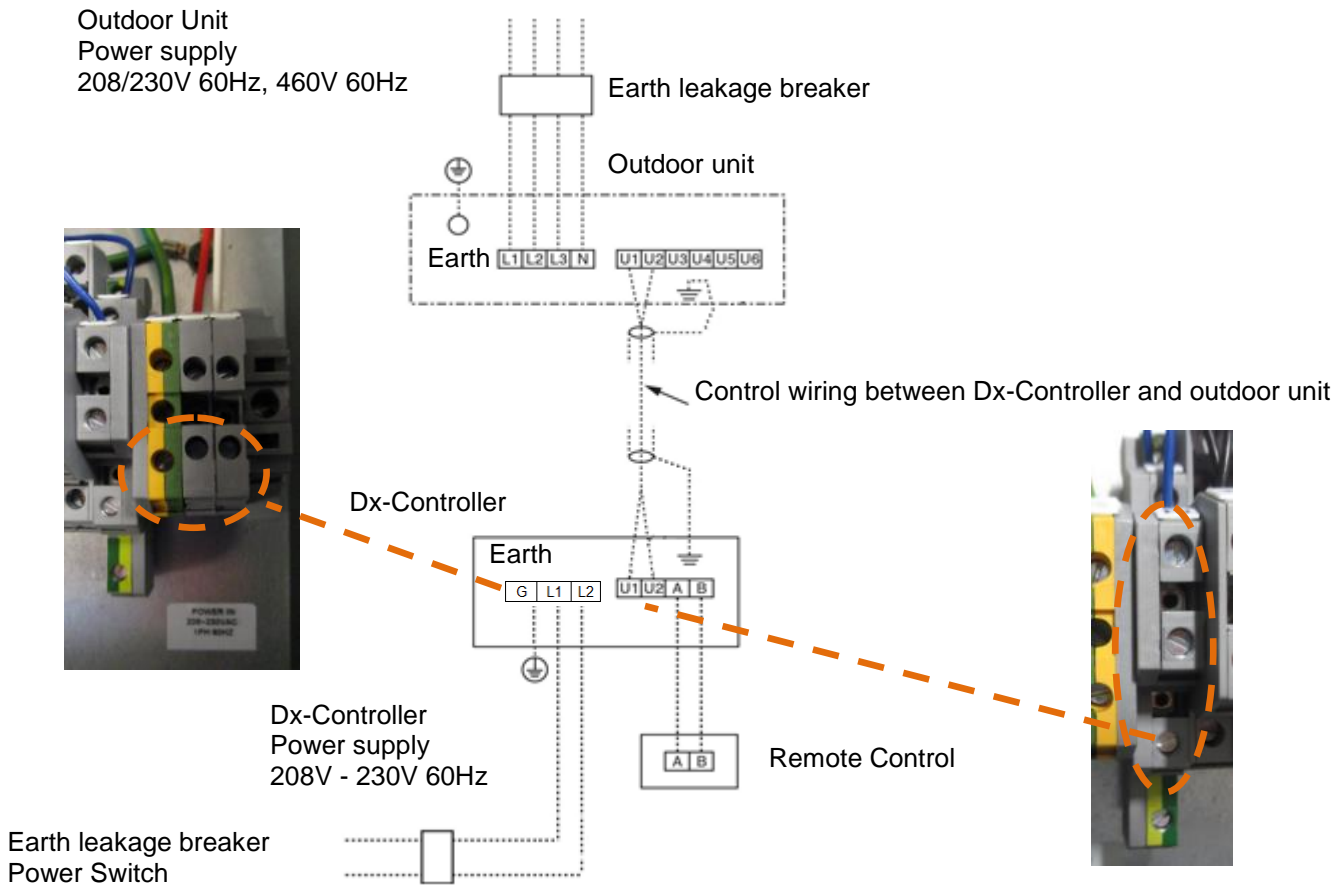

■ VRF Address Set Up

Set up the addresses as per the Installation manual supplied with the outdoor unit.

■ Electrical Connections (TCB-IFDD1GUL)

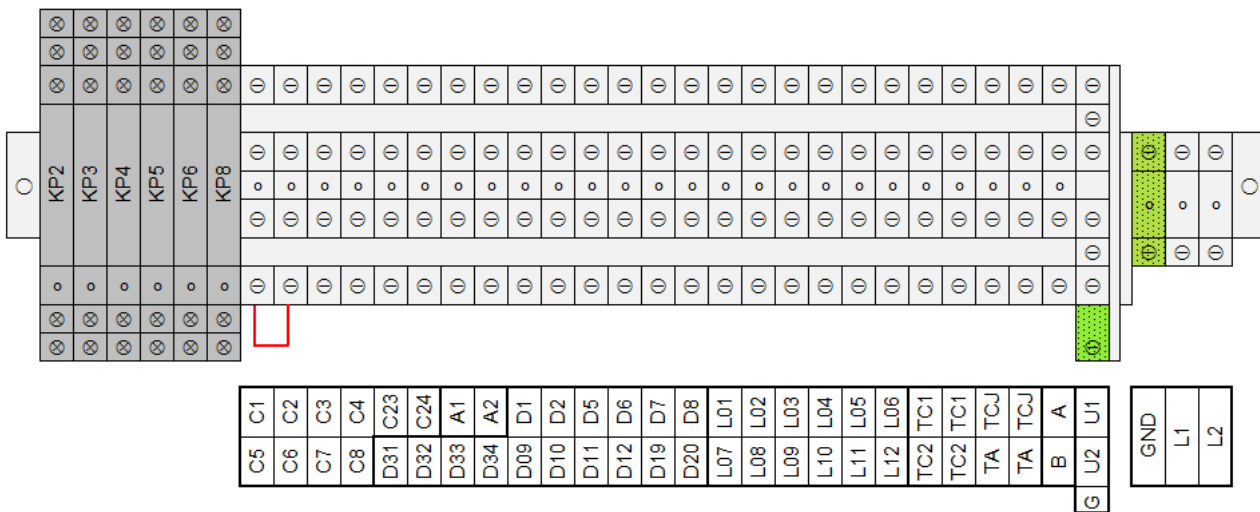

■ Summary of BMS Inputs and Outputs

Description	Type	Terminal
VRF Power Supply	230 VAC	G & L1 & L2
Capacity Demand Input	AI (0-10V)	A1 & A2
ON / OFF input	DI	C1 & C2
Mode (Heat / Cool) Input	DI	C23 & C24
Capacity lower than Capacity Demand	DO	D31 & D32 (SW1_0) / D33 & D34 (SW2_0)
Capacity higher than Capacity Demand	DO	D31 & D32 (SW1_1) / D33 & D34 (SW2_1)
VRF Cooling Oil Recovery / Heating refrigerant recovery control	DO	D31 & D32 (SW1_2) / D33 & D34 (SW2_2)
Heating Mode Active	DO	D31 & D32 (SW1_3) / D31 & D32 (SW2_3)
Cooling Mode Active	DO	D31 & D32 (SW1_4) / D31 & D32 (SW2_4)
Sub-Bus (AB) : Remote controller wiring	Serial	A & B
VRF / Central Control (U1/U2)	Serial	U1 & U2 & G
Safety contact input (P10)	DI (NC)	C5 & C6
Fan error input (L30)	DI	C7 & C8
Fan Operation (Contact Rating: 250VAC 6A)	DO	D1 & D2 (KP2)
Alarm output (Contact Rating: 250VAC 6A)	DO	D5 & D6 (KP3)
Defrost output (Contact Rating: 250VAC 6A)	DO	D7 & D8 (KP4)
VRF Start-up Control (Contact Rating: 250VAC 6A)	DO	D9 & D10 (KP5)
Pre-Defrost Active (Contact Rating: 250VAC 6A)	DO	D11 & D12 (KP6)
Thermo ON (NC) output (Contact Rating : 250VAC 6A)	DO	D19 & D20 (KP8)

VRF: Supply

Terminal G & L1 & L2. The Dx-Controller should be connected to the main power supply by means of a switch with a contact separation of at least 0.12inch. (Note : Impulse voltage : 1500V 3 minutes)

Analogue Input 1 (0-10V Capacity Control)

Terminal A1 & A2. See BMS section for details.

Digital Input 1 (ON / OFF)

Terminal C1 & C2. ON / OFF over a dry contact. If the contact is closed, the system switches on. If the contact is opened, the system switches off. If the system is switched using the external contact, then switching ON / OFF using the remote control is still possible. Note that an appropriate capacity control demand (AI_1) is additionally required for the system to start.

Digital Input 2 (Mode)

Terminal C23 & C24. HEAT / COOL mode selection over a dry contact. If the contact is closed, the system changes to HEAT mode. If the contact is opened, the system changes to COOL mode. Mode changes can also be made using a wired remote controller (if fitted). Note only COOL mode and HEAT mode are available.

Digital Output 1 (User Defined)

Terminal D31 & D32. See BMS section for details.

Digital Output 2 (User Defined)

Terminal D33 & D34. See BMS section for details.

Remote control BUS line (A / B)

Terminal A & B At these terminals an optional wired remote control can be attached (useful for installation and maintenance).

VRF: Inside device BUS line (U1 / U2 / G)

Terminal U1 & U2 & G Details regarding the wiring of the Central Control BUS can be found in the installation manual of the VRF outdoor unit.

External safety Input

Terminal C7 & C8 If this contact is open for more than 1 minute, the error message P10 is generated and the ventilation kit switches off automatically (Rating 12VDC). This contact can, for instance, be used with an on-site frost protection monitor.

If the External safety contact is not used, then the contact should be bridged.

Fan Error Input

Terminal C7 & C8. An operation monitor (supplied locally) of the Air Flow is to be attached at this terminal as a dry contact (for instance, differential pressure monitor, vane relay or similar). A closed contact generates the error message L30.

Safety Input

Terminal C5 & C6. Factory setting is "CLOSED". This can be used as safety lock by external signal on 3rd party system. If this contact is "OPEN", system stops and generates the error code message P10.

Fan Operation Output

Terminal D1 & D2 (KP2). During Fan Motor operation, this signal is active..

Alarm signal Output

Terminal D5 & D6 (KP3). During Alarm status, this signal is active.

Defrost Operation Output

Terminal D7 & D8 (KP4). During Defrost operation, this signal is active.

Startup Control Output

Terminal D9 & D10 (KP5). During Start up Control, this signal is active. On Start up the VRF system overrides the 0-10V Capacity Command which can lasts for up to 20minutes.

Pre-Defrost Signal Output

Terminal D11 & D12 (KP6). At five minutes before the scheduled start of a Defrost, this signal is active.

Thermo-ON Signal Output

Terminal D19 & D20 (KP6). During thermos-ON status, this is active.

VRF: Temperature sensors

The refrigerant temperature sensors are inserted into the brazed sensor holders (There are 2 sizes of refrigerant Sensors: Ø4 & Ø6) and secured using the supplied SENSOR FIX-PLATE (There are 2 sizes of FIX-PLATE).

The sensor cables are to be attached as follows:

TC2/TC2	TC2 Sensor Ø6 (BLK Plug / BLK Vinyl Tube)	Field Fitted to DX-Controller
TCJ/TCJ	TCJ Sensor Ø6 (RED Plug / RED Vinyl Tube)	Field Fitted to DX-Controller
TA/TA	TA Sensor Resin (YEL Plug / BLK Vinyl Tube)	Field Fitted to DX-Controller
TC1/TC1	TC1 Sensor Ø4 (BRN Plug / BLU Vinyl Tube)	Field Fitted to DX-Controller

VRF: Pulse modulation valve (PMV)

The PMV connecting is as follows:

L01/L02/L03/L04/L05/L06	PMV1 wiring	Connecting to Dx-PMV kit (RBM-A0601/0961GUL)
L07/L08/L09/L10/L11/L12	PMV2 wiring (Not used)	

Maximum wire length of PMV wiring is 16ft. TCB-IFFDD1GUL use PMV1 only. Do not connect PMV2 port.

•PMV (Pulse motor valve) wiring

PMV wiring connection from Dx-Controller to Dx-PMV kit is as follows.

Terminal number		Colour	RBM- A0601GUL A0961GUL
PMV1	PMV2		
L01	Not used	RED	✓
L02		BRN	✓
L03		WHI	✓
L04		YEL	✓
L05		ORG	✓
L06		BLU	✓

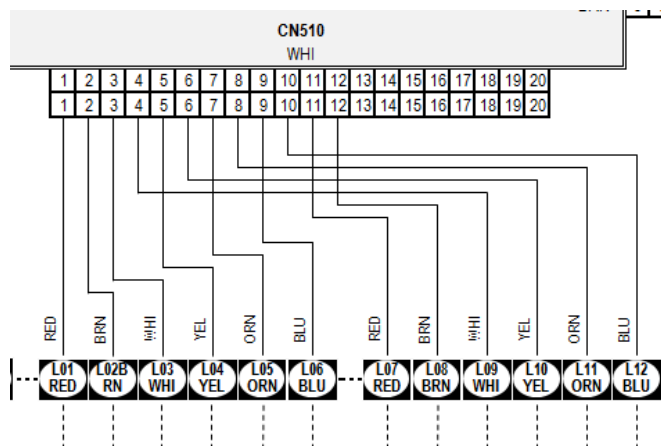

7 APPLICABLE CONTROLS / BMS INTEGRATION

A wired remote control is required during installation of the 0-10V Dx-Controller.

The 0-10V PCB communicates on the A/B BUS, it is configured as a HEADER remote controller. In order to use a wired remote controller for installation and maintenance purposes the wired remote controller MUST be configured to be a FOLLOWER remote controller otherwise you will get Alarm Check Code E09.

■ Dx-Controller Configuration



- The Dx-Controller (TCB-IFDD1GUL) main PCB is common for RA control (Return air temperature control) and 0-10V.
- As default this is configured as a 0-10V in this model. Do not change the DIP-SW501 on MCC-1570.

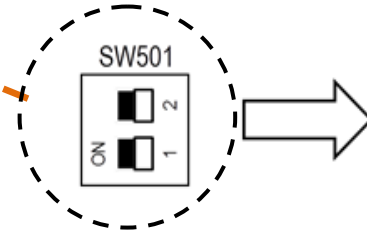

System	RA control	0-10V
SW501_1	OFF	OFF
SW501_2	OFF	ON

REQUIREMENT

- When you use this air conditioner for the first time, it takes approx. 5 minutes until the remote control becomes available after power-on. This is normal.

<When the power is turned on for the first time after installation>
It takes **approx. 5 minutes** until the remote control becomes available.

<When the power is turned on for the second (or later) time>
It takes **approx. 1 minute** until the remote control becomes available.

- Normal settings were made when the unit was shipped from factory. Change the Dx-Controller as required.
- Use the wired remote control to change the settings.
- The settings cannot be changed using the wireless remote control, sub remote control, or remote control-less system (for central remote control only). Therefore, install the wired remote control to change the settings.

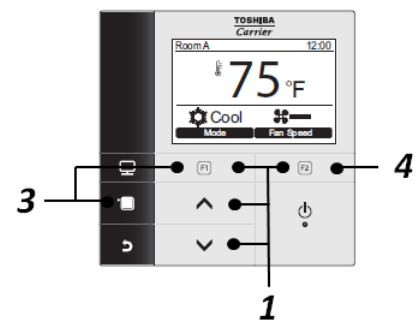
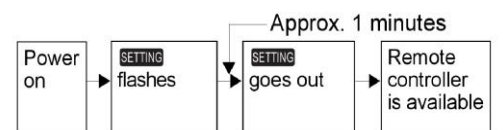
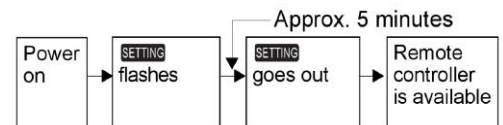

■ Changing of settings for applicable controls

Basic procedure for changing settings

Change the settings while the air conditioner is not working.
(Be sure to stop the air conditioner before making settings).

Procedure 1

Push the [▲ ▲]/[▼ ▼] button to select "7. DN setting" on the "Field setting menu" screen, then push "Set" [F2] button.
Move the cursor to select "DN code" with the "<" [F1] button, then set "DN code" with the [▲ ▲]/[▼ ▼] button.
Move the cursor to select "data" with the ">" [F2] button, then set "data" with the [▲ ▲]/[▼ ▼] button.

Procedure 2

Refer to this installation manual for details about the DN code and data.

Procedure 3

Push the [MENU] button to set the other DN codes. After "Continue?" is displayed on the screen, push the "Yes" [F1] button

Procedure 4

Push the "No" [F2] button to finish the setting operation. "⌚" appears on the screen for a while, then the screen return to the "Field setting menu" screen.

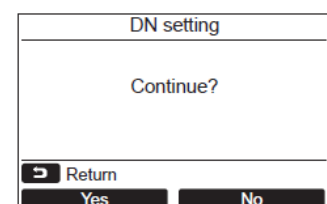
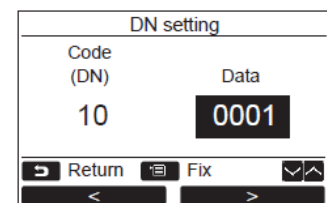
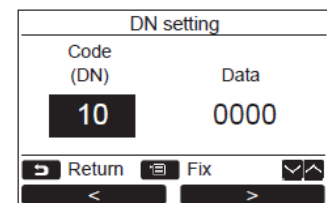

■ Device Type / Capacity DN Code setting (Requires wired Remote Control)



- Follow the basic operation Procedure (1 → 2 → 3 → 4) outlined above.
- The interface uses a new Device Type DN Code 10_55. This is set at the factory.
- The installer must set Capacity Code (DN Code 11). As default this is configured as a 10HP model at the factory (DN 10_23). See the following table.

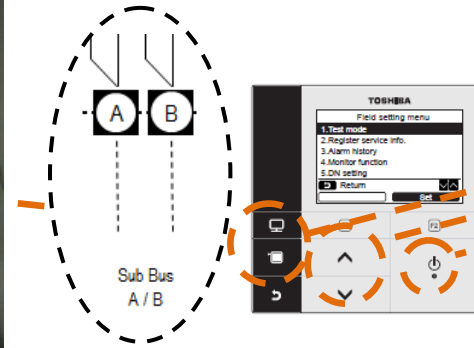

<How to enter the DN setting>

1. Push the [MENU] button to display the menu screen.
2. Push and hold the [MENU] and [V V] button at the same time for more than 4 seconds to display the "Field setting menu".
3. Select "7. DN setting" on the "Field setting menu", then push the [F2] button to set.

Capacity (Ton)	5	6	8
Capacity Code (DN 11)	18	21	23
VRF (RBM-A****GUL)	0601	0961	0961

■ Main Indoor PCB (MCC-1570): CN60/CN61/CN82 Configuration

- Digital output functions are available from CN60/CN61/CN82 connector on the main PCB (MCC-1570) inside Dx-Controller.
- For ease of installation connection to the CN60/CN61/CN82 outputs are made on the relays included in the Dx-Controller.



Output	Output Function	Relay Number
CN60.1+2	Defrost output	KP4
CN60.1+3	Cooling / Heating start up control	KP5
CN60.1+4	Pre-defrost output (static or pulse)	KP6
CN60.1+6	Fan operation output	KP2
CN61.5+6	Alarm output	KP3
CN82.6+3	Thermo-ON output	KP8

■ MS Specification: 0~10V PCB

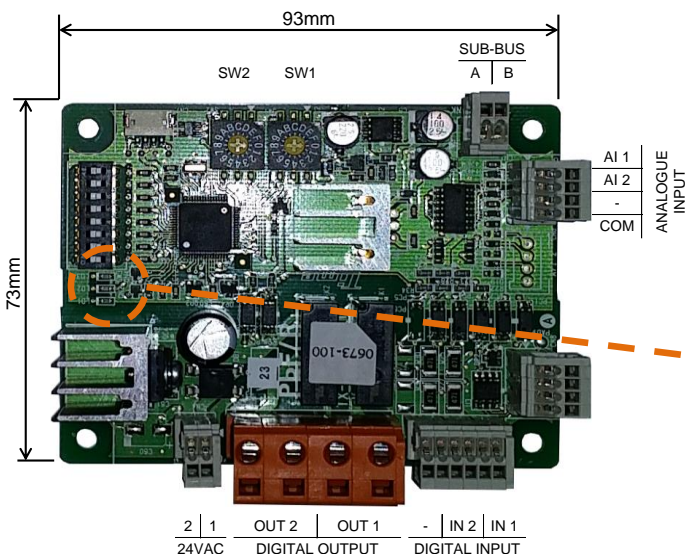

Function	Description
Power supply	Sub bus connection (A/B): 15V ~ 24VDC 24VAC (supplied from Dx-Controller)
LED display	LD1 (GRN ON): Power Supply OK LD3 (RED FLASH): Communication Error LD3 (RED ON): Alarm Active

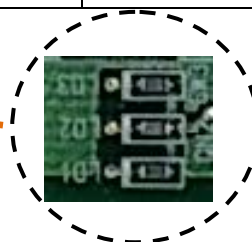

Function	Terminal	Max. Cable Length (ft)	Cable Specification
Analogue input	A1 & A2	656ft	Screened cable: AWG16 to 20
Digital input	C1 & C2 / C23 & C24	328ft	Non screened cable: AWG16 to 20
Digital output	D31 & D32 / D33 & D34	1640ft	Non screened cable: AWG16 to 20

■ BMS Specification: Analogue Input 1

- 1: AI 1 = Capacity control
- 2: - = Not Used
- 3: - = Not Used
- 4: COM = Common

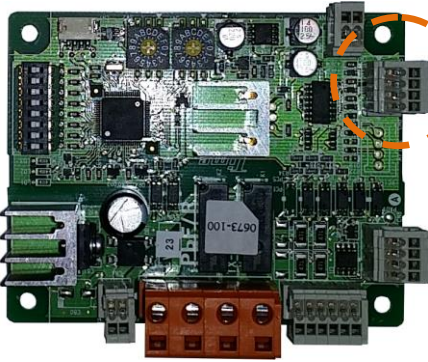

* Be sure NOT to input more than DC10V in analogue input terminal

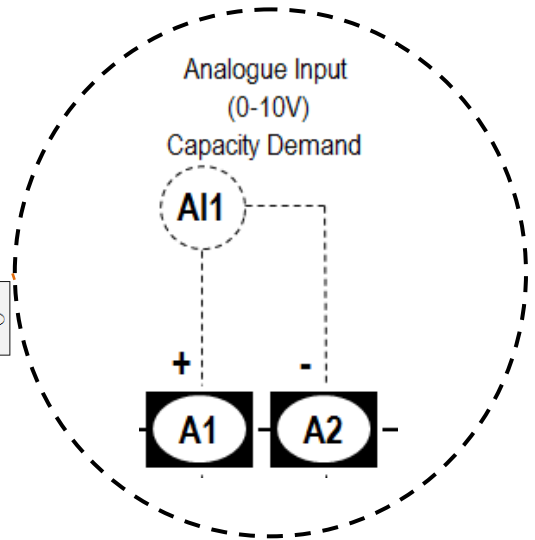
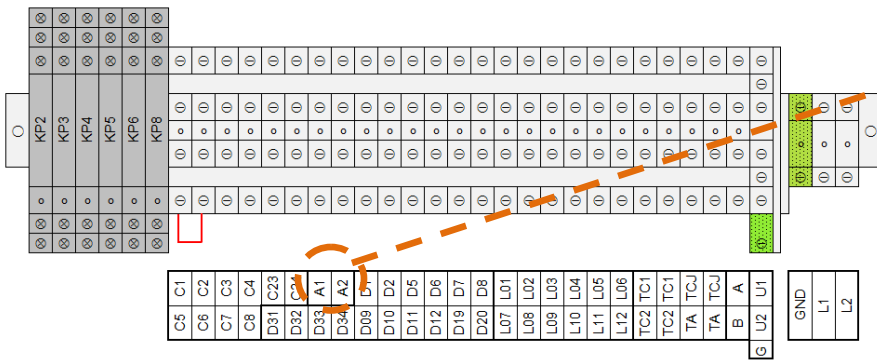

- To ease the integration of the Dx-Interface with the AHU DDC the capacity control is able to operate with a STEPPED or LINEAR function from the analogue input.
- To select either a STEPPED (default) or LINEAR response, from the analogue input, use DIP-SW03 located on the 0~10V IF PCB.

DIP-SW03_2	Function
OFF	STEP response to analogue input
ON	LINEAR response to analogue input

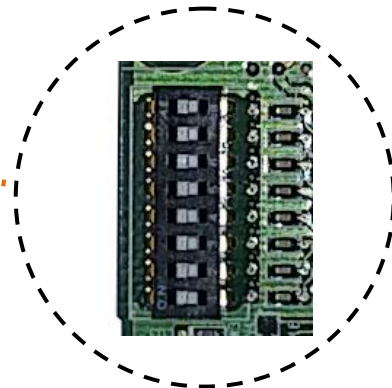
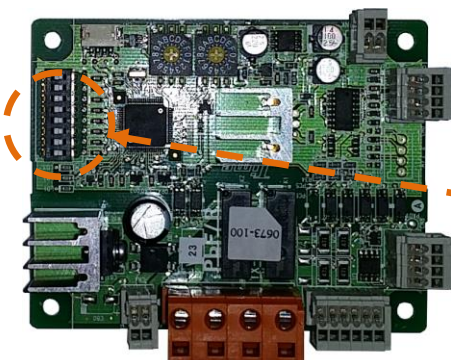

■ AI_1 Demand 0~10V Stepped Control (SW3_2 OFF – Default)

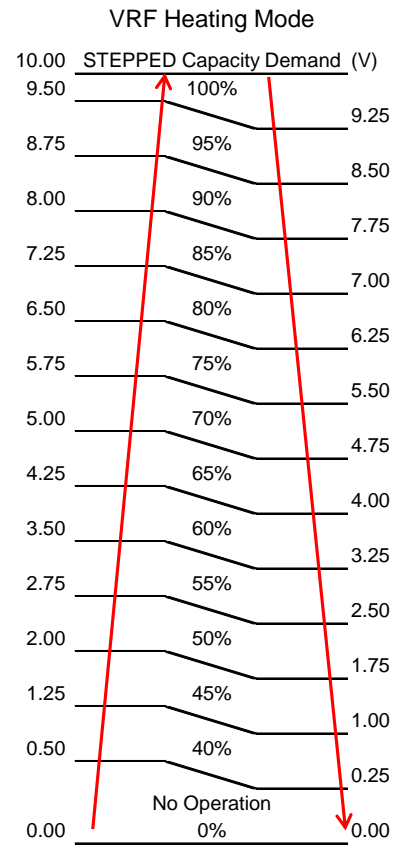
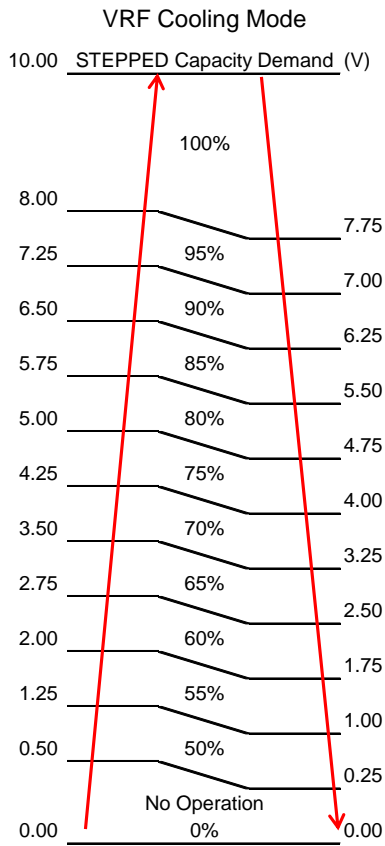

■ AI_1 Demand 0~10V Linear Control (SW3_2 ON)

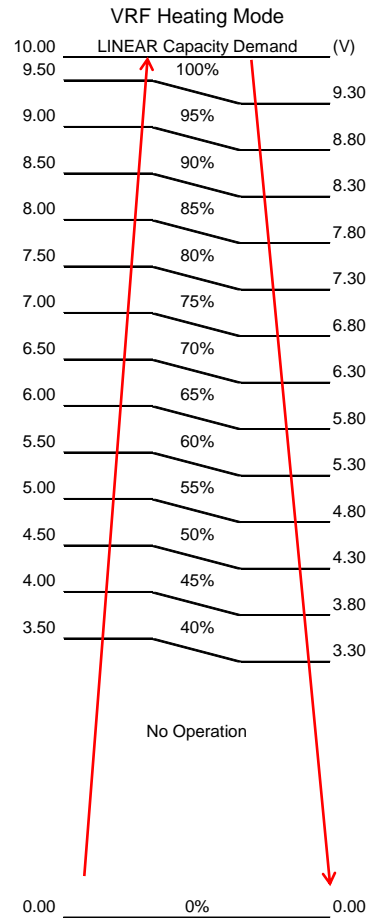
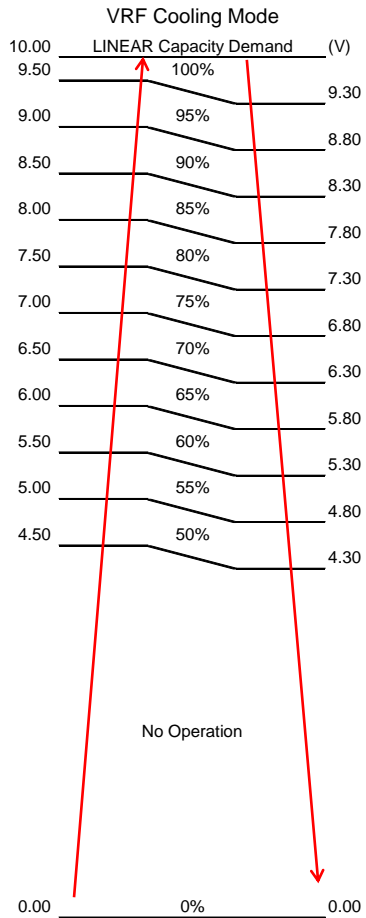

■BMS Specification: Digital Inputs

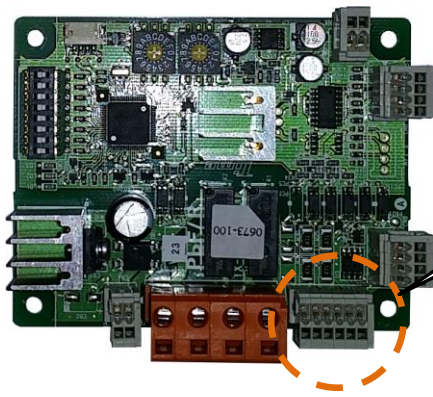

1 & 2: NOT USED
3 & 4: DIGITAL INPUT 2
5 & 6: NOT USED

Locally supplied no volt
dry contact required to
enable digital inputs

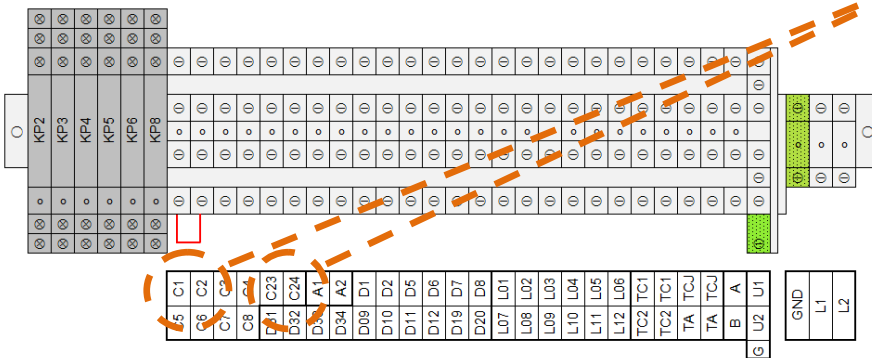
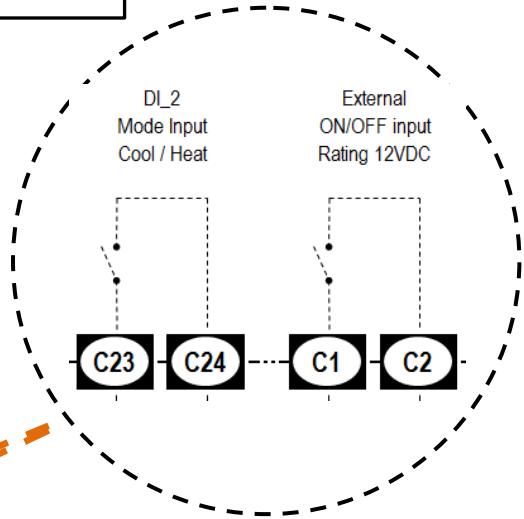

Function	DI OPEN	DI SHORT
External ON/OFF	Operation OFF	Operation ON
DI2	COOL mode active	HEAT mode active

- Digital Input terminal supply voltage (12VDC) from PCB.

■ BMS Specification: Digital Outputs

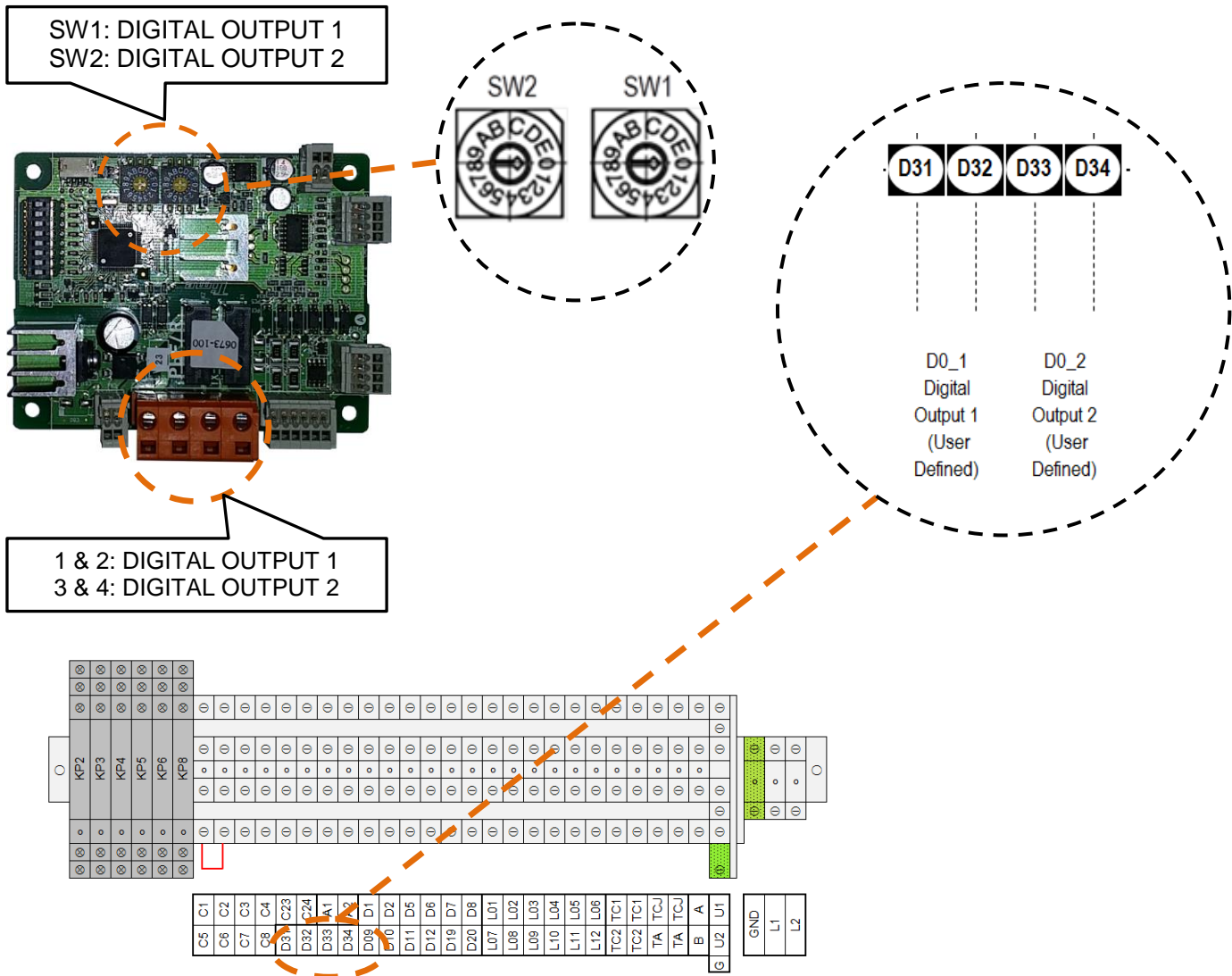

Output function selected using rotary switches on PCB

Rotary Sw. Position	Output Function
0	Lower than capacity command
1	Higher than capacity demand
2	Cooling oil recovery control / heating refrigerant recovery control
3	Cooling output
4	Heating output
5	Thermo-ON output
6 ~ F	No Function (for future use)
Relay contact rating	250VAC: 5A (max) 30VDC: 5A (max)

■ Digital input / output function (MCC-1570)

Connector	Pin	Function	Remarks	Standard / Option	Relay
CN32 (WHI)	1	DC12V (COM)		-	
	2	Output	Ventilation control	Option	
CN34 (RED)	1	COM (DC12V)		-	
	2			-	
	3	External safety contact	Error code P10, Normal close	Standard	
CN60 (WHI)	1	DC12V (COM)		-	
	2	Defrosting output	ON while outdoor unit defrosted	Standard	KP4
	3	Start up control output	Signal output during cooling/heating start up control	Standard	KP5
	4	Pre-defrost output	Signal output before defrosting	Standard	KP6
	5	Operation mode output	Cooling : Open, Heating : Close	Option	
	6	Fan output	ON while fan ON	Standard	KP2
CN61 (YEL)	1	ON/OFF input	Start/Stop input	Standard	
	2	0V (COM) for pin 1, 3		-	
	3	Remote control disabling input	Enables/Disables start/stop control via remote controller	Option	
	4	In operation output	ON during operation	Option	
	5	DC12V (COM) for pin 4, 6			
	6	Alarm output	ON while alarm ON	Standard	KP3
CN70 (WHI)	1	Option	Option error input	Option	
	2	0V (COM)		-	
CN73 (RED)	1	Demand input	Forced thermos-off input	Option	
	2	0V (COM)		-	
CN80 (GRN)	1	COM(DC12V)		-	
	2	COM (DC12V)		-	
	3	External error input	Error input from outside (Interlock, error code L30)	Standard	
CN82 (BLU)	1	Heating output		Option	
	2	Fan active output		Option	
	3	Thermo-ON output	Signal output during thermo-ON	Standard	KP8
	4	Cooling output		Option	
	5	DC12V (COM)		-	
	6	DC12V (COM)		-	
CN510 (WHI)	1	PMV1 12V DC		Standard	
	2	PMV1 12V DC		Standard	
	3	PMV1 output A		Standard	
	4	PMV2 output A	Not used	Standard	
	5	PMV1 output B		Standard	
	6	PMV2 output B	Not used	Standard	
	7	PMV1 output /A		Standard	
	8	PMV2 output /A	Not used	Standard	
	9	PMV1 output /B		Standard	
	10	PMV2 output /B	Not used	Standard	
	11	PMV2 12VDC	Not used	Standard	
	12	PMV2 12VDC	Not used	Standard	
	13-20		No function	-	

8 TEST RUN

■ Preparation

- Before turning on the power supply, carry out the following procedure.
 - 1) Using 500V-Megger, check that the resistance of 1MΩ or more exists between the terminal block of the power supply and the earth (grounding).
If resistance of less than 1MΩ is detected, do not run the unit.
 - 2) Check the valve of the outdoor unit being opened fully.
- To protect the compressor at activation time, leave power-ON for 12 hours or more before operating.
- Never press the electromagnetic contactor to forcibly perform the test run. (This is very dangerous because the protective device does not work).
- Before starting a test run, be sure to set addresses following the installation manual supplied with the outdoor unit.

■ How to execute a test run

Using the BMS inputs, operate the unit as usual. Analogue Input 1 (AI1) must be set to a voltage greater than 0.5V (4.5V recommended) when using the STEPPED function (DIP-SW03_2 OFF) or greater than 2.3V when using the LINEAR function (DIP-SW03_2 ON). If AI1 is set to 0V the Test function will not operate

Alternatively (using a wired remote control) a forced test run can be executed in the following procedure even if the operation stops by thermo-OFF.

In order to prevent a serial operation, the forced test run is released after 60 minutes have passed and returns to the usual operation.

⚠ CAUTION

- Do not use the forced test run for cases other than the test run because it applies excessive load to the devices.

In case of wired remote control.

Procedure 1

Push the [▲ ▲]/[▼ ▼] button to select “1. Test mode” on the field setting menu screen, then push the “Set” [F2] button.

Pushing the “Yes” [F1] button sets the test mode and the screen returns to the field setting menu screen.

Push [▶ CANCEL] twice, the screen (2) appears.

Procedure 2

Push [▶ ON / OFF] button to start the test mode.

The screen (1) shown in the left appears.

(The screen (2) appears when the operation is stopped.)

Perform the test mode in the “Cool” or “Heat.”

Check codes are displayed as usual.

Procedure 3

When the test mode is finished, push the [▲ ▲]/[▼ ▼] button to select “1. Test Mode” on the “Field setting menu” screen, then push the “Set” [F2] button. The screen (3) appears.

Pushing the “Yes” [F1] button stops the test mode screen and continues the normal operation.

Note

The test mode stops after 60 minutes and the screen return to The normal / detailed display.

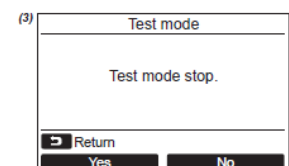
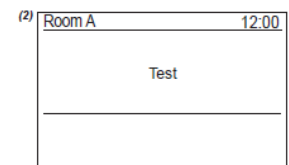
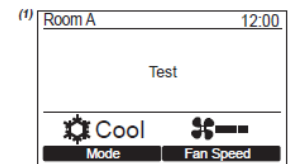
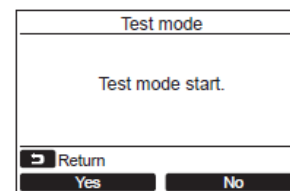
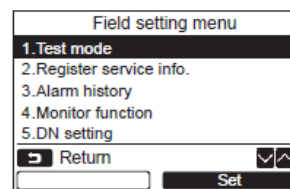
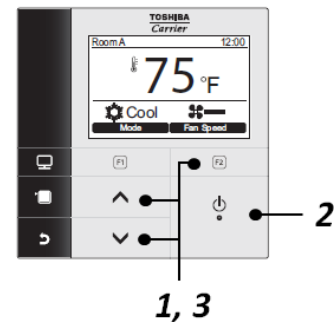

9 TROUBLE SHOOTING

■ Using Dx-Controller

In the case of a check code, the Alarm Digital output (Relay KP3, D5 / D6) is active. However a Wired Remote Control (or Central Control device) is required to read the check code number.

■ Using a wired remote control

Confirmation and Check

When a trouble occurred in the air conditioner, the check code and the Dx-Controller No. appear on the display part of the remote control.

The check code is only displayed during the operation.

Push the [MONITOR] button or [CANCEL] button to display the check information screen

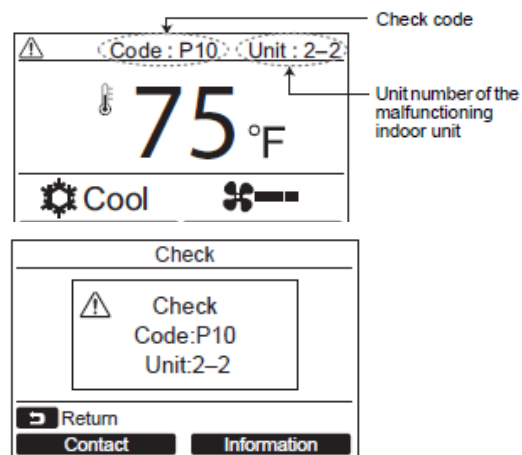

For detailed trouble shooting, refer to installation manual of outdoor units.

▼ Common Check Codes (Note the 0-10V PCB is classified as a Remote controller)

- E01 Remote control address setting error** – incorrect remote control setting. The header remote controller has not been set
- E09 Remote control address setting error** – two remote control are set as header devices in the double remote control's control
- F01 TCJ Sensor error** – Resistance value of sensor is infinite or zero. Check sensor connection / cabling.
- F02 TC2 Sensor error** – Resistance value of sensor is infinite or zero. Check sensor connection / cabling.
- F03 TC1 Sensor error** – Resistance value of sensor is infinite or zero. Check sensor connection / cabling.
- F10 TA Sensor error** – Resistance value of sensor is infinite or zero. Check sensor connection / cabling.
- E14 Communication error between the indoor PCB (MCC-1570) and the 0~10V interface PCB** – no communication between the indoor PCB and the 0~10V interface PCB for more than 3 minutes (AB connection)
- L09 DX controller capacity code incorrect** – check the settings of DN code 11 (see Device Type / Capacity DN Code setting)
- L30 External Interlock** – check the operation of C7 and C8 terminals. If this contact is “CLOSED” the error code L30 is generated
- P10 Safety contact error** – check the contact at terminals C5 and C6. If the contact is OPEN, the error code P10 is generated

■ Temperature Set Point

When a wired remote control is fitted the temperature setpoint can be changed, however this has no impact on the demand, which is controlled by the 0-10V Analogue Input.

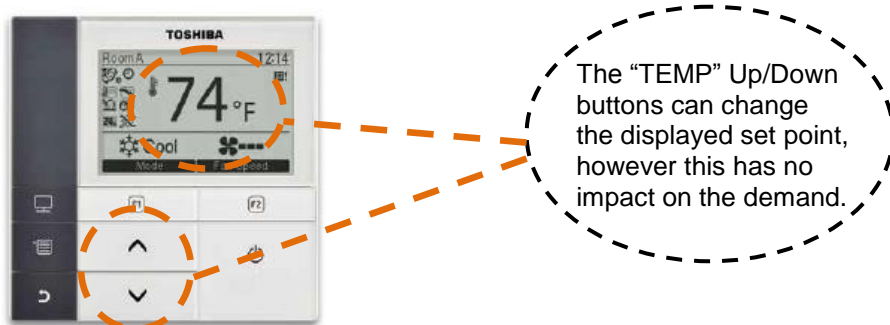

DX-Controller (0-10V type) Interface Wiring Diagram : TC8-IFDD1GUL

Notes

- The dashed lines --- indicate wiring on site.
- indicate terminal blocks and the numbers within them are the terminal numbers.
- Please refer to the installation manual for wiring instructions.
- The DX-Interface can be configured as a VRF system.
- At shipment C5 and C6 are short-circuited. Remove it when you use the terminal.

(Classification of control against electric shock : CLASS 1)

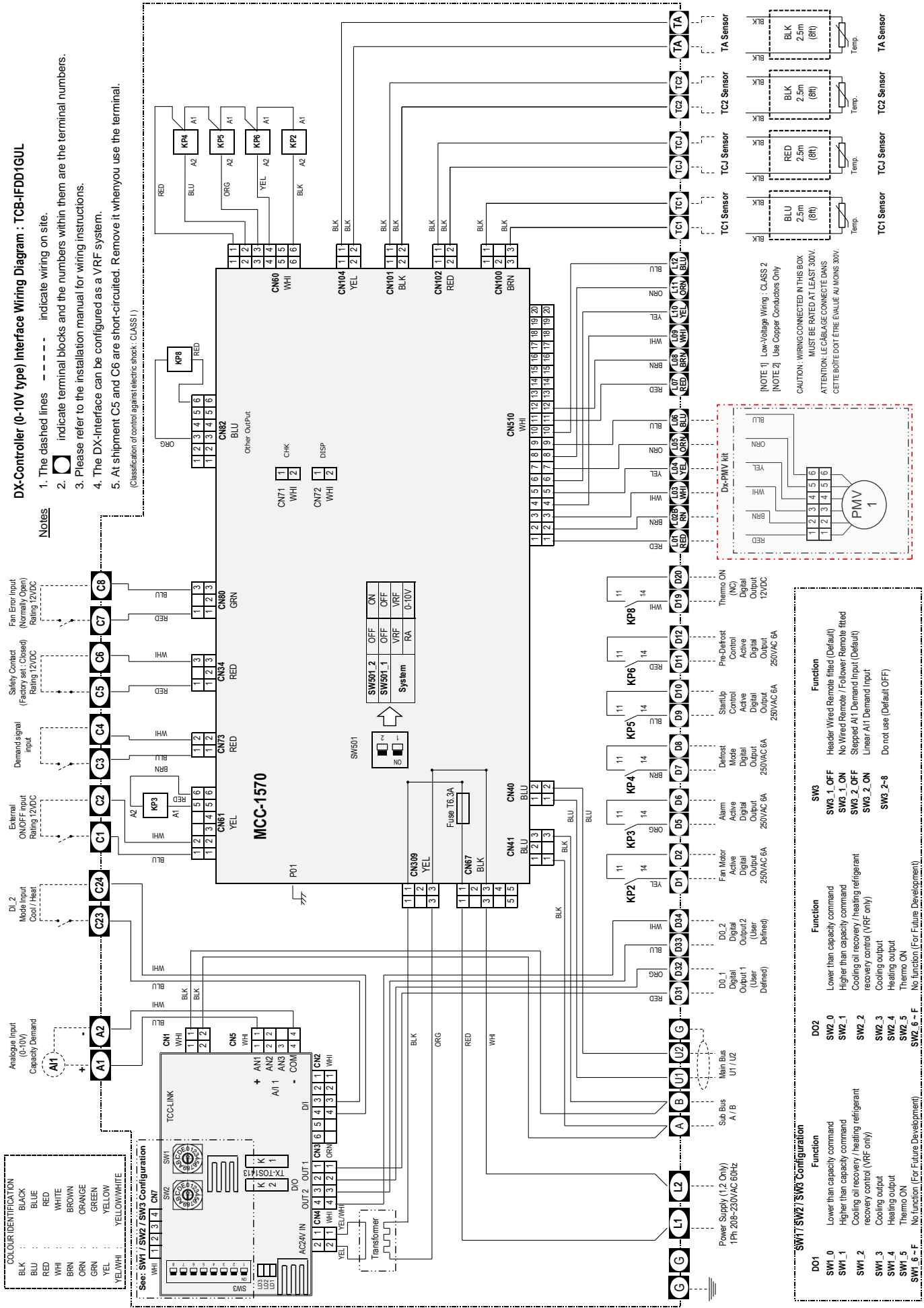

(NOTE 1) Low-Voltage Wiring : CLASS 2
 (NOTE 2) Use Copper Conductors Only
 CAUTION: WIRING CONNECTED IN THIS BOX MUST BE RATED AT LEAST 300V.
 ATTENTION: LE CÂBLAGE CONNECTÉ DANS CETTE BOÎTE DOIT ÊTRE ÉVALUÉ AU MOINS 300V.

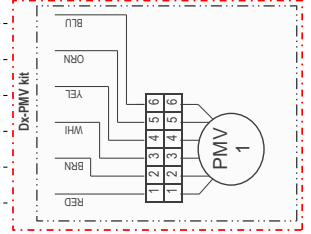

SW1 / SW2 / SW3 Configuration	Function
SW1_0	Lower than capacity command
SW1_1	Higher than capacity command
SW1_2	Cooling oil recovery / heating refrigerant recovery control (VRF only)
SW1_3	Cooling output
SW1_4	Heating output
SW1_5	Thermo ON
SW1_6	No function (For Future Development)
SW2_0	Lower than capacity command
SW2_1	Higher than capacity command
SW2_2	Cooling oil recovery / heating refrigerant recovery control (VRF only)
SW2_3	Cooling output
SW2_4	Heating output
SW2_5	Thermo ON
SW2_6	No function (For Future Development)
SW3_1_OFF	Header Wired Remote fitted (Default)
SW3_1_ON	No Wired Remote / Follower Remote fitted
SW3_2_OFF	Stepped AI1 Demand Input (Default)
SW3_2_ON	Linear AI1 Demand Input
SW3_2-8	Do not use (Default OFF)

COLOUR IDENTIFICATION	Terminal
BLK	1
BLU	2
RED	3
WHI	4
BRN	5
ORN	6
GRN	7
YEL	8
YEL/WHI	9
YELLOW/WHITE	10

See: SW1 / SW2 / SW3 Configuration

(REFERENCE) OPTIONAL PARTS

▼ Remote control (wired)

RBC-AMT32UL Wired remote control



RBC-AMS54E-UL Wired remote control



Once installed the Dx-Controller 0-10V Type does not need to have a wired Remote Control connected, however it is useful for fault finding and operation status.

▼ Central control

The Dx-Controller 0-10V Type is compatible with the range of Toshiba Central control and BMS interfaces (using U1/U2 connection):-

- Mode and ON / OFF monitoring
- Mode and ON / OFF control
- Check Code monitoring

Please note that it is not possible to monitor or control the 0-10V Analogue Input using Central Control.

Toshiba Carrier North America, Inc

1025 Cobb Place Blvd

Kennesaw

GA30144

United States

 +1-678-981-4993