

Installation Instructions

SAFETY CONSIDERATIONS

Centrifugal liquid chillers are designed to provide safe and reliable service when operated within design specifications. When operating this equipment, use good judgment and safety precautions to avoid damage to equipment and property or injury to personnel.

Be sure you understand and follow the procedures and safety precautions contained in the machine instructions as well as those listed in this guide.

▲ DANGER

DO NOT VENT refrigerant relief valves within a building. Outlet from rupture disc or relief valve must be vented outdoors in accordance with the latest edition of ASHRAE 15 (safety code for mechanical refrigeration). The accumulation of refrigerant in an enclosed space can displace oxygen and cause asphyxiation.

PROVIDE adequate ventilation in accordance with ASHRAE 15, especially for enclosed and low overhead spaces. Inhalation of high concentrations of vapor is harmful and may cause heart irregularities, unconsciousness, or death. Intentional misuse can be fatal. Vapor is heavier than air and reduces the amount of oxygen available for breathing. Product causes eye and skin irritation. Decomposition products are hazardous.

DO NOT USE OXYGEN to purge lines or to pressurize a machine for any purpose. Oxygen gas reacts violently with oil, grease, and other common substances.

NEVER EXCEED specified test pressures. VERIFY the allowable test pressure by checking the instruction literature and the design pressures on the equipment nameplate.

DO NOT VALVE OFF any safety device.

BE SURE that all pressure relief devices are properly installed and functioning before operating any machine.

▲ WARNING

DO NOT WELD OR FLAMECUT any refrigerant line or vessel until all refrigerant (*liquid and vapor*) has been removed from chiller. Traces of vapor should be displaced with dry air or nitrogen and the work area should be well ventilated. *Refrigerant in contact with an open flame produces toxic gases.*

DO NOT USE eyebolts or eyebolt holes to rig machine sections or the entire assembly.

DO NOT work on high-voltage equipment unless you are a qualified electrician.

DO NOT WORK ON electrical components, including control panels, switches, starters, or oil heater until you are sure ALL POWER IS OFF and no residual voltage can leak from capacitors or solid-state components.

LOCK OPEN AND TAG electrical circuits during servicing. IF WORK IS INTERRUPTED, confirm that all circuits are de-energized before resuming work.

DO NOT syphon refrigerant by mouth.

AVOID SPILLING liquid refrigerant on skin or getting it into the eyes. USE SAFETY GOGGLES. Wash any spills from the skin with soap and water. If any enters the eyes, IMMEDIATELY FLUSH EYES with water and consult a physician.

NEVER APPLY an open flame or live steam to a refrigerant cylinder. Dangerous overpressure can result. When necessary to heat refrigerant, use only warm (110 F [43 C]) water.

DO NOT REUSE disposable (nonreturnable) cylinders nor attempt to refill them. It is DANGEROUS AND ILLEGAL. When cylinder is emptied, evacuate remaining gas pressure, loosen the collar, and unscrew and discard the valve stem. DO NOT INCINERATE.

Operation of this equipment with refrigerants other than those cited herein should comply with ASHRAE-15 (latest edition). Contact Carrier for further information on use of this machine with other refrigerants.

DO NOT ATTEMPT to leak test using air-rich mixtures of air/HFC (or HFC) such as R-22 and R-134a. Combustibility of the mixture can occur (due to the hydrogen content of the refrigerant) when the mixture is pressurized above ambient pressure and is ignited. Non-HFC refrigerants may be safely mixed with air. Nitrogen can be used safely with R-22 trace refrigerant for leak testing.

DO NOT ATTEMPT TO REMOVE fittings, covers, etc., while machine is under pressure or while machine is running. Be sure pressure is at zero psig (zero kPa) before breaking any refrigerant connection.

CAREFULLY INSPECT all relief valves, rupture discs, and other relief devices AT LEAST ONCE A YEAR. If machine operates in a corrosive atmosphere, inspect the devices at more frequent intervals.

DO NOT ATTEMPT TO REPAIR OR RECONDITION any relief device when corrosion or build-up of foreign material (rust, dirt, scale, etc.) is found within the valve body or mechanism. Replace the valve.

DO NOT install relief devices in series or backwards.

USE CARE when working near or in line with a compressed spring. Sudden release of the spring can cause it and objects in its path to act as projectiles.

▲ CAUTION

DO NOT STEP on refrigerant lines. Broken lines can whip about and cause personal injury.

DO NOT climb over a machine. Use platform, catwalk, or staging. Follow safe practices when using ladders.

USE MECHANICAL EQUIPMENT (crane, hoist, etc.) to lift or move inspection covers or other heavy components. Even if components are light, use such equipment when there is a risk of slipping or losing your balance.

BE AWARE that certain automatic start arrangements CAN ENGAGE THE STARTER. Open the disconnect *ahead* of the starter in addition to shutting off the machine or pump.

USE only repaired or replacement parts that meet the code requirements of the original equipment.

DO NOT VENT OR DRAIN waterboxes containing industrial brines, liquid, gases, or semisolids without permission of your process control group.

DO NOT LOOSEN waterbox cover bolts until the waterbox has been completely drained.

DOUBLE-CHECK that coupling nut wrenches, dial indicators, or other items have been removed before rotating any shafts.

DO NOT LOOSEN a packing gland nut before checking that the nut has a positive thread engagement.

PERIODICALLY INSPECT all valves, fittings, and piping for corrosion, rust, leaks, or damage.

PROVIDE A DRAIN connection in the vent line near each pressure relief device to prevent a build-up of condensate or rain water.

Manufacturer reserves the right to discontinue, or change at any time, specifications or designs without notice and without incurring obligations.

List of Tables

List of Figures

Introduction

- General

- Job Data

- Equipment Required

Receiving Machine

- Inspect Shipment

- Identify Machine

- Provide Machine Protection

Rigging Equipment

- Rig Machine Assembly

- Rig Gear and Drive

- Record and Date Cooler Pressure Gage Reading

Insulation

17FA Mounting

- Isolation

- Install Couplings, Gear, and Drive

- Final Alignment

- Grout

Field Piping

- Water to Oil Cooler

- Water to Heat Exchangers

- Water to Pumpout Condenser

- Relief Devices

- Air Supply

- Piping to Turbine

- Vent and Drain Connections

- Auxiliary Connections

Field Wiring

General

Oil Heater and Thermostat

Compressor Oil Pump

Automatic Seal Oil Return Pump

Control Wiring

Pumpout Unit

Water Flow Switches

List of Tables

Table 1 — Rigging Weights

Table 2 — Condensation vs Relative Humidity

Table 3 — Insulation Requirements

Table 4 — Relief Valve Data

Table 5A — Maximum Allowable Equivalent Length of Discharge Pipe

Table 5B — Discharge Pipe Internal Area

Table 6 — Pressure Gage Location

Table 7 — Auxiliary Connections Table

List of Figures

- Figure 1 — 17FA Dimensions
- Figure 2 — 17FA Components
- Figure 3 — Compressor Components
- Figure 4 — 17FA Standard Contact Surfaces
- Figure 5 — 17FA Contact Surfaces
- Figure 6 — 17FA Piping and Wiring (Typical)
- Figure 7 — Water Piping, Oil Cooler to Chilled Water Circuit (Typical)
- Figure 8 — Typical Nozzle Piping
- Figure 9 — Field Connection to Pneumatic Thermostat
- Figure 10 — Supply Air Connection for EP Relay
- Figure 11 — Air Supply Connection to Pneumatic Guide Vane
Actuator
- Figure 12 — Oil Heater and Seal Oil Pump Wiring Schematic (Typical)
- Figure 13 — 17FA Field Wiring Terminal Strip
- Figure 14 — Control Wiring (Typical)

Contents

Figure 15 — Field Wiring (Typical)

Figure 16 — Pumpout Unit Controls

Job Data — Necessary information consists of:

- job contract or specifications
- rigging information
- machine location print
- manufacturer's instructions for coupling, gear, and drive
- piping prints and details
- field wiring drawings
- starter installation and wiring details
- Carrier Standard Service Techniques manual, Chapter 15

Equipment Required

- mechanic's tools (refrigeration)
- volt-ohmmeter and clamp-on ammeter
- leak detector (halide or electronic)
- absolute pressure manometer or wet-bulb vacuum indicator
- portable vacuum pump (5 to 7.5 cfm [2.4 to 3.5 L/s]) or larger

INTRODUCTION

General — The 17FA refrigeration machine is designed for standard water chilling applications using HCFC-22 and is shipped from the factory as a completely assembled, tested, and charged package. Drive equipment (coupling, gear, turbine, or motor) may, in some instances, be installed at the factory or may be installed at the job site.

Normally, installation work consists of providing water and electrical services to the machine and drive, together with associated gages, thermometers, pumps, and controls.

Because of the number of possible machine and drive configurations, the individual job data (see list below) should be regarded as the primary source of information for installation procedures.

▲ WARNING

This unit uses a microprocessor control system.

Do not short or jumper between terminations on printed-circuit boards; control or board failure may result.

Be aware of electrostatic discharge (static electricity) when handling or making contact with the printed-circuit boards. Always touch a chassis (grounded) part to dissipate body electrostatic charge before working inside control center.

Use extreme care when handling tools near boards and when connecting or disconnecting terminal plugs. Circuit boards are delicate and can easily be damaged. Always hold boards by edges and avoid touching components and pin connections.

This equipment uses and can radiate radio frequency energy, and, if not installed and used in accordance with the instruction manual, may cause interference to radio communications. It has been tested and found to comply with the limits for a Class A computing device pursuant to Subpart J of Part 15 of FCC Rules, which are designed to provide reasonable protection against such interference when operated in a commercial environment. Operation of this equipment in a residential area is likely to cause interference, in which case the user, at his own expense, will be required to take whatever measures may be required to correct the interference.

Always store and transport replacement or defective boards in anti-static shipping bag.

RECEIVING MACHINE

Inspect Shipment (Fig. 1 and 2) — Do not open any valves or break any connections. The 17FA machine is shipped with the full refrigerant charge in the storage tanks and a holding charge in the other vessels.

1. Inspect for shipping damage while machine is still on the shipping conveyance. If machine appears damaged, or if it has been torn loose from its anchorage, have it examined by transportation inspectors before removal. Forward claim papers directly to the transportation company. Manufacturer is not responsible for any damage incurred in transit.
2. Check all items against shipping list. Notify your nearest Carrier representative if any item is missing.
3. To prevent damage or loss, leave all parts in their original containers until installation.

Identify Machine — Identify machine by machine model and serial number shown on nameplate. The machine identification plate and the storage tank nameplates are mounted on the machine support base at the end opposite the compressor drive.

The cooler and condenser nameplates are mounted on the vessel support feet at the end opposite the compressor drive.

The economizer nameplate is located on the economizer shell facing the compressor.

The compressor nameplate is mounted on the compressor support foot adjacent to the oil pump.

When corresponding with Carrier, always list the machine model number, serial number, and name of owner.

Model number nomenclature is as follows:

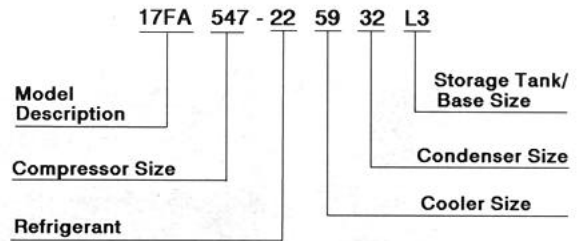

Provide Machine Protection — Protect machine, drive, and starting equipment from construction dirt and moisture. Do not remove protective shipping covers until ready for installation.

If machine may be exposed to freezing temperatures after water circuits have been installed, open all 4 waterbox drains (Fig. 2, Item 15) and drain all water from cooler and condenser. Leave drains open until system is to be refilled. Drain all water from compressor oil cooler (Fig. 3, Item 10) and from drive oil cooler, if supplied. Disconnect water supply line(s), remove drain plugs, and use compressed air to remove water from the oil cooler(s) and pumpout condenser.

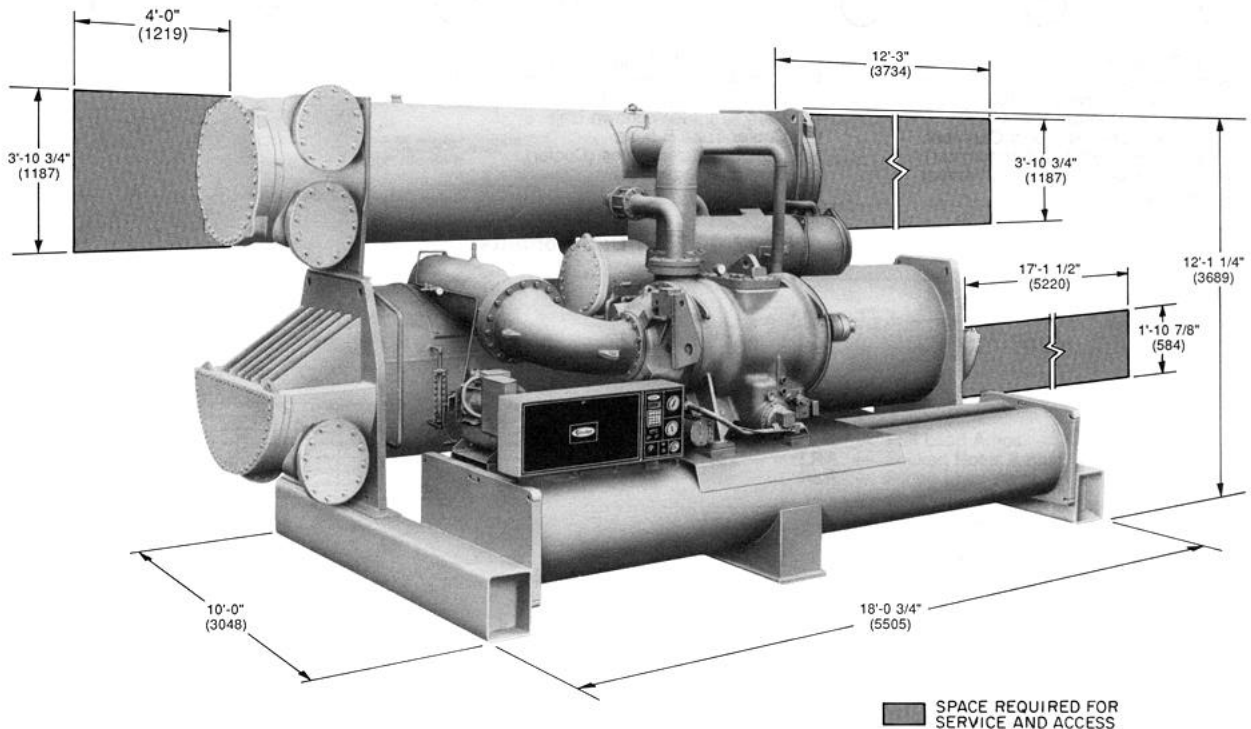

NOTES:

1. Overall length and width of machine is dependent on nozzle arrangement and drive type.
2. Dimensions in () are in millimeters.

Fig. 1 – 17FA Dimensions



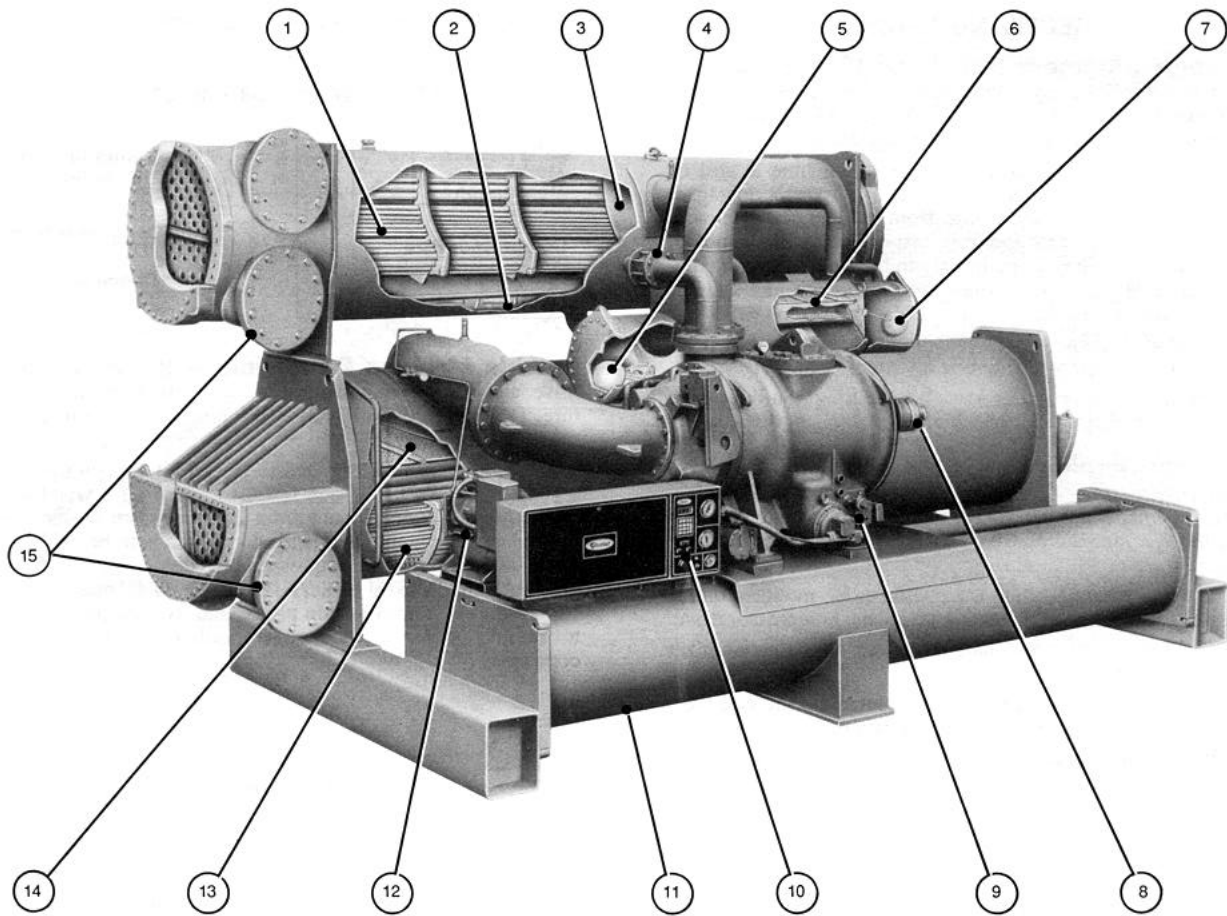

- | | |
|---------------------------------------|---|
| 1. Main Condenser Tube Bundle | 9. Lubrication Package (Pump) |
| 2. Subcooler Section of the Condenser | 10. 3200MP Microprocessor Control Panel |
| 3. Condenser Discharge Baffle | 11. Refrigerant Storage Vessels |
| 4. Economizer Damper Valve | 12. Refrigerant Pumpdown Unit |
| 5. Low Side Float Valve and Chamber | 13. Cooler Tube Bundle |
| 6. Flow Equalizer Plates (Economizer) | 14. Flow Equalizer Plates (Cooler) |
| 7. High Side Float Valve and Chamber | 15. Waterbox Drains (4) |
| 8. Drive Coupling | |

Fig. 2 – 17FA Components

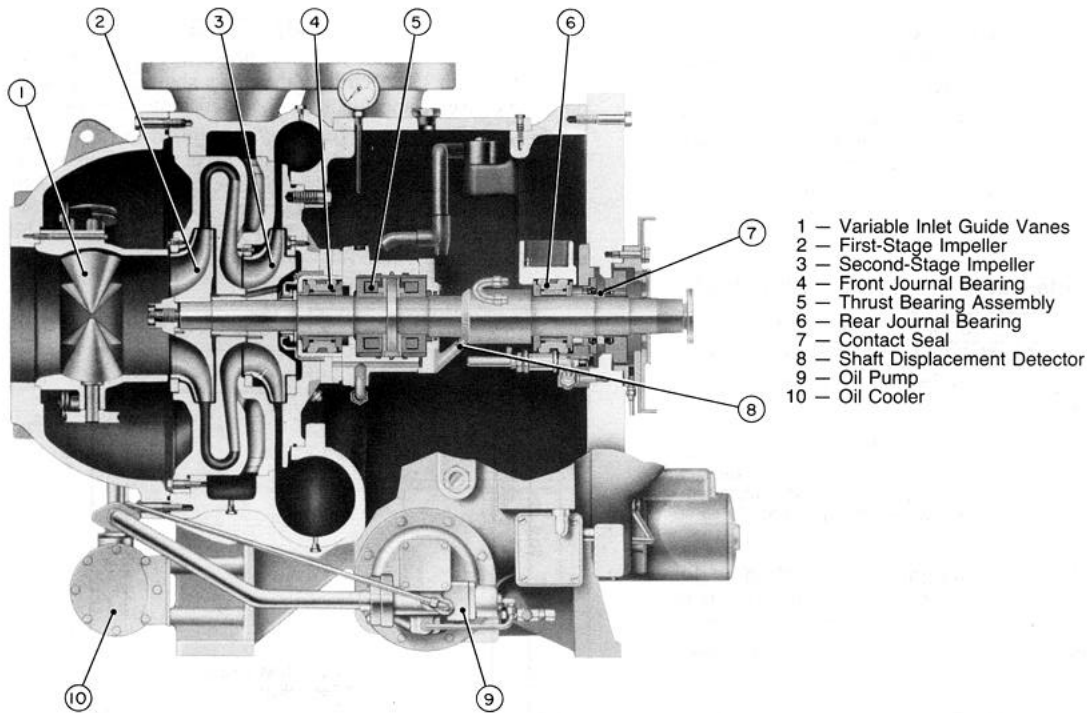

Fig. 3 – Compressor Components

RIGGING EQUIPMENT

Rig Machine Assembly — Series 17FA machines may be supplied with various drive components and drive support configurations. Therefore, rigging weights, dimensions, and points of lift, must be obtained from the job data.

⚠ WARNING

Lifting machine from points other than those specified may result in serious damage and personal injury. Rigging equipment and procedure must be adequate for machine weight. Refer to Table 1 for machine weights.

Use a spreader bar, if necessary, to avoid damage to machine components, piping, or insulation.

Take care to avoid stress on piping and connections on the underside of the machine. Damage may cause loss of entire refrigerant charge.

When machine is skidded, at least 4 rollers must be maintained under machine. *Do not drag.*

Rig Gear and Drive — Follow manufacturer's installation instructions for rigging this equipment.

Table 1 – Rigging Weights

MACHINE COMPONENT	WEIGHT	
	lb	kg
COOLER	28,700	13 018
CONDENSER	26,300	11 930
ECONOMIZER	1,600	726
STEEL BASE	12,500	5 670
COMPRESSOR	5,700	2 586
PUMPOUT	200	91
SUCTION ELBOW	500	227
MISCELLANEOUS PIPING	2,000	907
CONTROL PANEL	200	91
REFRIGERANT	5,500	2 495

NOTES:

- Weights are approximate.
- Machine is shipped as one piece. Individual rigging weights are shown here for reference purposes, in case field disassembly is required.
- Refrigerant is shipped either in machine or separately, as needed.
- The weight of the driver (motor and gear, turbine, etc.) is not included.

Record and Date Cooler Pressure Gage Reading (Fig. 2, Item 10) — Record both the pressure and the ambient temperature at the time of reading. This information is required for determining machine tightness during initial start-up.

INSULATION

Apply insulation only after machine has been proven leak-tight and dry by a Carrier service technician.

Table 2 indicates the degree of surface condensation that will occur for specific conditions of temperature and relative humidity. Carrier recommends that insulation be added to the cooler waterboxes (including the tube sheet) and suction elbow if the actual operating conditions would cause condensation.

Table 2 – Condensation vs Relative Humidity*

AMOUNT OF CONDENSATION	ROOM DRY-BULB TEMP		
	80 F (27 C)	90 F (32 C)	100 F (38 C)
	% Relative Humidity		
None	80	76	70
Slight	87	84	77
Extensive	94	91	84

*These approximate figures are based on 35 F (1.7 C) saturated suction temperature. A 2° F (1.1° C) change in saturated suction temperature changes the relative humidity values by 1% in the same direction.

Insulation of the cooler waterboxes should allow for service access and removal of covers. Do not cover nameplates.

The recommended insulation is 3/4-in. (19-mm) thick closed-cell neoprene with a thermal conductivity K value of 0.28 $\frac{\text{Btu} \cdot \text{in.}}{\text{hr} \cdot \text{ft}^2 \cdot ^\circ \text{F}}$ (0.0404 $\frac{\text{W}}{\text{m} \cdot ^\circ \text{C}}$). Insulation should

conform with UL (Underwriters' Laboratories) Standard 94 and have classification 94 HBF. See Table 3.

Table 3 – Insulation Requirements

LOCATION	ft ²	m ²
Cooler	345	32.1
Economizer	45	4.2

NOTES:

- Cooler value includes marine waterbox on one end (even-pass arrangement).
- Values are approximate.

Depending on job conditions, other machine components also may be insulated. Check your job data for specific insulation requirements.

⚠ CAUTION

Factory-supplied insulation is not flammable, but can be damaged by welding sparks and open flame. Protect insulation with a wet canvas cover.

17FA MOUNTING

The machine contact surfaces shown in Fig. 4 are those associated with 17FA chillers that have short coolers, standard condensers, and machine-mounted motor drives.

The 17FA machine, however, is supplied in many configurations that require different contact surfaces. These configurations include long coolers, 17DA type condensers, and a variety of motor or turbine drives. For this reason, the requirements for 17FA mounting and isolation should be obtained from the individual job data.

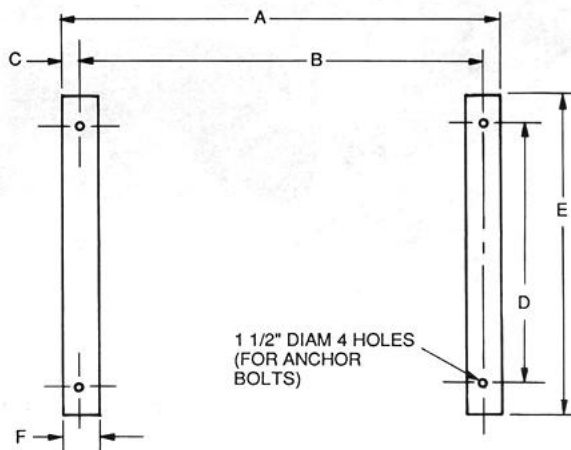

DIMENSIONS (ft-in)

COOLER SIZE	BASE SIZE	A	B	C	D	E	F
10-19 40-49	S	12-11	12-3	0-4	6-6	8-6	0-8
20-29 50-59	L	13-2 ³ / ₄	12-2 ³ / ₄	0-6	8-0	10-0	1-0

DIMENSIONS (mm)

COOLER SIZE	BASE SIZE	A	B	C	D	E	F
10-19 40-49	S	400	370	10	200	260	20
20-29 50-59	L	404	370	15	244	305	31

NOTE:

- S – Short Cooler
- L – Long Cooler

Fig. 4 – 17FA Standard Contact Surfaces



To ensure that proper drive alignment is established and maintained, each 17FA unit should receive the same care in mounting as any open-drive machine, including the following:

1. The floor must be level and rigid.
2. The drive train must be level, end-to-end, within 1/32 in. (8 mm).
3. The machine must be firmly anchored to prevent "walking." This is particularly important with turbine drives because of the effect of steam piping. (See Fig. 5.)

Isolation — Normally the 17FA machine is anchored to the floor without any isolation. However, all 17FA units are supplied with 7 elastomeric pads of resilient cross-ribbed neoprene, since floor preparation techniques vary. Consult your job data for specific details. Methods for adjusting spring mounts can be found in the Carrier Standard Service Techniques manual, Chapter 15.

At the time of installation, the full refrigerant charge is contained in the 17FA integral storage tanks. This refrigerant is redistributed throughout the machine at initial start-up.

▲ CAUTION

To avoid damage to machine and piping, spring isolators must remain blocked until refrigerant is redistributed and machine is started.

Install Couplings, Gear, and Drive — Refer to manufacturer's instructions for coupling assembly, lubrication, and alignment tolerances. Be sure that gear and drive installation and alignment are in accordance with manufacturer's instructions.

General procedures for mounting couplings and for aligning gear and drive are detailed in Carrier Standard Service Techniques manual, Chapter 15. Refer to job data for specific requirements in these areas.

In those instances where gear and drive have been pre-assembled at Carrier, alignment should be carefully checked to be sure that it has not been affected by shipment or by rigging the machine.

Final Alignment — Compressor and drive alignment should be rechecked after all piping, including water and steam, has been completed. Procedures and tolerance requirements are given in Carrier Standard Service Techniques manual, Chapter 15. *Compressor and drive components must not be doweled until machine has been operated and hot checked.*

Grout — Refer to job data for grouting requirements and procedures. Additional grouting information can be found in the Standard Service Techniques manual, Chapter 15.

FIELD PIPING

Water to Oil Cooler — Water supply may be either city water or chilled water.

▲ CAUTION

City water must be clean and noncorrosive. Water side erosion or corrosion of the oil cooler coil may lead to extensive machine damage not covered by the standard warranty.

Pipe city water to an open sight drain (Fig. 6).

If water from the machine chilled water circuit is used for oil cooling, it should enter the oil cooler from the en-

tering water line of the machine cooler (Fig. 7). Water leaving the oil cooler should connect to the leaving water line of the machine cooler at a point downstream from the chilled water sensor, so that oil cooler leaving water temperature does not affect the sensor readings.

Locate the oil cooler leaving water connection at some distance from any water temperature indicators. On single-pass machines, water leaving the oil cooler should be connected into the suction side of the chilled water pump so that adequate pressure drop is assured for oil cooling.

The nominal conditions for oil cooler water flow are:

Flow rate	30 gpm (1.9 L/s)
Leaving temperature	85 to 100 F (29 to 38 C)
Pressure drop at oil cooler	7.25 psid (50 kPad)
Max differential pressure across closed solenoid valve	150 psid (1034 kPad)

The oil cooler connections are 1-1/4 in. FPT on a 17FA5 size compressor.

Water to Heat Exchangers — Install piping per job data piping prints and details, and as outlined below.

▲ CAUTION

Water must be within design flow limits, clean, and treated to ensure proper machine performance and reduce the potential of tubing damage due to corrosion, scaling, or erosion. Carrier assumes no responsibility for chiller damage resulting from untreated or improperly treated water.

▲ CAUTION

Machine insulation can be damaged by welding sparks or open flame. Protect insulation with wet canvas cover or asbestos.

IMPORTANT: Chilled water control element (Fig. 8) can be severely damaged by weld heat.

1. Remove control element before welding water nozzle. Carefully replace control element after welding.
2. Offset the pipe connections to permit the removal of waterbox covers for maintenance, and provide clearance for tube cleaning.
3. Provide openings in water piping for required gages and thermometers (Fig. 8). To ensure accurate readings, thermometer wells in leaving water pipe should be 6 to 10 pipe diameters from waterbox and should extend inside the pipe a minimum of 2 in. (51 mm). This allows thorough mixing and temperature stabilization before water reaches thermometer.
4. Install air vents at all high points in piping to remove air and prevent water hammer.
5. Water flow direction must be as specified on job flow diagrams.
6. Water flow switches must be of vaportight construction. Locate switches at top of pipe, in a horizontal run and at least 5 pipe diameters from any bend.
7. Install waterbox vent and drain piping as specified in the job data.
8. Install pipe hangers where needed. Do not place any weight or stress on waterbox nozzles or flanges.



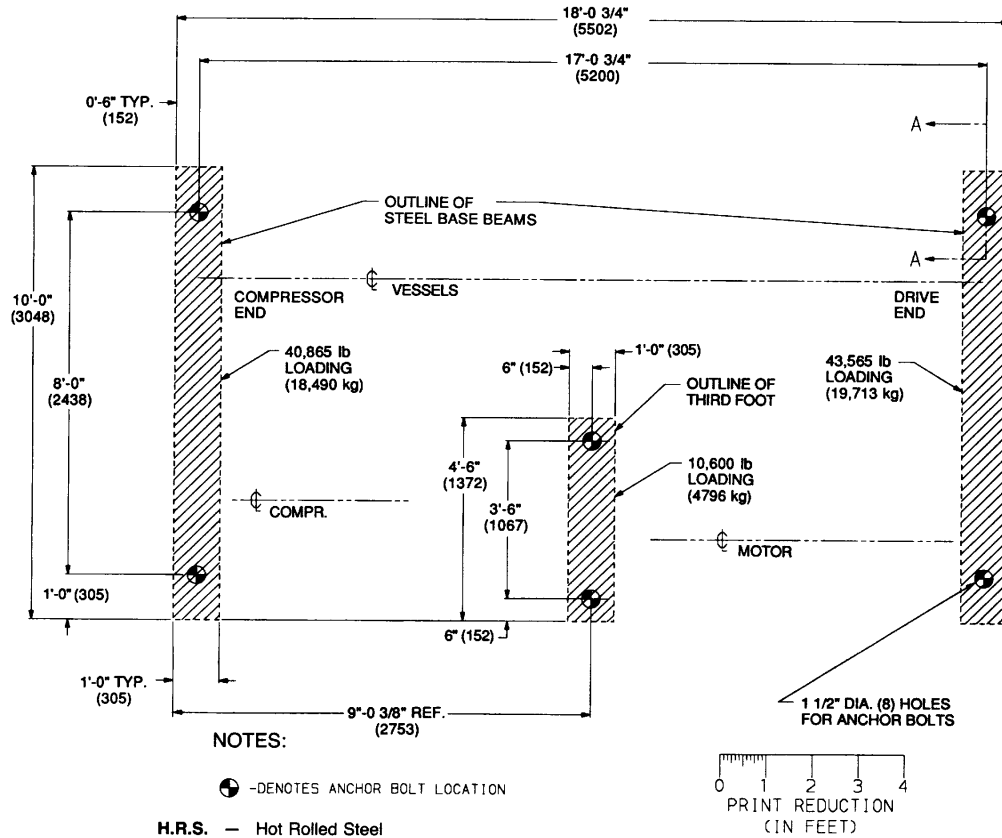
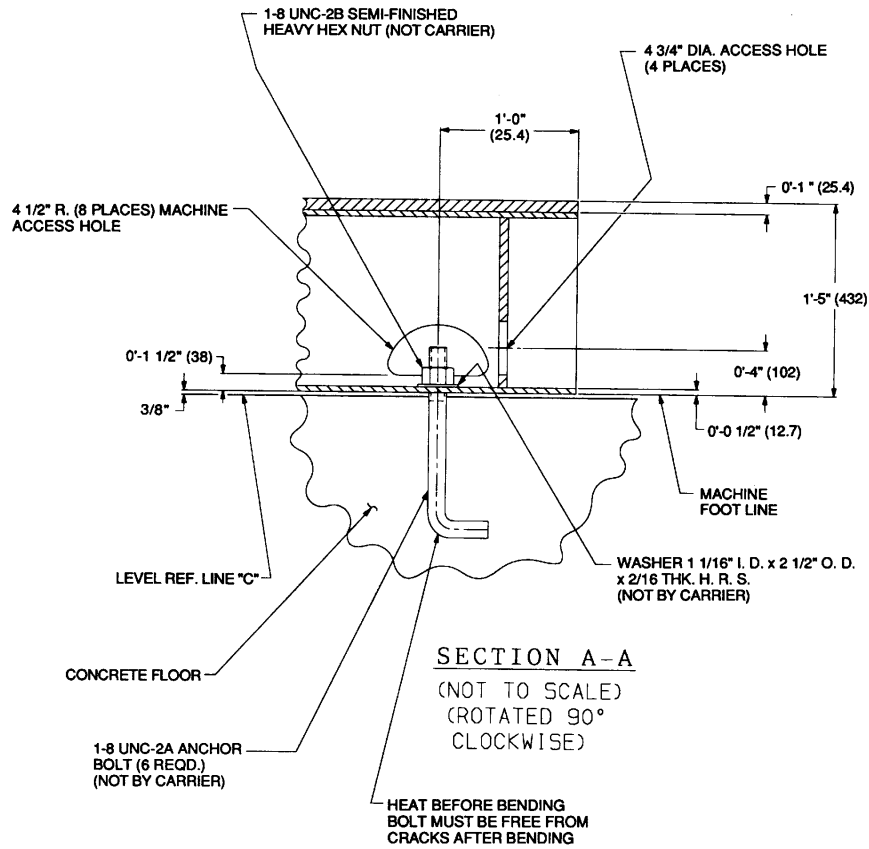

Fig. 5 — 17FA Contact Surfaces



Water to Pumpout Condenser — Obtain water from source (usually city water) specified in job data. Attach water supply and return lines to 1/2-in. FPT connections at the end of the condenser. Shutoff valves or other controls are customer supplied. Water must be clean and noncorrosive. Pipe the leaving water line to an open sight drain, and provide for water drainage during extended shutdown.

Relief Devices — Series 17FA chillers are furnished with relief valves for the cooler, storage tank (set at 185 psig [1276 kPa] and sized in accordance with the latest ASHRAE 15 requirements), and a rupture disc for the pump-down condenser. The device quantity and the outlet connection sizes are listed in Table 4.

Table 4 — Relief Valve Data

LOCATION	OUTLET SIZE	
	1-in. FPT	3/8-in. Male Flare
	No. of Valves	
Cooler	3	—
Storage Tank	2	—
Pumpdown Unit Condenser	—	1

⚠ DANGER

Refrigerant discharged into closed spaces can displace oxygen and cause asphyxiation.

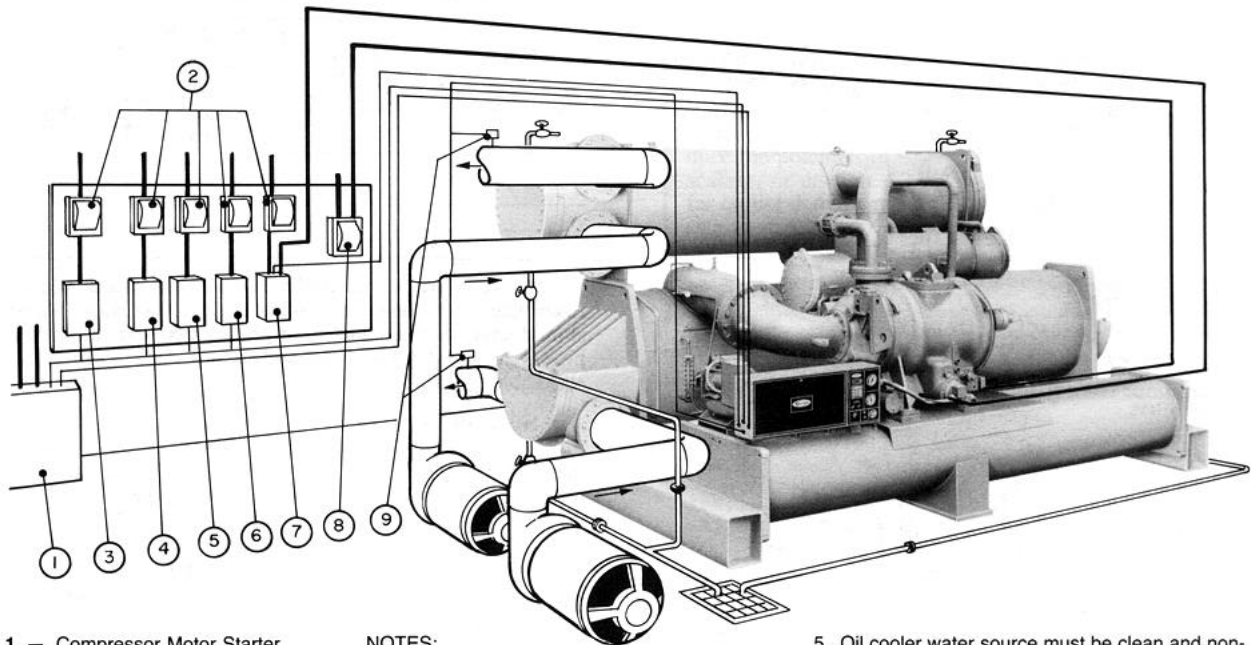

- 1 — Compressor Motor Starter
- 2 — Fused Disconnects
- 3 — Cooling Tower Fan Starter
- 4 — Condenser Water Pump Starter
- 5 — Cooler Water Pump Starter
- 6 — Gear Auxiliary Oil Pump Starter
- 7 — Lube Oil Pump Starter
- 8 — Fused Disconnect for Oil Heater and Heater Controller (115 v)
- 9 — Water Flow Switches

NOTES:

1. Separate 115-volt source for controls, unless transformer is furnished with compressor controller.
2. Wiring and piping shown does not include all details for a specific installation. Refer to certified electrical drawings.
3. Wiring must conform to applicable local and national codes.
4. Pipe per standard techniques. See Carrier System Design manual for details.

5. Oil cooler water source must be clean and non-corrosive. City water or chilled water may be used. Recommended flow conditions are 30 gpm (1.9 L/s) water at 85 F (29 C) maximum entering temperature.
6. Oil heater and seal oil pump must be on separate circuits providing continuous service.
7. Control wiring from gear auxiliary oil pump to starter not shown.

Fig. 6 — 17FA Piping and Wiring (Typical)



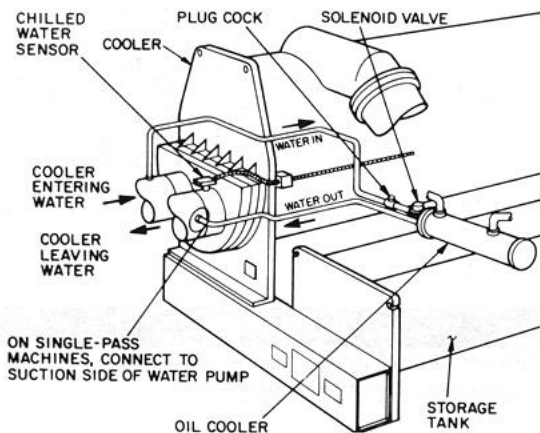
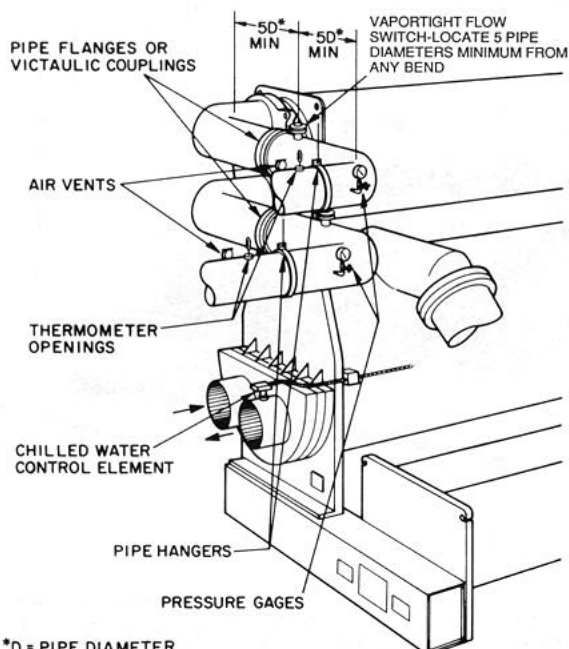

Fig. 7 – Water Piping, Oil Cooler to Chilled Water Circuit (Typical)



*D = PIPE DIAMETER

Fig. 8 – Typical Nozzle Piping

Outlet from relief devices should be vented to the outdoors in accordance with latest ANSI (American National Standards Institute) safety codes for mechanical refrigeration. See Table 5A for the maximum allowable equivalent length of discharge pipe from relief device to atmosphere. Do not use pipe sizes smaller than the exit fitting of the relief device.

Table 5A assumes that the cooler relief valves are manifolded into a common discharge line.

Table 5A – Maximum Allowable Equivalent Length of Discharge Pipe

LOCATION	ENGLISH (ft)						
	SCHEDULE 40 PIPE SIZE (in.)						
	1/2	3/4	1	1 1/2	2	3	4
Cooler	—	—	—	—	23	167	649
Storage Tanks ("L" Base)	—	—	—	122	420	3080	—
Pumpdown Unit Condenser	16	65	219	1867	—	—	—

LOCATION	SI (m)						
	SCHEDULE 40 PIPE SIZE (in.)						
	1/2	3/4	1	1 1/2	2	3	4
Cooler	—	—	—	—	7	51	198
Storage Tanks ("L" Base)	—	—	—	37	128	939	—
Pumpdown Unit Condenser	5	20	67	570	—	—	—

Table 5B – Discharge Pipe Internal Area

17FA	ENGLISH	SI
SCHEDULE 40 PIPE SIZE	Sq. in.	(cm ²)
1/2	.305	(.77)
3/4	.533	(1.35)
1	.863	(2.2)
1 1/2	2.038	(5.2)
2	3.356	(8.5)
3	7.39	(18.8)
4	12.73	(32.3)

If the relief valves of cooler and storage tank are to be manifolded into a common discharge pipe, the manifold pipe should have an area equal to or greater than the sum of the pipe areas selected for cooler and storage tank individually, see Table 5B.

Air Supply — Machines with pneumatic capacity control require clean, dry air at 25 psi (172 kPa) for the pneumatic thermostat (Fig. 9) and the electro-pneumatic (EP) relay (Fig. 10), and 35 to 90 psi (241 to 621 kPa) supply air for the guide vane actuator (Fig. 11). Provide 200 standard cubic inches per minute (scim) [.008 m³/sec] total air volume for the thermostat, relay, and actuator.

Air may also be required for optional controls such as a hot gas bypass; check job data.

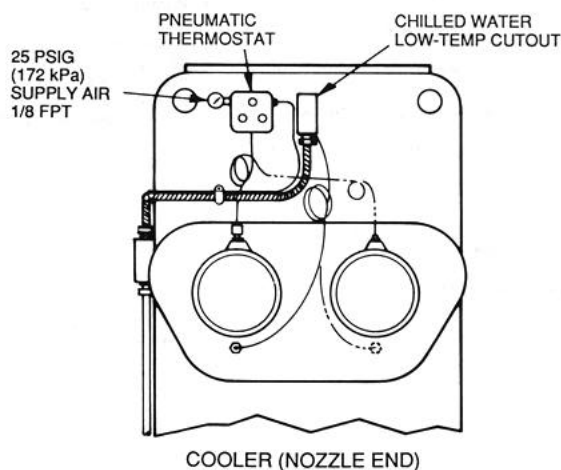

Fig. 9 – Field Connection to Pneumatic Thermostat

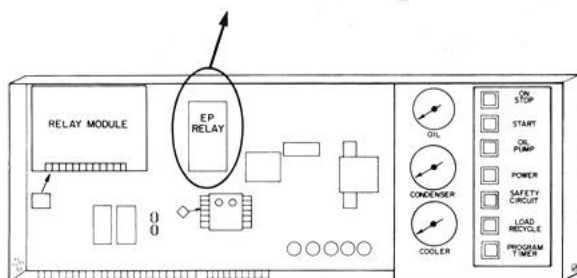
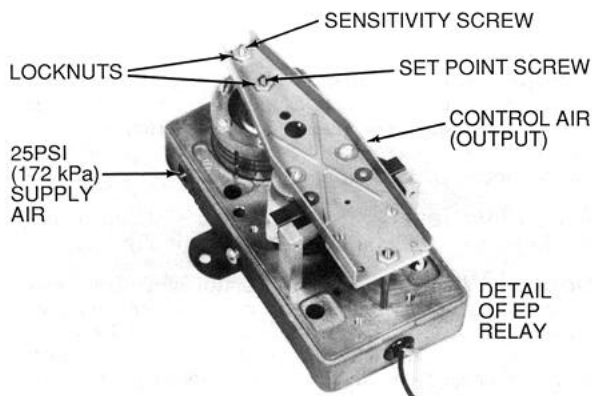

Fig. 10 – Supply Air Connection for EP Relay

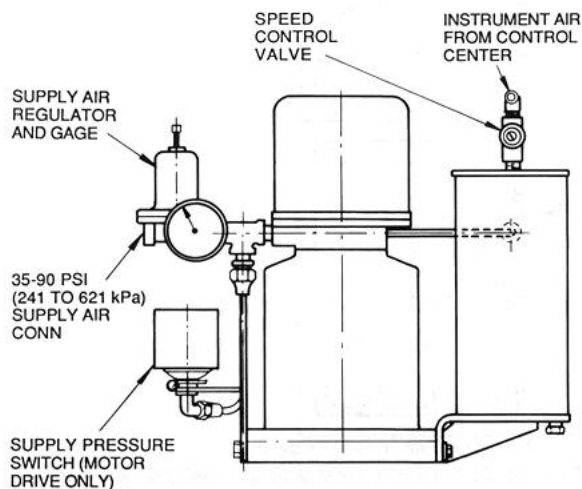

Fig. 11 – Air Supply Connection to Pneumatic Guide Vane Actuator

Piping to Turbine — Water and steam connections to the turbine should be made only after alignment between all machine and drive components has been verified as being within .002 in. (.051 mm) in parallel and .00033 in. (.0084 mm) per inch of traverse across the coupling face in angular alignment.

Steam piping must be designed and supported so that pipe forces and movements at the turbine flanges are essentially zero.

Follow the turbine manufacturer's recommendations and all applicable codes when installing steam piping.

Vent and Drain Connections — All vent and drain connections are found in the waterbox shell. Vent and drain connection size is 3/4-in. NPT.

Provide high points of the machine piping system with vents and the low points with drains. If shutoff valves are provided in the main water pipes near the unit, a minimum amount of system water is lost when the heat exchangers are drained. This reduces the time required for drainage and saves on the cost of re-treating the system water.

It is recommended that pressure gages be provided at points of entering and leaving water to measure pressure drop through the heat exchanger. Gages may be installed as shown in Table 6. Pressure gages installed at the vent and drain connections do not include nozzle pressure losses.

Use a reliable manometer to measure pressure differential when determining water flow. Regular gages are insensitive and do not provide accurate measurement of flow conditions.

Table 6 – Pressure Gage Location

NUMBER OF PASSES	GAGE LOCATION (Cooler or Condenser)
1 and 3	One gage in each waterbox
2 and 4	Two gages in waterbox with nozzles

Auxiliary Connections — Depending on your installation, connections may be made at the locations listed in Table 7.

Table 7 – Auxiliary Connections Table

SIZE AND STYLE	USAGE
1-in. FPT	Oil Cooler Water Inlet Connection
1-in. FPT	Oil Cooler Water Outlet Connection
1/4-in. NPT	Guide Vane Actuator Supply Air Connection (90 psig [621 KPa], max.)
1/2-in. NPT Conduit Connector	Oil Pump Motor Electrical Connection
1-in. FPT	Cooler Relief Valve Refrigerant Vapor Vent Connection
1-in. FPT	Storage Tank Relief Valve Refrigerant Vapor Vent Connection
1/2-in. FPT	Pumpout Water Inlet Connection
1/2-in. FPT	Pumpout Water Outlet Connection
3/8-in. Male Flare	Pumpout Condenser Refrigerant Vapor Vent Connection (Rupture Disc)
3/4-in. NPT	Waterbox Vent and Drain Connection

FIELD WIRING

General — Wiring must be in accordance with all applicable electrical codes and with wiring drawings furnished by Carrier and by the starter manufacturer.

Wiring schematics and electrical controls shown in this book are typical (Fig. 12-16), but may differ from your particular job arrangement; check your job data.

⚠ WARNING

Do not check high-voltage supply (over 600 v) without proper equipment and precautions. Serious personal injury can result. Follow power company recommendations.

Oil Heater and Thermostat — Use power from separate source with fused disconnect to ensure that proper oil temperature is maintained at machine shutdown. Wiring schematic is shown in Fig. 12.

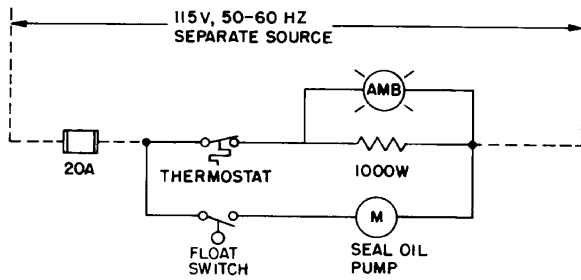

--- Field Wiring
 AMB - AMBER

Fig. 12 - Oil Heater and Seal Oil Pump Wiring Schematic (Typical)

Compressor Oil Pump - Use separate starter, overloads, and fused disconnect as shown on job wiring diagrams. Check oil pump nameplate near terminal box for pump voltage requirements. See Fig. 3 for oil pump terminal box location.

Automatic Seal Oil Return Pump - Connect pump to 115-v source with oil heater as shown in Fig. 12.

Control Wiring - Connect control wires from main motor starter or drive circuit, oil pump starter, and water pump starters to terminals within machine control center as shown on job wiring drawings. Figure 13 shows the numbering sequence for field wiring connections within the control center.

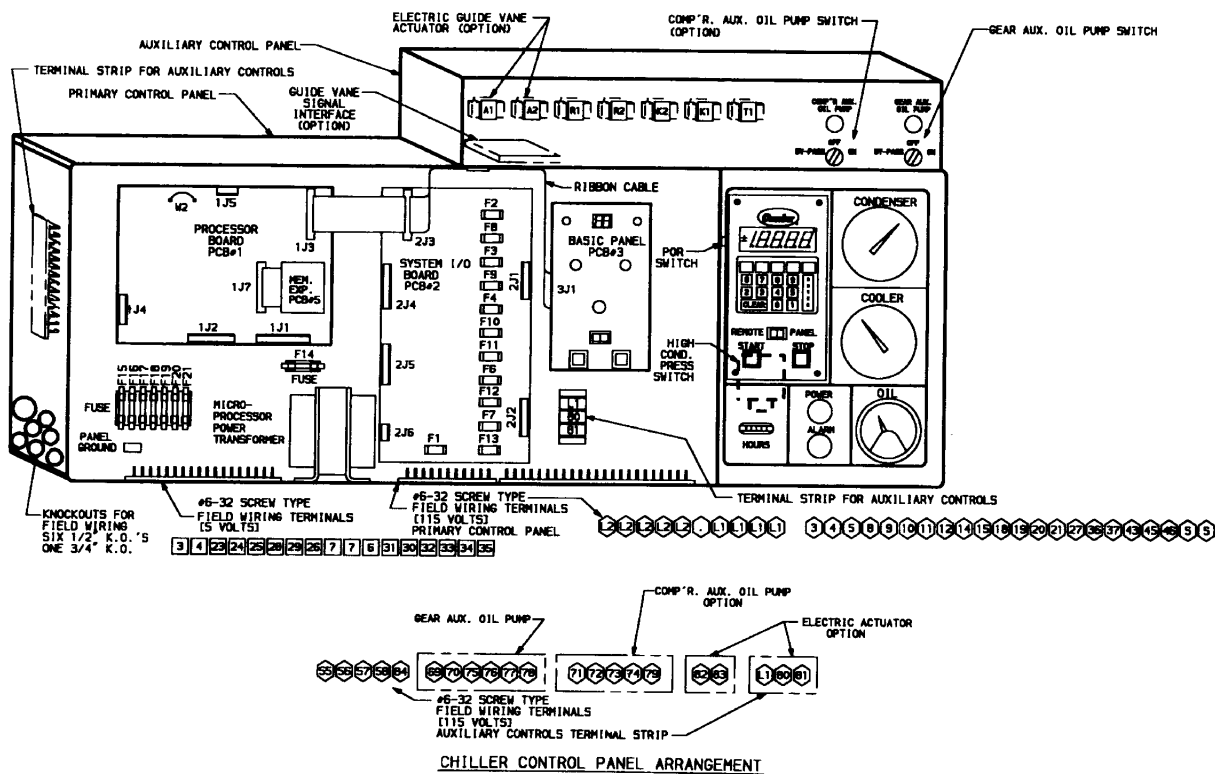

Fig. 13 - 17FA Field Wiring Terminal Strip



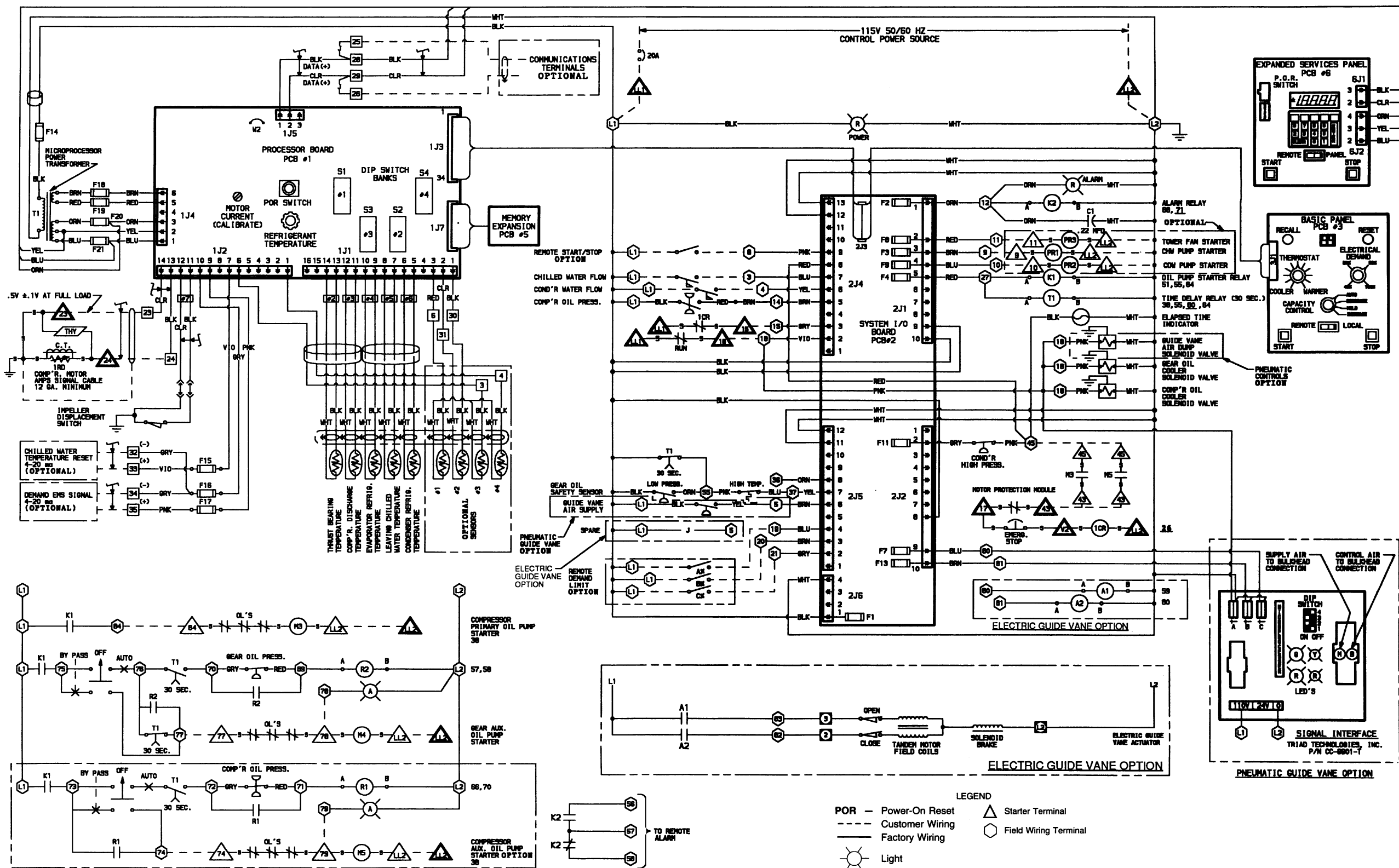
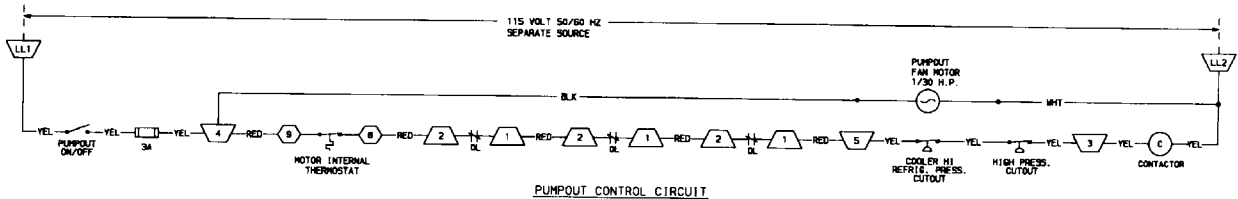
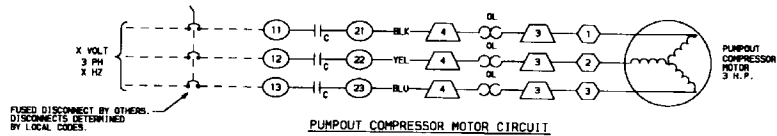
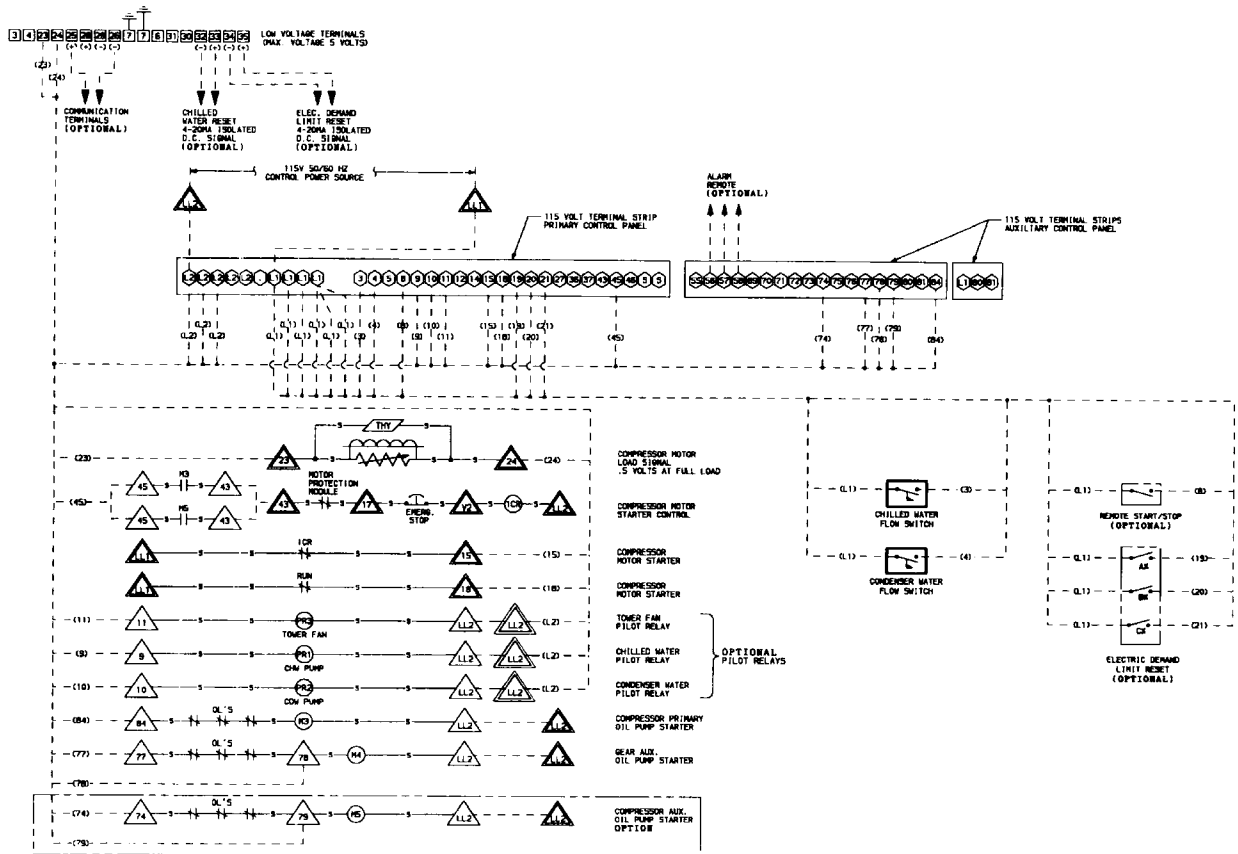

Fig. 14 - Control Wiring (Typical)



PUMPOUT COMPRESSOR MOTOR				
VOLTS	PHASE	HERTZ	FLA	LRA
208	3	60	12.2	
230	3	60	11.5	
400 - 480	3	50/60	5.8	
220	3	50	9.8	26.6
575	3	50	4.6	

- LEGEND**
- FLA** — Full Load Amps
 - LRA** — Locked Rotor Amps
 - RLA** — Rated Load Amps
 - Customer Wiring
 - Factory Wiring
 - ▲ Compressor Motor Starter Terminal
 - Contactor Terminal
 - ▱ Overload Terminal
 - ▱ Pumpout Terminal
 - ▱ Pumpout Comp'r. Terminal
 - ▲ Starter Terminal

NOTE:
X — volt/hz per job requirement

Fig. 15 — Field Wiring (Typical)



COMPRESSOR OIL PUMP CIRCUIT

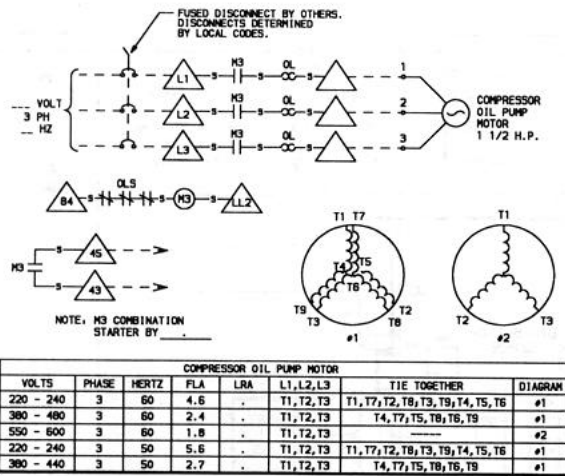

GEAR AUXILIARY OIL PUMP CIRCUIT

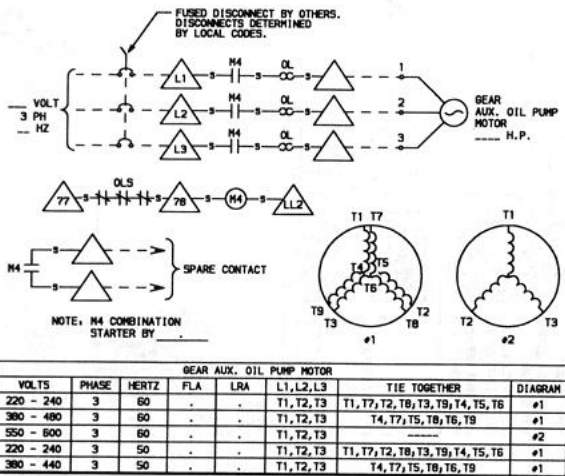

Fig. 15 – Field Wiring (Typical) Cont'd

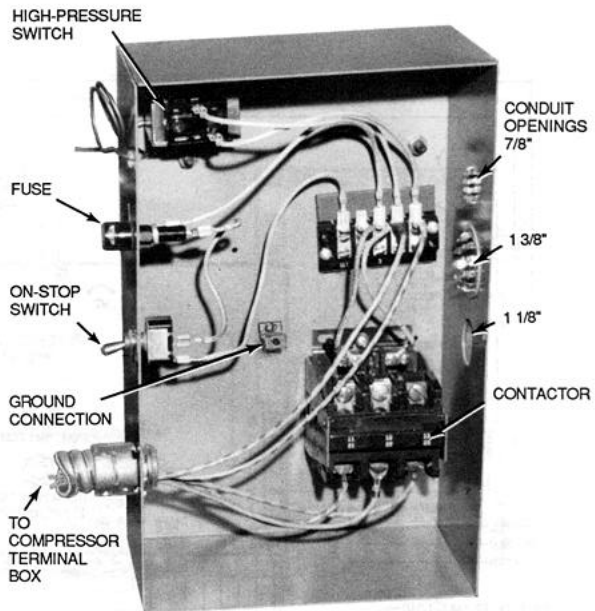

Fig. 16 – Pumpout Unit Controls

Pumpout Unit — Connect power wires to contactor in pumpout control box as shown on job wiring drawings. Check pumpout compressor nameplate for proper voltage. Fig. 16 illustrates typical pumpout controls and wiring. Use separate disconnect.

Water Flow Switches — Wire flow switches or other interlocks into machine safety circuits as shown on job wiring drawings.



Copyright 1992 Carrier Corporation

Manufacturer reserves the right to discontinue, or change at any time, specifications or designs without notice and without incurring obligations.

Book	2	PC 211	Catalog No. 531-712	Printed in U.S.A.	Form 17FA-4SI	Pg 17	8-92	Replaces: New
Tab	5d							

