



## Hermetic Centrifugal Liquid Chillers

### SAFETY CONSIDERATIONS

**Centrifugal liquid chillers are designed to provide safe and reliable service when operated within design specifications. When operating this equipment, use good judgment and safety precautions to avoid damage to equipment and property or injury to personnel.**

**Be sure you understand and follow the procedures and safety precautions contained in the machine instructions as well as those listed in this guide.**

#### **▲ DANGER**

DO NOT VENT refrigerant relief valves within a building. Outlet from rupture disc or relief valve must be vented outdoors in accordance with the latest edition of ANSI/ASHRAE 15 (Safety Code for Mechanical Refrigeration). The accumulation of refrigerant in an enclosed space can displace oxygen and cause asphyxiation.

PROVIDE adequate ventilation in accordance with ANSI/ASHRAE 15, especially for enclosed and low overhead spaces. Inhalation of high concentrations of vapor is harmful and may cause heart irregularities, unconsciousness, or death. Intentional misuse can be fatal. Vapor is heavier than air and reduces the amount of oxygen available for breathing. Product causes eye and skin irritation. Decomposition products are hazardous.

DO NOT USE OXYGEN to purge lines or to pressurize a machine for any purpose. Oxygen gas reacts violently with oil, grease and other common substances.

NEVER EXCEED specified test pressures. VERIFY the allowable test pressure by checking the instruction literature and the design pressures on the equipment nameplate.

DO NOT VALVE OFF any safety device.

BE SURE that all pressure relief devices are properly installed and functioning before operating any machine.

#### **▲ WARNING**

DO NOT WELD OR FLAME CUT any refrigerant line or vessel until all refrigerant (*liquid and vapor*) has been removed from chiller. Traces of vapor should be displaced with dry air or nitrogen and the work area should be well ventilated. *Refrigerant in contact with an open flame produces toxic gases.*

DO NOT USE eyebolts or eyebolt holes to rig machine sections or the entire assembly.

DO NOT work on high-voltage equipment unless you are a qualified electrician.

DO NOT WORK ON electrical components, including control panels, switches, starters or oil heater until you are sure ALL POWER IS OFF and no residual voltage can leak from capacitors or solid-state components.

LOCK OPEN AND TAG electrical circuits during servicing. IF WORK IS INTERRUPTED, confirm that all circuits are de-energized before resuming work.

DO NOT syphon refrigerant by mouth.

AVOID SPILLING liquid refrigerant on skin or getting it into the eyes. USE SAFETY GOGGLES. Wash any spills from the skin with soap and water. If any enters the eyes, IMMEDIATELY FLUSH EYES with water and consult a physician.

NEVER APPLY an open flame or live steam to a refrigerant cylinder. Dangerous overpressure can result. When necessary to heat refrigerant, use only warm (110 F/43 C) water.

DO NOT REUSE disposable (nonreturnable) cylinders nor attempt to refill them. It is DANGEROUS AND ILLEGAL. When cylinder is emptied, evacuate remaining gas pressure, loosen the collar and unscrew and discard the valve stem. DO NOT INCINERATE.

CHECK THE REFRIGERANT TYPE before charging machine. High-pressure refrigerant in a low-pressure machine can cause vessels to rupture if the relief devices cannot handle the refrigerant volume.

Operation of this equipment with refrigerants other than those cited herein should comply with ANSI/ASHRAE-15 (latest edition). Contact Carrier for further information on use of this machine with other low-pressure refrigerants.

DO NOT ATTEMPT TO REMOVE fittings, covers, etc. while machine is under pressure or while machine is running. Be sure pressure is at zero psig before breaking any refrigerant connection.

CAREFULLY INSPECT all relief valves, rupture discs and other relief devices AT LEAST ONCE A YEAR. If machine operates in a corrosive atmosphere, inspect the devices at more frequent intervals.

DO NOT ATTEMPT TO REPAIR OR RECONDITION any relief valve when corrosion or build-up of foreign material (rust, dirt, scale, etc.) is found within the valve body or mechanism. Replace the valve.

DO NOT install relief devices in series or backwards.

USE CARE when working near or in line with a compressed spring. Sudden release of the spring can cause it and objects in its path to act as projectiles.

#### **▲ CAUTION**

DO NOT STEP on refrigerant lines. Broken lines can whip about and cause personal injury.

DO NOT climb over a machine. Use platform, catwalk or staging. Follow safe practices when using ladders.

USE MECHANICAL EQUIPMENT (crane, hoist, etc.) to lift or move inspection covers or other heavy components. Even if components are light, use such equipment when there is a risk of slipping or losing your balance.

BE AWARE that certain automatic start arrangements CAN ENGAGE THE STARTER. Open the disconnect *ahead of* the starter in addition to shutting off the machine or pump.

USE only repair or replacement parts that meet the code requirements of the original equipment.

DO NOT VENT OR DRAIN water boxes containing industrial brines, liquid, gases or semisolids without permission of your Process Control Group.

DO NOT LOOSEN water box cover bolts until the water box has been completely drained.

DOUBLE-CHECK that coupling nut wrenches, dial indicators or other items have been removed before rotating any shafts.

DO NOT LOOSEN a packing gland nut before checking that the nut has a positive thread engagement.

PERIODICALLY INSPECT all valves, fittings and piping for corrosion, rust, leaks or damage.

PROVIDE A DRAIN connection in the vent line near each pressure relief device to prevent a build-up of condensate or rain water.

UNISHELL SIZE	DIMENSION X	
	(in.)	(mm)
50-65	1½	38
71-78	2	51

TO REAR LIFTING LUG

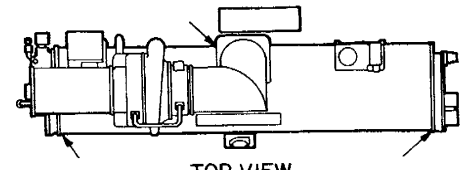

TOP VIEW  
ARROWS INDICATE 3 LIFTING POINTS

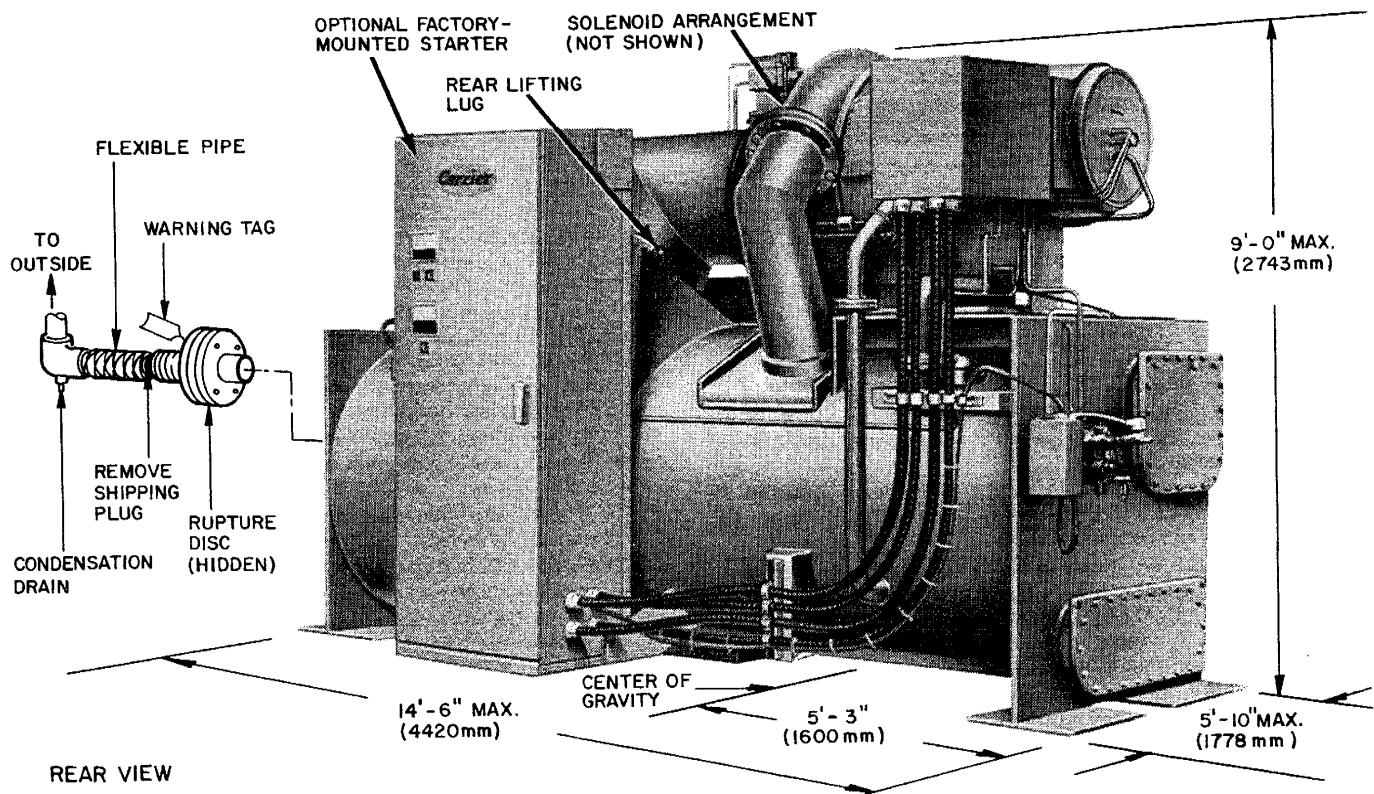
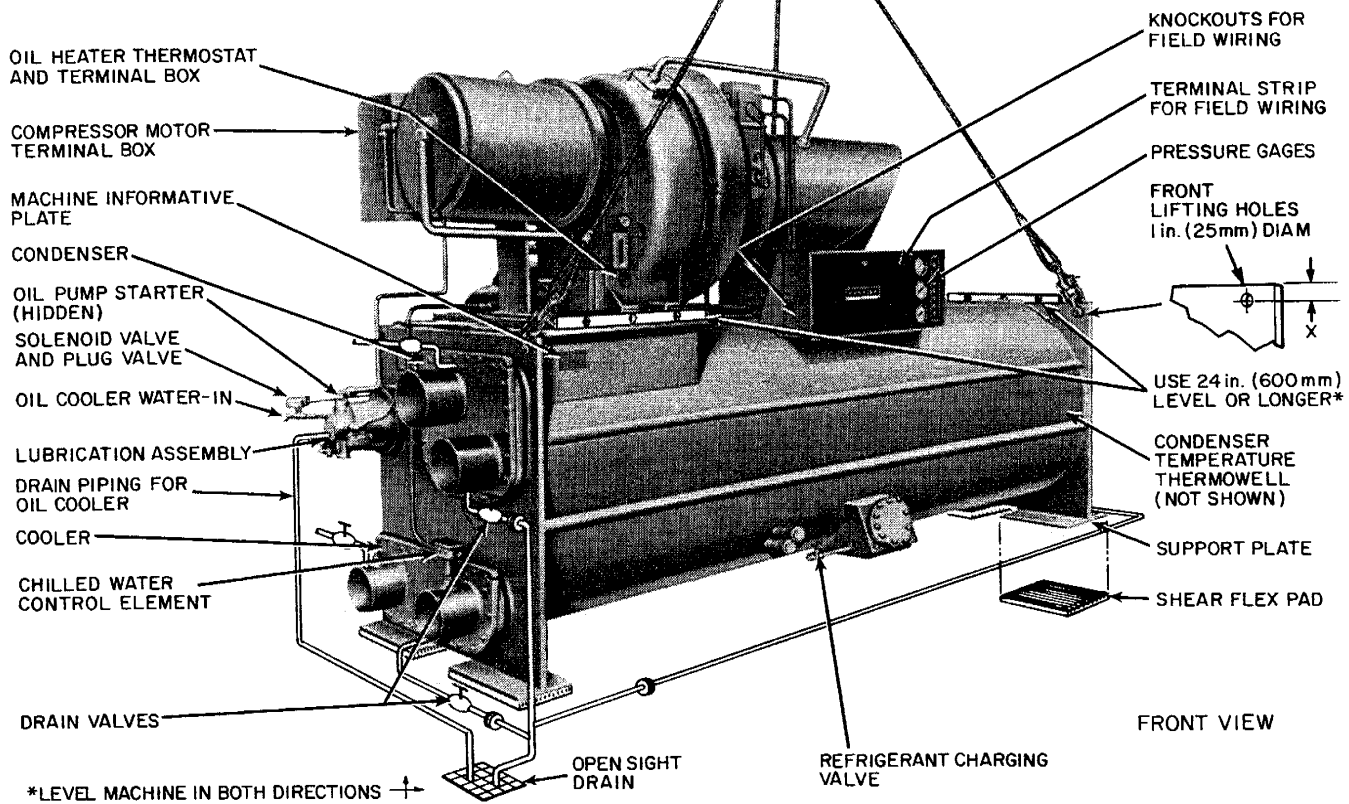

Fig. 1 — Typical Installation (200 thru 500 tons/700 thru 1750 kW)

## INTRODUCTION

**GENERAL** — The 19DM machine is factory assembled, wired, and tested. Installation (not by Carrier) consists primarily of establishing water and electrical services to the machine. Rigging, installation, field wiring, and field piping are the responsibility of the contractor and/or customer. Carrier has no installation responsibilities for the equipment. The scope of Carrier's duties at time of start-up are listed in Introduction of the 19DM Start-Up, Operation, and Maintenance Instructions.

**JOB DATA** — Necessary information consists of: machine location drawings, piping drawings, field wiring diagrams, rigging guide and starter installation details (if starter is not factory mounted).

## INSTALLATION

### STEP 1 — CHECK EQUIPMENT AND PREPARE FOR INSTALLATION

#### Identify Machine

The machine model number, serial number, and unishell size are stamped on machine informative plate. See Fig. 1 for location. Check this information against shipping papers and job data.

#### Inspect Shipment

*Do not open valves or break any connections. The 19DM machine is shipped under vacuum.*

Inspect for shipping damage while machine is still on shipping conveyance. If machine appears damaged or has been torn loose from its anchorage, have it examined by transportation inspectors before removal. Forward claim papers directly to transportation company. *Manufacturer is not responsible for any damage incurred in transit.*

Check all items against shipping list. Notify nearest office of Carrier Air Conditioning immediately if any item is missing.

To prevent loss or damage, leave all parts in original packages until installation.

#### Rig Machine Properly

Refer to rigging instructions in plastic envelope attached to machine. Lift machine only from 3 points indicated on rigging guide and Fig. 1 (all views) at left.

**WARNING:** Lifting machine from points other than those specified may result in serious damage and personal injury.

Rigging equipment and procedure must be adequate for machine weight (Table 1).

#### Provide Machine Protection

Protect machine and starter from construction dirt and moisture. Keep protective shipping covers in place until machine is ready for installation.

If machine will be exposed to freezing temperatures after water circuits have been installed, open water box drains and remove all water from cooler and condenser. Leave drains open until system is to be filled. Drain all water from the oil cooler (Fig. 1). If oil cooler water supply line has been installed, disconnect it and use compressed air to remove any water.

#### Record and Date Oil Reservoir Pressure Gage Reading (Fig. 1)

Keep a record of both pressure and ambient temperature at the time of reading. This information is required for checking machine tightness at initial start-up.

#### Apply Field Insulation if Required

Apply insulation as indicated in job data. If pressure gage reading (see paragraph above) indicates significant loss of machine vacuum, do not apply insulation. Contact your nearest Carrier Air Conditioning office as machine dehydration may be required.

Protect insulation from weld heat damage and weld splatter during installation.

### STEP 2 - INSTALL MACHINE SUPPORTS

#### Install Standard Isolation

Figures 1, 2 and 3 show positions of support plates and shear flex pads which together form the standard machine support system.

#### Install Special Isolation (if required)

Uneven floors or other considerations may dictate use of soleplates and leveling pads (Fig. 4 and 5).

Level machine by using jacking screws (Fig. 4) in isolation soleplates. Use 24-in. (600-mm) level (or longer). The unishell end flange and compressor support base may be used for leveling surface as indicated in Fig. 1.

Proper grout selection and placement is essential for adequate and long-lasting machine support. Carrier recommends that only epoxy-type grout be used for machine installation. Follow manufacturer's instructions in applying grout.

Table 1 — Rigging Weights\*

UNISHELL SIZE†	Weight	50	51	53	55	57	61	63	65	71	72	73	76	77	78
		lb	11,100	11,300	11,500	11,700	11,900	15,100	15,400	15,600	17,100	17,300	17,600	18,100	18,500
kg	5,000	5,100	5,200	5,300	5,400	6,800	7,000	7,000	7,700	7,800	7,900	8,200	8,300	8,500	

\*For machines with factory-mounted starter, add 1127 lbs (511 kg) (starter weight).

†See machine informative plate.

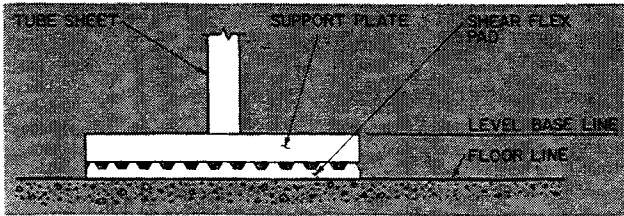
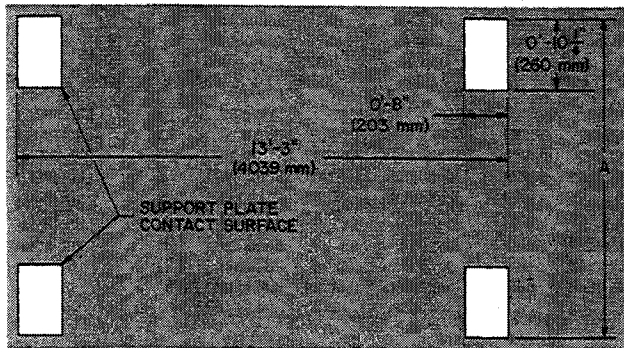

Fig. 2 — Standard Isolation



UNISHELL SIZE*	DIMENSION A	
	(ft-in.)	(mm)
50-57	3- 0	914
61-65	3-10	1168
66-78	4-6½	1384

\*See machine informative plate.

Fig. 3 — Standard Contact Surfaces

1. Check machine location prints for required grout thickness.
2. Carefully wax jacking screws for easy removal from grout.
3. Grout must extend above the base of the soleplate (Fig. 4) and there must be no voids in grout beneath the plates.
4. Allow grout to set and harden, per manufacturer's instructions, before starting machine.
5. Back jacking screws off leveling pads after grout has hardened.

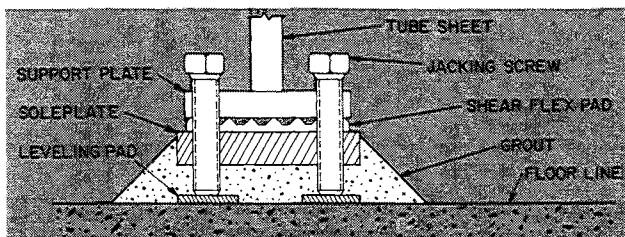
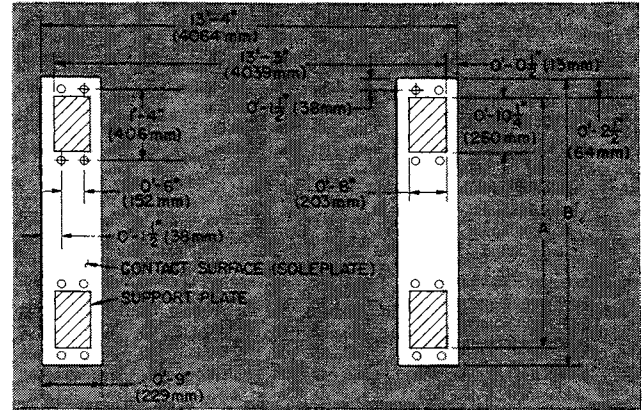

Fig. 4 — Machine Isolation with Soleplate Package



UNISHELL SIZE*	DIMENSIONS			
	A		B	
	(ft-in.)	(mm)	(ft-in.)	(mm)
50-57	3- 0	914	3-5	1041
61-65	3-10	1168	4-3	1295
66-78	4-6½	1384	4-11½	1511

\*See machine informative plate.

Fig. 5 — Contact Surfaces with Soleplates

### Install Spring Isolation

Field-purchased spring isolators may be placed directly under machine support plates as shown in Fig. 6 or may be located under machine soleplates. Consult job data for specific arrangement.

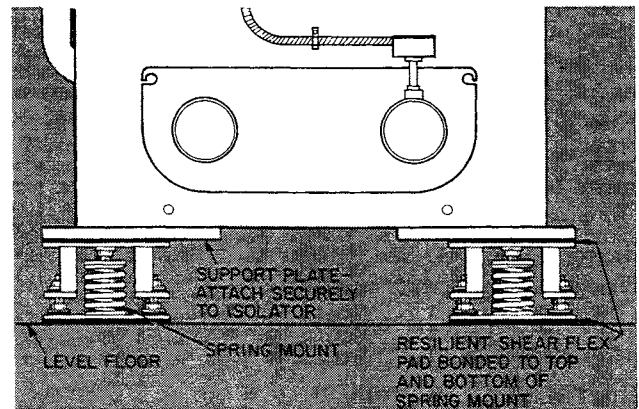

TYPICAL

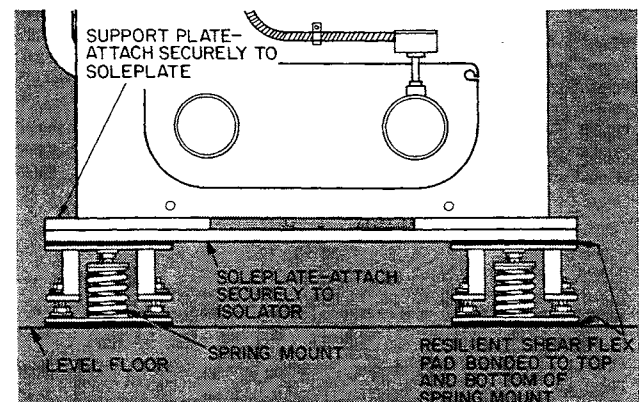

WITH SOLEPLATES

Fig. 6 — 19DM Spring Isolation

Obtain specific details on spring mounting and machine weight distribution from job data. Check job data also for methods of supporting and isolating piping attached to spring isolated machines.

### STEP 3 — MAKE PIPING CONNECTIONS

#### Install Water Piping to Heat Exchangers

Install piping per job data piping prints and details, and with provisions outlined below.

→ **CAUTION:** Water must be within design flow limits, clean and treated to ensure proper machine performance and reduce the potential of tubing damage due to corrosion, scaling or erosion. Carrier assumes no responsibility for chiller damage resulting from untreated or improperly treated water.

Factory-supplied insulation is not flammable but can be damaged by welding sparks and open flame. Protect insulation with an asbestos or wet canvas cover.

1. Remove chilled water control element (Fig. 1) before welding connecting piping to chilled water nozzle. Replace control element after welding is complete.
2. Offset pipe flanges to permit removal of water box covers for maintenance and to provide clearance for tube cleaning (Fig. 7). With marine water box option, no flanges are necessary; however, water piping should not cross in front of water box as access will be blocked off.
3. Provide openings in water piping for required pressure gages and thermometers (Fig. 7). For thorough mixing and temperature stabilization, wells in leaving water pipe should be placed 6 to 10 pipe diameters from the water box and should extend inside pipe at least 2 inches (50 mm).
4. Install air vents at all high points in piping to remove air and prevent water hammer.
5. Install pipe hangers where needed. There must be no weight or stress on water box nozzles or flanges.
6. Water flow direction must be as specified in job flow diagrams (see certified prints). Refer to Fig. 8.

*Incorrect water flow direction could prevent chiller from operating properly.*

7. Water flow switches must be of vaportight construction and must be installed at top of pipe in a horizontal run and at least 5 pipe diameters from any bend (Fig. 7).
8. Install water box vent and drain piping in accordance with individual job data. Vent and drain piping shown in Fig. 1 is typical only and may not conform to your arrangement. Vent and drain connection size is 3/4-in. FPT.

9. Install pipe plugs in unused water box drains and vent openings.

#### Install Water Piping to Oil Cooler (Fig. 10)

The oil pump starter and chiller lubrication assembly are protected against shipping damage by a metal guard (Fig. 9). Remove guard by loosening 4 bolts. Retighten bolts securely after guard removal.

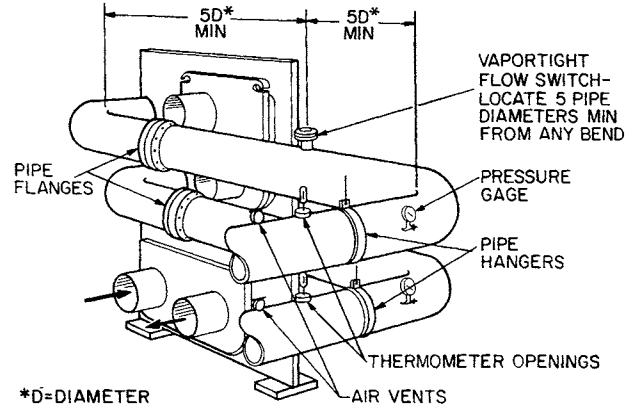

**Fig. 7 — Typical Nozzle Piping (Unit without Marine Water Box shown)**

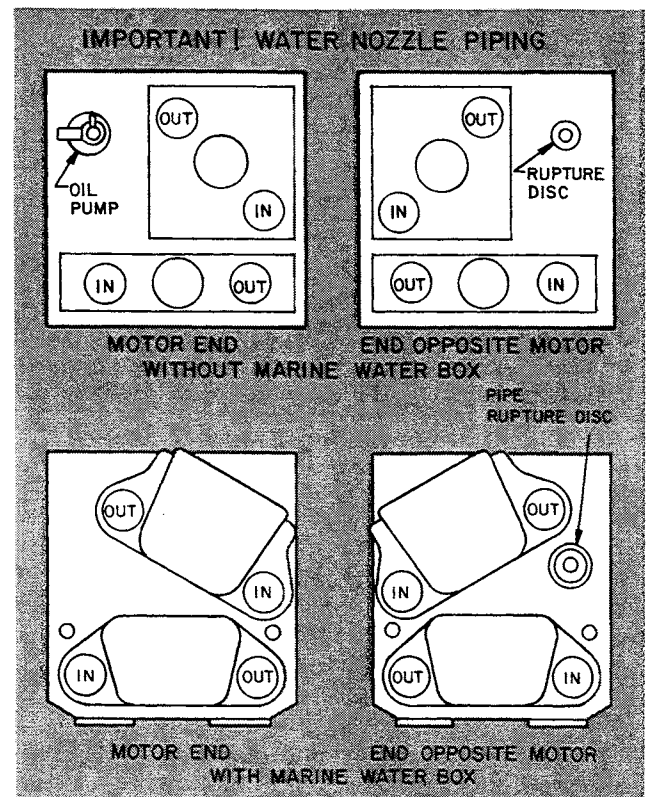

- IN** Nozzle in this position must be piped as *inlet* to heat exchanger.
- OUT** Nozzle in this position must be piped as *outlet* from this heat exchanger.
- Nozzle in this position may be inlet or outlet pipe according to job spec.

NOTE: This label is not intended to specify the machine nozzle arrangement. It is only to indicate which nozzles are *inlet* and *outlet*.

**Fig. 8 — Water Flow Direction**

A plug valve and solenoid valve subassembly (Fig. 10) has been disconnected from water-in side of oil cooler for shipping purposes. Remove shipping wrapper and reattach subassembly before adding field piping.

**Caution must be used when installing field piping to 1/2-in. SAE male flare oil cooler connections.**

A 1/2-in. flat is provided on fitting for a backup wrench to keep fitting from turning. Failure to hold fitting when tightening the connections results in twisting oil cooler piping internally, causing a flow restriction or leak.

Use city water or chilled water as specified in job data. Oil cooler water requirements are:

- Must be clean and noncorrosive.
- Max. inlet water temp ..... 85 F (30 C)
- Max. inlet working press. ... 200 psi (1379 kPa)
- Water flow, gpm (L/s) ..... 7 (.44) max,  
4 (.25) min
- Water press. drop, psi (kPa) diff ... 5 (35) max,  
2 (14) min

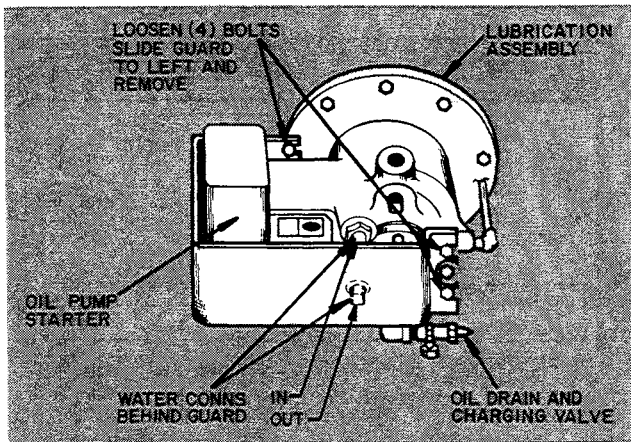

**Fig. 9 — Removing Shipping Guard**

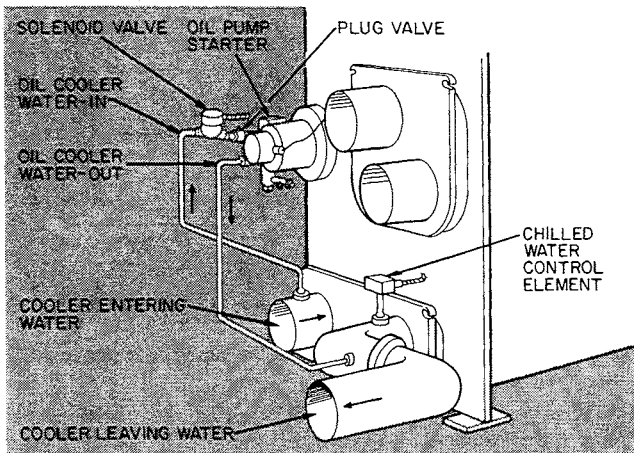

**Fig. 10 — Chilled Water to Oil Cooler Piping (Typical)**

If chilled water is used, pipe from entering chilled water line of machine cooler to entering (IN) connection on oil cooler. Water leaving oil cooler

drains into leaving water line of machine cooler (Fig. 10). Locate water drain connection downstream from chilled water control element as shown in Fig. 10 to prevent any interference with control temperature sensing.

If machine has a single-pass cooler, pipe oil cooler drain into suction side of the chilled water pump to ensure adequate pressure drop thru oil cooler.

If city water is used, pipe oil cooler leaving water into an open sight drain.

**Install Vent Piping to Relief Devices**

The 19DM chiller is factory equipped with a rupture disc assembly at end of unishell (see Fig. 1).

Vent relief device to the outdoors in accordance with ANSI/ASHRAE 15 (latest edition) Safety Code for Mechanical Refrigeration and all other applicable codes. *Refrigerant discharged into confined spaces can displace oxygen and cause asphyxiation.*

Remove shipping cap from the coupling on the rupture disc assembly. See chart below for pipe size.

UNISHELL SIZE	RUPTURE DISC PIPE SIZE	
	(in.)	(mm)
50-78	2	51

Add a flexible connection as required to eliminate any piping stress on rupture disc. Provide fittings so vent piping can be disconnected periodically for inspection of disc. Provide pipe plug on outlet side of relief device for leak testing.

Cover outdoor vent with a rain cap and place a condensation drain at the low point in vent piping to prevent water build-up on the atmospheric side of rupture disc.

**STEP 4 — MAKE ELECTRICAL CONNECTIONS**

**General**

Field wiring must be installed in accordance with job wiring diagrams and all applicable electrical codes.

Wiring schematics in this publication are for reference only and are not intended for actual installation; follow job wiring drawings.

**Do not attempt to start compressor, oil pump or purge motor even for a rotation check, nor apply test voltage of any kind while machine is under dehydration vacuum. Motor insulation breakdown and serious damage may result.**

**Install Compressor Power Wiring (not required for machines with factory-mounted starters)**

**ASSEMBLE TERMINAL BOX** — Assemble and install compressor terminal box after cutting necessary conduit openings in conduit support plates.

**ATTACH POWER LEADS** — Attach power leads to compressor terminals in accordance with job

wiring drawings, *observing caution label in terminal box*. Use only copper conductors. Ground motor in accordance with National Electrical Code and applicable local codes. Figure 11 illustrates one method of assembling multiple lead wires within compressor terminal box. For purposes of illustration, terminal insulation has been omitted.

Do not insulate terminals until wiring arrangement has been checked and approved by Carrier start-up personnel.

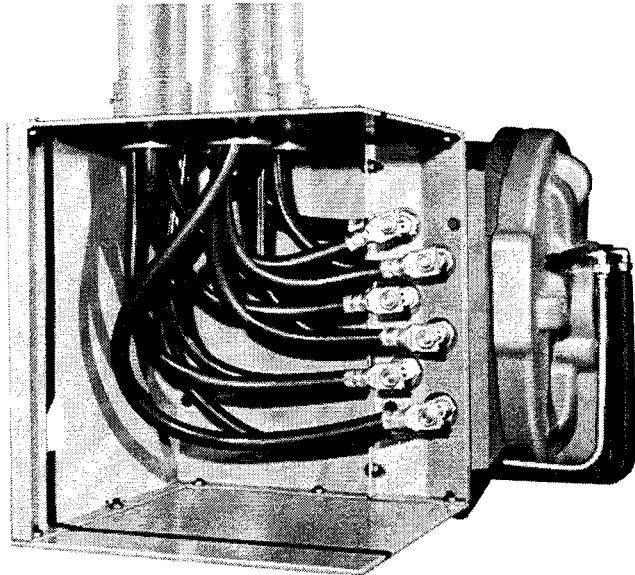

FRONT VIEW

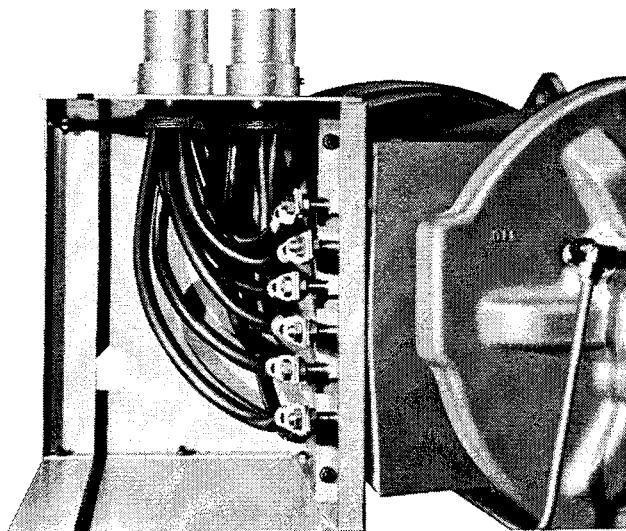

RIGHT END VIEW

**Fig. 11 — Typical Compressor Power Wiring (Less Terminal Insulation)**

**INSULATE MOTOR TERMINALS AND LEAD WIRE ENDS** — (Not required for machines with factory-mounted starter.) After confirmation of proper motor wiring by Carrier start-up personnel, insulate compressor motor terminals and lead wire ends thermally and electrically to prevent moisture condensation and electrical arcing. For low-voltage units (to 600 v), obtain insulation material, consist-

ing of 3 rolls of insulation putty and one roll of vinyl tape, from machine shipping package.

1. Thermally insulate each terminal by wrapping with one layer of insulation putty.
2. Overwrap putty with 4 layers of vinyl tape.

High-voltage units require special terminal preparation.

*Installer is responsible for any damage caused by improper wiring between starter and compressor motor.*

**Connect Power Wires to Oil Pump Starter (not required for machines with factory-mounted starter)**

Connect power wires to oil pump starter mounted on machine lubrication assembly (Fig. 1). Use separate fused disconnect as shown on job wiring drawings. Check that power supply voltage agrees with oil pump nameplate voltage. Typical wiring to an oil pump starter is shown schematically in Fig. 12.

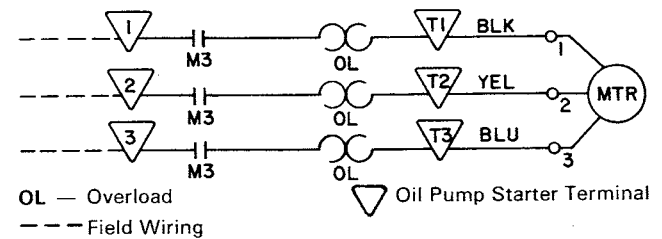

**Fig. 12 — Oil Pump Wiring Schematic (Typical)**

**Connect Power Wires to Oil Heater**

Use separate source and fused disconnect for power wiring to oil heater and thermostat. Wire per job drawings and wiring label on heater terminal box (see Fig. 1 for location). Figure 13 shows a typical wiring schematic.

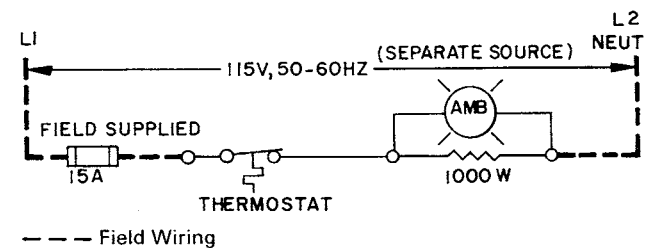

**Fig. 13 — Oil Heater Wiring Schematic (Typical)**

**Connect Wiring to Machine Control Center**

Connect control wiring from main motor starter, chilled and condenser water flow switches, water pumps, cooling tower and auxiliary equipment, if any, as indicated on job wiring drawings.

Also, make sure control circuit is grounded in accordance with applicable electrical codes and instructions on machine control schematic label. Be sure control circuit has a separate ground to the starter ground.

Manufacturer reserves the right to discontinue, or change at any time, specifications or designs without notice and without incurring obligations.

Book	2
Tab	5a

Form 19DM-1SIM New

Printed in U.S.A.

1090

3-84

PC 211

Catalog No. 531-958