

# Installation, Operating, and Maintenance Instructions

## SAFETY CONSIDERATIONS

Positive pressure storage systems are designed to provide safe and reliable service when operated within design specifications. When operating this equipment, use good judgment and safety precautions to avoid damage to equipment and property or injury to personnel.

Installation, start-up, and servicing of this equipment can be hazardous due to system pressures, electrical components, and equipment location (roofs, elevated structures, etc.). Only trained, qualified installers and service technicians should install, start up, and service this equipment.

Be sure you understand and follow the procedures and safety precautions contained in this guide.

### DANGER

Failure to follow these procedures will result in severe personal injury or death.

DO NOT VENT refrigerant relief valves within a building. Outlet from rupture disc or relief valve must be vented outdoors in accordance with the latest edition of ASHRAE 15 (American Society of Heating, Refrigerating, and Air-Conditioning Engineers). The accumulation of refrigerant in an enclosed space can displace oxygen and cause asphyxiation.

PROVIDE adequate ventilation in accordance with ASHRAE 15, especially for enclosed and low overhead spaces. Inhalation of high concentrations of vapor is harmful and may cause heart irregularities, unconsciousness, or death. Misuse can be fatal. Vapor is heavier than air and reduces the amount of oxygen available for breathing. Product causes eye and skin irritation. Decomposition products are hazardous.

DO NOT USE OXYGEN to purge lines or to pressurize a machine for any purpose. Oxygen gas reacts violently with oil, grease, and other common substances.

NEVER EXCEED specified test pressures, VERIFY the allowable test pressure by checking the instruction literature and the design pressures on the equipment nameplate.

DO NOT USE air for leak testing. Use only tracer gases and dry nitrogen.

DO NOT VALVE OFF any safety device.

BE SURE that all pressure relief devices are properly installed and functioning before operating any machine.

### WARNING

Failure to follow these procedures may result in personal injury or death.

DO NOT USE TORCH to remove any component. System contains oil and refrigerant under pressure.

To remove a component, wear protective gloves and goggles and proceed as follows:

- a. Shut off electrical power to unit.
- b. Recover refrigerant to relieve all pressure from system using both high-pressure and low-pressure ports.
- c. Traces of vapor should be displaced with nitrogen and the work area should be well ventilated. Refrigerant in contact with an open flame produces toxic gases.
- d. Cut component connection tubing with tubing cutter, and remove component from unit. Use a pan to catch any oil that may come out of the lines and as a gage for how much oil to add to the system.
- e. Carefully unsweat remaining tubing stubs when necessary. Oil can ignite when exposed to torch flame.

DO NOT USE eyebolts or eyebolt holes to rig machine sections or the entire assembly.

DO NOT work on high-voltage equipment unless you are a qualified electrician.

DO NOT WORK ON electrical components, including control panels, switches, starters, or oil heater until you are sure ALL POWER IS OFF and no residual voltage can leak from capacitors or solid-state components.

LOCK OPEN AND TAG electrical circuits during servicing. IF WORK IS INTERRUPTED, confirm that all circuits are de-energized before resuming work.

AVOID SPILLING liquid refrigerant on skin or getting it into the eyes. USE SAFETY GOGGLES. Wash any spills from the skin with soap and water. If any enters the eyes, IMMEDIATELY FLUSH EYES with water and consult a physician.

NEVER APPLY an open flame or live steam to a refrigerant cylinder. Dangerous overpressure can result. When necessary to heat refrigerant, use only warm (110 F [43 C]) water.

DO NOT REUSE disposable (nonreturnable) cylinders or attempt to refill them. It is DANGEROUS AND ILLEGAL. When cylinder is emptied, evacuate remaining gas pressure, loosen the collar and unscrew and discard the valve stem. DO NOT INCINERATE.

*(Warnings continued on next page.)*

**⚠ WARNING**

CHECK THE REFRIGERANT TYPE before transferring refrigerant to the machine. The introduction of the wrong refrigerant can cause damage or malfunction to this machine.

Operation of this equipment with refrigerants other than those cited herein should comply with ASHRAE 15 (latest edition). Contact Carrier for further information on use of this machine with other refrigerants.

ENSURE that refrigerant is only pumped to or stored in tanks that are ASME (American Society of Mechanical Engineers) certified for the pressures appropriate to the refrigerant being handled.

DO NOT ATTEMPT TO REMOVE fittings, covers, etc., while machine is under pressure or while machine is running. Be sure pressure is at 0 psig (0 kPa) before breaking any refrigerant connection.

CAREFULLY INSPECT all relief devices, rupture discs, and other relief devices AT LEAST ONCE A YEAR. If machine operates in a corrosive atmosphere, inspect the devices at more frequent intervals.

DO NOT ATTEMPT TO REPAIR OR RECONDITION any relief device when corrosion or build-up of foreign material (rust, dirt, scale, etc.) is found within the valve body or mechanism. Replace the device.

DO NOT install relief devices in series or backwards.

USE CARE when working near or in line with a compressed spring. Sudden release of the spring can cause it and objects in its path to act as projectiles.

**⚠ CAUTION**

Failure to follow these procedures may result in personal injury or damage to equipment.

EQUIPMENT should be operated by certified personnel only.

DO NOT STEP on refrigerant lines. Broken lines can whip about and cause personal injury and damage to the machine.

DO NOT climb over a machine. Use platform, catwalk, or staging. Follow safe practices when using ladders.

USE MECHANICAL EQUIPMENT (crane, hoist, etc.) to lift or move inspection covers or other heavy components. Even if components are light, use such equipment when there is a risk of slipping or losing your balance.

BE AWARE that certain automatic start arrangements CAN ENGAGE THE STARTER. Open the disconnect ahead of the starter in addition to shutting off the machine or pump.

USE only repair or replacement parts that meet the code requirements of the original equipment.

DOUBLE-CHECK that coupling nut wrenches, dial indicators, or other items have been removed before rotating any shafts.

DO NOT LOOSEN a packing gland nut before checking that the nut has a positive thread engagement.

PERIODICALLY INSPECT all valves, fittings, and piping for corrosion, rust, leaks, or damage.

DO NOT MIX REFRIGERANT from chillers that use different compressor oils. Compressor damage can result.

*(Cautions continued in next column.)*

**⚠ CAUTION**

DO NOT re-use compressor oil or any oil that has been exposed to the atmosphere. Dispose of oil per local codes and regulations.

DO NOT leave refrigerant system open to air any longer than the actual time required to service the equipment. Seal circuits being serviced and charge with dry nitrogen to prevent oil contamination when timely repairs cannot be completed.

**CONTENTS**

	Page
<b>SAFETY CONSIDERATIONS</b> .....	1,2
<b>INTRODUCTION</b> .....	2,3
<b>INSTALLATION</b> .....	3-10
<b>Step 1 — Complete Pre-Installation Checks</b> .....	3
• IDENTIFY UNIT	
• INSPECT SHIPMENT	
<b>Step 2 — Mount the Pumpout Unit</b> .....	3
• MOUNTING ON THE CHILLER	
• FLOOR MOUNTING	
<b>Step 3 — Rig the Storage Tank</b> .....	4
<b>Step 4 — Make Piping Connections</b> .....	6
• INSTALL VENT PIPING TO RELIEF DEVICES	
<b>Step 5 — Make Electrical Connections</b> .....	6
<b>CONTROLS AND COMPONENTS</b> .....	11
<b>Pumpout Unit</b> .....	11
• CONTROLS	
• SAFETY CONTROL SETTINGS	
• COMPRESSOR	
• CONDENSER	
• OIL SEPARATOR	
• SUCTION AND DISCHARGE VALVES	
<b>Storage Tank</b> .....	11
• DRAIN VALVE	
• DUAL RELIEF VALVES	
• PRESSURE GAGE	
• LEVEL GAGE	
<b>OPERATION</b> .....	11-17
<b>Overview</b> .....	11
• REFRIGERANT TRANSFER	
• TRANSFERRING LIQUID REFRIGERANT FROM THE CHILLER COOLER TO THE CHILLER CONDENSER OR PUMPOUT STORAGE TANK	
• TRANSFERRING LIQUID REFRIGERANT FROM THE CHILLER CONDENSER OR PUMPOUT STORAGE TANK TO THE CHILLER COOLER	
• DISTILLING THE REFRIGERANT	
<b>Pumpout and Refrigerant Transfer Procedures</b> .....	11
• PREPARATION	
• OPERATING THE PUMPOUT UNIT	
<b>MAINTENANCE</b> .....	17
<b>Pumpout Compressor Oil Charge</b> .....	17
<b>Storage Tank</b> .....	17
<b>Ordering Replacement Parts</b> .....	17
<b>TROUBLESHOOTING</b> .....	17,18

**INTRODUCTION**

The 19XR Positive Pressure Storage (PPS) system has been designed to help owners and operators of positive pressure chillers store HFC-134a refrigerant during service and repair work. The 19XR system conserves this refrigerant and prevents the release of excessive amounts of refrigerant into the

atmosphere. The proper use of this equipment minimizes the loss of HFCs.

The 19XR PPS system shown in Fig. 1 consists of a pump-out unit mounted on a storage tank. The pumpout unit is offered as a free-standing unit that can be used with chillers that have an existing storage tank or with chillers that have isolation valves that permit built-in refrigerant storage.

The 19XR PPS systems are factory tested and certified to the American Society of Mechanical Engineers (ASME) pressure vessel code. The tanks are constructed of certified steel and are pressure rated at 185 psig (1276 kPa). The PPS storage tank is equipped with dual relief valves for proper venting per ASHRAE 15 (American Society of Heating, Refrigerating, and Air-Conditioning Engineers) guidelines. An automatic level switch is prewired to the control circuit to ensure proper storage levels.

The 19XR pumpout unit is a complete, hermetic, compact unit that consists of:

- a hermetic reciprocating compressor with a direct-drive motor.
- a water-cooled refrigerant condenser.
- an oil separator.
- suction and discharge valves to control refrigerant flow.
- prewired safety and control devices.

## INSTALLATION

### Step 1 — Complete Pre-Installation Checks

**IDENTIFY UNIT** — Identify the assembly number (see Table 1) printed on the pumpout unit and storage tank nameplates. Check this information against the job requirements. Figure 1 shows the PPS system and its major components. Refer to Tables 2 and 3 for physical data.

**INSPECT SHIPMENT** — Inspect unit for damage before removing unit from shipping conveyance. If unit appears damaged, it should be inspected by a shipping inspector before removal. File a claim with the shipping company if shipment is damaged or incomplete. The manufacturer is not responsible for damage incurred during transit.

Check all components. Notify the supplier immediately if any item is missing. To prevent loss or damage, leave all parts in their original package until they are needed.

**Step 2 — Mount the Pumpout Unit** — The pumpout unit, if purchased separately, may be mounted directly on the chiller or it may be floor mounted.

**MOUNTING ON THE CHILLER** — See instructions provided with the chiller for mounting the pumpout unit. A typical chiller mount is shown in Fig. 2.

**FLOOR MOUNTING** — Select a ventilated and accessible area, free of traffic or other hazards. Remove and discard the 4 angle supports at the base of the pumpout unit and bolt the unit to the floor through the holes at the base of the pumpout unit. Special isolation is unnecessary. Contact surface and dimensions for the pumpout unit are given in Fig. 3.

**Table 1 — Positive Pressure System Assembly Numbers (R-134a)**

PUMPOUT SYSTEM ARRANGEMENT NUMBER	PUMPOUT UNIT ASSEMBLY NUMBER	COMPRESSOR MOTOR (V-PH-Hz)	MAXIMUM RLA	LRA	STORAGE TANK
19XR04027401	19XR04035801	208/230-3-50/60	15.8	105.0	28 cu ft (0.8 cu m)
19XR04027402	19XR04035802	460-3-60	7.8	52.0	28 cu ft (0.8 cu m)
19XR04027403	19XR04035803	400-3-50	7.8	52.0	28 cu ft (0.8 cu m)
19XR04027501	19XR04035801	208/230-3-50/60	15.8	105.0	52 cu ft (1.5 cu m)
19XR04027502	19XR04035802	460-3-60	7.8	52.0	52 cu ft (1.5 cu m)
19XR04027503	19XR04035803	400-3-50	7.8	52.0	52 cu ft (1.5 cu m)
19XR04026801	19XR04035801	208/230-3-50/60	15.8	105.0	Free-standing
19XR04026802	19XR04035802	460-3-60	7.8	52.0	Free-standing
19XR04026803	19XR04035803	400-3-50	7.8	52.0	Free-standing
19XR14017801	19XR04035801	208/230-3-50/60	15.8	105.0	Unit-mounted, frame 1
19XR14017802	19XR04035802	460-3-60	7.8	52.0	Unit-mounted, frame 1
19XR14017803	19XR04035803	400-3-50	7.8	52.0	Unit-mounted, frame 1
19XR34017801	19XR04035801	208/230-3-50/60	15.8	105.0	Unit-mounted, frame 2 or 3
19XR34017802	19XR04035802	460-3-60	7.8	52.0	Unit-mounted, frame 2 or 3
19XR34017803	19XR04035803	400-3-50	7.8	52.0	Unit-mounted, frame 2 or 3
19XR44017801	19XR04035801	208/230-3-50/60	15.8	105.0	Unit-mounted, frame 4
19XR44017802	19XR04035802	460-3-60	7.8	52.0	Unit-mounted, frame 4
19XR44017803	19XR04035803	400-3-50	7.8	52.0	Unit-mounted, frame 4
19XR54017801	19XR04035801	208/230-3-50/60	15.8	105.0	Unit-mounted, frame 5
19XR54017802	19XR04035803	460-3-60	7.8	52.0	Unit-mounted, frame 5
19XR54017803	19XR04035803	400-3-50	7.8	52.0	Unit-mounted, frame 5
19XR64017801	19XR04035801	208/230-3-50/60	15.8	105.0	Unit-mounted, frame 6
19XR64017802	19XR04035802	460-3-60	7.8	52.0	Unit-mounted, frame 6
19XR64017803	19XR04035803	400-3-50	7.8	52.0	Unit-mounted, frame 6
19XR74017801	19XR04035801	208/230-3-50/60	15.8	105.0	Unit-mounted, frame 7
19XR74017802	19XR04035802	460-3-60	7.8	52.0	Unit-mounted, frame 7
19XR74017803	19XR04035803	400-3-50	7.8	52.0	Unit-mounted, frame 7
19XR84017801	19XR04035801	208/230-3-50/60	15.8	105.0	Unit-mounted, frame 8
19XR84017802	19XR04035802	460-3-60	7.8	52.0	Unit-mounted, frame 8
19XR84017803	19XR04035803	400-3-50	7.8	52.0	Unit-mounted, frame 8

LEGEND

- LRA — Locked Rotor Amps  
RLA — Rated Load Amps

NOTES:

1. All storage vessels are 185 psig (1276 kPa) designs per the ASME (American Society of Mechanical Engineers) Boiler Pressure Vessel Code, Section VIII Division 1.
2. All units above are shipped with a 15 psig (103 kPa) nitrogen charge.
3. Nominal horsepower for all pumpout units is 3.0.

**Step 3 — Rig the Storage Tank** — The complete 19XR system can be rigged as a single assembly. See the rigging instructions on the label attached to the assembly. Also refer to the rigging guide (Fig. 4), physical data in Tables 2 and 3, and contact surface and dimensions for the complete system in Fig. 5. *Lift the assembly only from the 4 points indicated in the rigging guide.* Each rigging cable must be capable of supporting the entire weight of the assembly.

**WARNING**  
 Lifting the assembly from points other than those specified may result in serious damage to the assembly and personal injury. Rigging equipment and procedures must be adequate for assembly. See Tables 2 and 3 for weights. (These weights are broken down into pumpout unit and storage tank weights. For the complete assembly weight, add all components together.)

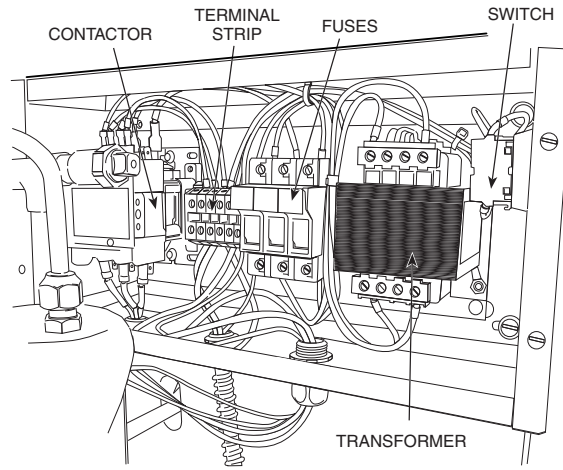
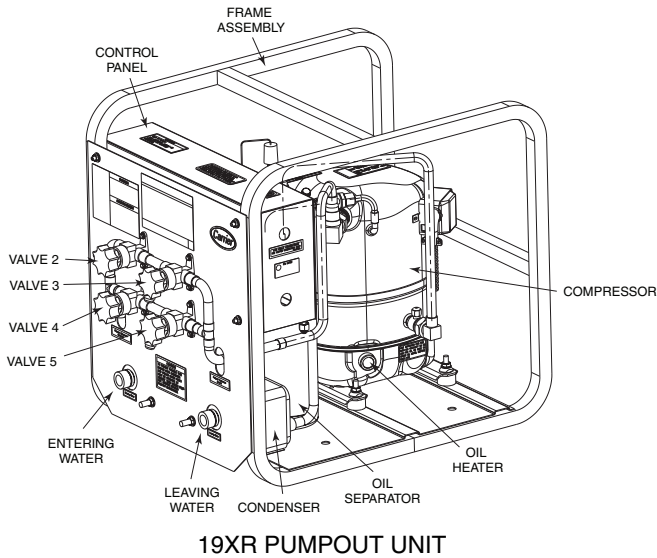

19XR PUMPOUT UNIT

19XR CONTROL BOX (INTERIOR)

**Fig.1 — 19XR Positive Pressure Storage System**

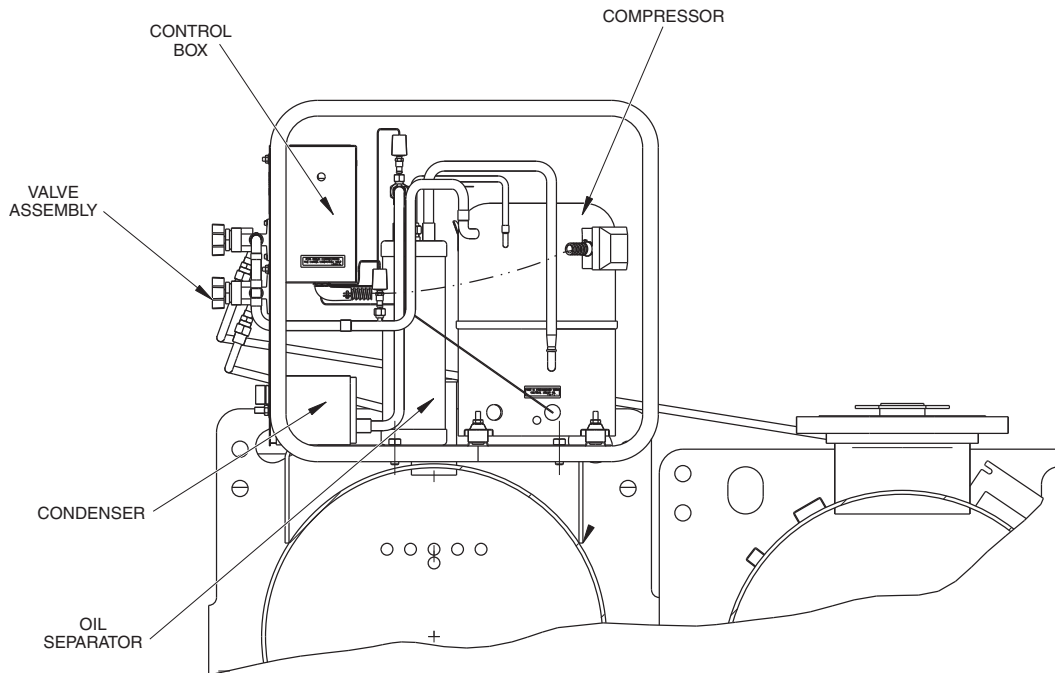

**Fig. 2 — 19XR Pumpout Unit: Typical Chiller Mount**

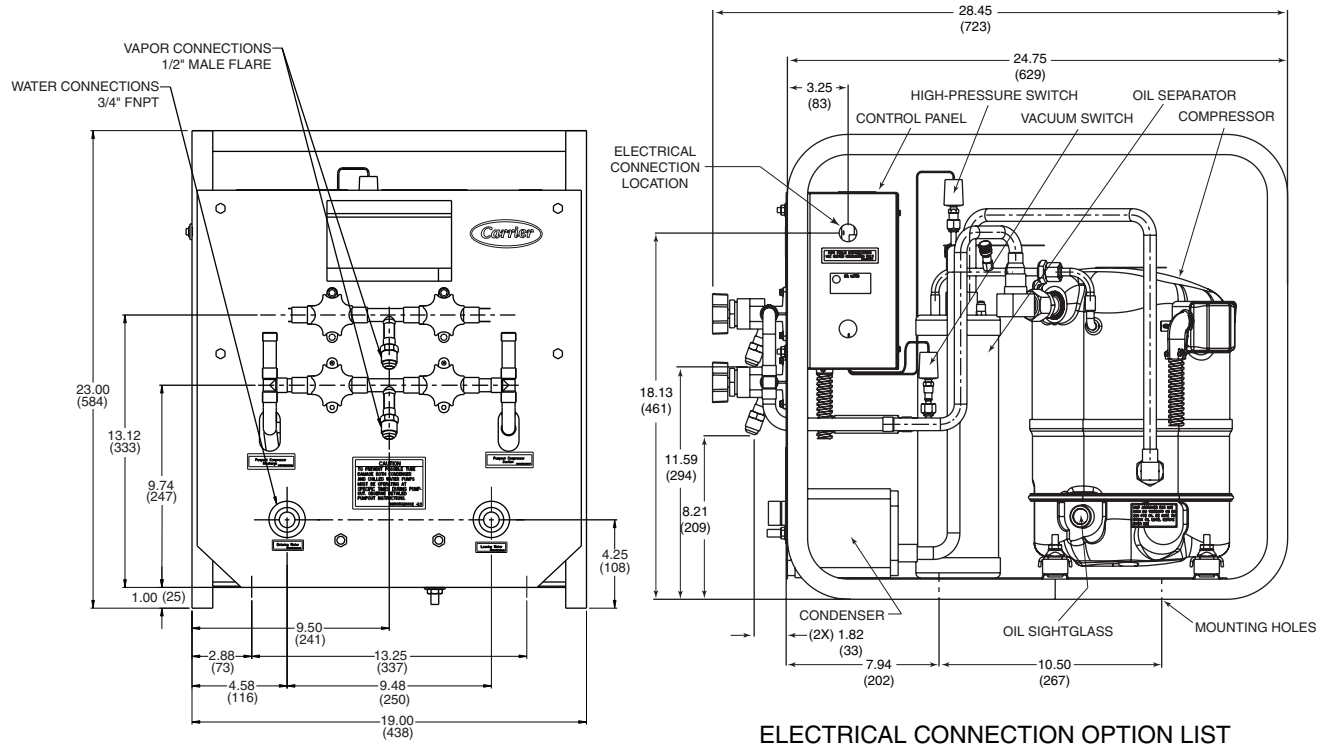

NOTE: Dimensions in inches (millimeters).

**ELECTRICAL CONNECTION OPTION LIST**

TRADE SIZE (in.)	QTY	LOCATION
1/2	1	TOP
3/4	1	BOTTOM
1	1	MIDDLE
1 1/4	1	MIDDLE

**Fig. 3 — Pumpout Unit Contact Surfaces and Dimensions**

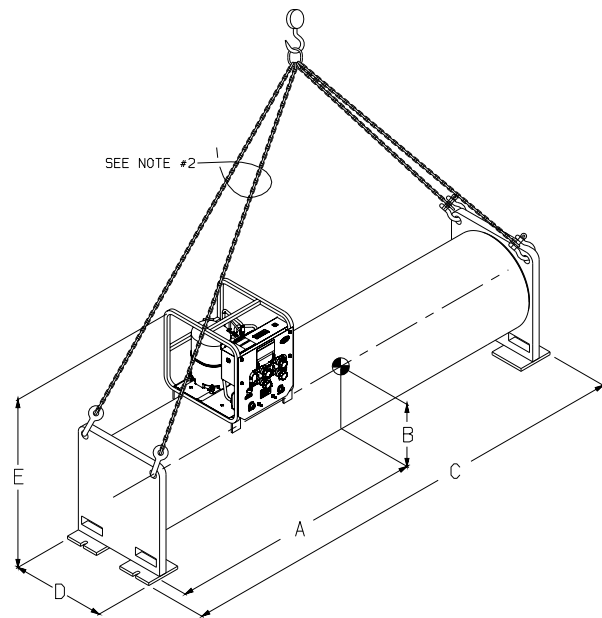

**NOTES:**

- Each chain must be capable of supporting the entire weight of the machine.
- Minimum chain length:  
 28 ft<sup>3</sup> (0.79 m<sup>3</sup>) tank — 10'-0" (3098 mm)  
 52 ft<sup>3</sup> (1.47 m<sup>3</sup>) tank — 15'-6" (4724 mm)

STORAGE TANK SIZE	CENTER OF GRAVITY DIMENSIONS (APPROX.) ft-in. (mm)		OVERALL DIMENSIONS (APPROX.) ft-in. (mm)			EMPTY WEIGHT lb (kg)
	A	B	C	D	E	
28 CU FT (0.8 CU M)	4-9 1/8 (1451)	1-7 7/8 (505)	10-5 (3175)	2-4 3/4 (730)	4-4 1/4 (1327)	2,385 (1082)
52 CU FT (1.5 CU M)	6-11 5/8 (2124)	1-8 3/4 (527)	14-11 1/4 (4553)	2-8 1/2 (826)	4-8 1/4 (1429)	3,415 (1549)

**Fig. 4 — Rigging Guide**

**Table 2 — Physical Data — 19XR Pumpout Unit**

		ENGLISH	SI
Pumpout Unit Weight*	lb (kg)	164	(75)
Pumpout Condenser Water Flow Rate	gpm (L/s)	7-9	(.45-.58)
Pumpout Condenser Water Pressure Drop	psig (kPa)	0.3	(2.0)
Maximum Entering Condenser Water Temperature	F (C)	85	(29)
Maximum Leaving Condenser Water Temperature	F (C)	100	(37)
Relief Valve	psig (kPa)	235	(1620)
Condenser Pressure Rating Refrigerant Side Waterside	psig (kPa) psig (kPa)	450 450	(3102) (3102)

\*The pumpout unit weight includes the compressor/condenser, control box, and the oil separator.

NOTES:

1. The motor is hermetic with thermal protection.

2. The control box is mounted and wired with an ON/OFF/AUTO switch according to NEMA 1 (National Electrical Manufacturing Association).
3. The starter contactor is located in the control box. The overloads on the motor are wired and the internal disconnect switch is supplied by the customer.

**Table 3 — 19XR Storage Tank Rated Dry Weight and Refrigerant Capacity**

SIZE cu ft (cu m)	TANK OD in. (mm)	DRY WEIGHT* lb (kg)	MAXIMUM REFRIGERANT CAPACITY LB (KG)	
			ASHRAE/ANSI 15	UL 1963
			R-134a	R-134a
28 (0.8)	24.00 (610)	2334 (1059)	1860 (844)	1716 (778)
52 (1.5)	27.25 (692)	3414 (1549)	3563 (1616)	3286 (1491)

LEGEND

- ANSI — American National Standards Institute  
 ASHRAE — American Society of Heating, Refrigeration, and Air-Conditioning Engineers  
 UL — Underwriters' Laboratories

\*The above dry weight includes the pumpout unit weight of 164 lb (75 kg).

**Step 4 — Make Piping Connections** — Figure 5 represents typical pumpout unit/chiller piping connections. Standard connections for 1/2-in. OD copper tubing are provided. Install the field-supplied FPT tee with pipe plug in the piping as shown in Fig. 5. This tee is used for refrigerant charging.

NOTE: If any field piping runs exceed 50 ft in length, use 7/8-in. OD copper tubing to minimize pressure drop.

Pumpout unit water piping connections are shown in Fig. 5. Both connections are 3/4-in. NPT (female). A shutoff valve should be installed in the water line. Provide a means for blowing water from the condenser coil at winter shutdown to prevent freeze-up damage. Refer to the Job Data for water piping particulars.

**INSTALL VENT PIPING TO RELIEF DEVICES** — The pumpout storage tank is factory-equipped with relief devices. Refer to Fig. 6 and Table 4 for size and location of the relief devices. Vent the relief devices to the outdoors in accordance with ANSI/ASHRAE 15 Safety Code (latest edition) for Mechanical Refrigeration and all other applicable codes. Pumpout unit relief devices are set to relieve at 235 psig (1620 kPa). Storage tank relief devices are set to relieve at 185 psig (1276 kPa).

1. If relief devices are manifolded, the cross-sectional area of the relief pipe must at least equal the sum of the areas required for individual relief pipes.
2. Provide a pipe plug near outlet side of each relief device for leak testing. Provide pipe fittings that allow vent piping to be disconnected periodically for inspection of valve mechanism.
3. Piping to relief devices must not apply stress to the device. Adequately support piping. A length of flexible tubing or piping near the device is essential on spring-isolated machines.
4. Cover the outdoor vent with a rain cap and place a condensation drain at the low point in the vent piping to prevent water build-up on the atmospheric side of the relief device.

**Step 5 — Make Electrical Connections** — See nameplate on compressor of pumpout unit and Table 1 for motor electrical data. Wire unit according to the diagram inside the control box.

Figure 7 is the wiring schematic for a complete system that includes the 19XR storage tank and the pumpout unit. Figure 8 is the wiring schematic for the pumpout unit. Use this schematic for installations that do not include an auxiliary pumpout storage tank.

NOTE: Use copper conductors only.

**⚠ DANGER**

Refrigerant discharged into confined spaces can displace oxygen and cause asphyxiation.

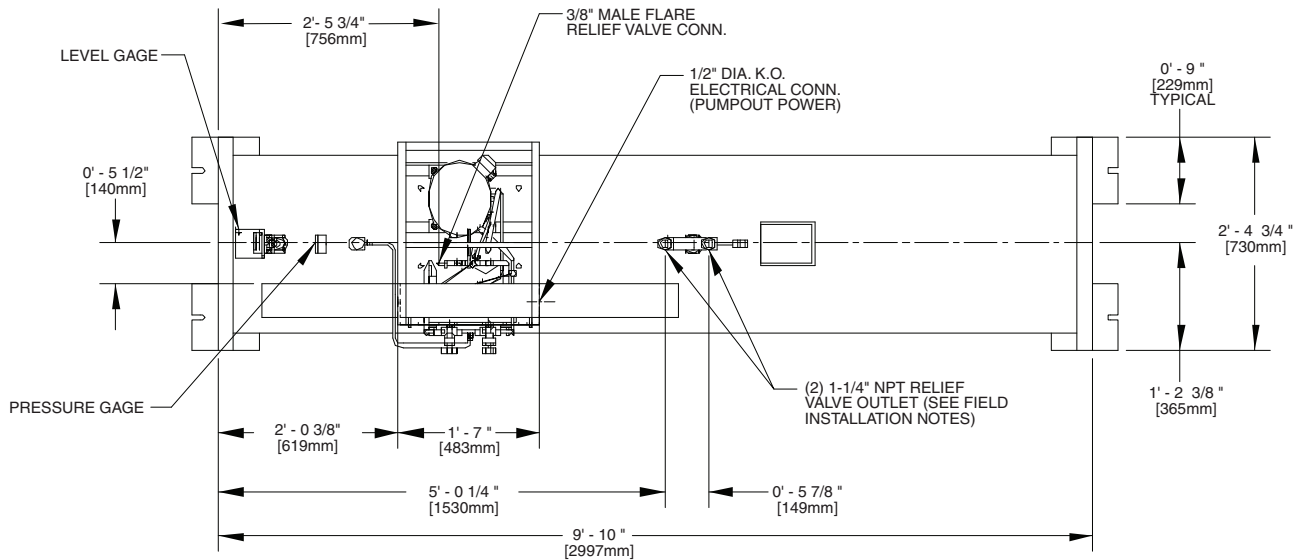

TOP VIEW

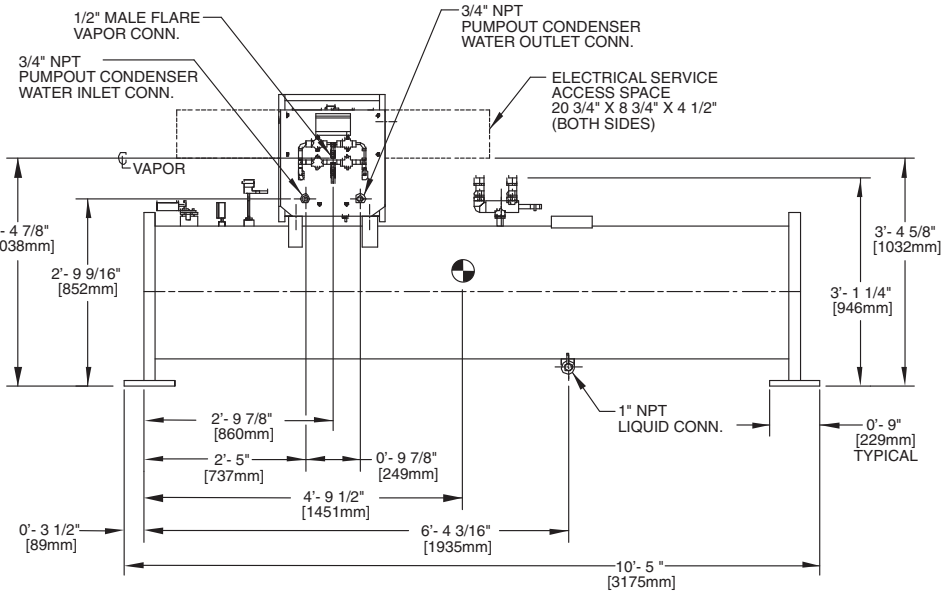

FRONT VIEW

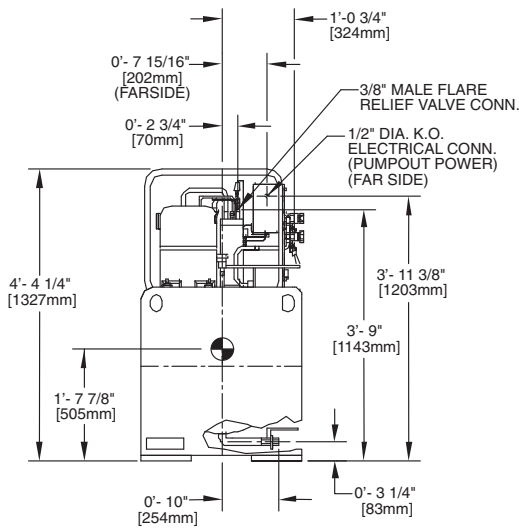

LEFT SIDE VIEW

NOTES:

1.  Denotes center of gravity.
2. Dimensions in [ ] are in millimeters.
3. The weights and center of gravity values given are for an empty storage tank.
4. For additional information on the pumpout unit, see certified drawings.
5. Conduit knockout is located on the side of the control box.
6. Storage tank weight: 2334 lb (1059 kg).

28 CU FT [0.8 CU METER] STORAGE TANK WITH PUMPOUT UNIT

Fig. 5 — Storage Tank with Pumpout Unit

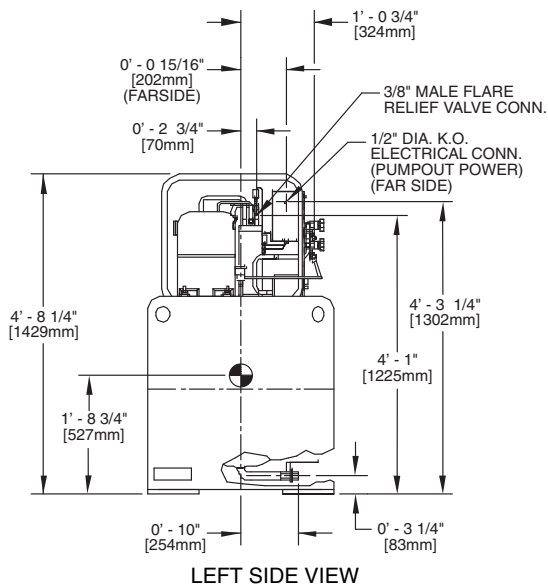
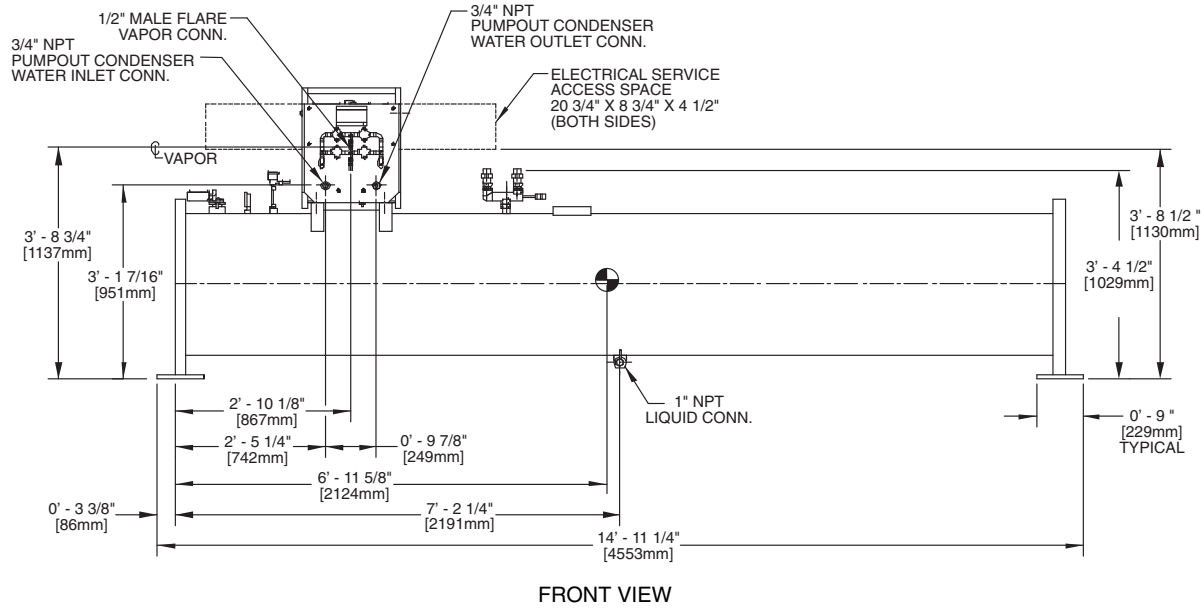
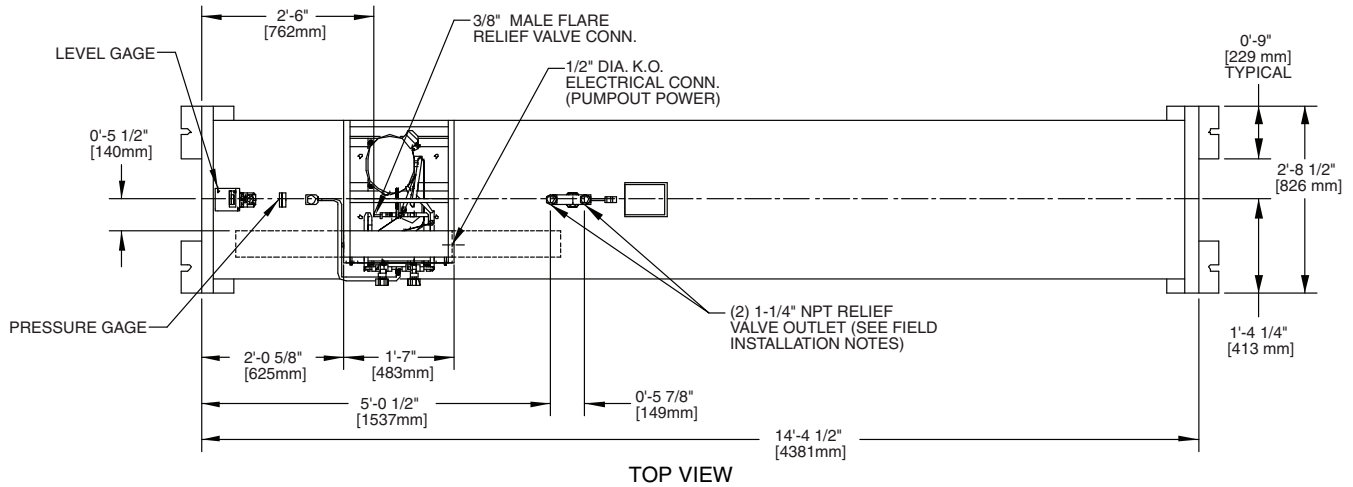

**NOTES:**

1.  Denotes center of gravity.
2. Dimensions in [ ] are in millimeters.
3. The weights and center of gravity values given are for an empty storage tank.
4. For additional information on the pumpout unit, see certified drawings.
5. Conduit knockout is located on the side of the control box.
6. Storage tank weight: 3414 lb (1549 kg).

52 CU FT [1.5 CU METER] STORAGE TANK WITH PUMPOUT UNIT

**Fig. 5 — Storage Tank with Pumpout Unit (cont)**



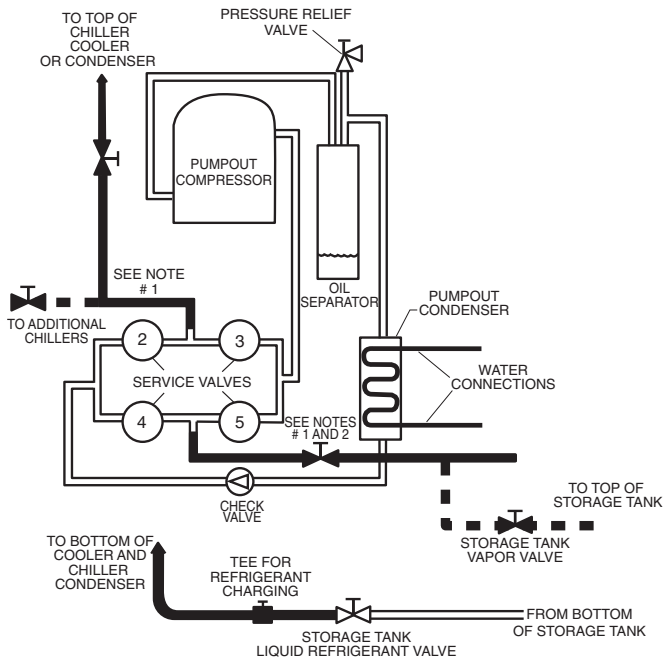

CHILLERS WITHOUT ISOLATION VALVES

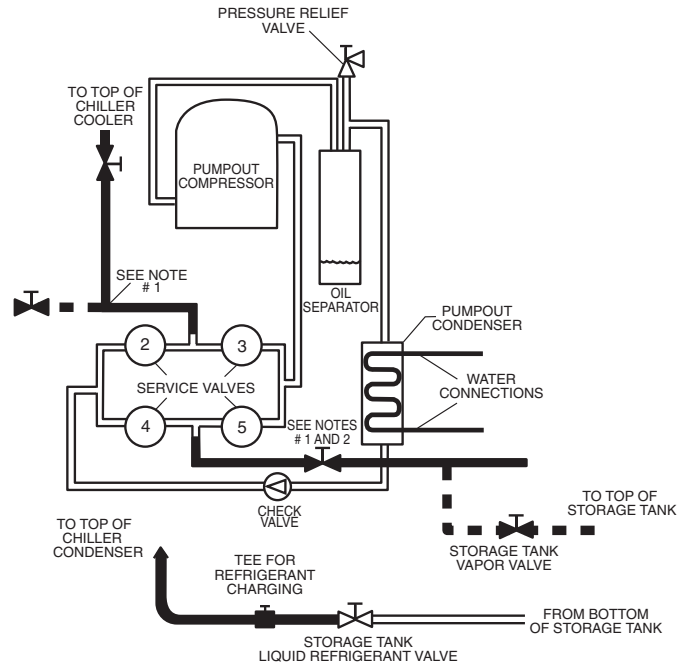

CHILLERS WITH ISOLATION VALVES  
(WITH OR WITHOUT PUMPOUT STORAGE TANKS)

GENERAL PIPING CONNECTION SIZES

CONNECTION	SIZE (in.)
Refrigerant Transfer Connections	1/2 Flare (male)
Condenser Water Cooling Connectors	3/4 NPT (female)
Safety Relief Head Pumpdown	3/8 Flare (male)

LEGEND

- Factory-Supplied Tubing
- Field-Supplied Tubing
- Field-Supplied Tubing (Multiple Chillers)
- Service Valve (Factory Supplied)
- Service Valve (Field Supplied)

NOTES:

- The field-supplied tubing is to be 1/2-in. OD tubing (min.) and must be arranged and supported to avoid stresses on the equipment, transmission of vibrations, and interference with routine access during the reading, adjusting, and servicing of the equipment. If the distance from the chiller to the pumpout unit is over 50 ft, then 7/8-in. OD tubing (min.) must be used. Provisions should be made for adjustment in each plane of the tubing and for both periodic and major servicing of the equipment. Special care must be taken so that the safety head does not experience tubing strain. Vent the safety head per ASHRAE 15 (American Society of Heating, Refrigerating, and Air-Conditioning Engineers), latest revision.
- The tubing and valve from the storage tank to the pumpout compressor is factory supplied when the unit is factory mounted.

Fig. 6 — Typical Pumpout Unit/Chiller Connection Schematic

Table 4 — Relief Devices

STORAGE TANK SIZE cu ft (cu m)	RELIEF VALVE OUTLET SIZE	QUANTITY	REQUIRED "C" FACTOR	
			lb air min	kg air min
28 (0.8)	1 1/4 in. NPT Female Connector	2	34.5	15.6
52 (1.5)	1 1/4 in. NPT Female Connector	2	52.3	23.7

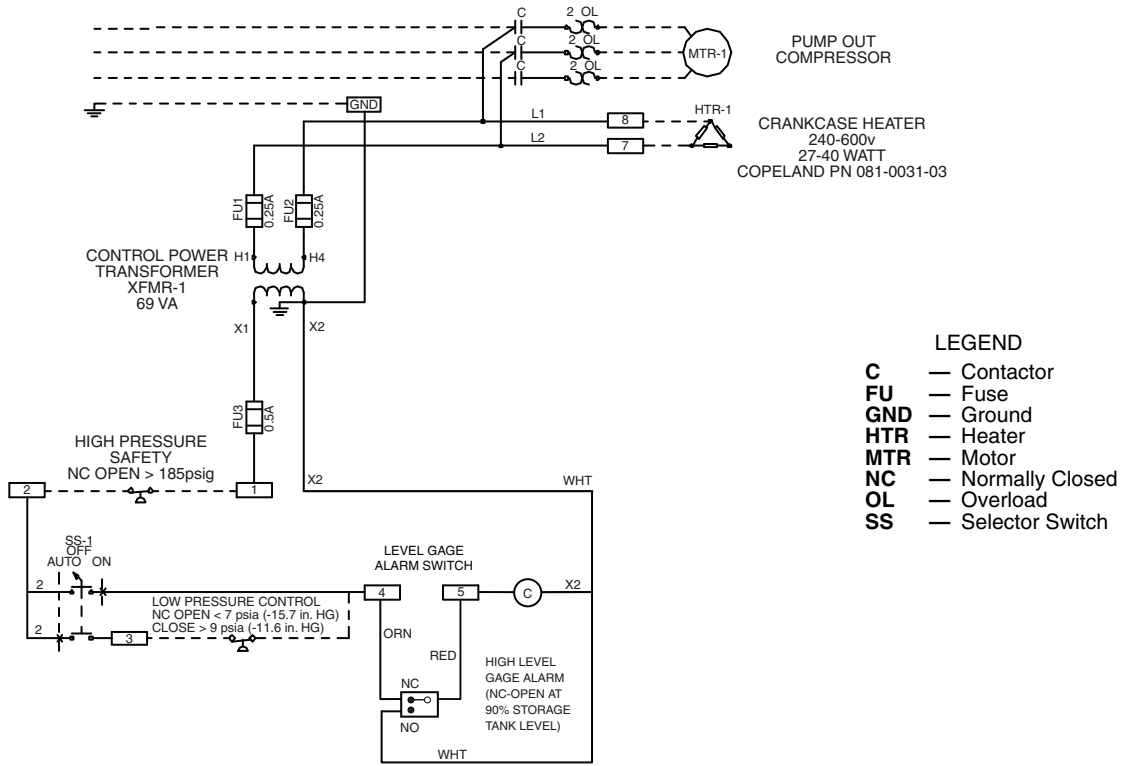

**Fig. 7 — 19XR Pumpout System Wiring Schematic**

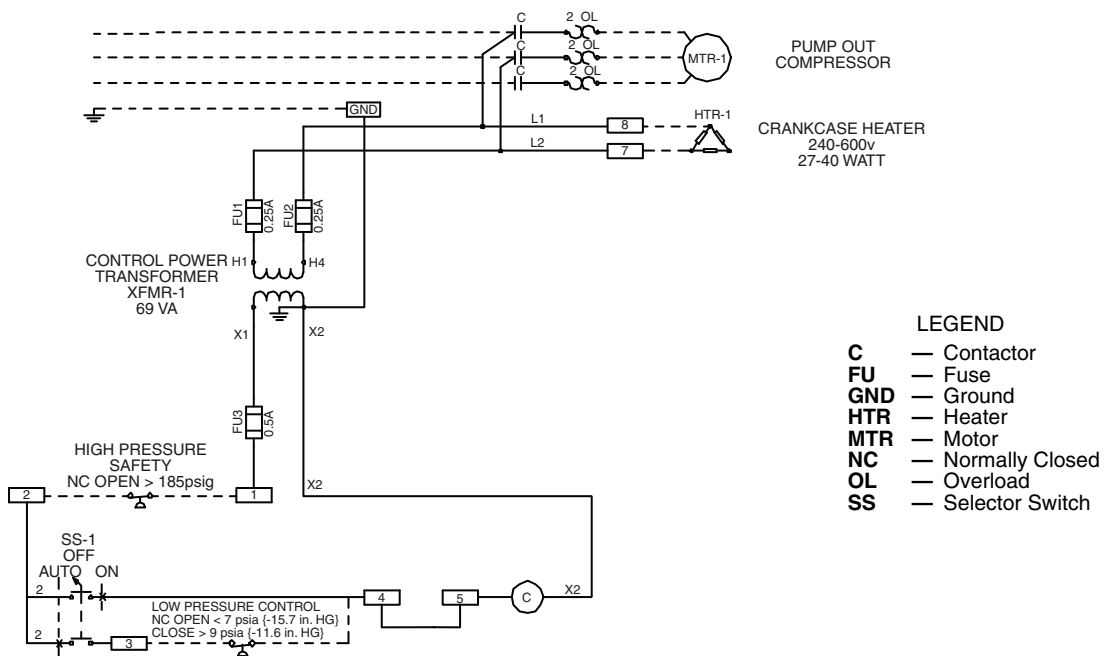

**Fig. 8 — Pumpout Unit Wiring Schematic**

## CONTROLS AND COMPONENTS

Figure 1 shows the major components of the PPS system.

**Pumpout Unit** — The pumpout unit consists of a hermetic reciprocating compressor, a water cooled refrigerant condenser, an oil separator, and prewired safety and control devices. The pumpout unit comes equipped with a 4-way transfer valve manifold to interconnect both liquid and vapor transfer and to pressurize the chiller during transfer of refrigerant from chiller to storage tank.

**CONTROLS** — The pumpout unit has the following controls: manual/off/automatic selector switch, transformer, .25 amp fuses for the primary side of the transformer, 5 amp fuse for the secondary side of the transformer, contactor, terminal strip, high pressure cutout switch and low pressure switch.

**SAFETY CONTROL SETTINGS** — The pumpout unit high-pressure switch (Fig. 3) is set to open at the settings listed in Table 5. The switch setting is checked by operating the pumpout condenser and slowly throttling the pumpout condenser water.

When the selector switch is in the Automatic position, the pumpout will cycle on a low pressure/vacuum switch. This switch will shut down the pumpout compressor when suction pressure reaches  $7 \pm 1.5$  psia or  $15 \pm 3$  in. Hg vacuum (51.7 kPa absolute). When the selector switch is in the On position, the pumpout compressor will continue to run until refrigerant vapor flow is so low that the compressor motor overheats. At this time the compressor motor overload will shut off the compressor. This is NOT recommended.

**Table 5 — High Pressure Switch Settings**

REFRIGERANT	HIGH-PRESSURE SWITCH	
	CUTOUT	CUT-IN
R-134a	$185 \pm 10$ psig ( $1276 \pm 69$ kPa)	$140 \pm 10$ psig ( $965 \pm 69$ kPa)

**COMPRESSOR** — The hermetic compressor assembly comes equipped with internal thermal protection on the motor and a self-regulating crankcase heater.

**CONDENSER** — The water-cooled condenser is a brazed plate heat exchanger. During transfer, it condenses refrigerant vapor to liquid.

**OIL SEPARATOR** — The pumpout unit includes an in-line oil separator to remove oil that becomes mixed with refrigerant and returns the oil to the compressor.

**SUCTION AND DISCHARGE VALVES** — The pumpout unit comes with a 4-way transfer valve manifold to interconnect both liquid and vapor transfer and to pressurize the chiller during transfer of refrigerant from chiller to storage tank or from one chiller vessel to another.

**Storage Tank** — The storage tank is rated for positive pressure refrigerants under ASME Section VIII pressure vessel codes with a minimum of 185 psig (1276 kPa) rating. The tank components include:

**DRAIN VALVE** — Located at its lowest point of drain with a minimum of 1 in. NPT.

**DUAL RELIEF VALVES** — Two relief valves and a 3-way shut-off valve.

**PRESSURE GAGE** — A 30 in. Hg vacuum -0-400 psig (101-0-2760 kPa) compound pressure gage.

**LEVEL GAGE** — Liquid level gage (magnetically coupled dial type) with electronic shut-off at 90% liquid capacity.

### WARNING

During transfer of refrigerant into and out of the pumpout storage tank, carefully monitor the storage tank level gage. Do not fill the tank more than 90% of capacity to allow for refrigerant expansion. Overfilling may result in damage to the tank and personal injury. For maximum refrigerant capacity, refer to Table 3.

## OPERATION

**Overview** — Transferring refrigerant from one vessel to another is accomplished by using either gravity or pressure differential. A difference in elevation between 2 vessels results in a gravity flow of liquid; a difference in pressure forces the liquid from one vessel to the other. The latter method requires lowering the pressure in one vessel. If there is liquid in that vessel, its temperature must be lowered, and the pressure in the other vessel must be simultaneously increased.

Under most circumstances, creating the pressure differential is not a difficult process. Some applications, such as ice storage, outdoor installations, or installations with high temperature differentials between the storage tank and the chiller may require additional consideration. In some instances, it may be necessary to add auxiliary heat to one of the vessels or to insulate the storage tank at job sites where high ambient temperature or sun load make it difficult to reduce the temperature and pressure in the tank. Outdoor installations must have a roof or cover over the storage tank to ensure that the pressure in the tank does not exceed the chiller relief pressure setting.

**REFRIGERANT TRANSFER** — When refrigerant is being evacuated from the chiller cooler or condenser vessels, any liquid refrigerant left in a vessel will flash off, lowering the temperature in that vessel enough to freeze the fluid (usually water) flowing through the cooler or condenser tubes. This event, called tube freeze-up, can cause extensive damage to the chiller; therefore, all liquid refrigerant must be removed from a vessel before evacuation of refrigerant vapor is started. If all the liquid cannot be removed, then the cooler water and condenser water pumps must be operated throughout the process of evacuating refrigerant vapor to keep fluid moving through the cooler and condenser tubes.

**TRANSFERRING LIQUID REFRIGERANT FROM THE CHILLER COOLER TO THE CHILLER CONDENSER OR PUMPOUT STORAGE TANK** — Chiller and pumpout unit valves are set to permit the pumpout compressor to discharge refrigerant vapor into the cooler vessel, lowering pressure in the condenser vessel/storage tank. The pressure differential forces liquid from the cooler vessel into the condenser vessel/storage tank. After all the liquid is transferred, the refrigerant vapor remaining in the cooler vessel can be drawn off by reducing pressure in the chiller and discharging the vapor through the pumpout unit condenser into the condenser vessel/storage tank.

**NOTE:** The pumpout selector switch can be placed in On or Automatic mode. In Automatic mode, the compressor will shut off automatically once the suction pressure drops to 7 psia or 15 in. Hg vacuum (51.7 kPa absolute). In On mode, the unit will continue to pumpout regardless of the suction (vacuum) pressure.

**TRANSFERRING LIQUID REFRIGERANT FROM THE CHILLER CONDENSER OR PUMPOUT STORAGE TANK TO THE CHILLER COOLER** — Chiller and pumpout unit valves are set to increase pressure in the chiller condenser vessel/storage tank and to reduce pressure in the cooler vessel. Pressure in the cooler vessel is lowered to correspond to a saturated refrigerant liquid temperature  $2^\circ\text{F}$  ( $1.1^\circ\text{C}$ ) above the freezing temperature of the liquid circulating through the chiller cooler/condenser tubes ( $34\text{ F}$  [ $1.1\text{ C}$ ] for water). The valves are set so that the pressure in the cooler vessel is lower than that of the condenser vessel/storage tank, forcing the liquid into the cooler vessel.

**NOTE:** The pumpout selector switch can be placed in On or Automatic mode. In Automatic mode, the compressor will shut off automatically once the suction pressure drops to 7 psia or 15 in. Hg vacuum (51.7 kPa absolute). In On mode, the unit will continue to pumpout regardless of the suction (vacuum) pressure.

NOTE: During this operation, maintain water circulation through the chiller cooler and condenser vessels to prevent tube freeze-up.

**DISTILLING THE REFRIGERANT** — Refrigerant vapor is transferred from the chiller cooler vessel or pumpout storage tank through the pumpout condenser, condensed to a liquid, and pumped to the chiller condenser vessel. During this operation, water circulation must be maintained in the pump-out condenser. Refrigerant impurities left in the chiller cooler vessel or storage tank are then drained off. This operation can take from 4 to 14 hours, depending on the type and amount of refrigerant being distilled.

The Pumpout and Refrigerant Transfer Procedures section gives step-by-step instructions on performing these operations.

## Pumpout and Refrigerant Transfer Procedures

**PREPARATION** — The 19XR chiller may come equipped with an optional pumpout storage tank, pumpout system, or pumpout compressor. The refrigerant can be pumped for service work to either the chiller compressor vessel or chiller condenser vessel by using the optional pumpout system. If a pumpout storage tank is supplied, the refrigerant can be isolated in the storage tank. The following procedures describe how to transfer refrigerant from vessel to vessel and perform chiller evacuation.

### ⚠ CAUTION

The power to the pumpout compressor oil heater must be on whenever any valve connecting the pumpout compressor to the chiller or storage tank is open. Leaving the heater off will result in oil dilution by refrigerant and can lead to compressor failure.

If the compressor is found with the heater off and a valve open the heater must be on for at least 4 hours to drive the refrigerant from the oil. When heating the oil the compressor suction must be open to a vessel to give the refrigerant a means to leave the compressor.

### ⚠ CAUTION

Always run the chiller cooler and condenser water pumps and always charge or transfer refrigerant as a gas when the chiller pressure is less than 35 psig (241 kPa). Below these pressures, liquid refrigerant flashes into gas, resulting in extremely low temperatures in the cooler/condenser tubes and possibly causing tube freeze-up.

### ⚠ DANGER

During transfer of refrigerant into and out of the optional storage tank, carefully monitor the storage tank level gage. Do not fill the tank more than 90% of capacity to allow for refrigerant expansion. Overfilling may result in damage to the tank or the release of refrigerant which will result in personal injury or death.

### ⚠ CAUTION

Do not mix refrigerants from chillers that use different compressor oils. Compressor damage can result. The pumpout oil separator comes pre-charged with 13 oz of ISO viscosity 220 POE (Polyol Ester) oil. The pumpout compressor is approved for use with ISO viscosity 220 POE oil or ISO viscosity 68 POE oil. The pumpout compressor is also factory precharged with oil.

**OPERATING THE OPTIONAL PUMPOUT UNIT** (Fig. 9) — Oil should be visible in the pumpout unit compressor sight glass under all operating conditions and during shutdown. If oil is low, add oil as described under Maintenance section, page 17. The pumpout unit control wiring schematic is detailed in Fig. 8.

To Read Refrigerant Pressures (during pumpout or leak testing):

1. The ICVC display on the chiller control panel is suitable for determining refrigerant-side pressures and low (soft) vacuum. To assure the desired range and accuracy when measuring evacuation and dehydration, use a quality vacuum indicator or manometer. This can be placed on the Schrader connections on each vessel by removing the pressure transducer.
2. To determine pumpout storage tank pressure, a 30 in. Hg vacuum -0-400 psi (-101-0-2769 kPa) gage is attached to the storage tank.
3. Refer to Fig. 10 and 11 for valve locations and numbers.

### ⚠ CAUTION

Transfer, addition, or removal of refrigerant in spring-isolated chillers may place severe stress on external piping if springs have not been blocked in both up and down directions.

Positive Pressure Chillers With Storage Tanks — In the Valve/Condition tables that accompany these instructions, the letter “C” indicates a closed valve. Figures 9 and 10 show the locations of the valves.

### ⚠ CAUTION

Always run chiller cooler and condenser water pumps and always charge or transfer refrigerant as a gas when chiller vessel pressure is less than 35 psig (241 kPa). Below these pressures, liquid refrigerant flashes into gas, resulting in extremely low temperatures in the cooler/condenser tubes and possibly causing tube freeze-up.

### ⚠ CAUTION

The power to the pumpout compressor oil heater must be on whenever any valve connecting the pumpout compressor to the chiller or storage tank is open. Leaving the heater off will result in oil dilution by refrigerant and can lead to compressor failure.

If the compressor is found with the heater off and a valve open the heater must be on for at least 4 hours to drive the refrigerant from the oil. When heating the oil the compressor suction must be open to a vessel to give the refrigerant a means to leave the compressor.

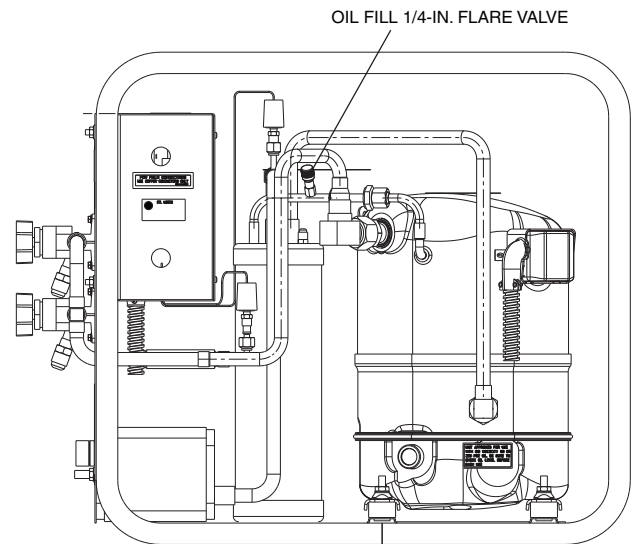
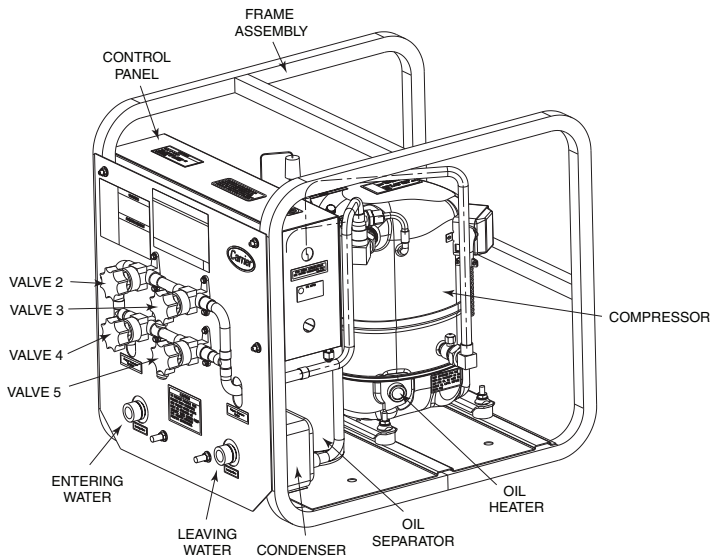

**Fig. 9 — Pumpout Unit**

*Transfer Refrigerant from Storage Tank Vessel to Chiller*

**⚠ WARNING**

During transfer of refrigerant into and out of the 19XR storage tank, carefully monitor the storage tank level gage. Do not fill the tank more than 90% of capacity to allow for refrigerant expansion. Overfilling may result in damage to the tank and personal injury.

1. Equalize refrigerant pressure.
  - a. Turn on chiller water pumps, establishing water flow (assumes vacuum condition in chiller system).
  - b. Close pumpout and storage tank valves 2, 4, 5, 7, 8, 10 (if present open isolation valve 11 and other isolation valves between cooler and condenser). Open storage tank valve 6; open chiller valves 1A and 1B.

VALVE	1A	1B	2	3	4	5	6	7	8	10	11
CONDITION			C		C	C		C	C	C	

- c. Gradually open valve 5 to slowly increase chiller pressure to 35 psig (241 kPa) to reduce the potential of tube freeze up.
- d. Open valve 5 fully after the chiller pressure reaches 35 psig (241 kPa) or greater. Let chiller pressure reach 40 psig (276 kPa), then chiller water pumps can be turned off. Fully close valve 5.

VALVE	1A	1B	2	3	4	5	6	7	8	10	11
CONDITION			C		C	C		C	C	C	

- e. Open valve 8 and 10 to let higher pressure in the recovery tank push liquid refrigerant into the condenser float chamber and heat exchangers until the refrigerant pressure equalizes between the recovery tank and chiller.

VALVE	1A	1B	2	3	4	5	6	7	8	10	11
CONDITION			C		C	C		C			

2. Push liquid to chiller, then remove remaining vapor from storage tank:
  - a. To prepare for liquid, push open valve 4.

VALVE	1A	1B	2	3	4	5	6	7	8	10	11
CONDITION				C		C		C			

- b. Ensure pumpout condenser water is off, then turn on the pumpout compressor in manual mode to push liquid to chiller. Monitor the storage tank level until tank is empty of liquid refrigerant.
- c. Close charging valves 8 and 10.
- d. Turn off the pumpout compressor.
- e. To prepare for removal of remaining refrigerant vapor in storage tank, close pumpout valves 3 and 4 and open valves 2 and 5.

VALVE	1A	1B	2	3	4	5	6	7	8	10	11
CONDITION				C	C			C	C	C	

- f. Turn on pumpout condenser water.
- g. Run pumpout unit in auto until the vacuum switch is satisfied. This occurs approximately at 15 in Hg vacuum (48 kPa absolute or 7 psia), removing the residual refrigerant vapor from the recovery tank and condensing to a liquid in the chiller.
- h. Close valves 1A, 1B, 2, 5, 6.

VALVE	1A	1B	2	3	4	5	6	7	8	10	11
CONDITION	C	C	C	C	C	C	C	C	C	C	

- i. Turn off pumpout condenser water.

*Transfer Refrigerant from Chiller to Storage Tank Vessel*

1. Equalize refrigerant pressure.
  - a. Dehydrate the refrigerant storage vessel, and connected hoses/piping so there are no non-condensables mixed with the refrigerant.
  - b. Locate valves as identified below:

VALVE	1A	1B	2	3	4	5	6	7	8	10	11
CONDITION			C		C	C		C	C	C	

- c. Slowly open valve 5 until the refrigerant pressure reaches 35 psig (241 kPa) in the storage

tank, followed by valves 7 and 10 to allow liquid refrigerant to drain by gravity.

VALVE	1A	1B	2	3	4	5	6	7	8	10	11
CONDITION			C		C				C		

2. Push remaining liquid, followed by refrigerant vapor removal from chiller.

- a. To prepare for liquid push, turn off the pumpout condenser water. Place valves in the following positions:

VALVE	1A	1B	2	3	4	5	6	7	8	10	11
CONDITION				C	C				C		

- b. Run the pumpout compressor in manual until all liquid is pushed out of the chiller (approximately 45 minutes). Close valves 2, 5, 7, and 10, then stop compressor.

VALVE	1A	1B	2	3	4	5	6	7	8	10	11
CONDITION			C	C	C	C		C	C	C	

- c. Turn on pumpout condenser water.  
d. Open valves 3 and 4, and place valves in the following positions:

VALVE	1A	1B	2	3	4	5	6	7	8	10	11
CONDITION			C			C		C	C	C	

- e. Run the pumpout compressor until the chiller pressure reaches 35 psig (241 kPa), followed by turning off the pumpout compressor. Warm chiller condenser water will boil off any entrapped liquid refrigerant, and chiller pressure will rise.  
f. When chiller pressure rises to 40 psig (276 kPa), turn on the pumpout compressor until the pressure reaches 35 psig (241 kPa) again; then turn off the pumpout compressor. Repeat this process until the chiller pressure no longer rises.  
g. Start the chiller water pumps (condenser and cooler), establishing water flow. At this point, turn on the pumpout compressor in auto until the vacuum switch is satisfied. This occurs at approximately 15 in Hg vacuum (48 kPa absolute or 7 psia).  
h. Close valves.

VALVE	1A	1B	2	3	4	5	6	7	8	10	11
CONDITION	C	C	C	C	C	C	C	C	C	C	

- i. Turn off the pumpout condenser water.

**Chillers With Isolation Valves** — In the Valve/Condition tables that accompany these instructions, the letter “C” indicates a closed valve.

The valves referred to in the following instructions are shown in Fig. 9 and 11. The cooler/condenser vessels can be used for refrigerant isolation for certain service conditions when the isolation valve package is specified.

*Transfer Refrigerant from Cooler to Condenser*

- a. Turn off chiller water pumps and pumpout condenser water supply (if applicable). It is assumed that the starting point is as shown in the following table and that pressures in both vessels are above 35 psig (241 kPa).

VALVE	1A	1B	2	3	4	5	7	8	11
CONDITION	C	C	C	C	C	C	C	C	C

- b. Keeping valves 7 and 8 closed, install charging hose from liquid line charging valve 7 to valve 8

on the condenser float chamber. Evacuate or purge hose of non-condensables. Note that this creates a flow path between cooler and condenser that bypasses the linear float, reducing the potential for damage during refrigerant transfer.

- c. Open valves 1A, 1B, 2, 5, and 8.

VALVE	1A	1B	2	3	4	5	7	8	11
CONDITION				C	C		C		C

- d. Turn on pumpout compressor, generating a refrigerant pressure differential of 10 to 20 psi (69 to 138 kPa) to push liquid out of the chiller cooler vessel.  
e. Slowly open valve 7 to allow liquid transfer. Rapid opening of valve 7 can result in float valve damage.  
f. When all liquid has been pushed into the chiller condenser vessel, close valve 8.

VALVE	1A	1B	2	3	4	5	7	8	11
CONDITION				C	C			C	C

- g. Turn off the pumpout compressor.  
h. Close pumpout valves 2 and 5 while opening valve 3 and 4 to prepare for removal of remaining refrigerant vapor in cooler vessel.

VALVE	1A	1B	2	3	4	5	7	8	11
CONDITION			C			C		C	C

- i. Turn on pumpout condenser water.  
j. Turn on pumpout compressor. Turn on the chiller water pump to establish water flow when the cooler refrigerant pressure is 35 psig (241 kPa). **The water pumps have to be in operation whenever the refrigerant pressure is equal to or less than 35 psig (241 kPa) to reduce the potential of tube damage.**  
k. Run the pumpout compressor until the cooler pressure reaches 35 psig (241 kPa), then turn off the pumpout compressor. Warm chiller cooler water will boil off any entrapped liquid refrigerant, and chiller pressure will rise. Repeat this process until the chiller pressure no longer rises.  
l. Run pumpout unit in auto until the vacuum switch is satisfied; this occurs at approximately 15 in. Hg vacuum (48 kPa absolute or 7 psia). Close valve 1A.

VALVE	1A	1B	2	3	4	5	7	8	11
CONDITION	C		C			C		C	C

- m. Monitor that cooler pressure does not rise (if it does, then repeat previous step).  
n. With service valve 1A closed, shut down pumpout compressor (if still running).  
o. Close remaining valves.

VALVE	1A	1B	2	3	4	5	7	8	11
CONDITION	C	C	C	C	C	C	C	C	C

- p. Remove charging hose between 7 and 8 (evacuate prior to removal).  
q. Turn off pumpout condenser water.  
r. Turn off chiller water pumps, and lockout chiller compressor.

*Transfer Refrigerant from Condenser to Cooler*

- a. Turn off chiller water pumps and pumpout condenser water supply (if applicable). It is assumed that the starting point is as shown in the following

table and that pressures in both vessels are above 35 psig (241 kPa).

VALVE	1A	1B	2	3	4	5	7	8	11
CONDITION	C	C	C	C	C	C	C	C	C

b. Set valves as shown below to allow the refrigerant to equalize:

VALVE	1A	1B	2	3	4	5	7	8	11
CONDITION			C			C	C	C	C

- Turn on pumpout compressor, and develop a 10 to 20 psi (69 to 138 kPa) refrigerant differential pressure between the vessels.
- Partially open valve 11 while maintaining a refrigerant pressure differential to push liquid refrigerant out of the chiller condenser to the cooler.
- When all liquid is out of the chiller condenser, close valve 11 and any other isolation valves on the chiller.
- Turn off the pumpout compressor.
- Close pumpout valves 3 and 4 while opening valve 2 and 5 to prepare for removal of remaining refrigerant vapor in condenser vessel.

VALVE	1A	1B	2	3	4	5	7	8	11
CONDITION				C	C		C	C	C

- Turn on pumpout condenser water.
- Turn on pumpout compressor.
- Turn on the chiller water pumps, establishing water flow when the condenser refrigerant pressure is 35 psig (241 kPa). **The water pumps have to be in operation whenever the refrigerant pressure is equal to or less than 35 psig (241 kPa) to reduce the potential of tube damage.**
- Run the pumpout compressor until the condenser refrigerant pressure reaches 35 psig (241 kPa) then turn off the pumpout compressor. Warm condenser water will boil off any entrapped liquid refrigerant, and chiller pressure will rise. Repeat this process until the chiller pressure no longer rises.
- Run pumpout unit in auto until the vacuum switch is satisfied; this occurs at approximately 15 in. Hg vacuum (48 kPa absolute or 7 psia). Close valve 1B.

VALVE	1A	1B	2	3	4	5	7	8	11
CONDITION		C		C	C		C	C	C

- Monitor that condenser pressure does not rise (if it does, then repeat previous step).
- With service valve 1B closed, shut down pumpout compressor (if still running).
- Close remaining valves.

VALVE	1A	1B	2	3	4	5	7	8	11
CONDITION	C	C	C	C	C	C	C	C	C

- Turn off pumpout condenser water.
- Turn off chiller water pumps, and lock out chiller compressor.

#### Return Chiller to Normal Operating Conditions

- Vapor Pressure Equalization:
  - Ensure that the chiller vessel that was exposed to ambient has been evacuated. Final vacuum prior to charging with refrigerant should in all cases be 29.9 in. Hg (500 microns, 0.07 kPa [abs]) or less.
  - Turn on chiller water pumps.

c. Open valves 1A, 1B, and 2.

VALVE	1A	1B	2	3	4	5	7	8	11
CONDITION				C	C	C	C	C	C

- Slowly open valve 4, gradually increasing pressure in the evacuated vessel to 35 psig (241 kPa).
- Leak test to ensure chiller vessel integrity.
- Open valve 4 fully for cooler and condenser pressure equalization (vapor equalization).

VALVE	1A	1B	2	3	4	5	7	8	11
CONDITION				C		C	C	C	C

g. Close valves 1A, 1B, 2, and 4.

VALVE	1A	1B	2	3	4	5	7	8	11
CONDITION	C	C	C	C	C	C	C	C	C

#### 2. Liquid equalization:

- If refrigerant is stored in cooler, install a charging hose between valves 7 and 8, and open both the valves and any other isolation valves (except valve 11) for liquid to drain into the condenser while bypassing the linear float valve. If refrigerant is stored in the condenser, keep valve 11 and any other isolation valves open for liquid drain.

VALVE	1A	1B	2	3	4	5	7	8	11
CONDITION (CHARGE IN COOLER)	C	C	C	C	C	C			C
CONDITION (CHARGE IN CONDENSER)	C	C	C	C	C	C	C	C	

- If valves 7 and 8 were used to bypass the linear float valve, once the liquid transfer is complete, close these valves, and slowly open valve 11.
- Turn off chiller water pumps.

#### Distilling the Refrigerant

- Transfer the refrigerant from the chiller to the pumpout storage tank as described in the Transfer Refrigerant from Chiller to Storage Tank Vessel section.
- Equalize the refrigerant pressure.
  - Turn on chiller water pumps and monitor chiller pressures.
  - Close pumpout and storage tank valves 2, 4, 5, and 10, and close chiller charging valve 7; open chiller isolation valve 11 and any other chiller isolation valves, if present.
  - Open pumpout and storage tank valves 3 and 6; open chiller valves 1a and 1b.

VALVE	1A	1B	2	3	4	5	6	7	10	11
CONDITION			C		C	C		C	C	

- Gradually crack open valve 5 to increase chiller pressure to 35 psig (241 kPa). Slowly feed refrigerant to prevent freeze-up.
- Open valve 5 fully after the chiller pressure rises above the freezing point of the refrigerant. Let the storage tank and chiller pressure equalize.

#### 3. Transfer remaining refrigerant.

- Close valve 3.
- Open valve 2.

VALVE	1A	1B	2	3	4	5	6	7	10	11
CONDITION				C	C			C	C	

- Turn on pumpout condenser water.

- d. Run the pumpout compressor until the storage tank pressure reaches 5 psig (34 kPa), 18 in. Hg vacuum (41 kPa absolute) in Manual or Automatic mode.
- e. Turn off the pumpout compressor.

- f. Close valves 1a, 1b, 2, 5, and 6. Turn off pumpout condenser water.

VALVE	1A	1B	2	3	4	5	6	7	10	11
CONDITION	C	C	C	C	C	C	C	C	C	C

- 4. Drain the contaminants from the bottom of the storage tank into a container. Dispose of contaminants safely.

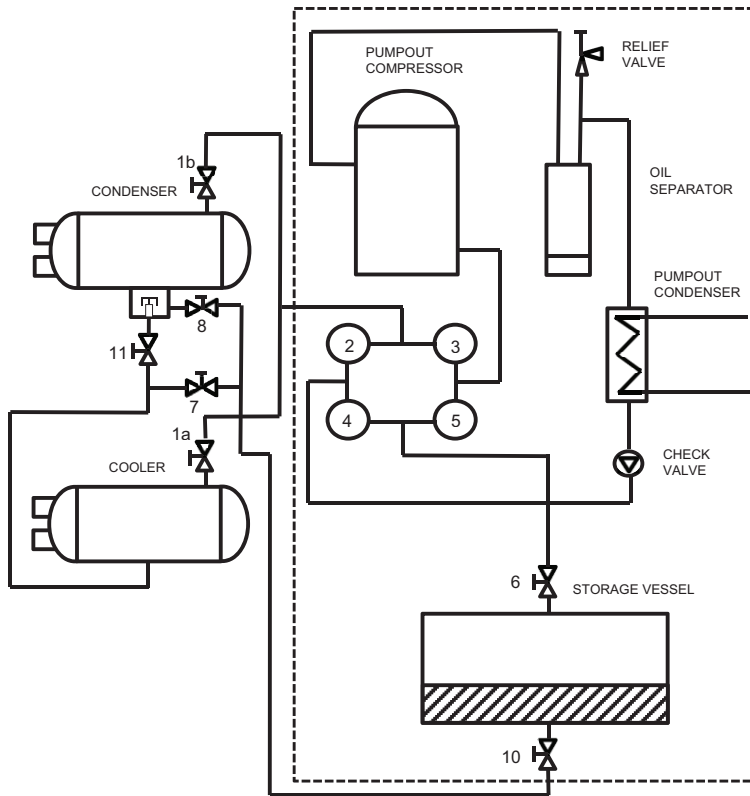

NOTES:

- 1. Maintain at least 2 feet (610 mm) clearance around storage tank for service and operation work.
- 2. Valve 8 is only applicable for products with linear float valves.

**Fig. 10 — Typical Optional Pumpout System Piping Schematic with Storage Tank**



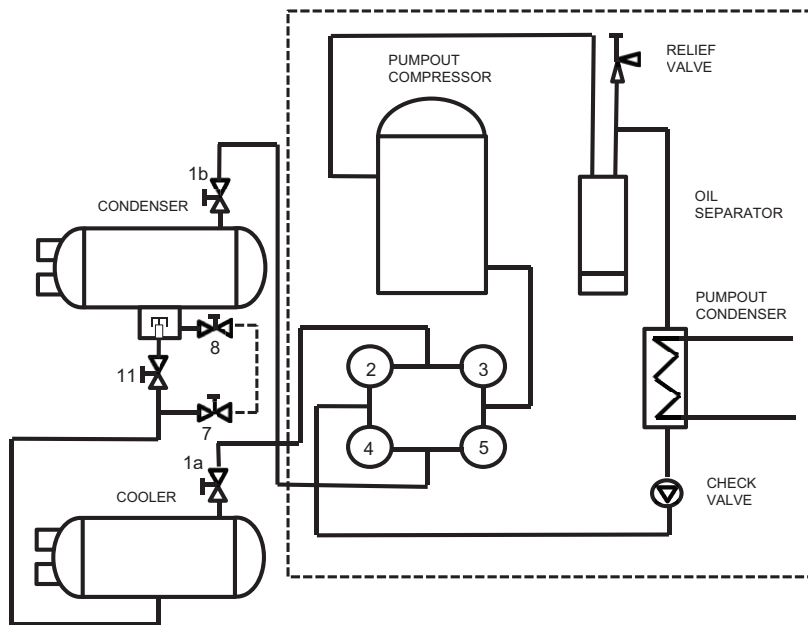

NOTE: Valve 8 is only applicable for products with linear float valves.

**Fig. 11 — Typical Optional Pumpout System Piping Schematic without Storage Tank**

## MAINTENANCE

Periodic maintenance is necessary to keep all components functioning as designed. A maintenance log is recommended to ensure a proper maintenance schedule is followed.

**Pumpout Compressor Oil Charge** — Use oil conforming to Carrier specifications for centrifugal or screw compressor use. Oil requirements are listed in Table 6.

Monitor and adjust compressor oil level as often as necessary. When replacing lost oil, add the same type of oil that is used in the chiller being pumped out.

**Table 6 — Pumpout Compressor Requirements**

REFRIGERANT	ISO VISCOSITY	CARRIER SPECIFICATION NO.
R-134a	68	PP47-31
	220	PP47-32

The pumpout oil separator comes pre-charged with 13 oz of ISO viscosity 220 POE (Polyol Ester) oil. The pumpout compressor is approved for use with ISO viscosity 220 POE oil or ISO viscosity 68 POE oil. The pumpout compressor is also factory precharged with POE oil.

Oil should be visible in the pumpout compressor sight glass both during operation and at shutdown. Always check the oil level before operating the pumpout compressor.

Oil can be added to the 1/4-in. SAE flare access valve port running from the top of the oil separator to the compressor while the compressor is running. Be careful not to overfill.

NOTE: Compressor access valve has a self-sealing fitting which will require a hose connection with a depressor to open.

To change or remove oil, the compressor will have to be removed from the assembly. Compressor can be disconnected from connected tubing by the quick connect fittings at suction and discharge and oil recovery line.

Prior to removal, close service valves 2, 3, 4, and 5, and run the pumpout compressor in AUTOMATIC until the vacuum switch is satisfied and the compressor shuts off.

Move pumpout selector switch to OFF, and turn off all power to unit prior to removing compressor unit from pumpout assembly frame and connecting tubing.

Service valves 2, 3, 4, and 5 remain closed while compressor is removed. Put compressor back in place. Use the torque values listed in Table 7 for reassembly:

**Table 7 — Torque Values for Reassembly**

PARAMETER	VALUES	
	ft-lb	Nm
Suction	80 to 100	109 to 136
Discharge	50 to 60	68 to 81
O-ring Face Seal	7 to 9	10 to 12

Be sure to use backup wrench and pull a deep vacuum in the serviced pumpout tubing prior to any refrigerant exposure. At this point, confirm that the oil level is satisfactory and put the pumpout back in service.

**Storage Tank** — To prevent moisture and contaminants from entering the storage tank, maintain positive pressure in the tank when not transferring refrigerant. Leak test the storage tank periodically.

**Ordering Replacement Parts** — The following information must accompany an order for Carrier-specified parts:

- machine model number and serial number
- name, quantity, and part number of the part required
- delivery address and method of shipment

## TROUBLESHOOTING

Information on troubleshooting for the PPS system is included in Table 8.

**Table 8 — Troubleshooting**

<b>SYMPTOM</b>	<b>PROBABLE CAUSE</b>	<b>REMEDY</b>
<b>Compressor Does Not Run</b>	Main power line open	Replace fuse or reset circuit breaker.
	Loose terminal connection	Check connections.
	Improperly wired controls	Check wiring and rewire.
	Low line voltage	Check line voltage; determine location of voltage drop.
	Compressor motor defective	Check motor winding for open or short. Replace compressor if necessary.
	Seized compressor	Replace compressor.
<b>Compressor Cycles On High-Pressure Control</b>	High level gage alarm	Check refrigerant level and remove excess.
	High-pressure control erratic in action	Check capillary tube for pinches. Set control as required.
	Discharge valve partially closed.	Open valve.
	Air in system	Purge system.
	Condenser scaled.	Clean condenser.
<b>Unit Operates Too Long</b>	Condenser water pump or fans not operating.	Start pump or fans.
	Isolation valves partially open	Close valves.
<b>System Noises</b>	Piping vibrations	Support piping as required. Check for loose pipe connectors.
	Insufficient compressor oil	Add oil.
<b>Compressor Loses Oil</b>	Leak in system	Locate and repair leak.
	Plugged or stuck compressor oil return check valve	Repair or replace valve.
	Liquid refrigerant carries oil out of compressor	Check to ensure only refrigerant vapor enters compressor suction line. Add oil as necessary.
	Motor shutdown on internal thermal protection high temperature cutout.	High temperature cutout should reset within 120 minutes.



