



Geothermal and
Hydronics Specialists

Installation, Operating, and Maintenance Manual



Part # 2122
Rev. 07FEB2014

Flo-Link™ and GPM Series Pressurized Flow Centers

Table of Contents

General Description	1
Flow Center Sizing	2
Installation	6
Flushing and Purging	8
Adding Antifreeze.16
Water Quality21
Start-up24
Maintenance.26
Troubleshooting31

NOTES:

This guide provides the installer with instructions specific to pressurized Flow Centers. Please refer to your heat pump manufacturer’s instructions or IGSHPA guidelines for additional detailed flushing, purging, and installation information. Please review the entire IOM document before proceeding with the installation.

Geo-Flo Products Corporation is continually working to improve its products. As a result, the design and specifications of products in this document may change without notice and may not be as described herein. For the most up-to-date information, please visit our website, or contact our customer service department. Statements and other information contained in this document are not express warranties and do not form the basis of any bargain between the parties, but are merely Geo-Flo’s opinion or commendation of its products.

General Description

Geo-Flo offers two types of pressurized flow centers, Flo-Link™ series and GPM series. The Flo-Link series flow centers simplify installation using Flo-Link double O-Ring fittings that eliminate the possibility of leaks that sometimes occur with threaded fittings. Front flush ports allow easy access during installation. Foam insulation stops condensation, and the high impact polystyrene cabinet will not rust. Flo-Link flow centers are available with either die cast brass or composite valves. Flo-Link flow centers offer both constant speed and variable speed pump options.

The GPM series flow centers utilize reliable 3-way valves with the same features and benefits as the Flo-Link valves, but have threaded FPT connections. GPM flow centers are available in one to four pump configurations, and may be ordered with or without the foamed cabinet. In addition, GPM flow centers are available with isolation valves for applications where the flushing valves are located underground or remotely.

All Geo-Flo flow centers are fully assembled and leak tested. Geo-Flo utilizes industry standard Grundfos circulators (one to four pumps). The cabinets are designed to allow pump heads to be rotated, or for upgrading/downgrading (i.e. adding/removing a pump).

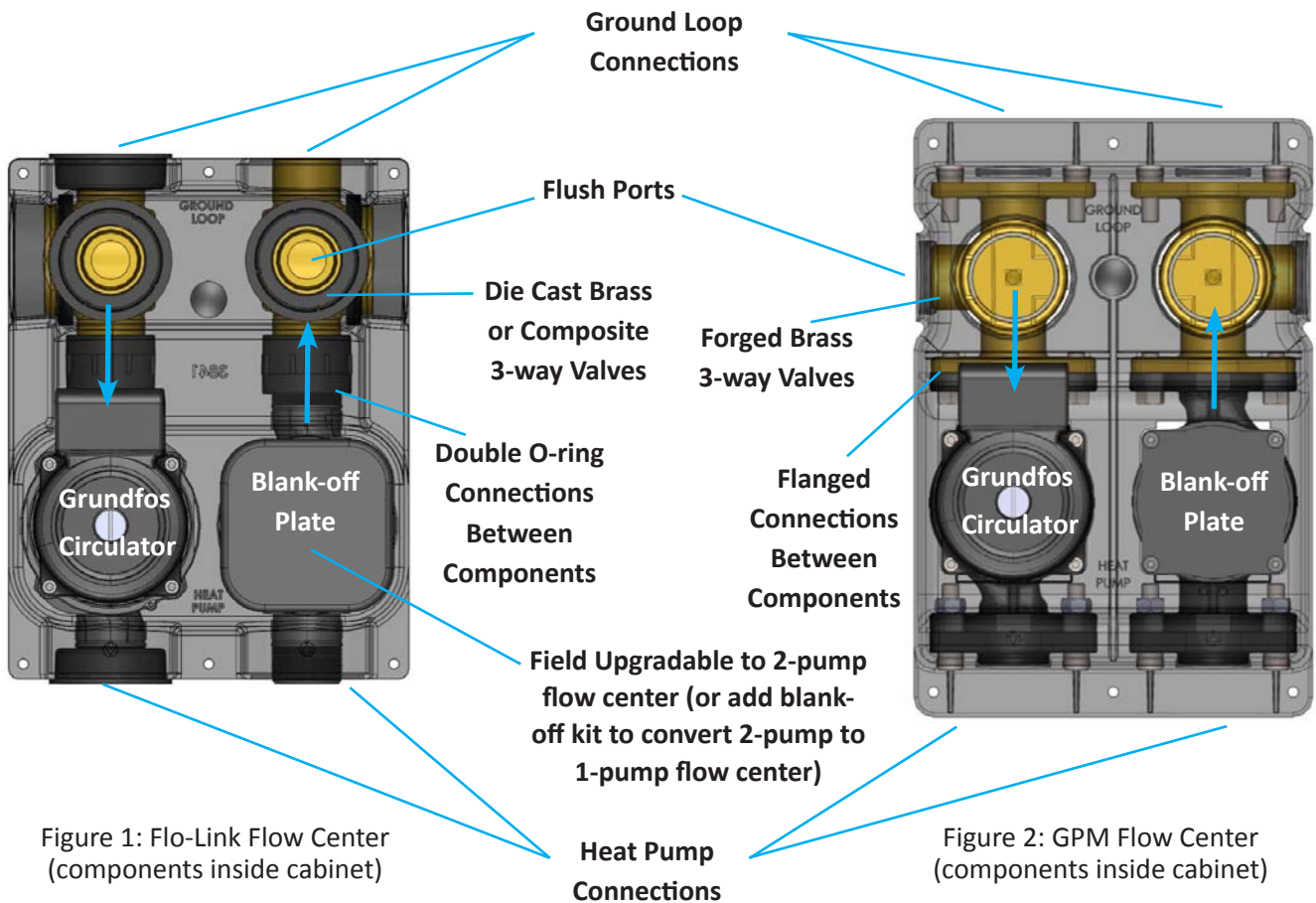

NOTE: Geo-Flo manufactures flow centers for some heat pump manufacturers that have the flow rate in the opposite direction of the arrows shown above. Verify direction of flow before connecting to heat pump (see arrows molded or stamped into the cabinet).

Flow Center Sizing

Design Notes

Pressurized flow centers with more than one pump are assembled so that when installed, the pumps are in series. This can be thought of as a “push-pull” pumping arrangement. Figures 1 and 2 show transparent views of Flo-Link (FL) and GPM flow centers.

When sizing pumps, a pressure drop calculation should be done for the entire system. Verify with online Calculators at www.geo-flo.com, or to manually select pumps, use the curves below.

Performance Curves - FL1 and GPM-1

Flo-Link FL1 and GPM-1 flow centers use one UPS26-99 (3-speed) or one UP26-116 (single speed) on the left side of the flow center. The curves below illustrate performance. Older FL1 and GPM-1 flow centers used the UP26-99 (single speed pump), which is shown as well. Use the curves to determine pump selection that meets design requirements.

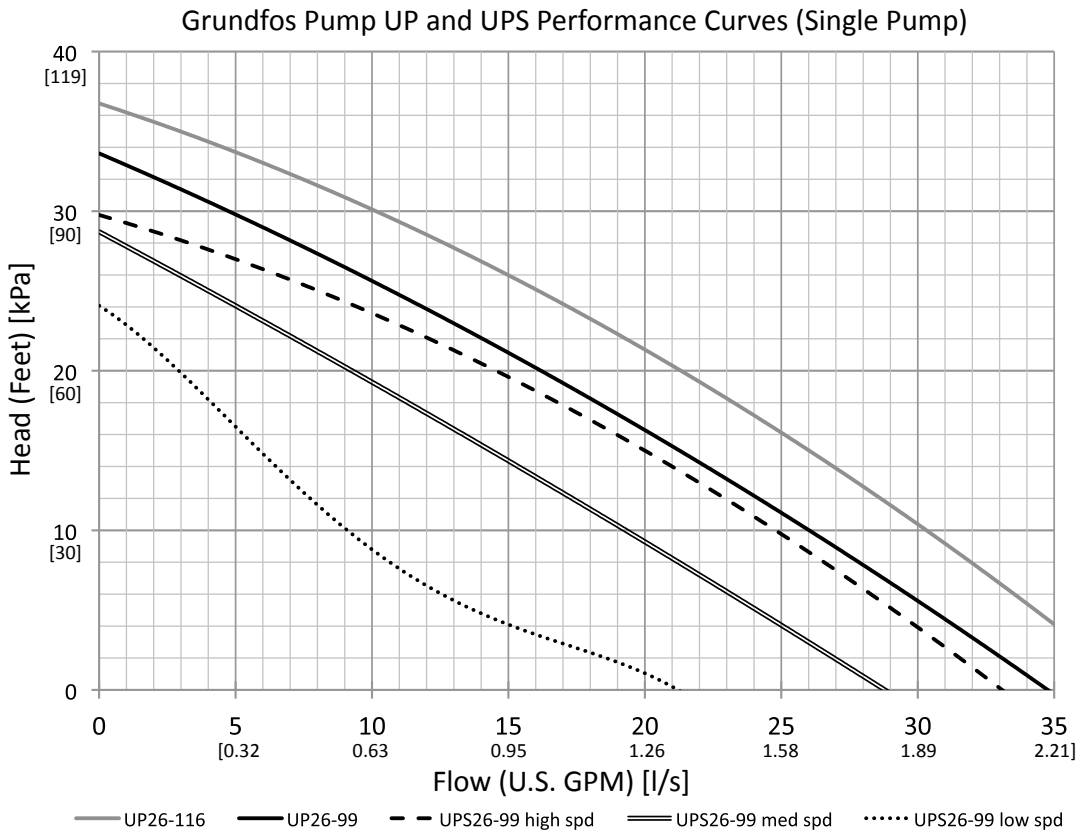

All pump curves are manufacturer’s reported averages using water at 68°F [20°C]

Performance Curves - FLV1

Variable speed pumping is available for Flo-Link (FL) series flow centers. One (FLV1) or two (FLV2) pumps are available. The Grundfos Magna GEO variable speed pump can operate anywhere between the minimum and maximum curves, adjusting based upon flow rate setting or temperature difference. For example, a 4 ton two-stage geothermal heat pump might operate at 173 Watts on full load and 12 GPM, but on part load at 9 GPM and 77 Watts, saving more than 100 Watts versus a constant speed circulator 80% of time. Geo-Flo has an online Pump Sizing Calculator at www.geo-flo.com that provides operating cost comparisons.

It is even more important to calculate system pressure drop for variable speed systems. Since the Magna GEO has better performance than a typical constant speed pump, it can sometimes take the place of two UPS26-99 pumps, depending upon the ground loop configuration.

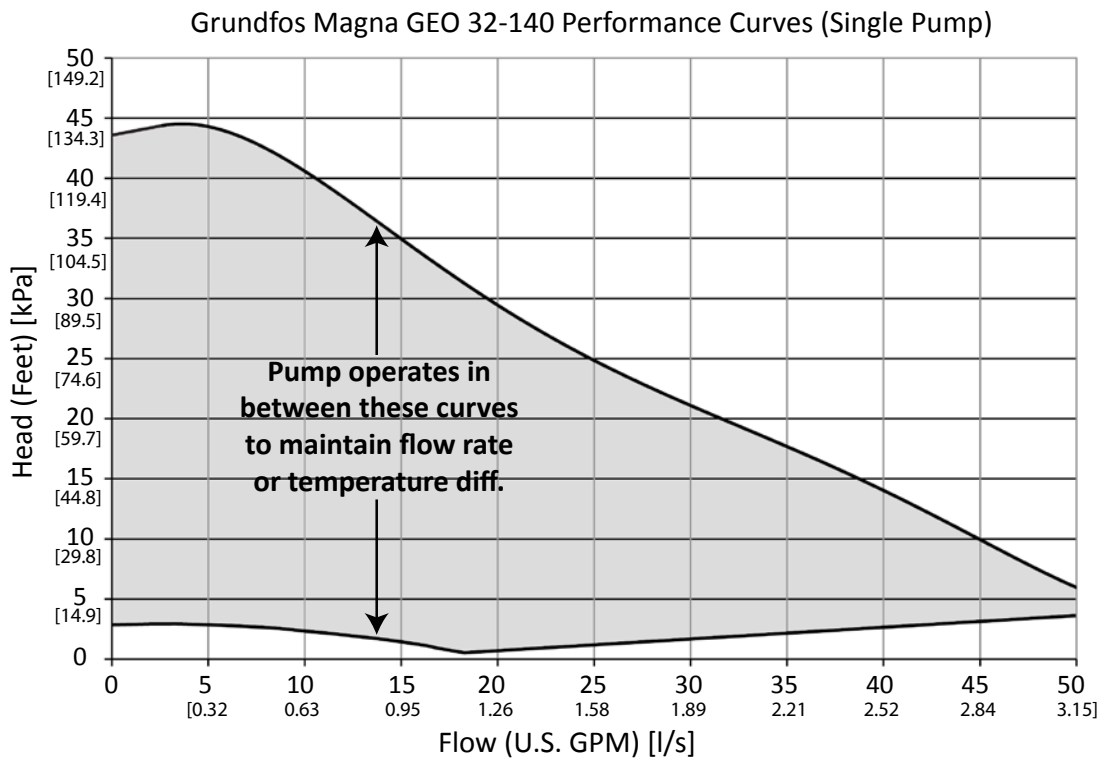

All pump curves are manufacturer’s reported averages using water at 68°F [20°C]

Performance Curves - FL2 and GPM-2

Flo-Link FL2 and GPM-2 flow centers use two UPS26-99 (3-speed) or two UP26-116 (single speed) pumps, one on each side of the flow center. One pump pushes, and one pump pulls, effectively placing the two pumps in series. The curves below illustrate performance. Older FL1 and GPM-1 flow centers used the UP26-99 (single speed pump), which is shown as well. Use the curves to determine pump selection that meets design requirements.

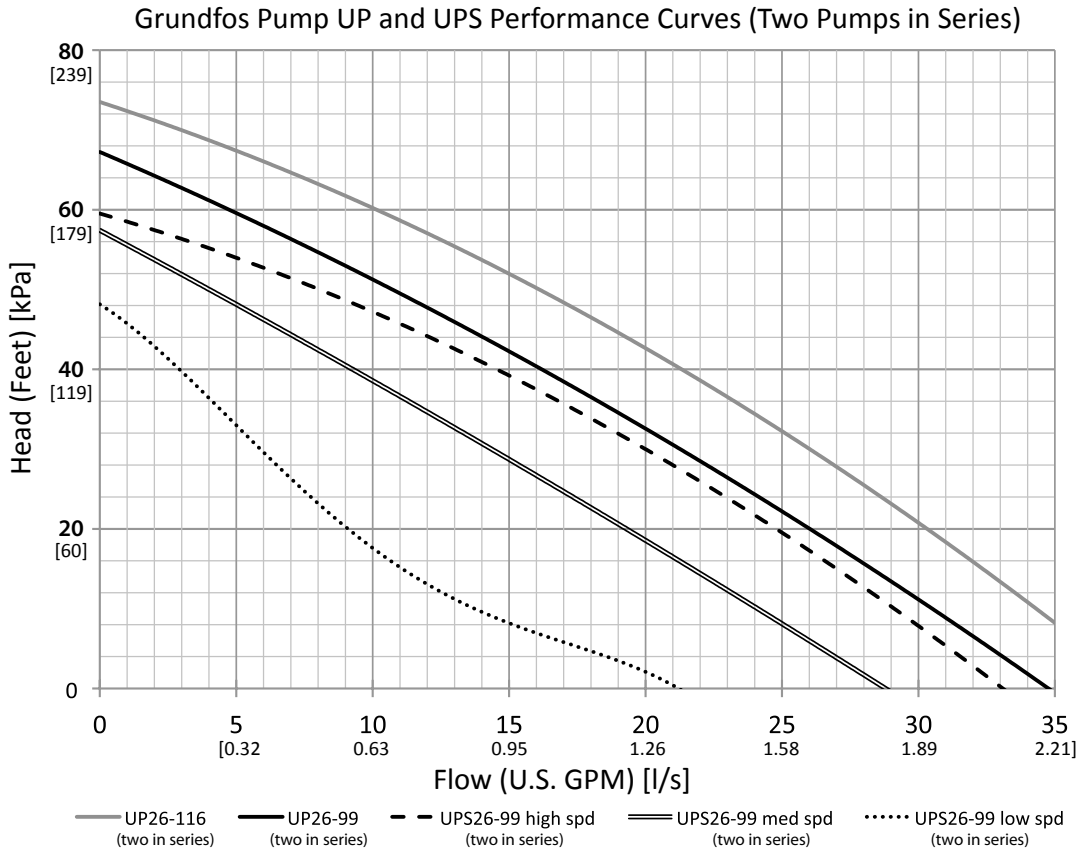

All pump curves are manufacturer’s reported averages using water at 68°F [20°C]

Performance Curves - FLV2

Variable speed pumping is available for Flo-Link (FL) series flow centers. The two pump variable speed flow center uses one Grundfos Magna GEO variable speed pump and one UPS26-99 3-speed pump. Like the one-pump flow center (FLV1), the combination can operate anywhere between the minimum and maximum curves, adjusting based upon flow rate setting or temperature difference. When used with a Grundfos UPC-GEO controller, the controller will try to satisfy the requirement with the variable speed pump to maximize operating cost savings. If the set point cannot be reached with the variable speed pump, the constant speed (UPS26-99) pump is energized, and the variable speed pump slows down to adjust set point. This control algorithm achieves two-pump variable speed operation with a much lower cost than using two variable speed pumps.

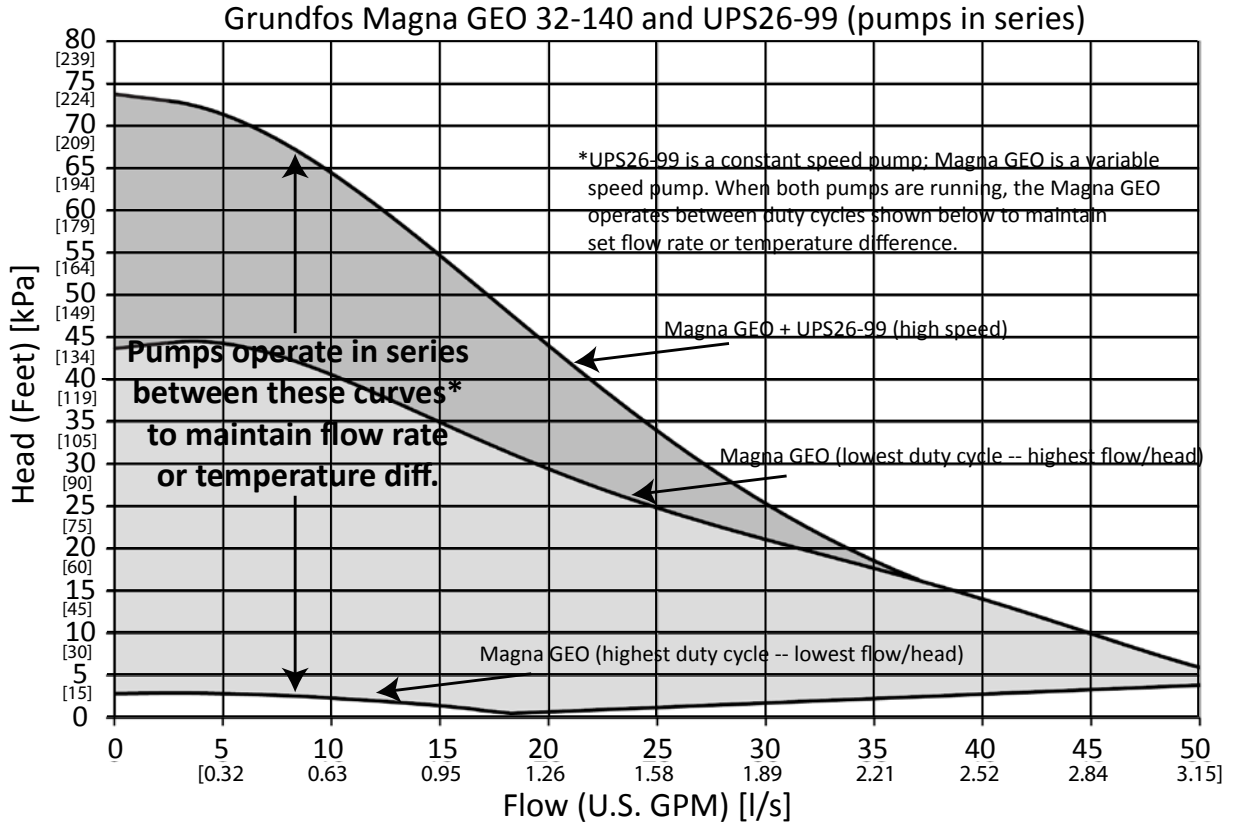

All pump curves are manufacturer’s reported averages using water at 68°F [20°C]

Performance Curves - GPM-3 and GPM-4

Like the GPM-2, the pumps are in series for GPM-3 and GPM-4 flow centers. Figure 3 shows a GPM-3. The GPM-4 has one more pump on the lower right hand side. The pumps on the right push, and the pump(s) on the left pull. For performance curves, use the FL1 and GPM-1 curves, and multiply the head by the number of pumps. For example, a GPM-3 flow center with all three UPS26-99 pumps on high speed could produce 14.5 GPM at 60 ft. of head (60 = 3 x 20). Likewise, a GPM-4 with UP26-116 pumps could produce 15 GPM at 104 ft. of head (104 = 4 x 26). Geo-Flo has an online Pump Sizing Calculator at www.geo-flo.com to assist with selecting pump combinations.



Figure 3: GPM-3 Flow Center

Installation

Mounting the Unit

Flo-Link and GPM Series flow centers are designed for indoor installation only, and should be mounted near the ground source heat pump. The unit should be secured using the supplied hardware.

The flow center can be mounted with the flow paths either vertical or horizontal (see Figure 4). However, the flow center cannot be mounted on its back, upside down, or at an angle, as premature pump failure will occur when the pump shaft is not in the horizontal position.

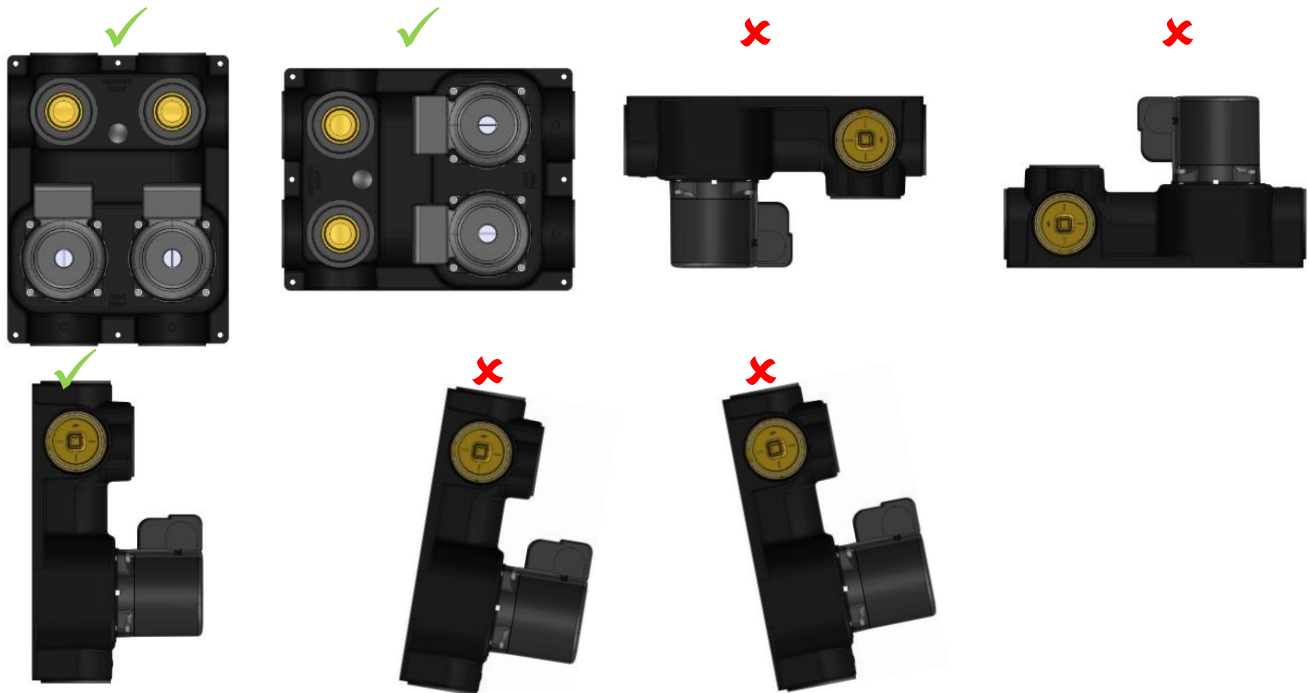

Figure 4: Acceptable mounting positions for Flo-Link and GPM series flow centers

Equally important to pump longevity is terminal box orientation. See Figure 5, 6, and 7 for proper control box orientation. The pump terminal box must be located in a position to avoid condensation running into the control box, and also to take advantage of the “weep holes” designed to drain any condensation that may have formed (Figure 6). “Weep holes” are located on three sides of the pump.

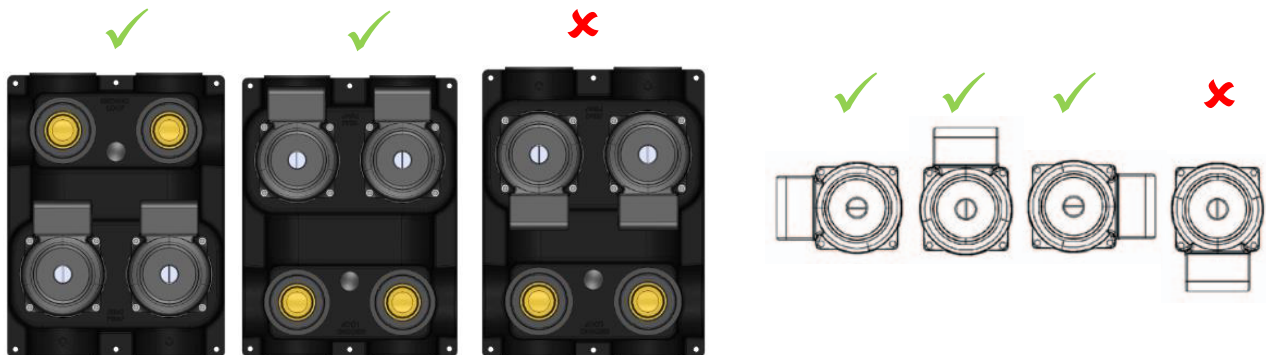

Figure 5: Acceptable terminal box locations for UPS26-99, UP26-99, and UP26-116 pumps.



Figure 6: Example “Weep Hole”

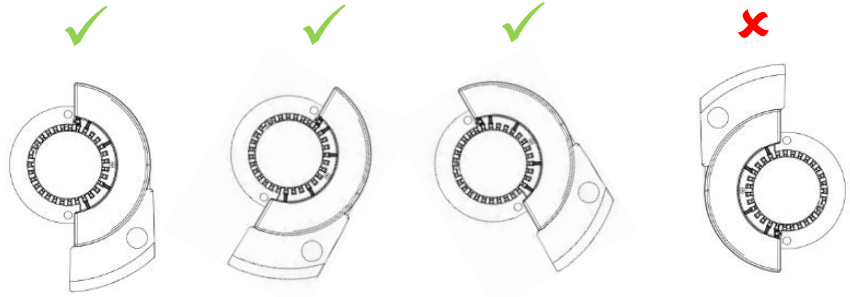

Figure 7: Correct terminal box location for Grundfos Magna GEO variable speed pump

Plumbing Options

The Flo-Link flow center can be plumbed with a wide variety of materials including HDPE, copper, PEX, and flexible hose to provide many options to the installer. Figure 8 show examples of Flo-Link double O-ring adapters and a hose kit specifically designed for this type of flow center. The piping should be properly supported to prevent excessive stress on the three-way valves.

GPM series use 1” FPT connections for the ground loop and heat pump connections. Geo-Flo offers a wide variety of threaded adapters for HDPE fusion, hose barb, and other connection types. A hose kit is also available for GPM flow centers. The piping should be properly supported to prevent excessive stress on the three-way valves.



Figure 8: Example Flo-Link Double O-ring adapter sets

Flushing and Purging

Before beginning this procedure carefully study the flush cart diagram in Figure 11 to become familiar with the valves used throughout the process. Actual flushing time will vary depending on the size and configuration of the loop. However, typically flushing will require *at least* 2 hours of continues pump operation.

1. Position flush cart near the flow center. If flow center or purge valves are located in an area difficult to access (such as a crawl space), two extension hoses 20' long can be connected to the standard hoses to provide additional reach.
2. Attach 1-1/2" hoses to 1-1/2" cam fittings on flush cart.
3. Attach flow center cam adapter fittings to flush cart hoses. If using a FPT flow center, attach 1" MPT X 1" cam fittings, or 1" MPT X Flo-Link female fittings to the flow center first (Figure 9). Then attach flush cart hoses. The 1" MPT X Flo-Link female along with the 1" cam X Flo-Link elbows allow the flush hoses to hang vertically and provide a rotating union connection.
4. Attach garden/utility hose to 1/2" fill valve (Figure 10). Attach other end of hose to acceptable municipal water supply or pre-mixed antifreeze source and transfer pump.



WARNING: ONLY USE PREMIXED ANTIFREEZE IN A NON-FLAMMABLE STATE. FAILURE TO OBSERVE SAFETY PRECAUTIONS MAY RESULT IN FIRE, INJURY, OR DEATH.

5. Rotate 3-way valves on flow center so that the heat pump circuit is isolated and fluid is directed toward the ground loop only. Figure 12 shows examples of how the valves may be oriented. This will vary depending on the type of flow center installed.

NOTE: Due to the nature of the installation process, the ground loop typically has a higher amount of debris than the heat pump circuit. Therefore, flushing the ground loop piping prior to flushing the heat pump and associated piping is recommended. This should prevent accidentally pushing debris through the heat pump's heat exchanger and/or the circulator pumps.

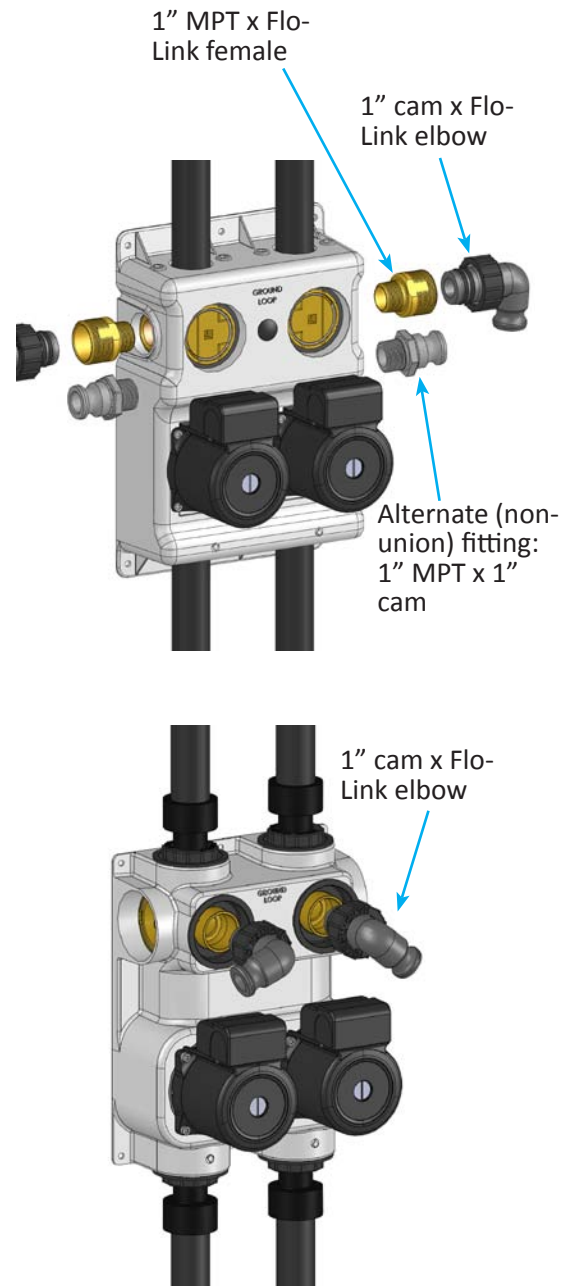

Figure 9: FPT flow center (top) and Flo-Link Double O-ring flow center (below) flush cart fittings



Figure 10: Fill Valve/Tank Isolation Valve

Flush Cart Diagram



Figure 11: Flush cart diagram with descriptions

Each flush cart includes two flush hoses; the style depends on the flush cart purchased. Twenty foot hose extensions are also available.

6. Insert pressure gauge with large dial face with a P/T adapter into P/T port on flush cart. Close 1/2" pump & dump valve (Figure 13).
7. Ensure that the bag filter is in place on the return PVC pipe. Geo-Flo recommends looping the filter bag strap over the top of the return piping.
8. Close 2" tank isolation valve (Figure 10) and open the 1-1/2" dead-head valve (Figure 14).
9. Open 1/2" fill valve (Figure 10) and allow the loop to fill. Watch the fluid level in the tank via the sight tube. When the tank is nearly full, shut off the 1/2" fill valve and 1-1/2" supply valve (Figure 14).
10. Open the 2" tank isolation valve (Figure 10) and energize the pump. Slowly open the 1-1/2" supply valve (Figure 14) approximately 1/4 to 1/2 open. Air and debris will be pushed through the return piping. Debris will be captured in the bag filter and air will be released to the atmosphere.
11. Regulate the fluid level in the tank with the 1/2" fill valve (Figure 10) and the 1-1/2" supply valve (Figure 14) while the pump is running. Do not allow the fluid in the tank to drop too low or air will be pushed back into the loop extending flushing time.

NOTE: The 100 micron bag filter must be in place during flushing to filter debris from the loop. Debris is a leading cause of circulator pump failure.

NOTE: When the pump is running any air remaining in the loop will be pressurized. Therefore, if the pump is powered off during the flushing process the compressed air will expand pushing the loop fluid back in the tank. This could cause the tank to overflow. If the pump must be shut off during the process, close the 1-1/2" supply valve (Figure 14) and the 1-1/2" dead-head/return valve (Figure 14) to prevent fluid from returning to the tank.

12. When the fluid level remains relatively stable ensure that the 1-1/2" supply valve (Figure 14) is fully open.

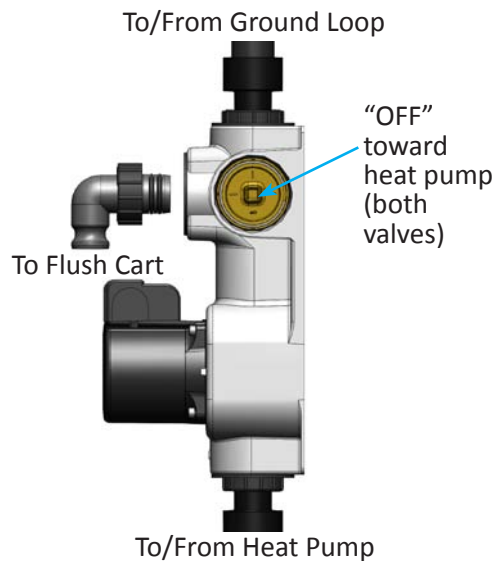
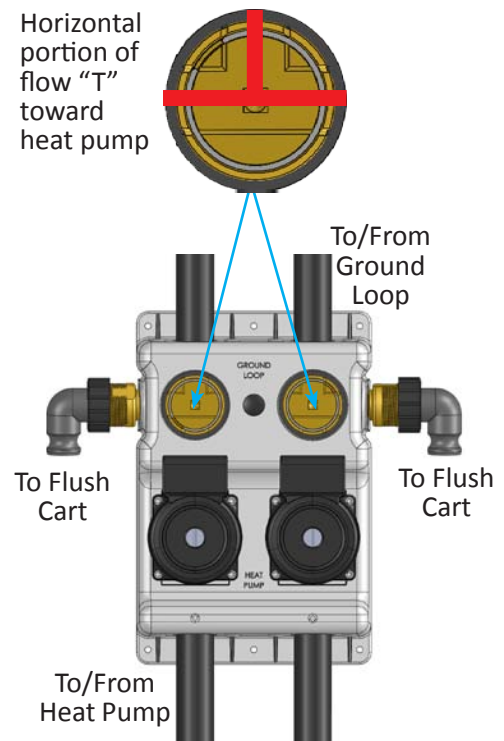

Figure 12: FPT flow center (top) and Flo-Link Double O-ring flow center (below) valve positions for heat pump isolation

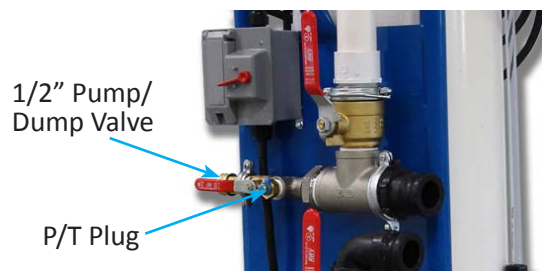

Figure 13: 1/2" Pump & Dump Valve

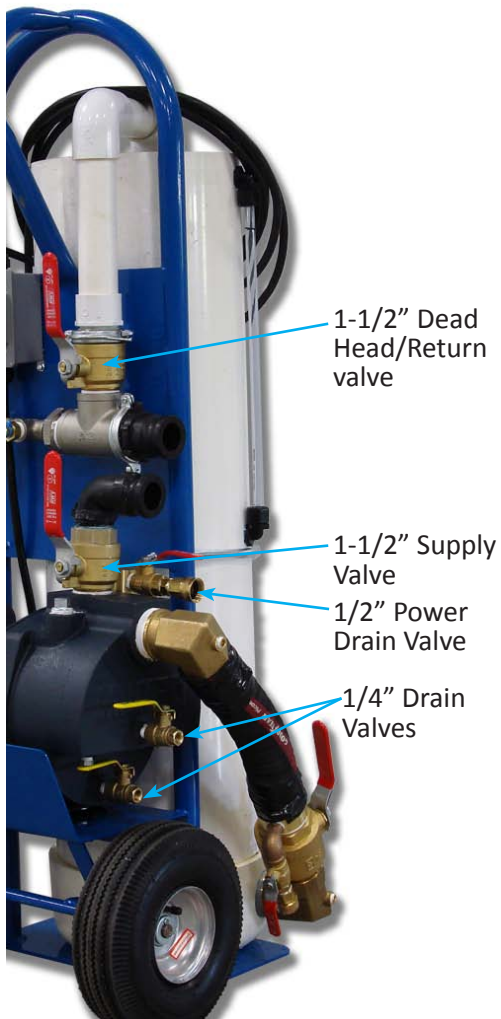

Figure 14: Flush Cart Valves in flushing steps

13. Allow the pump to operate until the fluid returning to the tank appears clear and free of air.
14. While the pump is running, “dead-head” the pump by turning off the dead-head/return valve (Figure 14). Then, quickly reopen the valve allowing the fluid to return to the tank. This process drives the loop pressure up thereby compressing any air remaining in the loop. Quickly opening the valve creates a sudden high velocity surge that helps dislodge air into the fluid stream where it can be returned to the tank.
15. Repeat the dead-head process 2-3 times over a period of 15 minutes. If necessary, add more fluid to the tank so the fluid level is visible in the sight tube.
16. With the pump continuing to run, mark the fluid level in the tank with the O-ring on the sight tube.
17. Close the 1-1/2” dead-head valve (Figure 14) while watching the fluid level in the sight tube. The dead-head process drives the static loop pressure to approximately 50 psi. Since fluid is incompressible but air can be compressed, this procedure shows whether air remains in the loop. In general, the fluid should not drop more than about 3/8” to 3/4” on a typical residential system. The slight drop in fluid is due to the expansion of the ground loop piping, and the actual drop will depend on the loop size (i.e. how much total pipe is in the loop) and fluid temperature.
18. Open the 1-1/2” dead-head valve (Figure 14) and allow the fluid to continue to circulate.

NOTE: If the preceding procedure is unsuccessful in removing all air from the loop, power flushing may be necessary. Proceed to the section of this document entitled “Power Flushing.”

19. Rotate 3-way valves on flow center so that the ground loop is isolated and fluid is directed toward the heat pump only. Figure 15 shows examples of how the valves may be oriented. This will vary depending on the flow center and installation.

20. Repeat Steps 11 through 17 above to ensure that all air has been purged from the heat pump circuit.
21. Rotate 3-way valves on flow center so that the fluid is directed toward both the ground loop and heat pump. Figure 16 shows examples of how the valves may be oriented. This will vary depending on the type of flow center installed.
22. Repeat steps 11 through 17 above to ensure that all air has been purged from the ground loop and heat pump system.

NOTE: If you suspect that the loop system is contaminated with very fine sand, silt, or clay, additional loop filtration is necessary. Proceed to the section of this document entitled “Fluid Filtering”.

23. Close the 1-1/2” dead-head valve (Figure 14).
24. Close the 1-1/2” supply valve (Figure 14) to trap pressure in the system. Turn off the pump.
25. Using a large flat head screwdriver, slightly open the vent screw on the face of the Grundfos pump(s). After a few drops of water escapes, retighten the screw.

NOTE: This step is critical. Opening the vent screw and allowing fluid to drip out ensures that all trapped air has exited the pump motor. Skipping this important step could lead to premature pump failure.

26. Monitor the pressure gauge for 10-15 minutes. The pressure should not drop substantially (typically no more than 3-4 psi). The slight pressure drop is due to the loop pipe relaxing and is normal. If there is substantial pressure drop there is likely a leak in the system. Inspect all piping connections in the mechanical room for signs of fluid and correct any issues discovered. If there is a leak in a flush cart connection the flush cart should be isolated from the system as shown in step 27. Then, the pressure gauge can be installed in a P/T port at the heat pump to monitor pressure.

27. If installing a pressurized system, rotate the 3-way valves so that the flush cart is isolated from the system. Figure 17 shows an example of how the valves may be oriented. This will vary depending on the type of flow center installed.

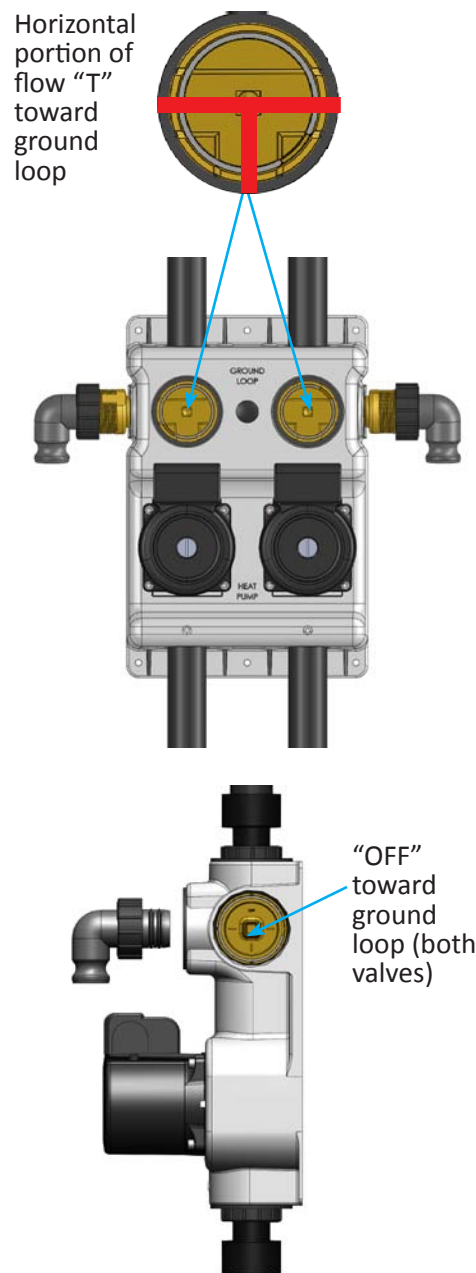

Figure 15: FPT flow center (top) and Flo-Link Double O-ring flow center (below) valve positions for ground loop isolation

28. Open the 1-1/2" Supply and Return valves (Figure 14) to relieve the pressure in the hoses.
29. If using the flush cart hoses with 1-1/4" ball valves, close the ball valves.
30. Disconnect the hoses from the flow center.

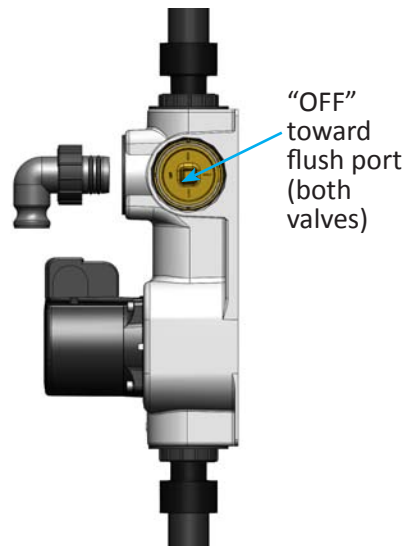
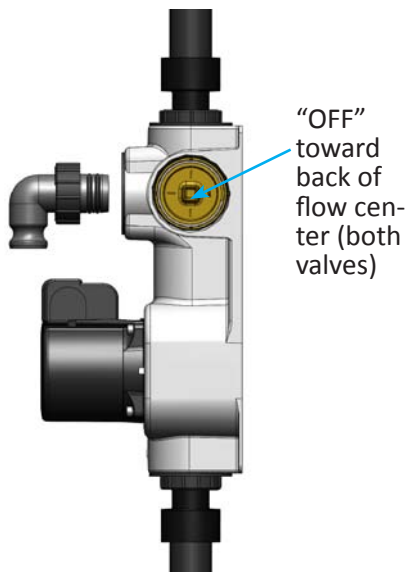
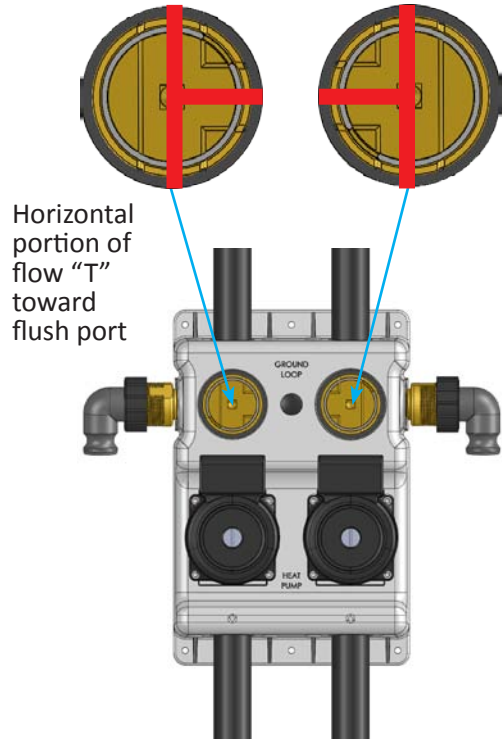
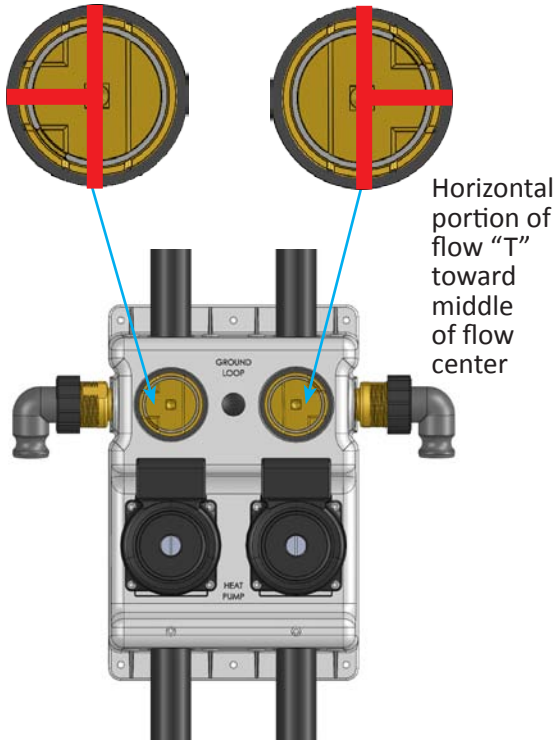

Figure 16: FPT flow center (top) and Flo-Link Double O-ring flow center (below) valve positions to allow flow to both the ground loop and the heat pump

Figure 17: FPT flow center (top) and Flo-Link Double O-ring flow center (below) valve positions in operating position

Power Flushing

Power flushing is a technique that can be utilized to help purge air from a ground loop when the standard flushing procedure does not eliminate all air from the loop. This procedure utilizes the flush cart pump and municipal water pressure together to provide maximum system pressure to compress and purge air pockets. The following procedure describes this process and assumes that steps 1-18 in the Standard Flushing/Purging section have been completed.

1. Be sure there is sufficient capacity in the tank to add more fluid. If necessary, remove fluid from the tank before proceeding.
2. With the pump running, close the 1-1/2" dead head valve (Figure 18) and 2" tank isolation valve (Figure 19), and open the 1/2" fill valve (Figure 19).
3. Monitor the pressure; it will quickly climb to 80-100 psig.
4. When the pressure reaches 80-100 psig, close the 1/2" fill valve (Figure 19). Then, open the 1-1/2" dead head valve (Figure 18) and the 2" tank isolation valve (Figure 19) simultaneously.
5. Repeat steps 1-4 above.
6. Return to step 16 of the Standard Flushing/Purging section.

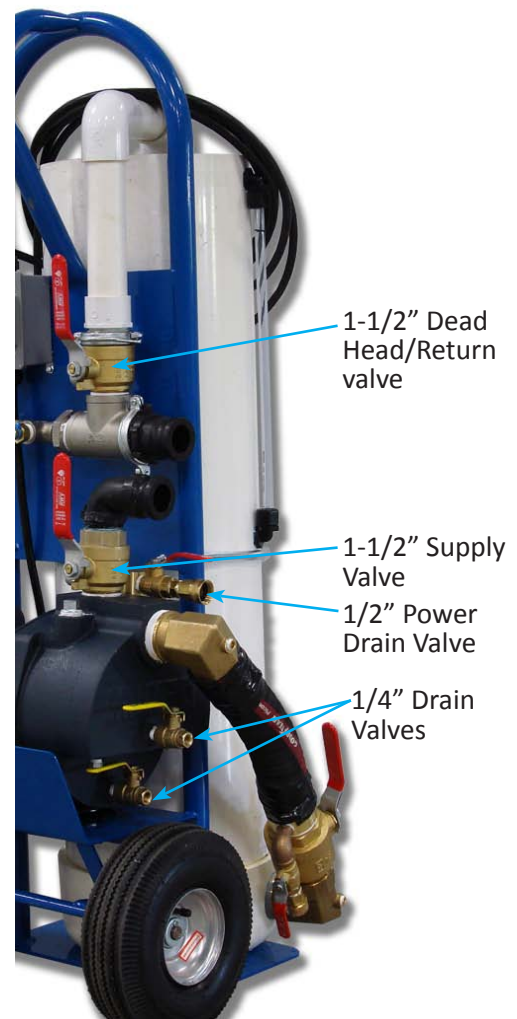

Figure 18: Flush Cart Valves in flushing steps



Figure 19: Fill Valve/Tank Isolation Valve

Fluid Filtering

The circulation pumps used in closed loop geothermal systems require clean fluid to operate properly and reliably. The standard 100 micron filter provided with the flush cart is acceptable for capturing relatively large debris such as pipe shavings, gravel, and medium sand particles. In certain installation locations other smaller materials such as fine sand, silt and clay may be present in the water supply or introduced to the loop system during installation. These fine particles can travel to the circulation pumps used during system operation possibly causing erosion of the pump housing and/or a locked rotor and pump failure. Debris in the closed loop system is a leading factor in premature pump failure. Therefore, it is good practice to always preform additional fluid filtration to ensure the clearest fluid possible before completing a system installation. The following procedure assumes that steps 1-22 of the Standard Flushing/Purging section have been completed.

NOTE: Prior to using the one micron filter, rinse it thoroughly with clean water to remove any residual debris from the manufacturing process.

1. Turn off the pump and drain fluid from the tank until the level is below the bottom of the filter (make sure that the level does not drop below the suction inlet to the pump). This step is necessary to prevent debris captured in the 100 micron filter bag from being reintroduced into the tank. If possible, capture the fluid drained from the tank in a container so it can be added back to the tank in step 3.
2. Replace the 100 micron filter with a one micron filter.
3. Replace the fluid removed in step 1 to refill the tank to the level it was before filter replacement.
4. Rotate the valves on the flow center to direct the fluid to the ground loop only. Figure 12 shows examples of how the valves may be oriented. This will vary depending on the type of flow center installed.
5. Run the flush cart for at least 30 minutes, while monitoring the filter. This very fine filter will catch clay, sand and other debris. If the filter overflows during the process, stop the pump and clean the filter as necessary. Continue until the loop fluid is completely filtered. Clean the 100 micron filter with clean water while the one micron filter is being used. Rotate the valves on the flow center to direct the fluid to the heat pump and allow the pump to run for another five minutes. Figure 15 shows examples of how the valves may be oriented. This will vary depending on the type of flow center installed.
6. Turn off the pump and drain fluid from the tank until the level is below the bottom of the filter (make sure that the level does not drop below the suction inlet to the pump). This step is necessary to prevent debris captured in the one micron filter bag from being reintroduced into the tank. If possible, capture the fluid drained from the tank in a container so it can be added back to the tank in step 8.
7. Replace the one micron filter with a clean 100 micron filter.

8. Replace the fluid removed in step 6 to refill the tank to the level it was before filter replacement.
9. Return to step 21 of the Standard Flushing/Purging section.

NOTE: Dead-heading the pump to check for air in the loop system is not possible with the one micron filter in place. The fluid in the tank is drawn down from the tank faster than it passes through the filter. Therefore, if the pump is dead-headed with the one micron filter in place, the fluid level in the tank around the filter drops while the fluid level in the filter remains at a higher level. After filtering with the one micron filter and re-installing the 100 micron filter, it is important to repeat the dead-heading procedure described in the Standard Flush/Purging section to ensure air did not enter the system during the filtering process.

Adding Antifreeze

Antifreeze is used in a ground loop system when the loop fluid entering the heat pump (EWT) is expected to drop below 40 degrees Fahrenheit. In general, antifreeze is added at concentration high enough to achieve a freeze protection level that is 10 degrees lower than the lowest expected entering fluid temperature (EWT) to the heat pump. For example, if the lowest design or expected EWT is 35F, antifreeze is added to achieve a freeze protection level of 25F (see table 1). Adding too much antifreeze will result in reduced loop capacity and increased pump power consumption. The freeze protection level depends on the type and concentration of antifreeze. The antifreeze types most commonly used are methanol, ethanol, and propylene glycol. Pure methanol and ethanol are extremely flammable and the fumes can ignite. Extreme care must be exercised when handling these chemicals.

Table 2 provides the flash point of ethanol and methanol solutions. The flash point is the lowest temperature where the alcohol will evaporate enough to form a combustible concentration of gas. Therefore, the flammability of ethanol and methanol antifreeze solutions depends on the temperature of the mixture. Pure methanol or ethanol should never be mixed in an enclosed area. Since the flash point of propylene glycol is above the boiling point of water, there is little fire hazard in storage or handling. Geo-Flo recommends using only pre-mixed alcohol antifreezes in a non-flammable state or propylene glycol at the job site. Some municipalities restrict the use of certain antifreeze solutions in the ground loop system so be sure to check with state and local authorities.



WARNING: ONLY USE PREMIXED ANTIFREEZE IN A NON-FLAMMABLE STATE. FAILURE TO OBSERVE SAFETY PRECAUTIONS MAY RESULT IN FIRE, INJURY, OR DEATH.

Antifreeze	% by vol	Freeze Protection deg F	Specific Gravity 30 deg F
Methanol	10.0%	19.7	0.987
	12.5%	16.2	0.985
	15.0%	12.6	0.982
	17.5%	8.8	0.980
	20.0%	4.9	0.977
Ethanol	15.0%	22.6	0.985
	20.0%	18.1	0.980
	25.0%	12.9	0.974
	30.0%	7.0	0.970
Propylene Glycol	15.0%	22.5	1.015
	20.0%	18.4	1.022
	25.0%	13.8	1.026
	30.0%	8.8	1.035

Table 1: Freeze protection and specific gravity for common ground loop antifreeze mixtures (source: Geo-Flo Calculator apps, www.geo-flo.com)

% by vol	Flash Point, deg F	
	Ethanol	Methanol
10%	120	130
20%	97	110
30%	84	95
40%	79	85
50%	75	75
60%	72	70
70%	70	60
80%	68	54
90%	63	54
100%	63	54

Table 2: Flash point* for ethanol and methanol mixtures (source: engineeringtoolbox.com)

*The flash point of a chemical is the lowest temperature where it will evaporate enough fluid to form a combustible concentration of gas. The flash point is an indication of how easy a chemical may burn.

Pump and Dump Method of Adding Antifreeze

1. Calculate the amount of antifreeze needed to achieve the freeze protection required for the system. Geo-Flo provides a free on-line calculator (go to any of the pressure drop calculators at www.geo-flo.com) to assist in determining the quantity and freeze protection level of the antifreeze chosen for a particular installation. Table 1 provides freeze protection levels for ethanol, methanol, and propylene glycol.
2. Attach a hose to the 1/2” pump & dump valve (Figure 20). Direct the opposite end of the hose to an appropriate drain.
3. Rotate the flush valves on the flow center to direct fluid to the ground loop only (Figure 12). Since most of the loop fluid is in the ground loop, most of the antifreeze would likely dump down the drain if antifreeze were introduced toward the heat pump.
4. Open the 1-1/2” supply valve (Figure 20).
5. Close the 1-1/2” dead head valve (Figure 20). This prevents fluid from returning to the tank.
6. Slightly open the 1/2” pump & dump valve (Figure 20).
7. Energize the pump. The water from the tank/loop is pumped to the drain. Closely monitor the fluid level in the tank and turn off the pump before the fluid level drops below the suction pipe so air is not drawn into the system. If air is drawn into the system, the flushing procedure described above must be repeated.

8. Carefully add the antifreeze fluid to the tank. Propylene glycol can be poured directly into the top of the tank. However, methanol and ethanol should be handled with extreme caution. These chemicals should never be poured directly into the top of the flush cart tank when the flush cart is located in an enclosed space such as a home or mechanical room. Pure methanol and ethanol are extremely flammable and the fumes can ignite. ***Always pre-mix alcohols before taking them to the job site.*** For example, if the desired concentration of methanol is 12.5% (16.2 deg. F freeze protection), bring a 25% mixture to the job site, and simply use four times as much of the mixture vs. pure methanol. Extreme care must be exercised, especially in hot weather, as 25% methanol by volume has a flash point of about 100 deg. F.
9. Energize the pump. The water from the tank/loop is pumped to the drain while the antifreeze is pumped to the ground loop. Closely monitor the fluid level in the tank and turn off the pump before the fluid level drops below the suction pipe so air is not drawn into the system. If air is drawn into the system, the flushing procedure described above must be repeated.
10. Repeat steps 8 and 9 until the required antifreeze has been added to the loop.
11. Close the 1/2" pump and dump valve (Figure 20).
12. Open the 1-1/2" supply valve (Figure 20) and energize the pump to mix the antifreeze with the water in the loop.
13. Rotate the flush valves on the flow center to direct the fluid to both the heat pump and the ground loop to allow the antifreeze to mix. Allow the pump to run until the fluid is thoroughly mixed. If installing a pressurized flow center, pressurize the system as described in the Standard Flushing/Purging Procedure section of this document.

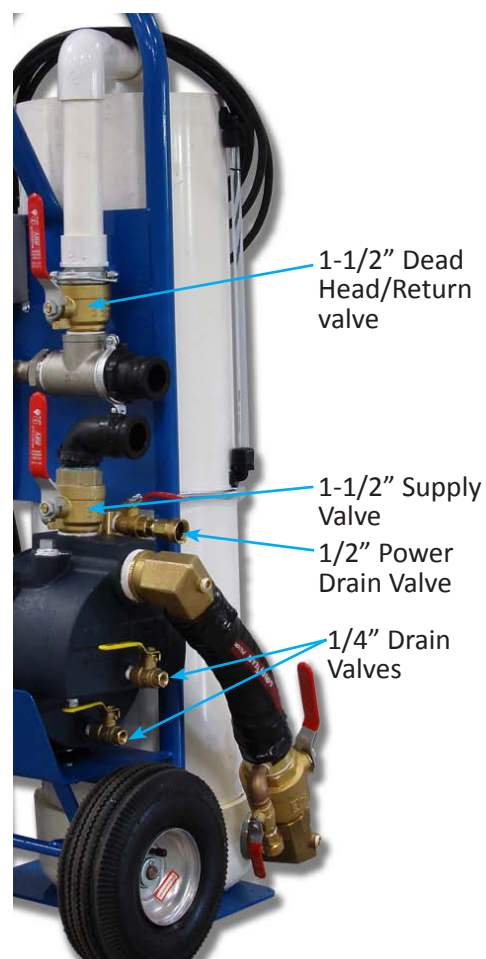
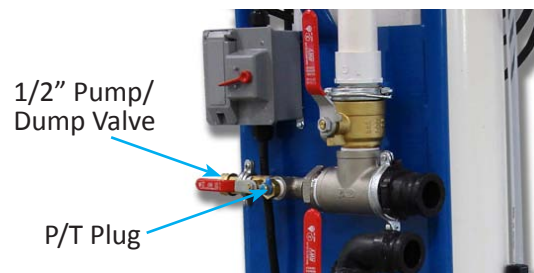

Figure 20: Flush Cart Valves in adding antifreeze steps



WARNING: ONLY USE PREMIXED ANTIFREEZE IN A NON-FLAMMABLE STATE. FAILURE TO OBSERVE SAFETY PRECAUTIONS MAY RESULT IN FIRE, INJURY, OR DEATH.

Verifying Antifreeze Concentration/ Freeze Protection

The antifreeze concentration is checked using a specific gravity hydrometer or refractometer. Be sure to use the proper specific gravity hydrometer for the antifreeze type used. Table 1 and Figures 21 through 24 provide specific gravity versus freeze protection for methanol, ethanol, and propylene glycol.

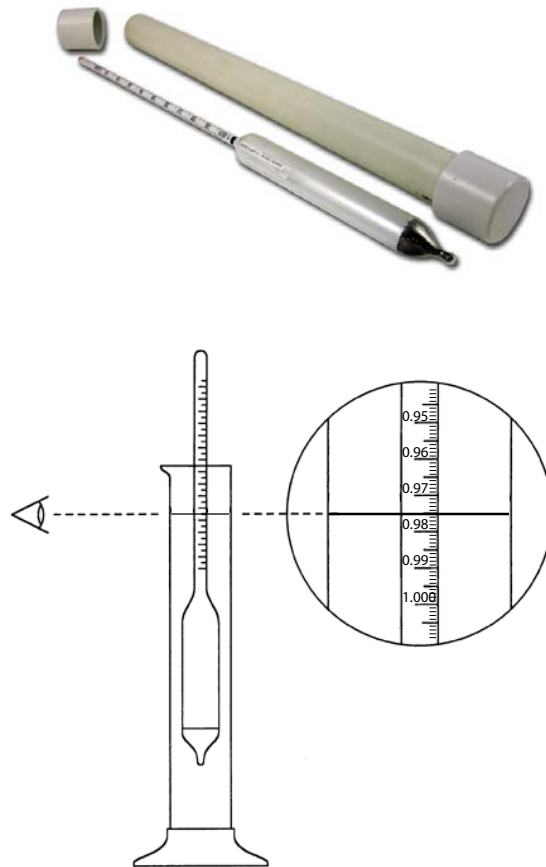

Figure 21: Typical hydrometer (above); reading a hydrometer (below). In the example, this hydrometer would be read as 0.975, approximately 25% ethanol by volume. NOTE: There are two types of hydrometers, one for fluids lighter than water (ethanol and methanol); and one for fluids heavier than water (propylene glycol).

Figure 22: Freeze protection for common ground loop antifreeze mixtures (source: Geo-Flo Calculator apps, www.geo-flo.com)

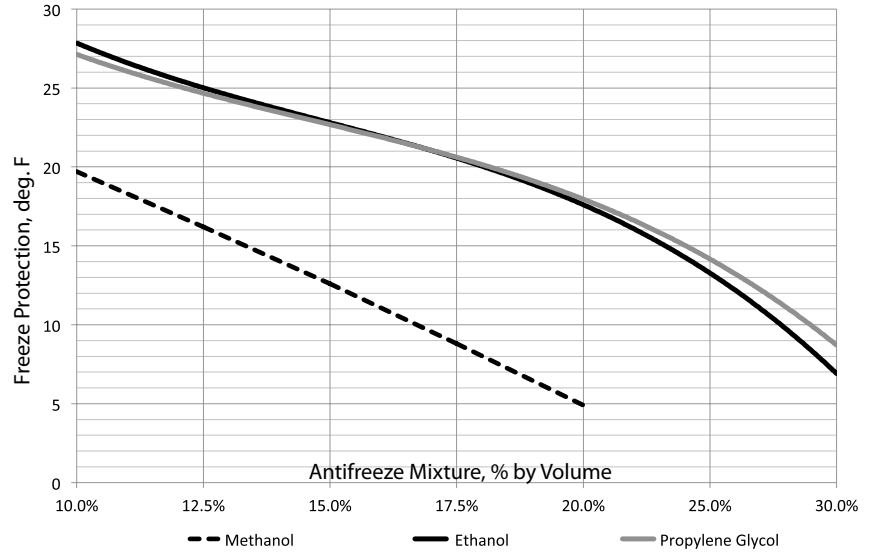

Figure 23: Specific gravity for alcohol-based antifreezes over a range of freeze protection temperatures (source: Geo-Flo Calculator apps, www.geo-flo.com)

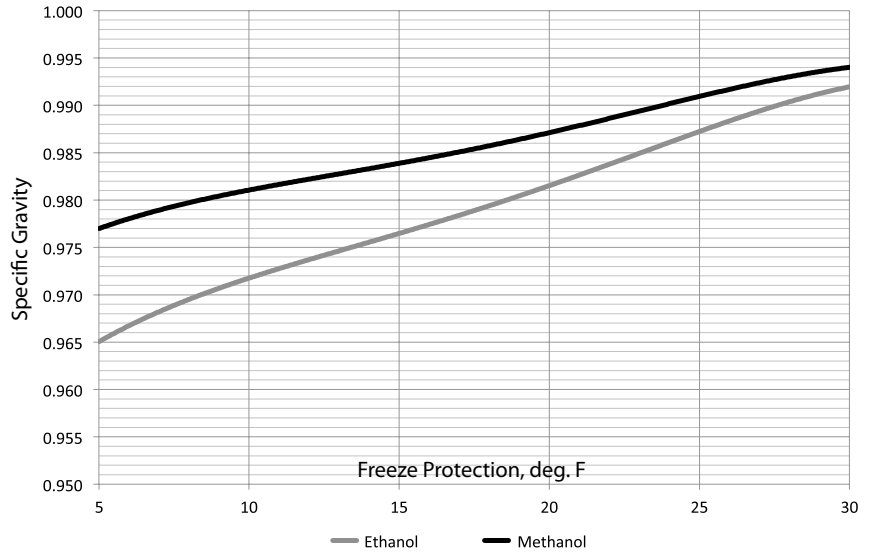
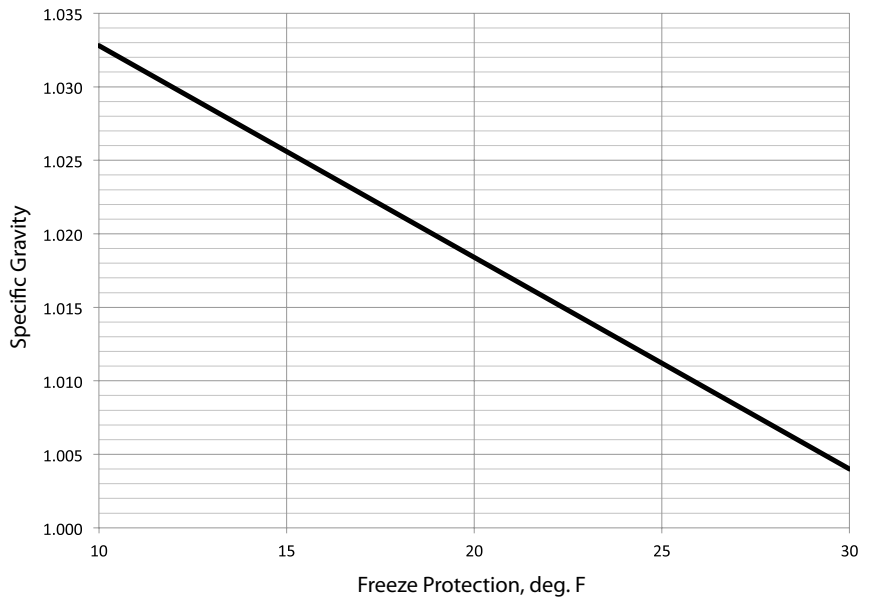

Figure 24: Specific gravity for propylene glycol over a range of freeze protection temperatures (source: Geo-Flo Calculator apps, www.geo-flo.com)



Water Quality

Unfortunately for some system owners, water quality is not considered for closed loop systems. One of the leading causes of premature pump failure is poor water quality. Water quality related to pump or system component failure may be categorized into four areas of concern, namely:

- **Suspended Solids**: Suspended solids can include dirt, silt, sand, biological growth, insoluble organic matter, and iron. Suspended solids act like sandpaper in the system. *It is common to see examples of suspended solids in pump tear-down analyses of warranty returns.*
- **System Insufficiently Purged of Air**: Oxygen in the system attacks ferrous materials (cast iron volutes, steel piping in commercial buildings, etc.).
- **pH level**: As the pH of the system water increases (moves toward the alkaline side of the scale), the corrosiveness of the water decreases. However, as the pH of the water increases, the formation of scale increases. Low pH is acidic; high pH is alkaline. According to the *2011 ASHRAE Handbook -- HVAC Applications*, normal system pH should be in the 6.5 to 9.0 range.
- **Hardness**: As the hardness of the system water increases, the corrosiveness of the water decreases. However, as the hardness of the system water increases, the formation of scale increases.

Poor water quality can affect pumps and system components in a number of ways. Heat pump heat exchanger failure or pump volute corrosion is typically a result of low system pH level. However, water hardness is also a problem with regard to pump bearing failure, plugging of valves/orifices, and coating of system surfaces (decreased heat exchange).

Determining water quality requires testing a sample. In most cases, contractors only need to do two to three water quality tests to get a general feel for the water quality in the area. For example, if most of the geothermal applications are in a 30 mile radius, there may only be two to three municipal water systems in the service area.

Table 3 provides water quality guidelines to help protect the loop pump(s) from premature failure, assuming that all debris is filtered from the system fluid. However, following these guidelines will also help protect the heat pump heat exchanger and other system components.

It is important to choose a testing company that can provide a water quality analysis that is pertinent to HVAC applications. Figure 25 shows an example report from Rocky Research in Boulder City, Nevada (<http://rockyresearch.com>, 702-293-0851).

In certain parts of North America, bronze or stainless steel volutes are popular. In most cases, water treatment or the use of antifreeze (with corrosion inhibitors) at start up is significantly less expensive over time than installing a more corrosion-resistant material, even if antifreeze is not needed for freeze protection (Southern climates). Selection of bronze or stainless steel will prolong the service life of the pump volute, but there are other components in the system that will be attacked by the harsh system water.

Measurement	Limits	Source
Hardness	< 14 gr/gal	Grundfos
Total dissolved solids	filtered for max. of 1 micron	See Table 2
pH	6.5 - 9.0	ASHRAE
Sulfate	< 25 ppm	Rocky Research
Chloride	< 25 ppm	Rocky Research
Nitrate	< 75 mg/L	Rocky Research

Table 3: Water quality guidelines

Grains per gallon = ppm divided by 17.14
 mg/L = ppm

Soil Type	Grain Size*
Gravel	2,000 to 75,000 microns
Course Sand	425 to 2,000 microns
Fine Sand	75 to 425 microns
Silt-Clay	< 75 microns*
Clay	< 2 microns*

Table 4: Grain size

* Grain size is defined by the AASHTO soil classification system for the U.S. Bureau of Public Roads (now the Federal Highway Administration). Silt-Clay is the smallest grain size considered in the AASHTO system. ISO 14688-1 includes clay particles in the 2 micron and smaller range.

For the most part, there are two solutions to providing good system water quality, namely: 1) treatment of local water; or 2) transportation of water to the job site. In fact, most antifreeze manufacturers require de-ionized or distilled water as part of their warranty policy.

Treatment of local water can be difficult, especially if the local water quality is poor. Although water treatment systems may be rented or purchased, the expense is often high. Transporting water or using a pre-mix anti-freeze may be a better solution, especially considering the advantages. For example, pure methanol does not include corrosion inhibitors. Purchase of a pre-mix antifreeze could significantly improve system reliability if the water quality is controlled and there are additives in the mixture to inhibit corrosion. There are many examples of such fluids on the market today such as Dowfrost™ GEO (pre-mix propylene glycol), Environol™ 1000 (pre-mix ethanol), and others.

When using a pre-mix water/antifreeze solution, extreme care must be exercised to keep dirt and debris out of the system. Since the fluid that will be used to fill/flush the ground loop will be the final system fluid, every attempt should be made to cap pipes and keep debris out of the system during loop installation. Note that the standard 100 micron filter on the Geo-Flo flush cart is acceptable for capturing relatively large debris such as pipe shavings, gravel, and medium sand particles but is not capable of catching very small particles. Geo-Flo provides a one micron filter for the flush cart that may be used for final clean-up once air is purged from the loop (see “Fluid Filtering” section). Table 4 provides particle size of various soil types, showing the value of utilizing a one micron filter.

If particulate matter is a concern, it may be advantageous to use local water for purging air and filtering debris from the system, and then use the “pump and dump” method for replacing the purging water with the pre-mix antifreeze solution. Consideration of water quality can eliminate many system failures and help maintain satisfied customers.

Installation Tip:
 Consider a pre-mix antifreeze solution to control system water quality.

Closed Loop Water Analysis

Customer Name	Heat Pumps 'R Us	Sample Number	ABC123
Job Name	GF3000000	Customer Sample No.	131
JobID	None	Collection Date	5/30/2013
Manufacturer	None	Collected By	Service Tech
Model Number	None	Receive Date	5/30/2013
Serial Number	0	Analysis Date	5/31/2013
Equipment Name	Closed Loop Cooling Water		
Equipment ID	GF650001		

	Sample Data		Limits
Sulfate	231	ppmS04	<25 ppmS04
Chloride	24	ppmCl	<25 ppmCl
Total Hardness	788	mgCaC03/L	<75 mgCaC03/L
Nitrite	0	mg/L	250- 1000 mg/L
Bicarbonate Alkalinity	270.9	as mg CaC03/L	
Carbonate Alkalinity	0	as mg CaC03/L	
Hydroxide Alkalinity	0	as mg CaC03/L	
Total Alkalinity	271	as mg CaC03/L	
pH	7.9		8.5-9.5
Total Dissolved Solids	667	ppm	<1000 ppm

MAINTENANCE RECOMMENDATIONS:

The sulfate level is above 25 ppm, which will contribute to corrosion. Total Hardness is above the limit, which will cause scale in the system. The pH is low, corrosion protection may be compromised. No corrosion inhibitors were detected. Replace the charge with distilled or deionized water to remove contaminants. A water treatment program with corrosion inhibitors and pH buffers is highly recommended.

Customer Comments: None

This report is based on a single sample. Sampling regularly and tracking the data provides the clearest insight to the solution chemistry of your unit. A large change in any result may make a resample advisable.

Figure 25: Sample water quality report (courtesy of Rocky Research)

Start-Up



WARNING: OPEN THE MAIN POWER SUPPLY DISCONNECT SWITCH AND SECURE IT IN AN OPEN POSITION PRIOR TO PERFORMING ELECTRICAL WORK. VERIFY THAT POWER HAS BEEN DISCONNECTED PRIOR TO WIRING THE PUMP(S). FAILING TO SECURE THE ELECTRICAL SUPPLY COULD RESULT IN SERIOUS INJURY OR DEATH.

Preparing Flow Center for Start-Up

1. Wire the circulator pumps to the heat pumps as shown in Figure 26. Follow all electrical and local codes for wiring and fuse/breaker sizing.
2. Open the vent screw in the center of each pump motor with a large flat head screwdriver allowing a few drops of fluid to drip out. Then, retighten the vent screw.

NOTE: Step #2 is critical. Opening the vent screw and allowing fluid to drip out ensures that all trapped air has exited the pump motor. Skipping this important step could lead to premature pump failure.

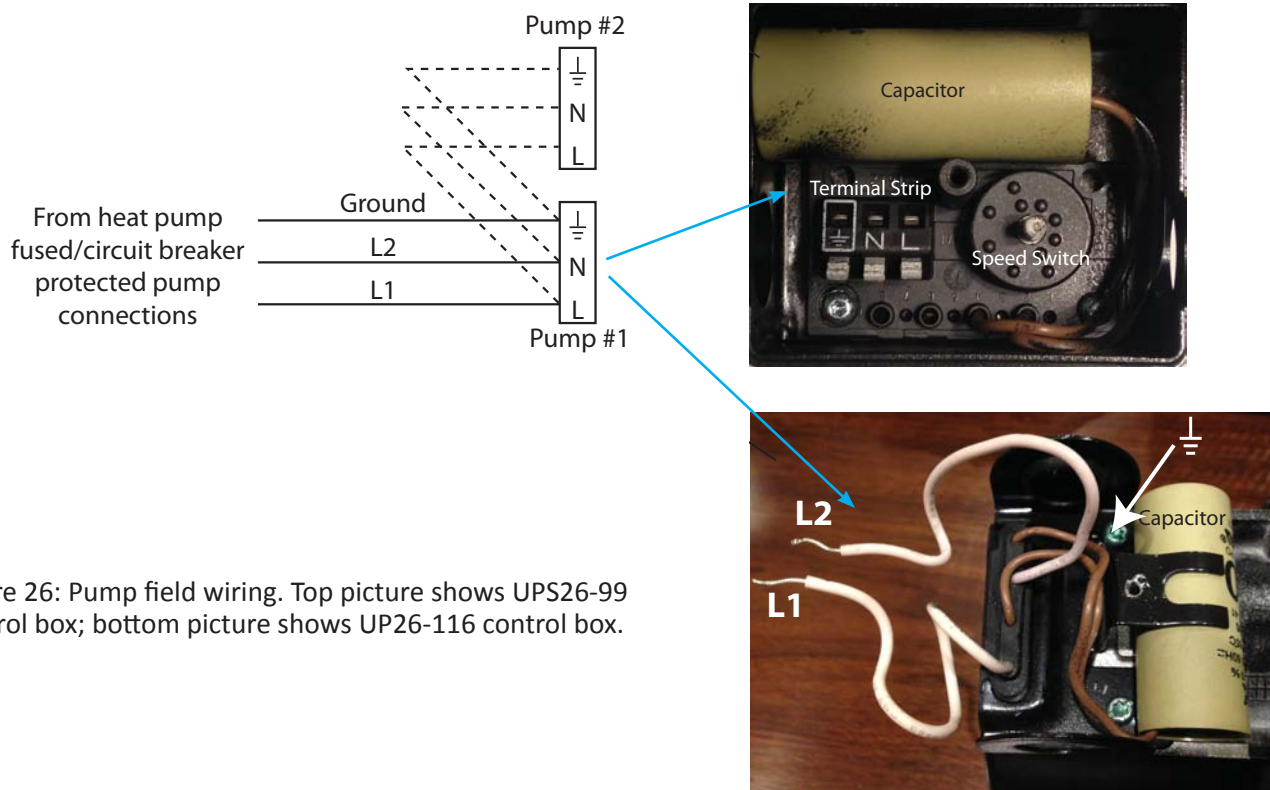

Figure 26: Pump field wiring. Top picture shows UPS26-99 control box; bottom picture shows UP26-116 control box.

3. Start all flow center pumps and allow system to operate for several minutes.
4. Measure and record the flow rate using the methods described in the following section of this document. If using UPS26-99 three speed pump(s), the flow can be adjusted by changing the pump(s) speed. The flow rate should be within the range suggested by the heat pump manufacturer.
5. Verify the performance of the heat pumps per the manufacturer’s literature by calculating the heat of extraction and/or rejection (HE-HR). The Geo-Flo website has a free calculator to assist in this calculation. Go to www.geo-flo.com, select Design Calculators then HE-HR Calculator. The HE-HR should be within the range specified by the heat pump manufacturer.
6. Install all valve face covers and flush port caps/plugs included in the hardware bag.

Measuring System Flow Rate -- Flow Rate from Pressure Drop

The system flow rate can be determined based upon the pressure drop across the heat pump’s heat exchanger.

1. Measure the pressure drop across the heat pump’s heat exchanger via the P/T ports located at the water connections of the unit (Figure 27). Use a single large dial face pressure gauge to allow for more precise measurement.
2. Determine the flow rate using the manufacturer’s published tables for pressure drop versus flow (Table 5). If the pressure drop is off the manufacturer’s chart, the flow rate can be determined using a free online calculator available on Geo-Flo’s website. Go to www.geo-flo.com, select Design Calculators then Flow Rate Calculator.

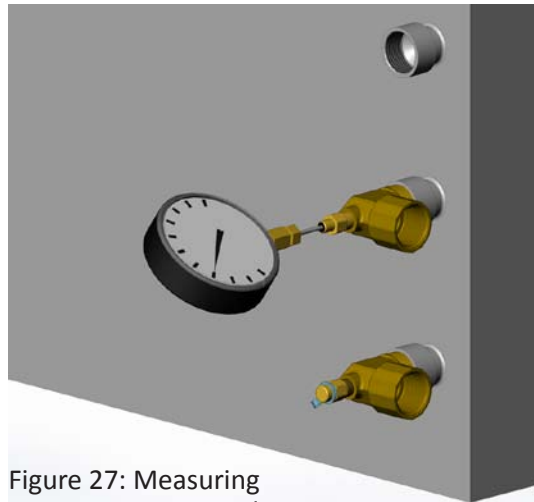

Figure 27: Measuring pressure drop

EWT °F	Flow gpm	WPD	
		PSI	FT
20	3.0	0.9	2.2
	4.5	1.8	4.2
	6.0	2.8	6.8
30	3.0	0.9	2.1
	4.5	1.7	4.0
	6.0	2.8	6.6
40	3.0	0.9	2.0
	4.5	1.7	3.9
	6.0	2.8	6.4
50	3.0	0.9	2.0
	4.5	1.6	3.8
	6.0	2.7	6.2

Table 5: Example of heat pump manufacturer’s table of pressure drop vs. flow rate

Maintenance

There is no regularly scheduled maintenance required for Flo-Link and GPM Series flow centers. However, there is maintenance associated with the ground loop that could affect pump longevity. The “Loop Pressurization” section below addresses ground loop pressure changes. If the pump does need to be replaced at some point in time, Geo-Flo offers a pump head replacement. The volute is foamed into the flow center, and would not typically be replaced.

Loop Pressurization

Ground loop temperatures in some climates can swing as much as 70 to 75 deg. F, which causes the ground loop piping to expand and contract. In summer, the pipe expands, causing the pressure to decrease in a pressurized system; in winter the pipe contracts, increasing the loop pressure. For years the industry recommended against expansion tanks, insisting that the PE pipe had enough expansion capability. In areas where loop temperatures are milder, it is possible that an expansion tank would not be needed. In most areas of North America, experience has shown that expansion tanks are needed. *Geo-Flo recommends either a **Pressure Battery** (polyethylene expansion tank) or a **Geo-Prime** tank on all pressurized systems* (see Figures 28 and 29) as a method of alleviating concerns with loop pressurization. The Geo-Prime tank acts as an expansion tank and air separator, effectively turning a pressurized system into a hybrid system (pressurized flow center with non-pressurized characteristics).

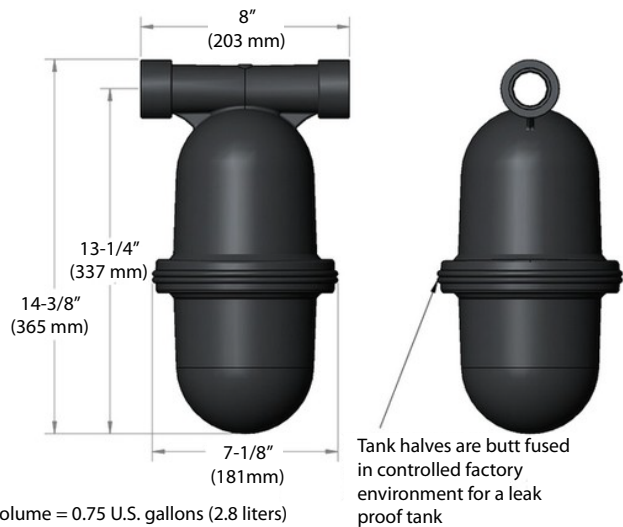

Tank Volume = 0.75 U.S. gallons (2.8 liters)

Figure 28: Pressure Battery Expansion Tank

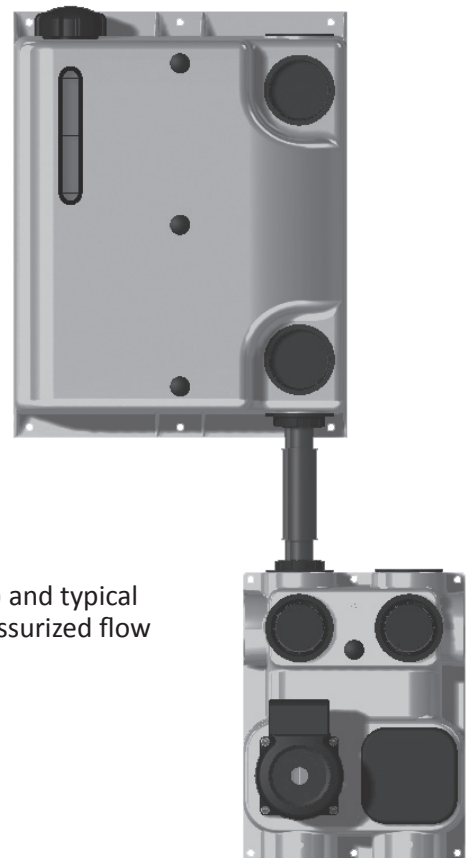
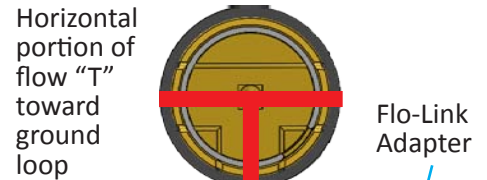

Figure 29: Geo-Prime Tank (left) and typical Geo-Prime installation with pressurized flow center (right)



Systems without a Pressure Battery or Geo-Prime Tank may need to be repressurized with a garden hose if the system falls below 10 to 15 psig. Otherwise, the temperature swing, and resulting pressure change could cause premature pump failure if the system pressure goes to zero. Any air in the system will exacerbate the problem. Grundfos circulators are cooled and lubricated by the fluid flowing through the pump. Figure 30 shows a typical “Loop Gooser” that allows the pressure in the ground loop to be increased by domestic water pressure via a garden hose through the heat pump P/T port. It is important to bleed air out of the garden hose before attempting to pressurize the loop. The ball valve should be opened so that a small stream is coming from the end of the “Loop Gooser” before inserting it into the P/T port to avoid introducing air into the system.

Figure 30: Loop Gooser assembly (allows garden hose attachment for increasing loop pressure)



Replacing Circulator Pump



WARNING: OPEN THE MAIN POWER SUPPLY DISCONNECT SWITCH AND SECURE IT IN AN OPEN POSITION PRIOR TO PERFORMING ELECTRICAL WORK. VERIFY THAT POWER HAS BEEN DISCONNECTED PRIOR TO WIRING THE PUMP(S). FAILING TO SECURE THE ELECTRICAL SUPPLY COULD RESULT IN SERIOUS INJURY OR DEATH.

1. Determine whether the circulator pump needs to be replaced. The pump motor should only be replaced after successfully troubleshooting the system and determining that the pump is not functioning. See Troubleshooting section of this document for more information.
2. Rotate both valves to isolate the ground loop. (Figure 31).
 - **Important (GPM series):** Rotate the left valve clockwise, and the right valve counter-clockwise to avoid reintroducing air into the loop from the flush port.
 - **Important (Flo-Link series):** Rotate the left valve counter-clockwise, and the right valve clockwise to avoid reintroducing air into the loop from the flush port.
3. Verify that power has been disconnected from the circulator pump(s) using a multi-meter.
4. Disconnect wiring from pump.
5. Remove screws holding pump motor to pump housing (volute), and remove the pump motor. Position a bucket underneath the pump to catch the fluid between the 3-way valve and the pump volute.

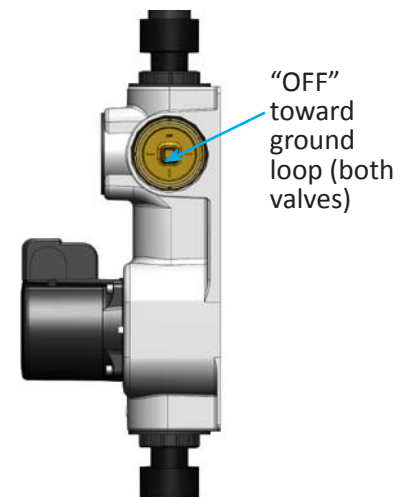
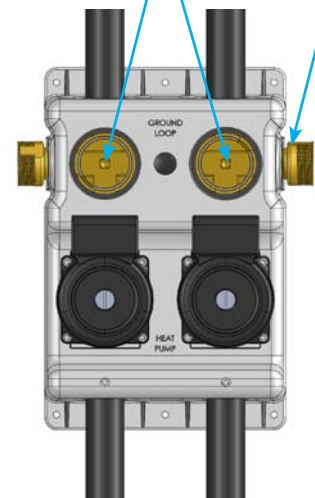

Figure 31: GPM (FPT) flow center (top) and Flo-Link Double O-ring flow center (below) valve positions for ground loop isolation

6. Inspect the pump motor and volute for signs that indicate the mode of failure. For example, if debris is present in the pump or volute, the ground loop should be re-flushed with a quality flush cart equipped with a filter.
7. Clean the pump seat on the pump housing (volute) with a cloth to remove any debris so that the gasket on the pump will seal properly. Install the new pump motor and reconnect wiring. Make sure that the terminal box is in the 12 o'clock, 3 o'clock, or 9 o'clock position to avoid potential motor failure due to condensation build-up inside the rotor can. See "Mounting the Unit" (Installation Section) for more information.

8. For GPM series, thread on the Flo-Link adapter (Figures 31 & 32), which provides a union connection and easier installation/removal of the garden hose adapter. This step is not necessary for Flo-Link flow centers. Figure 32 shows the fittings included with the loop flushing kit. This kit provides all of the adapters needed when originally flushing the loop, as well as the fittings needed when replacing a pump.

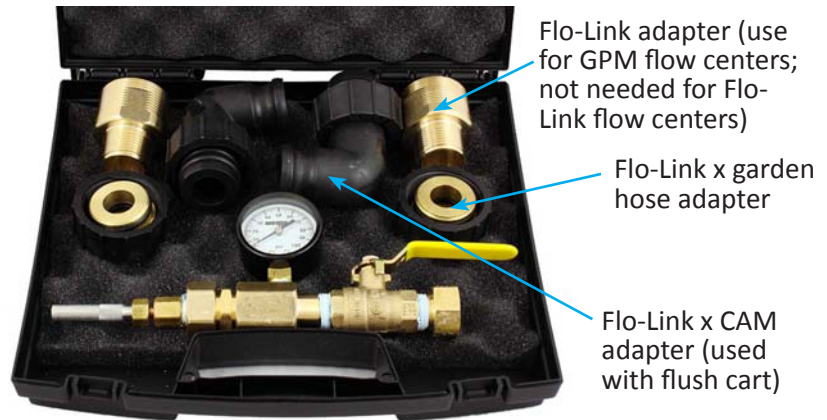

Figure 32: Geo-Flo Flush Kit

9. Connect the Flo-Link x garden hose adapters to the flow center. Using two garden hoses, connect one hose to each side of the flow center. Connect the left hose to a nearby water spigot; run the right hose to a drain. Do not turn the 3-way valves. When changing a pump, the flow center, heat pump, and connecting piping can be purged of air with a garden hose unless there is an excessive amount of pipe between the heat pump and the flow center. In most cases, a hose kit will be installed between the flow center and the heat pump.
10. Turn on the water and let the water run through the piping until all air has been purged from the piping.
11. Turn the right valve to normal operating position to turn off hose going to drain. **IMPORTANT: Do not turn off the water to the left hose in this step.**
 - GPM Series (FPT fittings): Rotate the right valve clockwise to turn off the flush port connected to the right hose (Figure 33). **NOTE: It is very important to turn the valve clockwise.** Otherwise, air could be reintroduced into the loop through the flush port.
 - Flo-Link Series (double O-ring fittings): Rotate the right valve counter-clockwise to turn off the flush port connected to the right hose (Figure 33). **NOTE: It is very important to turn the valve counter-clockwise.** Otherwise, air could be reintroduced into the loop through the flush port.
12. With the spigot to the left hose still on, pressurize the ground loop to the desired pressure (typically 30 to 50 psig).
13. Using a large flat head screwdriver, slightly open the vent screw on the face of the Grundfos pump(s). After a few drops of water escapes, retighten the screw.

NOTE: Step #13 is critical. Opening the vent screw and allowing fluid to drip out ensures that all trapped air has exited the pump motor. Skipping this important step could lead to premature pump failure.

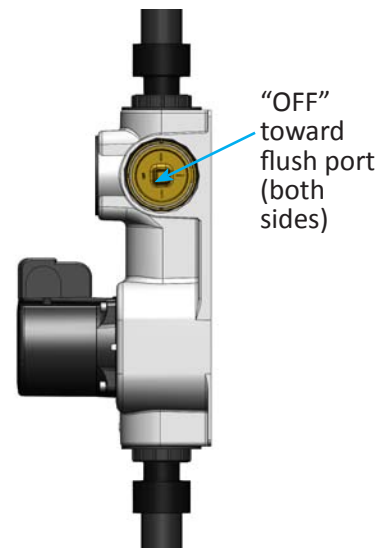
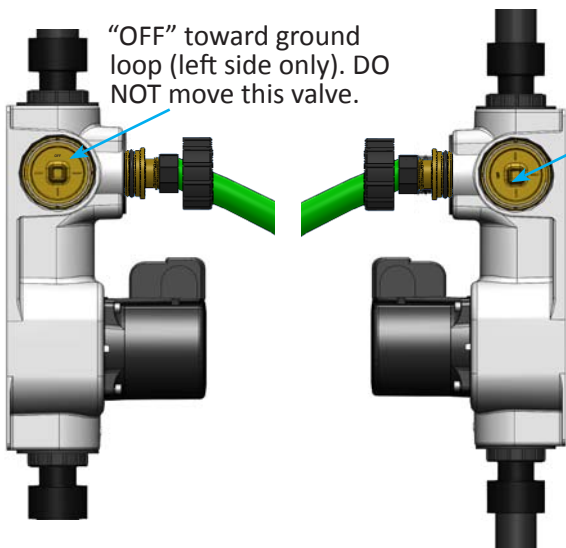
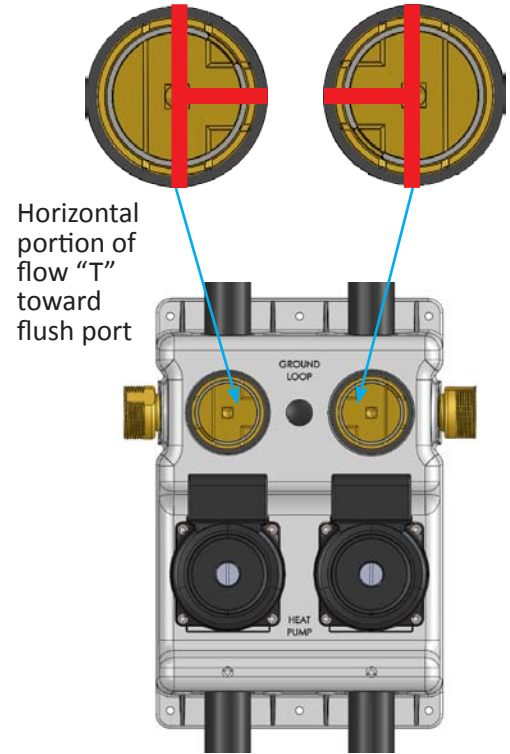
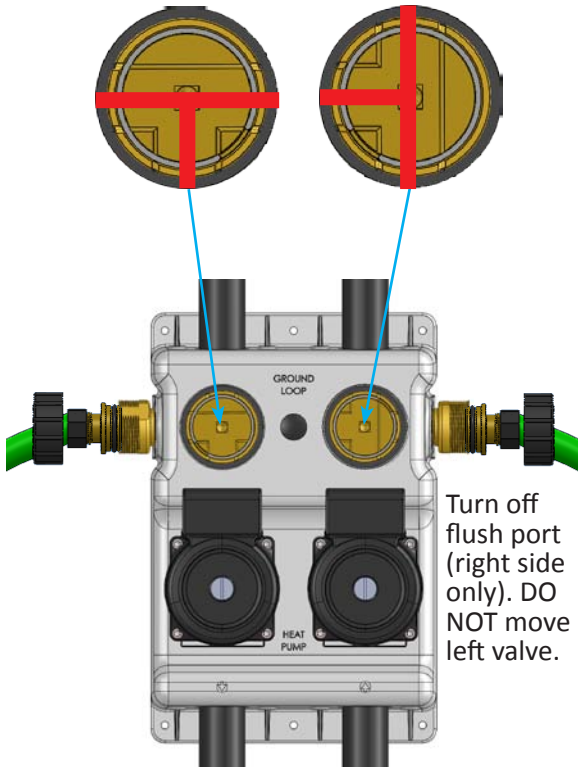

Figure 33: GPM (FPT) flow center (top) and Flo-Link Double O-ring flow center (below) valve positions for pressurization

Figure 34: GPM (FPT) flow center (top) and Flo-Link Double O-ring flow center (below) valve positions for normal operation

14. Rotate the left valve back to the operating position (Figure 34). Turn off the spigot to the left hose, and remove hoses and fittings from flow center.
15. Verify system performance by checking the flow rate and temperature differential, and comparing the values to the heat pump manufacturer's published data. If installing a UPS26-99 (3-speed) pump, be sure to set the pump speed that provides a flow rate within the manufacturer's recommend range.
16. Replace valve face covers and flush port plugs or caps.

Converting From GPM-1/FL1 to GPM-2/FL2

Follow procedure for Replacing Circulator Pump, except remove the blank plate instead of the pump motor. Be sure to remove the gasket (Figure 35).

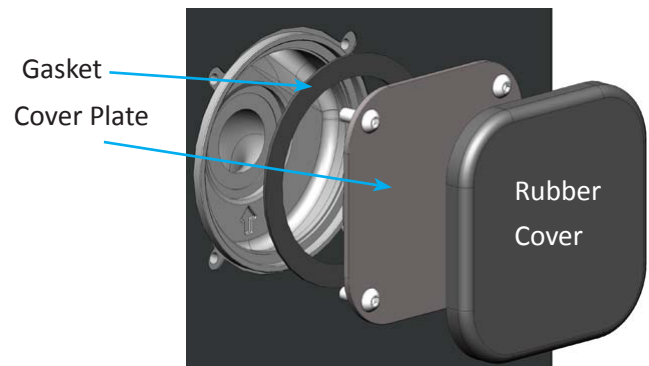

Figure 35: Removing cover plate

Troubleshooting

Problem	Possible Cause	Checks/Solution
No flow/lack of flow (always check pressure drop across coax to verify flow)	Valve(s) in wrong position	Rotate valve(s) to operating position
	Pump not operating	Ensure proper power/voltage at pump motor
	No power at pump	Ensure heat pump contacts are operating
		Reset fuse/breaker in heat pump
	Stuck/locked impeller	Remove vent screw; rotate shaft with small flat head screwdriver; if shaft will not rotate, replace pump motor.
	Frozen heat exchanger	Thaw heat exchanger; check/correct antifreeze level.
Power at pump but not operating	Remove vent screw and rotate shaft with a small screwdriver. Replace vent screw and re-energize pump.	
	Replace pump power head	
No/low system pressure	Pipe expansion	No problem; bump system pressure to acceptable level.
		Add expansion tank and/or antifreeze make up system
	Pipe expansion + Air in loop	Flush system; pressurize.
	Leak	Find and repair leak
Add antifreeze make up system		
Noise	Mechanical vibration due to pump motor resonance	Provide vibration isolation between: 1) piping and flow center 2) flow center and unit 3) flow center & mounting location (wall, heat pump, etc.)
	Air/debris in system	Flush loop
		Add air/dirt separator and expansion tank and/or anti-freeze make up system
	High velocity water: pump oversized or piping undersized	1) Use smaller pump 2) Turn pump speed down 3) Remove one of two pumps 4) Add flow restriction (ball valve) 5) Increase pipe size
	Pump cavitation	Increase pump suction pressure
	Pump motor noise-squealing	1) Vent pump; ensure not dry running.
2) Bearing failure: replace pump		
Valve Leak	Debris in valve	Rotate valve 360 degrees to dislodge debris
		Remove valve spool; clean valve body and spool; replace O-ring(s) on valve spool if necessary.
	Side loading valve spool when rotating with 3/8" drive tool	Rotate valve spool so that no side load is placed on spool
Pinched/twisted O-ring	Rotate valve 360 degrees to reseal O-ring	
Fluid leaks out valve face	Cut O-ring	Replace O-ring; kits and instructions are available.
	Pinched/twisted O-ring	Rotate valve 360 degrees to reseal O-ring

Troubleshooting continues on next page

Troubleshooting (Con'd)

Problem	Possible Cause	Checks/Solution
Fluid drips around adapter/fittings	Incorrect fitting used (i.e. threaded fitting instead of Flo-Link double O-ring fitting)	Replace incorrect fittings
	Poor fusion joint	Replace joint
	Condensation	Insulate piping
	O-ring seal failure (Flo-Link fittings)	Remove fitting; clean valve port and fittings; replace O-rings if necessary.
	Pipe misalignment; side-loading O-rings (Flo-Link fittings)	Remove fittings; check O-rings and replace if necessary; align and support piping
	Leak at threaded (MPT) fitting	Tighten MPT adapter (if possible) Replace fitting
Fluid leaks out "Heat Pump" end of flow center	Condensation	Insulate piping/fittings
	Cracked flange: over tightening MPT fitting (flanged FPT flow center)	Replace flow center
	Leak from above dripping down through flow center and out bottom holes	Investigate further; see other fluid leak troubleshooting items in this section.
	Internal leak-volute corrosion/erosion due to poor water quality	Replace flow center
	Internal leak-seal failure due to high temperature	Replace flow center; check wiring to be sure pump is not powered continuously.
Fluid leaks out "Ground Loop" end of flow center	See above for "Heat Pump" leak (except cracked flange)	See above for "Heat Pump" leak
Fluid leaks out of cabinet (out back, around valve, around pump, etc.)	Leak from above dripping down through flow center and out path of least resistance	Investigate further; see other fluid leak troubleshooting items in this section.

Manual Updates Table

Date	Description of Changes	Pages
07FEB2014	Complete re-write; added Flo-Link flow centers	All
OCT2008	Updates for product changes	Various
1998	First published	All



Installation, Operating, and Maintenance Manual Flo-Link™ and GPM Series Pressurized Flow Centers

Members of ...



Geo-Flo Products Corporation is continually working to improve its products. As a result, the design and specifications of products in this document may change without notice and may not be as described herein. For the most up-to-date information, please visit our website, or contact our customer service department at jmoan@geo-flo.com. Statements and other information contained in this document are not express warranties and do not form the basis of any bargain between the parties, but are merely Geo-Flo's opinion or commendation of its products.