

CONVERSION INSTRUCTIONS

NATURAL GAS TO LP (SEA LEVEL TO 2000 FEET)

CAST IRON GAS FIRED BOILERS

15B, BWB, UH15B, GMGWB

FOR FORCED HOT WATER

⚠ WARNING

Conversion kit shall be installed by qualified service agency in accordance with manufacturer's instructions and all applicable codes and requirements of authority having jurisdiction. If information in these instructions is not followed exactly, a fire, explosion or production of carbon monoxide may result in serious injury or death. Qualified service agency is responsible for proper installation of this kit.

Tools Required

Flat Head Screwdriver, 1/4" Nut Driver, 7/16" Open Ended Wrench, 3/16" Allen Wrench, 18" Manometer (or dial manometer)

Installation

1. Turn off gas supply to the boiler.

⚠ WARNING

Electrical shock hazard. Turn OFF electrical power supply at service panel before making electrical connections. Failure to do so could result in death or serious injury.

2. Turn off all electrical to boiler.
3. Remove front panel.
4. Remove burner access door.
5. Remove main gas burner tubes. See Figure 1.
6. Remove main burner orifices. See Figure 1.
7. Install supplied LP gas main burner orifices. See Table 3 for orifice size and quantities.
8. Use 7/16" wrench, disconnect pilot tube from pilot. See Figure 2.
9. Remove pilot orifice. See Figure 2.
10. Install LP gas pilot orifice. See Figure 2.
11. Apply liquid sealing compound to threads of pilot assembly fitting.
12. Attach pilot tube to pilot and securely tighten. See Figure 2.
13. Replace main gas burner tubes.
14. Remove cover screw from gas valve pressure regulator. See Figure 3.

Table 1 - KIT CONTENTS

ITEM	QTY.
Installation Instructions	1
Conversion Plate/Label	1
Pilot Orifice - Spark	1
Pilot Orifice - 24 Volt	1
Liquid Sealing Compound	1
Spring Kit	1

Table 2 - PILOT ORIFICES

MFG.	PART NUMBER
Honeywell	390686-36*

* Use 390686-40 for Boilers made before July 2008 using Q381 pilot.

Figure 1 - Burners

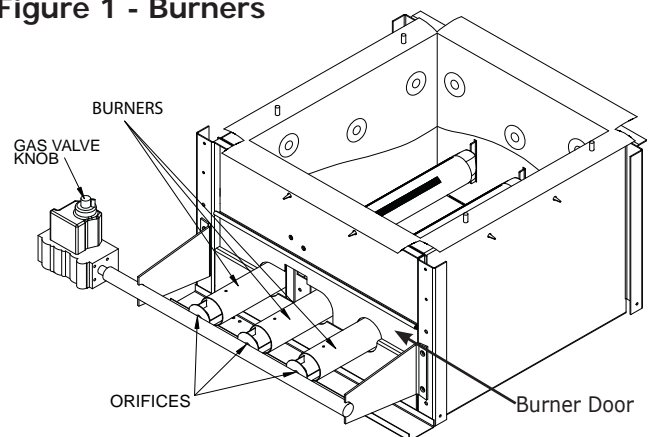
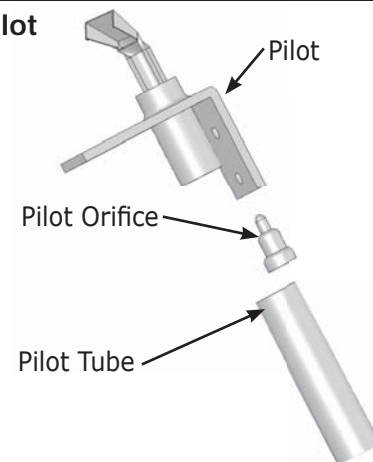



Figure 2 - Pilot



NATURAL GAS TO LP CONVERSION INSTRUCTIONS

15. Remove adjustment screw by turning counterclockwise . See Figure 4.
16. Remove stainless steel Natural gas spring. See Figure 4.

NOTICE

Parts for steps 17, 18, 26, and 27 are located in the Honeywell Lp gas conversion kit HW#393691 for VR8200, VR8204, VR8300 and VR8304 gas valves.

17. Insert Red LP gas spring. See Figure 4.
18. Install new adjustment screw. Assure the screw top is flush with the regulator top. See Figure 4.
19. Turn pressure regulator adjustment screw clockwise  eleven (11) complete turns. This is starting point for manifold pressure.)
20. Install manometer to pressure tap on outlet side of gas valve. See Figure 3.
21. Turn electric and gas supply ON.

NOTICE

Gas inlet pressure is between minimum of 11" w.c. and maximum of 14" w.

22. Check for gas leaks around all gas connections using commercially available soap solution specifically made for leak detection.

⚠ DANGER

Fire Hazard. Do not use matches, candles, open flames, or other methods providing ignition source. Failure to comply will result in death or serious injury.

23. While boiler is operating adjust manifold pressure to 11" water column by turning pressure regulator adjustment screw. Check for CO₂ and CO levels to assure proper operation.
24. Turn OFF electric and gas supply.
25. Remove manometer. Replace pressure tap cover screw securely.
26. Install black LP gas regulator adjustment cover screw with o-ring. See Figure 4.
27. Mount conversion label on gas valve.
28. Turn electric and gas supply ON.
29. Cycle boiler to ensure proper operation and lighting.
30. Replace front panel.
31. Fill out and affix conversion plate adjacent to rating plate. Complete this step to provide proper identification for customer service or technical support issues.

⚠ CAUTION

WHAT TO DO IF YOU SMELL GAS

- Do not try to light any appliance.
- Do not touch any electrical switch; do not use any phone in your building.
- Immediately call your gas supplier from a neighbor's phone. Follow gas supplier's instructions.
- If you cannot reach your gas supplier, call the fire department.

Table 3 - MAIN BURNER ORIFICES		
INPUT (BTUH)	ORIFICE	QTY.
45,000	47	1
70,000	50	2
96,000	47	2
120,000	49	3
145,000	47	3
170,000	49	4
175,000		
195,000	47	4
245,000	47	5
295,000	47	6

Figure 3 - Gas Valve

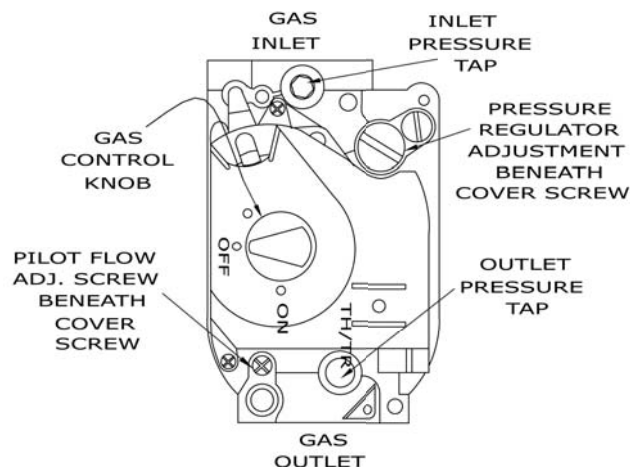

NATURAL GAS TO LP CONVERSION INSTRUCTIONS

Figure 4 - Gas Valve

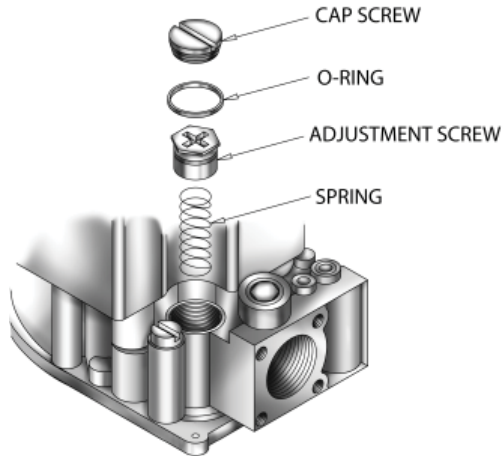

Figure 5 - Burners, Gas Valve, & Manifold

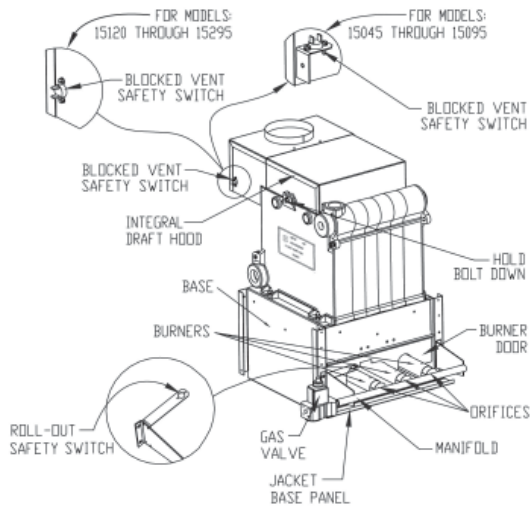
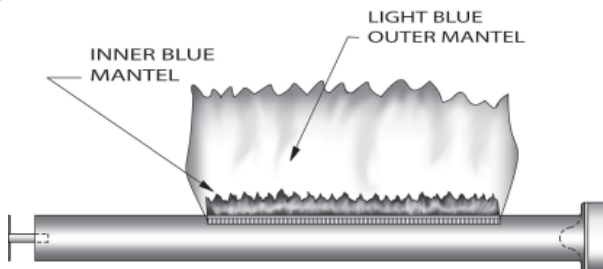

Figure 6 - Burner Mantel



- Thermostat actuates on call for heat, completing circuit to control.
- Completed circuit to control activates circulator. Damper will close end switch inside the damper. This will complete circuit to ignition system and ignition takes place.
- Power is interrupted between control system and ignition system if boiler water temperature exceeds high limit setting on boiler mounted high limit control. Power remains off until boiler water temperature drops below high limit setting. Circulator continues to operate under this condition until thermostat is satisfied.
- Blocked flow of combustion products through boiler venting system causes blocked vent safety switch to shut main burner gas off. If boiler flueway becomes blocked, flame rollout safety switch will shut main burner gas off. See Figure 6. If either condition occurs, do not attempt to place boiler back into operation. Contact qualified service agency.
- Main burner flame should have well defined inner blue mantel with lighter blue outer mantel. See Figure 6.
- Pilot flame should envelop $\frac{3}{8}$ to $\frac{1}{2}$ inch of tip of the pilot thermocouple, ignition/sensing electrode or mercury sensor. See Figure 7.

Checking Gas Input Rate To Boiler



- Adjust gas input to boiler by removing protective cap on pressure regulator and turning screw clockwise  to increase input and counterclockwise  to decrease input.
- Set LP gas manifold pressure at approximately 11.0 inches water column. Manifold pressure is taken at outlet side of gas valve.
- Check for CO₂ and CO levels to assure proper operation.
- Change burner orifices if final manifold pressure varies more than plus or minus 0.3 inches water column from specified pressure.
- Primary air adjustment is not necessary, therefore air shutters are not furnished as standard equipment. Air shutters are available on request where required by local codes or conditions.

Figure 7 - Pilot

