



# Installation Instructions

## TABLE OF CONTENTS

|  | PAGE   |
|--|--------|
| <b>SAFETY CONSIDERATIONS</b> .....               | 2      |
| <b>INSTALLATION RECOMMENDATIONS</b> .....        | 2      |
| <b>INSTALLATION</b> .....                        | 3 - 12 |
| Step 1 - Check Equipment & Jobsite .....         | 3      |
| Step 2 - Install on Solid Pad .....              | 3      |
| Step 3 - Clearance Requirements .....            | 3      |
| Step 4 - Operating Ambient .....                 | 3      |
| Step 5 - Elevate Unit .....                      | 3      |
| Step 6 - Install TXV .....                       | 3 - 4  |
| Step 7 - Check Defrost Thermostat .....          | 5      |
| Step 8 - Make Piping Connections .....           | 5 - 7  |
| Step 9 - Make Electrical Connections .....       | 7 - 8  |
| Step 10 - Compressor Crankcase Heater .....      | 8      |
| Step 11 - Install Electrical Accessories .....   | 8      |
| Step 12 - Start-Up .....                         | 9 - 11 |
| Step 13 - Check Charge .....                     | 12     |
| Step 14 - Final Checks .....                     | 12     |
| <b>CARE AND MAINTENANCE</b> .....                | 12     |
| <b>PURON® REFRIGERANT QUICK REF. GUIDE</b> ..... | 14     |



**Comfort**  
**SERIES**

A05341

**Fig. 1 – 25HCA**

**NOTE:** Read the entire instruction manual before starting the installation.

## SAFETY CONSIDERATIONS

Improper installation, adjustment, alteration, service, maintenance, or use can cause explosion, fire, electrical shock, or other conditions which may cause death, personal injury, or property damage. Consult a qualified installer, service agency, or your distributor or branch for information or assistance. The qualified installer or agency must use factory-authorized kits or accessories when modifying this product. Refer to the individual instructions packaged with the kits or accessories when installing.

Follow all safety codes. Wear safety glasses, protective clothing, and work gloves. Use quenching cloth for brazing operations. Have fire extinguisher available. Read these instructions thoroughly and follow all warnings or cautions included in literature and attached to the unit. Consult local building codes and National Electrical Code (NEC) for special requirements.

Recognize safety information. This is the safety-alert symbol . When you see this symbol on the unit and in instructions or manuals, be alert to the potential for personal injury.

Understand these signal words; DANGER, WARNING, and CAUTION. These words are used with the safety-alert symbol. DANGER identifies the most serious hazards which **will** result in severe personal injury or death.

WARNING signifies hazards which **could** result in personal injury or death. CAUTION is used to identify unsafe practices which **may** result in minor personal injury or product and property damage. NOTE is used to highlight suggestions which **will** result in enhanced installation, reliability, or operation.



## WARNING

### ELECTRICAL SHOCK HAZARD

Failure to follow this warning could result in personal injury or death.

Before installing, modifying, or servicing system, main electrical disconnect switch must be in the OFF position. There may be more than 1 disconnect switch. Lock out and tag switch with a suitable warning label.

25HCA

## INSTALLATION RECOMMENDATIONS

**NOTE:** In some cases noise in the living area has been traced to gas pulsations from improper installation of equipment.

1. Locate unit away from windows, patios, decks, etc. where unit operation sound may disturb customer.
2. Ensure that vapor and liquid tube diameters are appropriate for unit capacity.
3. Run refrigerant tubes as directly as possible by avoiding unnecessary turns and bends.
4. Leave some slack between structure and unit to absorb vibration.
5. When passing refrigerant tubes through the wall, seal opening with RTV or other pliable silicon-based caulk. (See Fig. 2.)
6. Avoid direct tubing contact with water pipes, duct work, floor joists, wall studs, floors, and walls.
7. Do not suspend refrigerant tubing from joists and studs with a rigid wire or strap which comes in direct contact with tubing. (See Fig. 2.)
8. Ensure that tubing insulation is pliable and completely surrounds vapor tube.
9. When necessary, use hanger straps which are 1 in. wide and conform to shape of tubing insulation. (See Fig. 2.)
10. Isolate hanger straps from insulation by using metal sleeves bent to conform to shape of insulation.

**NOTE:** Avoid contact between tubing and structure

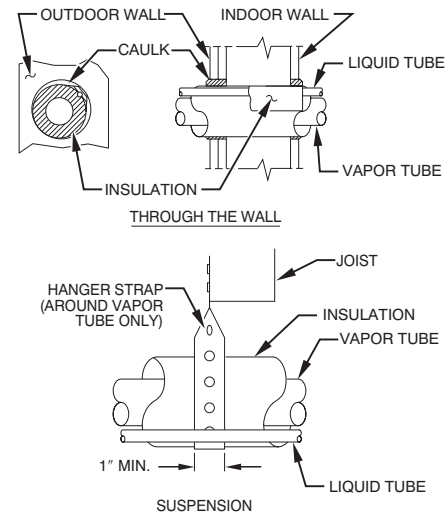

**Fig. 2 – Connecting Tubing Installation**

When outdoor unit is connected to factory-approved indoor unit, outdoor unit contains system refrigerant charge for operation with ARI rated indoor unit when connected by 15 ft. of field-supplied or factory accessory tubing. For proper unit operation, check refrigerant charge using charging information located on control box cover and/or in the Check Charge section of this instruction.

**IMPORTANT:** Maximum liquid-line size is 3/8-in. OD for all residential applications including longline.

**IMPORTANT:** Always install the factory-supplied liquid-line filter drier. If replacing the filter drier, refer to Product Data Digest for appropriate part number. Obtain replacement filter driers from your distributor or sales office.

A94028

## INSTALLATION

### STEP 1 —Check Equipment and Job Site

#### Unpack Unit

Move to final location. Remove carton taking care not to damage unit.

#### Inspect Equipment

File claim with shipping company prior to installation if shipment is damaged or incomplete. Locate unit rating plate on unit corner panel. It contains information needed to properly install unit. Check rating plate to be sure unit matches job specifications.

### STEP 2 —Install on a Solid, Level Mounting Pad

If conditions or local codes require the unit be attached to pad, tie down bolts should be used and fastened through knockouts provided in unit base pan. Refer to unit mounting pattern in Fig. 3 to determine base pan size and knockout hole location.

For hurricane tie downs, contact distributor for details and PE Certification (Professional Engineer), if required.

On rooftop applications, mount on level platform or frame. Place unit above a load-bearing wall and isolate unit and tubing set from structure. Arrange supporting members to adequately support unit and minimize transmission of vibration to building. Consult local codes governing rooftop applications.

Roof mounted units exposed to winds above 5 mph may require wind baffles. Consult the Service Manual - Residential Split System Air Conditioners and Heat Pumps for wind baffle construction.

**NOTE:** Unit must be level to within  $\pm 2^\circ$  ( $\pm 3/8$  in./ft.) per compressor manufacturer specifications.

### STEP 3 —Clearance Requirements

When installing, allow sufficient space for airflow clearance, wiring, refrigerant piping, and service. Allow 30-in. clearance to service end of unit and 48 in. above unit. For proper airflow, a 6-in. clearance on 1 side of unit and 12 in. on all remaining sides must be maintained. Maintain a distance of 24 in. between units. Position so water, snow, or ice from roof or eaves cannot fall directly on unit.

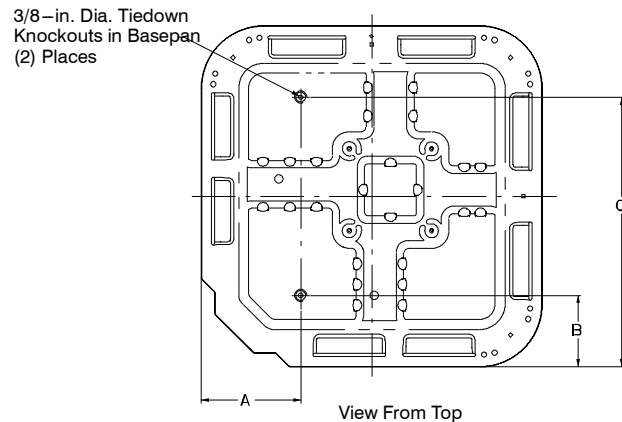

| UNIT BASE PAN DIMENSIONS | TIEDOWN KNOCKOUT LOCATIONS |        |          |
|--------------------------|----------------------------|--------|----------|
|                          | A                          | B      | C        |
| 26 X 26                  | 9-1/8                      | 4-7/16 | 21-1/4   |
| 31-1/2 X 31-1/2          | 9-1/8                      | 6-9/16 | 24-11/16 |
| 35 X 35                  | 9-1/8                      | 6-9/16 | 28-7/16  |

A05177

**Fig. 3 – Tiedown Knockout Requirements**

On rooftop applications, locate unit at least 6 in. above roof surface.

### STEP 4 —Operating Ambient

The minimum outdoor operating ambient in cooling mode is 55°F, and the maximum outdoor operating ambient in cooling mode is 125°F. The maximum outdoor operating ambient in heating mode is 66 °F.

### STEP 5 —Elevate Unit

⚠ **CAUTION**

**UNIT OPERATION HAZARD**

Failure to follow this caution may result in equipment damage or improper operation.

Unit must be kept free of an accumulation of water and/or ice in the basepan.

Elevate unit per local climate and code requirements to provide clearance above estimated snowfall level and ensure adequate drainage of unit. If using accessory support feet, use installation instructions from kit for installation.

⚠ **CAUTION**

**EQUIPMENT DAMAGE HAZARD**

Failure to follow this caution may result in equipment damage or improper operation.

Ensure that unit is located with the supports such that the unit is stable in all circumstances including adverse conditions.

### STEP 6 —Install TXV

**NOTE:** Applies to **non-TXV** indoor units only. If installing a rated and approved indoor coil without a factory installed Puron TXV, remove and replace the fixed orifice or R-22 TXV expansion device with a hard shutoff Puron® TXV.

The thermostatic expansion valve is specifically designed to operate with Puron Refrigerant. Do not use an R-22 TXV. An existing R-22 TXV must be replaced with a factory approved TXV specifically designed for Puron Refrigerant. Refer to Product Data Digest for the appropriate TXV kit number.

⚠ **CAUTION**

**UNIT OPERATION HAZARD**

Failure to follow this caution may result in equipment damage or improper operation.

All indoor coil units must be installed with a hard shutoff Puron TXV metering device.

**IMPORTANT:** If not factory installed, the TXV should be mounted as close to the indoor coil as possible and in a vertical, upright position. Avoid mounting the inlet tube vertically down. Valve is more susceptible to malfunction due to debris if inlet tube is facing down. A factory-approved filter drier must be installed in the liquid line.

25HCA

### Installing TXV in Place of Piston

1. Pump system down to 2 psig and recover refrigerant.
2. Remove hex nut from piston body. Use backup wrench on fan coils.
3. Remove and discard factory-installed piston. Be sure Teflon® seal is in place.
4. Reinstall hex nut. Finger tighten nut plus 1/2 turn.

**NOTE:** If the piston is not removed from the body, TXV will not function properly.



## CAUTION

### EQUIPMENT DAMAGE HAZARD

Failure to follow this caution may result in equipment damage or improper operation.

Use a brazing shield and wrap TXV with wet cloth or use heat sink material.

5. Install TXV on indoor coil liquid line. Sweat swivel adapter to inlet of indoor coil and attach to TXV outlet. Use backup wrench to avoid damage to tubing or valve. Sweat inlet of TXV, marked "IN" to liquid line. Avoid excessive heat which could damage valve.
6. Install vapor elbow with equalizer adapter to suction tube of line set and suction connection to indoor coil. Adapter has a 1/4-in. male connector for attaching equalizer tube.
7. Connect equalizer tube of TXV to 1/4-in. equalizer fitting on vapor line adapter.
8. Attach TXV bulb to horizontal section of suction line using clamps provided. Insulate bulb with field-supplied insulation tape. See Fig. 4 for correct positioning of sensing bulb.
9. Proceed with remainder of unit installation.

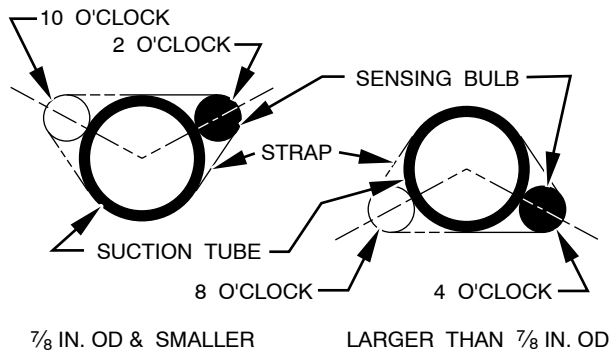

Fig. 4 – Position of Sensing Bulb

A81032

### Replacing TXV on R-22 Indoor Coil

1. Pump system down to 2 psig and recover refrigerant.
2. Remove coil access panel and fitting panel from front of cabinet.
3. Remove TXV support clamp using a 5/16-in. nut driver. Save the clamp.
4. Remove R-22 TXV using a backup wrench on flare connections to prevent damage to tubing.
5. Using wire cutters, cut equalizer tube off flush with vapor tube inside cabinet.
6. Remove bulb from vapor tube inside cabinet.
7. Braze equalizer stub-tube closed. Use protective barrier as necessary to prevent damage to drain pan.

**IMPORTANT:** Route the equalizer tube of Puron TXV through suction line connection opening in fitting panel prior to replacing fitting panel around tubing.

8. Install TXV with 3/8-in. copper tubing through small hole in service panel. Use wrench and backup wrench, to avoid damage to tubing or valve, to attach TXV to distributor.
9. Reinstall TXV support clamp (removed in item 3).
10. Attach TXV bulb to vapor tube inside cabinet, in same location as original was when removed, using supplied bulb clamps (nylon or copper). See Fig. 4 for correct positioning of sensing bulb.
11. Route equalizer tube through suction connection opening (large hole) in fitting panel and install fitting panel in place.
12. Sweat inlet of TXV, marked IN to liquid line. Avoid excessive heat which could damage valve.
13. Install vapor elbow with equalizer adapter to vapor line of line set and vapor connection to indoor coil. Adapter has a 1/4-in. male connector for attaching equalizer tube.
14. Connect equalizer tube of TXV to 1/4-in. equalizer fitting on vapor line adapter. Use backup wrench to prevent damage to equalizer fitting.
15. Proceed with remainder of unit installation.

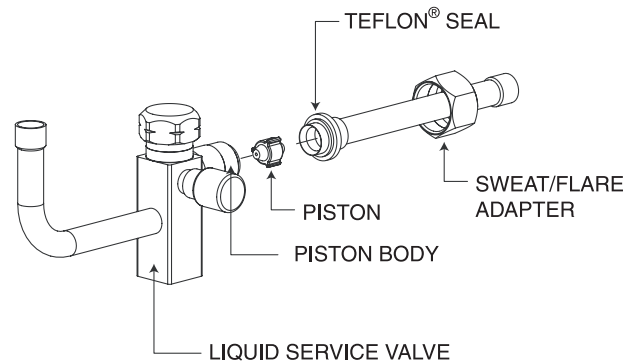
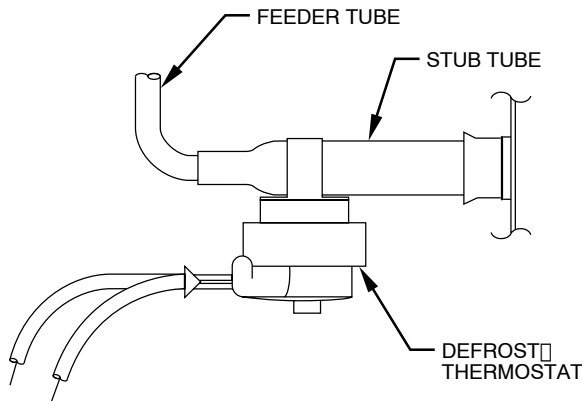

Fig. 5 – Liquid Service Valve with Sweat Adapter Tube

A05226

**STEP 7 —Check Defrost Thermostat**

Check defrost thermostat to ensure it is properly located and securely attached. There is a liquid header with a brass distributor and feeder tube going into outdoor coil. At the end of the one of the feeder tubes, there is a 3/8 in. O.D. stub tube approximately 2 in. long. (See Fig. 6.) The defrost thermostat should be located on stub tube. Note that there is only one stub tube used with liquid header, and on most units it is the bottom circuit.



**Fig. 6 – Defrost Thermostat Location**

A97517

**STEP 8 —Make Piping Connections**

**⚠ WARNING**

**PERSONAL INJURY AND UNIT DAMAGE HAZARD**

Failure to follow this warning could result in personal injury or death.

Relieve pressure and recover all refrigerant before system repair or final unit disposal.

Use all service ports and open all flow-control devices, including solenoid valves.

**⚠ CAUTION**

**UNIT DAMAGE HAZARD**

Failure to follow this caution may result in equipment damage or improper operation.

If ANY refrigerant tubing is buried, provide a 6-in. vertical rise at service valve.

Refrigerant tubing lengths up to 36-in. may be buried without further special consideration. Do not bury lines longer than 36 in.

**⚠ CAUTION**

**UNIT DAMAGE HAZARD**

Failure to follow this caution may result in equipment damage or improper operation.

To prevent damage to unit or service valves, observe the following:

- Use a brazing shield
- Wrap service valves with wet cloth or use a heat sink material.

25HCA

Outdoor units may be connected to indoor section using accessory tubing package or field-supplied refrigerant grade tubing of correct size and condition. For tubing requirements beyond 80 ft., substantial capacity and performance losses can occur. Following the recommendations in the Long Line Guideline for Split-System Air Conditioners and Heat Pumps will reduce these losses. Refer to Table 1 for accessory requirements. Refer to Table 2 for field tubing diameters.

If refrigerant tubes or indoor coil are exposed to atmosphere, they must be evacuated to 500 microns to eliminate contamination and moisture in the system.

**Table 1—Accessory Usage**

| Accessory                                   | REQUIRED FOR LOW-AMBI-ENT APPLICATIONS (Below 55 °F) | REQUIRED FOR LONG LINE APPLICATIONS* (Over 80 ft.) | REQUIRED FOR SEA COAST APPLICATIONS (Within 2 miles) |
|---|--|--|--|
| Crankcase Heater                            | Yes  | Yes  | No   |
| Evaporator Freeze Thermostat                | Yes  | No   | No   |
| Winter Start Control                        | Yes  | No   | No   |
| Accumulator                                 | No   | No   | No   |
| Compressor Start Assist Capacitor and Relay | Yes  | Yes  | No   |
| Motor Master® Control                       | Yes†   | No   | No   |
| Support Feet                                | Recommended  | No   | Recommended  |
| Liquid Line Solenoid Valve                  | Yes  | See Long-Line Application Guideline                | No   |
| Ball Bearing Fan Motor                      | Yes‡   | No   | No   |

\* For Tubing Set lengths between 80 and 200 ft. horizontal or 20 ft. vertical differential (250 ft. Total Equivalent Length), refer to the Long Line Guidelines for Air Conditioners and Heat Pumps using R-22.

† Required for low-ambient controller (full modulation feature) and Motor Master® control only.

**Table 2—Refrigerant Connections and Recommended Liquid and Vapor Tube Diameters (In.)**

| UNIT SIZE       | LIQUID              |               | VAPOR (up to 80 ft.) |                     |
|-----------------|---------------------|---------------|----------------------|---------------------|
|                 | Connection Diameter | Tube Diameter | Connection Diameter  | Rated Tube Diameter |
| <b>018, 024</b> | 3/8                 | 3/8           | 5/8                  | 5/8                 |
| <b>030, 036</b> | 3/8                 | 3/8           | 3/4                  | 3/4                 |
| <b>042, 048</b> | 3/8                 | 3/8           | 7/8                  | 7/8                 |
| <b>060</b>      | 3/8                 | 3/8           | 7/8                  | 1-1/8               |

**Notes:**

1. Tube diameters are for total equivalent lengths up to 80 ft.
2. Do not apply capillary tube or fixed orifice indoor coils to these units.
- \* For Tubing Set lengths between 80 and 200 ft. horizontal or 20 ft. vertical differential (250 ft. Total Equivalent Length), refer to the Longline Guideline— Air Conditioners and Heat Pumps using R-22

**Outdoor Unit Connected to Factory-Approved Indoor Unit**

These outdoor units are carefully evaluated and listed with specific indoor coils for proper system performance.

**IMPORTANT:** Do not apply indoor coils which are not factory approved to these units.

**Install Adapter Tube**

1. Remove plastic retainer holding outdoor piston in liquid service valve.
2. Check outdoor piston size with matching number listed on unit rating plate.
3. Locate plastic bag taped to unit containing adapter tube.
4. Remove Teflon® washer from bag and install on open end of liquid service valve. (See Fig. 5.)
5. Remove adapter tube from bag and connect threaded nut to liquid service valve. Tighten nut finger-tight and then with wrench an additional 1/2 turn (15 ft-lb). **DO NOT OVER TIGHTEN!**

**Refrigerant Tubing and Sweat Connections**

Connect vapor tube to fitting on outdoor unit vapor service valves (see Table 2). Connect liquid tubing to adapter tube on liquid service valve. Use refrigerant grade tubing.

**Install Liquid Line Filter Drier Indoor**

Refer to Fig. 7 and install filter drier as follows:

1. Braze 5 in. liquid tube to the indoor coil.
2. Wrap filter drier with damp cloth.
3. Braze filter drier to 5 in. long liquid tube from step 1.
4. Connect and braze liquid refrigerant tube to the filter drier.

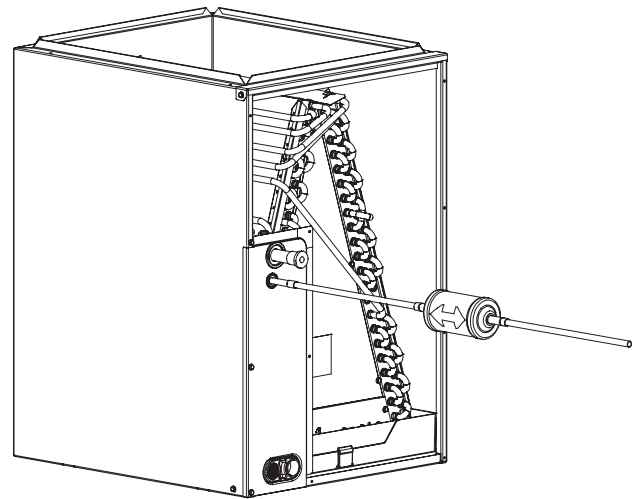

**Fig. 7 – Liquid Line Filter Drier**

A05227

**Leak Testing**

Leak test all joints indoors, outdoors, and refrigerant tubing.

**Evacuate Refrigerant Tubing and Indoor Coil**

**⚠ CAUTION**

**UNIT DAMAGE HAZARD**

Failure to follow this caution may result in equipment damage or improper operation.

Service valves must be wrapped in a heat-sinking material such as a wet cloth.

**⚠ CAUTION**

**UNIT DAMAGE HAZARD**

Failure to follow this caution may result in equipment damage or improper operation.

Installation of filter drier in liquid line is required.

**⚠ CAUTION**

**UNIT DAMAGE HAZARD**

Failure to follow this caution may result in equipment damage or improper operation.

Never use the system compressor as a vacuum pump.

Refrigerant tubes and indoor coil should be evacuated using the recommended the recommended deep vacuum method of 500 microns. The alternate triple evacuation method may be used if the procedure outlined below is followed.

**IMPORTANT:** Always break a vacuum with dry nitrogen.

**25HCA**

**Deep Vacuum Method**

The deep vacuum method requires a vacuum pump capable of pulling a vacuum of 500 microns and a vacuum gage capable of accurately measuring this vacuum depth. The deep vacuum method is the most positive way of assuring a system is free of air and liquid water. See Fig. 8.

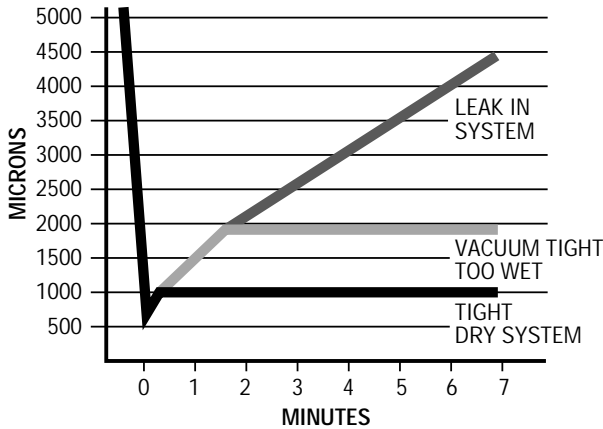

**Fig. 8 – Deep Vacuum Graph**

A95424

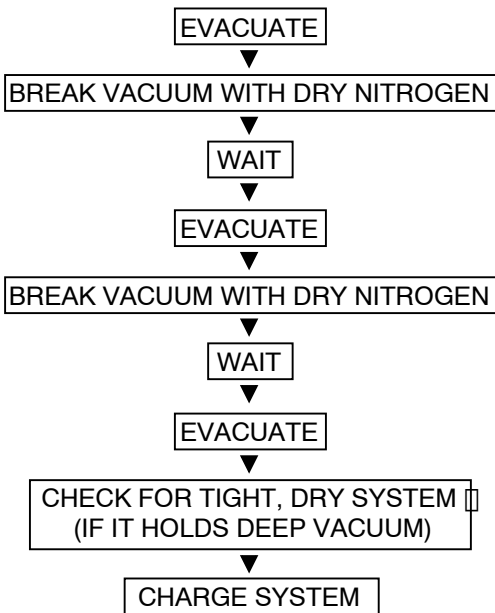

**Fig. 9 – Triple Evacuation Method**

A95425

**Triple Evacuation Method**

The triple evacuation method should only be used when vacuum pump is only capable of pumping down to 28 in. of mercury vacuum, and system does not contain any liquid water. Refer to Fig. 9 and proceed as follows:

1. Pump system down to 28 in. of mercury and allow pump to continue operating for an additional 15 minutes.
2. Close service valves and shut off vacuum pump.
3. Connect a nitrogen cylinder and regulator to system and open until system pressure is 2 psig.
4. Close service valve and allow system to stand for 1 hour. During this time, dry nitrogen will be able to diffuse throughout the system absorbing moisture.
5. Repeat this procedure as indicated by Fig. 9. System will then be free of any contaminants and water vapor.

**Final Tubing Check**

**IMPORTANT:** Check to be certain factory tubing on both indoor and outdoor unit has not shifted during shipment. Ensure tubes are not rubbing against each other or any sheet metal. Pay close attention to feeder tubes, making sure wire ties on feeder tubes are secure and tight.

**STEP 9 —Make Electrical Connections**

**⚠ WARNING**

**ELECTRICAL SHOCK HAZARD**

Failure to follow this warning could result in personal injury or death.

Do not supply power to unit with compressor terminal box cover removed.

Be sure field wiring complies with local and national fire, safety, and electrical codes, and voltage to system is within limits shown on unit rating plate. Contact local power company for correction of improper voltage. See unit rating plate for recommended circuit protection device.

**NOTE:** Operation of unit on improper line voltage constitutes abuse and could affect unit reliability. See unit rating plate. Do not install system where voltage may fluctuate above or below permissible limits.

**NOTE:** Use copper wire only between disconnect switch and unit.

**NOTE:** Install branch circuit disconnect of adequate size per NEC to handle unit starting current. Locate disconnect within sight from and readily accessible from unit, per Section 440-14 of NEC.

**Route Ground and Power Wires**

Remove access panel to gain access to unit wiring. Extend wires from disconnect through power wiring hole provided and into unit control box.

**⚠ WARNING**

**ELECTRICAL SHOCK HAZARD**

Failure to follow this warning could result in personal injury or death.

The unit cabinet must have an uninterrupted or unbroken ground to minimize personal injury if an electrical fault should occur.

The ground may consist of electrical wire or metal conduit when installed in accordance with existing electrical codes.

**25HCA**

**Connect Ground and Power Wires**

Connect ground wire to ground connection in control box for safety. Connect power wiring to contactor as shown in Fig. 10.

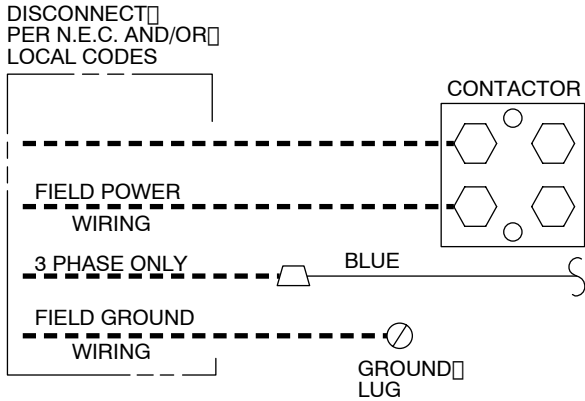

**Fig. 10 – Line Connections**

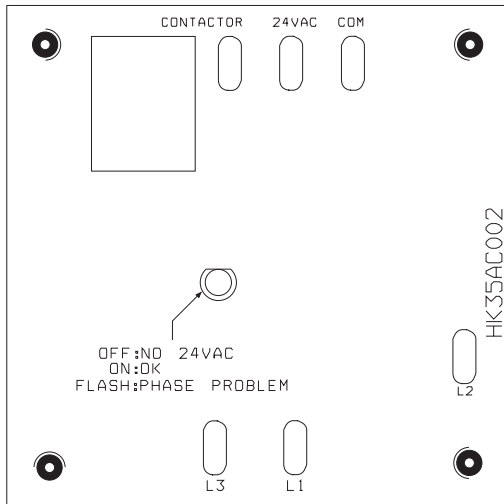

**Fig. 11 – 3-Phase Monitor Control  
(Applies to 3-Phase Units Only)**

**Table 3—3-Phase Monitor LED Indicators**

| LED      | STATUS                           |
|----------|----------------------------------|
| OFF      | No call for compressor operation |
| FLASHING | Reversed phase                   |
| ON       | Normal                           |

**CAUTION**

**UNIT DAMAGE HAZARD**

Failure to follow this caution may result in equipment damage or improper operation.

Ensure compressor rotation is correct.

- 3-phase scroll compressors are rotation sensitive.
- A flash LED on phase monitor indicates reverse rotation. (See Fig. 11 and Table 3)

This will not allow contractor to be energized.

- Disconnect power to unit and interchange 2 field-wiring leads on unit contactor.

**Connect Control Wiring**

Route 24v control wires through control wiring grommet and connect leads to control wiring. See Thermostat Installation Instructions for wiring specific unit combinations. (See Fig. 12.)

Use No. 18 AWG color-coded, insulated (35°C minimum) wire. If thermostat is located more than 100 ft. from unit, as measured along the control voltage wires, use No. 16 AWG color-coded wire to avoid excessive voltage drop.

All wiring must be NEC Class 1 and must be separated from incoming power leads.

Use furnace transformer, fan coil transformer, or accessory transformer for control power, 24v/40va minimum.

**NOTE:** Use of available 24v accessories may exceed the minimum 40va power requirement. Determine total transformer loading and increase the transformer capacity or split the load with an accessory transformer as required.

**Final Wiring Check**

**IMPORTANT:** Check factory wiring and field wire connections to ensure terminations are secured properly. Check wire routing to ensure wires are not in contact with tubing, sheet metal, etc.

**STEP 10 —Compressor Crankcase Heater**

When equipped with a crankcase heater, furnish power to heater a minimum of 24 hr before starting unit. To furnish power to heater only, set thermostat to OFF and close electrical disconnect to outdoor unit.

A crankcase heater is required if refrigerant tubing is longer than 80 ft. Refer to the Long Line Guideline-Residential Split-System Air Conditioners and Heat Pumps.

**STEP 11 —Install Electrical Accessories**

Refer to the individual installation instructions packaged with kits or accessories when installing.



**⚠ CAUTION**

**UNIT OPERATION AND SAFETY HAZARD**

Failure to follow this caution may result in minor personal injury, equipment damage or improper operation.

To prevent compressor damage or personal injury, observe the following:

- Do not overcharge system with refrigerant.
- Do not operate unit in a vacuum or at negative pressure.
- Do not disable low pressure switch in scroll compressor applications.
- Dome temperatures may be hot.
- In 3 phase applications, incorrect phasing will cause reverse rotation, resulting in elevated noise levels, equalized pressures and reduced current draw. Correct by reversing power connection L1 and L2 on contactor.

**⚠ CAUTION**

**PERSONAL INJURY HAZARD**

Failure to follow this caution may result in personal injury.

Wear safety glasses, protective clothing, and gloves when handling refrigerant and observe the following:

- Front seating service valves are equipped with Schrader valves.

**⚠ CAUTION**

**ENVIRONMENTAL HAZARD**

Failure to follow this caution may result in environmental damage.

Federal regulations require that you do not vent refrigerant to the atmosphere. Recover during system repair or final unit disposal.

**Follow these steps to properly start up system:**

1. After system is evacuated, fully open liquid and vapor service valves.
2. Unit is shipped with valve stem(s) closed and caps installed. Replace stem caps after system is opened to refrigerant flow (back seated). Replace caps finger-tight and tighten with wrench an additional 1/12 turn.
3. Close electrical disconnects to energize system.
4. Set room thermostat at desired temperature. Be sure set point is below indoor ambient temperature.
5. Set room thermostat to HEAT or COOL and fan control to ON or AUTO mode, as desired. Operate unit for 15 minutes. Check system refrigerant charge.

**⚠ CAUTION**

**UNIT OPERATION AND SAFETY HAZARD**

Failure to follow this caution may result in minor personal injury, equipment damage or improper operation.

To prevent compressor damage or personal injury, observe the following:

- Do not overcharge system with refrigerant.
- Do not operate unit in a vacuum or at negative pressure.
- Do not disable low pressure switch in scroll compressor applications.
- Dome temperatures may be hot.
- In 3 phase applications, incorrect phasing will cause reverse rotation, resulting in elevated noise levels, equalized pressures and reduced current draw. Correct by reversing power connection L1 and L2 on contactor.

25HCA

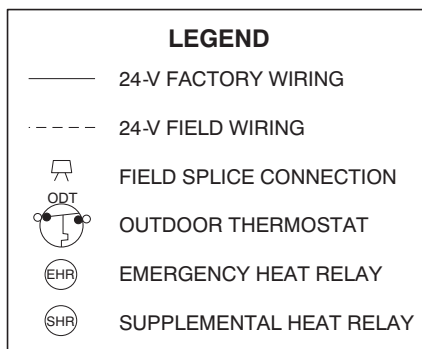
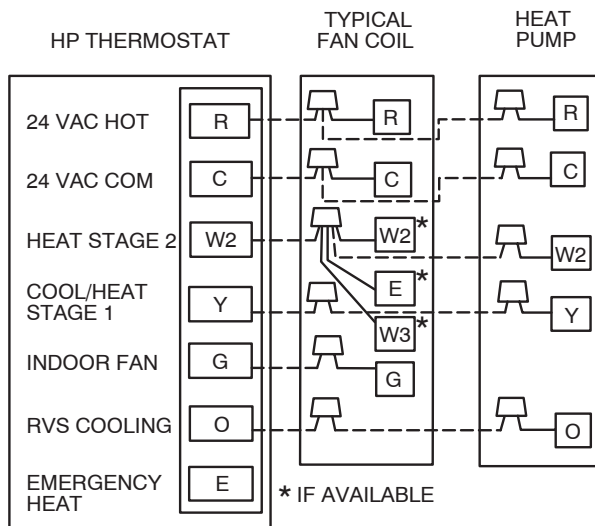

**Fig. 12 – Generic Wiring Diagrams**  
 (See Thermostat Installation Instructions for specific unit combinations)

A02325 / A97413

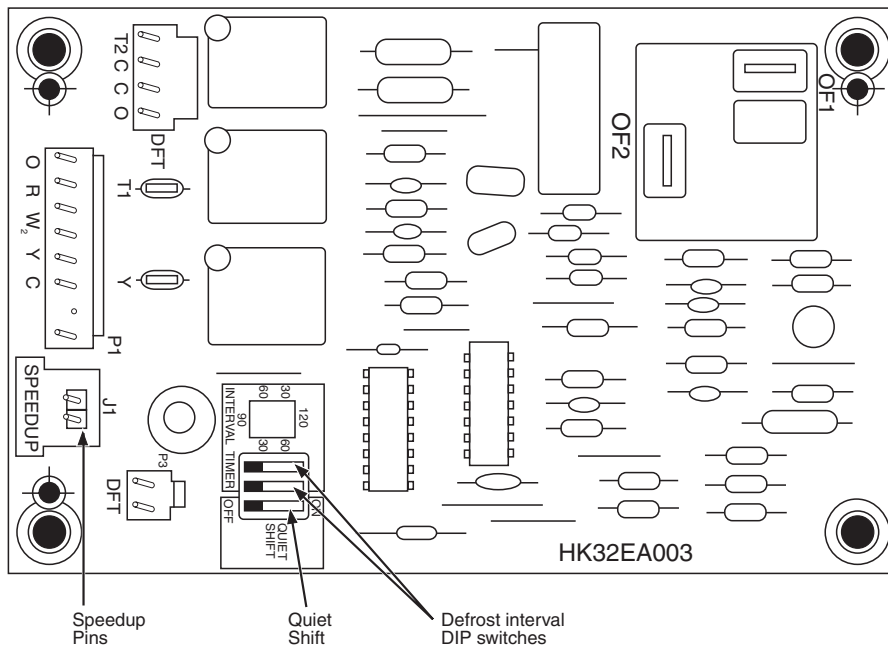

**Fig. 13 – Defrost Control**

A05378

### **Sequence of Operation**

**NOTE:** Defrost control board is equipped with 5 minute lockout timer that is initiated upon any interruption of power.

Turn on power to indoor and outdoor units. Transformer is energized.

#### **Cooling**

On a call for cooling, thermostat makes circuits R-O, R-Y, and R-G. Circuit R-O energizes reversing valve, switching it to cooling position. Circuit R-Y sends low voltage through the safeties and energizes the T1 terminal on the circuit board. If the compressor has been off for 5 minutes, or power has not been cycled for 5 minutes, the OF2 relay and T2 terminal will energize. This will close the contactor, and start the outdoor fan motor and compressor.

When the cycle is complete, R-Y is turned off, stopping the compressor and outdoor fan. The 5 minute time guard begins counting. Compressor will not come on again until this delay expires. In the event of a power interruption, the time guard will not allow another cycle for 5 minutes.

**NOTE:** If the indoor blower off delay is enabled, it will run up to an additional 90 seconds to increase system efficiency.

#### **Heating**

On a call for heating, thermostat makes circuits R-Y and R-G. Circuit R-Y sends low voltage through the safeties and energizes the T1 terminal on the circuit board. T1 energizes the defrost logic circuit. If the compressor has been off for 5 minutes, or power has not been cycled for 5 minutes, the OF2 relay and T2 terminal will energize. This will close the contactor, start the outdoor fan motor and compressor.

When the cycle is complete, R-Y is turned off, stopping the compressor and outdoor fan. The 5 minute time guard begins counting. Compressor will not come on again until this time delay expires. In the event of a power interruption, the time guard will not allow another cycle for 5 minutes.

### **Quiet Shift**

Quiet shift is a field selectable defrost mode (factory set to OFF), which will eliminate occasional noise that could be heard at the start of defrost cycle and restarting of heating cycle. It is selected by placing DIP switch 3 on defrost board (see Fig. 13) in the ON position.

When Quiet Shift switch is placed in ON position, and a defrost is initiated, the following sequence of operation will occur. Reversing valve will energize, compressor will turn off for 30 seconds, and then turn back on to complete defrost. At the start of heating after conclusion of defrost, reversing valve will de-energize, compressor will turn off for another 30 seconds, and the fan will turn off for 40 seconds, before starting in the heating mode.

#### **Defrost**

The defrost control is a time/temperature control which has field selectable settings of 30, 60, 90, or 120 minutes, factory set to 90 minutes. These settings represent the amount of time that must pass after closure of the defrost thermostat before the defrost sequence begins.

The defrost thermostat senses coil temperature throughout the heating cycle. When the coil temperature reaches the defrost thermostat setting of approximately 32 degrees F, it will close, which energizes the DFT terminal and begins the defrost timing sequence. When the DFT has been energized for the selected time, the defrost cycle begins.

Defrost cycle is terminated when defrost thermostat opens, or automatically after 10 minutes.

#### **Defrost Speedup**

To initiate a forced defrost, speedup pins (J1) must be shorted with a flat head screwdriver for 5 seconds and **RELEASED**. If the defrost thermostat is open, a short defrost cycle will be observed (actual length depends on Quiet Shift switch position). When Quiet Shift is off, only a short 30 second defrost cycle is observed. With Quiet Shift ON, the speedup sequence is one minute; 30 second compressor off period followed by 30 seconds of defrost with compressor operation. When returning to heating mode, the compressor will turn off for an additional 30 seconds and the fan for 40 seconds.

If the defrost thermostat is closed, a complete defrost cycle is initiated. If the Quiet Shift switch is turned on, the compressor will be turned off for two 30 second intervals as explained previously.

**STEP 13 —Check Charge**

Factory charge and charging method are shown on unit rating plate. To check charge in cooling mode, refer to Cooling Only Procedure. To check charge in heating mode, refer to Heating Check Chart Procedure.

With unit operating, charge Puron refrigerant units with liquid using a commercial type metering device in manifold hose. Charge refrigerant into suction line. Check cylinder label for correct position to allow liquid flow.

**Cooling Only Procedure**

**NOTE:** If subcooling charging conditions are not favorable, charge must be weighed in accordance with unit rating plate,  $\pm 0.6$  oz./ft. of 3/8 in. liquid line above or below 15 ft., respectively. Favorable conditions fall within the ranges given on the charging chart on the outdoor unit plate.

**EXAMPLE:**

To calculate additional charge required for a 25–ft. line set:

25 ft. – 15 ft. = 10 ft. X 0.6 oz./ft. = 6 oz. of additional charge.

Units installed with cooling mode TXV require charging with the subcooling method.

1. Operate unit a minimum of 10 minutes before checking charge.
2. Measure liquid service valve pressure by attaching an accurate gage to service port.
3. Measure liquid line temperature by attaching an accurate thermistor type or electronic thermometer to liquid line near outdoor coil.
4. Refer to unit rating plate for required subcooling temperature.
5. Refer to Table 4. Find the point where required subcooling temperature intersects measured liquid service valve pressure.
6. To obtain required subcooling temperature at a specific liquid line pressure, add refrigerant if liquid line temperature is higher than indicated or reclaim refrigerant if temperature is lower. Allow a tolerance of  $\pm 3^{\circ}\text{F}$ .

**Heating Check Chart Procedure**

To check system operation during heating cycle, refer to the Heating Check Chart on outdoor unit. This chart indicates whether a correct relationship exists between system operating pressure and air temperature entering indoor and outdoor units. If pressure and temperature do not match on chart, system refrigerant charge may not be correct. Do not use chart to adjust refrigerant charge.

**NOTE:** In heating mode, check refrigerant charge only when pressures are stable. If in doubt, remove charge and weigh in correct refrigerant charge.

**NOTE:** When charging is necessary during heating season, charge must be weight in accordance with unit rating plate  $\pm 0.6$  oz./ft. of 3/8 in. liquid line above or below 15 ft., respectively.

**EXAMPLE:**

To calculate additional charge required for a 25–ft. line set:

25 ft. – 15 ft. = 10 ft. X 0.6 oz./ft. = 6 oz. of additional charge.

**STEP 14 —Final Checks**

**IMPORTANT:** Before leaving job, be sure to do the following:

1. Ensure that all wiring is routed away from tubing and sheet metal edges to prevent rub-through or wire pinching.
2. Ensure that all wiring and tubing is secure in unit before adding panels and covers. Securely fasten all panels and covers.
3. Tighten service valve stem caps to 1/12–turn past finger tight.
4. Leave Users Manual with owner. Explain system operation and periodic maintenance requirements outlined in manual.
5. Fill out Dealer Installation Checklist and place in customer file.

**CARE AND MAINTENANCE**

For continuing high performance and to minimize possible equipment failure, periodic maintenance must be performed on this equipment.

Frequency of maintenance may vary depending upon geographic areas, such as coastal applications. See Users Manual for information.

Table 4—Required Liquid-Line Temperature

| Liquid Pressure at Service Valve (PSIG) | Required Subcooling Temperature (°F) |     |     |     |
|---|--------------------------------------|-----|-----|-----|
|   | 5                                    | 10  | 15  | 20  |
| 174                                     | 56                                   | 51  | 46  | 41  |
| 181                                     | 58                                   | 53  | 48  | 43  |
| 188                                     | 61                                   | 56  | 51  | 46  |
| 195                                     | 63                                   | 58  | 53  | 48  |
| 202                                     | 65                                   | 60  | 55  | 50  |
| 209                                     | 67                                   | 62  | 57  | 52  |
| 216                                     | 69                                   | 64  | 59  | 54  |
| 223                                     | 71                                   | 66  | 61  | 56  |
| 230                                     | 73                                   | 68  | 63  | 58  |
| 237                                     | 75                                   | 70  | 65  | 60  |
| 244                                     | 77                                   | 72  | 67  | 62  |
| 251                                     | 79                                   | 74  | 69  | 64  |
| 258                                     | 81                                   | 76  | 71  | 66  |
| 265                                     | 82                                   | 77  | 72  | 67  |
| 272                                     | 84                                   | 79  | 74  | 69  |
| 279                                     | 86                                   | 81  | 76  | 71  |
| 286                                     | 88                                   | 83  | 78  | 73  |
| 293                                     | 89                                   | 84  | 79  | 74  |
| 300                                     | 91                                   | 86  | 81  | 76  |
| 307                                     | 93                                   | 88  | 83  | 78  |
| 314                                     | 94                                   | 89  | 84  | 79  |
| 321                                     | 96                                   | 91  | 86  | 81  |
| 328                                     | 97                                   | 92  | 87  | 82  |
| 335                                     | 99                                   | 94  | 89  | 84  |
| 342                                     | 100                                  | 95  | 90  | 85  |
| 349                                     | 102                                  | 97  | 92  | 87  |
| 356                                     | 103                                  | 98  | 93  | 88  |
| 363                                     | 105                                  | 100 | 95  | 90  |
| 370                                     | 106                                  | 101 | 96  | 91  |
| 377                                     | 107                                  | 102 | 97  | 92  |
| 384                                     | 109                                  | 104 | 99  | 94  |
| 391                                     | 110                                  | 105 | 100 | 95  |
| 398                                     | 112                                  | 107 | 102 | 97  |
| 405                                     | 113                                  | 108 | 103 | 98  |
| 412                                     | 114                                  | 109 | 104 | 99  |
| 419                                     | 115                                  | 110 | 105 | 100 |
| 426                                     | 117                                  | 112 | 107 | 102 |
| 433                                     | 118                                  | 113 | 108 | 103 |
| 440                                     | 119                                  | 114 | 109 | 104 |
| 447                                     | 120                                  | 115 | 110 | 105 |
| 454                                     | 122                                  | 117 | 112 | 107 |
| 461                                     | 123                                  | 118 | 113 | 108 |
| 468                                     | 124                                  | 119 | 114 | 109 |
| 475                                     | 125                                  | 120 | 115 | 110 |
| 482                                     | 126                                  | 121 | 116 | 111 |

| Liquid Pressure at Service Valve (PSIG) | Required Subcooling Temperature (°F) |     |     |     |
|---|--------------------------------------|-----|-----|-----|
|   | 5                                    | 10  | 15  | 20  |
| 489                                     | 127                                  | 122 | 117 | 112 |
| 496                                     | 129                                  | 124 | 119 | 114 |
| 503                                     | 130                                  | 125 | 120 | 115 |
| 510                                     | 131                                  | 126 | 121 | 116 |
| 517                                     | 132                                  | 127 | 122 | 117 |
| 524                                     | 133                                  | 128 | 123 | 118 |
| 531                                     | 134                                  | 129 | 124 | 119 |
| 538                                     | 135                                  | 130 | 125 | 120 |
| 545                                     | 136                                  | 131 | 126 | 121 |
| 552                                     | 137                                  | 132 | 127 | 122 |
| 559                                     | 138                                  | 133 | 128 | 123 |
| 566                                     | 139                                  | 134 | 129 | 124 |
| 573                                     | 140                                  | 135 | 130 | 125 |
| 580                                     | 141                                  | 136 | 131 | 126 |
| 587                                     | 142                                  | 137 | 132 | 127 |
| 594                                     | 143                                  | 138 | 133 | 128 |
| 601                                     | 144                                  | 139 | 134 | 129 |
| 608                                     | 145                                  | 140 | 135 | 130 |

25HCA

## PURON® (R-410A) REFRIGERANT QUICK REFERENCE GUIDE

- Puron refrigerant operates at 50–70 percent higher pressures than R–22. Be sure that servicing equipment and replacement components are designed to operate with Puron refrigerant.
- Puron refrigerant cylinders are rose colored.
- Recovery cylinder service pressure rating must be 400 psig, DOT 4BA400 or DOT BW400.
- Puron refrigerant systems should be charged with liquid refrigerant. Use a commercial type metering device in the manifold hose when charging into suction line with compressor operating
- Manifold sets should be 700 psig high side and 180 psig low side with 550 psig low–side retard.
- Use hoses with 700 psig service pressure rating.
- Leak detectors should be designed to detect HFC refrigerant.
- Puron refrigerant, as with other HFCs, is only compatible with POE oils.
- Vacuum pumps will not remove moisture from oil.
- Do not use liquid–line filter driers with rated working pressures less than 600 psig.
- Do not leave Puron suction line filter driers in line longer than 72 hours.
- Do not install a suction–line filter drier in liquid line.
- POE oils absorb moisture rapidly. Do not expose oil to atmosphere.
- POE oils may cause damage to certain plastics and roofing materials.
- Wrap all filter driers and service valves with wet cloth when brazing.
- A factory approved liquid–line filter drier is required on every unit.
- Do NOT use an R–22 TXV.
- If indoor unit is equipped with an R–22 TXV or piston metering device, it must be changed to a hard shutoff Puron TXV.
- Never open system to atmosphere while it is under a vacuum.
- When system must be opened for service, recover refrigerant, evacuate then break vacuum with dry nitrogen and replace filter driers. Evacuate to 500 microns prior to recharging.
- Do not vent Puron refrigerant into the atmosphere.
- Do not use capillary tube coils.
- Observe all **warnings, cautions, and bold** text.
- All indoor coils must be installed with a hard shutoff Puron TXV metering device.