



# Installation Instructions

Part No. 30GX-900---048,  
(60 Hz — 115-v Control)

Part No. 30GX-900---049  
(50 or 60 Hz — 230-v Control)

## CONTENTS

	Page
<b>SAFETY CONSIDERATIONS</b> .....	1
<b>INTRODUCTION</b> .....	1
<b>INSTALLATION</b> .....	1-8
<b>Step 1 — Examine Package Contents</b> .....	1
<b>Step 2 — Install Piping</b> .....	2
• REMOVE MINIMUM LOAD PORT PLUGS AND INSTALL FITTINGS	
• INSTALL PIPING	
• INSTALL BALL AND SOLENOID VALVES	
• CONNECT PIPING	
• 30GXN,R UNITS ONLY	
<b>Step 3 — Dehydrate and Recharge Circuit</b> .....	3
<b>Step 4 — Install Control Wiring</b> .....	3
• 30HX UNITS	
• 30GXN,R UNITS	
• ALL UNITS	
<b>Step 5 — Configure Unit for Minimum   Load Control</b> .....	8
<b>Step 6 — Test Minimum Load Relay   Outputs</b> .....	8
<b>Step 7 — Adjust Setting of Minimum   Load Ball Valve</b> .....	8

## SAFETY CONSIDERATIONS

Installing, starting up, and servicing air-conditioning equipment can be hazardous due to system pressures, electrical components, and equipment location.

Only trained, qualified installers and service technicians should install, start up, and service this equipment.

When working on air-conditioning equipment, observe precautions in the literature and on tags, stickers, and labels attached to the equipment.

Follow all safety codes. Wear safety glasses and work gloves. Use care in handling equipment.

### **WARNING**

Be sure power to equipment is shut off before performing maintenance or service.

**IMPORTANT:** When removing refrigerant, use an approved refrigerant recovery device. Do not vent refrigerant into the atmosphere.

## INTRODUCTION

The minimum load control accessory allows 30HX and 30GXN,R chillers to have their capacities decreased below the standard fully unloaded condition. The accessory provides more precise control of leaving fluid temperature during light load conditions.

The 30GXN,R and 30HX chillers have a dual-circuit design. Each minimum load control accessory package contains the items required for both circuits. Because of an automatic lead/lag feature on the chillers, the accessory should be installed on both circuits.

## INSTALLATION

**Step 1 — Examine Package Contents** — Package includes solenoid valves, ball valves, O-ring seal fittings, and instructions. Examine each item. If any part is damaged or missing, file a claim immediately with the shipper and notify your Carrier representative. See Table 1 for accessory package contents and field-supplied material.

**Table 1 — Accessory Package Contents and Field-Supplied Material**

ACCESSORY PACKAGE COMPONENTS	ACCESSORY PART NUMBER	
	30GX-900---048	30GX-900---049
Solenoid Valve	(2) EF23JX212	(2) EF23JX231
Ball Valve	(2) EP71BA201	(2) EP71BA201
O-Ring Seal Fitting	(4) 30GX503492	(4) 30GX503492
Tube Assembly	(2) 30GX503487	(2) 30GX503457
Tube Assembly (Condenser Oil Separator)	(2) 30HX402343	(2) 30HX402343

### FIELD SUPPLIED MATERIAL — REQUIRED PARTS (Ordered Separately)

<sup>5</sup> / <sub>8</sub> -in. OD Copper Tubing, Wiring, Conduit, Thread Sealant, Electrical Supplies	Field Supplied
---	----------------

## Step 2 — Install Piping

### ⚠ WARNING

Shut off all power to the unit, then lock out and safety-tag all disconnects before proceeding with installation.

### ⚠ WARNING

Remove refrigerant charge from circuits using an approved refrigerant recovery device before proceeding with installation.

NOTE: The units have 2 circuits. Perform all of the following piping installation procedures on both A and B circuits.

**REMOVE MINIMUM LOAD PORT PLUGS AND INSTALL FITTINGS** — Plugs must be removed from these ports and replaced with O-ring seal fittings. Note that plugs were factory-installed with Loctitet 554 or equivalent refrigerant-compatible sealant. Fittings should be installed with similar sealant on threads.

**30GXN,R** — Cut plug end off of minimum load port braze nipple on discharge line, located between oil separator and condenser. Remove plug from minimum load port on cooler shell. See Fig. 1. Using thread sealant, install O-ring seal fitting in minimum load port on cooler. Port on nipple in discharge line is reserved for a brazed connection.

**30HX** — Remove plugs from minimum load ports on the cooler shell and the condenser shell (30HXC) or oil separator (30HXA). See Fig. 2. Using thread sealant, install O-ring seal fittings in minimum load ports.

**INSTALL PIPING** — On 30GXN,R units, carefully thread the cooler tube assemblies (P/N 30GX503487) on the O-ring seal fittings installed in the cooler port. Do not tighten. Install field-supplied  $\frac{5}{8}$ -in. OD copper tubing between the tube assembly and the brazed nipple on the discharge line.

On 30HX units, carefully thread the cooler tube assemblies (P/N 30GX503487) and the condenser oil separator tube assembly (P/N 30HX402343) on the O-ring seal fittings installed in the cooler and condenser/oil separator ports. Do not tighten. Install field-supplied  $\frac{5}{8}$ -in. OD copper tubing between the tube assemblies on the cooler shell and condenser (30HXC) or oil separator (30HXA).

**INSTALL BALL AND SOLENOID VALVES** — Using good piping practice, braze ball valve and solenoid valve into  $\frac{5}{8}$ -in. minimum load piping. Fig. 2 shows a typical 30HX installation and Fig. 3A and 3B show a typical 30GXN,R installation, including valve locations and orientation. Ensure that ball valve is fully open, and that both the ball and solenoid valve are protected from excess heat during brazing process. Wrap wet cloths around valve bodies and tube assembly locking nuts during brazing to prevent damage to the valves and O-rings from heat.

**CONNECT PIPING** — Lubricate O-rings with a light coating of polyalphaolefin lubricant suitable for R-134a systems. Thread tube assembly nuts onto the O-ring seal fittings until they are finger-tight. Lightly snug the nut with a wrench; **DO NOT OVER TIGHTEN**. You should be able to feel the O-ring compress on the last  $\frac{1}{4}$ -turn.

**IMPORTANT: DO NOT** over tighten the O-ring seal nut. Damage will occur to the seal, resulting in leaks.

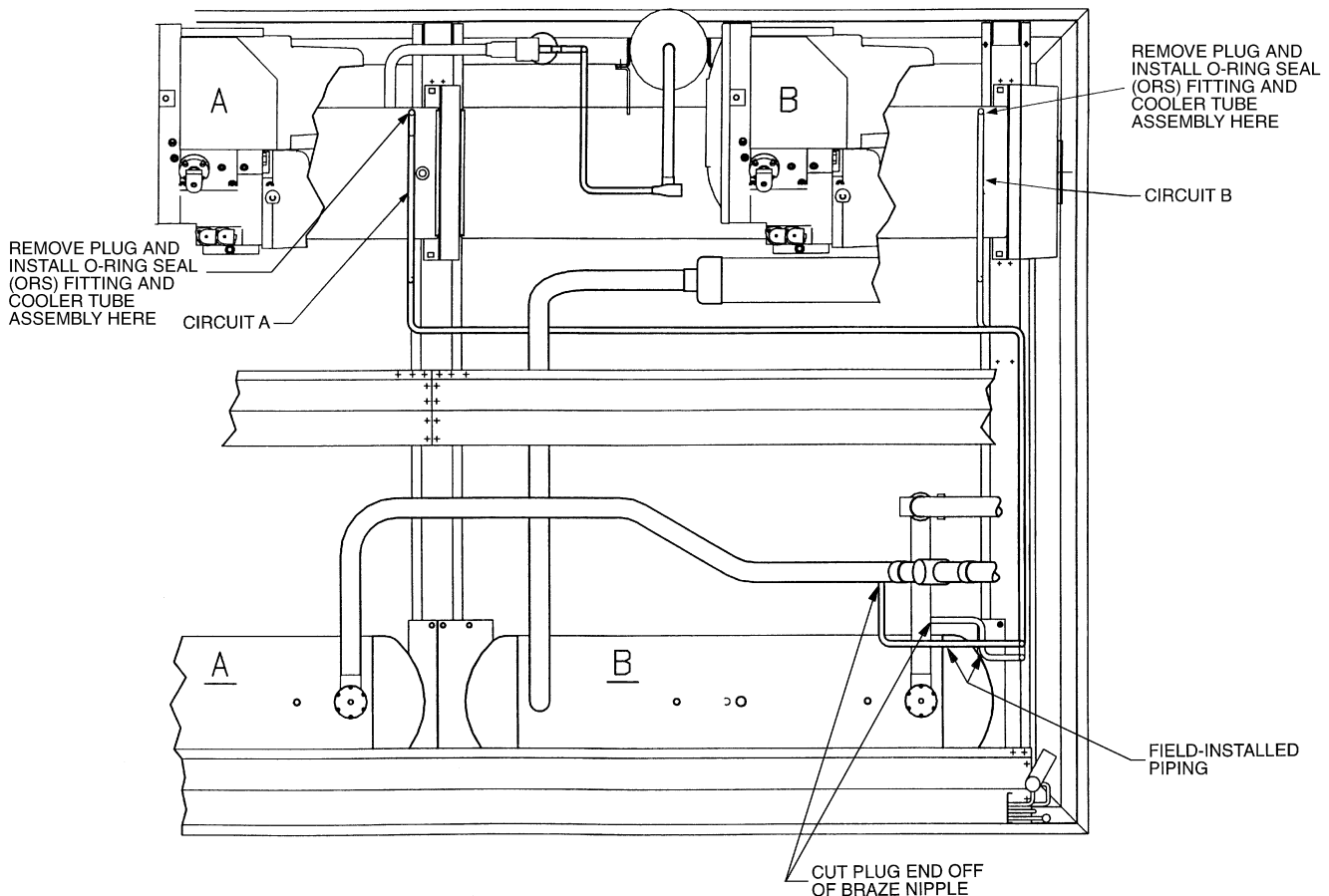
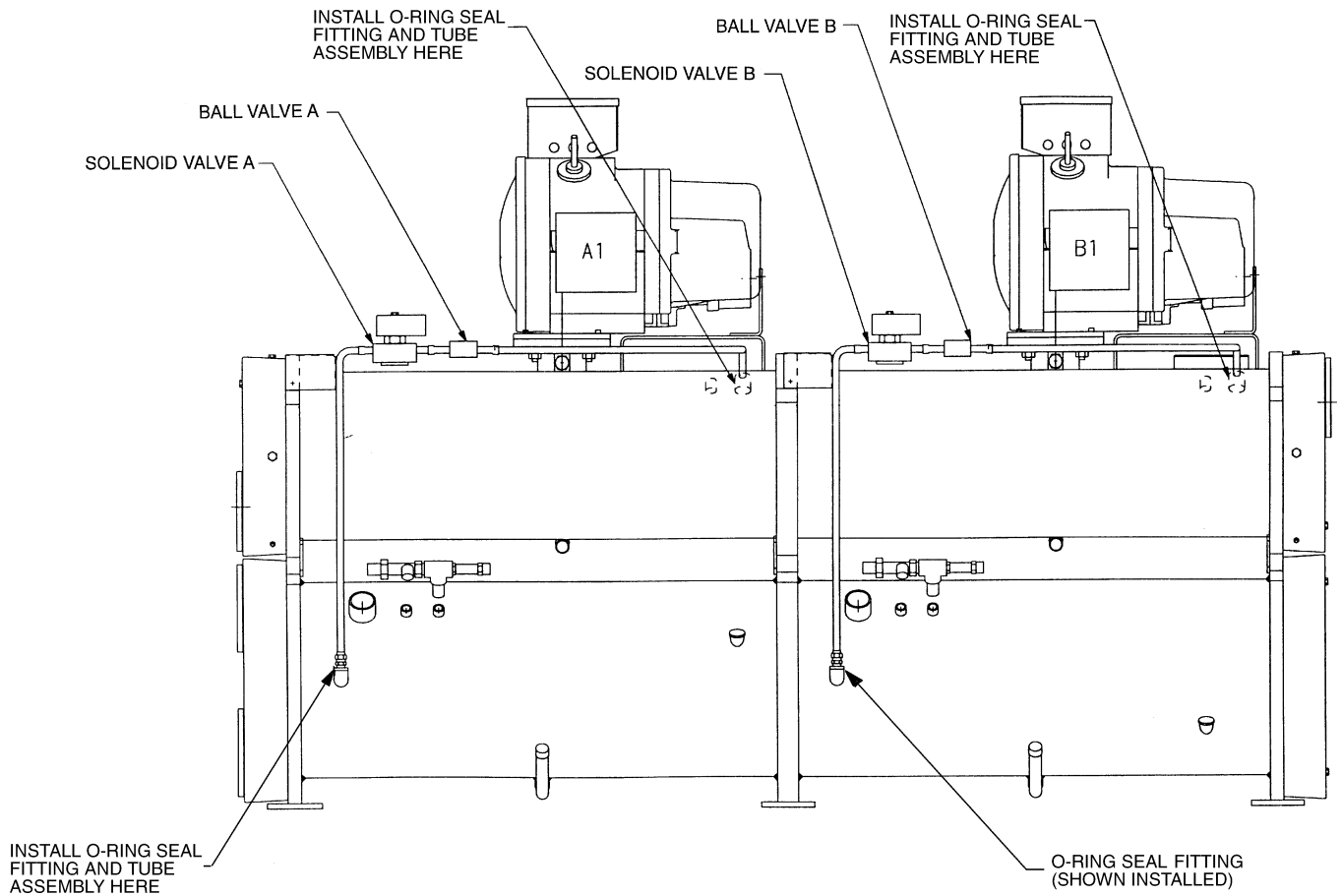

Fig. 1 — Installing Fittings, 30GXN,R (Typical Size 080-150, 160 Shown)



**Fig. 2 — Installing Fittings and Valves, 30HX (Typical)**

**30GXN,R UNITS ONLY** — Using good brazing practice, braze the  $\frac{5}{8}$ -in. minimum load tubing to the copper nipple on the discharge line (minimum load port) between the condenser coil and oil separator. See Fig. 1, 3A and 3B.

**Step 3 — Dehydrate and Recharge Circuit —**

When piping has been completed, leak test the assembly. If one of the O-ring seal fittings leaks, slowly tighten the O-ring nut until the leak stops. If this does not fix the leak, the connection must be reinstalled using a new O-ring in the fitting. Contact your Carrier representative for assistance in locating these parts.

After leak testing, evacuate, dehydrate, and recharge the circuit using an approved refrigerant recovery device. Correct type and amount of refrigerant are listed on unit nameplate and in base unit documentation.

**Step 4 — Install Control Wiring**

**⚠ WARNING**

Be sure all power to the unit is off before proceeding. Lock out and safety-tag all disconnects.

*Wires between field-installed components and unit control box must be enclosed in field-supplied conduit. Follow all local*

codes and NEC (National Electrical Code, U.S.A.). Wire size must be no. 16 AWG (American Wire Gage) (1.5 mm<sup>2</sup>) minimum. See Fig. 4 and 5 for field wiring.

**30HX UNITS** — Remove the screws holding the right-side access panel to the unit control box. Open the right-side access panel.

Route wires through field-supplied conduit and attach the conduit to the unit control box, using a suitable conduit fitting and one of the available  $\frac{7}{8}$ -in. knockout openings. Attach the other end of the conduit to the solenoid valve, using a suitable fitting. Repeat for the other circuit. See Fig. 4.

**30GXN,R UNITS** —Route the field-supplied water proof conduit from the solenoid valves to the control box at the end of the unit. See Fig. 4 and 5.

**ALL UNITS** — Using good wiring practice, connect a white wire from the solenoid valve on circuit A to a white wire from the solenoid valve on circuit B. Connect both wires to TB2-9 (30HX) or TB4-2 (30GX).

Connect a pink wire to the solenoid valve on circuit A.

Connect a gray wire to the solenoid valve on circuit B. Connect both the pink and gray wires to TB5-9 for all units.

Figure 4 shows the correct location of the wiring connection points on the chiller.

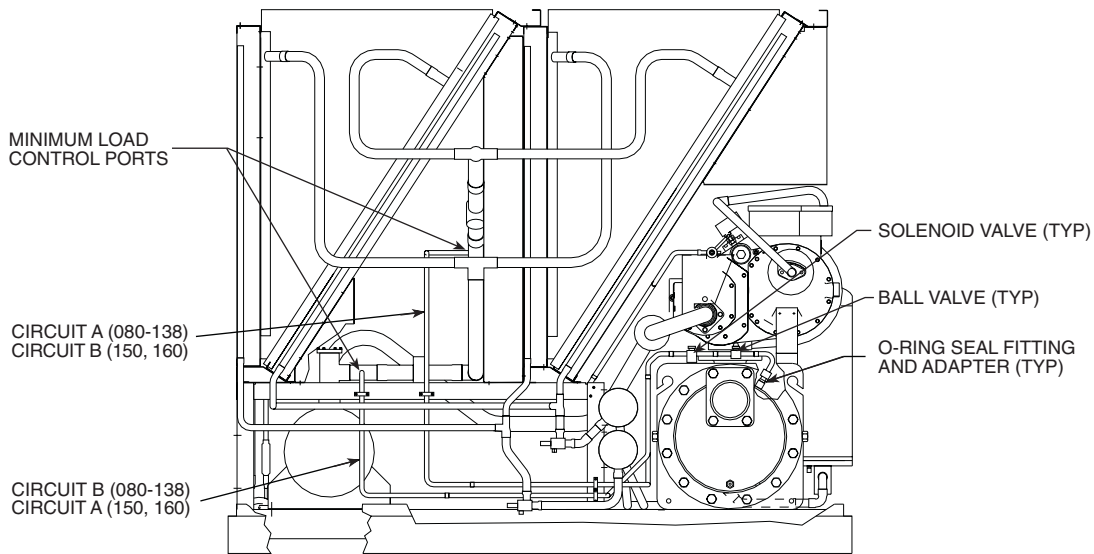

→ **Fig. 3A — Typical Piping and Valve Installation 30GXN,R080-178 and Associated Modular Sizes (080-150, 160 Shown)**

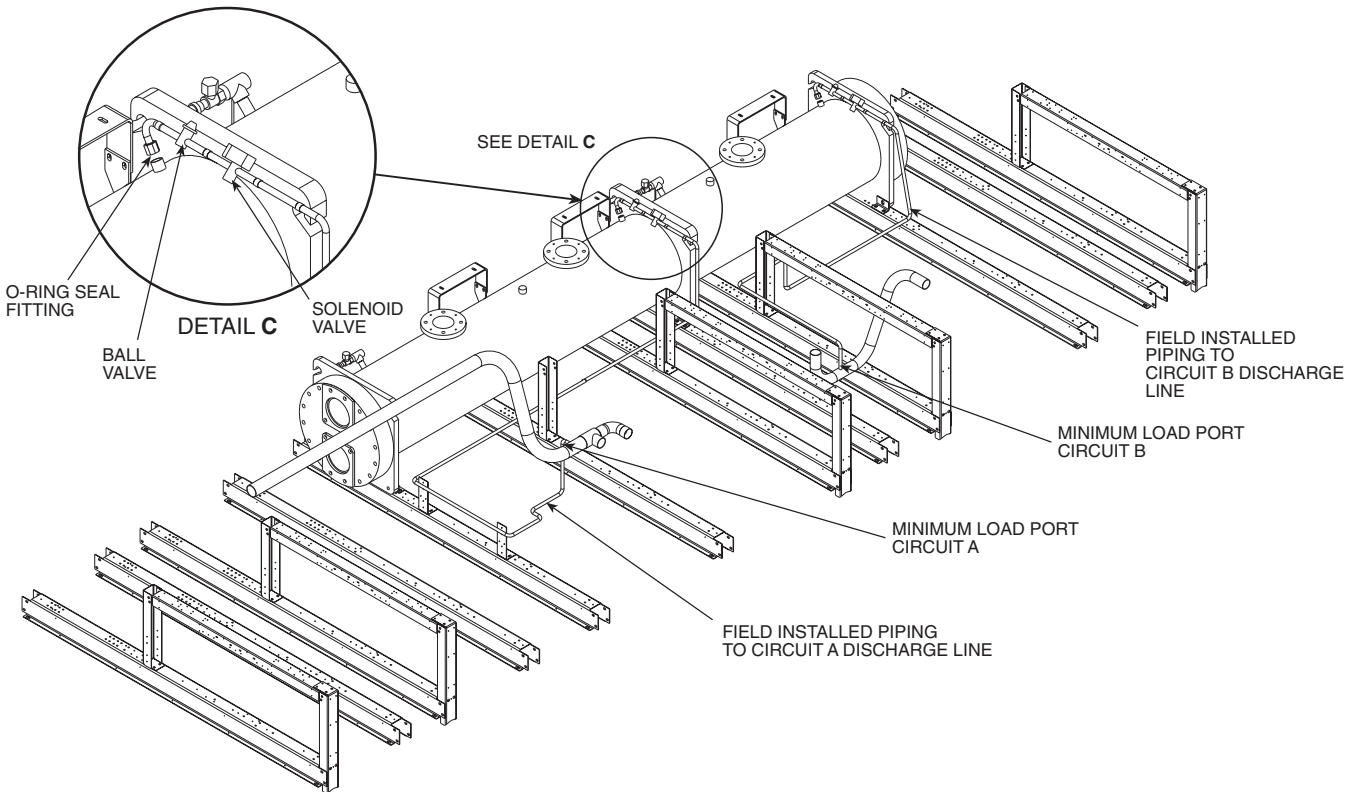

→ **Fig. 3B — Typical Piping and Valve Installation 30GXN,R204-350 and Associated Modular Sizes (204-268 Shown)**

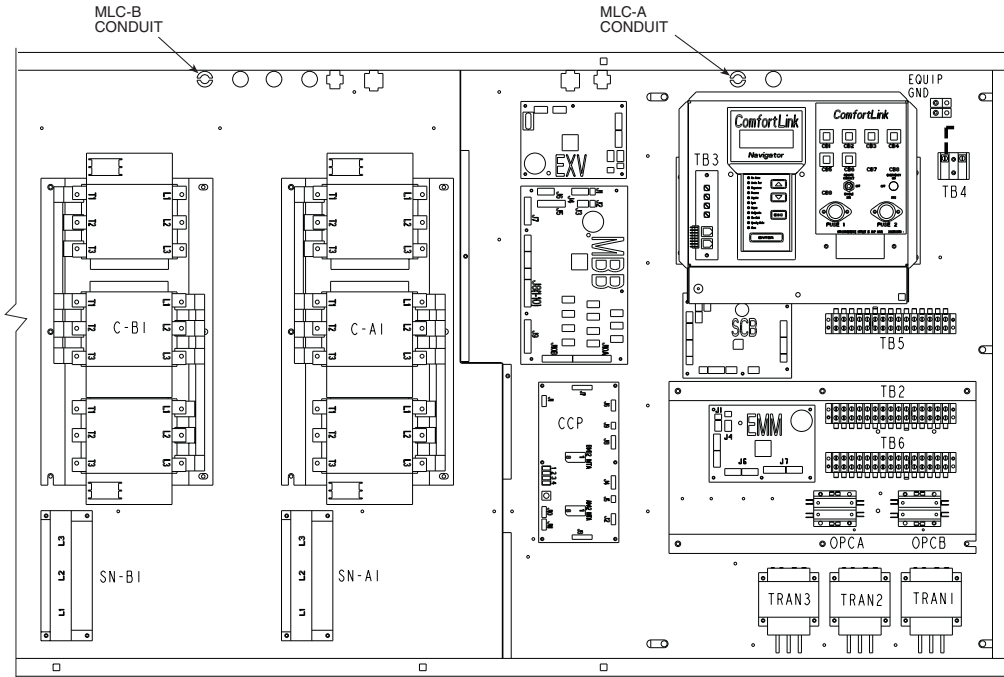
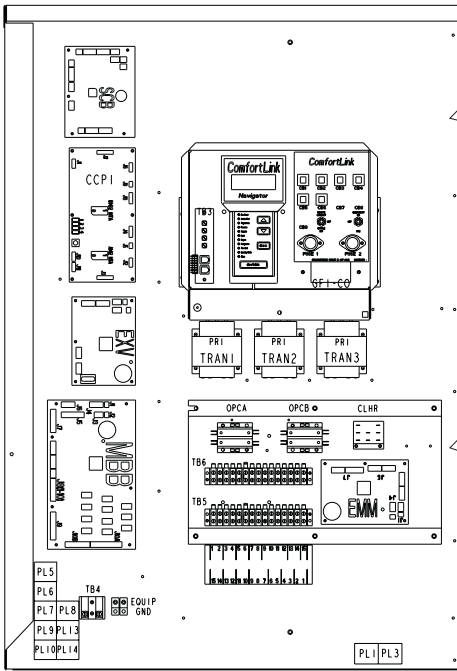

LEGEND

- C** — Contactor Compressor
- CB** — Circuit Breaker
- CCP** — ComfortLink™ Compressor Protection
- CLHR** — Cooler Heater Relay
- EMM** — Energy Management Module
- EQUIP** — Equipment
- EXV** — Electronic Expansion Valve
- FB** — Fuse Block
- FR** — Fan Relay
- GFI-CO** — Ground Fault Interrupter Convenience Outlet

- GND** — Ground
- LR** — Loader Relay
- MLC** — Minimum Load Control
- OPC** — Oil Pump Contactor
- PL** — Plug Assembly
- PRI** — Primary
- SCB** — Screw Compressor Board
- SN** — Sensor (Toroid)

- SPT** — Suction Pressure Transducer
- TB** — Terminal Block
- TRAN** — Transformer
- Terminal Block Connection
- Unmarked Splice
- Factory Wiring

\*And associated modular sizes.

Fig. 4 — Typical Minimum Load Control Wiring

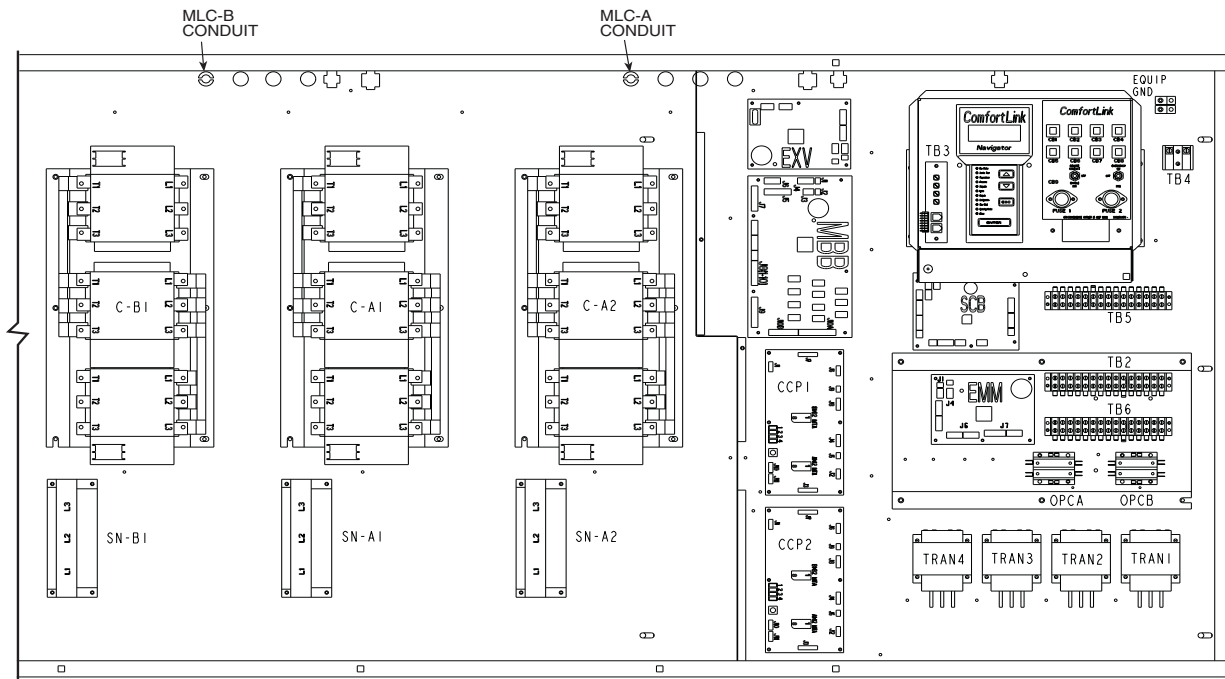

30HX206-271

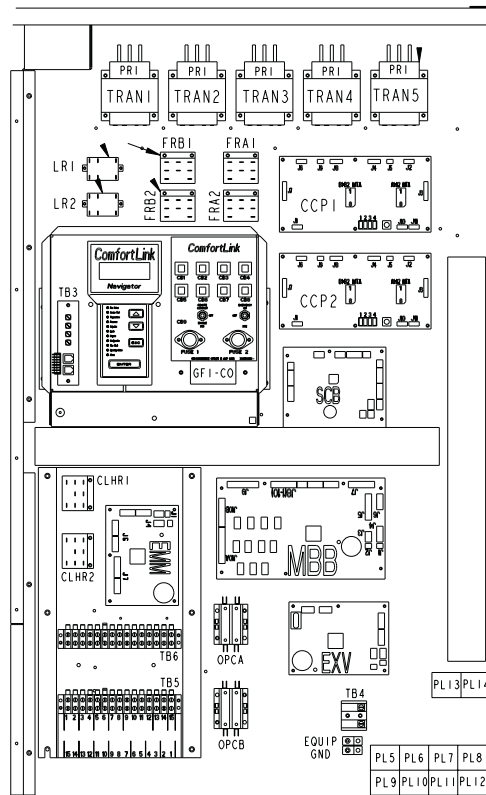

30GXN,R204-350\*

\*And associated modular sizes.

→

Fig. 4 — Typical Minimum Load Control Wiring (cont)

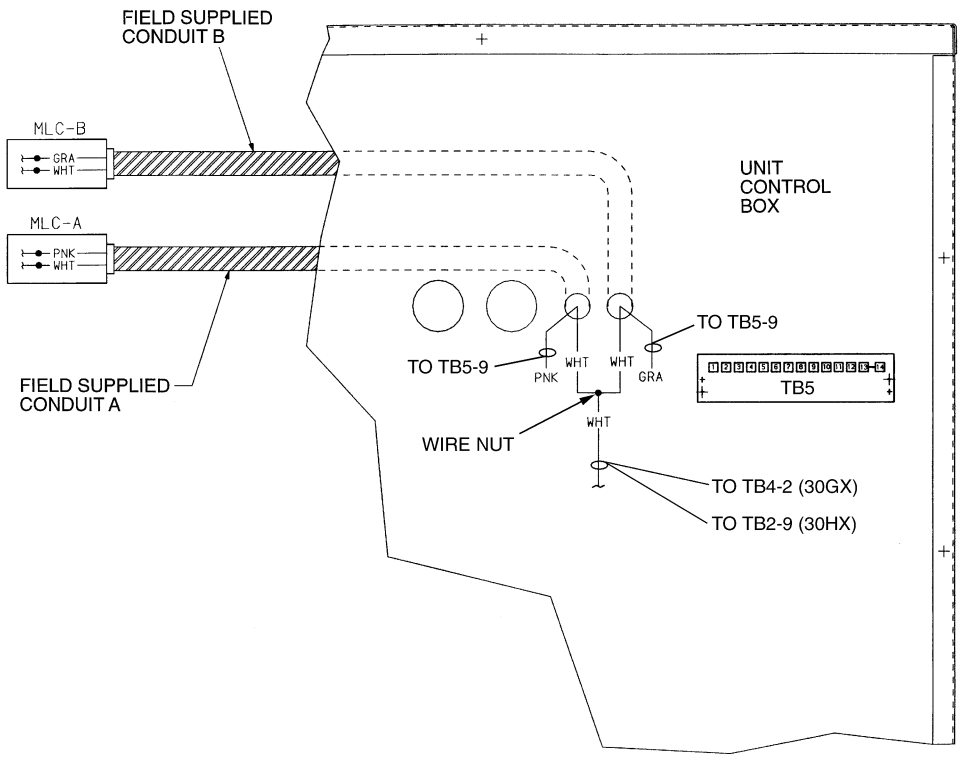

**Fig. 4 — Typical Minimum Load Control Wiring (cont)**

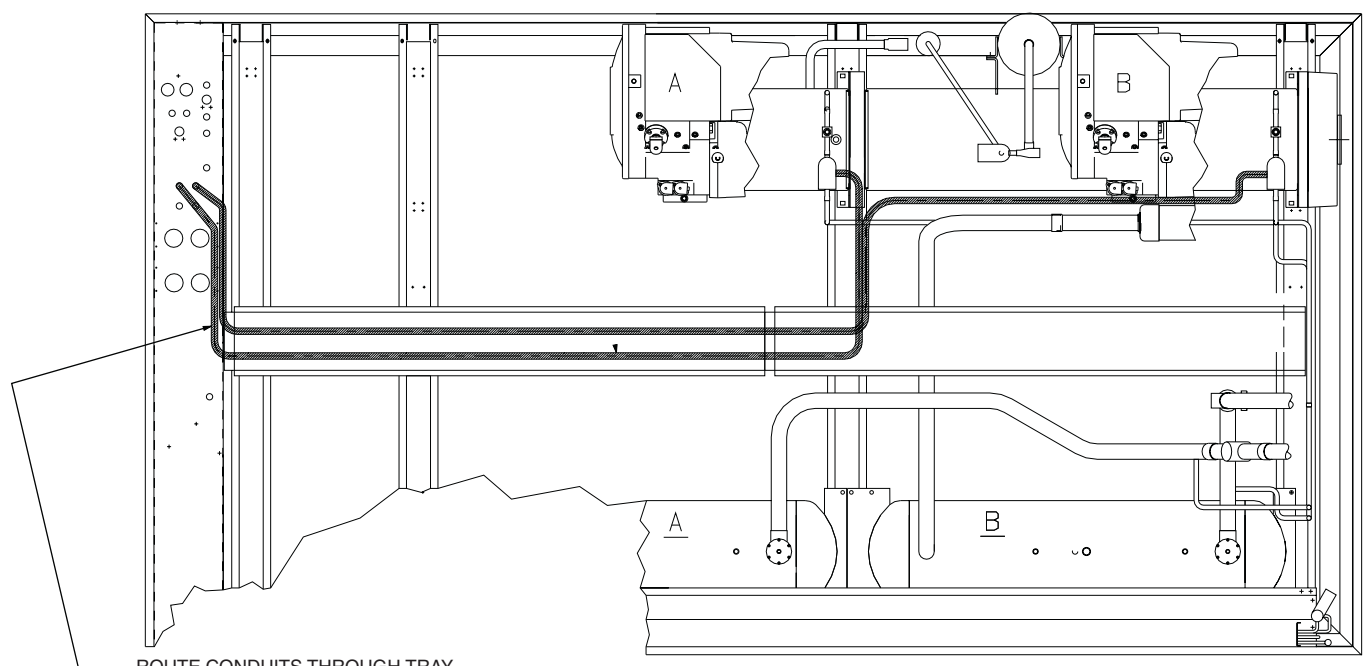

ROUTE CONDUITS THROUGH TRAY AND ATTACH TO BOTTOM OF SHELF ON TB-4 SIDE OF CONTROL BOX

**Fig. 5 — Routing Field-Supplied Wiring and Conduit (30GXN,R Shown)**

## Step 5 — Configure Unit for Minimum Load Control

— Once the piping installation and wiring installation are complete, the chiller must be configured for minimum load control operation. This may be done using the Navigator. Set the Enable/Off/Remote/Contact switch in the OFF position.

1. Press key until display reads 'SELECT A MENU ITEM.' Press key to light up Configuration mode. Press . Press key to select sub-mode 'OPT1'. Press .
2. Press the down arrow key to select MLVS NO.
3. To enable the minimum load valve feature, press the key.
4. The display may read as follows. (If not, skip to Step 7.)  
ENTER PASSWORD
5. Press 1 1 1 1 then key.
6. The Navigator again displays the following:  
MLVS NO
7. Press key and The Navigator displays:  
MLVS YES

The chiller is now configured for minimum load valve control.

## Step 6 — Test Minimum Load Relay Outputs

— After the accessory components are installed and the unit is recharged and reconfigured, test the operation of the relay and solenoid valve using the Service Test software function. Test both circuits as follows:

1. Press the key until the Navigator displays 'SELECT A MENU ITEM.' Press the key and light up the Service Test mode. Press the key. Press the key and 'TEST OFF' will be displayed with 'OFF' flashing. Press the key then key and the Navigator displays 'TEST ON.' Switch the Enable/Off/Remote contact switch to the Enable position.
2. The display may read as follows. (If not, skip to Step 4.)  
ENTER PASSWORD
3. Press 1 1 1 1 then key.
4. Press the down arrow key to select the 'COMP' sub-mode. Press the key and key to display MLV OFF.
5. Press the key.

6. Press the and key to energize the relays. The display reads:

MLV ON

An audible click will be heard. Verify that the solenoid valves for both circuits are energized.

7. Press the , , and keys to turn the solenoids off. When finished, exit the Service Test mode (change 'TEST ON' to 'TEST OFF'). Put the Enable/Off/Remote Contact switch in the desired position.

After testing is complete, recheck all electrical connections for proper location and tightness. Replace and secure the access panels for the unit control box.

## Step 7 — Adjust Setting of Minimum Load Ball Valve

— Before the installation is complete, the minimum load ball valve must be adjusted to suit the application. Calibrate one circuit at a time as follows:

1. Adjust the ball valve so that it is approximately half open.
2. Operate the chiller in Service Test mode, with one circuit operating, and all compressor loaders deenergized.

NOTE: Operation of the chiller in Manual Control mode is described in the Controls, Start-Up, Operation, and Troubleshooting Guide that is included with the 30GXN,GXR,HX ComfortLink™ chillers.

3. Record the cooler  $\Delta T$  (the difference between cooler entering fluid temperature and cooler leaving fluid temperature) at this fully unloaded condition.
4. Use the Service Test feature to enable the minimum load valve output.
5. Observe and record the cooler  $\Delta T$  with the minimum load valve energized.
6. Adjust the minimum load ball valve until the cooler temperature difference reading from Step 5 is equal to half of the temperature difference reading from Step 3.
7. Open the ball valve to decrease the temperature difference or close the ball valve to increase the temperature difference ( $\Delta T$ ). When the valve is adjusted correctly, the difference between cooler entering and leaving fluid temperatures when the minimum load control is energized must be at least half of the temperature difference when the minimum load control is deenergized. For example, if the difference between the cooler entering and leaving water temperature is 3° F with the valve deenergized, then the difference between cooler entering and leaving water temperature must be at least 1.5° F with the valve energized.

Once the outputs have been tested and the ball valve adjusted, the installation is complete.