



## Installation Instructions

Part Number 920077

**IMPORTANT:** Read entire instructions before starting the installation.

### ⚠ CAUTION

Do not remove the sensor on the thermostat circuit board. Removing the sensor will damage the thermostat. The sensor must be present even if remote room sensors are used.

### SAFETY CONSIDERATIONS

Read and follow manufacturer instructions carefully. Follow all local electrical codes during installation. All wiring must conform to local and national electrical codes. Improper wiring or installation may damage sensor.

Recognize safety information. This is the safety alert symbol ⚠. When the safety alert symbol is present on equipment or in the instruction manual, be alert to the potential for personal injury.

Understand the signal words DANGER, WARNING, and CAUTION. These words are used with the safety alert symbol. DANGER identifies the most serious hazards which will result in severe personal injury or death. WARNING signifies a hazard which could result in personal injury or death. CAUTION is used to identify unsafe practices which would result in minor personal injury or property damage.

### GENERAL

The Remote Room Sensor (RRS) senses space temperature when configured in a 33CS VVT® (Variable Volume and Temperature) or TEMP system. The sensor senses temperature with a range of 30 to 180 F.

Up to 4 remote room sensors may be used. When more than one sensor is used, the results are averaged.

### INSTALLATION

**Step 1 — Sensor Location** — The sensor can be located up to 1000 ft from the thermostat. The RRS should be located on an interior wall, out of direct sunlight, and out of the path of the supply air.

**Step 2 — Wiring Requirements** — The RRS wiring has the following requirements:

1. All system wiring must comply with all applicable local and national codes.
2. All control, communication bus, and sensor wiring should be color coded in conformance with Carrier recommendations.
3. All wiring should be 2-conductor, 18- to 22-gage, shielded wire. The maximum distance between the RRS and the thermostat for 18-gage wire is 1000 ft. The maximum distance between the RRS and the thermostat for 22-gage wire is 500 ft.

4. Connect one end of the wire shield to the earth/chassis ground. Do not connect shield at sensor side. Cut and tape shield at other end of wire.

### ⚠ CAUTION

Do not ground the shielded wire in more than one location. If the shield is grounded in two or more locations, an electrical charge may form around the wire and disrupt communication.

5. When more than one RRS is used, all RRSs must be wired in parallel. When adding additional remote room sensors, a field-supplied 9.2 K ohm resistor must be added to the connector block for each additional sensor.

### Step 3 — Install Sensor

1. Cut or drill a 1/2-in. hole in the wall at the location the RRS will be installed.
2. Remove the RRS base from the case. Route the sensor wire through the wall and through the hole in the base plate. See Fig. 1.
3. Use the mounting screw included with the RRS to mount the RRS base plate to the wall. Be sure to line up hole in wall with hole in base plate of RRS.
4. Make wiring connections to the back of the RRS case by connecting the RED wire to (+) and the BLACK wire to (-).
5. Attach the RRS case by snapping it onto the base plate.
6. Make wire connections to thermostat connector board. See Fig. 1 and 2. If needed, add field-supplied 9.2 K ohm resistors (required for more than one RRS).

**Step 4 — Configure the Unit Controller** — The Zone Temperature Monitoring option configures the thermostat to use remote room sensors. The Zone Temperature Monitoring option is Category 5, Option 1.

When the option is set to 1, the TEMP system unitary controller thermostat or VVT monitor thermostat will only use its local zone temperature sensor for space temperature information.

When the option is set to 2, the TEMP system unitary controller thermostat or VVT monitor thermostat will only use remote room sensor(s) for space temperature information.

When the option is set to 3, the TEMP system unitary controller thermostat or VVT monitor thermostat will average the space temperature information it receives from the remote room sensor(s) and its local room sensor.

To configure the Zone Temperature Monitoring option, configure Category 5, option 1. The range is 1 to 3. The default value is 1. Raise or lower the set point to the desired value.

**NOTE:** If multiple RRSs are installed to the same thermostat, only option 3 can be used. If a single RRS is installed, all the options are available.

**Step 5 — Calibrate the Sensor** — To calibrate the RRS, configure category 5, option 3 on the thermostat. Obtain an accurate correct temperature reading with a thermometer near the sensor. The range of possible temperatures is 30 to 180 F. Raise or lower the RRS temperature reading until it matches the reading from the thermometer.

**NOTE:** If more than one RRS is used and averaged, measure the temperatures at each sensor and average them to calculate the correct temperature, or place the thermostat in the approximate center of the sensors.

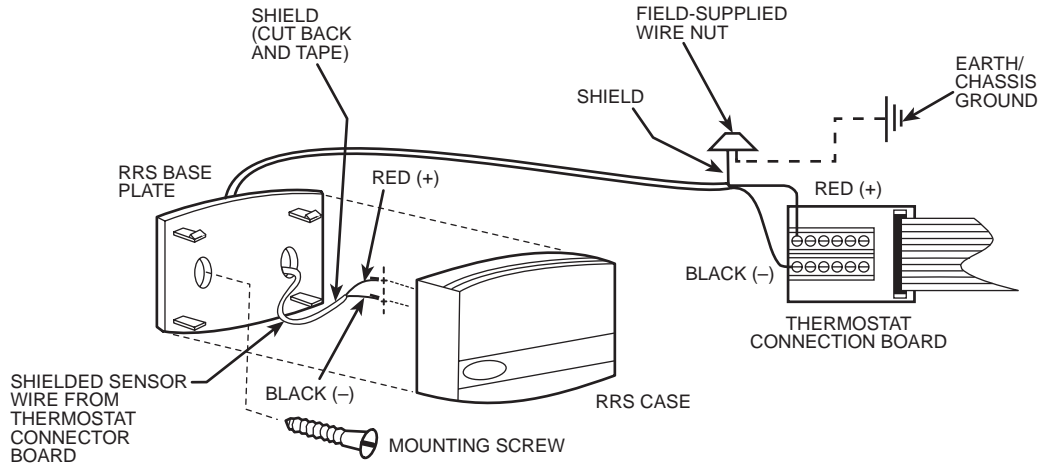

RRS — Remote Room Sensor

**Fig. 1 — Remote Room Sensor Installation**

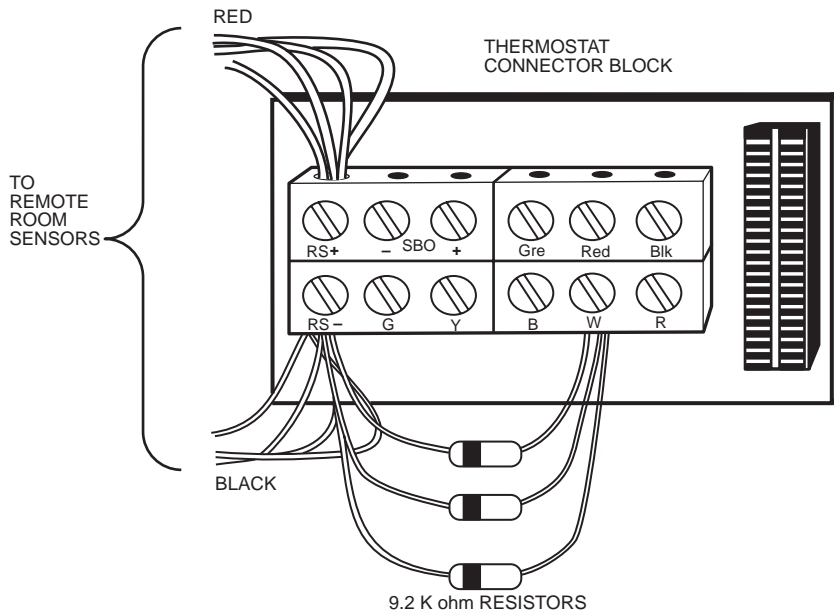

**NOTE:** For each additional sensor (2 or more total) a resistor must be added. Resistors are wired in parallel between terminals RS- and W on the thermostat terminal block. Resistors are available in packs of 20 (part no. 920540).

Example shown is the 4 Remote Room Sensors.

**Fig. 2 — Remote Room Sensor Wiring to Connector Block**