



35KA,KN,KP06-18 Bypass Terminal Units for Variable Air Volume Systems

Installation Instructions

SAFETY CONSIDERATIONS

SAFETY NOTE

Air-handling equipment will provide safe and reliable service when operated within design specifications. The equipment should be operated and serviced only by authorized personnel who have a thorough knowledge of system operation, safety devices and emergency procedures.

Good judgement should be used in applying any manufacturer's instructions to avoid injury to personnel or damage to equipment and property.

WARNING

Disconnect all power to the unit before performing maintenance or service. Unit may automatically start if power is not disconnected. Electrical shock and personal injury could result.

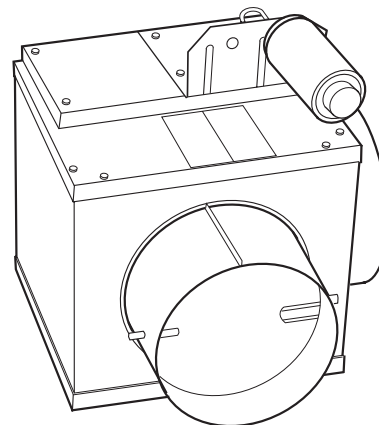

Fig. 1 — 35K Bypass Terminal

PRE-INSTALLATION

General — The 35K unit is a single duct, variable volume terminal available with factory-installed pneumatic or analog electronic control options. Figure 1 shows the basic box.

STORAGE AND HANDLING — Inspect for damage upon receipt. Shipping damage claims should be filed with shipper at time of delivery. Store in a clean, dry, and covered location. Do not stack cartons. When unpacking units, care should be taken that the inlet collars and externally mounted components do not become damaged. Do not lift units using collars, sensors or externally mounted components as handles. If a unit is supplied with electric or hot water heat, care should be taken to prevent damage to these devices. Do not lay uncrated units on end or sides. Do not stack uncrated units over 6 ft high. Do not handle control boxes by tubing connections or other external attachments. Table 1 shows component weights.

INITIAL INSPECTION — Once items have been removed from the carton, check carefully for damage to duct connections, coils or controls. File damage claim immediately with transportation agency and notify Carrier.

UNIT IDENTIFICATION — Each unit is supplied with a shipping label and an identification label. See Fig. 2.

INSTALLATION PRECAUTION — Check that construction debris does not enter unit or ductwork. Do not operate the central-station air-handling fan without final or construction filters in place. Accumulated dust and construction debris distributed through the ductwork can adversely affect unit operation.

SERVICE ACCESS — Provide service clearance for unit access.

CODES — Install units in compliance with all applicable code requirements.

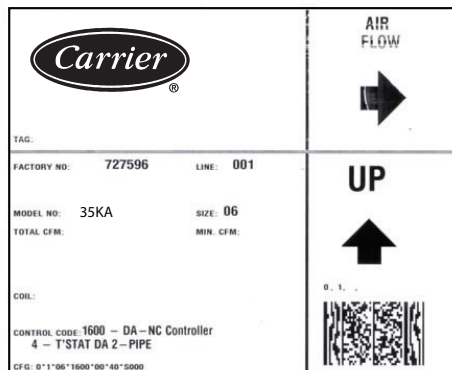

Fig. 2 — Unit Identification Label

UNIT SUSPENSION — See Fig. 3 for unit suspension details. Unit dimensional drawings are shown in Fig. 4-6.

Warranty — All Carrier-furnished items carry the standard Carrier warranty.

No periodic preventative maintenance required, unless called for specific control sequence.

Table 1 — 35K Unit Weights

35K SIZE	UNIT ONLY (lb)	UNIT WITH ACTUATOR/CONTROLLER (lb)
06	19	22
08	21	24
10	26	26
12	32	35
14	40	43
16	44	47
18	47	50

NOTE:

1. Unit casing is 20 gage.
2. Unit insulation is 1/2-in. thick, 1.5-lb Tuf-Skin Rx™, dual density.
3. Units rated with standard linear flow sensor.

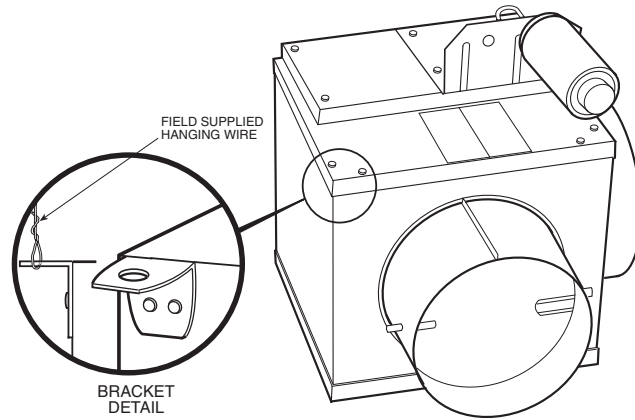
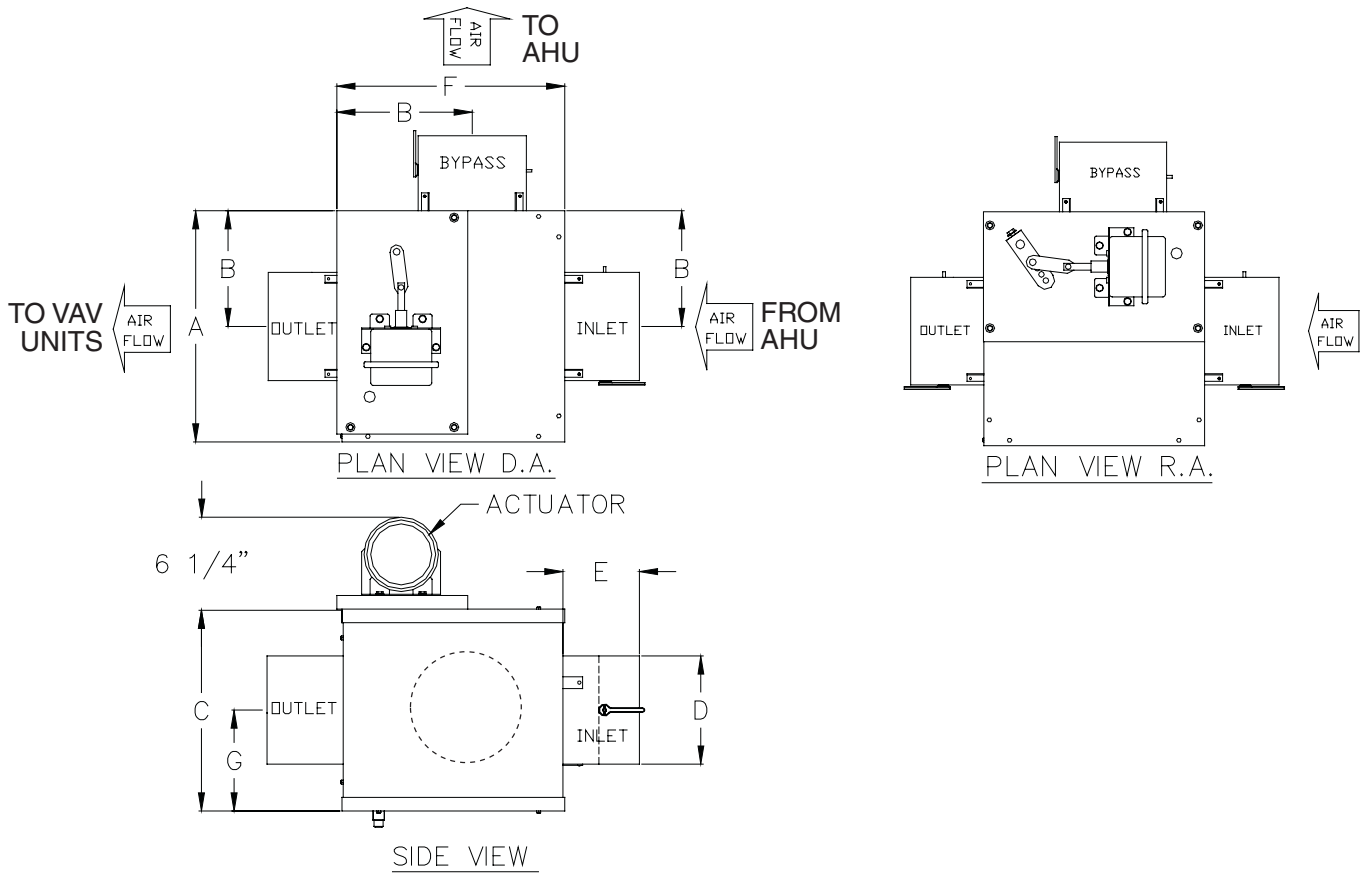

Fig. 3 — Typical Unit Suspension with Brackets



35K UNIT SIZE	A	B	C	D	E	F	G
06	12 ⁷ / ₈	7 ¹ / ₈	11 ¹ / ₈	5 ⁷ / ₈	4 ¹ / ₄	12 ³ / ₈	5 ⁹ / ₁₆
08	12 ⁷ / ₈	7 ¹ / ₈	11 ¹ / ₈	7 ⁷ / ₈	5 ¹ / ₄	12 ³ / ₈	5 ⁹ / ₁₆
10	14 ⁷ / ₈	8 ¹ / ₈	13 ¹ / ₈	9 ⁷ / ₈	6 ¹ / ₄	14 ³ / ₈	6 ⁹ / ₁₆
12	18 ⁷ / ₈	10 ¹ / ₈	17 ¹ / ₈	11 ⁷ / ₈	7 ¹ / ₄	18 ³ / ₈	8 ⁹ / ₁₆
14	18 ⁷ / ₈	10 ¹ / ₈	17 ¹ / ₈	13 ⁷ / ₈	8 ¹ / ₄	18 ³ / ₈	8 ⁹ / ₁₆
16	22 ⁷ / ₈	12 ¹ / ₈	21 ¹ / ₈	15 ⁷ / ₈	9 ¹ / ₄	22 ³ / ₈	10 ⁹ / ₁₆
18	22 ⁷ / ₈	12 ¹ / ₈	21 ¹ / ₈	17 ⁷ / ₈	10 ¹ / ₄	22 ³ / ₈	10 ⁹ / ₁₆

LEGEND

- AHU** — Air-Handling Unit
- DA** — Direct Acting
- NFPA** — National Fire Protection Agency
- RA** — Reverse Acting
- UL** — Underwriters Laboratories
- VAV** — Variable Air Volume

NOTES:

1. Dimensions are in inches.
2. 20 gage steel construction.
3. The "D" dimension is the diameter of the inlet, bypass, and outlet connection.
4. The 1/2-in. dual density coated insulation meets NFPA 90A and UL 181.
5. The damper operates on a 0 to 20 psi thermostat signal.
6. Unit may be field-rotated 180 degrees if necessary to have controls located on the bottom of the unit.

Fig. 4 — Bypass Terminal with Pneumatic Controls

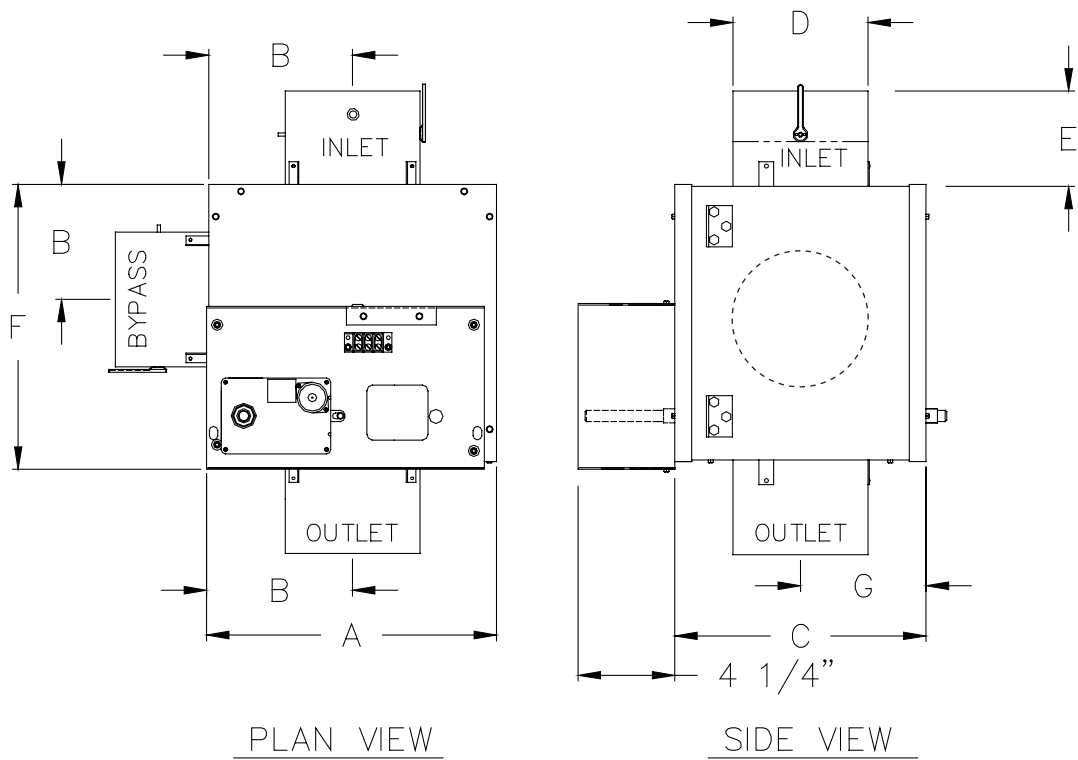

35K UNIT SIZE	A	B	C	D	E	F	G
06	12 ⁷ / ₈	7 ¹ / ₈	11 ¹ / ₈	5 ⁷ / ₈	4 ¹ / ₄	12 ³ / ₈	5 ⁹ / ₁₆
08	12 ⁷ / ₈	7 ¹ / ₈	11 ¹ / ₈	7 ⁷ / ₈	5 ¹ / ₄	12 ³ / ₈	5 ⁹ / ₁₆
10	14 ⁷ / ₈	8 ¹ / ₈	13 ¹ / ₈	9 ⁷ / ₈	6 ¹ / ₄	14 ³ / ₈	6 ⁹ / ₁₆
12	18 ⁷ / ₈	10 ¹ / ₈	17 ¹ / ₈	11 ⁷ / ₈	7 ¹ / ₄	18 ³ / ₈	8 ⁹ / ₁₆
14	18 ⁷ / ₈	10 ¹ / ₈	17 ¹ / ₈	13 ⁷ / ₈	8 ¹ / ₄	18 ³ / ₈	8 ⁹ / ₁₆
16	22 ⁷ / ₈	12 ¹ / ₈	21 ¹ / ₈	15 ⁷ / ₈	9 ¹ / ₄	22 ³ / ₈	10 ⁹ / ₁₆
18	22 ⁷ / ₈	12 ¹ / ₈	21 ¹ / ₈	17 ⁷ / ₈	10 ¹ / ₄	22 ³ / ₈	10 ⁹ / ₁₆

LEGEND

NFPA — National Fire Protection Agency
UL — Underwriters Laboratories

NOTES:

1. Dimensions are in inches.
2. 20 gage steel construction.
3. The "D" dimension is the diameter of the inlet, bypass, and outlet connection.
4. The 1/2-in. dual density coated insulation meets NFPA 90A and UL 181.
5. The damper operates on a 24 volt thermostat signal.
6. Unit may be field-rotated 180 degrees if necessary to have controls located on the bottom of the unit.

Fig. 5 — Bypass Terminal with Analog Electronic Controls

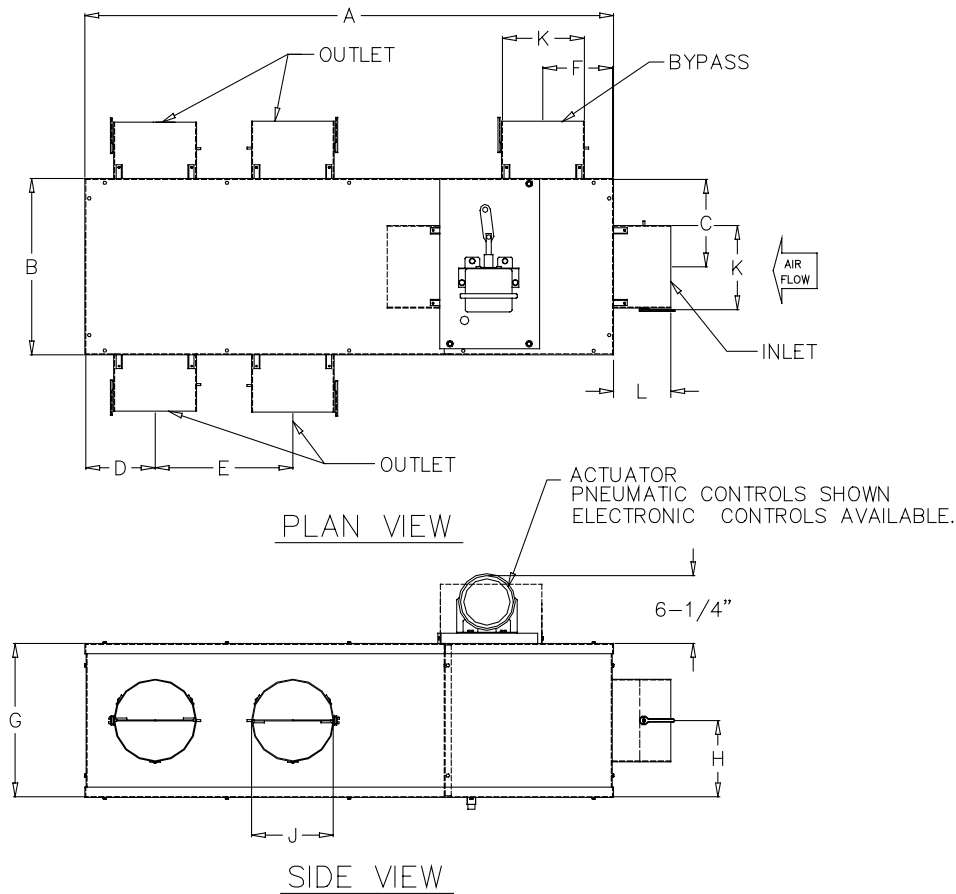

35K UNIT SIZE	A	B	C	D	E	F	G	H	J	K	L
06	38 ³ / ₈	12 ⁷ / ₈	7 ¹ / ₈	5 ¹ / ₈	10	5 ¹ / ₄	11 ¹ / ₈	5 ⁹ / ₁₆	5 ⁷ / ₈	5 ⁷ / ₈	4 ¹ / ₄
08	38 ³ / ₈	12 ⁷ / ₈	7 ¹ / ₈	5 ¹ / ₈	10	5 ¹ / ₄	11 ¹ / ₈	5 ⁹ / ₁₆	5 ⁷ / ₈	7 ⁷ / ₈	5 ¹ / ₄
10	44 ³ / ₈	14 ⁷ / ₈	8 ¹ / ₈	6 ¹ / ₈	12	6 ¹ / ₄	13 ¹ / ₈	6 ⁹ / ₁₆	7 ⁷ / ₈	9 ⁷ / ₈	6 ¹ / ₄
12	52 ³ / ₈	18 ⁷ / ₈	10 ¹ / ₈	6 ¹ / ₈	12	8 ¹ / ₄	17 ¹ / ₈	8 ⁹ / ₁₆	7 ⁷ / ₈	11 ⁷ / ₈	7 ¹ / ₄
14	52 ³ / ₈	18 ⁷ / ₈	10 ¹ / ₈	6 ¹ / ₈	12	8 ¹ / ₄	17 ¹ / ₈	8 ⁹ / ₁₆	9 ⁷ / ₈	13 ⁷ / ₈	8 ¹ / ₄
16	56 ³ / ₈	22 ⁷ / ₈	12 ¹ / ₈	7 ¹ / ₈	14	10 ¹ / ₄	21 ¹ / ₈	10 ⁹ / ₁₆	9 ⁷ / ₈	15 ⁷ / ₈	9 ¹ / ₄
18	56 ³ / ₈	22 ⁷ / ₈	12 ¹ / ₈	7 ¹ / ₈	14	10 ¹ / ₄	21 ¹ / ₈	10 ⁹ / ₁₆	9 ⁷ / ₈	17 ⁷ / ₈	10 ¹ / ₄

LEGEND

NFPA — National Fire Protection Agency
 UL — Underwriters Laboratories

NOTES:

1. Dimensions are in inches.
2. 20 gage steel construction.
3. The "D" dimension is the diameter of the inlet, bypass, and multiple outlet connections.
4. The 1/2-in. dual density coated insulation meets NFPA 90A and UL 181.
5. The damper operates on a 0 to 20 psi or 24 volt thermostat signal.

Fig. 6 — Bypass Terminal with Pneumatic or Analog Electronic Controls and Multiple Outlets

CONTROL ARRANGEMENTS

The 35K bypass terminal unit is offered with a wide variety of factory-mounted controls that regulate the volume of air delivery from the unit and respond to cooling and heating load requirements of the conditioned space by opening and closing the bypass damper. Stand-alone controls will fulfill the thermal requirements of a given control space. These devices are available in both pneumatic and electronic arrangements. Control offerings are:

35KA: Analog electronic

35KP: Pneumatic

35KN: No control or field-supplied control by others

Each control approach offers a variety of operating functions; a control package number identifies combinations of control functions. The following listings contain the basic function arrangements for each control offering. Because of the variety of functions available, circuit diagrams, operating sequences, and function descriptions are contained in separate Application Data publications. Refer to the specific control publication for details.

The 4-digit control codes represent the different control arrangements available for the 35K bypass terminal. Refer to the 35K price pages for more information on control codes.

Analog Electronic Control Arrangement — The damper actuator responds to changes in the thermostat demand. As the room temperature increases, the room thermostat modulates the room damper open and the bypass damper is closed. As the room temperature decreases, the room thermostat modulates the room damper closed and the bypass damper is opened.

All analog electronic control arrangements include a sheet metal enclosure, flow probe, thermostat, and damper actuator and analog controller.

3500 Electric Temperature Responsive

Pneumatic Control Arrangement — The damper actuator responds to changes in the thermostat demand. As the room temperature increases, the room thermostat modulates the room damper open and the bypass damper is closed. As the room temperature decreases, the room thermostat modulates the room damper closed and the bypass damper is opened.

All pneumatic control arrangements include a sheet metal enclosure, flow probe, damper actuator and pneumatic controller. Thermostats are not included as standard.

1600 Pneumatic DA-NC control

1601 Pneumatic RA-NO control

LEGEND

DA: Direct-acting thermostat

RA: Reverse-acting thermostat

NO: Normally open damper position

NC: Normally closed damper position

The single function controller provides single functions, i.e., DA-NO. Multi-function controllers are capable of providing DA-NO, DA-NC, RA-NC or RA-NO functions.

No Controls or Direct Digital Electronic Control (DDC) Arrangements (Field-Supplied) —

Control packages are field-supplied for factory mounting, unless otherwise noted. All DDC control arrangements include a standard linear inlet flow sensor, transformer to 24 volts and control enclosure.

Contact Carrier for detail about mounting field-supplied controls.

0000: Field-supplied controls with no controls enclosure

INSTALLATION

Step 1 — Install Volume Control Box

1. Move unit to installation area. Remove unit from shipping package. Do not handle by controls or damper extension rod.
2. The unit has factory-installed brackets on unit as shown in Fig. 3.
3. Suspend units from building structure with straps, rods, or hanger wires. Secure the unit and level it in each direction.

Step 2 — Make Duct Connections

1. Install supply ductwork on unit inlet collar. Check that air-supply duct connections are airtight and follow all accepted medium-pressure duct installation procedures. See Table 2 for pressure data.

NOTE: To ensure proper equipment performance, it is recommended that a length of rigid straight duct equal to 3 times the duct diameter be provided to the inlet. An inlet balancing damper should either be included with the unit (factory-installed option) or field-installed upstream of the unit in the supply ductwork.

2. Install the discharge duct. When a multiple outlet connector is used on the box, connect appropriately sized ductwork to the outlets. Use adapter caps to seal unused outlets. Fully open all balancing dampers.
3. To ensure use of common-diameter air duct, coordinate diameters of box inlet and multiple outlet collars.
4. Insulate duct as required.

NOTE: A straight length of inlet duct is not required before the unit inlet. Ninety degree elbows or tight radius flexible duct immediately upstream of inlet collar should be avoided.

Step 3 — Make Field Wiring or Piping Connections

— Refer to specific unit dimensional submittals and control application diagrams for control specifications. All field wiring must comply with National Electrical Code (NEC) and local requirements. Refer to the wiring diagram on the unit for specific wiring connections.

A field-supplied transformer is required if the unit was not equipped with a factory-installed transformer. A typical analog electronic control wiring diagram is shown in Fig. 7. A typical pneumatic control piping diagram is shown in Fig. 8.

Table 2 — 35K Basic Pressure Data

35K SIZE	MAXIMUM PRIMARY AIRFLOW (cfm)	MINIMUM PRIMARY AIRFLOW (cfm)	MAXIMUM INLET PRESSURE (psig)	MINIMUM PRESSURE (psig)	
				100% Bypass	0% Bypass
06	500	110	0.6	0.43	0.03
08	900	185	0.6	0.44	0.03
10	1300	290	0.6	0.38	0.02
12	2000	420	0.6	0.43	0.03
14	2500	580	0.6	0.38	0.02
16	3600	740	0.6	0.44	0.03
18	4400	740	0.6	0.41	0.02

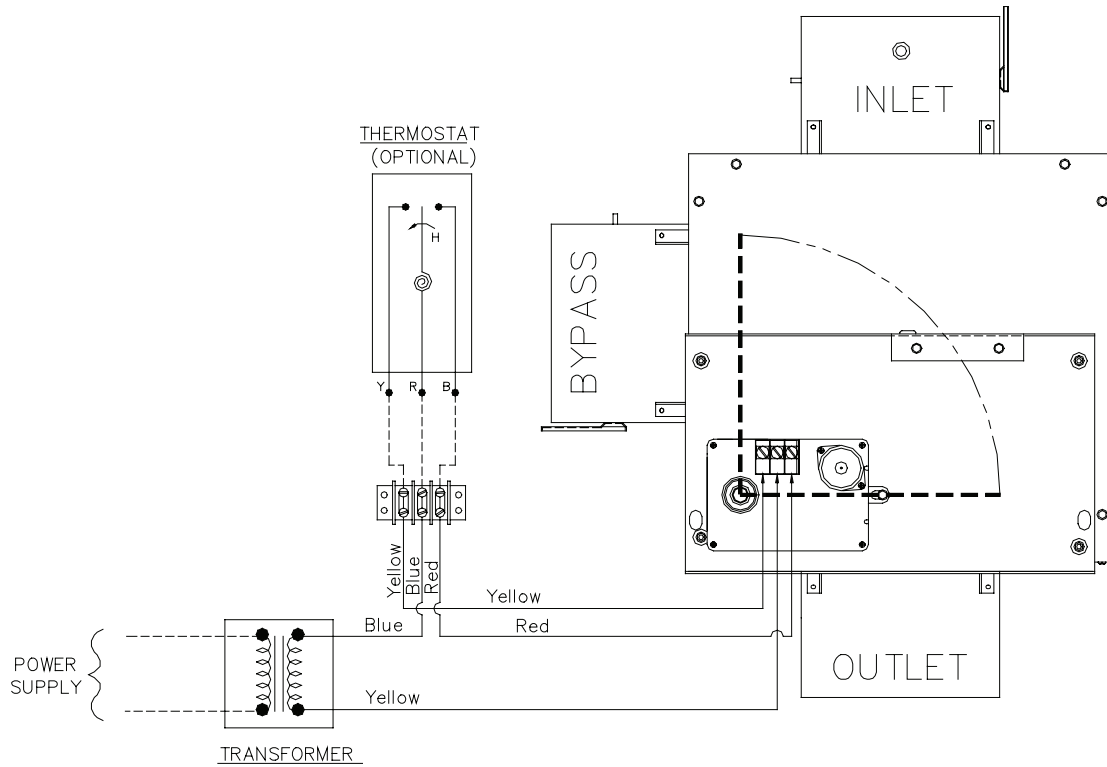

Fig. 7 — Typical Wiring — 35KA Analog Electronic Bypass Terminals

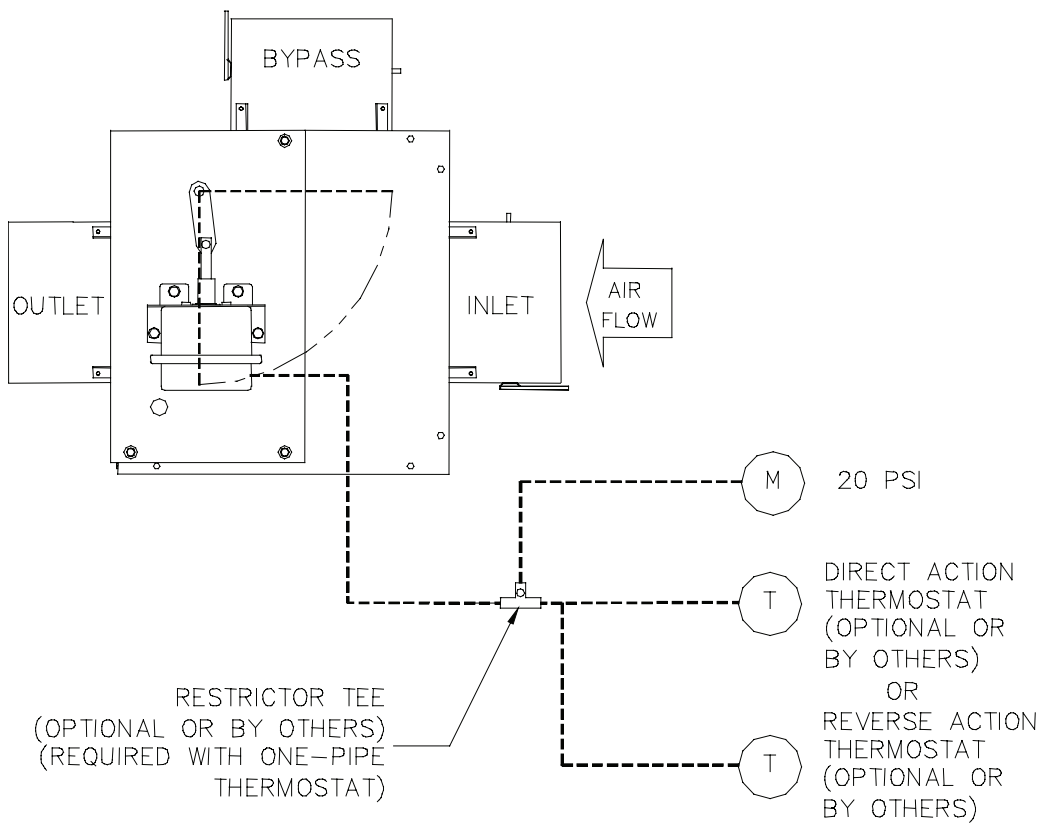

Fig. 8 — Typical Pneumatic Piping — 35KP Pneumatic Bypass Terminals

CONTROL SET UP — BALANCING

The bypass terminal is designed to supply a varying quantity of cold primary air to a space in response to thermostat demand, with the excess air diverted to a secondary discharge outlet. This type of terminal is not equipped with pressure compensating controls. Instead, the thermostat or pressure dependent controller is directly connected to the actuator. To balance the unit, it is necessary to establish a pressure balance between the straight through and full bypass modes of operation. To balance the bypass terminal, perform the following steps:

1. With the actuator fully open (no bypass) and the air system operating normally, establish the desired maximum cooling or heating airflow to be delivered. Adjust the factory-installed optional inlet balancing damper or a

field-installed damper installed upstream of the unit until the desired airflow is reached.

NOTE: Failure to limit the airflow at the inlet of the unit may result in damper failure under some conditions. Discharge airflow may be determined by established balancing procedures appropriate for balancing the diffusers in the system.

2. Determine the supply duct inlet pressure.
3. Set the unit actuator to full bypass mode.
4. Adjust the bypass balancing damper so that the inlet duct pressure is the same as when the actuator was in the fully open position. This ensures that the position of the bypass damper will have minimum effect on the operation of the main air handler.

