



Installation Instructions

CONTENTS

	Page
SAFETY CONSIDERATIONS	1
GENERAL	1
Storage and Handling	1
Initial Inspection	1
Installation Precaution	1
Codes	1
PREINSTALLATION	1-30
Prepare Jobsite for Unit Installation	1
INSTALLATION	30, 31
Step 1 — Install Unit	30
• 36IBAC	
• 36IBAN	
• 36IBAS,M,R,L,J	
Step 2 — Connect Induction Beams to the Piping System	31
Step 3 — Connect Induction Beams to the Condensate Drainage System	31
Step 4 — Connect Induction Beams to the Primary Air Ducting System	31
ADJUSTMENT	31
Airflow Balancing Procedure	31
MAINTENANCE	31
Condensate Float Switch Wiring	31

SAFETY CONSIDERATIONS

SAFETY NOTE

Air-handling equipment will provide safe and reliable service when operated within design specifications. The equipment should be operated and serviced only by authorized personnel who have a thorough knowledge of system operation, safety devices and emergency procedures.

Good judgement should be used in applying any manufacturer's instructions to avoid injury to personnel or damage to equipment and property.

GENERAL

The overhead induction beam distribution unit has been designed to give the customer many years of trouble free service. Each unit contains a row or number of rows of aerodynamic airflow nozzles located within the 20-gage heavy duty housing assembly. These airflow nozzles deliver the proper ventilation air from the main outdoor ventilation unit and produce an airflow profile across the coil. This aerodynamic airflow causes a venturi effect across the coil face, which induces air from the room across the coil surface. When cool water or hot water is pumped through the coil, the induced airflow across the coil is heated or cooled, then mixed with the primary airflow from the nozzles to deliver conditioned airflow to the space.

Storage and Handling — Inspect for damage upon receipt. Shipping damage claims should be filed with shipper at

time of delivery. Store in a clean, dry, and covered location. Do not stack cartons. When unpacking units, care should be taken that the inlet collars and water connections do not become damaged.

CAUTION

Do not lift the unit by the drain pipes, water piping, or metal duct. Units should be lifted using the mounting brackets.

The 36IBAC unit packaging includes a base tray and an inverted box cover. Remove the box cover to fully expose the unit.

The 36IBAN and 36IBAR units are packaged in cardboard cartons. Open the carton top and fold the flaps back to gain access to the unit. Two people are required to lift the unit out of the carton. These units are shipped with the grille attached, and when setting the unit down, care must be taken to put it on a clean, soft surface so as not to scratch the grille face.

The 36IBAS, M, L, and J units are packaged in cardboard cartons. Open the carton top and cut the carton vertically on the side where the duct collar is located. The grille is attached to the unit and should not be removed. After cutting the side of the carton, remove the unit from the box and set it on a clean surface being careful not to scratch the grille.

Initial Inspection — Once items have been removed from the carton, check carefully for damage to duct connections, coils, or controls. File damage claim immediately with transportation agency and notify Carrier.

Installation Precaution — Check that construction debris does not enter unit or ductwork. Accumulated dust and construction debris distributed through the ductwork can adversely affect unit operation.

Codes — Install units in compliance with all applicable code requirements.

PREINSTALLATION

Prepare Jobsite for Unit Installation — To save time and to reduce the possibility of costly errors, set up a complete sample installation in a typical room at jobsite. Check all critical dimensions such as pipe, wire, and duct connection requirements. Refer to job drawings and product dimension drawings as required (see Fig. 1-28). Instruct all trades in their part of the installation.

Refer to Tables 1-6 and Fig. 1-28 for unit data.

CAUTION

Prior to hanging the unit, remove the two cotter pins holding the supply/return section to the grille frame. Failure to remove these pins will prevent access to coils and internal workings of the units.

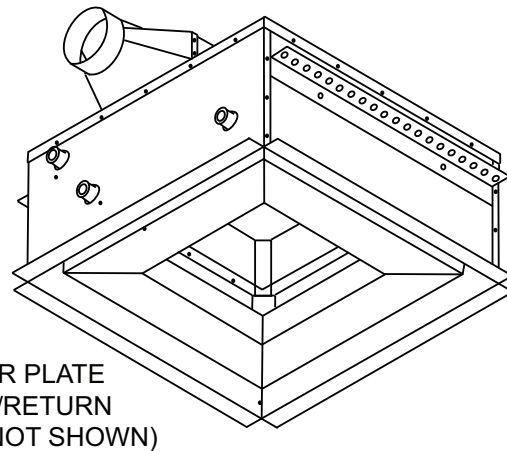
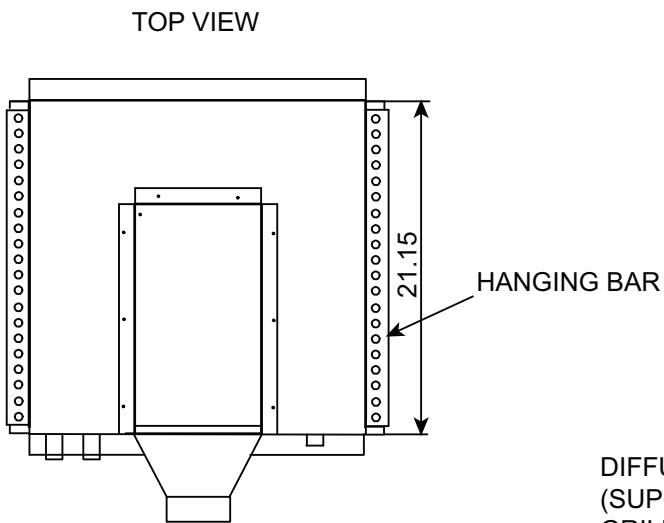
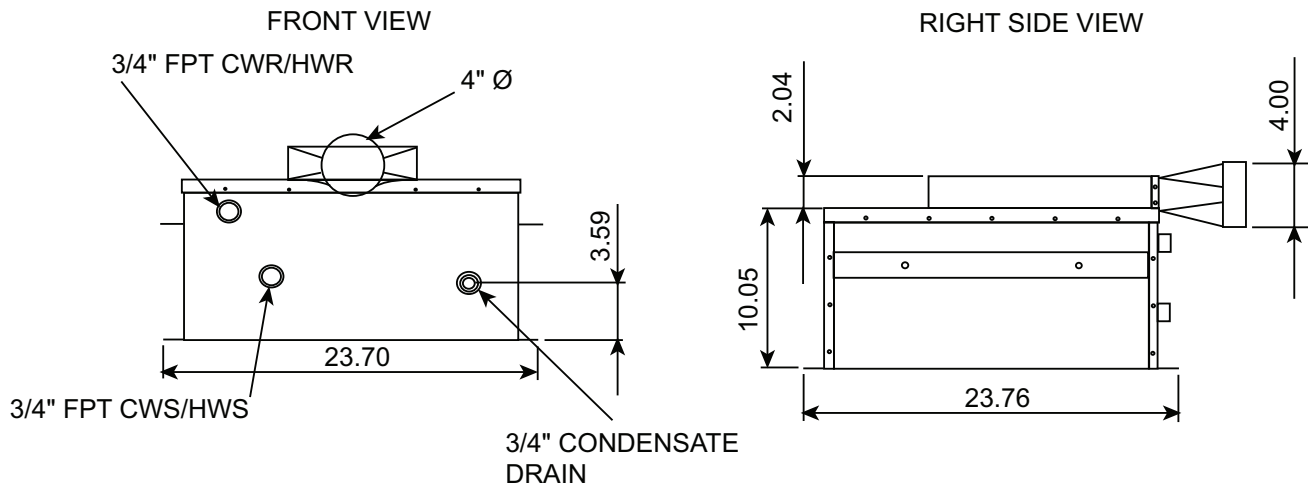

- LEGEND**
- CWR** — Chilled Water Return
 - CWS** — Chilled Water Supply
 - FPT** — Female Pipe Thread
 - HWR** — Hot Water Return
 - HWS** — Hot Water Supply

- NOTES:**
1. Dimensions shown in inches.
 2. Drawing shows 2-pipe arrangement.

Fig. 1 — 36IBAC 2 x 2, All-Way Blow, 2-Pipe Unit Dimensions

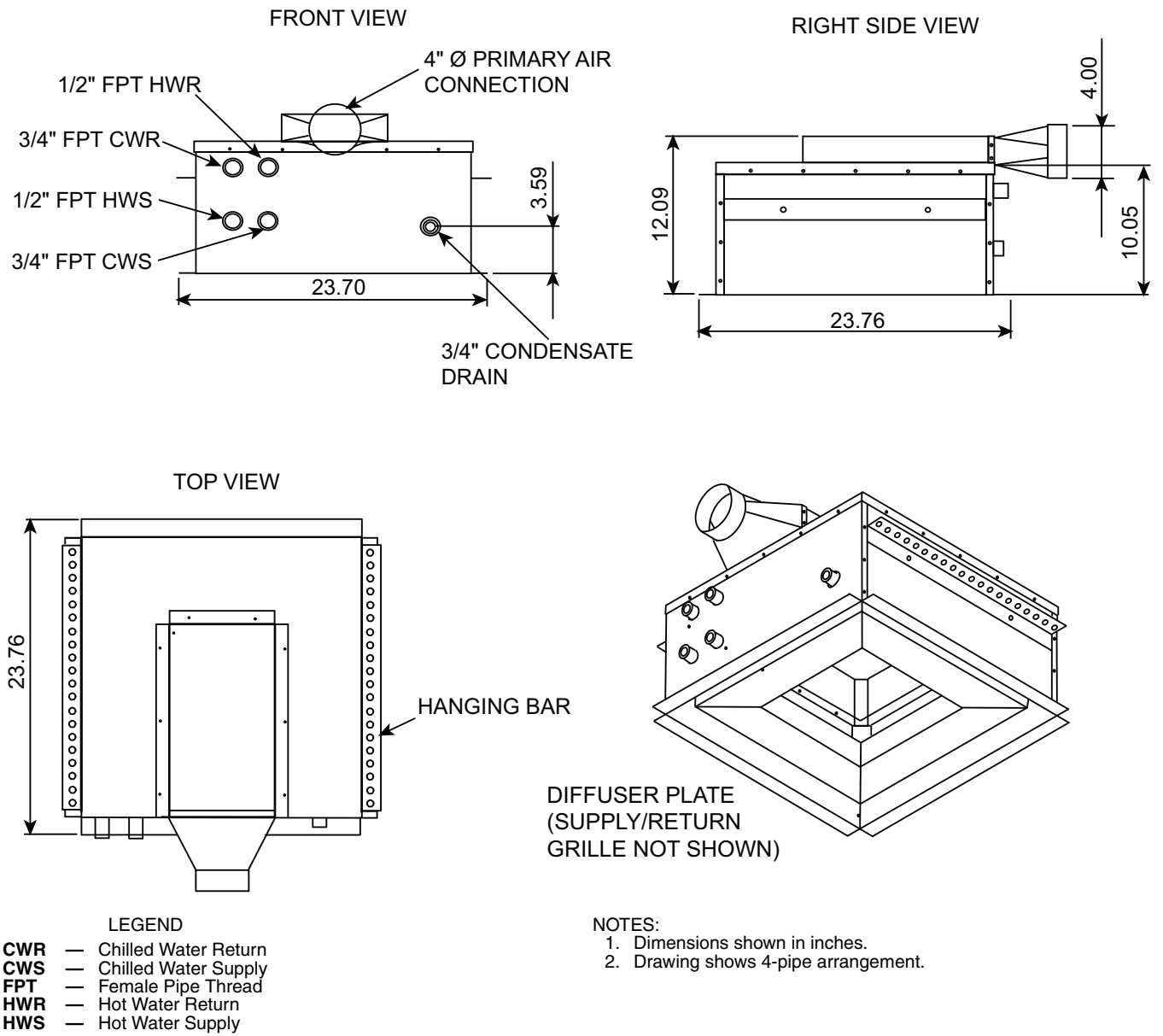
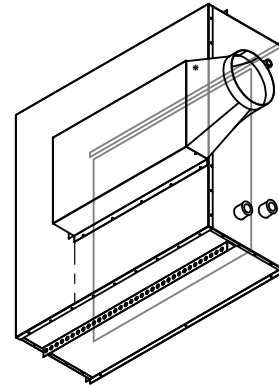
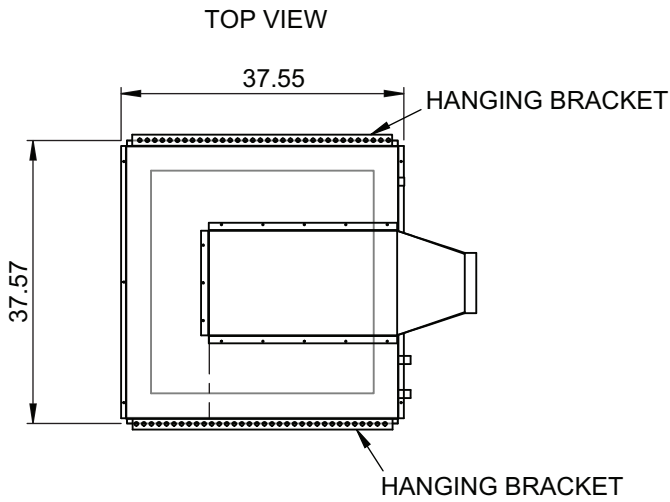
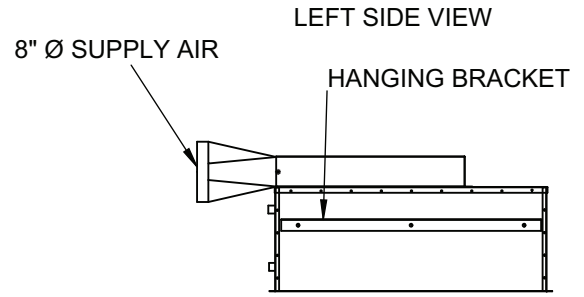
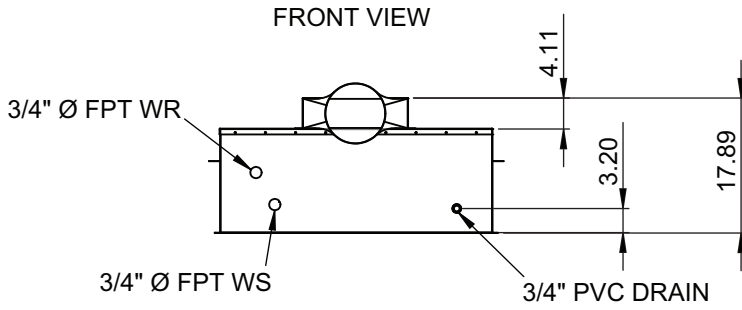

Fig. 2 — 36IBAC 2 x 2, All-Way Blow, 4-Pipe Unit Dimensions



LEGEND

FPT — Female Pipe Thread

WR — Water Return

WS — Water Supply

NOTES:

1. Dimensions shown in inches.
2. Drawing shows 2-pipe arrangement.

Fig. 3 — 36IBAC 4 x 4, All-Way Blow, 2-Pipe Unit Dimensions

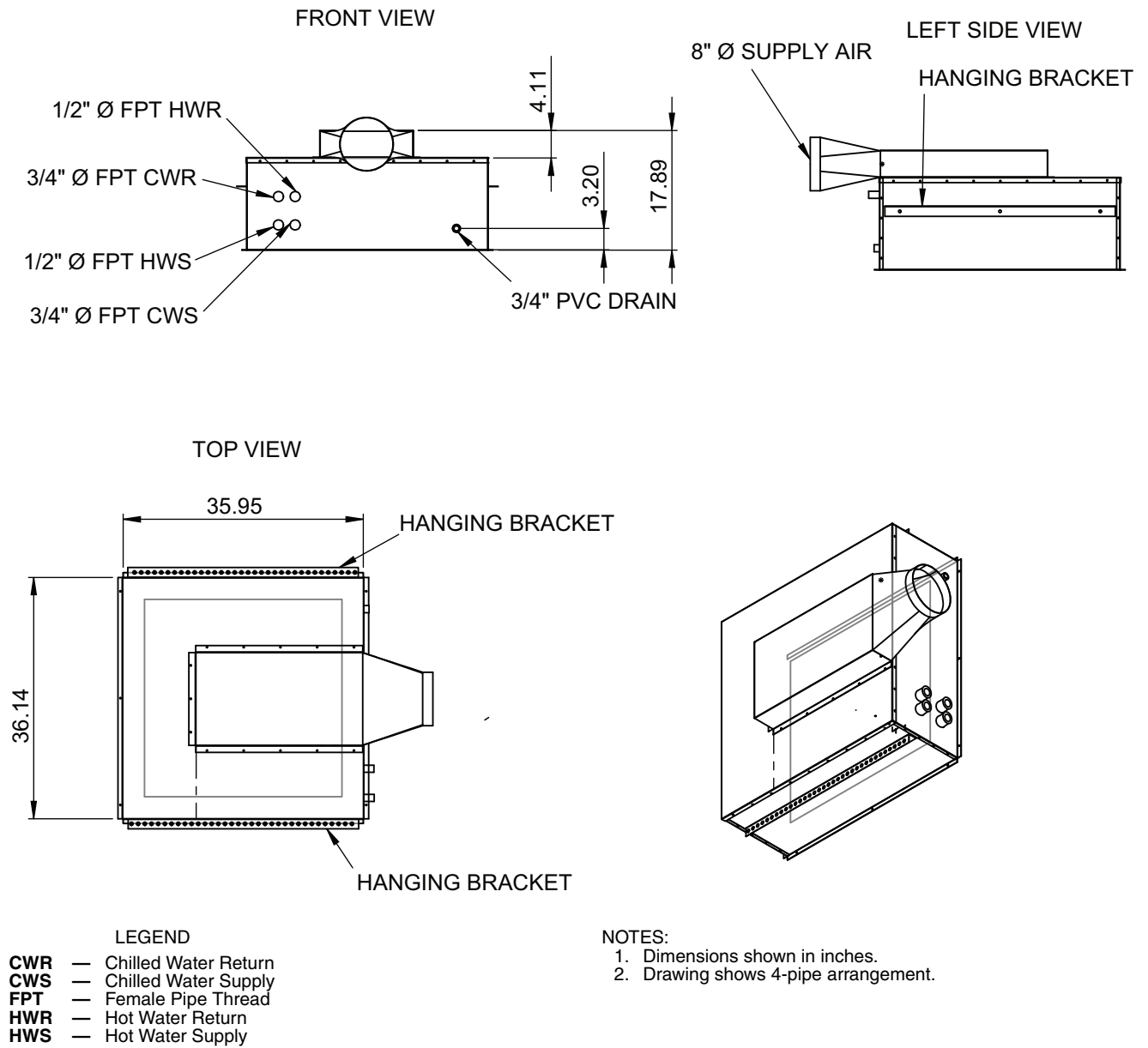
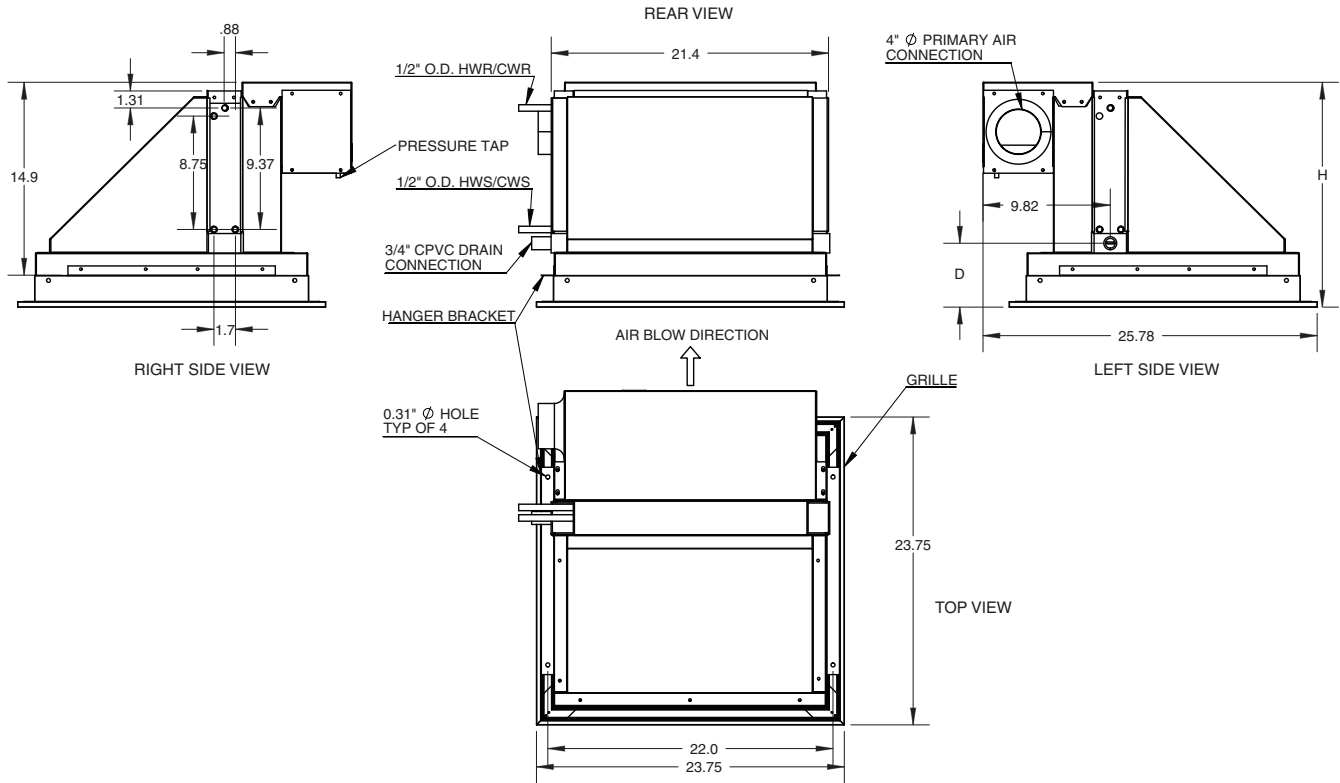

Fig. 4 — 36IBAC 4 x 4, All-Way Blow, 4-Pipe Unit Dimensions



LEGEND

CWR — Chilled Water Return
CWS — Chilled Water Supply
HWR — Hot Water Return
HWS — Hot Water Supply

NOTES:

1. Dimensions shown in inches.
2. Drawing shows 2-pipe arrangement, left-hand piping connection; right hand connection would be opposite.
3. Hand is determined by standing on the front side of the unit with the supply air blowing against the back of your head.
4. Front face of the unit is determined by the nozzle side (supply air) side of the unit.

Fig. 5 — 36IBAS 2 x 2, 1-Way Blow, 2-Pipe LH Unit Dimensions

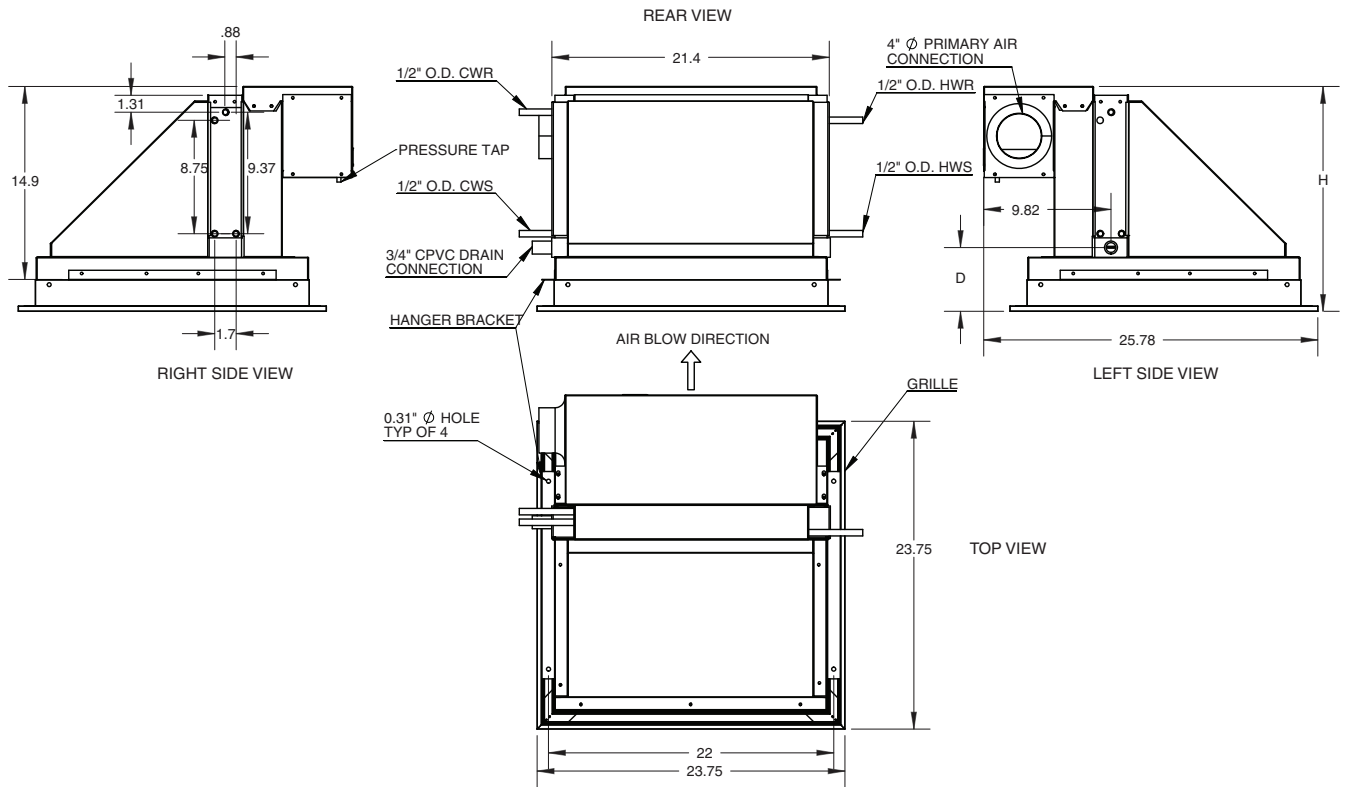

LEGEND

CWR — Chilled Water Return
CWS — Chilled Water Supply
HWR — Hot Water Return
HWS — Hot Water Supply

NOTES:

1. Dimensions shown in inches.
2. Drawing shows 4-pipe arrangement, left-hand piping connection; right hand connection would be opposite.
3. CW piping connection determines the hand of the unit.
4. Hand is determined by standing on the front side of the unit with the supply air blowing against the back of your head.
5. Front face of the unit is determined by the nozzle side (supply air) side of the unit.

Fig. 6 — 36IBAS 2 x 2, 1-Way Blow, 4-Pipe LH Unit Dimensions

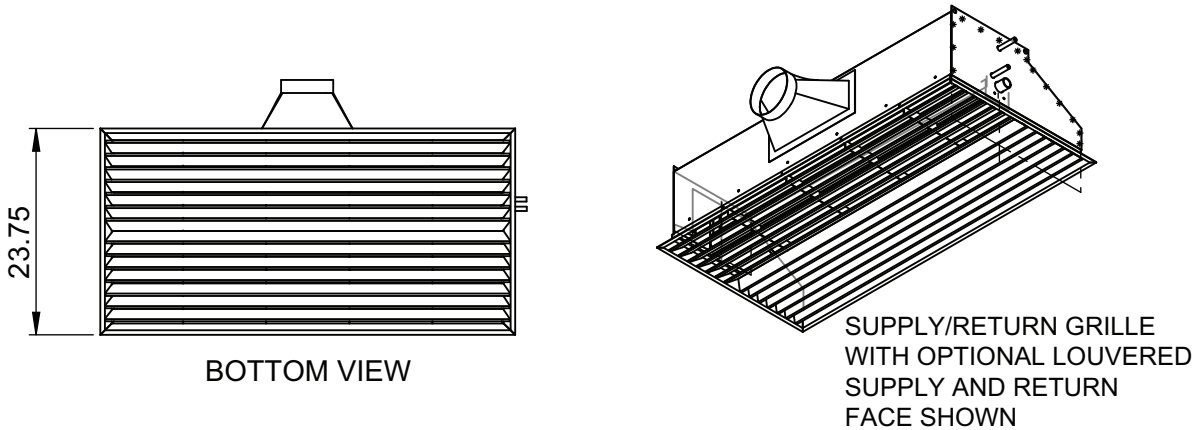
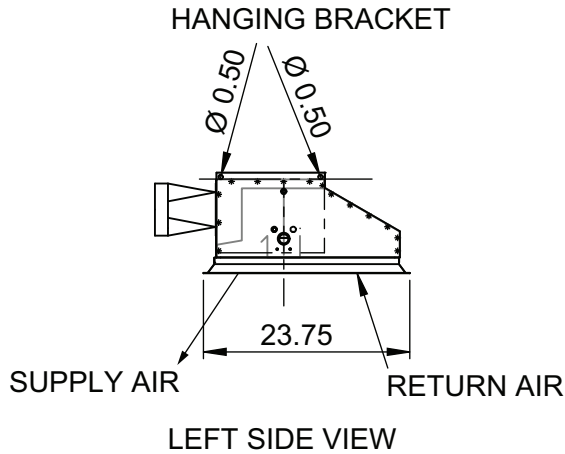
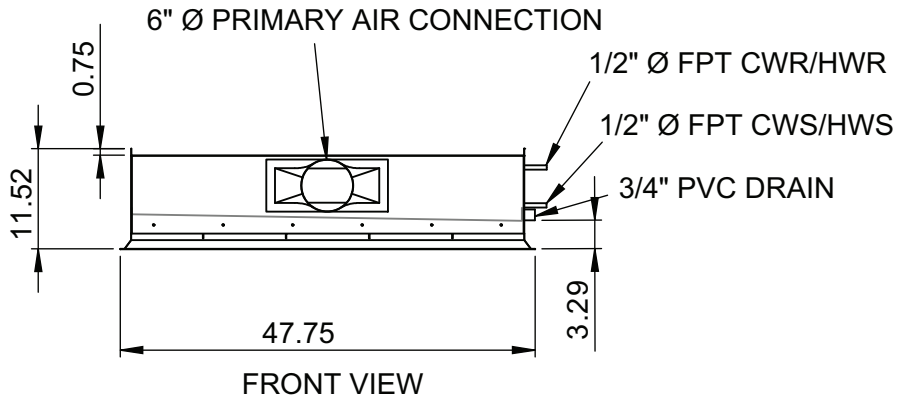

LEGEND

CWR	—	Chilled Water Return
CWS	—	Chilled Water Supply
FPT	—	Female Pipe Thread
HWR	—	Hot Water Return
HWS	—	Hot Water Supply

- NOTES:
1. Dimensions shown in inches.
 2. Drawing shows 2-pipe arrangement, left-hand piping connection; right hand connection would be opposite.
 3. CW piping connection determines the hand of the unit.
 4. Hand is determined by standing on the front side of the unit with the supply air blowing against the back of your head.
 5. Front face of the unit is determined by the nozzle side (supply air) side of the unit.

Fig. 7 — 36IBAN 2 x 4, 1-Way Blow, 2-Pipe LH Unit Dimensions

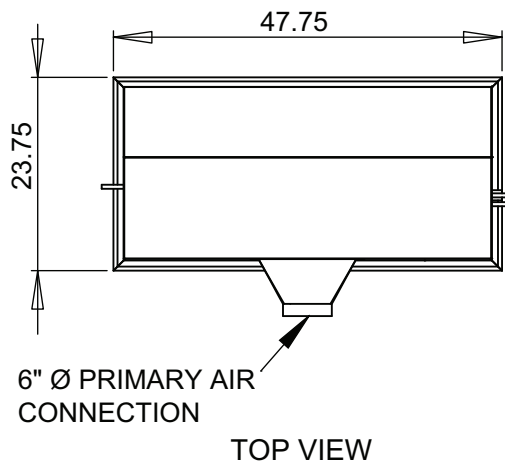
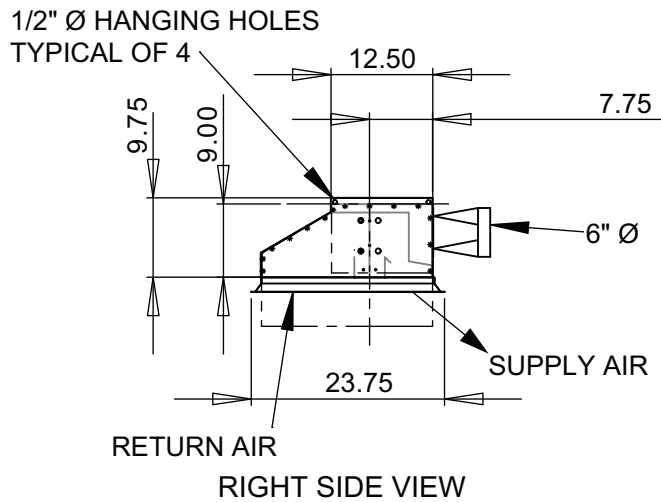
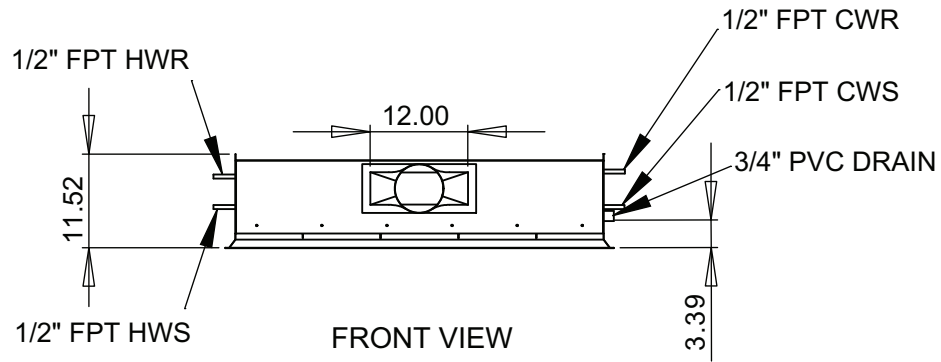

LEGEND

CWR	—	Chilled Water Return
CWS	—	Chilled Water Supply
FPT	—	Female Pipe Thread
HWR	—	Hot Water Return
HWS	—	Hot Water Supply

- NOTES:**
1. Dimensions shown in inches.
 2. Drawing shows 4-pipe arrangement, left-hand piping connection; right hand connection would be opposite.
 3. CW piping connection determines the hand of the unit.
 4. Hand is determined by standing on the front side of the unit with the supply air blowing against the back of your head.
 5. Front face of the unit is determined by the nozzle side (supply air) side of the unit.

Fig. 8 — 36IBAN 2 x 4, 1-Way Blow, 4-Pipe LH Unit Dimensions

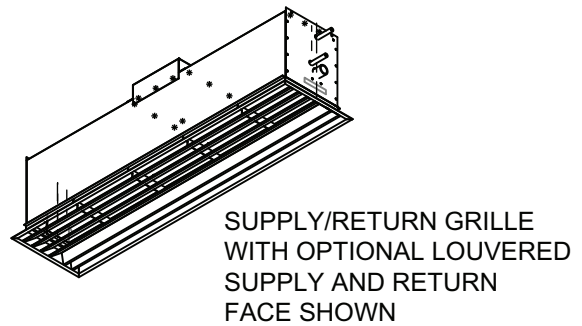
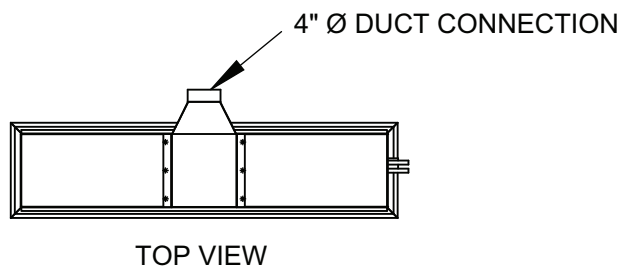
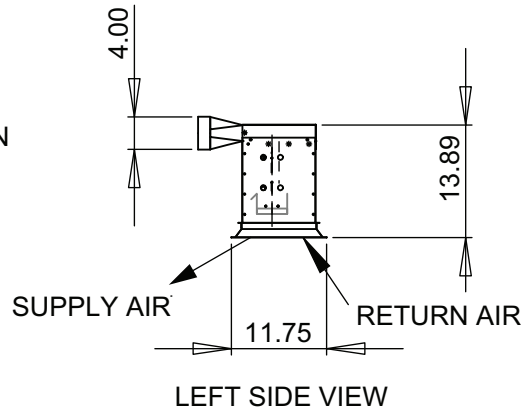
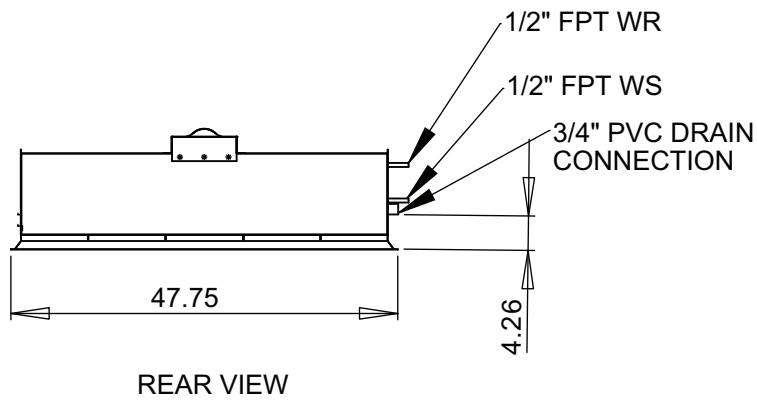

LEGEND

FPT	— Female Pipe Thread
WR	— Water Return
WS	— Water Supply

- NOTES:
1. Dimensions shown in inches.
 2. Drawing shows 2-pipe arrangement, right-hand piping connection; left hand connection would be opposite.
 3. Hand is determined by standing on the front side of the unit with the supply air blowing against the back of your head.
 4. Front face of the unit is determined by the nozzle side (supply air) side of the unit.

Fig. 9 — 36IBAN 1 x 4, 1-Way Blow, 2-Pipe RH Unit Dimensions

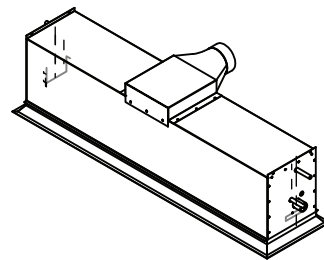
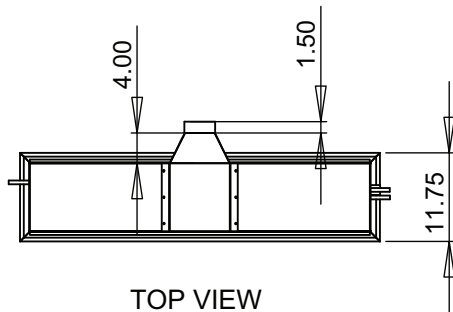
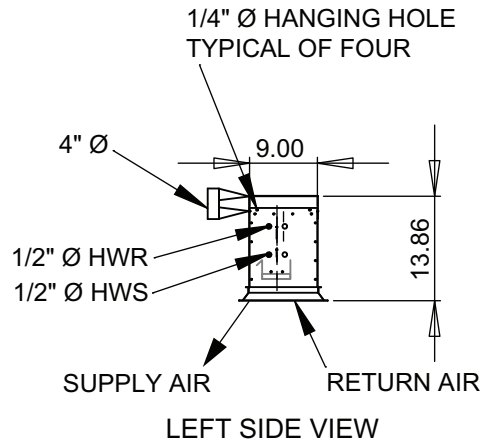
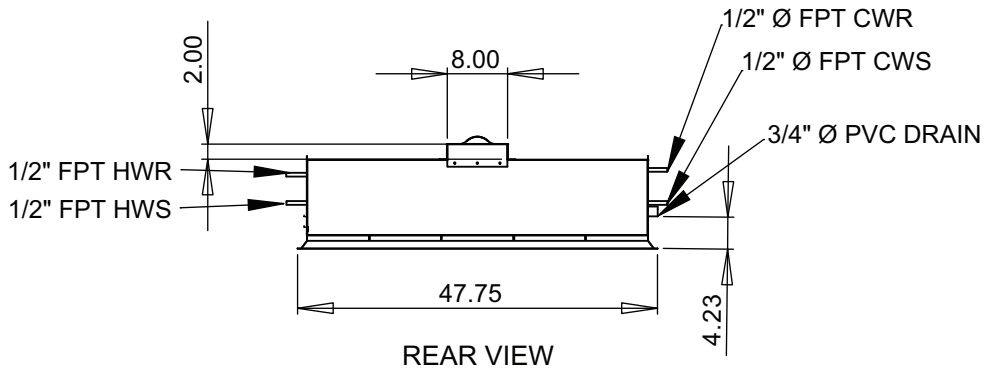

LEGEND

- CWR** — Chilled Water Return
- CWS** — Chilled Water Supply
- FPT** — Female Pipe Thread
- HWR** — Hot Water Return
- HWS** — Hot Water Supply

NOTES:

1. Dimensions shown in inches.
2. Drawing shows 4-pipe arrangement, right-hand piping connection; left hand connection would be opposite.
3. CW piping connection determines the hand of the unit.
4. Hand is determined by standing on the front side of the unit with the supply air blowing against the back of your head.
5. Front face of the unit is determined by the nozzle side (supply air) side of the unit.

Fig. 10 — 36IBAN 1 x 4, 1-Way Blow, 4-Pipe RH Unit Dimensions

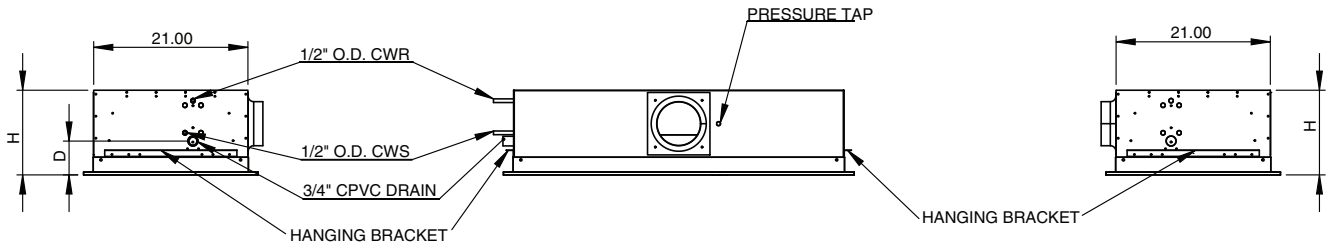
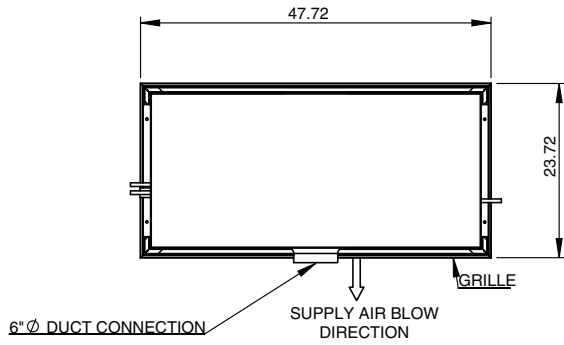

COLLARS	H DIMENSION (in.)	D DIMENSION (in.)
None	11.53	4.6
3 in.	14.53	7.6
4 in.	15.53	8.6
5 in.	16.53	9.6
6 in.	17.53	10.6

LEGEND
CWR — Chilled Water Return
CWS — Chilled Water Supply

- NOTES:
1. Dimensions shown in inches.
 2. Drawing shows 2-pipe arrangement, right-hand piping connection; left hand connection would be opposite.
 3. Hand is determined by standing on the front side of the unit with the supply air blowing against the back of your head.
 4. Front face of the unit is determined by the nozzle side (supply air) side of the unit.

Fig. 11 — 36IBAR 2 x 4, 1-Way Blow, 2-Pipe, RH Unit Dimensions

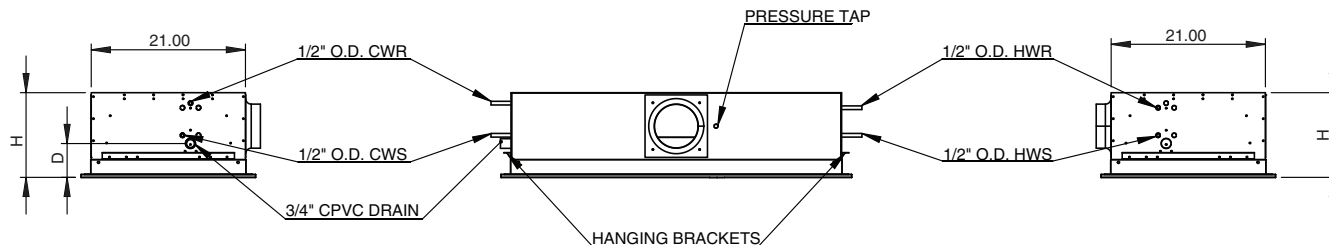
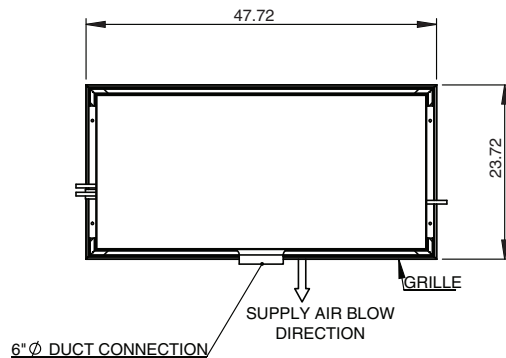

COLLARS	H DIMENSION (in.)	D DIMENSION (in.)
None	11.53	4.6
3 in.	14.53	7.6
4 in.	15.53	8.6
5 in.	16.53	9.6
6 in.	17.53	10.6

LEGEND

- CWR** — Chilled Water Return
- CWS** — Chilled Water Supply
- HWR** — Hot Water Return
- HWS** — Hot Water Supply

NOTES:

1. Dimensions shown in inches.
2. Drawing shows 4-pipe arrangement, right-hand piping connection; left hand connection would be opposite.
3. CW piping connection determines the hand of the unit.
4. Hand is determined by standing on the front side of the unit with the supply air blowing against the back of your head.
5. Front face of the unit is determined by the nozzle side (supply air) side of the unit.

Fig. 12 — 36IBAR 2 x 4, 1-Way Blow, 4-Pipe, RH Unit Dimensions

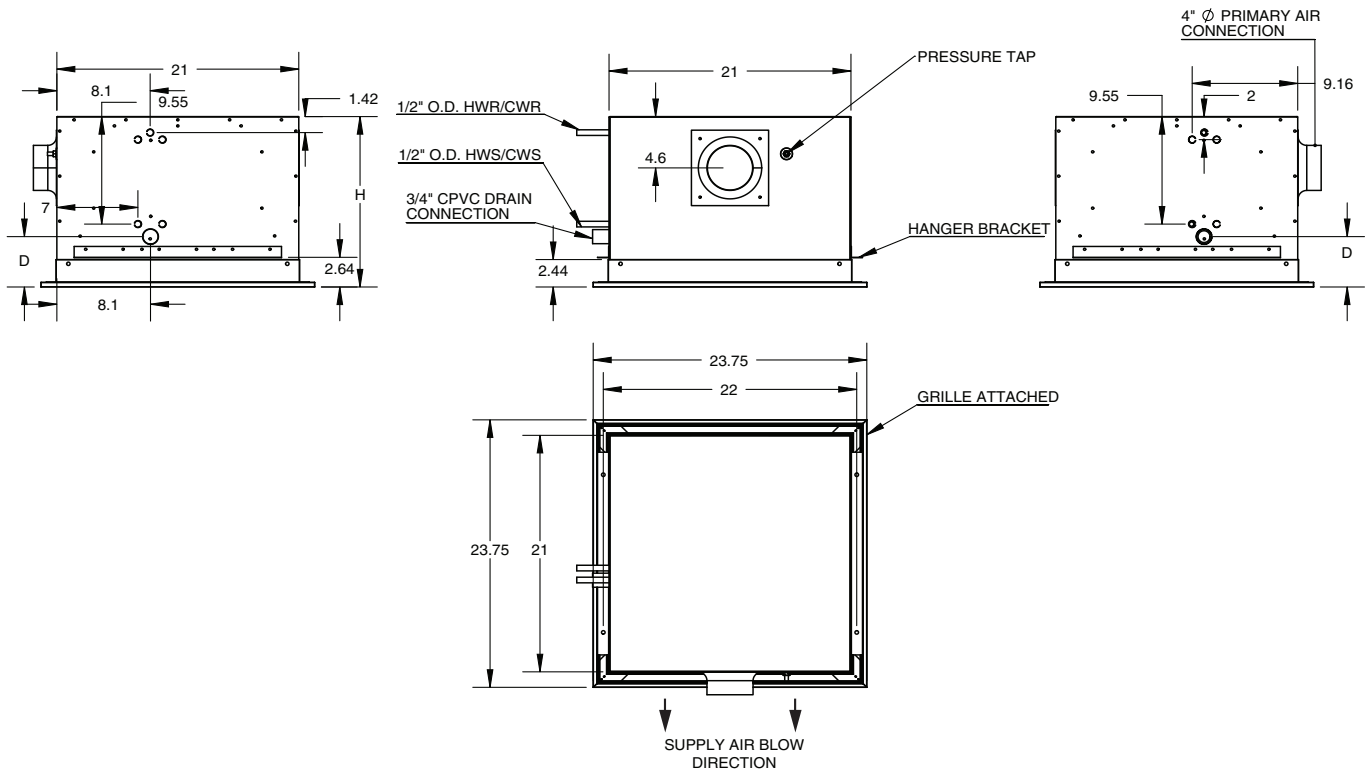

COLLARS	H DIMENSION (in.)	D DIMENSION (in.)
None	15.1	4.5
3 in.	18.1	7.5
4 in.	19.1	8.5
5 in.	20.1	9.5
6 in.	21.1	10.5

LEGEND

- CWR** — Chilled Water Return
- CWS** — Chilled Water Supply
- HWR** — Hot Water Return
- HWS** — Hot Water Supply

NOTES:

1. Dimensions shown in inches.
2. Drawing shows 2-pipe arrangement, right-hand piping connection; left hand connection would be opposite.
3. Hand is determined by standing on the front side of the unit with the supply air blowing against the back of your head.
4. Front face of the unit is determined by the nozzle side (supply air) side of the unit.

Fig. 13 — 36IBAM 2 x 2, 1-Way Blow, 2-Pipe, RH Unit Dimensions

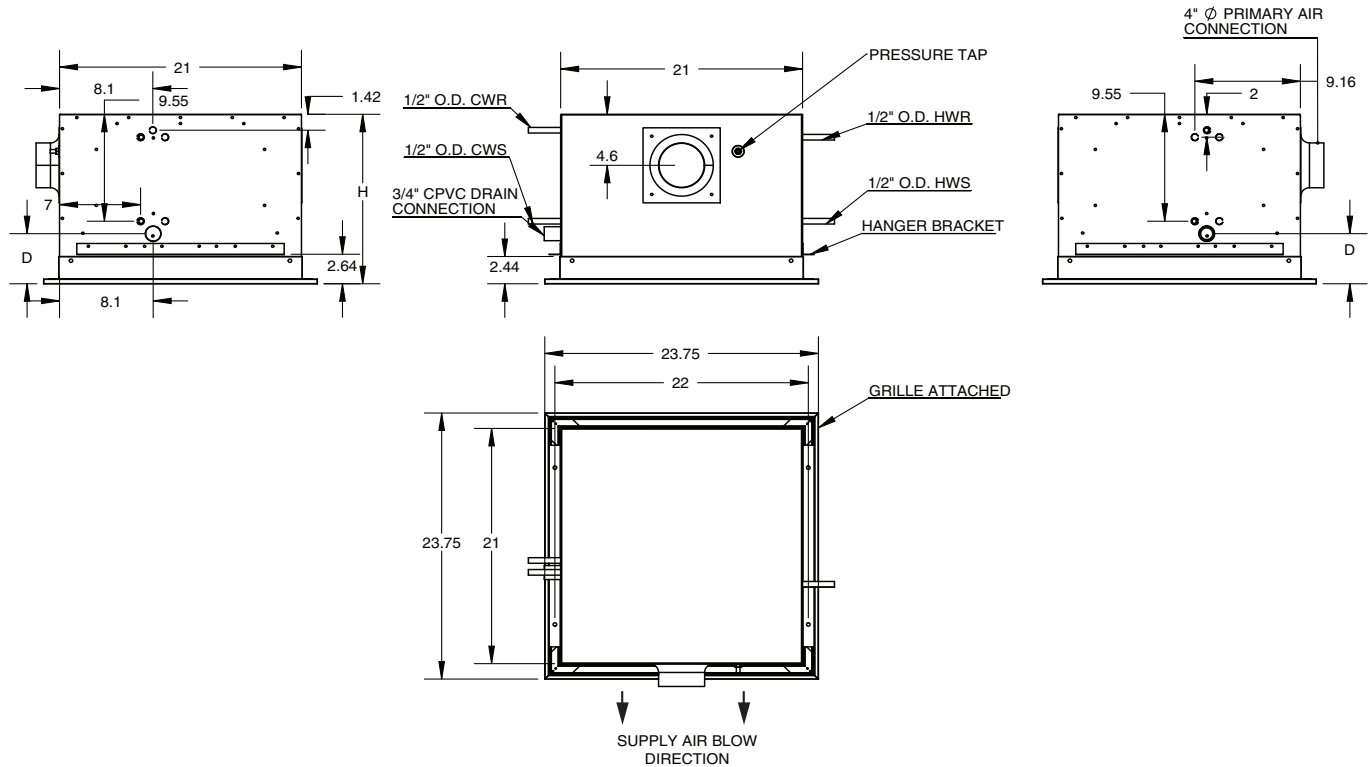

COLLARS	H DIMENSION (in.)	D DIMENSION (in.)
None	15.1	4.5
3 in.	18.1	7.5
4 in.	19.1	8.5
5 in.	20.1	9.5
6 in.	21.1	10.5

LEGEND
CWR — Chilled Water Return
CWS — Chilled Water Supply
HWR — Hot Water Return
HWS — Hot Water Supply

- NOTES:
1. Dimensions shown in inches.
 2. Drawing shows 4-pipe arrangement, right-hand piping connection; left hand connection would be opposite.
 3. CW piping connection determines the hand of the unit.
 4. Hand is determined by standing on the front side of the unit with the supply air blowing against the back of your head.
 5. Front face of the unit is determined by the nozzle side (supply air) side of the unit.

Fig. 14 — 36IBAM 2 x 2, 1-Way Blow, 4-Pipe, RH Unit Dimensions

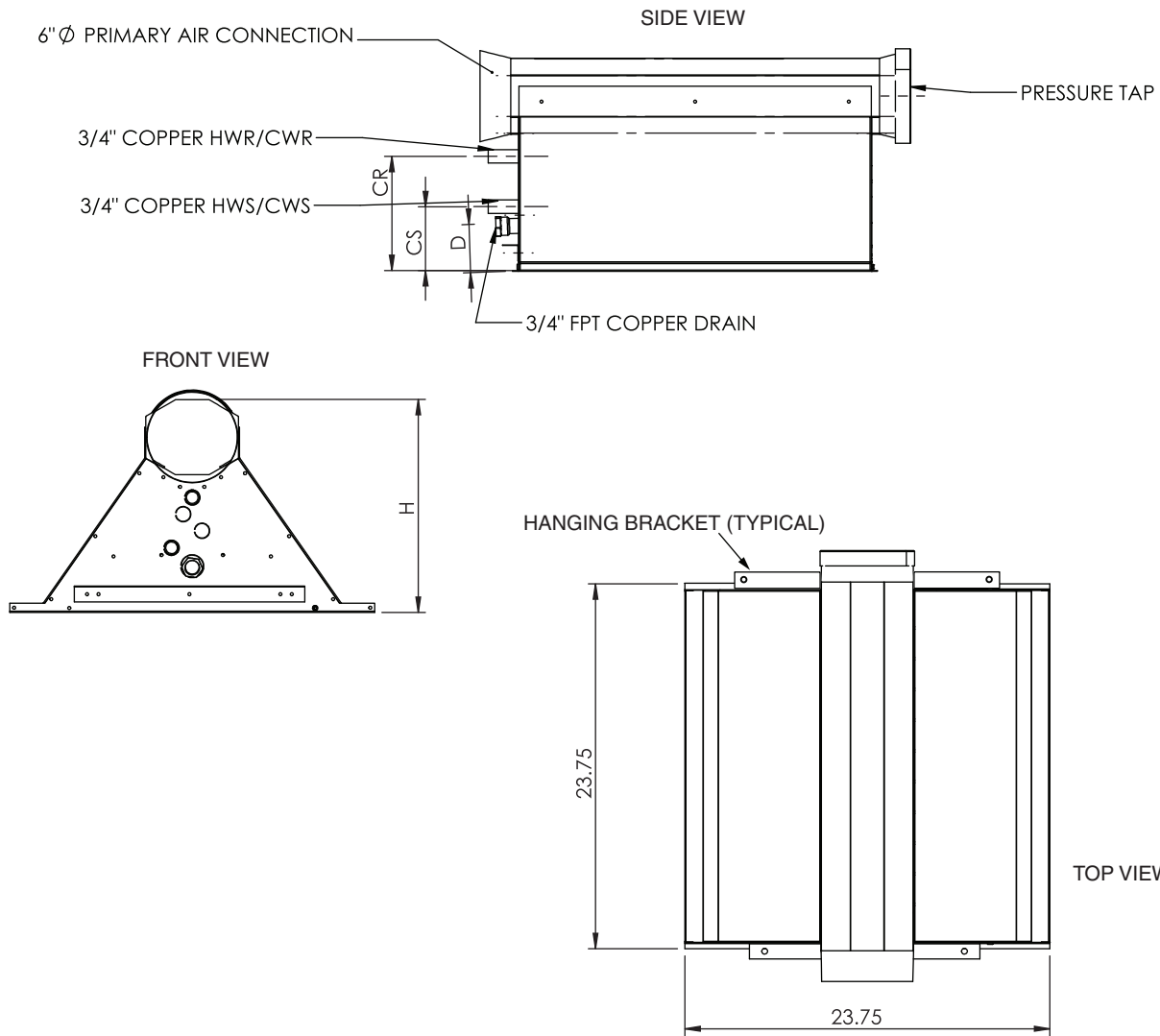

DIMENSION	H (in.)	D (in.)	CS	CR
Standard	14	3.15	4.15	7.5
Extended Version	17	6.15	7.15	10.5

LEGEND

- CWR** — Chilled Water Return
- CWS** — Chilled Water Supply
- HWR** — Hot Water Return
- HWS** — Hot Water Supply

NOTE: Dimensions shown in inches.

Fig. 15 — 36IBAL 2 x 2, 2-Way Blow, 2-Pipe Unit Dimensions

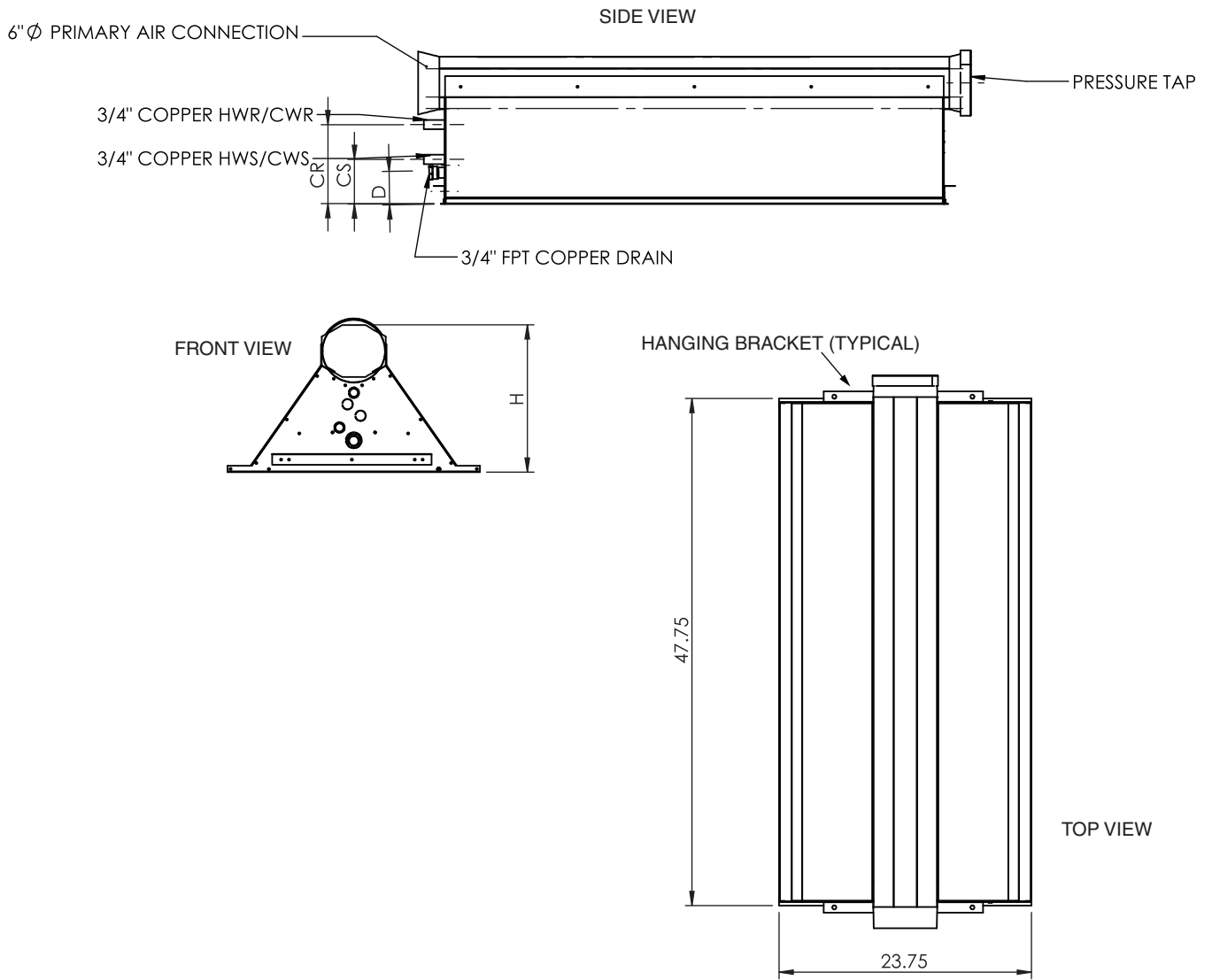

DIMENSION	H (in.)	D (in.)	CS	CR
Standard	14	3.15	4.15	7.5
Extended Version	17	6.15	7.15	10.5

LEGEND

- CWR** — Chilled Water Return
- CWS** — Chilled Water Supply
- HWR** — Hot Water Return
- HWS** — Hot Water Supply

NOTE: Dimensions shown in inches.

Fig. 16 — 36IBAL 4 x 2, 2-Way Blow, 2-Pipe Unit Dimensions

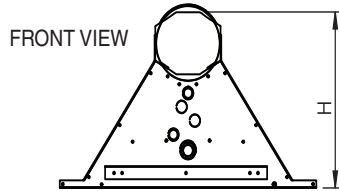
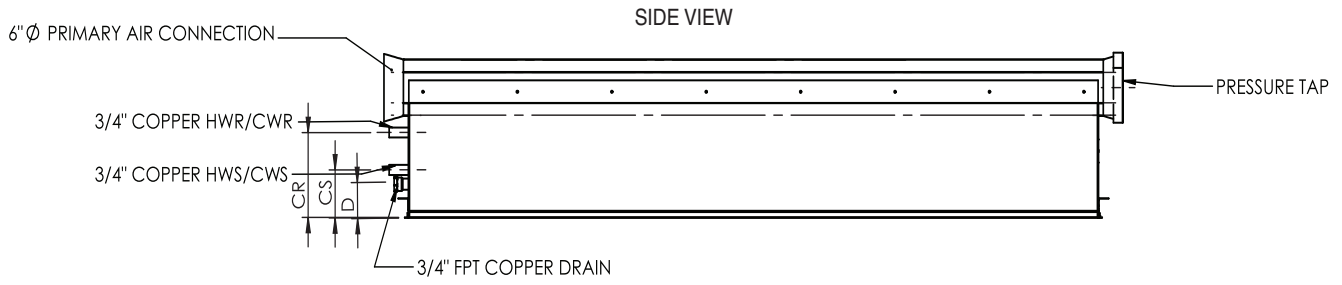

HANGING BRACKET (TYPICAL)

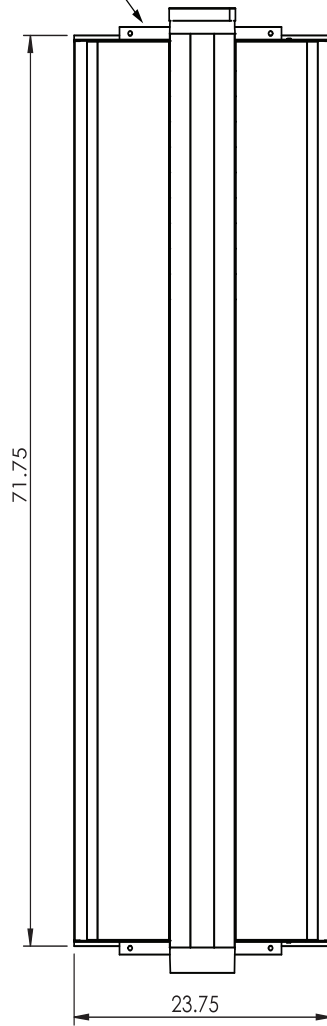

TOP VIEW

DIMENSION	H (in.)	D (in.)	CS	CR
Standard	14	3.15	4.15	7.5
Extended Version	17	6.15	7.15	10.5

LEGEND

- CWR** — Chilled Water Return
- CWS** — Chilled Water Supply
- HWR** — Hot Water Return
- HWS** — Hot Water Supply

NOTE: Dimensions shown in inches.

Fig. 17 — 36IBAL 6 x 2, 2-Way Blow, 2-Pipe Unit Dimensions

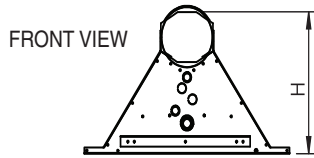
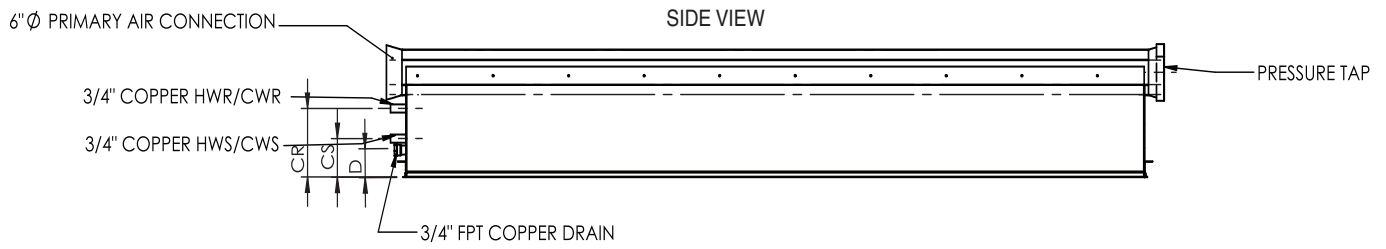

HANGING BRACKET (TYPICAL)

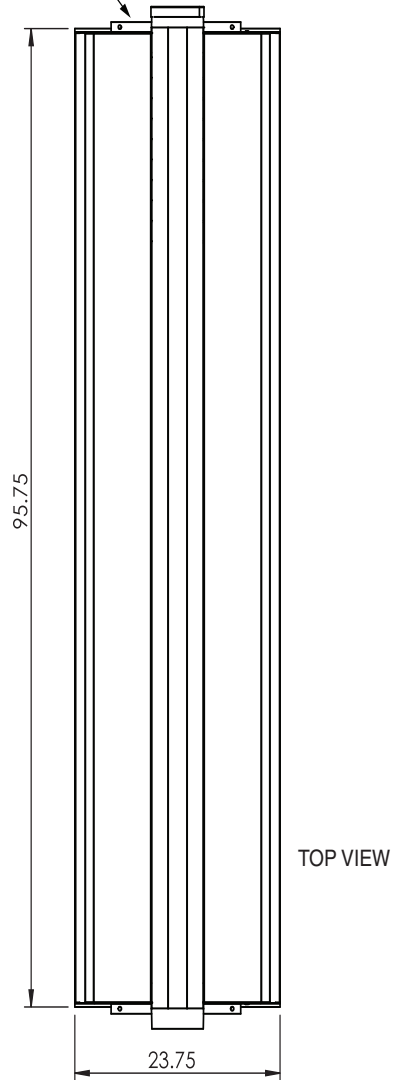

DIMENSION	H (in.)	D (in.)	CS	CR
Standard	14	3.15	4.15	7.5
Extended Version	17	6.15	7.15	10.5

LEGEND

- CWR** — Chilled Water Return
- CWS** — Chilled Water Supply
- HWR** — Hot Water Return
- HWS** — Hot Water Supply

NOTE: Dimensions shown in inches.

Fig. 18 — 36IBAL 8 x 2, 2-Way Blow, 2-Pipe Unit Dimensions

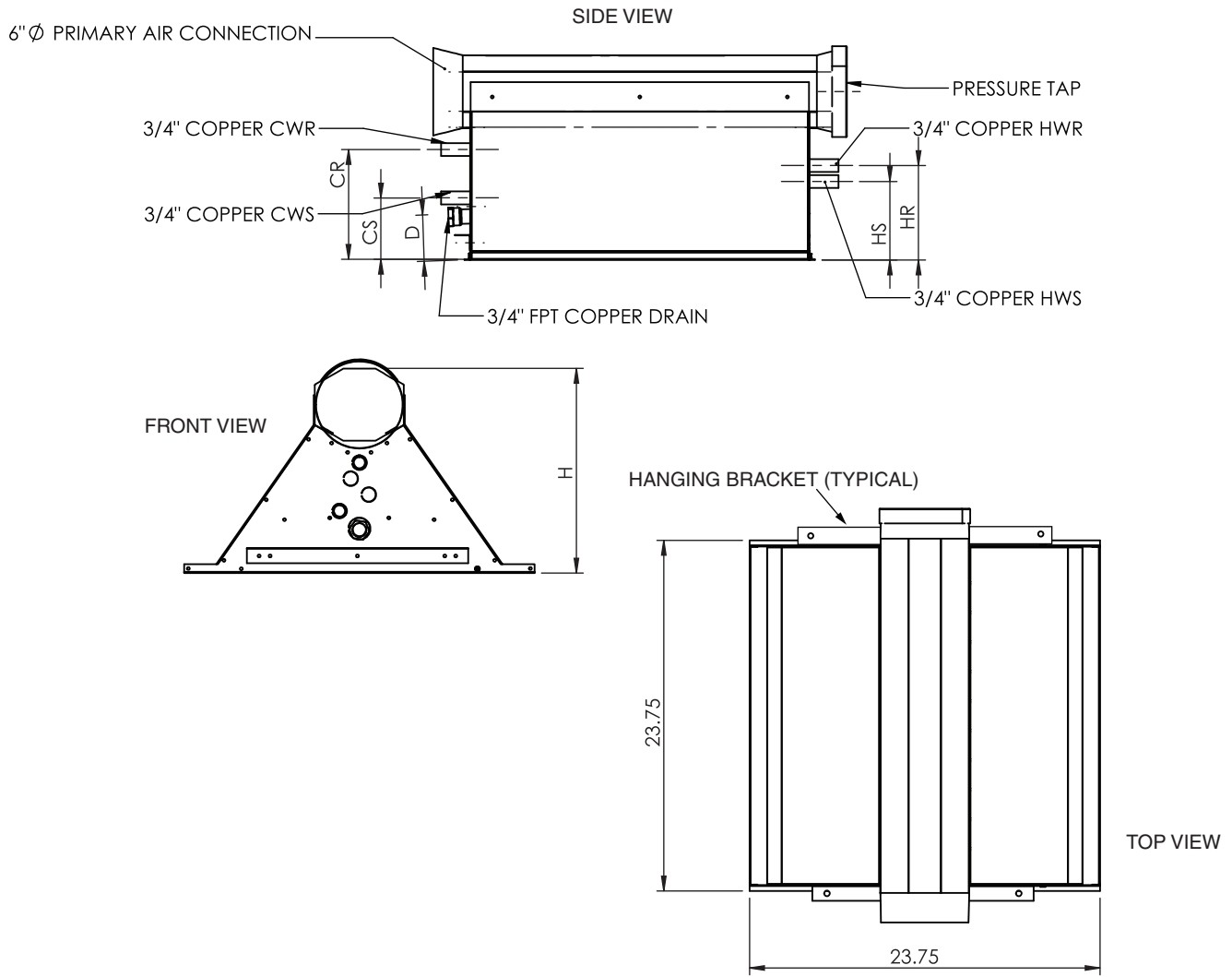

DIMENSION	H (in.)	D (in.)	CS (in.)	CR (in.)	HS (in.)	HR (in.)
Standard	14	3.15	4.15	7.5	5.3	6.4
Extended Version	17	6.15	7.15	10.5	8.3	9.4

LEGEND

- CWR** — Chilled Water Return
- CWS** — Chilled Water Supply
- HWR** — Hot Water Return
- HWS** — Hot Water Supply

NOTE: Dimensions shown in inches.

Fig. 19 — 36IBAL 2 x 2, 2-Way Blow, 4-Pipe Unit Dimensions

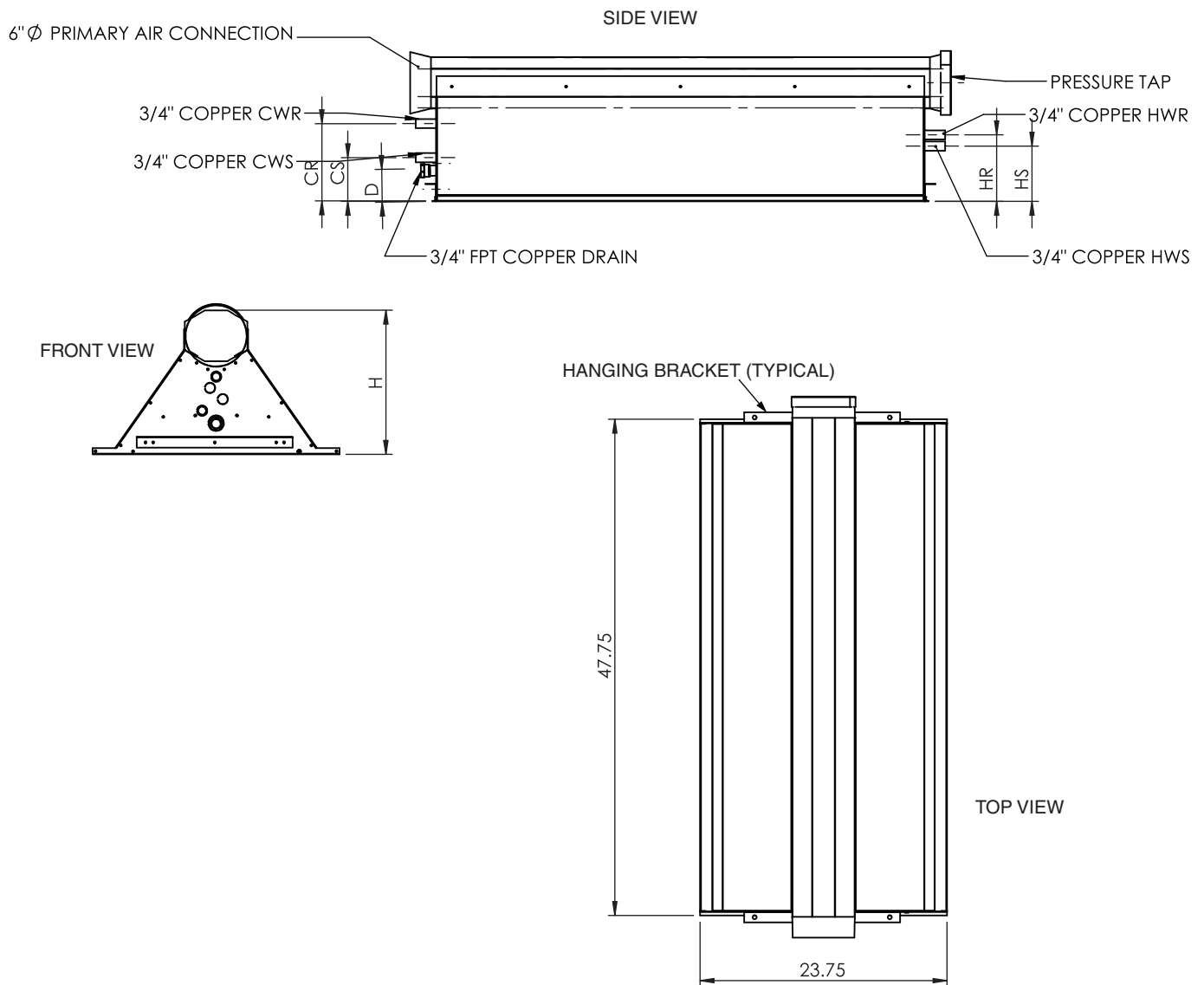

DIMENSION	H (in.)	D (in.)	CS (in.)	CR (in.)	HS (in.)	HR (in.)
Standard	14	3.15	4.15	7.5	5.3	6.4
Extended Version	17	6.15	7.15	10.5	8.3	9.4

LEGEND

- CWR** — Chilled Water Return
- CWS** — Chilled Water Supply
- HWR** — Hot Water Return
- HWS** — Hot Water Supply

NOTE: Dimensions shown in inches.

Fig. 20 — 36IBAL 4 x 2, 2-Way Blow, 4-Pipe Unit Dimensions

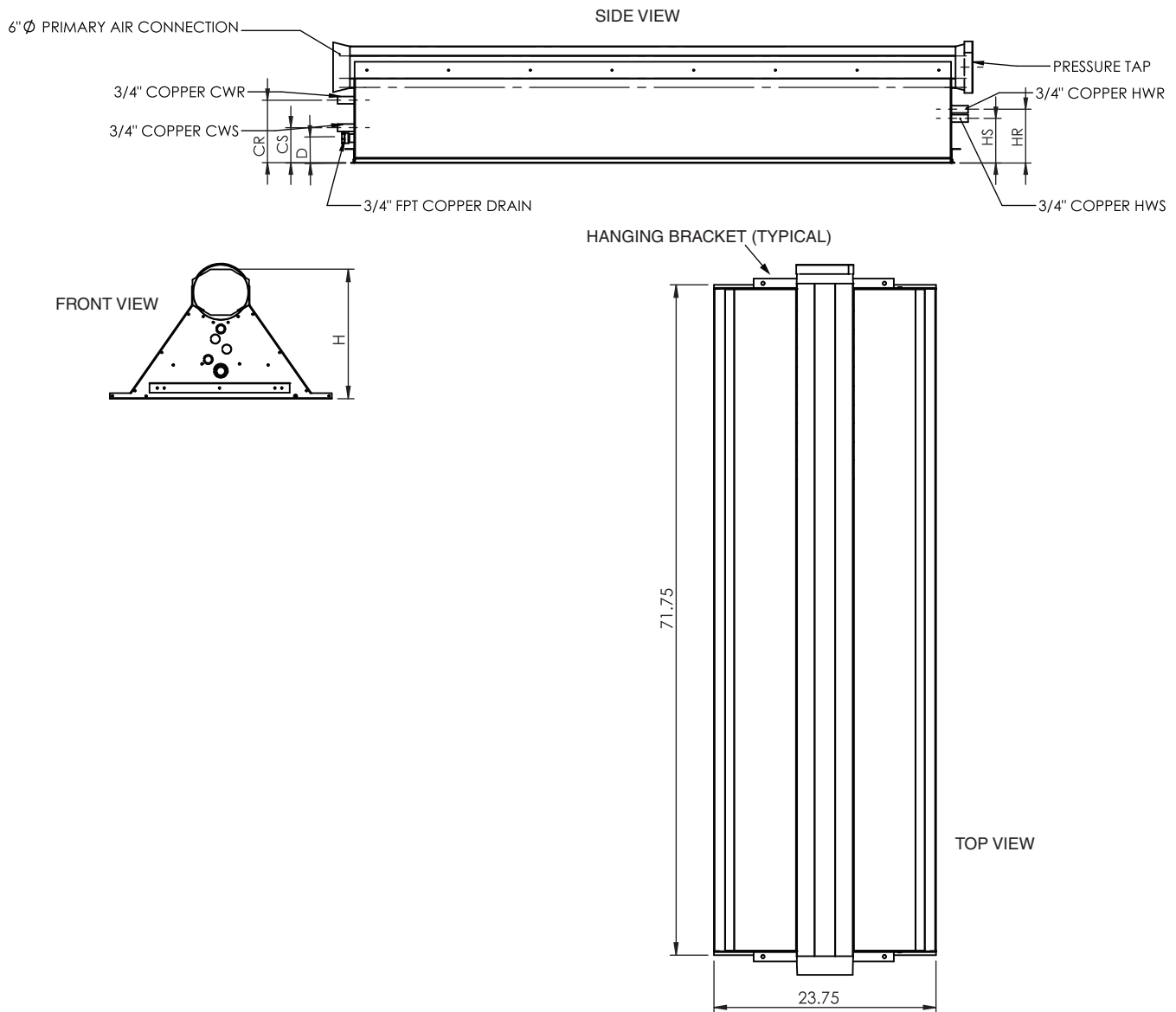

DIMENSION	H (in.)	D (in.)	CS (in.)	CR (in.)	HS (in.)	HR (in.)
Standard	14	3.15	4.15	7.5	5.3	6.4
Extended Version	17	6.15	7.15	10.5	8.3	9.4

LEGEND

- CWR** — Chilled Water Return
- CWS** — Chilled Water Supply
- HWR** — Hot Water Return
- HWS** — Hot Water Supply

NOTE: Dimensions shown in inches.

Fig. 21 — 36IBAL 6 x 2, 2-Way Blow, 4-Pipe Unit Dimensions

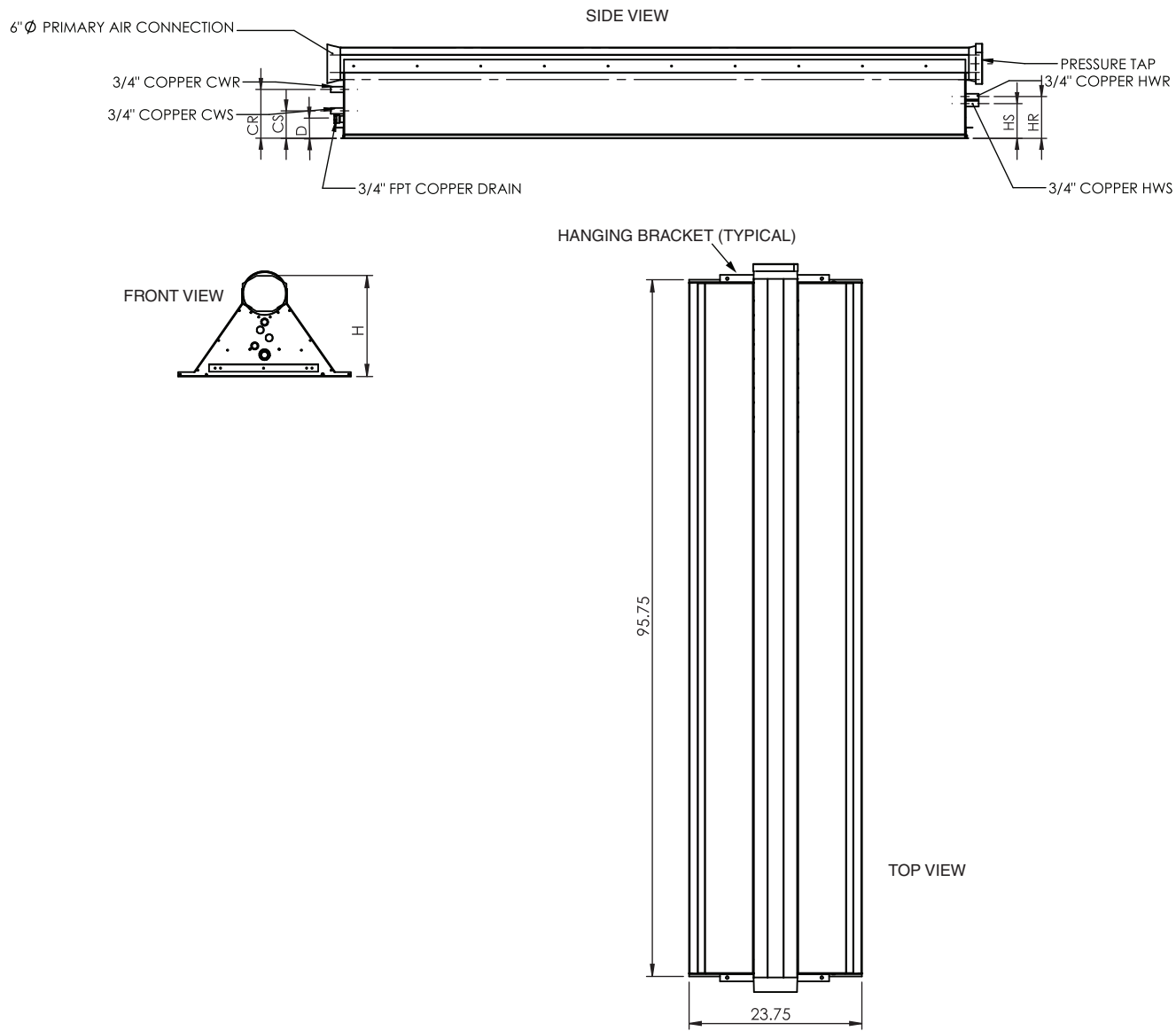

DIMENSION	H (in.)	D (in.)	CS (in.)	CR (in.)	HS (in.)	HR (in.)
Standard	14	3.15	4.15	7.5	5.3	6.4
Extended Version	17	6.15	7.15	10.5	8.3	9.4

- LEGEND
- CWR — Chilled Water Return
 - CWS — Chilled Water Supply
 - HWR — Hot Water Return
 - HWS — Hot Water Supply

NOTE: Dimensions shown in inches.

Fig. 22 — 36IBAL 8 x 2, 2-Way Blow, 4-Pipe Unit Dimensions

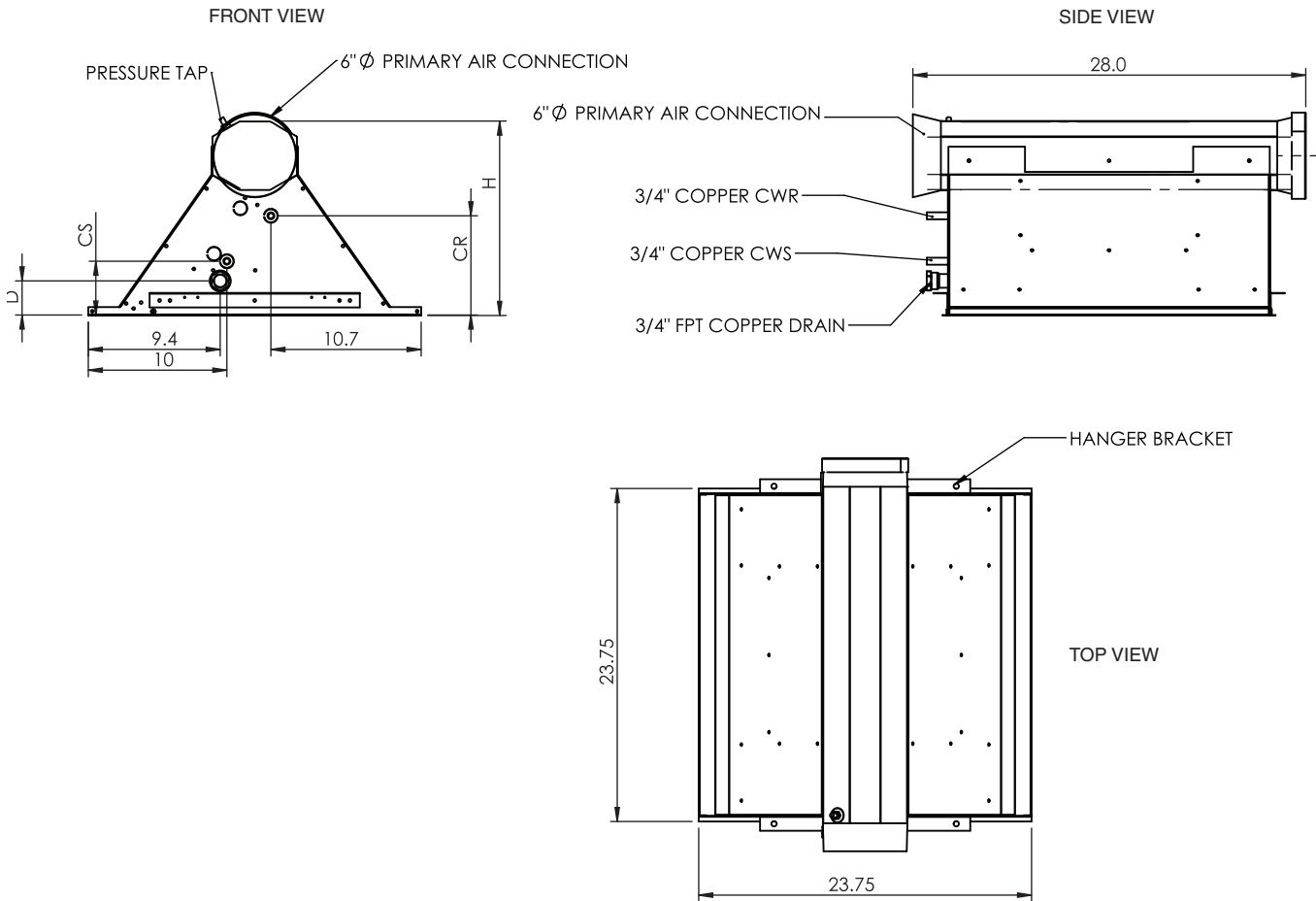

DIMENSION	H (in.)	D (in.)	CS (in.)	CR (in.)
Standard	14	2.6	4	7.25
Extended Version	17	5.6	7	10.25

LEGEND

- CWR** — Chilled Water Return
- CWS** — Chilled Water Supply

NOTE: Dimensions shown in inches.

Fig. 23 — 36IBAJ 2 x 2, 1-Way Blow, 2-Pipe Unit Dimensions

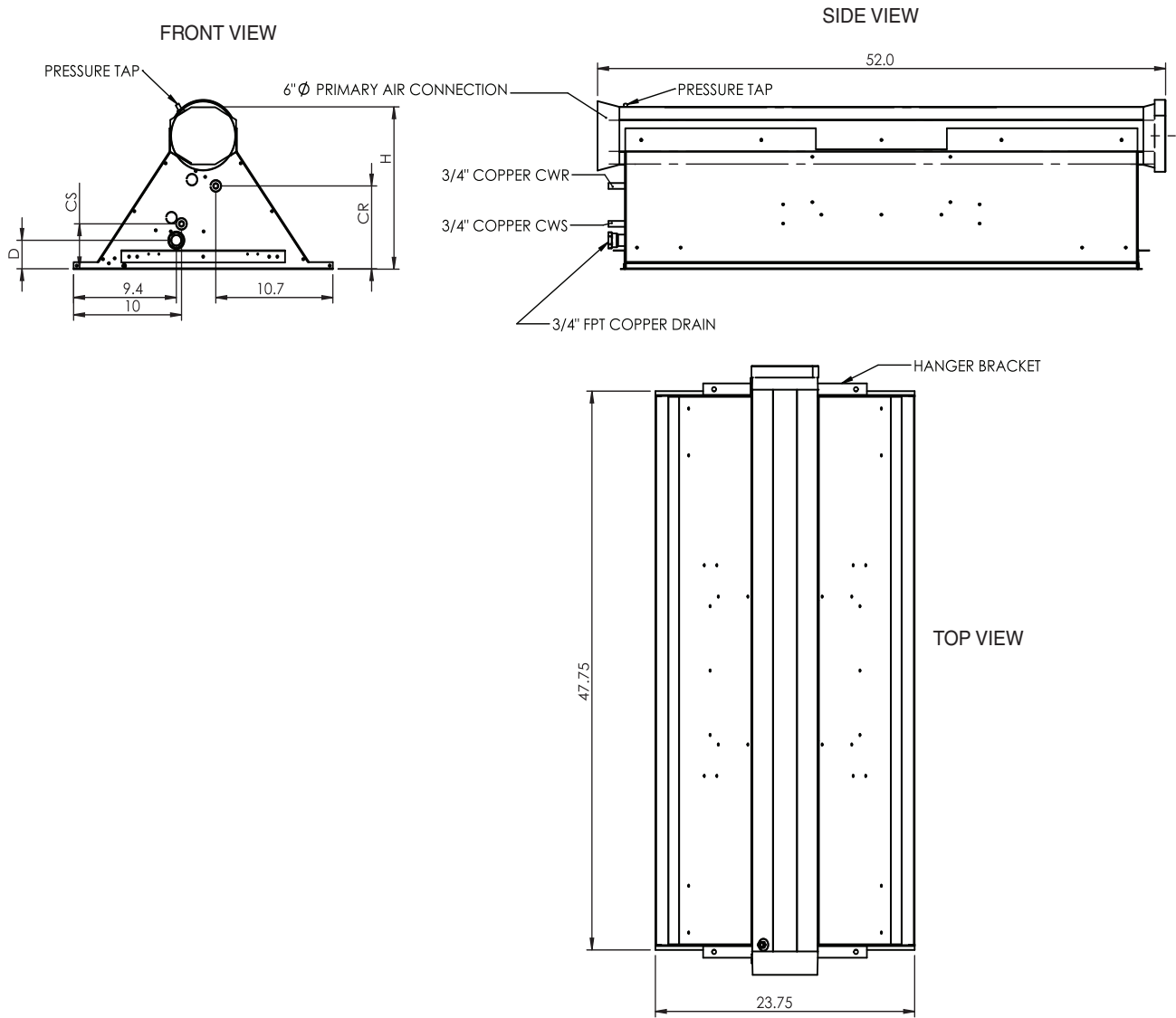

DIMENSION	H (in.)	D (in.)	CS (in.)	CR (in.)
Standard	14	2.6	4	7.25
Extended Version	17	5.6	7	10.25

LEGEND

CWR — Chilled Water Return
CWS — Chilled Water Supply

NOTE: Dimensions shown in inches.

Fig. 24 — 36IBAJ 4 x 2, 1-Way Blow, 2-Pipe Unit Dimensions

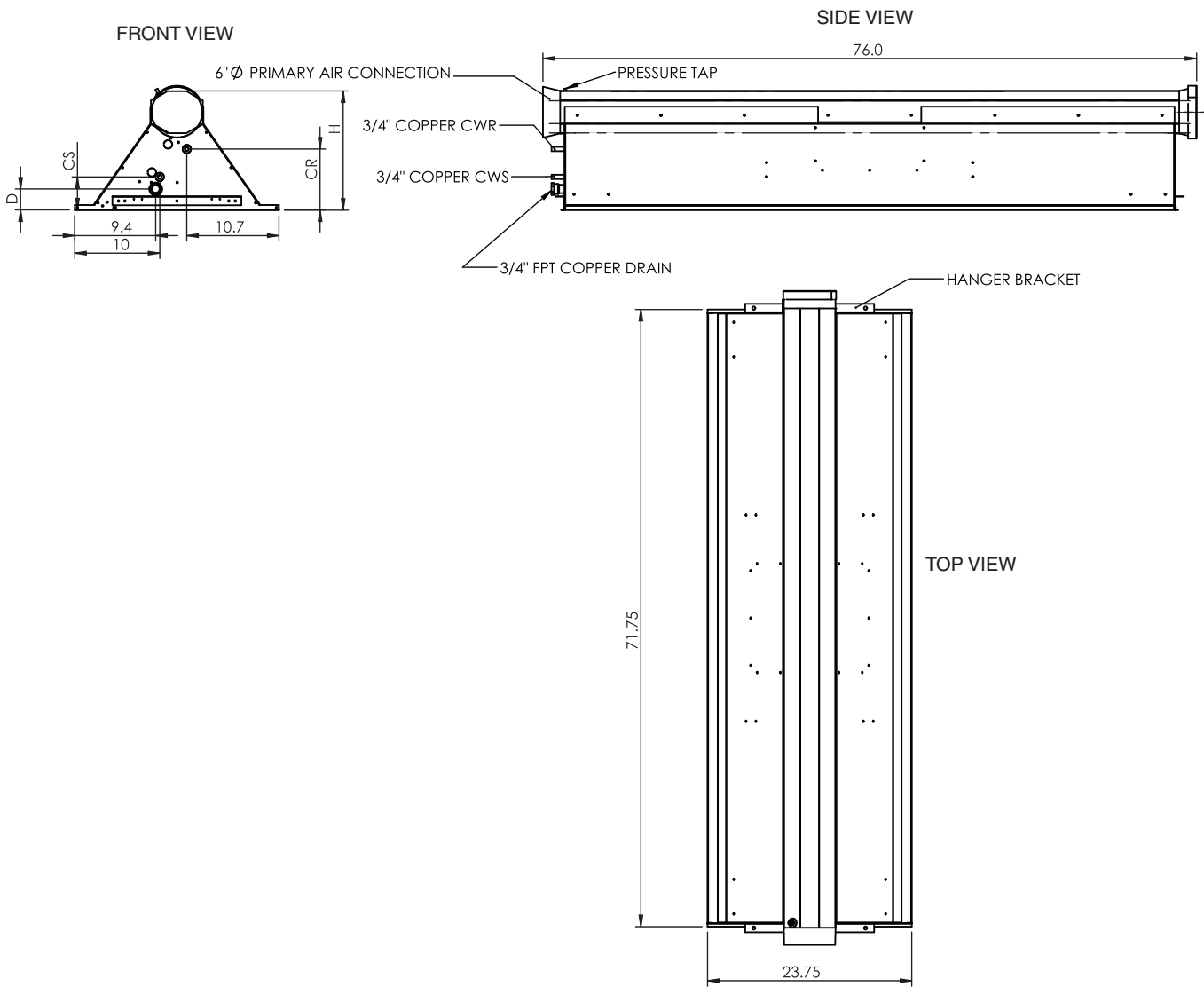

DIMENSION	H (in.)	D (in.)	CS (in.)	CR (in.)
Standard	14	2.6	4	7.25
Extended Version	17	5.6	7	10.25

LEGEND

CWR — Chilled Water Return
CWS — Chilled Water Supply

NOTE: Dimensions shown in inches.

Fig. 25 — 36IBAJ 6 x 2, 1-Way Blow, 2-Pipe Unit Dimensions

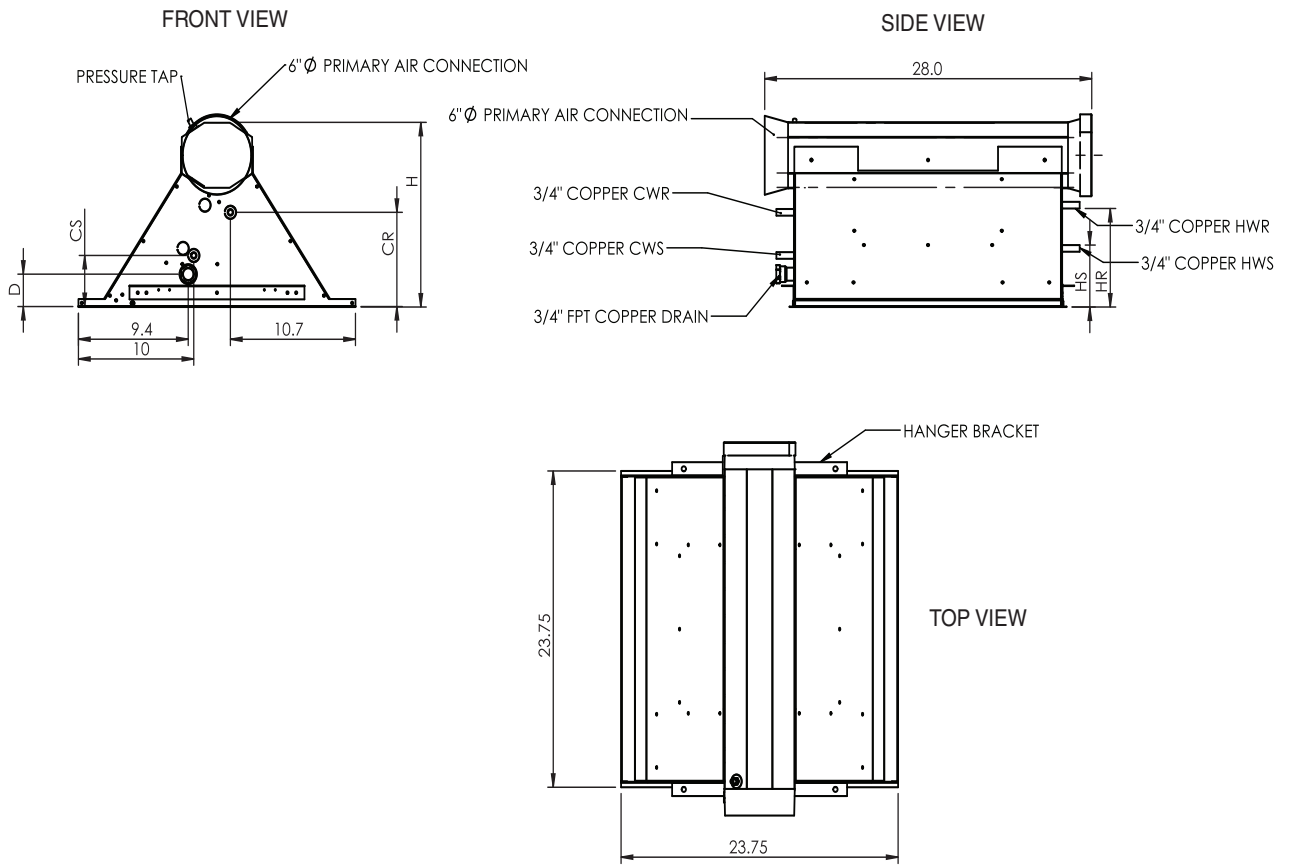

DIMENSION	H (in.)	D (in.)	CS (in.)	CR (in.)	HS (in.)	HR (in.)
Standard	14	2.6	4	7.25	4.85	7.6
Extended Version	17	5.6	7	10.25	7.85	10.6

LEGEND

- CWR** — Chilled Water Return
- CWS** — Chilled Water Supply
- HWR** — Hot Water Return
- HWS** — Hot Water Supply

NOTE: Dimensions shown in inches.

Fig. 26 — 36IBAJ 2 x 2, 1-Way Blow, 4-Pipe Unit Dimensions

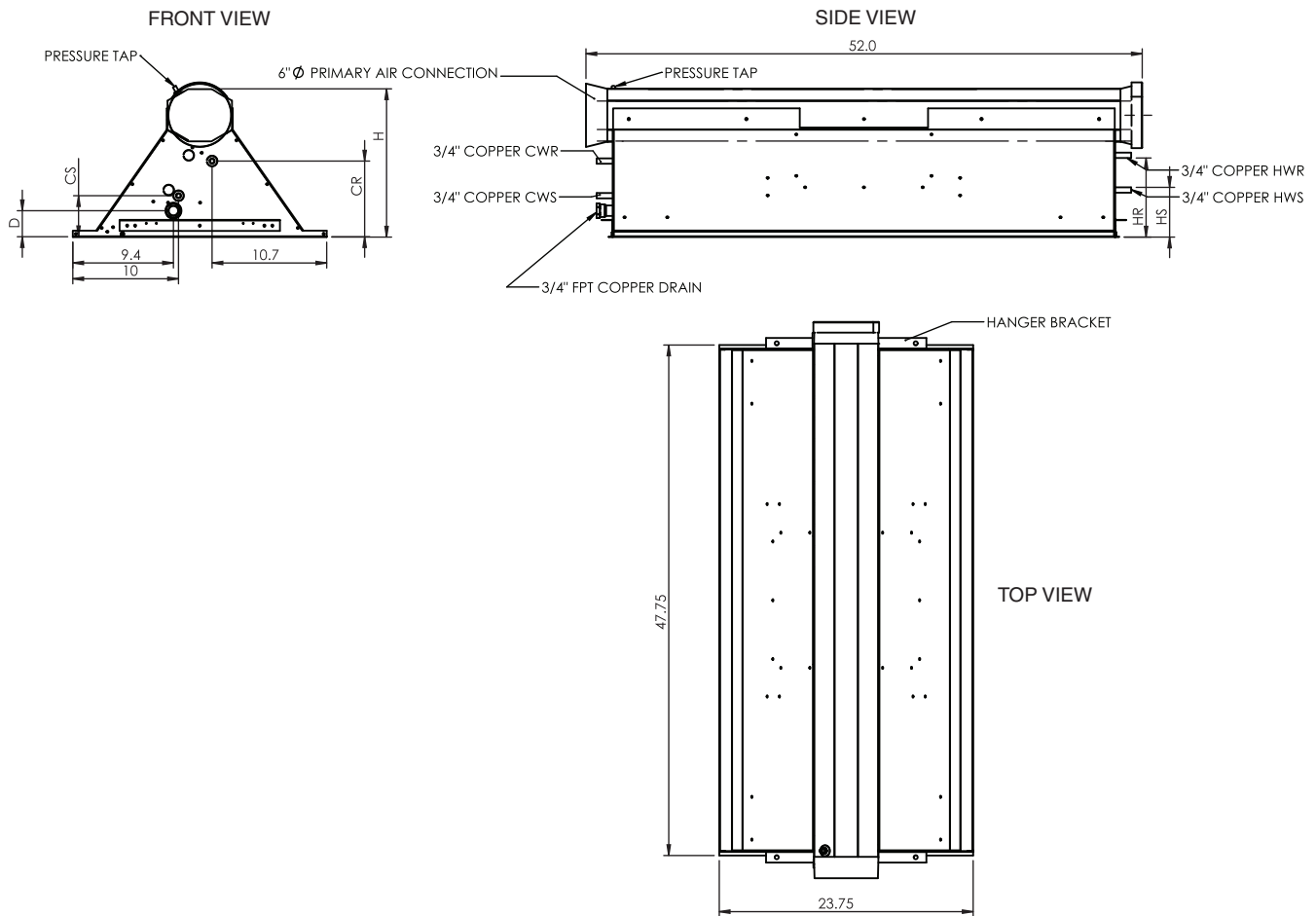

DIMENSION	H (in.)	D (in.)	CS (in.)	CR (in.)	HS (in.)	HR (in.)
Standard	14	2.6	4	7.25	4.85	7.6
Extended Version	17	5.6	7	10.25	7.85	10.6

LEGEND

- CWR** — Chilled Water Return
- CWS** — Chilled Water Supply
- HWR** — Hot Water Return
- HWS** — Hot Water Supply

NOTE: Dimensions shown in inches.

Fig. 27 — 36IBAJ 4 x 2, 1-Way Blow, 4-Pipe Unit Dimensions

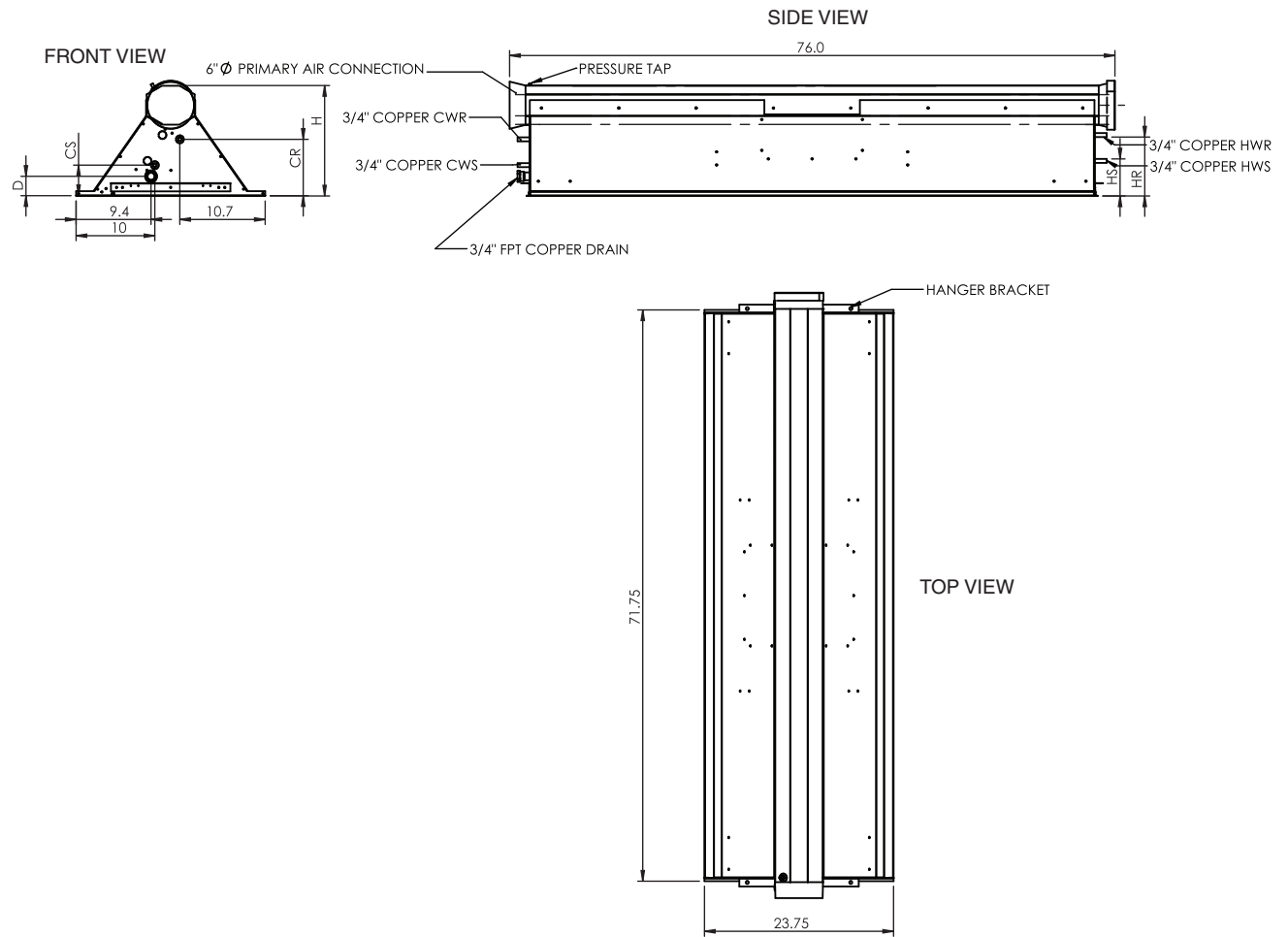

DIMENSION	H (in.)	D (in.)	CS (in.)	CR (in.)	HS (in.)	HR (in.)
Standard	14	2.6	4	7.25	4.85	7.6
Extended Version	17	5.6	7	10.25	7.85	10.6

LEGEND

- CWR** — Chilled Water Return
- CWS** — Chilled Water Supply
- HWR** — Hot Water Return
- HWS** — Hot Water Supply

NOTE: Dimensions shown in inches.

Fig. 28 — 36IBAJ 6 x 2, 1-Way Blow, 4-Pipe Unit Dimensions

Table 1 — 36IBAC Unit Physical Data

36IBAC UNIT SIZE	C	D
Weight, Dry (lb)	70	130
Weight, Operating (lb)	90	150
Length (in.)	24	48
Width (in.)	24	48
Height (in.)	12	18
Coil Connection (in.)		
2-Pipe	3/4 OD	3/4 OD
4-Pipe Cooling Coil	3/4 OD	3/4 OD
4-Pipe Heating Coil	1/2 OD	1/2 OD
Drain Connection (in.)	3/4	3/4

Table 2 — 36IBAN Unit Physical Data

36IBAN UNIT SIZE	A	B
Weight, Dry (lb)	33	41
Weight, Operating (lb)	41	49
Length (in.)	48	48
Width (in.)	12	24
Height (in.)	11 1/2	12 1/2
Coil Connection (in.)		
2-Pipe	1/2 OD	1/2 OD
4-Pipe Cooling Coil	1/2 OD	1/2 OD
4-Pipe Heating Coil	1/2 OD	1/2 OD
Drain Connection (in.)	3/4	3/4

Table 3 — 36IBAS Unit Physical Data

36IBAS UNIT SIZE	C
Weight, Dry (lb)	42
Weight, Operating (lb)	47
Length (in.)	24
Width (in.)	24
Height (in.)	16 1/2
Coil Connection (in.)	
2-Pipe	1/2 OD
4-Pipe Cooling Coil	1/2 OD
4-Pipe Heating Coil	1/2 OD
Drain Connection (in.)	3/4

Table 4 — 36IBAR Unit Physical Data

36IBAR UNIT SIZE	B
Weight, Dry (lb)	71
Weight, Operating (lb)	73
Length (in.)	48
Width (in.)	24
Height (in.)	11 1/2
Coil Connection (in.)	
2-Pipe	1/2 OD
4-Pipe Cooling Coil	1/2 OD
4-Pipe Heating Coil	1/2 OD
Drain Connection (in.)	3/4

Table 5 — 36IBAM Unit Physical Data

36IBAM UNIT SIZE	C
Weight, Dry (lb)	47
Weight, Operating (lb)	49
Length (in.)	24
Width (in.)	24
Height (in.)	15
Coil Connection (in.)	
2-Pipe	1/2 OD
4-Pipe Cooling Coil	1/2 OD
4-Pipe Heating Coil	1/2 OD
Drain Connection (in.)	3/4

Table 6 — 36IBAL,BAJ Unit Physical Data

36IBAL,BAJ UNIT SIZE	B	C	E	F* (ETO)
Weight, Dry (lb)	60	40	80	108
Weight, Operating (lb)	84	56	112	124
Length (in.)	48	24	72	96
Width (in.)	24	24	24	24
Height (in.)	14	14	14	14
Coil Connection (in.)				
2-Pipe	3/4	3/4	3/4	3/4
4-Pipe Cooling Coil	3/4	3/4	3/4	3/4
4-Pipe Heating Coil	3/4	3/4	3/4	3/4
Drain Connection (in.)	3/4	3/4	3/4	3/4

LEGEND

ETO — Engineer to Order

* Available in 2-way blow design only

INSTALLATION

It is recommended that unit locations be separated by a minimum of 8 ft from grille edge to grille edge.

Step 1 — Install Unit

36IBAC — There are two mounting brackets bolted to each side of the unit. These brackets will accept field-supplied 1/4-in. all-thread rod to facilitate the hanging of this unit. These brackets can also be used for wire hanging systems such as Sheet Metal and Air Conditioning Contractors' National Association (SMACNA) approved hanging systems. Set the unit on a cable lift or other lifting device to lift it above the ceiling level. Be careful to ensure the lifting platform is wide enough to reach the outer shell of the unit. The center drain pan and coil should not be used to support the unit.

To hang the unit, the factory recommends securing two strut channels, 24 in. apart, to the building structure where the unit is to be hung. Secure two 1/4-in. all-thread rods or wire about 20 in. apart on each channel so that they hang down to the top of where the unit is to be hung. Raise the unit and screw the all-thread rod or wire hanging from the building channels into the mounting brackets. The rod should be secured with a washer and lock nut.

Final elevation and horizontal adjustments can be made to align the unit with the diffuser. The mounting brackets have holes for the rod approximately every inch. The unit can be adjusted to meet the ceiling grid using these bracket holes, and by raising and lowering the unit to align with the ceiling by adjusting the nuts on the all-thread rod or wire on the building channel.

36IBAN — There are two holes (1/4 in. for 36IBANA, 1/2 in. for 36IBANB) on each side of the unit to facilitate hanging with an "S" hook and cable or chain to the building support. The drain pan and coil should not be used to support the unit.

These units should be hung in a manner to align with the planned ceiling grid. Final elevation and horizontal adjustments can be made to align the diffuser in the ceiling grid by raising and lowering the unit to the ceiling grid.

36IBAS,M,R,L,J — There is a hanging bracket with two $5/16$ in. holes on each side of the unit to facilitate hanging with $1/4$ -in. all-thread rod or wire. The drain pan and coil should not be used to support the unit. To hang the unit, hang four $1/4$ -in. all-thread rod or wire from the building support, aligning the unit with the planned ceiling grid. Final elevation and horizontal adjustments can be made to align the diffuser in the ceiling grid by raising and lowering the unit to the ceiling grid.

Step 2 — Connect Induction Beams to the Piping System — All piping connections can be made before the ceiling grid is in place. It is important to connect the supply water to the supply water connections and return water to the return water connections. These connections have been labeled on the unit pipe stub-outs. Be sure all air is vented at the coil before making final connections at the return.

Pipes for chilled water systems must be covered with sealed insulation to prevent condensation. Both the supply and return pipework should be insulated.

Induction beams must be capable of being shut off and having flow controlled. A valve set providing these functions should be field-supplied and installed on every zone.

In order to permit adjustment of the induction beam in vertical and lateral directions, it may be practical to connect it using flexible pipes. Flexible pipes offer greater resistance to flow than fixed pipes; therefore, it may be suitable to select flexible pipes with larger dimensions than fixed pipes.

Step 3 — Connect Induction Beams to the Condensate Drainage System — The 36IB units have one $3/4$ -in. condensate drain pan connection. When not piping to a condensate drain, the unit should be supplied with a plug or a float switch (shipped separately). The float switch should be wired in series to a room controller to shut off the coil valve if sufficient condensate should build up. If multiple units are used in a single zone, the switches should be wired in series to the room controller. If the unit is piped to a condensate removal system, the unit may be supplied with a trap and connection fitting (shipped separately). A height extension collar option may be factory provided and installed to give additional height for gravity drainage. A standard unit provides $3\ 3/4$ in. of height without any extension collar for gravity drainage of condensate. For gravity drainage, a slope of $1/4$ in. per foot of condensate pipe length is required.

Step 4 — Connect Induction Beams to the Primary Air Ducting System — A short section of insulated flexible duct can be used to connect the primary air ductwork to the unit. Make sure that the flexible duct connection to the unit is sealed air tight. A field-supplied balancing damper should be provided in this primary air duct to facilitate the air supply balancing of each unit to the scheduled static pressure at the unit inlet.

ADJUSTMENT

Airflow Balancing Procedure — To balance the air system for the induction beams, it is only necessary to adjust the inlet static pressure at each induction unit to the values shown on the schedule for each room. The inlet static pressure should be read at the duct connection to each induction beam. A static pressure tap is supplied on each induction unit for a balancer to take their readings at. The balancing contractor should attach a magnehelic gage to the factory-mounted pressure tap and adjust the volume damper to the proper inlet pressure.

If multiple induction beams in a given space are not accessible to measure the static pressure at the inlet to each unit, they can be balanced as a group, as follows.

1. Add up all the scheduled primary air to each induction beam on a given primary air duct branch feeding a common area.
2. Adjust the damper to that branch to allow the primary air quantity determined above to the space. Since induction beams all operate linearly at static pressures between 0.4 and 1.0 in. wg, all terminals on the primary air branch to a given space will operate at the common static pressure available in that branch duct that will produce the total primary air measured.
3. Total supply air is dependent on the primary air and static pressure at the unit. It can not be directly measured.

MAINTENANCE

Once per year, remove the center core of grille and vacuum off the internal heating and cooling coil with a soft vacuum brush. The removable grille can also be vacuumed off as required. If the unit was provided with a lint screen filter installed, remove the filter and vacuum off the lint.

The diffuser is used to access the coil. No tools are required. On 36IBAC units, the diffuser is spring loaded to allow access by pushing from one side. Pull back on the face core and remove the face core out of its channel frame. The unit contains a quick spring latch arrangement that slides in and out of the diffuser frame. On 36IBAM,N,R,S,L,J units, the coil can be accessed by removing the fasteners located on the face of the grille. Supply and return face sections are separate and can be removed.

Condensate Float Switch Wiring — The float switch is a normally closed dry contact electric circuit. When the float senses water, the circuit opens and the motorized water control valve is deactivated (closed). If the water control valve is a power open/spring return device, no relay is required to reset the valve. If the water control valve is a power open/power close device, a single pole double throw relay will be required to allow for automatic reset.

