

## Induction Air Terminals (Bypass and Water Control)

### GENERAL

These units are controlled by varying airflow over coil (36R) or water flow thru coil (36S). Installation instructions apply to both types of units unless exceptions are indicated.

Follow installation steps in sequence suggested. Each step includes figure(s) and procedures required for a specific stage of installation.

Set up a sample installation to familiarize all trades with their specific job function.

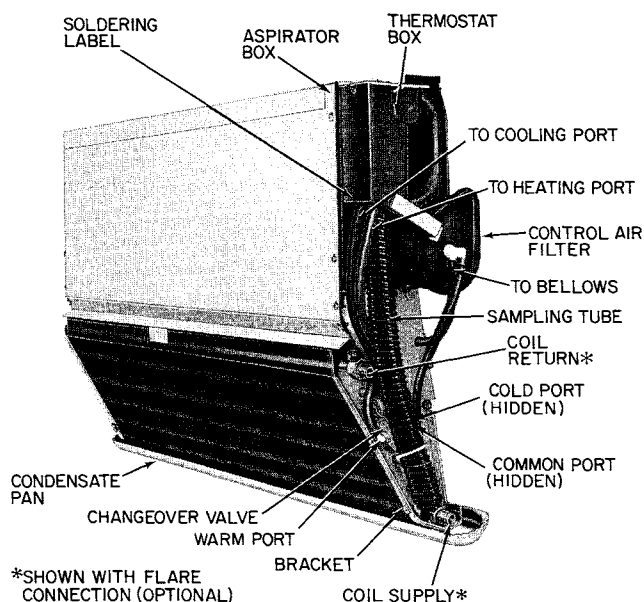

**Fig. 1 - 36RV Base Unit with Changeover**

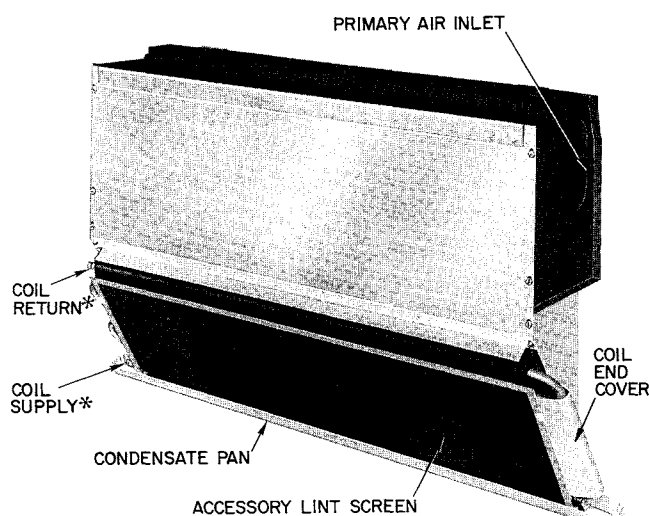

**Fig. 3 - 36SV Base Unit**

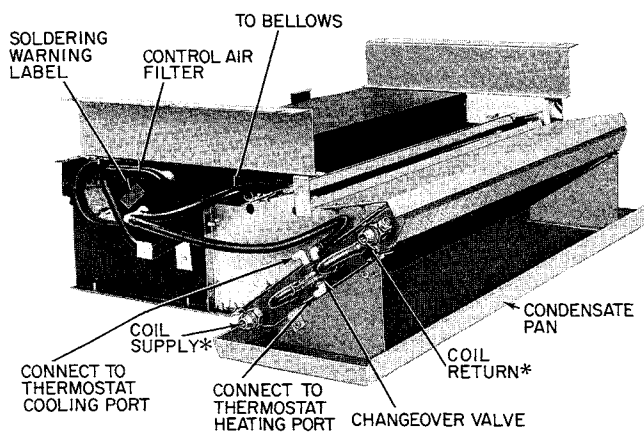

**Fig. 2 - 36RH Base Unit with Changeover  
(For Use with Wall-Mounted Thermostat)**

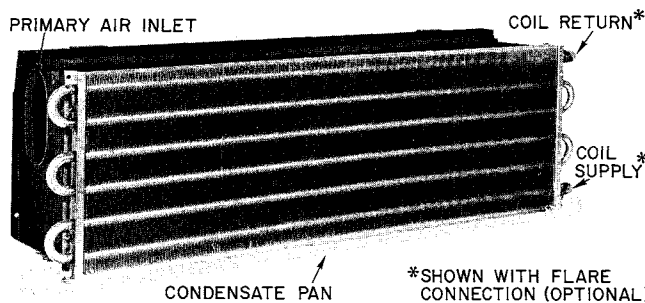

**Fig. 4 - 36SL Base Unit**

## VERTICAL UNIT INSTALLATION

### Step 1. Install wall mounting strip and hang base unit (Fig. 5).

#### 36R Units

1. Determine required length of mounting strip. Allow for length of enclosures and runouts to be used. *Maximum unsupported length of Carrier enclosures is 2 in. on either side.*
2. Locate strip per job prints. Install straight and level using field-supplied fasteners thru alternate and end holes. Shim if necessary.
3. Mark enclosure vertical center line on wall near mounting strip.
4. Remove base unit from carton. Retain carton and place over unit after installation to protect from dirt.
5. Remove unit protective packing, *including packing on rear of bypass damper.*
6. Do not remove lint screen clips (taped to condensate pan) or tee and connector (taped to side of slave unit) until required.
7. Install two No. 10-24 bolts (field-supplied) thru two No. 10-24 speed nuts provided. (These, or any other suitable means, will be used for unit leveling.)
8. Mark base unit vertical center line on unit.
9. Determine from job prints or certified prints relative position of base unit with respect to enclosure.
10. Hang base unit on wall mounting strip, using center lines for reference.
11. Level unit by adjusting two No. 10-24 bolts (or other means selected). *Accurate leveling of 36RV is essential.*

#### 36S – Follow 36R procedures, *except*:

1. Install separate mounting strip above base unit strip for hanging 36SC or ST enclosures if used.
2. Leveling bolts and speed nuts are factory supplied.

### → Step 2. Make air connections (Fig. 6).

#### 36R

1. Remove end plug from shipping position. *Do not discard.*
2. Air connections (except 36RV,RH right-hand): Apply sealer (3M Scotch Seal 800 or equivalent) to end plug and air transition fitting. Install plug and fitting to plenum connection. Connect duct to transition fitting; seal connection with duct sealer. **CAUTION:** *Excessive duct sealer may interfere with damper movement. After applying sealer, check damper for free travel by rotating adjusting screw (Fig. 16) with 1/8-in. Allen wrench.*
3. Right-hand air connection (36RV,RH only): Remove the 2 screws holding thermostat-aspirator box assembly to unit front panel; lift

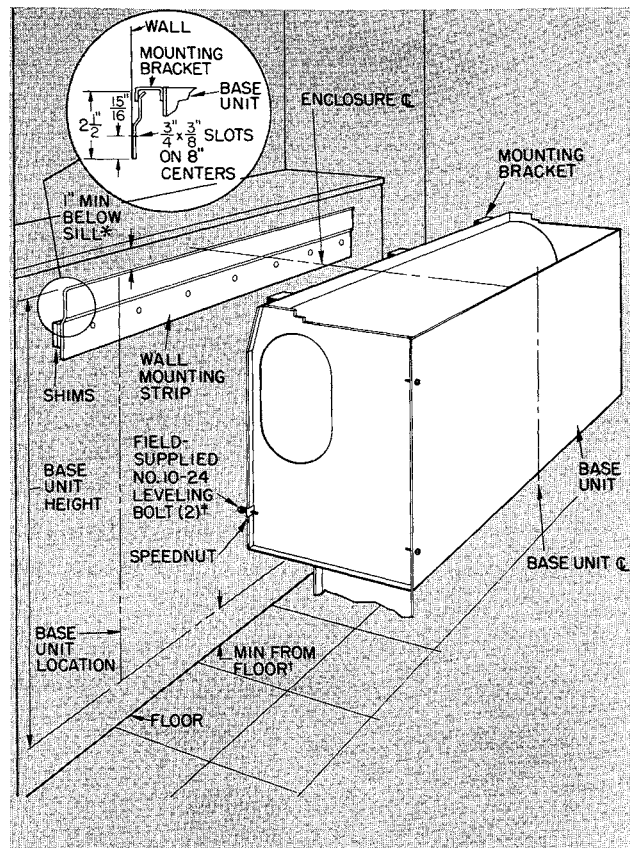

\* Required if sill has overhang; 1/8" if sill is flush with wall.  
 † From unit certified prints and/or job prints.  
 ‡ Bolt on opposite end must be adjusted to clear filter can.

Fig. 5 – Hanging Base Unit

assembly from retaining clip. Pull filter assembly carefully from unit plenum. Seal and install end plugs, fittings and ductwork (procedure 2). Reinstall filter and thermostat-aspirator box assemblies. Hook aspirator box fully over plenum side panel.

4. Check that all tubing connections are tight.

#### 36S – Follow 36R procedures 1, 2 and 4.

### Step 3. Connect piping (Fig. 7).

#### 36R

1. If coil requires reversing, see Coil Reversal.
2. Remove burrs and chips from all joints.
3. Locate piping as shown. *Do not run piping behind 36R units as this may interfere with bypass air passage.*
4. Connect water lines to coil. (Bottom coil connection is recommended for supply.)
5. Use soft or silver solder, if required, for coil connections. *Protect 36R controls and control tubing from heat during soldering.*
6. Level condensate pan; straighten strap. If drainable condensate pan is used, connect to drain line. Pitch drain line for adequate flow.
7. Insulate water and drain lines if required. Install service valves between runouts and water coil(s).
8. Compress coil end covers slightly and insert between coil end flanges, with solid (un-notched) side on forward coil flange.
9. Install lint screen against coil, securing to flange with clips provided.

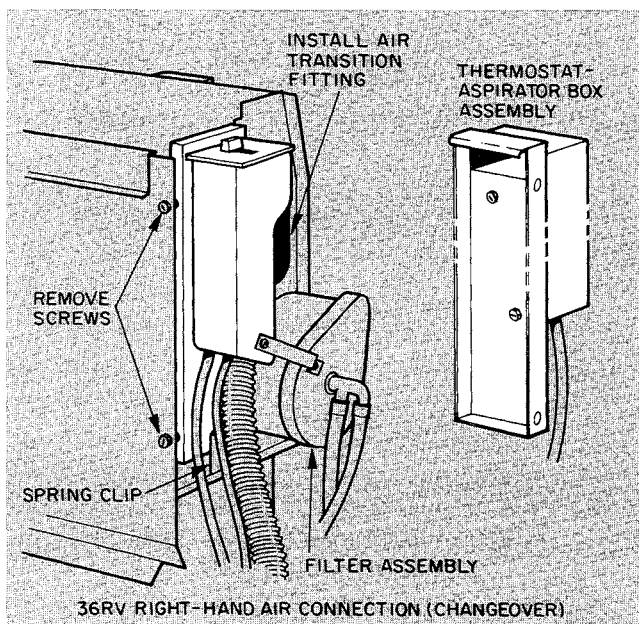
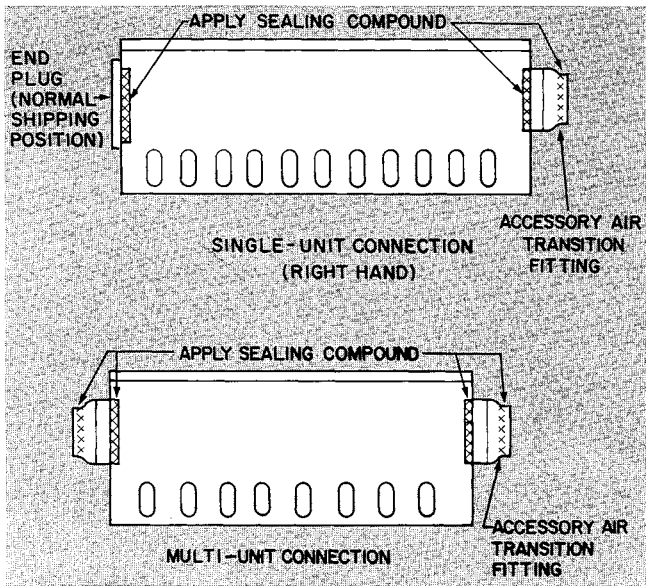

Fig. 6 – End Plug and Air Transition Fittings

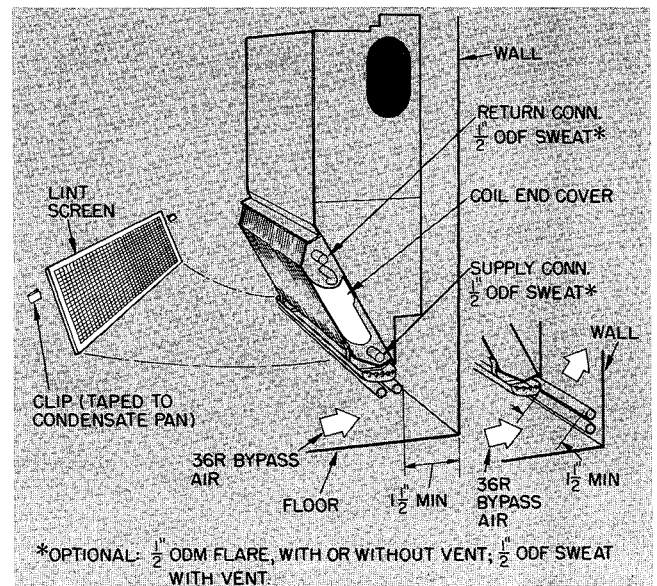

Fig. 7 – Piping Connections

36S – Follow 36R procedures, *except*:

1. Piping may run behind 36S units.
2. Install service valves between runouts and water control valves.
3. Install 2 lint screens on 36ST.
4. Install coil end covers on 36SV,SD only.

**Step 4. Interconnect 36RV master and slave units (Fig. 8).**

1. Interconnect slave and master units with control tubing, using tee and connector taped to each slave unit.
2. Up to 3 units can be controlled by 1 thermostat (1 master plus 2 slaves).
3. Eliminate all kinks in control tubing.
4. Insert sampling tube into the bracket provided (Fig. 1).

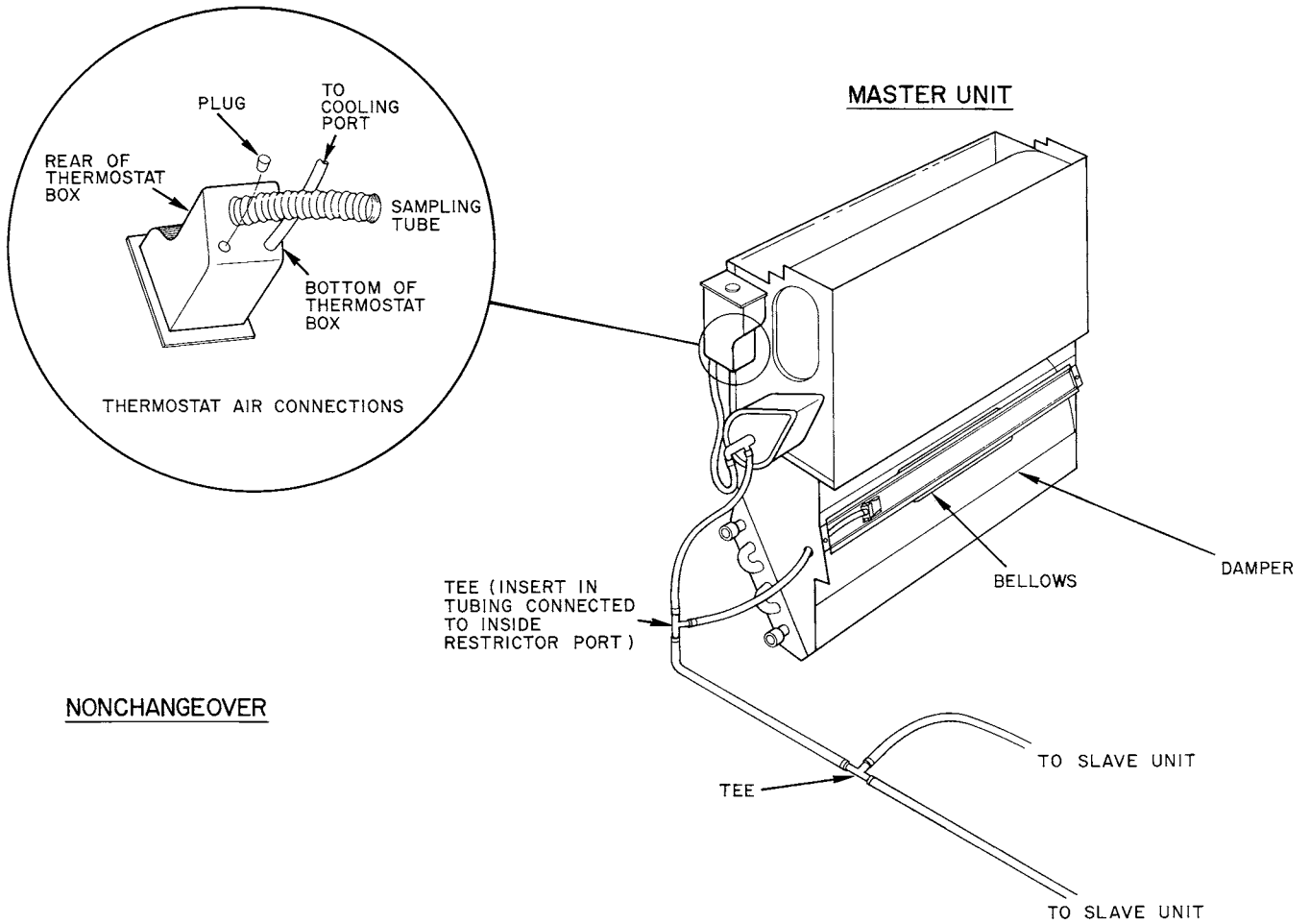
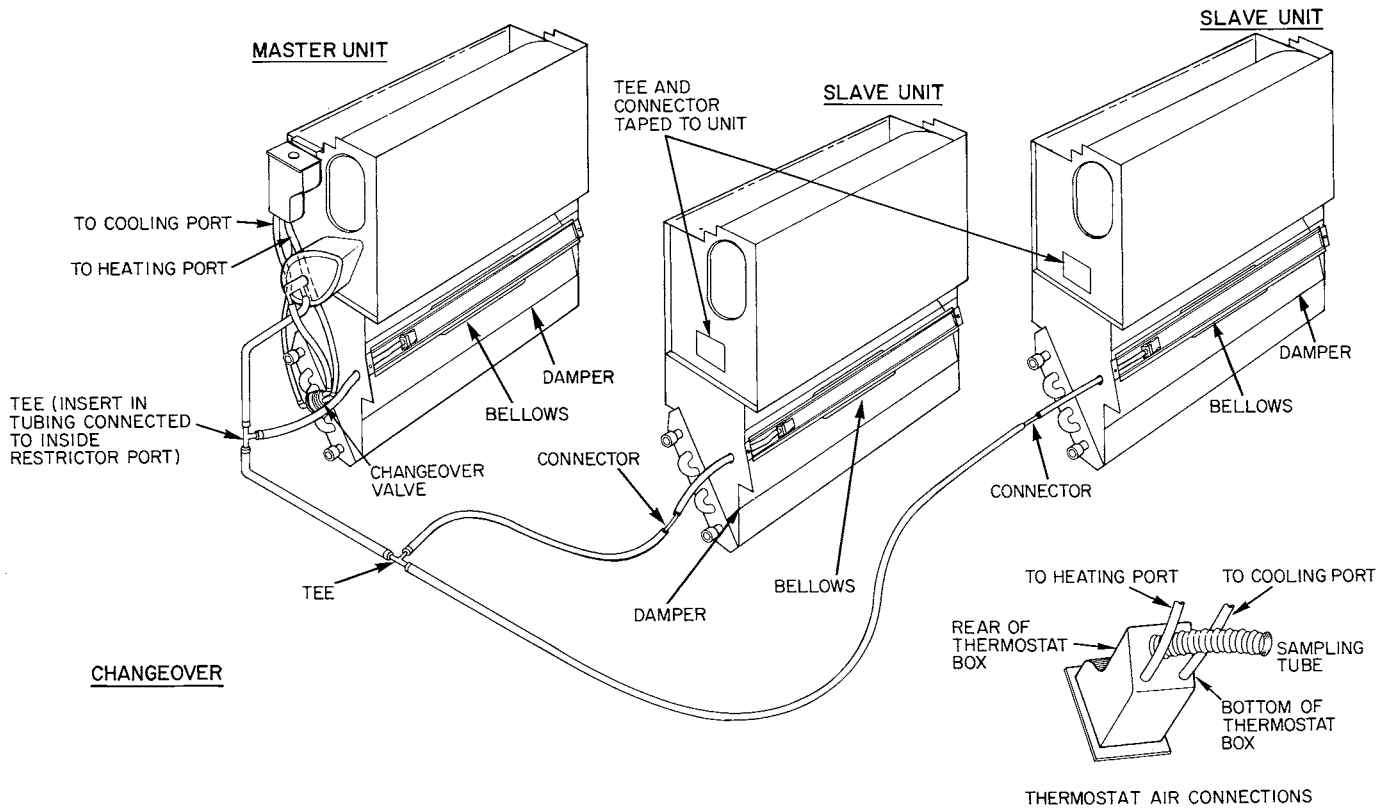

**Fig. 8 – Interconnecting 36RV Units**

**Step 5. Install accessory grilles, if supplied, on furred-in or custom enclosure installations (Fig. 9).**

**36R**

1. Position recirculation grille mounting frame, using holes provided. Install recirculation grille panel to grille frame.
2. Install discharge grille frame and removable grille sections. Field-fabricated collar may be installed on front and sides of unit discharge if required.

**36S** – Follow 36R procedures.

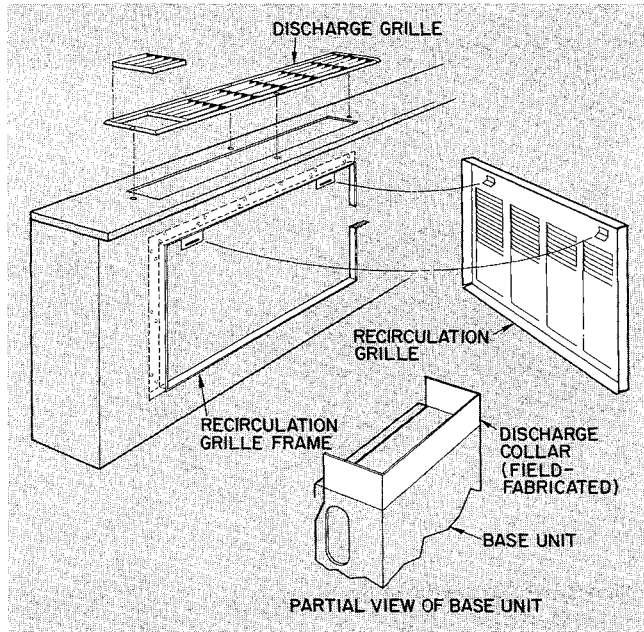

**Fig. 9 – Accessory Grilles and Field-Supplied Collar**

**Step 6. Install Carrier enclosures (Fig. 10).**

**36R**

1. Remove enclosures from carton.
2. On side-fed enclosures, remove end panel knockout as required for air connections.
3. Hang enclosure on wall mounting strip. From job prints or certified prints, determine relative position of enclosure and base unit. *Unit discharge must be in line with enclosure discharge grille.*
4. Remove front panel. Fasten enclosure to wall, using clips or tie-down holes. Reinstall panel.

**36S** – For 36SV, follow 36R procedures. For other 36S units, follow procedures 1, 3, 4 *except*:

1. 36SC,ST enclosures (with kickstrip) are for floor-fed units only; no knockout is provided.
2. Hang 36SC,ST enclosures on separate mounting strip previously installed above base unit strip.

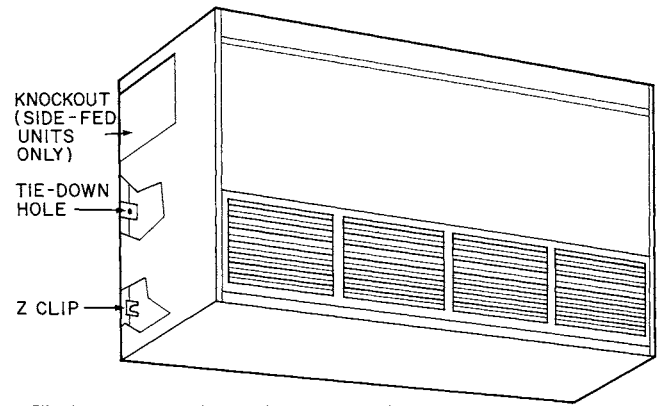

**Fig. 10 – Enclosure Installation (36RV, RM, RP, SV Side-Fed Units)**

**Step 7. Install stiffener brackets for enclosure runouts (Fig. 11).**

**36R**

1. Determine length of runout from job prints.
2. Place stiffener brackets on wall mounting strip.

**36S** – Follow 36R procedures.

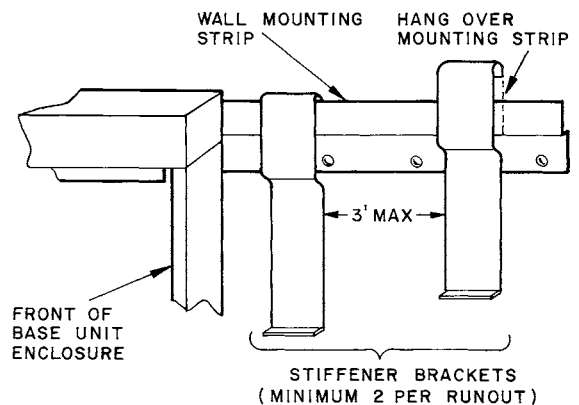

**Fig. 11 – Positioning Stiffener Brackets**

**Step 8. Install enclosure and runout arrangement as required. (Use end frame as template when drilling holes on unit enclosure side panels. Tap runout enclosure lightly to ensure tight fit in end frame slots.)**

**COLUMN-TO-COLUMN ARRANGEMENT (Fig. 12).**

**36R**

1. Drill two 3/16-in. holes for attaching runout.
2. Cut runout enclosure and enclosure panel to desired length.
3. Fit runout enclosure into slots of one end frame.
4. Insert enclosure panel into end frame slots.
5. Fit second end frame to opposite end of assembly.
6. Hang assembly on wall mounting strip and adjacent to unit enclosure. Lip of stiffener bracket must support bottom of runout.
7. Attach end frame to unit enclosure with two No. 8 sheet metal screws (field-supplied).

**36S** – For 36SV, follow 36R procedures.

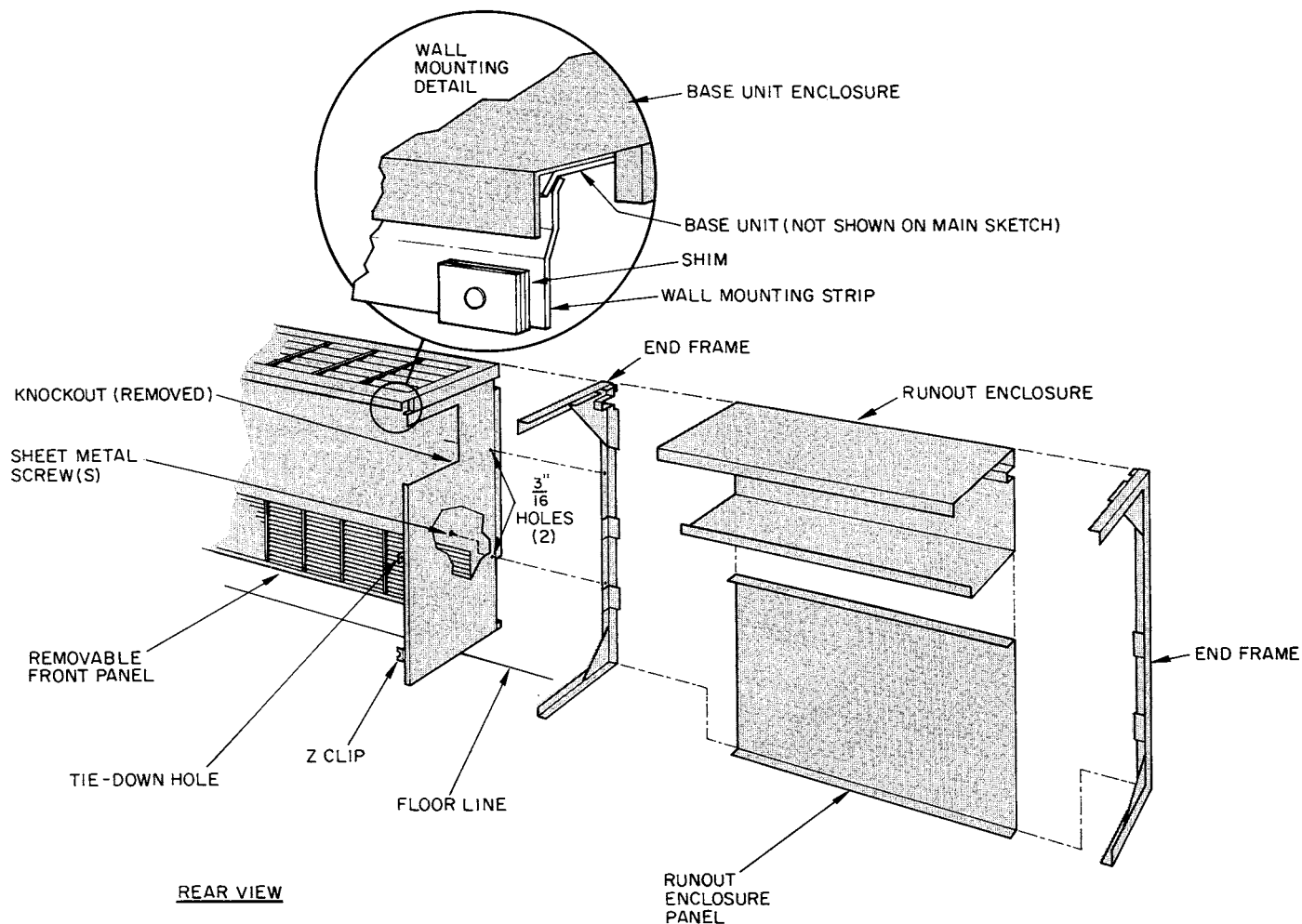

**Fig. 12 – Column-to-Column Enclosure Arrangement**

**COLUMN-TO-COLUMN WITH SHELVING  
(Fig. 13).**

**36R**

1. Drill two 3/16-in. holes for attaching runout.
2. Cut runout enclosure, back panel and shelving to desired length. *Maximum unsupported shelf length is 3 feet.*
3. Fit runout enclosure into slots of 2 end frames.
4. Install end panels flush with front of runout enclosure, leaving space at bottom to insert shelving. Fasten end panels to runout enclosure with U-clips.
5. Insert shelving below end panels, with flanges turned down. Shelving rests on lower flange of end frame.
6. Follow procedures 6 and 7 of Column-To-Column Arrangement.

**36S** - for 36SV units, follow 36R procedures.

**ENCLOSURE WITH SINGLE OR DUAL  
RUNOUT (Fig. 14).**

**36R**

1. Drill one 3/16-in. hole for attaching runout.
2. Cut runout enclosure to desired length; fit into slots of 2 end frames.
3. Hang assembly on wall mounting strip and adjacent to base unit enclosure. Lip of stiffener bracket must support bottom of runout.
4. Attach end frame to base unit enclosure with one No. 8 sheet metal screw (field-supplied).

**36S** – For 36SV units, follow 36R procedures.

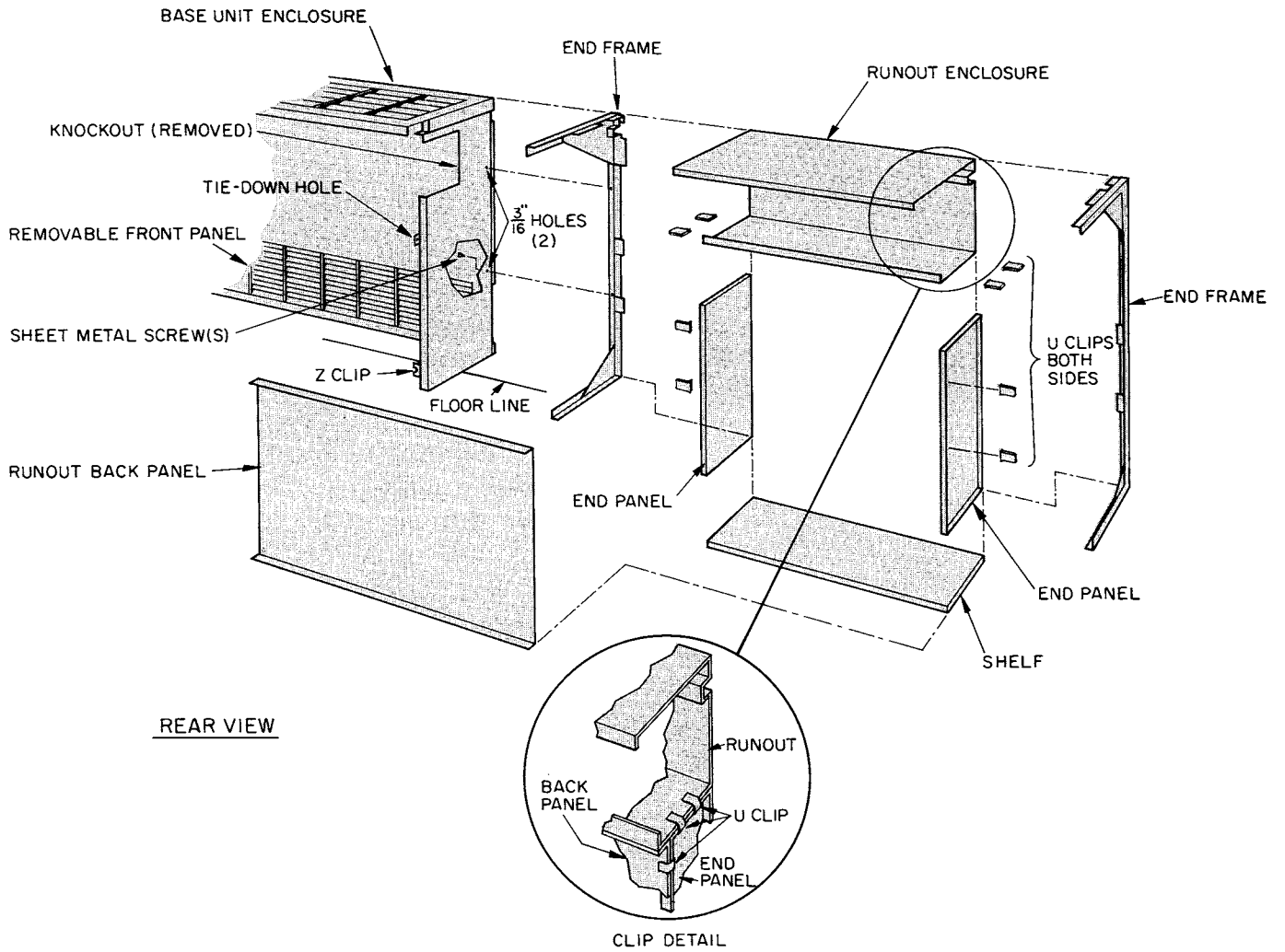

**Fig. 13 – Column-to-Column Enclosure With Shelving**

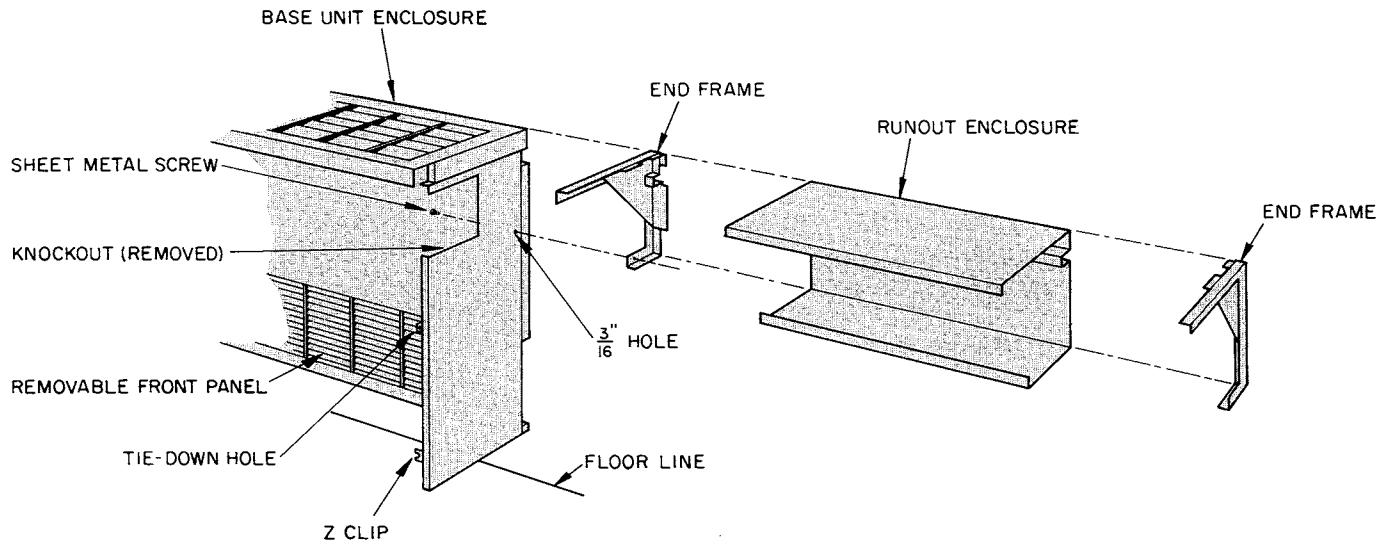

**Fig. 14 – Enclosure with Single or Dual Runout**

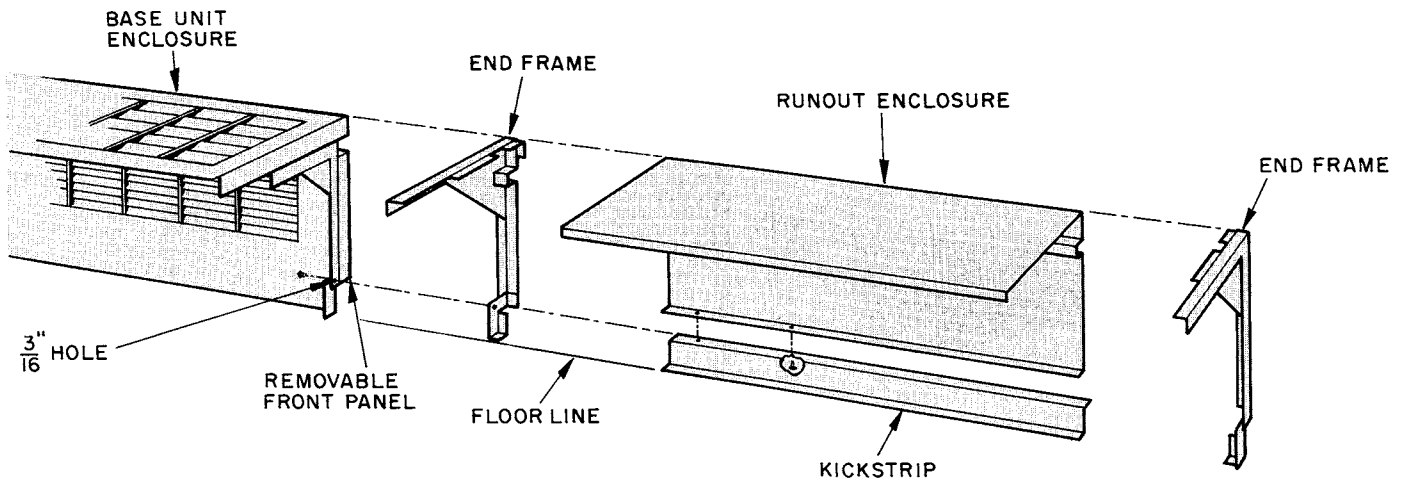

Fig. 15 – Single or Dual Runout (With Kickstrip)

**SINGLE OR DUAL RUNOUT WITH KICKSTRIP**  
(Fig. 15).

**36SL**

1. Drill one 3/16-in. hole for attaching runout.
2. Cut runout enclosure and kickstrip to desired length; join with No. 8 sheet metal screws.
3. Fit runout and kickstrip into slots of 2 end frames.
4. Hang assembly on wall mounting strip and adjacent to unit enclosure.
5. Attach end frame to unit enclosure with one No. 8 sheet metal screw (field-supplied).

**Step 9. Balance system (Fig. 16).**

**36R**

1. Remove construction debris from unit. Remove protective plastic from thermostat cover.
2. Units are shipped with plenum damper wide open. Turn damper adjustment screw clockwise to close damper and decrease nozzle pressure to design value. Two or 3 runs may be necessary to obtain proper balance. *36RV (RH) units require minimum of 1.5 in. wg plenum pressure for control operation. Maximum allowable plenum pressure is 5 in. wg.*
3. Total primary airflow to a series of units fed by common runout should not exceed 220 cfm.

**36S** – Follow 36R procedures. Note different type nozzle on 36SL,SM,SC,ST.

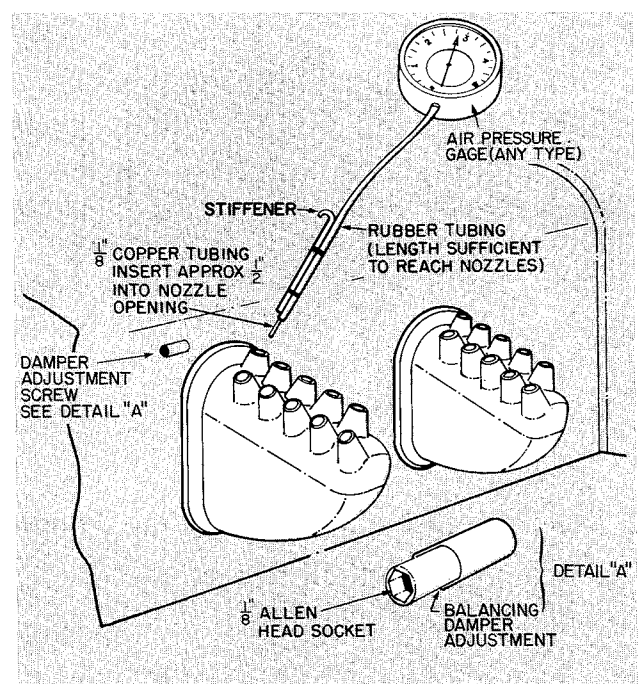
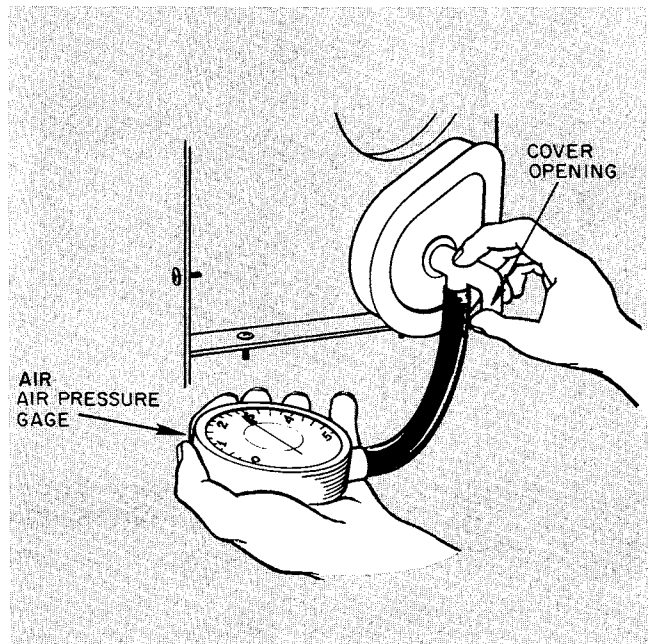

Fig. 16 – Pressure Measurements



## HORIZONTAL UNIT INSTALLATION (Unit- or Wall-Mounted Thermostat)

### Base Unit Not in Carrier Enclosure (Fig. 17, 18)

#### 36RH

1. Remove unit from carton. Remove protective packing, *including that on rear of bypass damper.*
2. Remove Z bars from shipping position. Fasten to unit with screws and clips provided.
3. Insert short lint screen (9½-in. height), if used, adjacent to water coil. Use 2 screws and clips taped to unit front panel. Install 1 screw on either side of coil support and below screen. Install clip thru hole as shown.
4. Locate unit per job prints. Suspend as shown.
5. Level unit, using drain pan as reference. *Accurate leveling of 36RH is essential.*
6. Make air connections (Vertical Unit Installation, Step 2).
7. Make piping connections (Vertical Unit Installation, Step 3, 1 thru 7 only).
8. Interconnect master and slave units where unit-mounted thermostats are provided (Fig. 18).
9. Install wall mounted thermostat, if used, and interconnect master and slave units (see instructions included with thermostat).
10. Balance system (Vertical Unit Installation, Step 9).

**36SH** – Follow 36RH procedures 1-7 and 10 (no controls supplied with 36SH units).

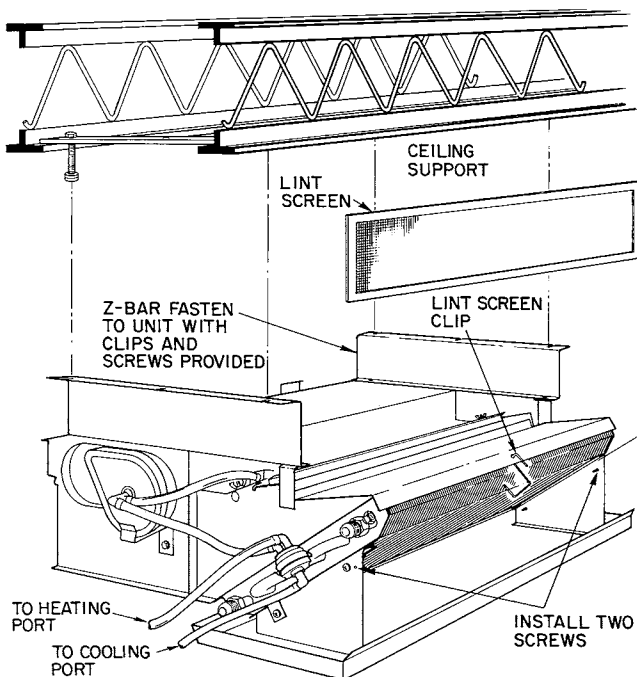

→ **Fig. 17 – 36RH Base Unit Installation**

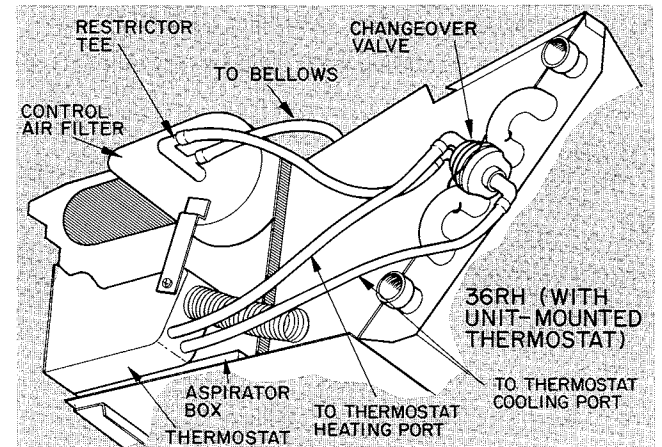
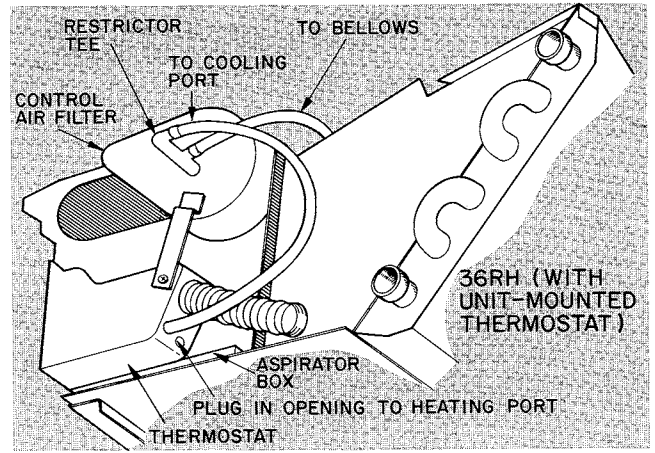

→ **Fig. 18 – 36RH Control Air Connections  
(Unit-mounted thermostat)**

### Base Unit in Carrier Enclosure (Fig. 19)

#### 36RH

1. Remove base unit, enclosure and ceiling mounting plates from their cartons. Remove protective packing, *including that on rear of bypass damper.*
2. Remove four No. 10-16 x ½-in. screws taped to inside of enclosure end panel.
3. Remove Z bars from shipping position; fasten to unit with screws and clips provided. Install ceiling mounting plates to ceiling; lift unit and fasten Z bars to mounting plates. (Mounting plates may be installed on Z bars and entire assembly lifted to be secured to ceiling.)
4. Follow procedures 3 thru 9, Horizontal Units Not in Carrier Enclosures.
5. Install long lint screen (11½-in. height).
6. Lift enclosure so that its flanges pass thru slots in ceiling mounting plate. Slide enclosure flanges over mounting plate flanges; fasten with 4 screws provided.
7. Balance the system (Vertical Unit Installation, Step 9).

**36SH** – Follow 36RH procedures, *except:*

1. No controls supplied for 36SH units.
2. Instructions for interconnection of slave units do not apply.

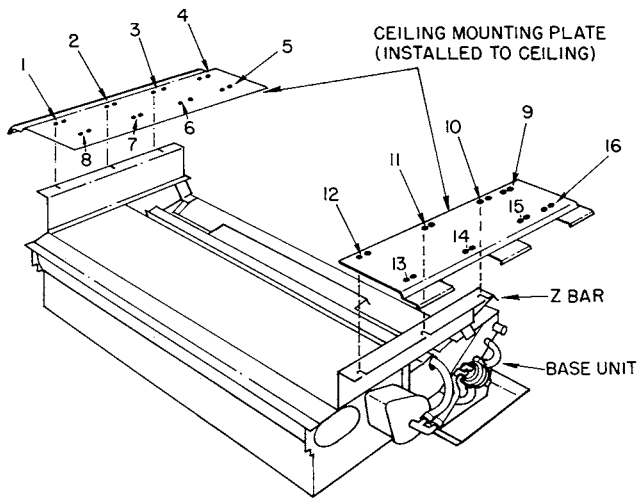

Right-hand air connection — Use holes 1-4, 9-13, 16.  
 Left-hand air connection — Use holes 1, 4-8, 13-16.

ASSEMBLY OF ENCLOSURE TO MOUNTING FRAME

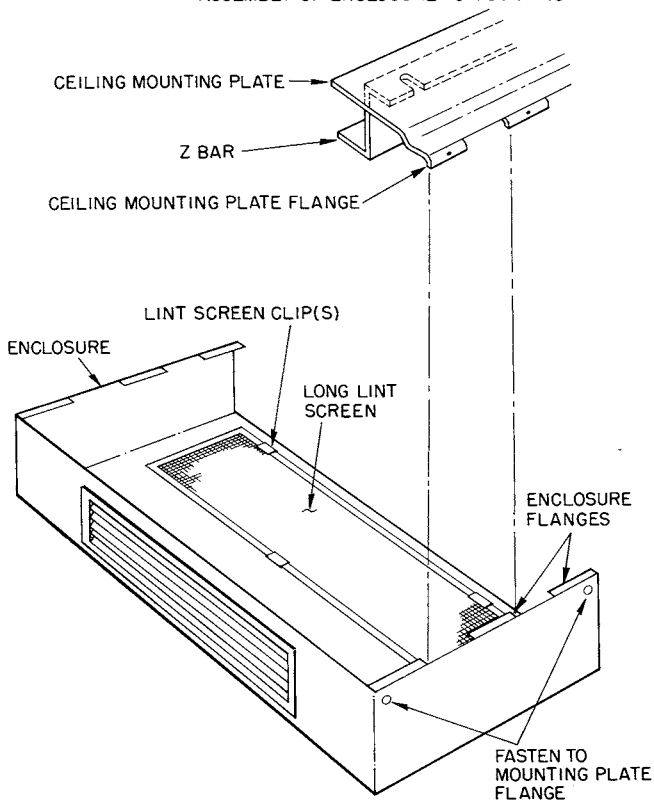

Fig. 19 — 36RH Installed in Carrier Enclosure

**Coil Reversal (Fig. 20)** — Do not reverse coils having vent fittings (except 36SL,SM,SC,ST). To reverse coils without vent fittings:

**36R**

1. Remove sheet metal screws fastening condensate pan to coil.
2. On 36RV,RH units, remove changeover valve (if used). *Do not remove control tubing.*
3. Remove sheet metal screws holding coil to unit.
4. Reverse coil end-over-end.
5. Reassemble coil to unit; reinstall changeover valve; reinstall condensate pan. Be sure tubing is not kinked; shorten if required.

**36S** — For 36SV,SH,SD, follow 36R procedures. Reverse coil in horizontal plane on 36SL,SM,SC,ST units.

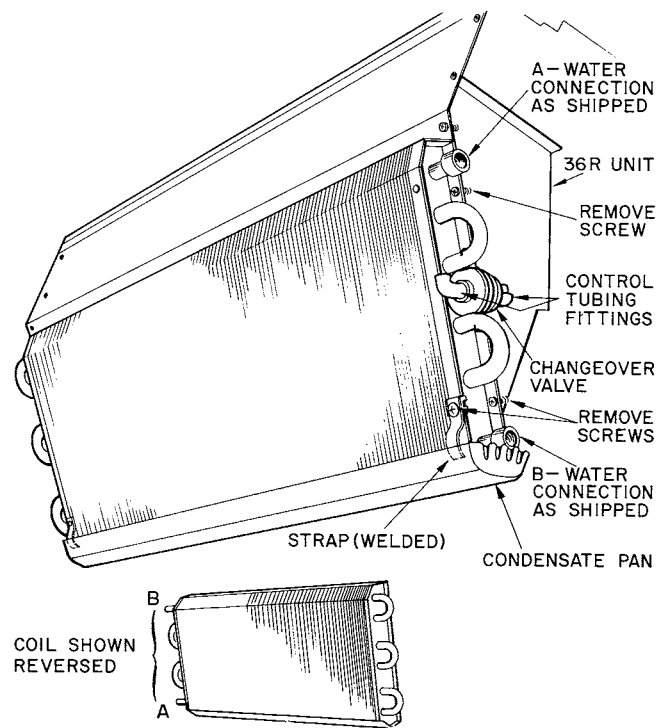

Fig. 20 — Coil Reversal (36RV)



Manufacturer reserves the right to discontinue, or change at any time, specifications or designs without notice and without incurring obligations.

Book	3
Tab	6a

Form 36R,S-1SI  
Supersedes 36RV501105 and 36RV511105

Printed in U.S.A.

7-68

PC 201

Catalog No. 533-617