



www.geo-flo.com

Engineered Solutions
Making Geothermal Easier

Installation, Operating, and Maintenance Manual



Part # 3704
Rev. 28OCT2015

Geo-Flo Universal Pump Controller (UPC-GEO) by Grundfos

Geo-Flo Products Corporation
905 Williams Park Drive
Bedford, Indiana 47421, U.S.A.

Main Number: 812-275-8513
Toll Free: 800-784-8069
Fax: 888-477-8829

Table of Contents

General Description	1	Setup (con'd).	
Overview	1	Flow Configuration12
Flow Rate Based Control	1	ΔT Configuration13
ΔT Based Control	2	Sensor Configuration13
Technical Specifications	2	Media Configuration14
Agency Listing/Approvals	3	Mode Setup14
Dimensional Data	3	Lockout Setup14
Installation	4	Controller Output Signal Setup15
Location	4	Troubleshooting16
Tools Required	4	Appendix A: Sensor Kit Descriptions17
Legend of Abbreviations	4	Appendix B: Installing Sensors20
Mounting	4	Appendix C: Thermistor Temp/Resist Chart21
Wiring (Single Unit -- Magna GEO Pump)	5	Appendix D: Important Power Considerations.22
Wiring (One Flow Center/Two Heat Pumps)	8	Appendix E: Controller Mounting Template23
Wiring (0-10 VDC output)10	Appendix F1:	
Setup11	Pressurized Var. Spd. Flow Center Submittals24
Quick Start Procedure11	Appendix F2:	
General Navigation11	Non-press. Var. Spd. Flow Center Submittals25
Main Page11	Appendix G: Antifreeze Fluid Factors.31
System Status.12	Revision Table32
Setup Menu12		

NOTES:

This guide provides the installer with instructions specific to Grundfos Universal Pump Controller (UPC-GEO). Please refer to your heat pump manufacturer’s instructions or IGSHPA guidelines for additional detailed flushing, purging, and installation information. Please review the entire IOM document before proceeding with the installation.

Geo-Flo Products Corporation is continually working to improve its products. As a result, the design and specifications of products in this document may change without notice and may not be as described herein. For the most up-to-date information, please visit our website, or contact our customer service department. Statements and other information contained in this document are not express warranties and do not form the basis of any bargain between the parties, but are merely Geo-Flo’s opinion or commendation of its products.

General Description

Overview

The Geo-Flo Universal Pump Controller (UPC-GEO), designed in collaboration with Grundfos, is a 24VAC powered controller that operates a one- or two-pump variable speed flow center system to provide accurate pump control and feedback resulting in the lowest possible power consumption for the pump(s) and system (PWM output only; feedback not available for 0-10 VDC output). Instantaneous pump power in Watts is displayed on the back-lit LCD (PWM output only) along with other system parameters depending on which sensors are installed. The installation technician decides whether to control the pump speed based on flow rate set points or differential temperature (ΔT) set points. Installing a single Grundfos Vortex Flow Sensor (VFS) with the UPC-GEO allows the system to be controlled using a flow rate set point input into the controller based on the requirements of the heat pump. The controller allows separate flow rate inputs for two-speed heat pumps, which results in substantial energy savings due to lower flow rate requirements in first-stage heat pump operation. The Grundfos Vortex Flow Sensor provides both flow rate and temperature feedback which is displayed on the controller. Differential temperature (ΔT) control requires the addition of two immersion thermistors and allows separate ΔT inputs for heating and cooling modes. Installing both a VFS sensor and thermistors allows the UPC-GEO to display flow rate, ΔT , and heat of extraction/rejection in KBTU/H. Two lockout modes allow the installer to choose whether to lock the system parameters so they cannot be inadvertently changed or to lock the screen so the feedback (temperatures, flow rate, power, etc.) are not displayed. A Meter mode is included which allows the UPC-GEO to display temperature, flow, and MBtu parameters but does not control the pump(s).

Flow-rate based control (Grundfos VFS flow sensor required)

The UPC-GEO receives a 24VAC signal from the heat pump or thermostat for stage-one or stage-two heating or cooling. The UPC-GEO then provides a PWM signal to the variable speed Magna GEO 32-140 pump (or 0-10 VDC output for other pumps) and monitors the output signal from the Grundfos VFS flow sensor and pump. The UPC-GEO increases or decreases the pump speed based on the flow rate input into the controller and the actual flow rate of the system. For higher flow rate and/or head loss systems a two-pump variable speed flow center may be required. This flow center consists of a single variable speed Magna GEO 32-140 and a constant speed UPS26-99. The UPC-GEO attempts to satisfy the flow rate requirement by first using the more efficient Magna GEO 32-140 pump. If the Magna GEO reaches its maximum performance level before satisfying the flow rate set point requirement, the UPC-GEO energizes the UPS26-99 and ramps the Magna GEO down to match the requirement, thereby minimizing pumping power. The UPC-GEO saves the pump signal settings to allow it to quickly deliver the required flow rate on subsequent calls for heating or cooling. On two-pump variable speed flow center systems the UPC-GEO energizes the UP26-99 for 30 seconds every 72 hours if it has not run during that same period.

ΔT based control (Two immersion thermistors required)

The UPC-GEO receives a 24VAC signal from the heat pump or thermostat for heating or cooling. The UPC-GEO then provides a PWM signal to the Magna GEO 32-140 pump (or 0-10 VDC output for other pumps) and monitors the temperatures provided from the EWT and LWT thermistors and the return signal from the pump. The UPC-GEO drives the pump at 90% for two minutes before increasing or decreasing the pump speed based on the delta-T (ΔT) set point for heating or cooling mode and the actual ΔT of the system. The controller recognizes whether the heat pump is in heating or cooling mode by monitoring the EWT and LWT temperatures (i.e. heating mode: $LWT < EWT$; cooling mode: $LWT > EWT$). For higher flow rate and/or head loss systems a two-pump variable speed flow center system may be required. This flow center consists of a single variable speed Magna GEO 32-140 and a constant speed UPS26-99. The UPC-GEO attempts to satisfy the ΔT requirement by first using the more efficient Magna GEO 32-140 pump. If the Magna GEO reaches its maximum performance level before satisfying the ΔT set point requirement, the UPC-GEO energizes the UPS26-99 and ramps the Magna GEO down to match the requirement thereby minimizing pumping power.

Technical Specifications

Parameter	Rating	Tolerance (+/-)
Input Voltage	24 VAC, 200 mA Max	10%
Input Frequency	60 Hz	20%
PWM Input Frequency	75 Hz	10%
PWM Input Voltage	Open Collector	n/a
PWM Output Frequency	3.9 kHz	10%
PWM Output Voltage*	12 VDC	10%
0-10 VDC Output Voltage*	1 to 10 VDC	10%
Thermistor Input	NTC 10k	N/A
HP IN1	24 VAC or dry contact across terminals	10% (for 24 VAC Input)
HP IN2	24 VAC or dry contact across terminals	10% (for 24 VAC Input)
1-10 VDC input	Not currently used	N/A
GND	Earth Ground Connection	N/A
L1/N1 (input for second pump)	120/208-230 VAC	10%
L2/N2 (output for second pump)	120/208-230 VAC	10%
Relay for L1/N1 to L2/N2	4A Max	N/A
Display	128 x 64 pixels	N/A
DB9 connector (serial communication)	N/A	
Nominal power consumption	3.5 VA	N/A

*Default controller output is PWM. Alternate 0-10 VDC output may be selected in the controller menu for Flow mode or ΔT mode.

Agency Listings/Approvals



Certified to CSA C22.2 No 24
 Conforms to UL Standard 873

Dimensional Data

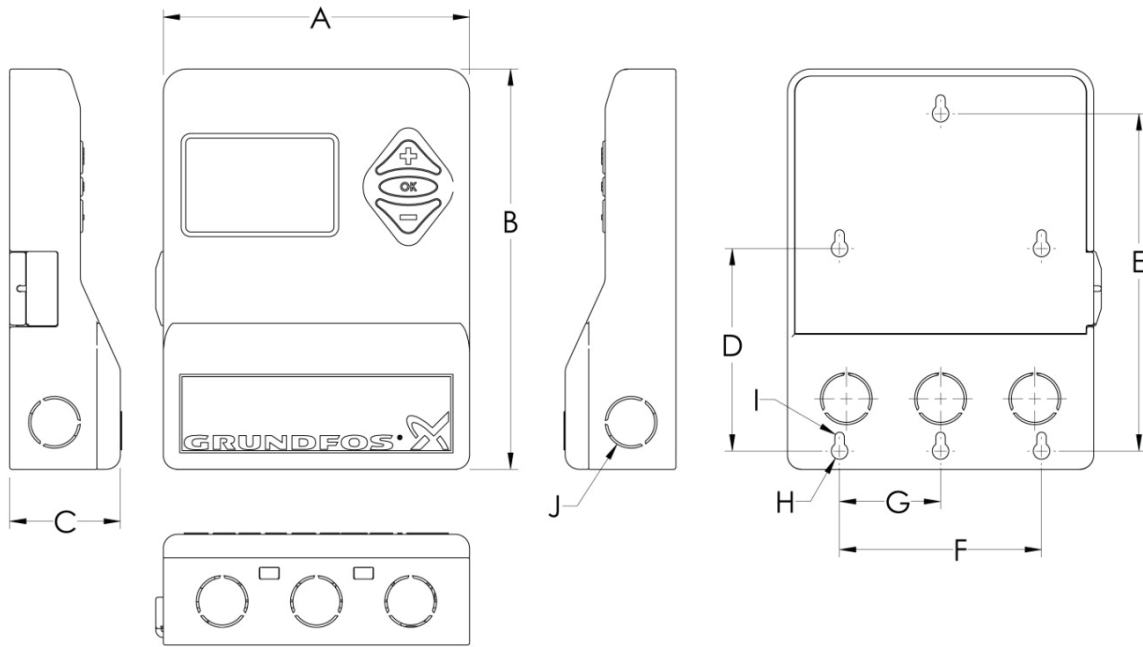

	A	B	C	D	E	F	G	H	I	J	Weight	
Inches	5-1/8	6-11/16	1-7/8	3-3/8	5-5/8	3-3/8	1-11/16	Φ1/4	Φ3/16	1/2" standard conduit knockout	LBS	KG
CM	13	17	4.7	8.6	14.3	8.6	4.3	Φ0.7	Φ0.4		0.75	0.34

Installation

Location

The UPC-GEO can be mounted in any available indoor climate controlled location in or around the mechanical room near the variable speed pump or flow center. All UPC-GEO kits include mounting hardware and a ten foot cable that allows the controller to be connected to the Grundfos Magna pump. This equipment should be installed and serviced by qualified personnel only.

Please review the entire Installation Instructions document before proceeding with installation.

Tools Required

No 2 Philips Screwdriver
3/16" Flathead Screwdriver
Drill
3/16" Drill bit
Hammer
Small Philips or flathead screwdriver
Wire cutters/strippers
Electrical Tape

Legend of Abbreviations

EWT	Entering Water Temperature (from loop to heat pump)
LWT	Leaving Water Temperature (to loop from heat pump)
PWM	Pulse Width Modulation
BRN	Brown
BLK	Black
BLU	Blue
HP IN#	Heat Pump Input # (used for Stage # call)
THERMS	Thermistors
C	Common
GND	Earth Ground
L	Line
N	Neutral
KBTU/H	1000 BTU per hour

Mounting the Controller

1. Using the template included in Appendix C, mark the mounting hole locations and install the plastic wall anchors (if necessary).
2. Remove the controller's wiring cover by releasing its tabs with a 3/16" flathead screwdriver as shown in Figure 1.
3. Install the upper #6 screw and slide the controller into place. Install the second screw to secure the controller to the wall.

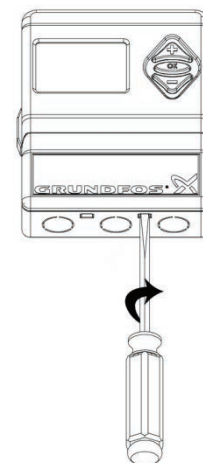

Figure 1: Mounting Controller

Wiring the Controller (Single Heat Pump -- Magna Geo Pump)



WARNING: OPEN THE POWER SUPPLY DISCONNECT SWITCH AND SECURE IT IN AN OPEN POSITION PRIOR TO PERFORMING ELECTRICAL WORK. VERIFY THAT POWER HAS BEEN DISCONNECTED PRIOR TO WIRING THE CONTROLLER. FAILING TO SECURE THE ELECTRICAL SUPPLY COULD RESULT IN SERIOUS INJURY OR DEATH. THIS EQUIPMENT SHOULD BE INSTALLED AND SERVICED BY QUALIFIED PERSONNEL ONLY.

NOTE: The Magna GEO 32-140 motor requires no external protection. Wiring the Magna GEO directly to mains power is recommended. See Appendix C for more information.

NOTE: Low voltage wiring will vary depending on the installation and sensors used.

1. Turn off power at the heating/cooling system or fuse/circuit breaker panel.
2. Decide on where wires will enter the controller housing and remove the appropriate knock-outs.
3. Figures 2a through 2d provide controller terminal descriptions and wiring for a single unit; Figure 3 shows wiring for two heat pumps. Complete wiring using appropriately sized wire and replace controller’s cover.

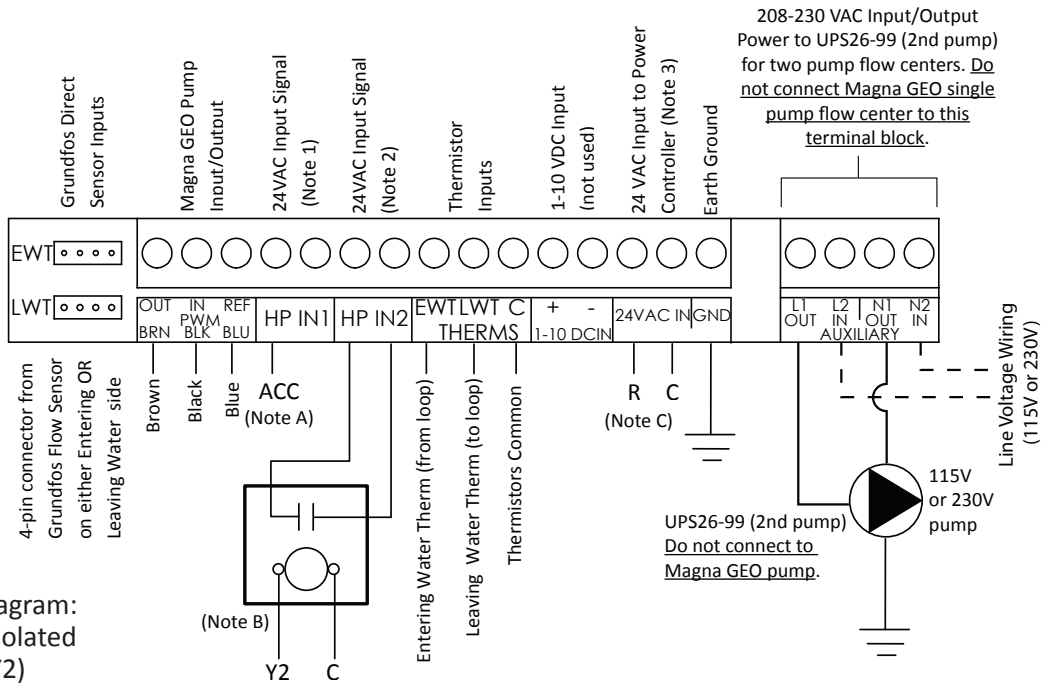

Figure 2a: Wiring Diagram: Single heat pump (isolated accessory relay for Y2)

NOTES:

- A. HP IN1: Left terminal receives 24VAC input from heat pump accessory output (labeled “ACC” or “A” by some heat pump manufacturers). **IMPORTANT:** Some heat pump accessory relay contacts are not isolated from the 24 VAC heat pump transformer, and may create a “dirty” power signal, especially heat pumps with thermostat-controlled ECM fan motors (symptom includes variable speed pump not shutting off). An additional relay will be required for these heat pumps (see Figure 2b). If an accessory terminal is not available, Figures 2c and 2d illustrate connections. Alternatively, ΔT mode may be used, which will only require one relay (coil connected to Accessory and C; contacts connected to HP and IN1).

- B. HP IN2: Receives a contact closure from the relay connected to Y2, closing the circuit between the left and right terminals. This connection is not required when operating the controller in ΔT mode. Relay is a SPST N.O. general purpose relay (equivalent to 90-360 WR/RBM Type 184).
- C. 24VAC IN: Left terminal connected to “R” at heat pump; right terminal connected to “C” at heat pump.

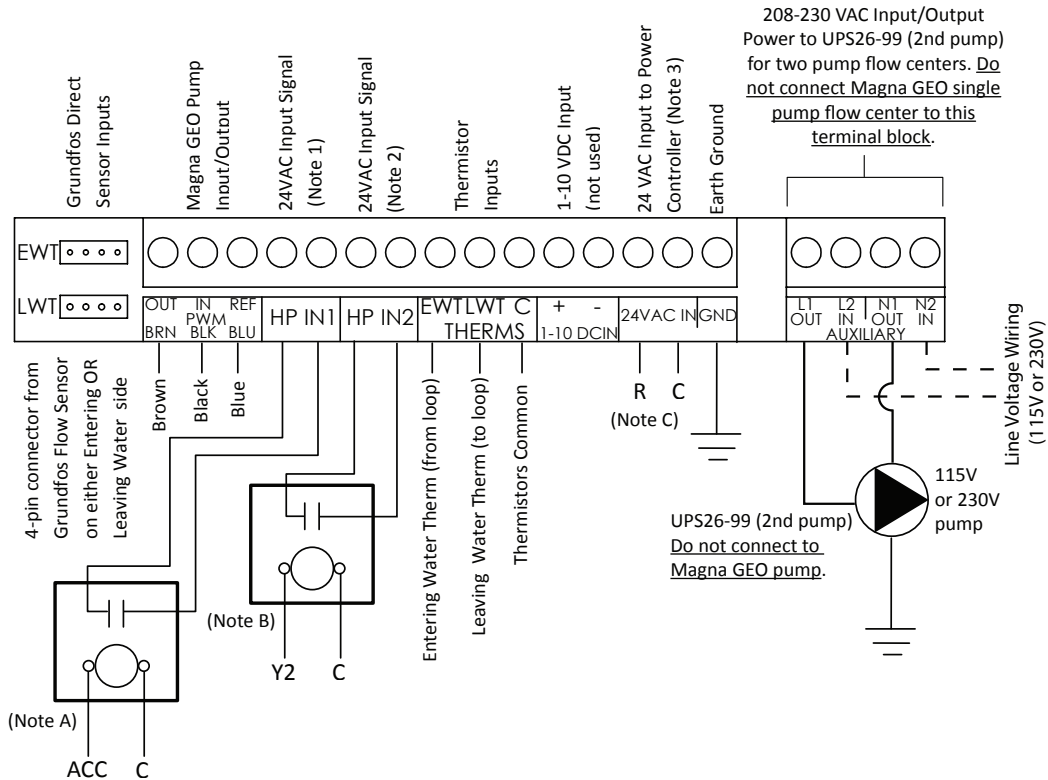
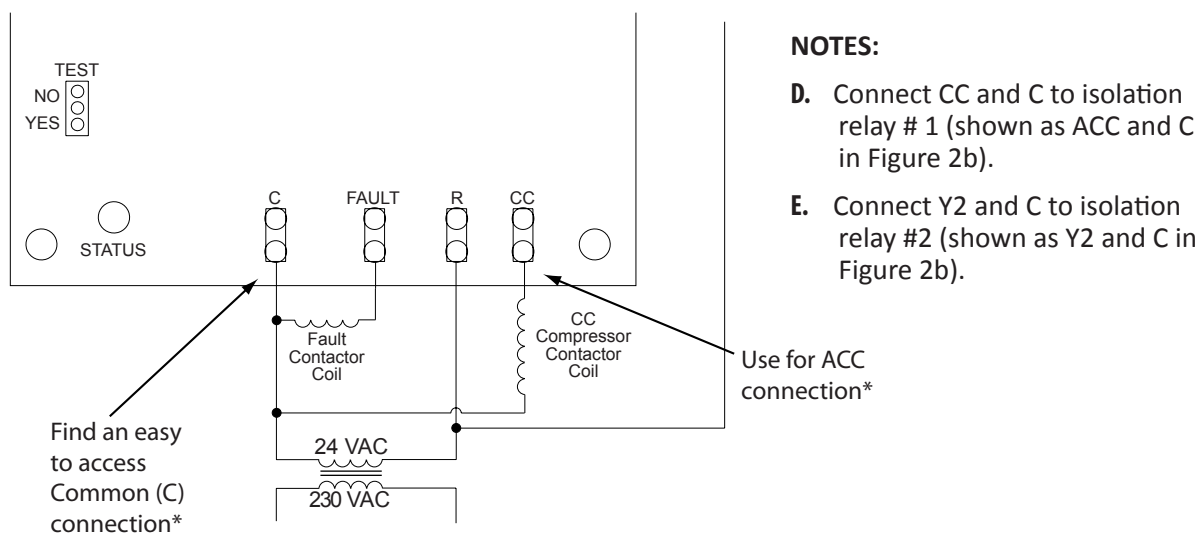
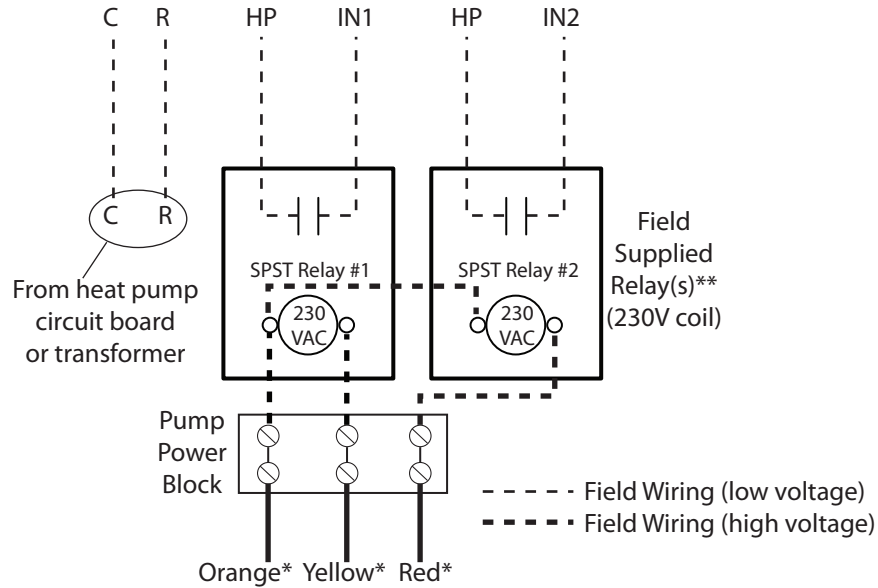

Figure 2b: Wiring Diagram for heat pumps requiring an additional isolation relay -- see Notes A & B, above



*May require a “piggyback” spade connector.

Figure 2c: Wiring Diagram for heat pumps with an external compressor contactor, but without an accessory relay -- see Note A, previous page



*Not all brands have the same wire colors for the pump power block.

Orange = 230 VAC (common)

Yellow = 230VAC (switched) for 1st stage

Red = 230VAC (switched) for 2nd stage

**Relay #1 needed for temperature difference mode; both relays needed for flow mode.

Figure 2d: Wiring Diagram for heat pumps without an external compressor contactor (compressor relay is on the circuit board) and without an accessory relay -- see Note A, page 5



CAUTION: DO NOT CONNECT THE MAGNA GEO VARIABLE SPEED PUMP HIGH VOLTAGE TERMINALS TO THE "T" SIDE OF THE HEAT PUMP COMPRESSOR CONTACTOR. THE HIGH IN-RUSH CURRENT MAY CAUSE PREMATURE CONTACTOR FAILURE. ALWAYS CONNECT THE PUMP DIRECTLY TO THE MAINS OR TO THE "L" SIDE OF THE COMPRESSOR CONTACTOR. SEE APPENDIX C FOR MORE DETAILS.

INSTALLATION TIP

Geo-Flo offers a panel mount flow center option for pressurized flow centers and a variable speed kit for non-pressurized flow centers. Both products provide factory-wired and mounted controllers, as well as factory wired thermistors and flow sensor (if equipped). Field low voltage wiring simply involves running 4 conductor thermostat wiring between the heat pump and the flow center terminal block, greatly reducing installation time. In addition, all components necessary for the installation, including the hose kit, are part of the panel mount or flow center variable speed kit.

Wiring the Controller (One Flow Center / Two Heat Pumps)



WARNING: OPEN THE POWER SUPPLY DISCONNECT SWITCH AND SECURE IT IN AN OPEN POSITION PRIOR TO PERFORMING ELECTRICAL WORK. VERIFY THAT POWER HAS BEEN DISCONNECTED PRIOR TO WIRING THE CONTROLLER. FAILING TO SECURE THE ELECTRICAL SUPPLY COULD RESULT IN SERIOUS INJURY OR DEATH. THIS EQUIPMENT SHOULD BE INSTALLED AND SERVICED BY QUALIFIED PERSONNEL ONLY.

NOTE: The Magna GEO 32-140 motor requires no external protection. Wiring the Magna GEO directly to mains power is recommended. See Appendix C for more information.

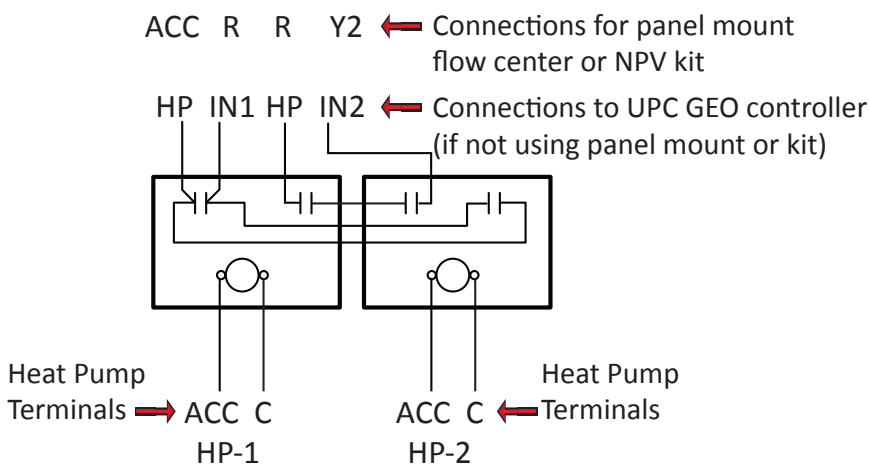

INPUTS		OUTPUTS	
HP-1	HP-2	HP IN1	HP IN2
ON	OFF	ON	OFF
OFF	ON	ON	OFF
ON	ON	ON	ON
OFF	OFF	OFF	OFF

ACC is accessory terminal (energized when compressor contactor coil is energized). If heat pump does not have an accessory terminal, consult Figures 2c and 2d.

Figure 3: Wiring Diagram for connecting two heat pumps to one variable speed flow center. See figures 4a and 4b for piping.

NOTES:

- A. Above wiring should be used with a flow sensor to avoid potential nuisance trips if one unit is in cooling and one is in heating or other temperature difference conditions (e.g. long runs of piping in the mechanical room, settling to room temp.).
- B. Set stage one flow between minimum and nominal full load flow rate of the larger unit. Set stage two flow between minimum and nominal flow for both units on full load. For example:
 - 4 ton and 3 ton heat pump
 - Minimum full load flow rates are 9 GPM (4 ton) and 7.5 GPM (3 ton); nominal flow rates are 12 GPM (4 ton) and 9 GPM (3 ton).
 - Stage one flow rate should be 9 to 12 GPM (between min. and nom. for 4 ton).
 - Stage two flow rate should be 16.5 to 21 GPM (between min. and nom. for both heat pumps).
 - A good compromise for this example would be 10 GPM on stage 1 and 19 GPM on stage 1.
- C. A zone valve is required at each unit to allow flow only through the heat pump running.

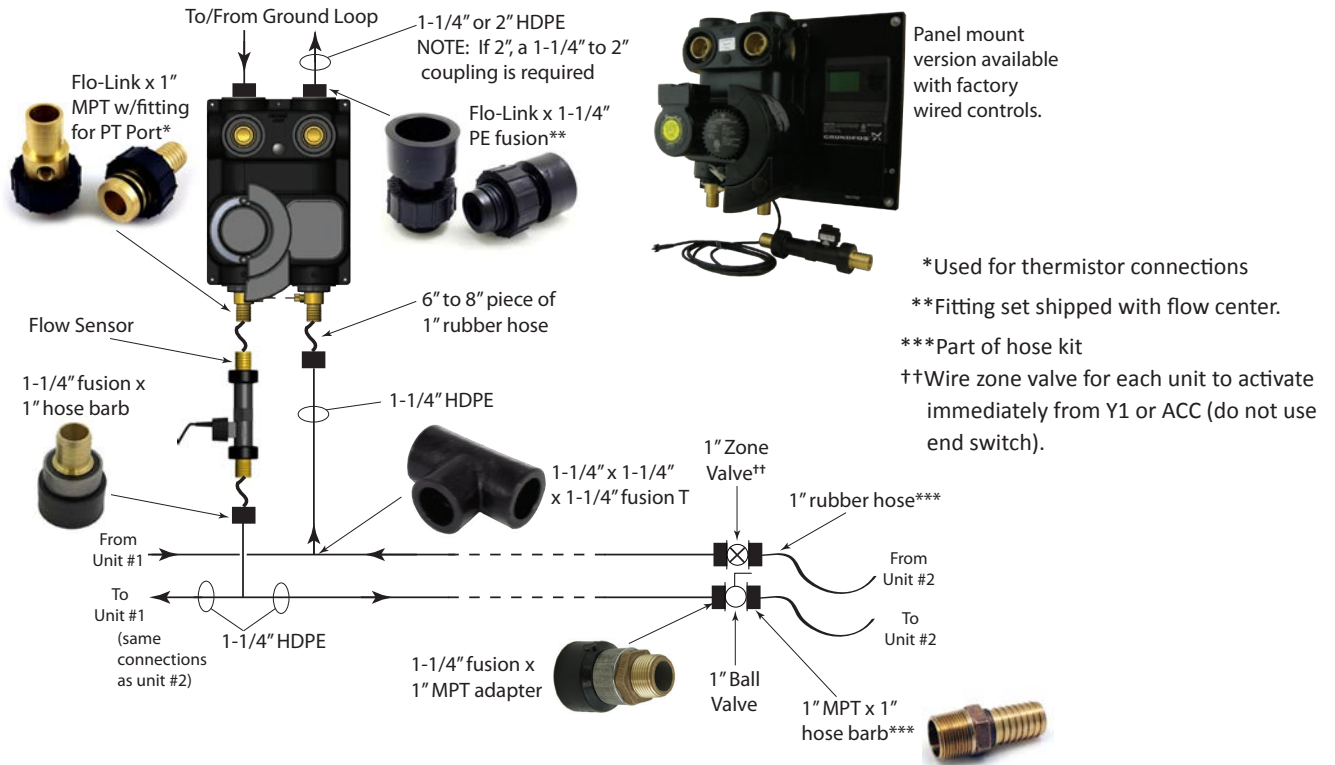

Figure 4a: Two Unit Piping Diagram: Pressurized Flow Center

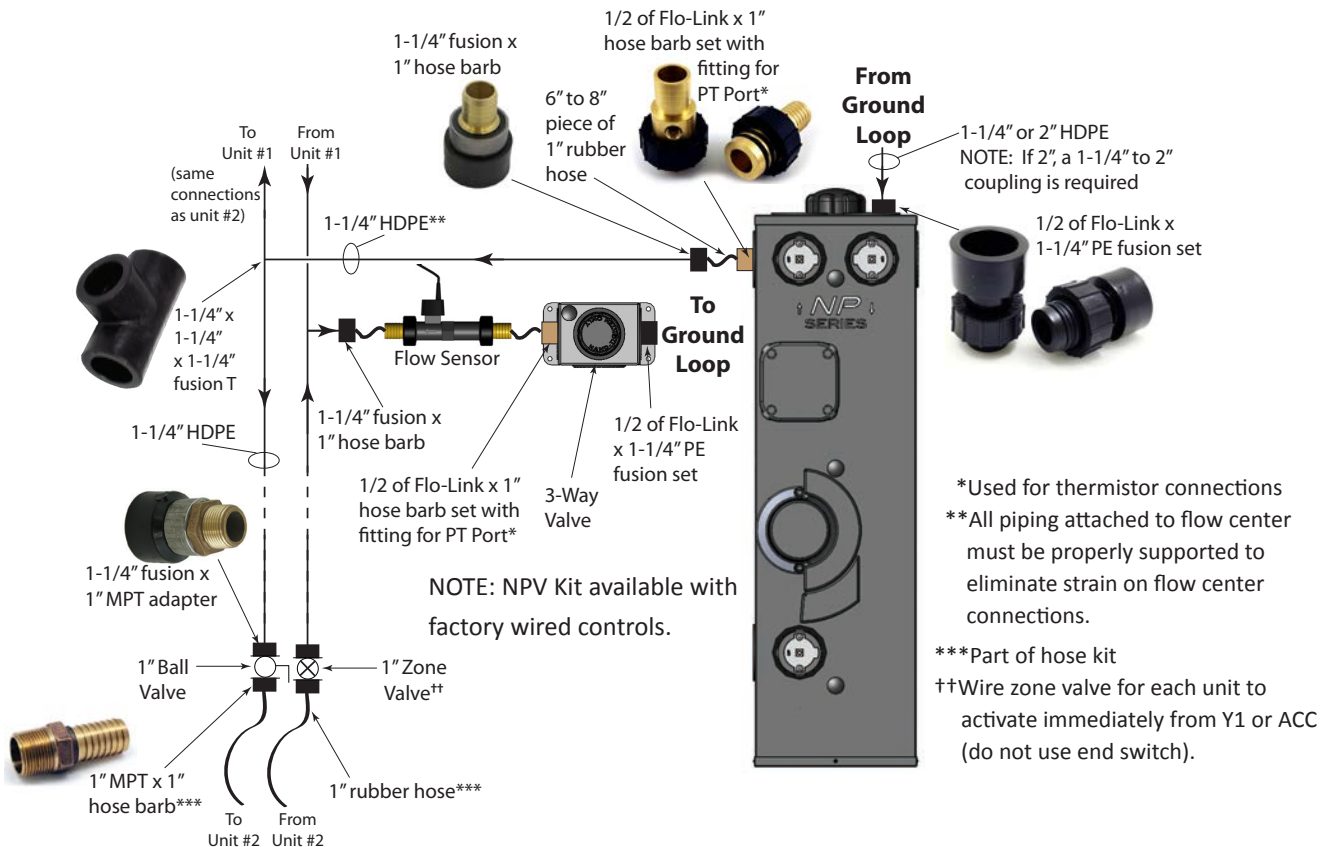

Figure 4b: Two Unit Piping Diagram: Non-Pressurized Flow Center

Wiring the Controller (0-10 VDC Output)



WARNING: OPEN THE POWER SUPPLY DISCONNECT SWITCH AND SECURE IT IN AN OPEN POSITION PRIOR TO PERFORMING ELECTRICAL WORK. VERIFY THAT POWER HAS BEEN DISCONNECTED PRIOR TO WIRING THE CONTROLLER. FAILING TO SECURE THE ELECTRICAL SUPPLY COULD RESULT IN SERIOUS INJURY OR DEATH. THIS EQUIPMENT SHOULD BE INSTALLED AND SERVICED BY QUALIFIED PERSONNEL ONLY.

NOTE: The Grundfos Magna3 (or other pump receiving 0-10 VDC output from this controller) must be powered independently. This controller is not designed to power the pump.

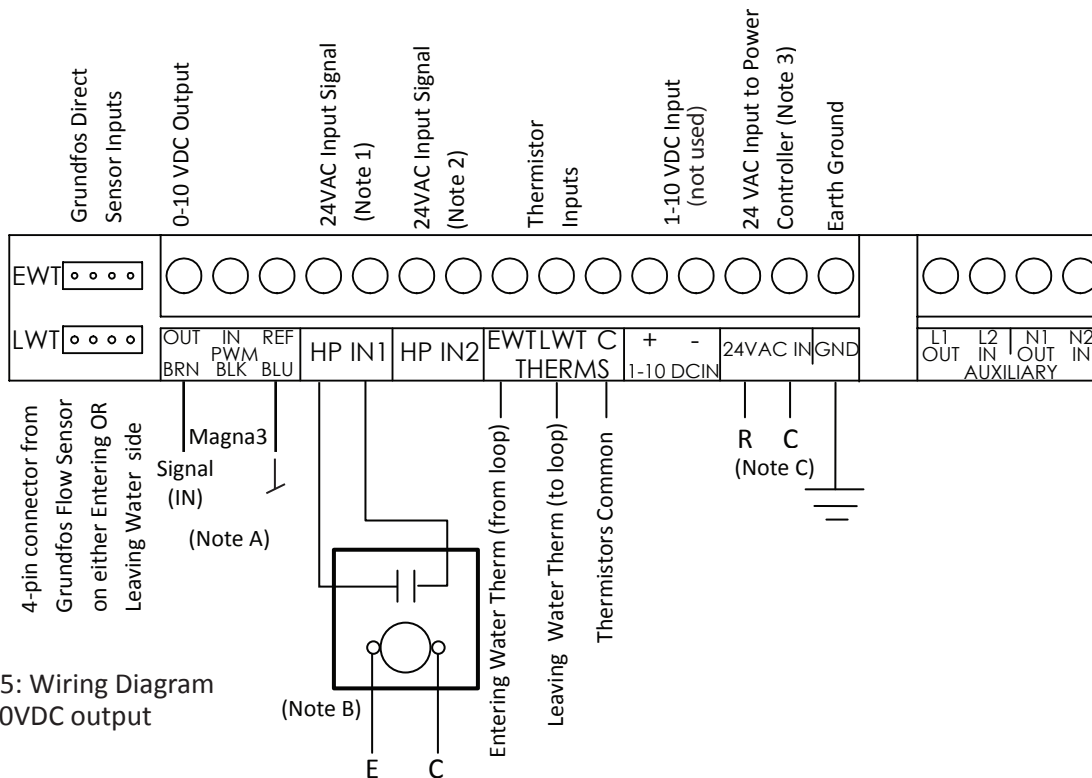

Figure 5: Wiring Diagram for 0-10VDC output

NOTES:

- A.** 0-10 VDC Output (labeled “PWM”): Connect 0-10 VDC output from the OUT (BRN) and REF (BLU) terminals to the pump being controlled (Grundfos Magna3 terminal connections shown above).
- B.** HP IN1: Used for pump enable. Left terminal receives 24 VAC input to activate controller based upon controller setting, flow rate or ΔT. Controller will send 0-10 VDC output to the pump to maintain flow rate or ΔT when enabled. If the application requires constant pump operation (or a minimum flow rate), terminals HP and IN1 should be jumpered to enable controller/pump continuous operation. **IMPORTANT:** If using 24 VAC from a nearby heat pump, some heat pump accessory relay contacts are not isolated from the 24 VAC heat pump transformer, and may create a “dirty” power signal, especially heat pumps with thermostat-controlled ECM fan motors (symptom includes variable speed pump not shutting off). An isolation relay as shown in Figure 5 will be required for these situations. Terminal E is 24 VAC; terminal C is common.
- C.** 24VAC IN: Left terminal connected to “R”; right terminal connected to “C” from external transformer or heat pump.

Setup

Quick Start Procedure

1. Press and hold the center button to enter Setup Menu (Fig. 6).
2. Select desired control mode (Item 4 in menu).
3. Enter desired flow rates or ΔT (Item 1 in menu).
4. Select sensors that have been installed (Item 2 in menu).
5. Enter media/antifreeze type and concentration (Item 3 in menu).
6. Select desired Lockout mode (Item 5 in menu).
7. Select desired output signal (Item 6 in menu) -- version 3.0 and higher only.

General Navigation

The menu items are navigated by using the + (up), - (down), and OK (center) buttons. Pressing the + and - buttons moves a triangular cursor up and down through the menu items, switches between the two Main pages, or increases or decreases a particular parameter. Pressing and holding the OK button for one second while on either Main page changes the display to the Setup Menu screen (unless the controller has been locked). Pressing and holding the OK button for one second from any screen other than Main returns the display to the previous screen. Pressing and quickly releasing the OK button scrolls through the menu options next to the cursor, or changes the cursor to a filled triangle which allows the + and - buttons to increase or decrease the parameter selected.

Main Page

The Main page provides information on the system (Figure 8). The screen shows whether there is a first or second stage call, pump operation ("Power Usage" for PWM controller output to pump or "Volts Output" for 0-10 VDC controller output), the control mode (Flow or ΔT), the flow rate or ΔT (depending on control method selected), and the system status. The System Status area provides information such as whether the system is running or stopped, whether one or two pumps are running, and any warnings or errors. Pressing the up or down arrow from the Main page changes the display to the Main-2 page which displays the EWT, LWT, Flow rate, and HE/HR. Note that parameters displayed depend on the sensors that are installed in the system. A VFS flow sensor and a thermistor must be installed to see all of the parameters.

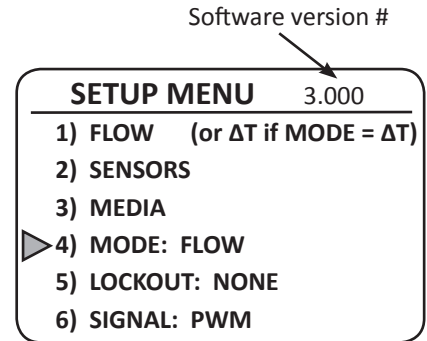

Figure 6: Setup Menu (Mode)

NOTE: Menu item 6 is only available for software version 3.0 and higher.



Figure 7: Navigation Buttons

HEAT PUMP STAGE1 OFF/ON STAGE2 OFF/ON	POWER USAGE (W) OR VOLTS OUTPUT
CONTROL MODE SYSTEM STATUS	FLOW RATE (GPM) OR ΔT ($^{\circ}$ F)

Figure 8: Main Page

NOTE: "VOLTS OUTPUT" is only available for software version 3.0 and higher.

EWT ($^{\circ}$ F)	LWT ($^{\circ}$ F)
HE/HR (KBTU/H)	FLOW RATE (GPM)

Figure 9: Main-2 Page

System Status

SYSTEM STATUS Display	Description
1 PUMP RUNNING	Magna GEO 32-140 is running
2 PUMPS RUNNING	Magna GEO 32-140 is running and relay energizes L1/N1 output to UPS26-99 (i.e. both pumps should run)
STOPPED	Neither pump is running
Warnings displayed in the System Status area are discussed in the Troubleshooting section of this document.	

NOTE: If system status display shows pump(s) running, but heat pump is not operating, check wiring vs. diagram on pages 5 to 7. Isolation may be required between ACC/Y2 and the controller.

Setup Menu

The Setup Menu page is accessed by pressing and holding the OK button for one second while on the Main page. Item 1) in the Setup Menu changes depending on which mode is selected and will always match the Mode listed in item 4 (Figure 10).

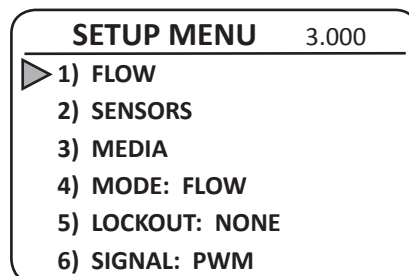

Figure 10: Setup Menu (Item 1)

NOTE: Menu item 6 is only available for software version 3.0 and higher.

Flow Configuration / Minimum Pump Speed %

The Flow Configuration menu (Figure 11) is accessed by selecting 1) FLOW from the Setup Menu when item 4) is set to FLOW. Separate flow rates for Stage 1 and Stage 2 operation can be specified. The flow rate specified for STAGE 1 will be applied when the controller receives a 24 VAC signal at the left HP IN1 terminal, or when a dry contact is made across the two HP IN1 terminals. The flow rate specified for STAGE 2 will be applied when the controller receives a 24 VAC signal at the left HP IN2 terminal, or when a dry contact is made across the two HP IN2 terminals. Press the OK button to select Item 1) STAGE 1 or Item 2) STAGE 2 and the +/- buttons to set the values.

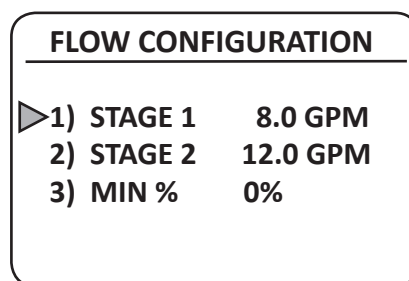

Figure 11: Flow Configuration

NOTE: Menu item 3 is only available for software version 3.0 and higher.

Item 3) MIN% in the Flow Configuration menu allows for a minimum pump speed percentage set point. Although not typically used for residential applications, the pump speed may be set to remain above a certain percentage RPM regardless of the flow rate setting for STAGE 1. To change minimum %, press the arrow down (-) button to select item 3). Press the OK button to select the MIN % menu (the triangle cursor will turn solid), and use the +/- buttons to set the value. Once set, press the OK button again to lock in the value.

ΔT Configuration / Minimum Pump Speed %

The ΔT Configuration menu (Figure 12) is accessed by selecting 1) ΔT from the Setup Menu when item 4) is set to ΔT. Separate ΔT values for heating and cooling operation can be specified. The Heating ΔT will be applied when the controller receives a 24VAC signal at the left HP IN1 terminal or the left HP IN2 terminal AND the EWT > LWT (i.e. heat is extracted from loop). The Cooling ΔT will be applied when the controller receives a 24VAC signal at the left HP IN1 terminal or the left HP IN2 terminal AND the LWT > EWT (i.e. heat is rejected to loop). A dry contact across the two terminals of HP IN1 or HP IN2 can be used as an alternative to providing a 24VAC signal.

Item 3) MIN% in the ΔT Configuration menu allows for a minimum pump speed percentage set point. Although not typically used for residential applications, the pump speed may be set to remain above a certain percentage RPM regardless of the ΔT setting for heating or cooling. To change minimum %, press the arrow down (-) button to select item 3). Press the OK button to select the MIN % menu (the triangle cursor will turn solid), and use the +/- buttons to set the value. Once set, press the OK button again to lock in the value.

Sensor Configuration

NOTE: Selecting the actual sensors installed in the system is critical to proper controller performance.

The Sensor Configuration menu (Figure 13) is accessed by selecting SENSORS from the SETUP menu. Items 1) and 2) are provided for the various Grundfos Vortex Flow Sensors available including VFS 1-20, VFS 2-40, VFS 5-100, VFS 10-200, and VFS 20-400. Items 3) and 4) are provided for 10K thermistors. The mapping of the sensors to the location on the controller circuit board is shown on the Figure 13 in brackets. To change the type of sensor, press the OK button to select the item (cursor becomes filled) and use the + and - buttons to select the sensor. The UPC-GEO will automatically recognize when a thermistor is connected to the EWT or LWT thermistor terminals.

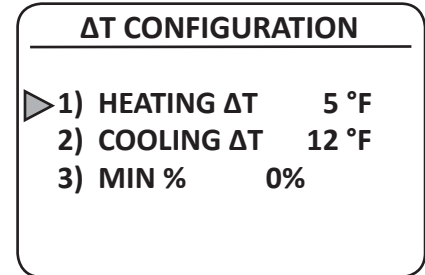

Figure 12: ΔT Configuration

NOTE: Menu item 3 is only available for software version 3.0 and higher.

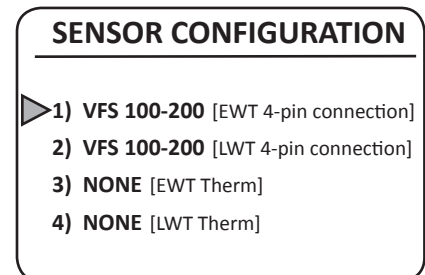

Figure 13: Sensor Configuration

Media Configuration

The Media Configuration menu (Figure 14) is accessed by selecting MEDIA from the SETUP menu. The Media Configuration page allows setting the type and percentage of antifreeze used in the ground loop system. The TYPE choices are ethanol, methanol, glycol, and none. The Media inputs only affect the HE/HR calculation.

NOTE: HE/HR is calculated as follows:

$$HE \text{ or } HR = \Delta T \times \text{Flow Rate (U.S. GPM)} \times \text{Fluid Factor}$$

where: ΔT = temperature difference between EWT and LWT

Fluid factor = adjustment for antifreeze (see appendix F)

Mode Setup

The UPC-GEO’s operating and control mode is set by moving the cursor to 4) MODE on the SETUP menu (Figure 15) and pressing the OK button until the desired mode is displayed. Item 1) in the menu will change to match the MODE. There are three modes available: 1) FLOW, 2) ΔT , and 3) METER. Flow mode provides pump control and feedback based on the desired flow rate for first and second stage operation. This mode requires the installation of a Grundfos VFS sensor. ΔT mode provides pump control and feedback based on desired differential temperature for heating and cooling operation, and requires the installation of thermistors. Meter mode provides a display of flow rate, entering and leaving fluid temperatures, and HE/HR depending on which sensors are installed. Meter mode **does not provide an output to control the pump(s)**, and only displays the Main-2 page.

Lockout Setup

There are three Lockout modes available that provide differing levels of security to the controller settings: 1) Screen, 2) Parameter, and 3) None. Screen lockout disables all display screen feedback. A controller in screen lockout mode will not respond to +, -, or OK button inputs and will display “PROTECTED” on the screen. Parameter lockout prevents access to the SETUP menu but the MAIN and MAIN-2 pages will be displayed as normal. The default lockout setting of NONE allows access to all the display screens and settings. The mode is selected by moving the cursor to Item 5) LOCKOUT in the Setup Menu and pressing the OK button until the desired mode is displayed.

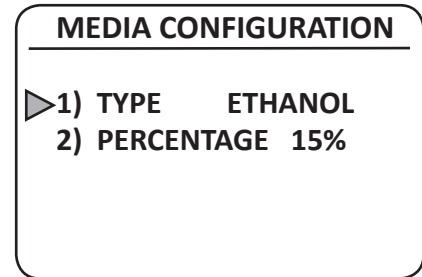

Figure 14: Media Configuration

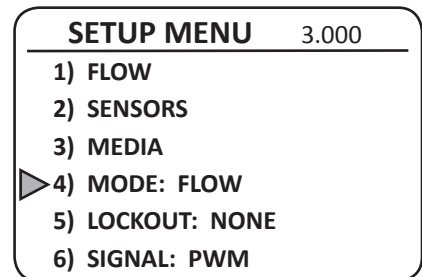

Figure 15: Mode Setup

NOTE: Menu item 6 is only available for software version 3.0 and higher.

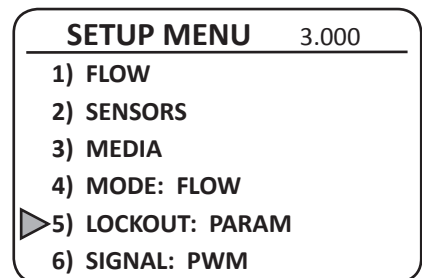

Figure 16: Mode Setup

NOTES:

1. To unlock the UPC-GEO, hold down the OK button for 10 seconds (software version 3.0 and later) or 30 seconds (previous versions).
2. Menu item 6 is only available for software version 3.0 and higher.

Controller Output Signal Setup

There are two controller output modes available that change the output based upon the variable speed pump connected: 1) PWM, and 2) 0-10 VDC. The default setting is PWM, which is used for the Grundfos Magna GEO variable speed pump. The 0-10 VDC setting is used for Grundfos Magna3 or other pumps that require a 0-10 VDC input signal. The mode is selected by moving the cursor to Item 6) SIGNAL in the Setup Menu and pressing the OK button until the desired mode is displayed. Menu choice 6) is only available for controllers with software version 3.0 and higher.

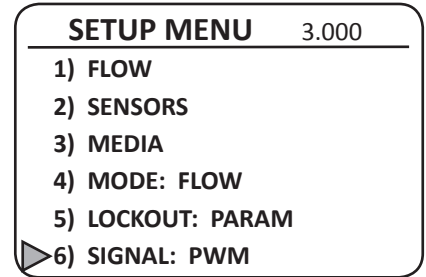

Figure 17: Output Setup

NOTE: Menu item 6 is only available for software version 3.0 and higher.

Troubleshooting

Screen Color	Action / Display	Indication	Possible Cause / Solution
Blue backlight	Any button is pressed	Blue backlight comes on for 30 seconds when a button is pressed.	N/A
No light or blue backlight	Display = "RUNNING"	Normal operation	N/A
	Display = "1 PUMP"		
	Display = "2 PUMPS"		
	Display = "STOPPED"		
Red	Display = "NO SENSOR"	No flow sensor connected when in flow mode; no thermistor connected when in ΔT mode.	<ol style="list-style-type: none"> Flow sensor not plugged in. Plug in sensor; check installation and wiring. Flow sensor not set up in sensor configuration menu. Select proper sensors and EWT/LWT location in sensor configuration menu. Missing thermistors. Check thermistor wiring at EWT, LWT, and C terminals on UPC-GEO circuit board.
	Display = "NO PUMP"	Controller does not detect a Magna GEO (var. spd.) pump attached. Could also indicate no power to pump.	<ol style="list-style-type: none"> PWM Cable not attached to pump or controller. Check PWM cable at pump and controller. Magna GEO does not have power. Provide 230VAC power to Magna GEO. Check Line and Neutral connections on 230V power. If the pump is wired to the "T" side of the contactor, the pump should be rewired to the "L" side of the contactor.
	Display = "BLOCKED"	Magna GEO feedback signal "reports" to controller that rotor is blocked.	Debris is blocking pump rotor. Remove pump motor and clean debris. Replace pump if necessary.
	Display = "LOVOLT F"	Magna GEO feedback signal "reports" to controller that voltage is not sufficient to run.	Incorrect power supplied to pump. Supply correct input to pump.
	Display = "RPM SENSOR"	Magna GEO feedback signal "reports" to controller that motor has RPM sensor fault. Pump runs at reduced speed.	Failed RPM sensor. Replace pump.

- continues -

Troubleshooting (continued)

Screen Color	Action / Display	Indication	Possible Cause / Solution
Yellow	Display = "LOWVOLT W"	Magna GEO feedback signal "reports" to controller that motor has low voltage, but it is still able to running (yellow indicates a warning). Pump performance is reduced.	Incorrect power supplied to pump. Supply correct input to pump.
	Display = "FLOW SET-POINT"	Displayed when the pump(s) are unable to deliver the flow rate necessary to achieve the set point (flow or ΔT) input into the UPC-GEO (i.e. the pumping system is running at full speed and cannot satisfy the user's request).	<ol style="list-style-type: none"> 1. Incorrect flow rate or ΔT value entered into UPC-GEO. Enter correct flow rate or ΔT values into UPC-GEO. 2. Pump system undersized for installed piping/heat pump system. Reduce system head loss. Add an additional pump to the system.

Additional Troubleshooting

Problem	Possible Cause	Solution
Magna GEO var. speed pump runs continuously at full speed and does not respond to controller inputs.	Loss of communication with controller. Controller should report "No Pump" in Status area.	Check PWM cable connection at pump and at controller. Or, may require isolation relay.
Control displays "2 PUMPS RUNNING" but UPS26-99 will not run.	<p>No 230V input power at L2/N2 IN (i.e. one leg of the 230V input is disconnected).</p> <p>No 230V output power at L1/N1 OUT (i.e. one leg of the 230V output is disconnected).</p>	<p>Correct input/output wiring.</p> <p>The relay L1/N1 and L2/N2 are rated for 120/208-230V. If a single leg (Line or Neutral) of the 230V power is connected to the L2/N2 IN, the relay will energize the L1/N1 OUT terminals but the 230V UPS26-99 will not run.</p>
	UPS26-99 failure.	<p>Disconnect power. Isolate UPS26-99 by closing service/flush valves. Verify UPS26-99 impeller spins free by removing bleed screw with a large flathead screwdriver and attempt to rotate the pump's shaft with a small flathead screwdriver. Note that removing bleed screw will result in fluid/pressure loss in system so be prepared with a bucket and/or towels. If the impeller spins, replace bleed screw, open service/flush valves, re-pressurize system, and re-connect power. If pump then runs, loosen bleed screw and allow a few drops of water to seep out to ensure there is no air trapped in the pump. If impeller does not turn or the above procedure fails, replace pump motor.</p> <p>- continues -</p>

Additional Troubleshooting (continued)

Problem	Possible Cause	Solution
Controller will not energize the UPS26-99.	No 208-230V input power at L2/N2 IN. No 208-230V output power at L1/N1 OUT.	Correct input/output wiring.
	UP26-99 not required to meet the demand (set point for flow or ΔT).	To check UPS26-99 operation, increase the demand (i.e. required flow rate) incrementally and monitor the display. When the pump is at or near its maximum performance level the power will read about 230W. A higher demand will result in the relay energizing L1/N1 OUT terminals (UPS26-99) and/or a "FLOW SETPOINT" warning.
	Bad relay on controller PCB.	Replace controller.
Sporadic flow rate display on controller.	Grundfos VFS Sensor/ Sensor tube mounted incorrectly. Plumbing disturbance in front of entrance to flow tube. Air in loop. Sensor dirty or defective.	Check direction of flow arrow on sensor tube body and re-plumb if necessary. Re-plumb to remove disturbance. Flush loop. Remove sensor and clear debris. Replace sensor if necessary.
Controller displays "PROTECTED" and will not respond to button inputs.	Controller Lockout mode has been set to SCREEN.	Change Lockout mode to None or Parameter. See Lockout Setup section for more information.
Controller will not respond to button inputs when trying to change flow rate, ΔT , etc.	Controller Lockout mode has been set to PARAM.	Change Lockout mode to None. See Lockout Setup section for more information.
Controller displays "1 PUMP RUNNING" or "2 PUMPS RUNNING," but heat pump is off.	Controller may be connected directly to thermostat. In some cases, backfeed voltage could cause pump(s) to run.	Wire controller as shown on pages 5 & 6 with isolation between ACC and Y2.
Pump continually overshoots and undershoots set point in ΔT mode (i.e. pump ramps up and nearly stops).	Small pump speed changes result in large ΔT swings at low flow rates.	Increase MIN % to prevent pump from stopping.

Appendix A: Sensor Kit Descriptions

The following information provides descriptions of currently available controller kits. Although both kits work well, there is an advantage to installing the flow and temperature kit, as the ability to directly read heat of extraction and heat of rejection makes start up and troubleshooting much easier.

1. Controller kit (P/N 3698 & 3766*), Flow and Temperature: This kit allows the installer to control pump speed based upon flow rate or temperature difference (ΔT). The display will show heat pump operating stage, EWT, LWT, ΔT , flow rate, pumping Watts, and heat of extraction/rejection (Figure 18).

(1)	Controller with wall anchor kit
(1)	PWM controller-to-pump cable, 10'
(1)	VFS10-200 Flow tube, sensor, cable, and seals
(2)	Brass adapters, 1" Hose Barb X 10-200 Flow Tube
(2)	G1-1/4 Union nuts (for Flow Tube/Adapters)
(4)	Hose clamps, stainless steel
(2)	10k Thermistors, 1/4" MPT brass connection
(2)	SPDT Isolation Relay (for ACC & Y2 input)

***Note:** P/N 3766 includes (2) 1" PVC glue adapters instead of 1" hose barb adapters. All other components are the same as P/N 3698).



Figure 18: Flow and Temperature Kit (P/N 3698)

2. Controller kit (P/N 3697), Temperature: This kit allows the installer to control pump speed based upon temperature difference (ΔT). The display will show heat pump ON/OFF, EWT, LWT, ΔT , and pumping Watts. Flow rate and heat of extraction/rejection will not be displayed (Figure 19).

(1)	Controller with wall anchor kit
(1)	PWM controller-to-pump cable, 10'
(4)	Hose clamps, stainless steel
(2)	10k Thermistors, 1/4" MPT brass connection
(1)	SPDT Isolation Relay (for ACC & Y2 input)



Figure 19: Temperature Kit (P/N 3697)

Appendix B: Installing Sensors

Thermistor Installation

Install thermistors in any 1/4" NPT Female port using a quality thread sealing compound (pipe dope). Be sure to insulate the entire fitting/pipe/thermistor to prevent conductive heat transfer from affecting the thermistor reading. Adding additional wire to the thermistor leads is acceptable since the resistance of the thermistor is much greater than the resistance of the additional wiring. Figure 20 provides several examples of thermistor to fitting assemblies.

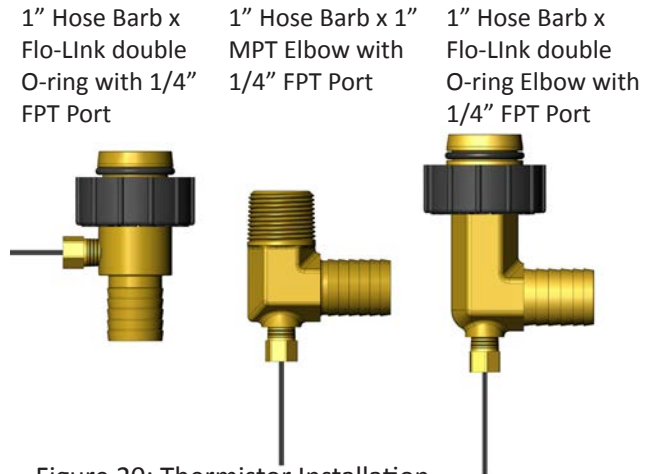

Figure 20: Thermistor Installation

Grundfos VFS Sensor Installation

Install the VFS sensor and flow tube by utilizing the 1" hose barb transition fittings. Allow 6-10" of 1" rubber hose in front of and behind the flow tube. Be sure that there are no sharp bends/elbows directly in front of or behind the sensor. **Verify that the arrow on the flow tube matches the pumping direction or the sensor will not perform correctly.** The sensor can be placed on the entering water or leaving water side of the heat pump. See Figure 21.

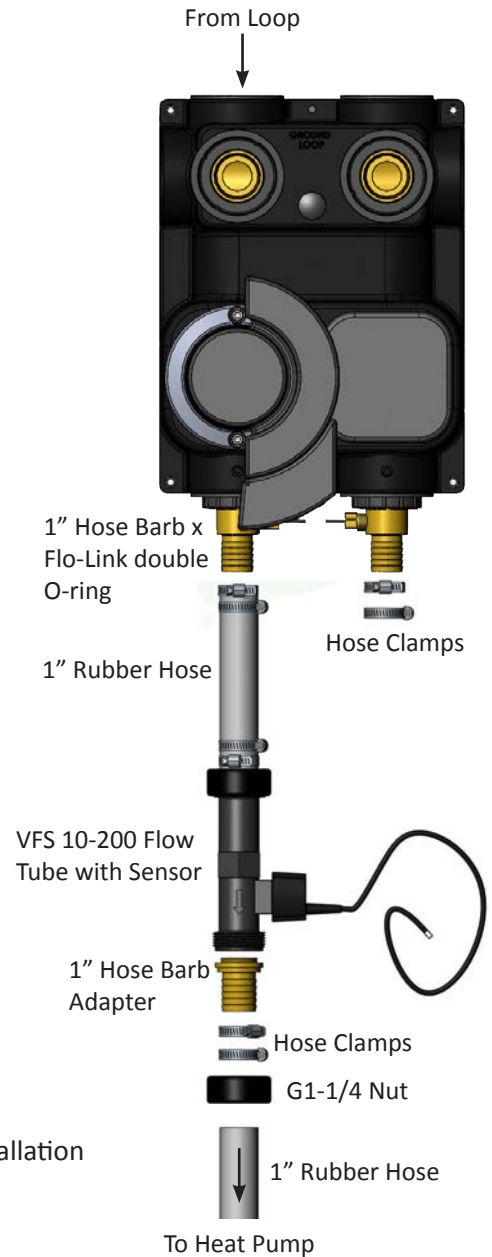

Figure 21: Flow Sensor Installation

Appendix C: Thermistor Temperature/Resistance Chart

RESISTANCE VS. TEMPERATURE CHART

10K THERMISTOR*, UPC GEO

Temp (°F)	Temp (°C)	Resistance (Ω)	Temp (°F)	Temp (°C)	Resistance (Ω)	Temp (°F)	Temp (°C)	Resistance (Ω)
20.0	-6.7	46,195	61.0	16.1	14,930	103.0	39.5	5,445
21.0	-6.1	44,863	62.0	16.7	14,556	104.0	40.0	5,326
22.0	-5.6	43,574	63.0	17.2	14,192	105.0	40.6	5,210
23.0	-5.0	42,326	64.0	17.8	13,839	106.0	41.1	5,096
24.0	-4.5	41,119	65.0	18.4	13,464	107.0	41.7	4,986
25.0	-3.9	39,949	66.0	18.9	13,131	108.0	42.2	4,878
26.0	-3.4	38,817	67.0	19.5	12,807	109.0	42.8	4,772
27.0	-2.8	37,720	68.0	20.0	12,493	110.0	43.4	4,661
28.0	-2.3	36,658	69.0	20.6	12,186	111.0	43.9	4,561
28.0	-2.2	36,564	70.0	21.1	11,889	112.0	44.5	4,463
29.0	-1.7	35,538	71.0	21.7	11,599	113.0	45.0	4,368
30.0	-1.1	34,545	72.0	22.2	11,318	114.0	45.6	4,275
31.0	-0.6	33,582	73.0	22.8	11,044	115.0	46.1	4,185
32.0	0.0	32,650	74.0	23.4	10,754	116.0	46.7	4,096
33.0	0.6	31,747	75.0	23.9	10,496	117.0	47.2	4,010
34.0	1.1	30,872	76.0	24.5	10,245	118.0	47.8	3,926
35.0	1.7	30,024	77.0	25.0	10,000	119.0	48.4	3,836
36.0	2.2	29,203	78.0	25.6	9,762	120.0	48.9	3,756
37.0	2.8	28,406	79.0	26.1	9,531			
38.0	3.4	27,565	80.0	26.7	9,305			
39.0	3.9	26,818	81.0	27.2	9,086			
40.0	4.5	26,094	82.0	27.8	8,872			
41.0	5.0	25,392	83.0	28.4	8,646			
42.0	5.6	24,711	84.0	28.9	8,444			
43.0	6.1	24,051	85.0	29.5	8,248			
44.0	6.7	23,411	86.0	30.0	8,057			
45.0	7.2	22,789	87.0	30.6	7,870			
46.0	7.8	22,186	88.0	31.1	7,689			
47.0	8.4	21,549	89.0	31.7	7,512			
48.0	8.9	20,983	90.0	32.2	7,340			
49.0	9.5	20,434	91.0	32.8	7,173			
50.0	10.0	19,901	92.0	33.4	6,995			
51.0	10.6	19,383	93.0	33.9	6,836			
52.0	11.1	18,881	94.0	34.5	6,682			
53.0	11.7	18,393	95.0	35.0	6,531			
54.0	12.2	17,919	96.0	35.6	6,384			
55.0	12.8	17,459	97.0	36.1	6,241			
56.0	13.4	16,973	98.0	36.7	6,102			
57.0	13.9	16,540	99.0	37.2	5,966			
58.0	14.5	16,120	100.0	37.8	5,834			
59.0	15.0	15,712	101.0	38.4	5,693			
60.0	15.6	15,315	102.0	38.9	5,568			

*10k resistor is 10kΩ at 25°C (77°F). Resistance goes down as temperature goes up.

Appendix D: Important Power Considerations

Grundfos recommends that the Magna GEO pump be wired directly to the mains power supply.

NOTE: Connecting the pump high voltage to the “T” side of the heat pump compressor contactor could cause premature contactor failure due to contact pitting.

The Magna GEO motor is controlled by a small frequency converter, which converts the power supply to DC voltage. Therefore, the 230 VAC mains voltage must be converted to DC voltage before the frequency converter can control the motor. The conversion is accomplished with a rectifier and a capacitor. The load of an ECM pump behaves as a capacitive load and not as a motor load like a standard pump. When turning the power supply on, the capacitor will act as a short circuit (as it is “empty” – it has not been charged) and therefore the current is only limited by the sum of resistance in the NTC resistor and the resistance in the coil in the mains filter. If the power is turned on when the supply voltage is at its highest point, the in-rush current will become much higher than the rated current, but only for a very short period of time (less than 0.0015 seconds, 1.5 msec). After this period of time, the current will drop to the rated current.



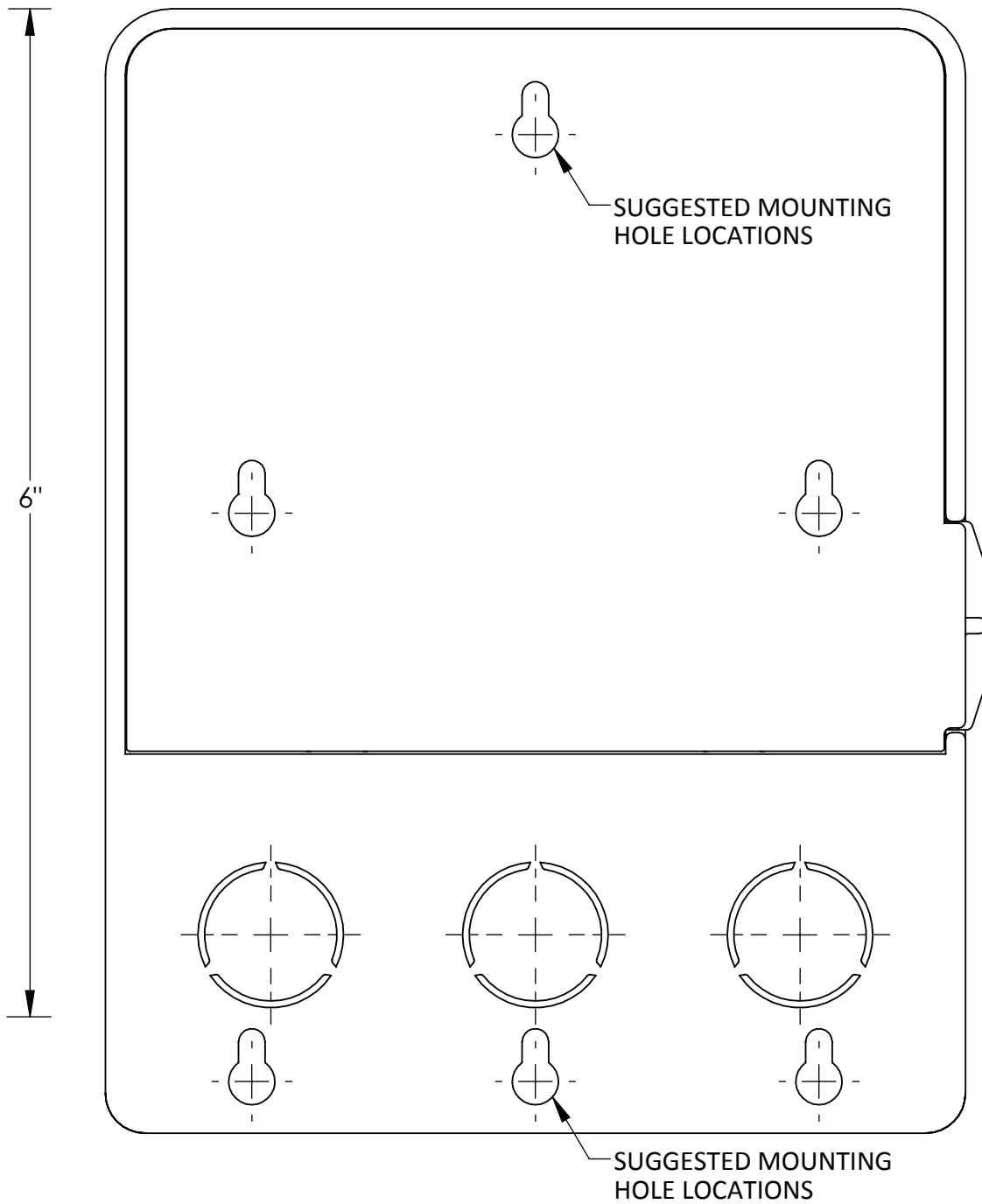

If the pump is powered on and off by an external relay, the contact material of the relay must be capable of higher in-rush currents. Grundfos recommends using a minimum 16 Amp relay for 230 VAC switched voltage, and a minimum of 250,000 electrical operation cycles at 4.0 Amps. A typical example is the Omron G7L general purpose relay. *There is no advantage in switching the pump power on and off with a relay, since the UPC Geo controller turns the pump on and off with the low voltage connection.* However, if required, special attention should be given to selecting a relay that meets the Grundfos recommendations.

Appendix E: Controller Mounting Template

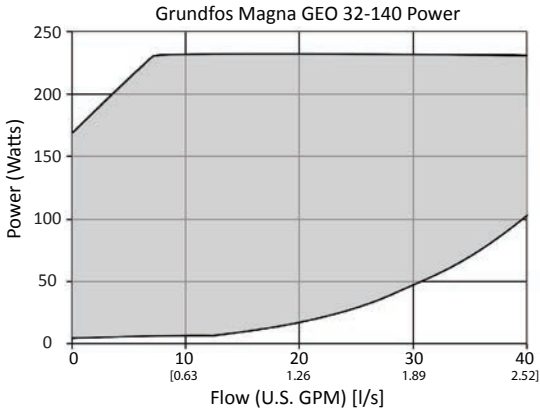
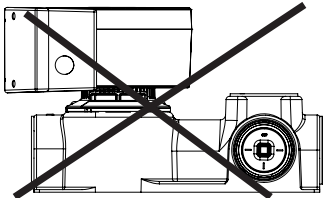
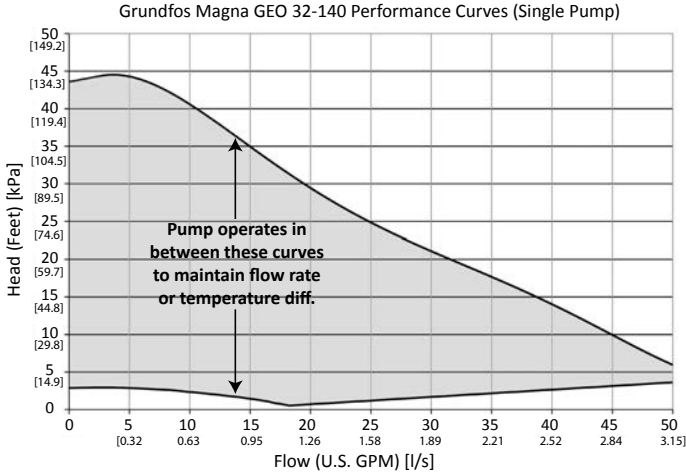
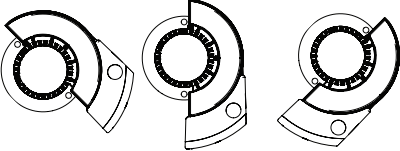

This document must be printed full-scale to properly mark the mounting-hole locations. The Page Scaling in the Print dialog box in Adobe Acrobat must be set to None. The 6-inch line can be used as reference to ensure the document has been printed full-scale.

Appendix F1: Pressurized Variable Speed Flow Center Submittals

		<h3>Submittal Data</h3> <p>FLV Series Variable Speed Pressurized Flow Center, Single Pump</p>
		Project Name:
		Contractor:
		Engineer:
		Order Number:
		Additional Information:
<h3>Technical Data</h3>		
Circulator:	Grundfos Magna GEO 32-140 variable speed	Max. Fluid Temperature: 140°F [60°C] Min. Fluid Temperature: 20°F [-7°C] Max. Oper. Press.: 145 psi [1 Mpa] Min. Operating Press.: 1.3 psi [9 kPa] Max. Ambient Air Temp: 104°F [40°C]
Cabinet:	High Impact Polystyrene plastic	
Insulation:	CFC-free, polyurethane foam	
Valves:	1" Full-port, 3-Way, 4-Position flushing and isolation/service valve, Brass body and spool, NBR seals, stainless steel retaining ring.	
<h3>Electrical and Power Data</h3> <p>Motor: 208-230V, 50/60 Hz, single phase, 2-pole, ETL_{C/US} approved (meets UL and CSA requirements), electronically protected, insulation class F, 0.09 to 1.7 Amps (at 230V)</p>		<h3>Approved Antifreeze</h3> <p>Propylene Glycol Ethanol Methanol</p>
 <p style="text-align: center;">Grundfos Magna GEO 32-140 Power</p> <p>Power (Watts) vs Flow (U.S. GPM) [l/s]</p>		<h3>Mounting</h3> <p>Flow Center is designed for indoor installation only.</p> <p>Flow Center must be installed with the pump's motor shaft horizontal.</p> <p>Do not install flow center with the pump's motor shaft vertical.</p> 
<h3>Pump Performance Curves</h3>  <p style="text-align: center;">Grundfos Magna GEO 32-140 Performance Curves (Single Pump)</p> <p>Head (Feet) [kPa] vs Flow (U.S. GPM) [l/s]</p> <p style="text-align: center;">Pump operates in between these curves to maintain flow rate or temperature diff.</p>		<p>The terminal box should be located in one of the following orientations:</p> 
<p>Curves are manufacturer's reported averages using water at 68°F [20°F].</p>		 <p>GEO-FLO PRODUCTS CORPORATION 905 Williams Park Drive Bedford, IN 47421 Phone: 812-275-8513 Fax: 812-275-8523 www.geo-flo.com</p>

Appendix F1: Pressurized Variable Speed Flow Center Submittals

Dimensional Data

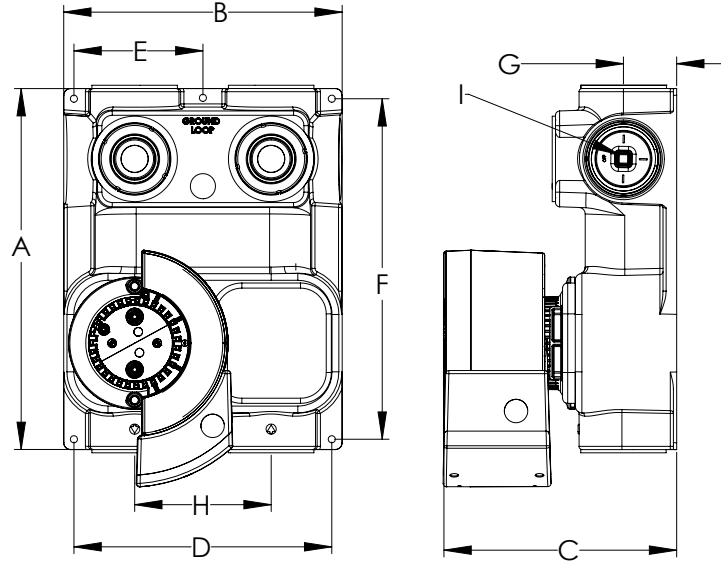









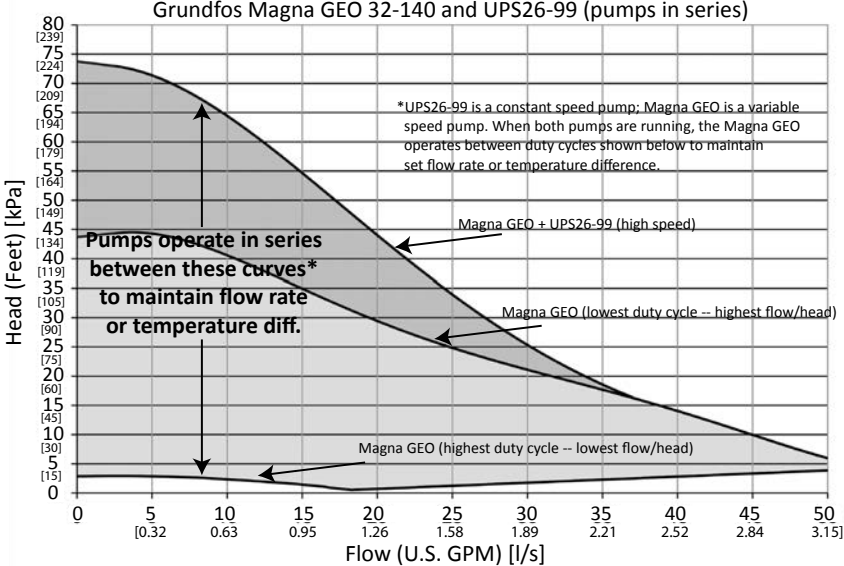
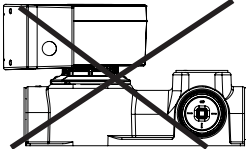

	A	B	C	D	E	F	G	H	I	WEIGHT	
Inches	13-1/4	10-3/16	8-1/2	9-7/16	4-3/4	12-1.2	2	5	3/8" DRIVE SOCKET	LBS	KG
CM	33.6	25.9	21.6	24.0	12.0	31.7	5.0	12.7		26	12

Fluid connections are Flo-Link™ double O-ring style. Transition fittings are not included with the flow center packaging. Typically, PE fusion x Flo-Link is used on the ground loop connections. A Geo-Flo hose kit designed for Flo-Link connections includes transition fittings for heat pump connections.

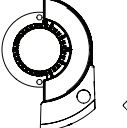

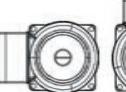
GEO-FLO PRODUCTS CORPORATION
 905 Williams Park Drive
 Bedford, IN 47421
 Phone: 812-275-8513 Fax: 812-275-8523
www.geo-flo.com

Appendix F1: Pressurized Variable Speed Flow Center Submittals

	<h3>Submittal Data</h3> <p>FLV Series Variable Speed Pressurized Flow Center, Double Pump</p>																															
	Project Name:																															
	Contractor:																															
	Engineer:																															
	Order Number:																															
	Additional Information:																															
<h3>Technical Data</h3> <table style="width: 100%; border: none;"> <tr> <td style="width: 15%; border: none;">Circulators:</td> <td style="border: none;">Grundfos UPS26-99 & Magna GEO variable spd. (requires controller)</td> <td style="border: none;">Max. Fluid Temperature: 140°F [60°C]</td> </tr> <tr> <td style="border: none;">Cabinet:</td> <td style="border: none;">High Impact Polystyrene plastic</td> <td style="border: none;">Min. Fluid Temperature: 20°F [-7°C]</td> </tr> <tr> <td style="border: none;">Insulation:</td> <td style="border: none;">CFC-free, polyurethane foam</td> <td style="border: none;">Max. Oper. Press.: 145 psi [1 Mpa]</td> </tr> <tr> <td style="border: none;">Valves:</td> <td style="border: none;">1" Full-port, 3-Way, 4-Position flushing and isolation/service valve, Brass body and spool, NBR seals, stainless steel retaining ring.</td> <td style="border: none;">Min. Operating Press.: 1.3 psi [9 kPa]</td> </tr> <tr> <td style="border: none;"></td> <td style="border: none;"></td> <td style="border: none;">Max. Ambient Air Temp: 104°F [40°C]</td> </tr> </table>			Circulators:	Grundfos UPS26-99 & Magna GEO variable spd. (requires controller)	Max. Fluid Temperature: 140°F [60°C]	Cabinet:	High Impact Polystyrene plastic	Min. Fluid Temperature: 20°F [-7°C]	Insulation:	CFC-free, polyurethane foam	Max. Oper. Press.: 145 psi [1 Mpa]	Valves:	1" Full-port, 3-Way, 4-Position flushing and isolation/service valve, Brass body and spool, NBR seals, stainless steel retaining ring.	Min. Operating Press.: 1.3 psi [9 kPa]			Max. Ambient Air Temp: 104°F [40°C]															
Circulators:	Grundfos UPS26-99 & Magna GEO variable spd. (requires controller)	Max. Fluid Temperature: 140°F [60°C]																														
Cabinet:	High Impact Polystyrene plastic	Min. Fluid Temperature: 20°F [-7°C]																														
Insulation:	CFC-free, polyurethane foam	Max. Oper. Press.: 145 psi [1 Mpa]																														
Valves:	1" Full-port, 3-Way, 4-Position flushing and isolation/service valve, Brass body and spool, NBR seals, stainless steel retaining ring.	Min. Operating Press.: 1.3 psi [9 kPa]																														
		Max. Ambient Air Temp: 104°F [40°C]																														
<h3>Electrical Data</h3> <p>UPS26-99 motor: 208-230V, 60 Hz, single phase, 2-pole UL and CSA approved, internal thermal overload protection, insulation class F, three speed Magna GEO motor: 208-230V, 50/60 Hz, single phase, 2-pole, ETL_{C/US} approved (meets UL and CSA requirements), electronically protected, insulation class F, variable speed</p> <table border="1" style="width: 100%; border-collapse: collapse; text-align: center;"> <thead> <tr> <th>Pump Motor</th> <th>Speed</th> <th>Nominal HP</th> <th>Volts</th> <th>Amps @ 230V*</th> <th>Watts @ 230V*</th> <th>Capacitor</th> <th>Pump Housing (Volute)</th> </tr> </thead> <tbody> <tr> <td rowspan="3">UPS26-99</td> <td>High</td> <td rowspan="3">1/6</td> <td rowspan="3">208-230</td> <td>0.9</td> <td>196</td> <td rowspan="3">5µF/400V</td> <td rowspan="3">Cast Iron</td> </tr> <tr> <td>Medium</td> <td>0.8</td> <td>179</td> </tr> <tr> <td>Low</td> <td>0.7</td> <td>150</td> </tr> <tr> <td>Magna GEO</td> <td>Variable</td> <td>1/6</td> <td>208-230</td> <td>0.09 to 1.7</td> <td>5 to 230</td> <td>N/A</td> <td>Cast Iron</td> </tr> </tbody> </table> <p><small>*Data is maximum for UPS26-99; Magna GEO varies with RPM.</small></p>		Pump Motor	Speed	Nominal HP	Volts	Amps @ 230V*	Watts @ 230V*	Capacitor	Pump Housing (Volute)	UPS26-99	High	1/6	208-230	0.9	196	5µF/400V	Cast Iron	Medium	0.8	179	Low	0.7	150	Magna GEO	Variable	1/6	208-230	0.09 to 1.7	5 to 230	N/A	Cast Iron	<h3>Approved Antifreeze</h3> <p>Propylene Glycol Ethanol Methanol</p>
Pump Motor	Speed	Nominal HP	Volts	Amps @ 230V*	Watts @ 230V*	Capacitor	Pump Housing (Volute)																									
UPS26-99	High	1/6	208-230	0.9	196	5µF/400V	Cast Iron																									
	Medium			0.8	179																											
	Low			0.7	150																											
Magna GEO	Variable	1/6	208-230	0.09 to 1.7	5 to 230	N/A	Cast Iron																									
<h3>Pump Performance Curves</h3> <div style="text-align: center;"> <p>Grundfos Magna GEO 32-140 and UPS26-99 (pumps in series)</p>  <p style="font-size: small;">*UPS26-99 is a constant speed pump; Magna GEO is a variable speed pump. When both pumps are running, the Magna GEO operates between duty cycles shown below to maintain set flow rate or temperature difference.</p> </div>		<h3>Mounting</h3> <p>Flow Center is designed for indoor installation only.</p> <p>Flow Center must be installed with the pump's motor shaft horizontal.</p> <p>Do not install flow center with the pump's motor shaft vertical.</p> <div style="text-align: center;">  </div> <p>The terminal box should be located in one of the following orientations:</p> <div style="display: flex; justify-content: space-around; align-items: center;"> <div style="text-align: center;">  Magna GEO </div> <div style="text-align: center;">  Magna GEO </div> <div style="text-align: center;">  Magna GEO </div> </div> <div style="text-align: center; margin-top: 10px;">  UPS26-99   </div>																														
<p>Curves are manufacturer's reported averages using water at 68°F [20°F].</p>		 <p>GEO-FLO PRODUCTS CORPORATION 905 Williams Park Drive Bedford, IN 47421 Phone: 812-275-8513 Fax: 812-275-8523 www.geo-flo.com</p>																														

Appendix F1: Pressurized Variable Speed Flow Center Submittals

Pump Power Curves

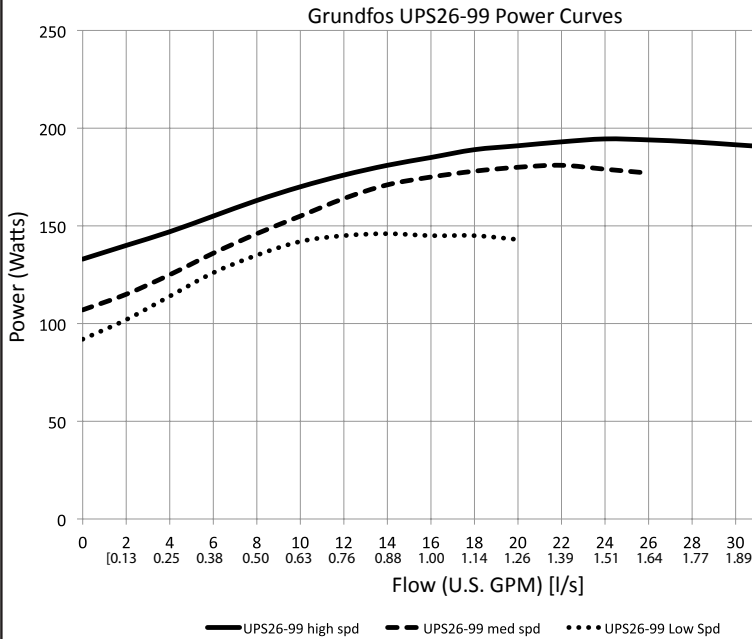

NOTES: The Magna GEO (variable speed) pump adjusts speed (when used with controller) to maintain flow rate or temperature difference. The controller energizes the constant speed pump (UPS26-99) when the Magna GEO cannot meet setpoint, and adjusts the Magna GEO pump accordingly. Total flow center Watts equals constant speed pump Watts plus Magna GEO Watts at design conditions. For Watts based upon a specific flow rate and pressure drop, go to www.geo-flo.com, and use the pump sizing calculator.

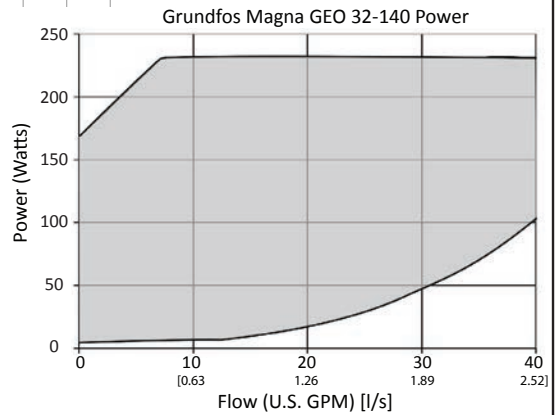

Dimensional Data

	A	B	C	D	E	F	G	H	I	WEIGHT	
Inches	13-1/4	10-3/16	8-1/2	9-7/16	4-3/4	12-1/2	2	5	3/8" DRIVE SOCKET	LBS	KG
CM	33.6	25.9	21.6	24.0	12.0	31.7	5.0	12.7		30.0	13.6

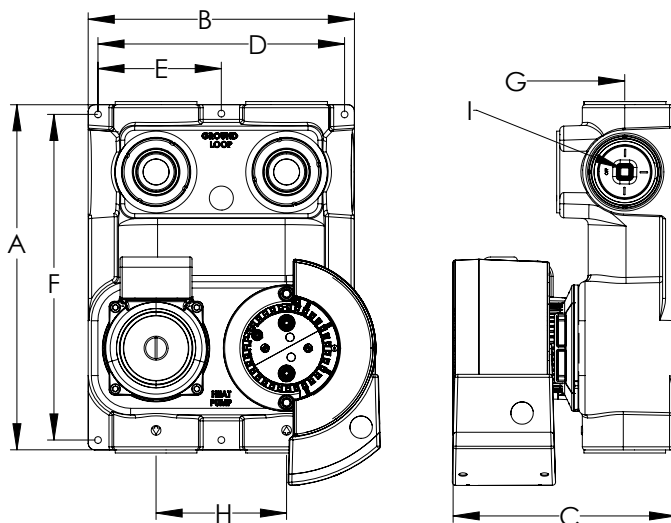



Fluid connections are Flo-Link™ double O-ring style. Transition fittings are not included with the flow center packaging. Typically, PE fusion x Flo-Link is used on the ground loop connections. A Geo-Flo hose kit designed for Flo-Link connections includes transition fittings for heat pump connections.

Flow center may be field modified to a one pump flow center by replacing the constant speed pump with a blank plate kit.



GEO-FLO PRODUCTS CORPORATION
 905 Williams Park Drive
 Bedford, IN 47421
 Phone: 812-275-8513 Fax: 812-275-8523
www.geo-flo.com

Appendix F2: Non-Pressurized Variable Speed Flow Center Submittals

	Submittal Data	
	<i>NP^V</i> non-pressurized flow center, variable speed pump	
	Project Name:	
	Contractor:	
	Engineer:	
	Order Number:	
	Additional Information:	

Technical Data

Circulator:	Grundfos Magna GEO 32-140 (variable speed--requires controller)	Max. fluid temp.: 140°F [60°C]
Cabinet:	Powder coated galvanized steel	Min. fluid temp.: 14°F [-10°C]
Tank:	Polyvinyl chloride (PVC)	Max. operating press.: 13 psig [89.6 kPa]
Insulation:	CFC-free polyurethane foam	Max. ambient air temp.: 104°F [40°C]
Valves:	1", 3-way, 4-position flushing and isolation/service valve, composite valve body and spool, NBR seals, stainless steel retaining ring	Max. ambient relative humidity: 80%

Electrical and Power Data

Motor: 208-230V, 50/60 Hz, single phase, 2-pole, ETL_{C/US} approved (meets UL and CSA requirements), electronically protected, insulation class F, 0.09 to 1.7 Amps (at 230V)

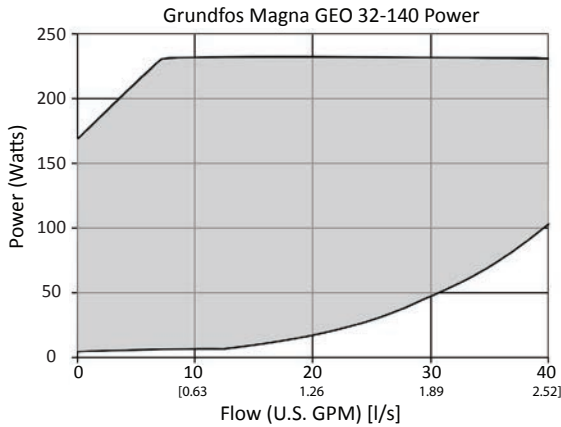

NOTES: The Magna GEO (variable speed) pump adjusts speed (when used with controller) to maintain flow rate or temperature difference. For Watts based upon a specific flow rate and pressure drop, go to www.geo-flo.com, and use the pump sizing calculator.

Approved Antifreeze

Propylene Glycol
Methanol
Ethanol

Mounting

Flow center is designed for indoor installation only.

Flow center must be installed in an upright position as shown to the right.



The pump terminal box should be located in one of the following orientations:

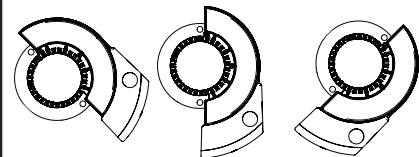

Pump Performance Curves

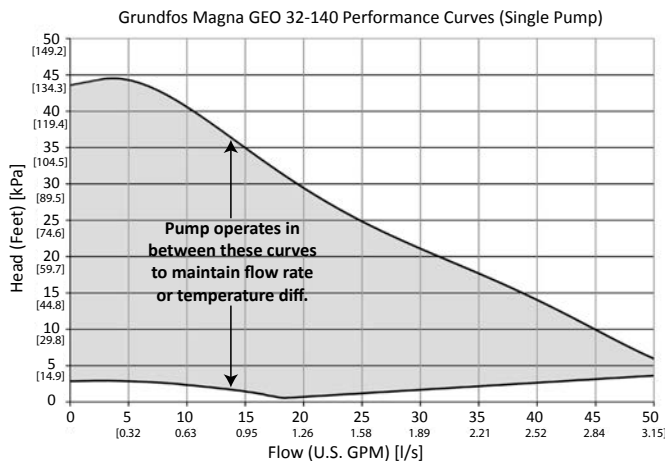

Curves are manufacturer's reported averages using water at 68°F [20°C].



GEO-FLO PRODUCTS CORPORATION
905 Williams Park Drive
Bedford, IN 47421 U.S.A.
PH: 812-275-8513; FAX: 812-275-8523
www.geo-flo.com

Appendix F2: Non-Pressurized Variable Speed Flow Center Submittals

Dimensional Data

	A	B	C	D	E	F	G	H	I	J*	WEIGHT	
Inches	30-1/2	9	11-1/8	16	32	4	9-3/8	24-1/8	4-1/2	3/8" DRIVE SOCKET	LBS	KG
CM	77.4	22.8	28.3	40.7	81.1	10.2	23.9	61.4	11.4		51.0	23.1

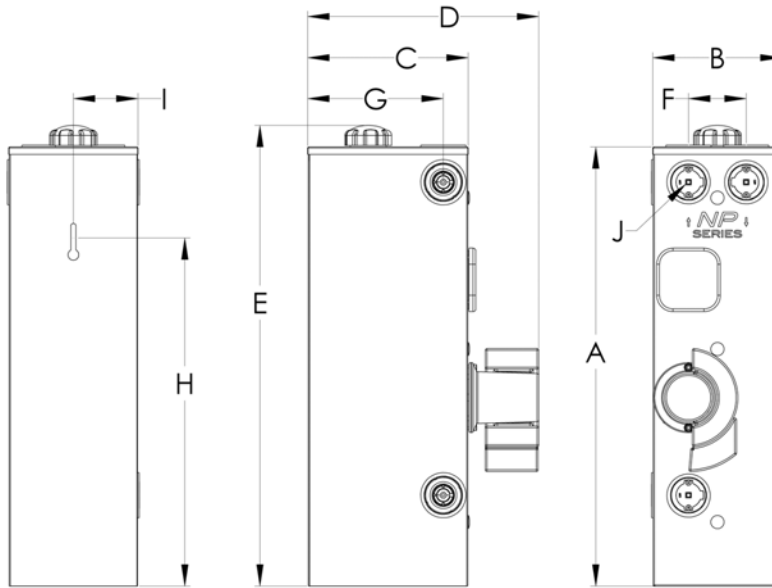

*Requires two Flo-Link™ (double O-ring) transition fittings. Typically, PE fusion or PVC glue fittings are used for the ground loop; a hose kit or PVC glue fitting is used for the heat pump connection.

Flow center may be upgraded to a two pump flow center by removing the blank plate, and adding a second constant speed pump (UPS26-99).



GEO-FLO PRODUCTS CORPORATION

905 Williams Park Drive



Bedford, IN 47421 U.S.A.

PH: 812-275-8513; FAX: 812-275-8523

www.geo-flo.com

SD 1275 rev. 02JAN2013

Appendix F2: Non-Pressurized Variable Speed Flow Center Submittals

	Submittal Data <i>NP</i> ^{V2} non-pressurized flow center, variable speed, double pump
	Project Name:
	Contractor:
	Engineer:
	Order Number:
	Additional Information:

Technical Data	
Circulators: Grundfos UPS26-99 & Magna GEO variable speed (requires controller) Cabinet: Powder coated galvanized steel Tank: Polyvinyl chloride (PVC) Insulation: CFC-free polyurethane foam Valves: 1", 3-way, 4-position flushing and isolation/service valve, composite valve body and spool, NBR seals, stainless steel retaining ring	Max. fluid temp.: 140°F [60°C] Min. fluid temp.: 20°F [-7°C] Max. operating press.: 13 psig [89.6 kPa] Max. ambient air temp.: 104°F [40°C] Max. ambient relative humidity: 80%

Electrical Data							
UPS26-99 motor: 230V, 60 Hz, single phase, 2-pole, UL and CSA approved, internal thermal over-load protection, insulation class F, three speed Magna GEO motor: 208-230V, 50/60 Hz, single phase, 2-pole, ETL _{C/US} approved (meets UL and CSA requirements), electronically protected, insulation class F, variable speed							
Pump Motor	Speed	Nominal HP	Volts	Amps*	Watts*	Capacitor	Pump Housing (Volute)
UPS26-99	High	1/6	230	0.9	196	5µF/400V	Cast Iron
	Medium			0.8	179		
	Low			0.7	150		
Magna GEO	Variable	1/6	208-230	0.09 to 1.7	5 to 230	N/A	Cast Iron

*At 230V

Approved Antifreeze Propylene Glycol Methanol Ethanol

Mounting

Flow center is designed for indoor installation only.

Flow center must be installed in an upright position as shown to the right.



The pump terminal box should be located in one of the following orientations:

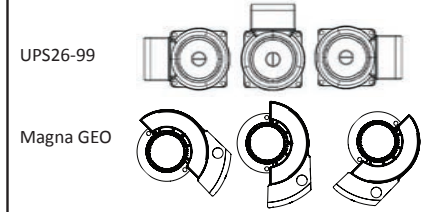

Pump Performance Curves

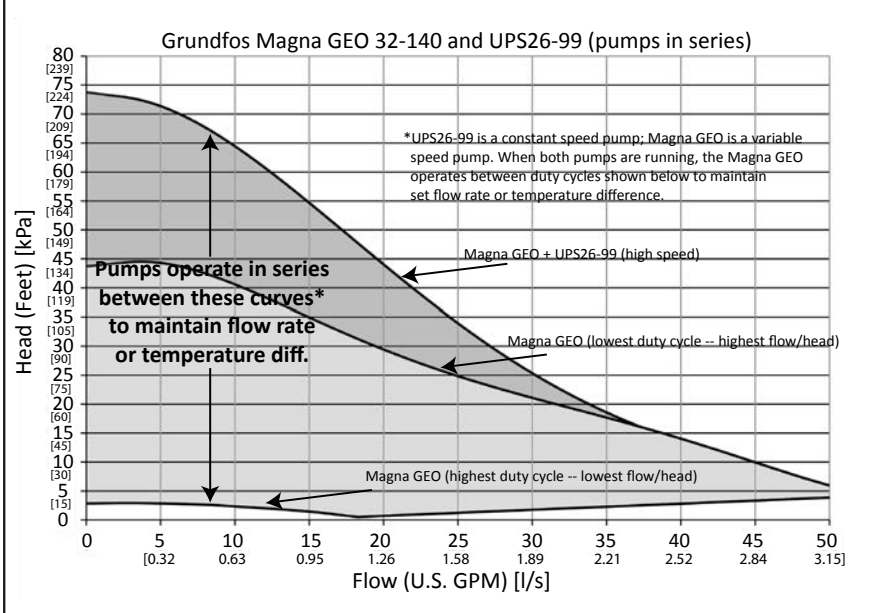

Curves are manufacturer's reported averages using water at 68°F [20°C].



GEO-FLO PRODUCTS CORPORATION
 905 Williams Park Drive
 Bedford, IN 47421 U.S.A.
 PH: 812-275-8513; FAX: 812-275-8523
 www.geo-flo.com

Appendix F2: Non-Pressurized Variable Speed Flow Center Submittals

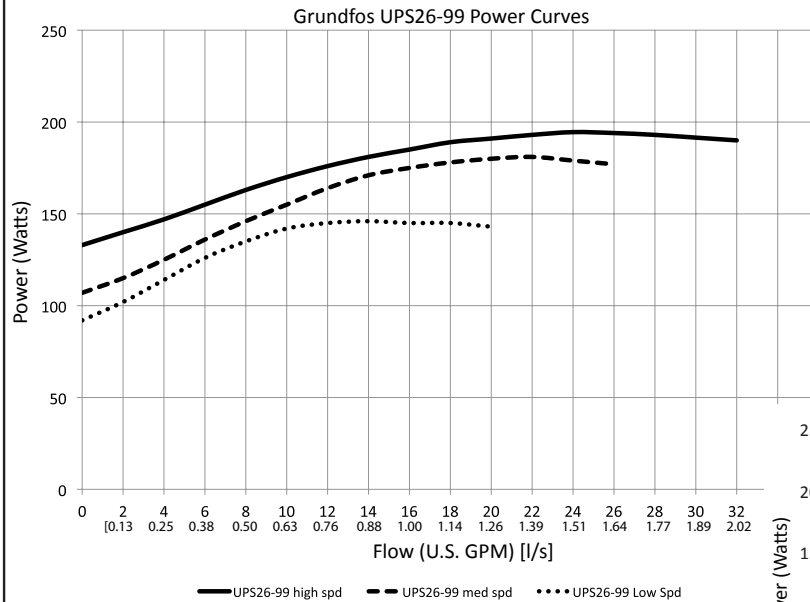
Pump Power Curves

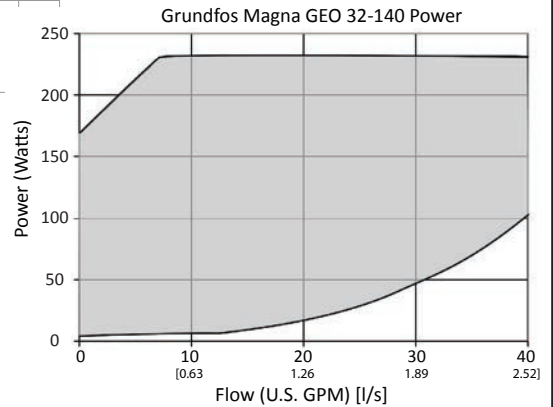

NOTES: The Magna GEO (variable speed) pump adjusts speed (when used with controller) to maintain flow rate or temperature difference. The controller energizes the constant speed pump (UPS26-99) when the Magna GEO cannot meet setpoint, and adjusts the Magna GEO pump accordingly. Total flow center Watts equals constant speed pump Watts plus Magna GEO Watts at design conditions. For Watts based upon a specific flow rate and pressure drop, go to www.geo-flo.com, and use the pump sizing calculator.



Dimensional Data

	A	B	C	D	E	F	G	H	I	J*	WEIGHT	
Inches	30-1/2	9	11-1/8	16	32	4	9-3/8	24-1/8	4-1/2	3/8" DRIVE SOCKET	LBS	KG
CM	77.4	22.8	28.3	40.7	81.1	10.2	23.9	61.4	11.4		56.0	25.4

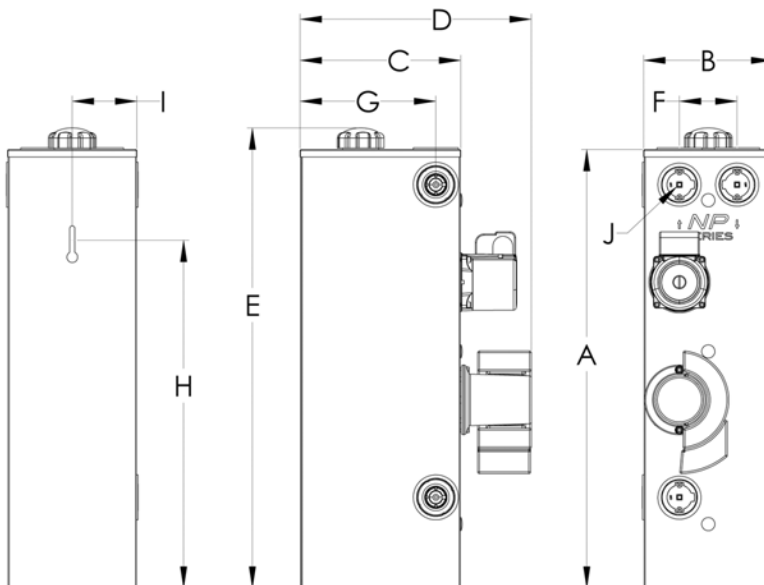

*Requires two Flo-Link™ (double O-ring) transition fittings. Typically, PE fusion or PVC glue fittings are used for the ground loop; a hose kit or PVC glue fitting is used for the heat pump connection.

Flow center may be field modified to a one pump flow center by replacing the upper constant speed pump with a blank plate.



GEO-FLO PRODUCTS CORPORATION

905 Williams Park Drive

Bedford, IN 47421 U.S.A.

PH: 812-275-8513; FAX: 812-275-8523

www.geo-flo.com

SD 1276 rev. 02JAN2013

Appendix G: Antifreeze Fluid Factors

The UPC-GEO controller calculates Heat of Extraction (HE) and Heat of Rejection (HR) based upon the Media Configuration menu (Figure 14). The Media Configuration page allows setting the type and percentage of antifreeze used in the ground loop system. The type choices are ethanol, methanol, glycol, and none. The Media inputs only affect the HE/HR calculation. HE/HR is calculated as follows:

HE or HR = $\Delta T \times \text{Flow Rate (U.S. GPM)} \times \text{Fluid Factor}$

where: ΔT = temperature difference between EWT and LWT

Fluid factor = adjustment for antifreeze

It is possible that the calculation shown on the controller screen is different than a hand calculation. The reason that the calculation could be different is the use of fluid factor. The UPC-GEO calculation is based upon the weight of the fluid, specific heat, percentage of antifreeze, and fluid temperature. Some calculations in the geothermal heat pump industry use a fluid factor of 500 for water, and a fluid factor for all antifreezes of 485. While this will make the calculation easier, and allow the technician to be “in the ballpark”, it may not match the controller display, which uses calculations specific to the current conditions.

Manual Updates Table

Date	Description of Changes	Pages
28OCT2015	Updated Figure 3 for panel mount/NPV kit wiring	8
	Updated Figure 21 drawing	20
	Changed Appendices C through F to D through G	22 - 32
	Added Appendix C (thermistor temperature/resistance chart)	21
23JUL2014	Added note about zone valve requirement for 2 unit applications.	8
	Added zone valves for clarification of application to Figures 4a & 4b.	9
04JUN2014	Added 0-10 VDC output option to General Description and Technical Specifications (added in software version 3.0).	1,2
	Updated Note A in figure 2a to include reference to Figures 2c & 2d.	5
	Added notes to Figure 2c.	6
	Added wiring diagram for heat pumps with only 230 VAC accessory output terminals (Figure 2d).	7
	Added caution about incorrect variable speed pump HV wiring.	
	Added installation tip about panel mount flow centers.	
	Added wiring/piping diagrams for one flow center & two heat pumps	8
	Added wiring diagrams for 0-10 VDC output	10
	Updated figures, setup menu descriptions and operation for new 3.0 software.	11 - 15
	Added formula for HE/HR.	14
	Updated external relay recommendations based upon the latest Grundfos communications.	Appendix C
	Added new appendix for information on HE/HR calculations	Appendix F
17MAR2014	Reformatted manual to match other product IOMs.	All
	Replaced UP26-99 with UPS26-99 (pump upgrade).	Various
	Added additional information to Note 1 about the need for an additional isolation relay for some heat pump controls.	5,6
	Added two new wiring diagrams for heat pump controls without accessory relay isolation and for heat pumps without accessory relay connection.	6
	Added unlock sequence for Lockout mode	10
	Added screen color to troubleshooting chart	11
	Removed kit # 3696 (Flow Only -- no longer offered); added isolation relays to pictures, kit part lists; added kit # 3766 (Flow & Temperature, PVC connections).	14
	Updated verbiage for hi in-rush current conditions	Appendix C
	Updated pressurized variable speed submittals to latest version. Added NP series non-pressurized variable speed flow center	Appendix E
25OCT2012	Modified wiring diagram (added isolation relay; added note on wiring second pump; updates notes 1 and 2)	6
	Added isolation relay to 3696 controller kit picture and content list	15
	Added isolation relay to 3698 controller kit picture and content list	16
11JUL2012	First published	All



Installation, Operating, and Maintenance Manual
Grundfos Universal Pump Controller: UPC-GEO

www.geo-flo.com

Members of ...



Geo-Flo Products Corporation
905 Williams Park Drive
Bedford, Indiana 47421, U.S.A.

Main Number: 812-275-8513
Toll Free: 800-784-8069
Fax: 888-477-8829

Geo-Flo Products Corporation is continually working to improve its products. As a result, the design and specifications of products in this catalog may change without notice and may not be as described herein. For the most up-to-date information, please visit our website, or contact our customer service department at jmoan@geo-flo.com. Statements and other information contained in this document are not express warranties and do not form the basis of any bargain between the parties, but are merely Geo-Flo's opinion or commendation of its products.