



www.geo-flo.com

Geothermal and
Hydronics Specialists

Installation, Operating, and Maintenance Manual



Part # 3866
Rev. 11NOV2013

NP Series Dual Circuit Non-Pressurized Flow Centers

Table of Contents

General Description	1
Flow Center Sizing	2
Installation	5
Flushing and Purging	6
Start-up12
Maintenance.14
Troubleshooting18
Appendix A: Submittal Data19

NOTES:

This guide provides the installer with instructions specific to NP Series Dual Circuit Flow Centers. Please refer to your heat pump manufacturer’s instructions or IGSHPA guidelines for additional detailed flushing, purging, and installation information. Please review the entire IOM document before proceeding with the installation.

Geo-Flo Products Corporation is continually working to improve its products. As a result, the design and specifications of products in this catalog may change without notice and may not be as described herein. Statements and other information contained in this document are not express warranties and do not form the basis of any bargain between the parties, but are merely Geo-Flo’s opinion or commendation of its products.

General Description

The NP Series Dual Circuit is a family of non-pressurized flow centers used for closed-loop geothermal (ground source) heat pump systems, and is specifically designed for applications with two geothermal heat pumps sharing a common ground loop. The NP Series flow centers use a water column to provide the necessary suction head for the circulator pumps, and to ensure a flooded pump volute. Each NP Series Dual Circuit (NPD) flow center consists of a fluid reservoir (tank), six flush and service valves, and two, three or four pumps housed in a foam-insulated powder coated cabinet. Built-in check valves in each of the two fluid paths prevent short-circuiting between the two heat pumps. The flow center includes a sealing cap to ensure a closed system while providing integrated pressure and vacuum relief to prevent the reservoir from being over-pressurized or dropping below atmospheric pressure. The NPD is manufactured with single speed or three speed pumps to provide a variety of options to the contractor and system designer. Figure 1 shows the fluid flow to and from the NPD flow center.

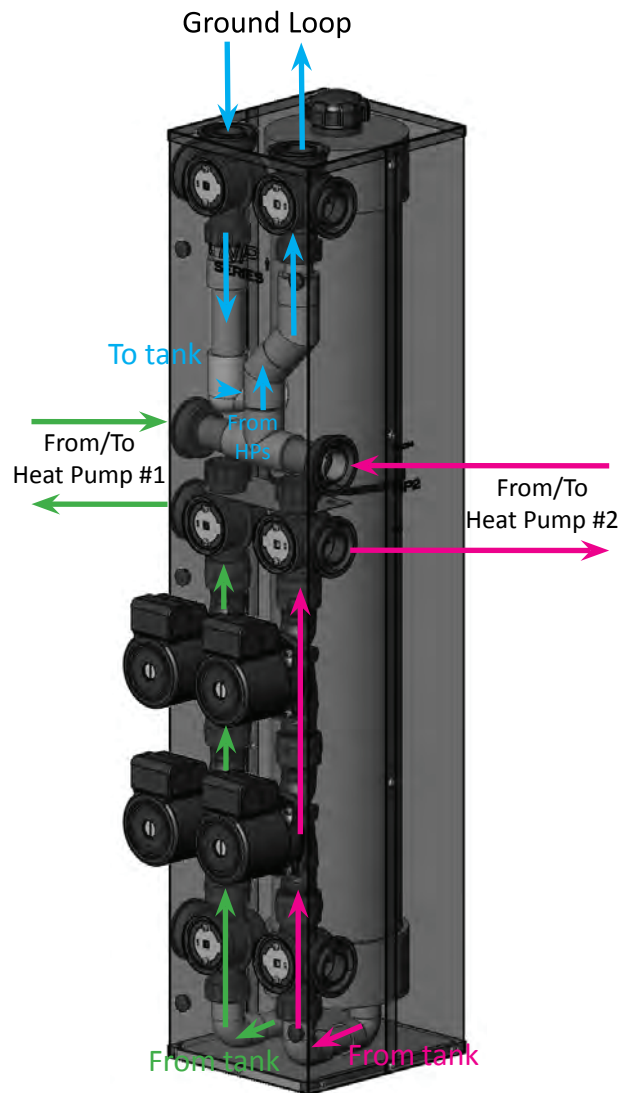

Figure 1: Generalized fluid flow (components inside cabinet)

Flow Center Sizing

Design Notes

The dual circuit flow center includes a pump(s) for each heat pump. The pump(s) for unit A is in parallel with the pump(s) for unit B. If one side has two pumps (e.g. NDP³ or NDP⁴), the two pumps on each side are in series. Figure 1 shows a transparent view of the flow center with internal piping.

When sizing pumps for a dual circuit flow center, a pressure drop calculation should be done for the entire system when both heat pumps are running. Pump selection must be based upon both units running. For example, if the left side is a 3 ton heat pump with one pump, and the right side is a 2 ton heat pump with one pump; the pumps in parallel must be able to provide adequate flow and head when both units are running. Verify with online Calculators at www.geo-flo.com, or to manually select pumps, use the curves below, which include parallel operation.

The internal check valves and 3-way valves must be added to the system pressure drop before selecting pumps. Table 1 includes a chart based upon the flow rate for each heat pump.

Performance Curves - NPD²

The NPD² flow center uses one UPS26-99 or one UP26-116 on each side. The curves below illustrate performance of these two pumps operating in parallel. Use the curves to determine pump selection when both heat pumps are operating. Two pumps in parallel provide twice the flow rate, but the head of only one pump. Internal check valves are factory-installed to prevent short-circuiting.

Grundfos Pump Performance Curves: UPS26-99, UP26-116
(NPD²: one pump on LH side; one pump on RH side -- two pumps in parallel)

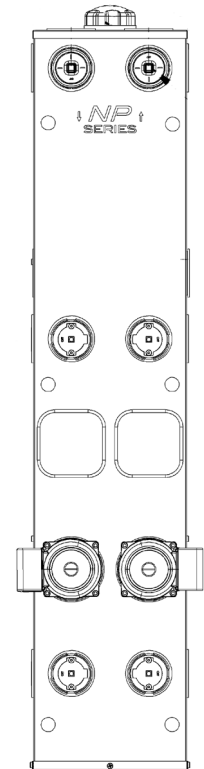
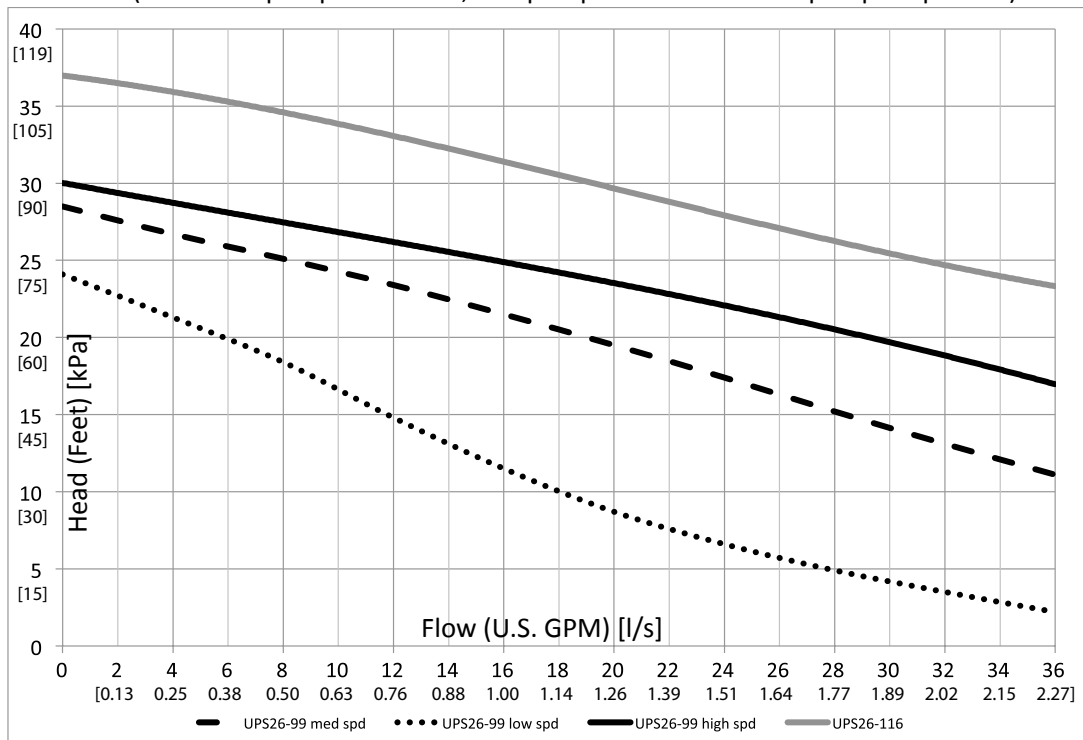

NPD²

All pump curves are manufacturer's reported averages using water at 68°F [20°C]

Performance Curves - NPD³

The NPD³ flow center uses two UPS26-99 or two UP26-116 pumps on side A and one UPS26-99 or one UPS26-116 pump on side B. The curves below illustrate performance of these two sets of pumps operating in parallel. Use the curves to determine pump selection when both heat pumps are operating. Two pumps in parallel with one pump creates a curve that is the sum of the two curves (gray line). Internal check valves are factory-installed to prevent short-circuiting.

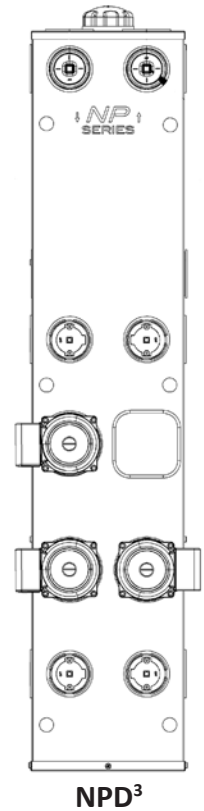
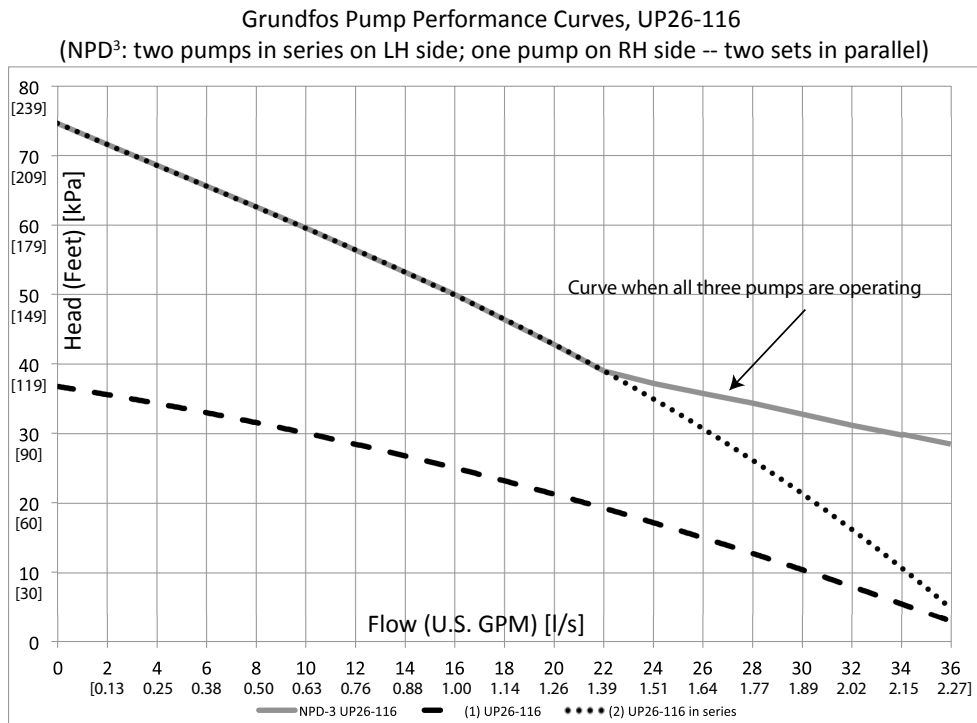
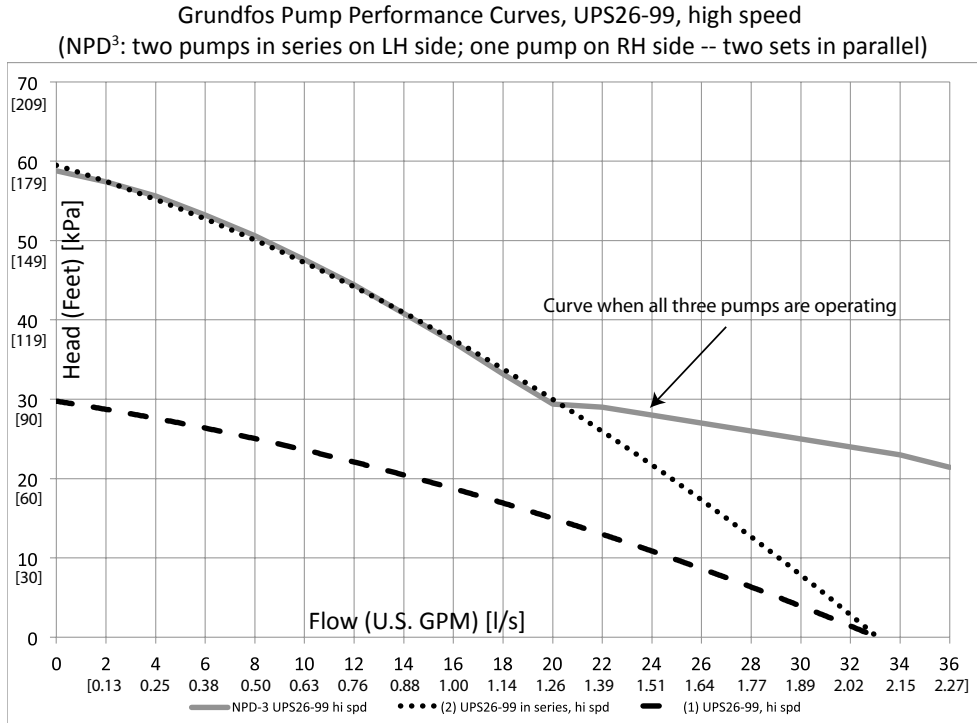

All pump curves are manufacturer's reported averages using water at 68°F [20°C]

Performance Curves - NPD⁴

The NPD⁴ flow center uses two UPS26-99 pumps in series or two UP26-116 pumps in series on each side. The curves below illustrate performance of these two sets of pumps operating in parallel. Use these curves to determine pump selection when both heat pumps are operating. Two pumps in series with two pumps in parallel provide twice the flow rate and twice the head of one pump. Internal check valves are factory-installed to prevent short-circuiting.

Grundfos Pump Performance Curves: UPS26-99, UP26-116

(NPD⁴: two pumps in series on LH side; two pumps in series on RH side -- two sets in parallel)

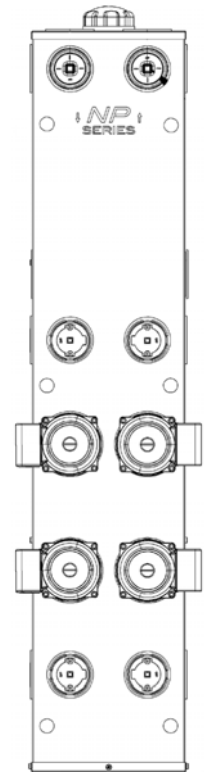
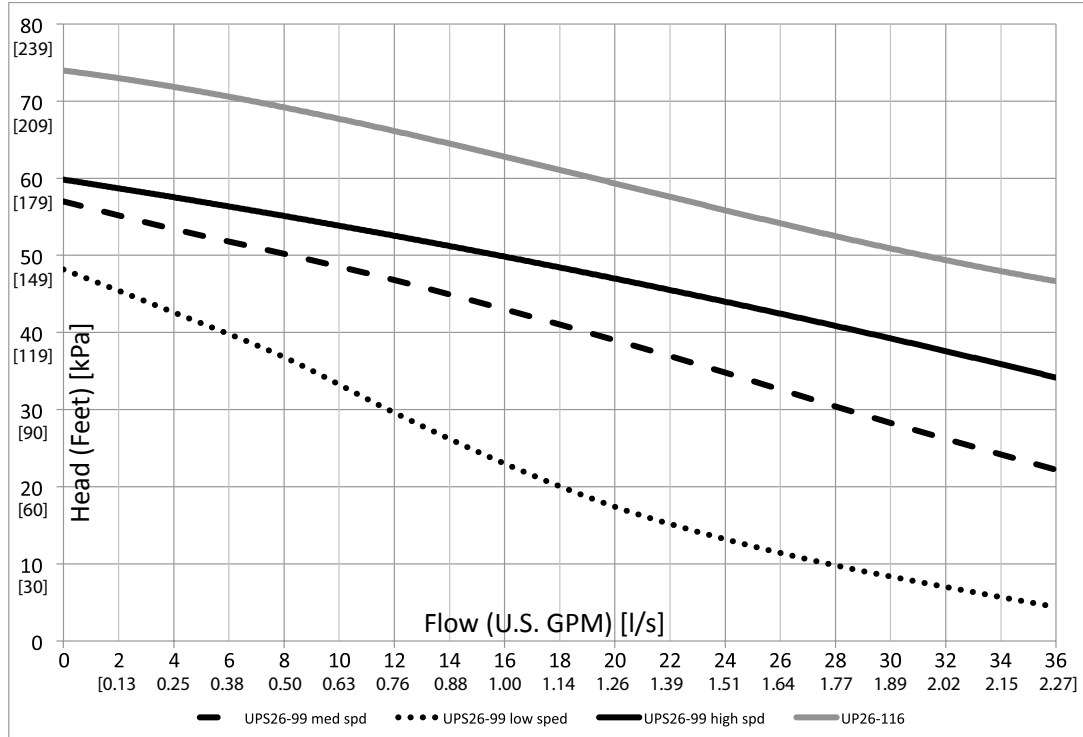

Check Valves and 3-way Valves Pressure Drop

Table 1 provides pressure drop addition for use in calculating system pressure drop. Use the table to account for pressure drop of internal components in the dual circuit flow center.

Pressure Drop Addition for Internal Check Valves and 3-Way Valves			
Flow Rate (GPM)			Tot. Press. Drop (ft. hd.)*
Side A	Side B	Total	
6	6	12	2.3
	9	15	3.1
	12	18	4.2
	15	21	5.6
9	6	15	3.1
	9	18	4.1
	12	21	5.3
	15	24	6.8
12	6	18	4.2
	9	21	5.3
	12	24	6.7
	15	27	8.3
15	6	21	5.6
	9	24	6.8
	12	27	8.3
	15	30	10.1

Table 1: Pressure Drop Addition

*Includes internal check valves and 3-way valves.

Installation

Mounting the unit

The NP Series Dual Circuit flow center must be mounted on a level surface near the ground source heat pumps. If desired, the unit can be placed on the floor or on an isolation pad such as a small piece of expanded polystyrene (blue board insulation). The unit should be secured using the supplied shipping/mounting brackets. Figure 2 shows various locations where the brackets can be attached to the unit. Self-tapping sheet metal screws and lag screws are provided to allow the installer options on installation.

Plumbing Options

The NPD flow center can be plumbed with a wide variety of materials including HDPE, PVC, copper, PEX, and flexible hose to provide many options to the installer. The flow directions to and from the flow center are shown in Figure 1. The installer can choose to plumb the ground loop piping to the top or sides of the flow center depending on how the loop piping is installed. The flow direction is chosen by turning each of the 3-way valves with a 3/8" square drive on a ratchet wrench so that the fluid is directed in the desired way. Figures 3 and 4 show examples of piping configurations utilizing HDPE and flexible hose transitions. The piping should be properly supported to prevent excessive stress on the three-way valves.

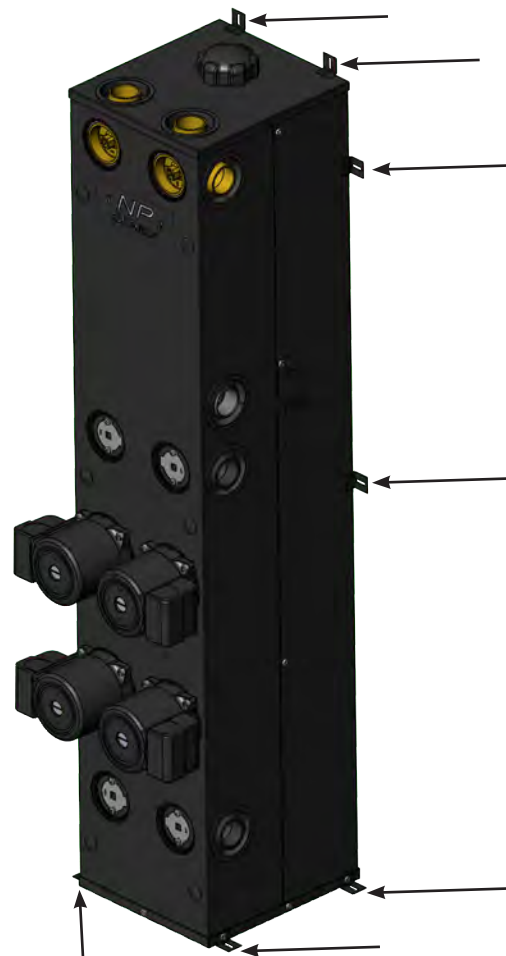

Figure 2: Mounting brackets (arrows indicate locations)

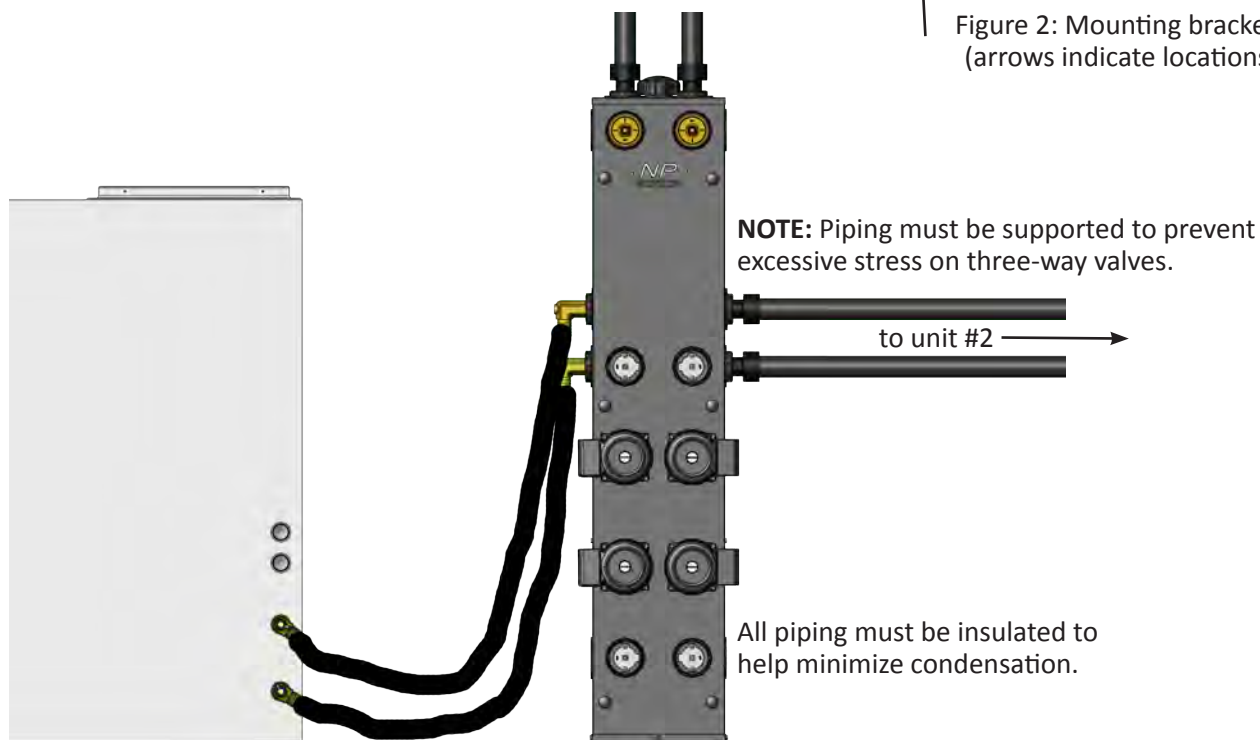

Figure 3: Example piping with hose kit to unit #1 and HDPE to unit #2

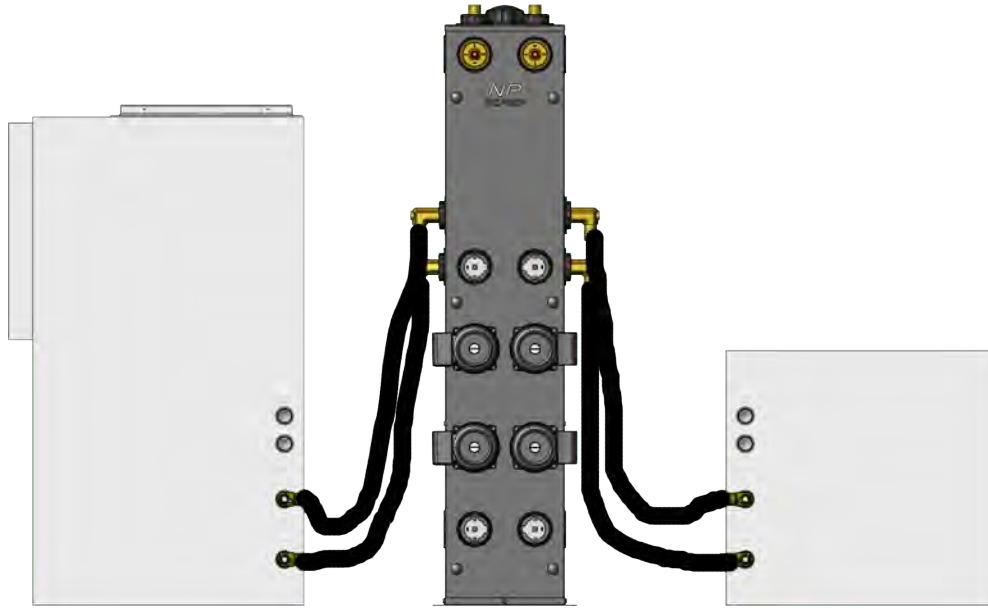

Figure 4: Example piping with hose kits to both heat pumps

Flushing and Purging

NOTICE: Using a quality flush cart is the fastest and easiest way to ensure that all air and debris is removed from the ground loop. The flush cart must be able to provide a minimum fluid velocity of 2 ft/s through all piping, provide filtering, and allow power flushing. It is extremely common for construction debris, polyethylene pipe shavings, dirt, sand, rocks, etc. to enter the ground loop piping during installation. The wet rotor circulator pump(s) used during system operation require clean, debris-free fluid to function properly. A small amount of debris in the ground loop could become lodged between the pump's rotor and stator housing causing pump failure a few days to a few years after initial installation. This preventable issue is a common mode of failure for circulators. Although the NP Series flow centers do have the ability to separate air from the loop fluid, its pumps are not powerful enough to guarantee that all air and debris can be flushed from every type of loop during the initial loop installation. Geo-Flo recommends flushing all ground loops with a quality flush cart to ensure that the loop is free of air and debris when the loop installation contractor leaves the job site.

Flushing with Flush Cart



CAUTION: NEVER DEAD-HEAD THE FLUSH CART PUMP INTO THE FLUID RESERVOIR OF THE NPD. NEVER ATTEMPT TO FLUSH THROUGH THE TANK USING A FLUSH CART PUMP. OVER-PRESSURIZATION OF THE FLUID RESERVOIR COULD BE DANGEROUS AND WILL VOID THE WARRANTY.

1. Rotate supply and return ground loop valves to bypass the tank. OFF should be in the 6 o'clock position on both upper valves (Figure 5).
2. Remove the cap from the NP Series tank. This step is precautionary and intended to protect the flow center from accidental over-pressurization. If the operator places the valves in the incorrect orientation and starts the flush cart, the fluid from the flush cart will quickly fill and overflow the tank.

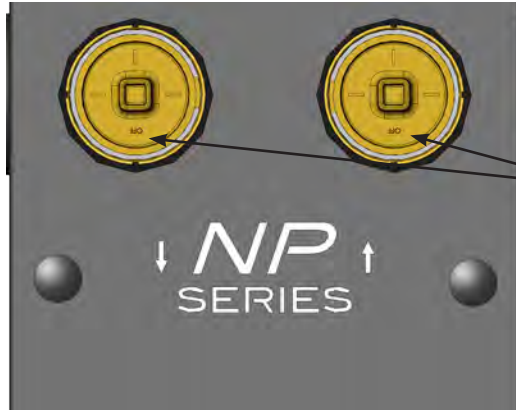

Figure 5: Valve positions for flushing with the flush cart

OFF is in 6 o'clock position

3. Attach the flush cart to the 3-way valves using Flo-Link double O-ring X 1" CAM fittings (Figure 6). The flush cart pump discharge hose should be connected to the upper left valve and the return hose should be connected to the upper right valve. Apply a small amount of lubrication to the O-rings to allow the fittings to be installed and removed with little force (see note below). The plastic nuts should be hand-tightened only.

NOTE: The NBR (nitrile) O-rings used in Geo-Flo valves and on Flo-Link double O-ring fittings are not sensitive to petroleum jelly or silicone based lubricants. However, other types of natural and synthetic rubber can react to petroleum and/or silicone based lubricants. For example, silicone based lubricant should not be used with silicone O-rings or seals. There is no single lubricant than is a perfect solution for every need. Therefore, care should be taken when selecting a lubricant for a particular application.

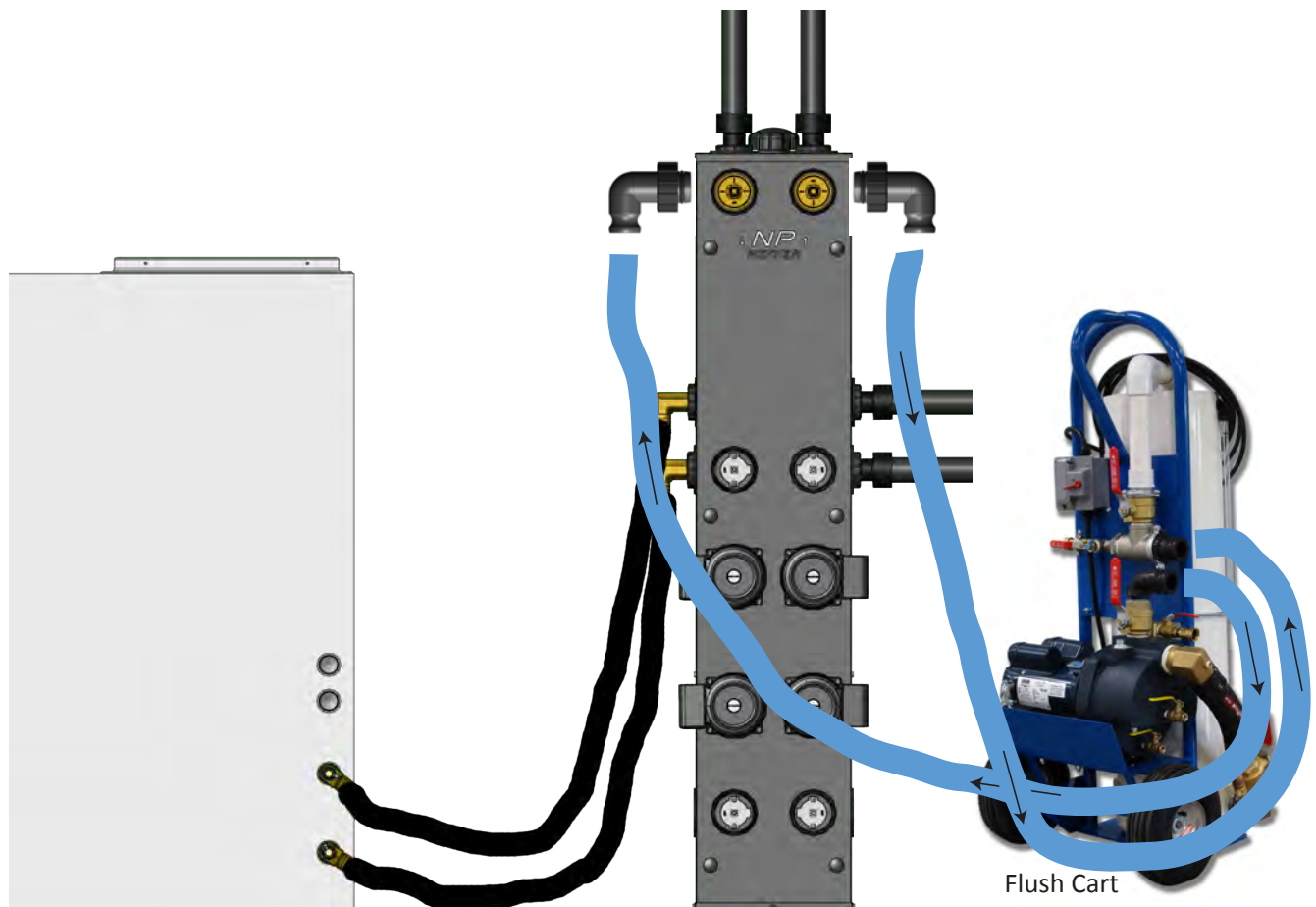

Figure 6: Connecting flush cart to NPD flow center

- Flush/purge the ground loop using a high quality flush cart per the flush cart manufacturer's instructions. Geo-Flo provides detailed instructions on operating the flush cart manufactured by Geo-Flo.

NOTE: Fluid should not enter the NP Series tank during flushing. If it does, immediately stop the flush cart pump and check to be sure the valves are in the correct orientation as shown in Figure 5.



WARNING: ONLY USE PREMIXED ANTIFREEZE IN A NON-FLAMMABLE STATE. FAILURE TO OBSERVE SAFETY PRE-CAUTIONS MAY RESULT IN FIRE, INJURY, OR DEATH.

- Add antifreeze as required to the ground loop.
- Turn off flush cart. **DO NOT PRESSURIZE LOOP.**
- Rotate the upper valves to isolate the ground loop. OFF will be in the 12 o'clock position if the loop is plumbed to the top ports (Figure 7).
- Fill the NP Series flow center reservoir with clean, debris free loop fluid. This can be the same pre-mixed fluid that remains in the flush cart after flushing and filling the loop. The tank should be filled to above the return pipe and below the upper valve. Figure 8 shows a cross section of the NPD flow center, indicating the approximate fluid level. The tank will be topped off after all flushing is complete. Filling can be accomplished by pouring the fluid into the top of the tank, or by attaching a hose to the lower left valve and turning the valve's OFF position to 12 o'clock (Figure 9). Introduce the fluid to the tank slowly while monitoring the fluid level to prevent over-filling the tank. The tank will hold approximately 5 gallons of fluid. When complete, rotate the valve's OFF position back to the 6 o'clock position and remove the hose.

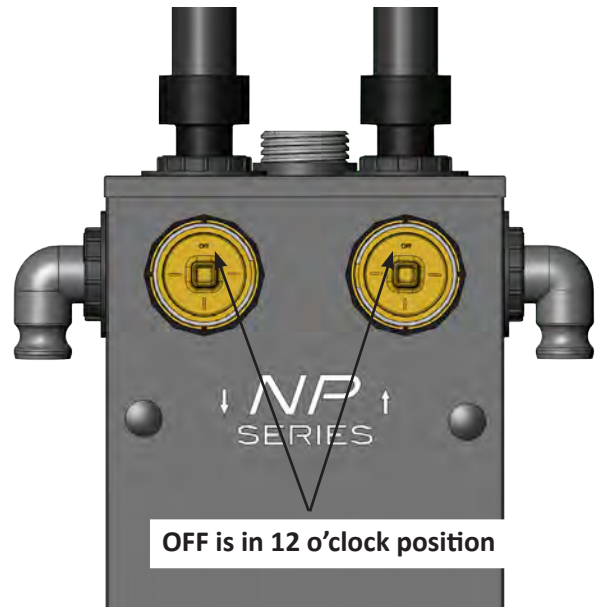

Figure 7: Valve position to isolate loop

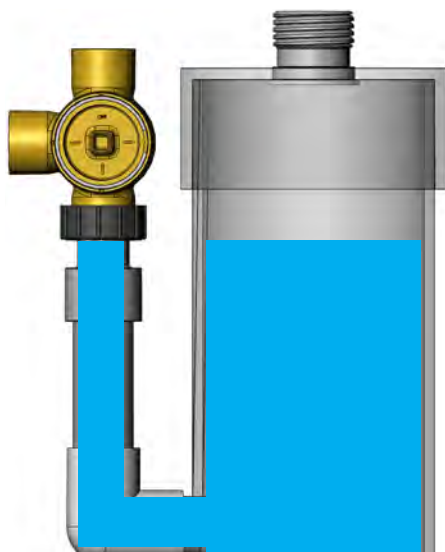

Figure 8: Initial fluid level of the NPD tank (blue shading)

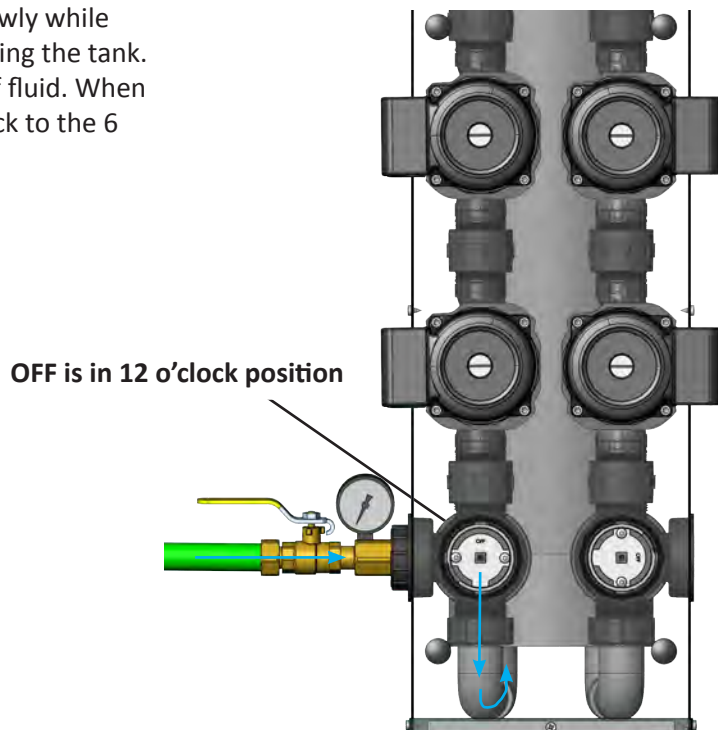

Figure 9: Filling tank
(blue arrows show path into tank)

Flushing Heat Pump #1

1. Remove the flush cart discharge hose from the upper left valve and install it in the lower left valve. The flush cart return hose remains in the upper right valve.
2. Rotate OFF on the lower left valve to the 6 o'clock position to isolate the tank. Rotate OFF on the middle left valve to the 12 o'clock position to open flow to heat pump #1. Be sure the upper valves are rotated to isolate the ground loop (OFF in 12 o'clock position if ground loop is plumbed to top ports). See Figure 10.
3. Flush/purge heat pump #1 using a high quality flush cart per the flush cart manufacturer's instructions. Geo-Flo provides detailed instructions on operating the flush cart manufactured by Geo-Flo.
4. Rotate the lower left valve so that OFF is in the 9 o'clock position. Remove the flush cart discharge hose from the lower left valve and install a plug seal and cap (Figure 11). Be sure to lubricate the O-rings on the plug seal to allow for easier removal during future service.

NOTE: Pull the flush fittings directly out of the valve ports. Do not rock the fittings up and down or side to side or you may crack the valve port and void the warranty.

Flushing Heat Pump #2

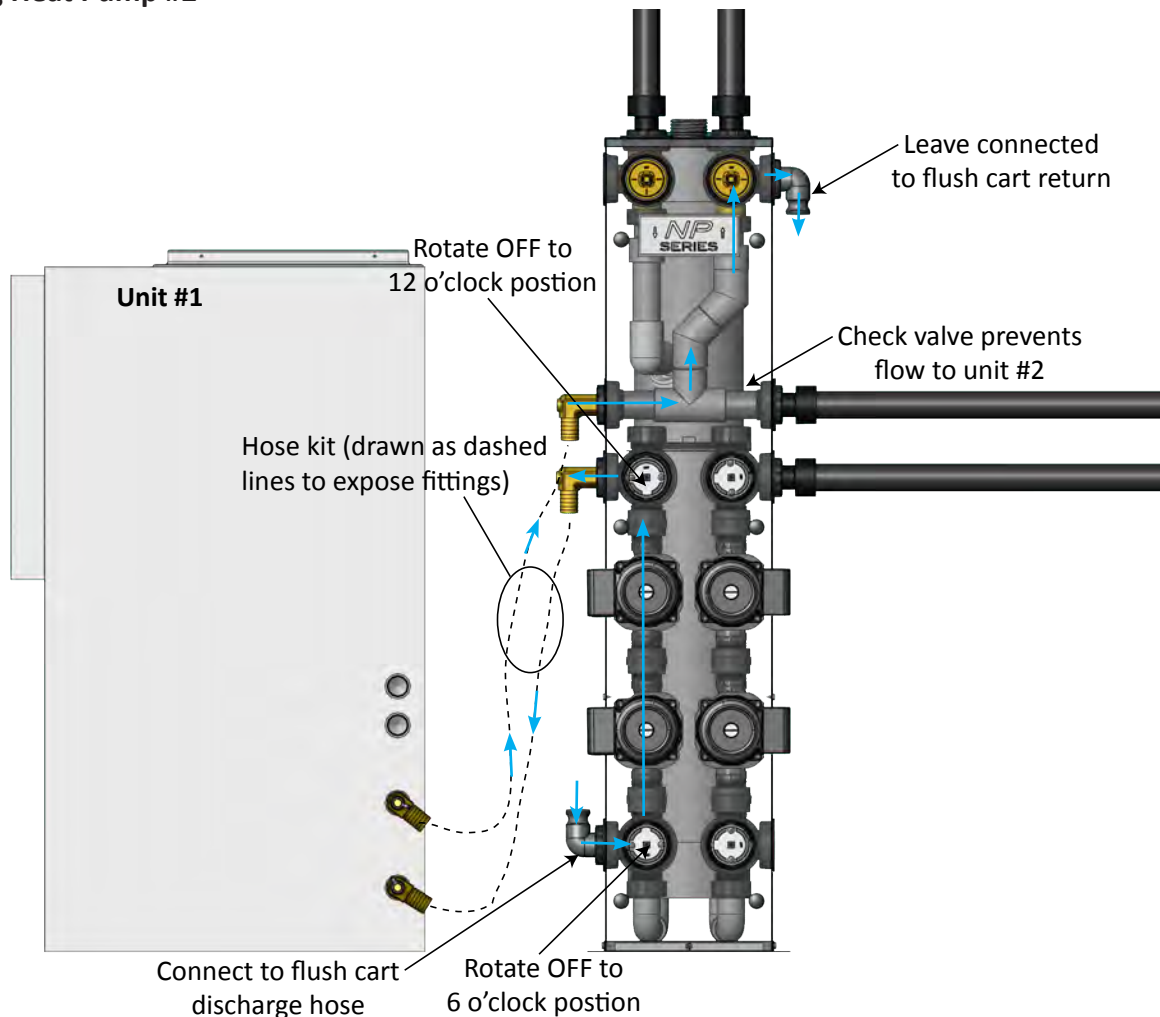

Figure 10: Flushing Heat Pump #1
(blue arrows show flushing path)

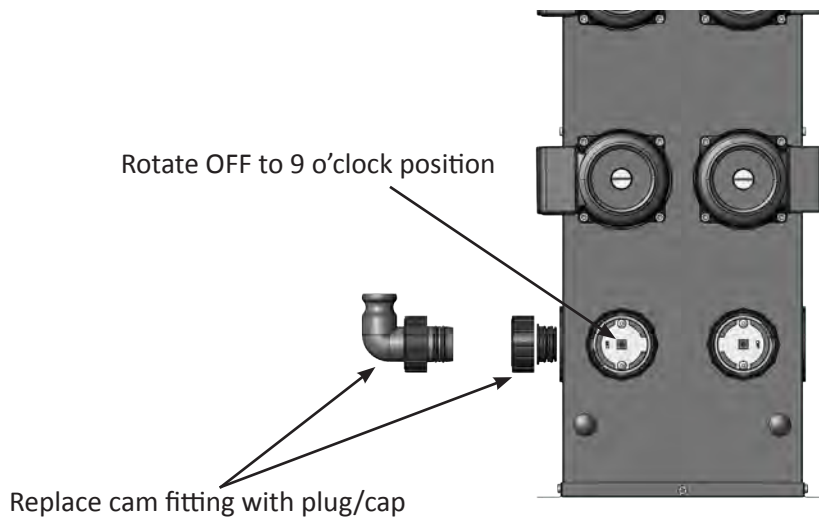

Figure 11: Completing unit #1 flushing; preparing to flush unit #2

1. Install the flush cart discharge hose in the lower right valve. The flush cart return hose remains in the upper right valve with OFF on this valve in the 12 o'clock position.
2. Rotate OFF on the lower right valve to the 6 o'clock position to isolate the tank. Rotate OFF on the middle right valve to the 12 o'clock position to open flow to heat pump #2. (Figure 12).
3. Flush/purge heat pump #2 using a high quality flush cart per the flush cart manufacturer's instructions.

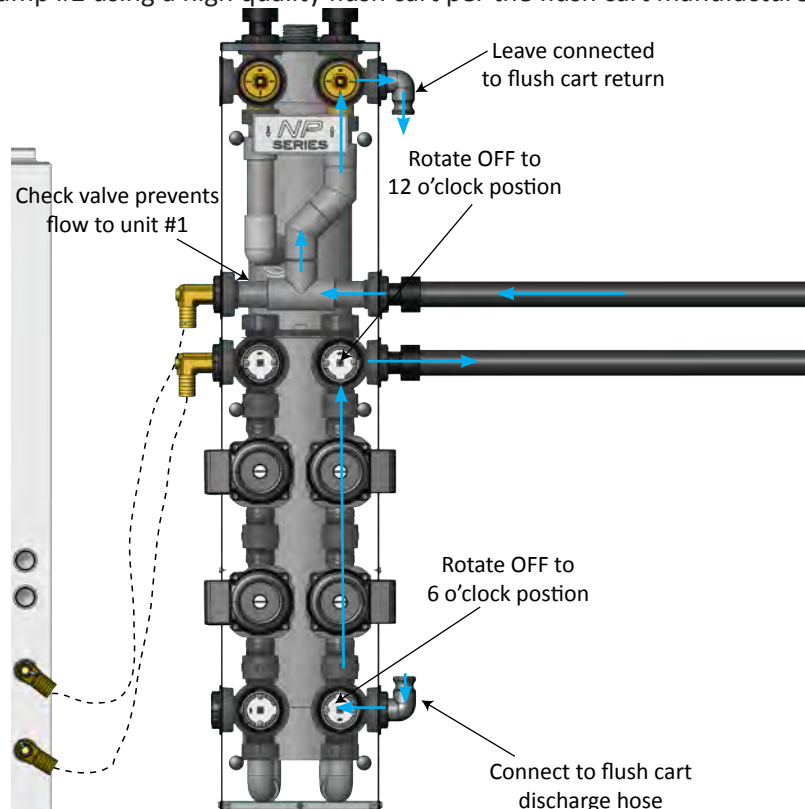

Figure 12: Flushing Heat Pump #2 (blue arrows show flushing path)

Geo-Flo provides detailed instructions on operating the flush cart manufactured by Geo-Flo.

4. Rotate the lower right valve so that OFF is in the 3 o'clock position. Remove the flush cart discharge hose from the lower left valve and install a plug seal and cap (Figure 13). Be sure to lubricate the O-rings on the plug seal to allow for easier removal during future service.

NOTE: Pull the flush fittings directly out of the valve ports. Do not rock the fittings up and down or side to side or you may crack the valve port and void the warranty.

5. Rotate OFF on the upper right valve to the 3 o'clock position. Remove the flush cart return hose and

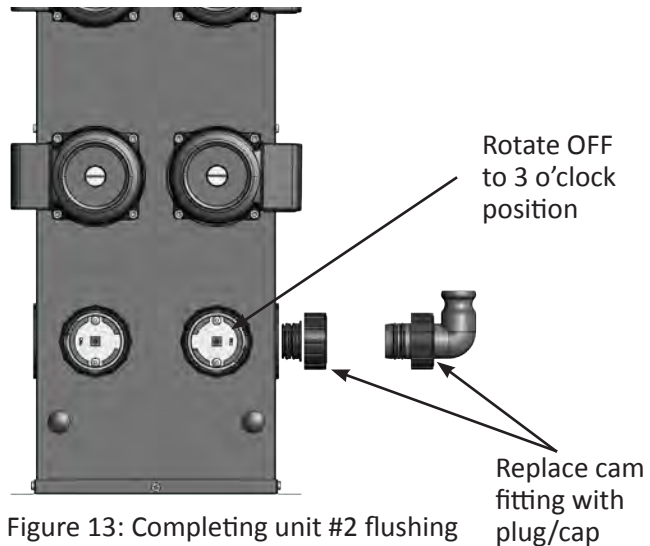

Figure 13: Completing unit #2 flushing

install a plug seal and cap. Install a plug seal and cap to the upper right valve (Figure 14).

6. Fill the NP Series flow center reservoir with clean, debris free loop fluid. Pour the fluid into the top until the level reaches 1-2" below the bottom of the neck (Figure 15).
7. Replace the tank's cap tightening until you hear a "click" similar to an automotive gas cap. Rotate OFF on the upper left valve to the 9 o'clock position (Figure 16).
8. Proceed to Start Up section of IOM (next page).

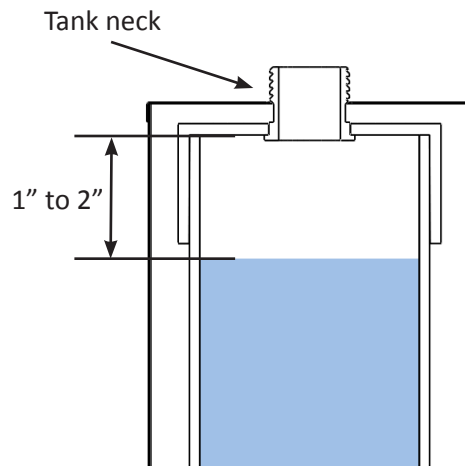

Figure 15: Fill level

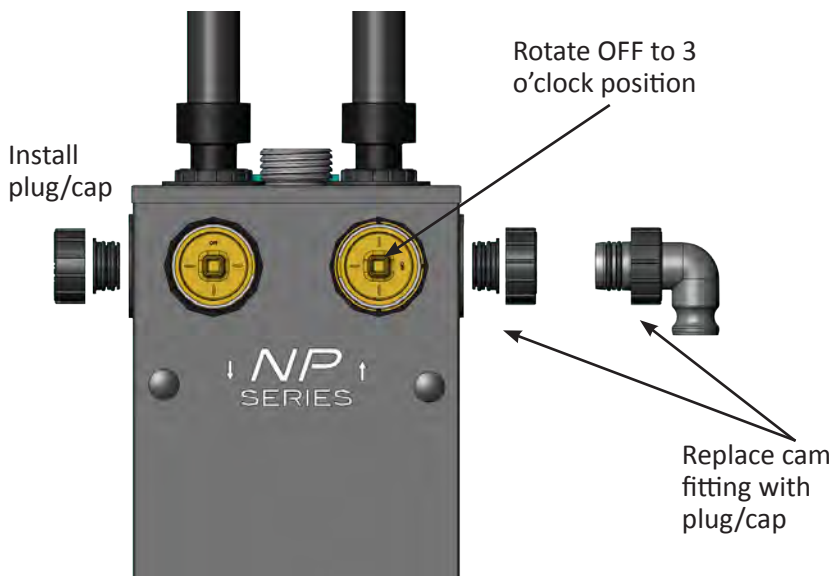

Figure 14: Completing unit #2 flushing

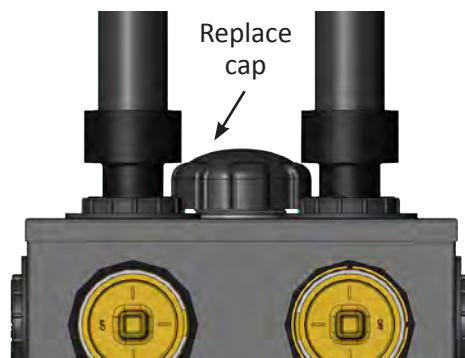

Figure 16: Replace top cap

Start-Up



WARNING: OPEN THE MAIN POWER SUPPLY DISCONNECT SWITCH AND SECURE IT IN AN OPEN POSITION PRIOR TO PERFORMING ELECTRICAL WORK. VERIFY THAT POWER HAS BEEN DISCONNECTED PRIOR TO WIRING THE PUMP(S). FAILING TO SECURE THE ELECTRICAL SUPPLY COULD RESULT IN SERIOUS INJURY OR DEATH.

Preparing Flow Center for Start-Up

1. Wire the circulator pumps to the heat pumps as shown in Figure 17. Follow all electrical and local codes for wiring and fuse/breaker sizing.

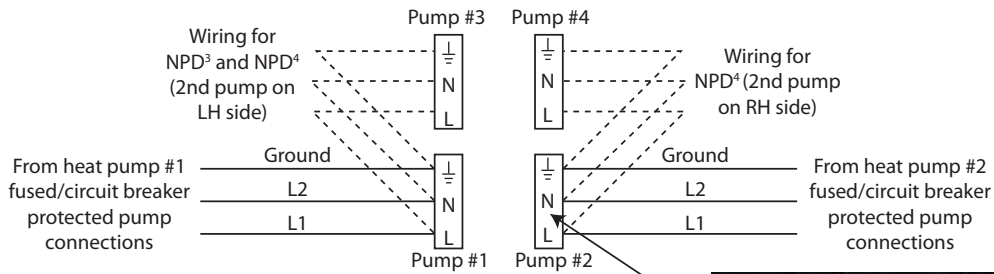

Figure 17: Pump field wiring

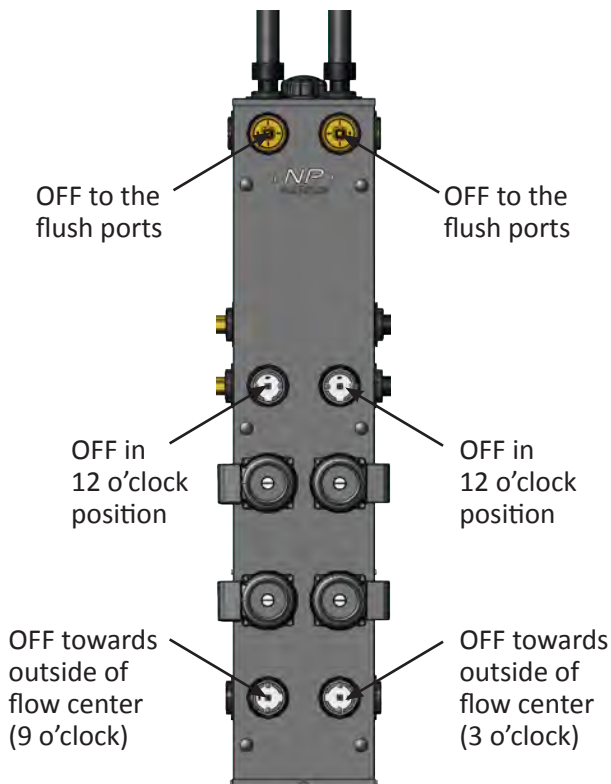
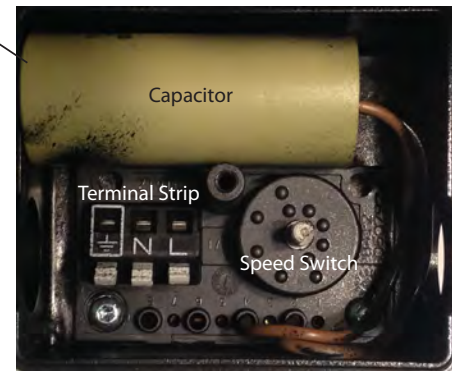

Figure 18: Final valve positions

2. Rotate NP Series flow center valves to the correct operating positions (Figure 18). OFF on the lower two valves will be toward the outside of the flow center. OFF for the middle two valves will be in the 12 o'clock position. OFF for the upper valves will be toward the flush ports, and can be either the top or side ports depending on how the ground loop is plumbed.
3. Open the vent screw in the center of each pump motor with a large flat head screwdriver allowing a few drops of fluid to drip out. Then, retighten the vent screw.

NOTE: Step #3 is critical. Opening the vent screw and allowing fluid to drip out ensures that all trapped air has exited the pump motor. Skipping this important step could lead to premature pump failure.

4. Start all flow center pumps and allow system to operate for several minutes. Remove tank's cap and check fluid level, adding additional loop fluid if necessary, while pumps are running. Fluid should be about 2" below the bottom of the tank's neck as shown in Figure 15. Replace the cap and tighten until there is an audible "click" similar to an automobile's gas cap.
5. Measure and record the flow rate using one of the methods described in the following section of this document. The flow rate through each heat pump must be verified with both heat pumps operating simultaneously. If using a NPD-99, with three speed pumps, the flow can be adjusted by changing the pump(s) speed. The flow rate should be within the range suggested by the heat pump manufacturer.
6. Verify the performance of the heat pumps per the manufacturer's literature by calculating the heat of extraction and/or rejection (HE-HR). The Geo-Flo website has a free calculator to assist in this calculation. Go to www.geo-flo.com, select Design Calculators then HE-HR Calculator. The HE-HR should be within the range specified by the heat pump manufacturer.
7. Install all valve face covers (Figure 19).

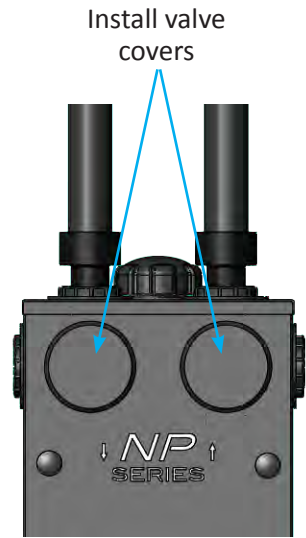

Figure 19: Valve covers

Measuring System Flow Rate -- Method 1: Flow Rate from Pressure Drop

The system flow rate can be determined using two different methods as described below.

1. Measure the pressure drop across the heat pump's heat exchanger via the P/T ports located at the water connections of the unit (Figure 20). Use a single large dial face pressure gauge to allow for more precise measurement.
2. Determine the flow rate using the manufacturer's published tables for pressure drop versus flow (Table 2). If the pressure drop is off the manufacturer's chart, the flow rate can be determined using a free online calculator available on Geo-Flo's website. Go to www.geo-flo.com, select Design Calculators then Flow Rate Calculator.

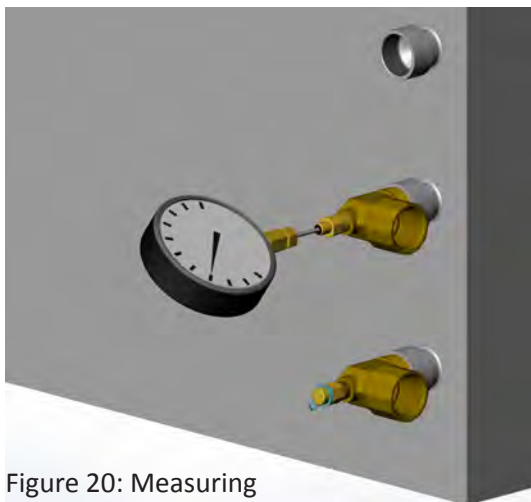

Figure 20: Measuring pressure drop

EWT °F	Flow gpm	WPD	
		PSI	FT
20	3.0	0.9	2.2
	4.5	1.8	4.2
	6.0	2.9	6.8
30	3.0	0.9	2.1
	4.5	1.7	4.0
	6.0	2.8	6.6
40	3.0	0.9	2.0
	4.5	1.7	3.9
	6.0	2.8	6.4
50	3.0	0.9	2.0
	4.5	1.6	3.8
	6.0	2.7	6.2

Table 2: Example of heat pump manufacturer's table of pressure drop vs. flow rate

Measuring System Flow Rate --

Method 2: Direct measurement using a Geo-Meter

1. Attach the Geo-Meter to the upper left valve using a Flo-Link double O-ring x 1" CAM fitting and direct the flexible hose into the top of the tank.
2. Energize the pump(s).
3. Rotate valve #2 so that OFF is in the 6 o'clock position. This directs the fluid through the Geo-Meter. Be sure the Geo-Meter is vertical. (Figure 21).
4. Read the flow rate.

NOTE: The Geo-Meter's flow range is 2-20 GPM. Therefore it is likely that this direct measurement method can only be utilized for a single heat pump at a time.

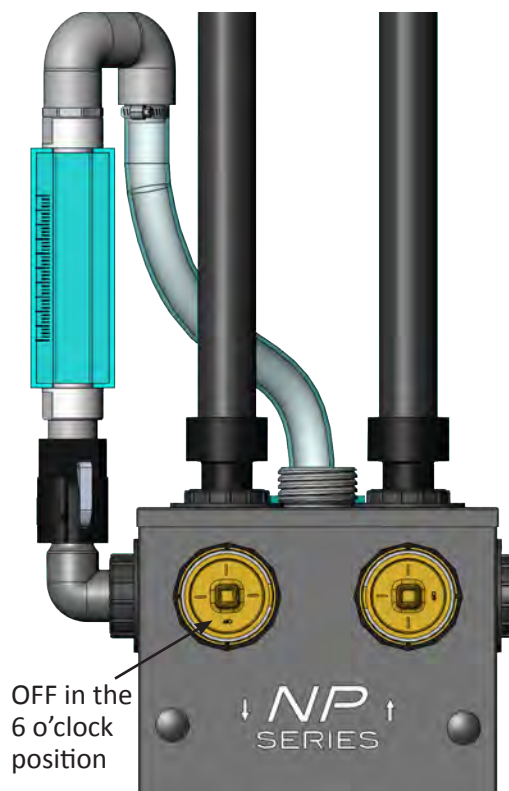

Figure 21: Using Geo-Meter

Maintenance

There is no regularly scheduled maintenance required for the NP Series flow center. However, the fluid level in the tank should be monitored particularly during the first several days after installation or service has been performed.

Replacing circulator pump



WARNING: OPEN THE MAIN POWER SUPPLY DISCONNECT SWITCH AND SECURE IT IN AN OPEN POSITION PRIOR TO PERFORMING ELECTRICAL WORK. VERIFY THAT POWER HAS BEEN DISCONNECTED PRIOR TO WIRING THE PUMP(S). FAILING TO SECURE THE ELECTRICAL SUPPLY COULD RESULT IN SERIOUS INJURY OR DEATH.

1. Determine whether the circulator pump needs to be replaced. The pump motor should only be replaced after successfully troubleshooting the system and determining that the pump is not functioning. See Troubleshooting section of this document for more information.
2. Install a hose from the upper right valve and direct it into the top of the tank using a Flo-Link adapter (such as a garden hose adapter or hose barb). Alternatively, the Geo-Meter tool may be used. Rotate OFF on both upper valves to the 12 o'clock position to isolate the ground loop. (Figure 22).
3. Rotate OFF on the middle valve to the 6 o'clock position. The middle left valve is rotated to replace a pump servicing heat pump #1. The middle right valve is rotated to replace a pump servicing heat pump #2.
4. Rotate OFF on the lower valve to the 6 o'clock position to isolate the tank from the pump stack. Remove the cap and plug seal on the lower valve and capture the fluid that exits in a pan. Retain this fluid to add back to the tank after service is complete (Figure 23).

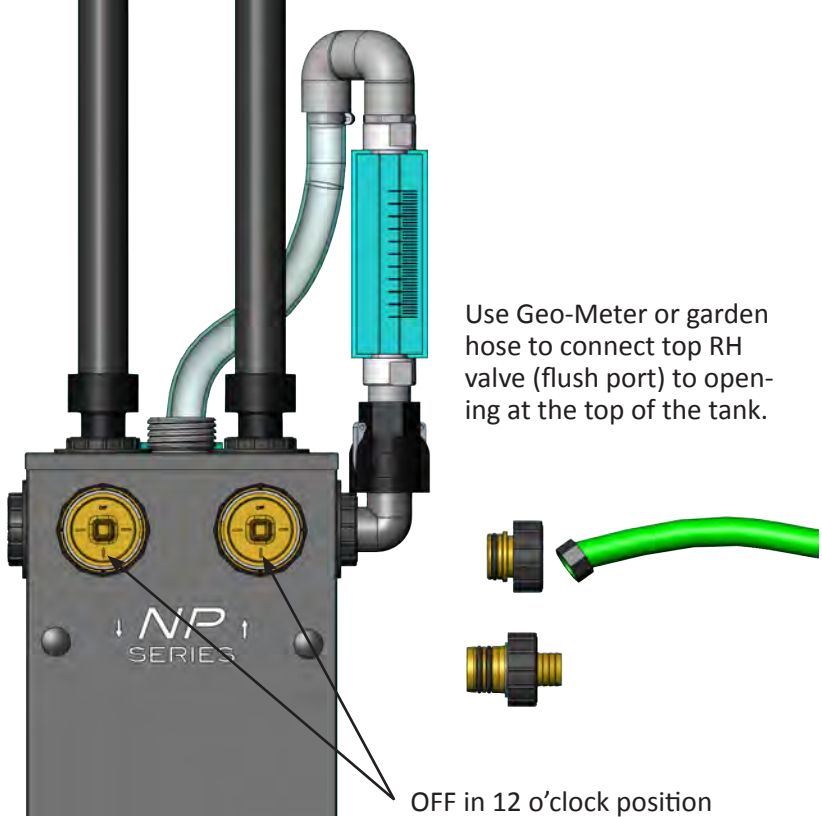

Figure 22: Isolating loop

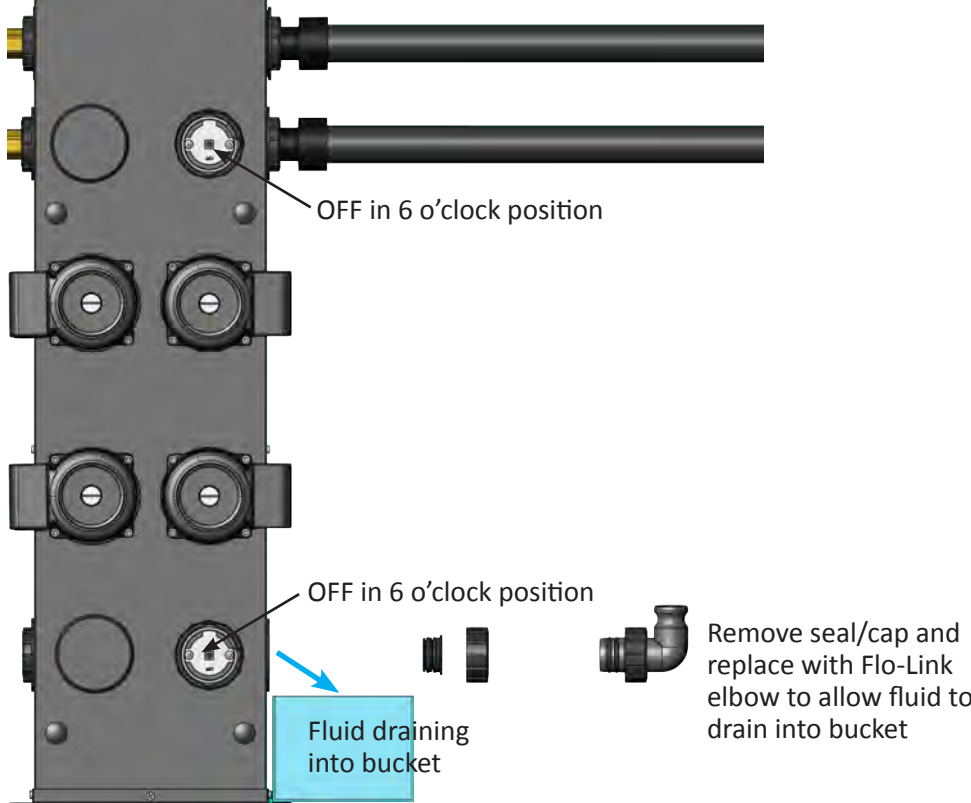

Figure 23: Catching fluid from pump stack when replacing pump motor

5. Verify that power has been disconnected from the circulator pump(s) using a multi-meter.
6. Disconnect wiring from pump.
7. Remove screws holding pump motor to pump housing (volute), and remove the pump motor.
8. Inspect the pump motor and volute for signs that indicate the mode of failure. For example, if debris is present in the pump or volute the ground loop should be re-flushed with a quality flush cart equipped with a filter.
9. Clean the pump seat on the pump housing (volute) with a cloth to remove any debris so that the gasket on the pump will seal properly. Install the new pump motor and reconnect wiring.
10. Replace plug seal and cap. Rotate the bottom and middle valves back to their operating positions (Figure 24).
11. Replace the loop fluid that was removed from the system in Step 4. Fill the tank as needed.
12. Open the vent screw in the center of the pump motor just installed with a large flat head screwdriver allowing a few drops of fluid to drip out. Then, retighten the vent screw.

NOTE: Step #12 is critical. Opening the vent screw and allowing fluid to drip out ensures that all trapped air has exited the pump motor. Skipping this important step could lead to premature pump failure.

13. Energize the pump(s) on the side just replaced (HP #1 or HP #2). Fluid from the tank will circulate through the heat pump and back into the tank via the hose installed in Step 2. (Figure 24)
14. Rotate both upper valves back to operating positions (OFF toward flush ports). Remove hose and replace plug seal.
15. Verify system performance by checking the flow rate and temperature differential, and comparing the values to the heat pump manufacturer's published data. If installing a UPS26-99, be sure to set the pump speed that provides a flow rate within the manufacturer's recommend range.
16. Remove the tank's cap and check the fluid level. Fluid should be about 2" below the bottom of the tank's neck as shown in Figure 15. Replace the cap and tighten until there is an audible "click" similar to an automobile's gas cap.
17. Replace valve face covers as shown in Figure 19.

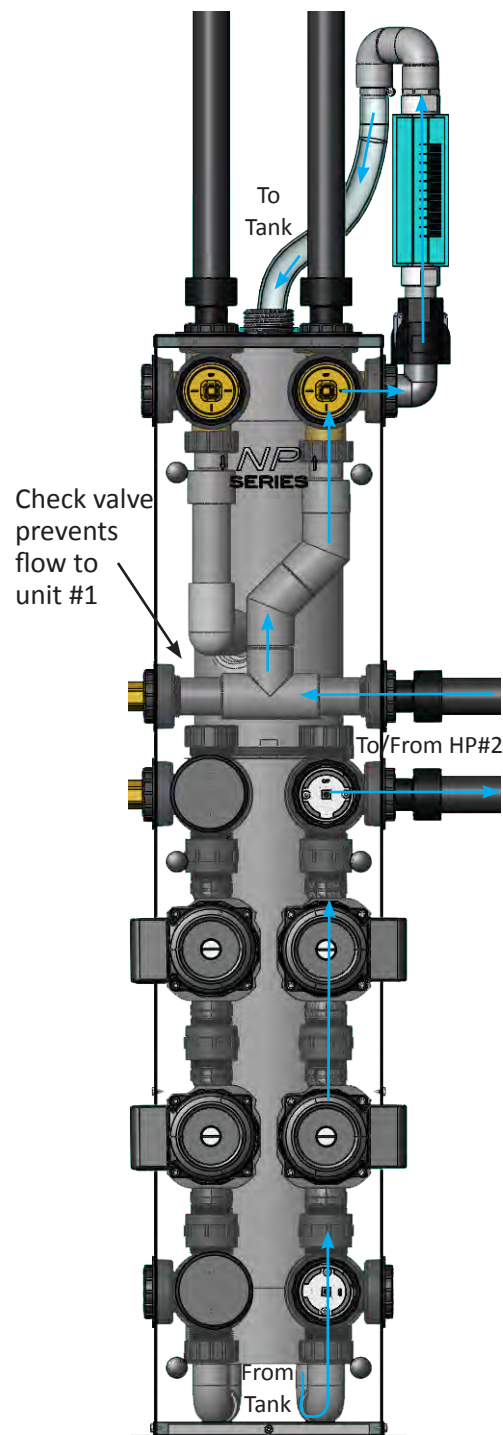

Figure 24: Flushing circuit after changing pump (blue arrows show fluid path)

Converting NPD2 to NPD3/4

Follow procedure for Replacing Circulator Pump except remove the blank plate instead of the pump motor. Be sure to remove the gasket (Figure 25).

Checking anti-freeze/freeze protection level

The loop fluid may contain antifreeze at concentration high enough to achieve a freeze protection level that is generally 10 degrees lower than the lowest expected entering fluid temperature (EWT) to the heat pump. Antifreeze will be used when the loop fluid entering the heat pump (EWT) is expected to drop below 40 degrees F. The freeze protection level depends on the type and concentration of antifreeze.

Loop fluid can be removed from the NP flow center through one of the three way valves, or through the top of the tank. The specific gravity of the fluid can then be measured with an appropriate specific gravity hydrometer. The specific gravity is used to determine the percentage concentration of antifreeze which is then used to determine the freeze protection level. The Residential Pressure Drop calculator available at www.geo-flo.com provides information on percent antifreeze, freeze protection level, and specific gravity for ethanol, methanol, and propylene glycol.

Emptying the tank

Both upper valves should be turned to isolate the NPD flow center from the ground loop and heat pump. The middle valves should be turned to isolate the heat pumps (OFF toward the outside of the flow center). The tank can be emptied by rotating either lower valve so that OFF is toward the inside of the flow center (3 o'clock for the left valve or 9 o'clock for the right valve). A discharge hose can be connected to direct the fluid to a drain or catch basin. Note that the NP Series flow center will hold approximately 5 1/2 gallons of fluid.

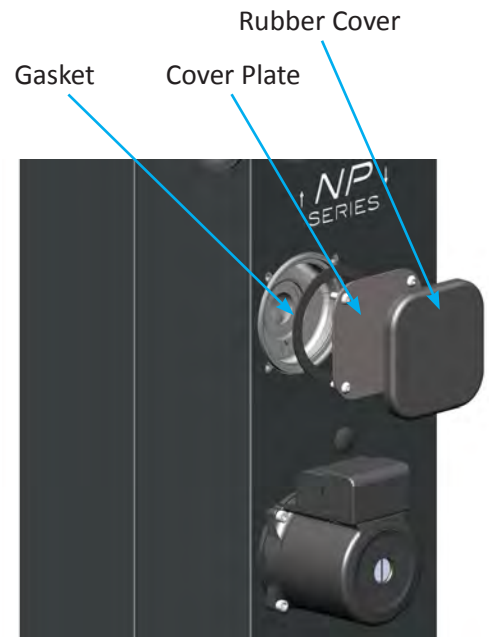

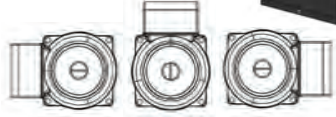
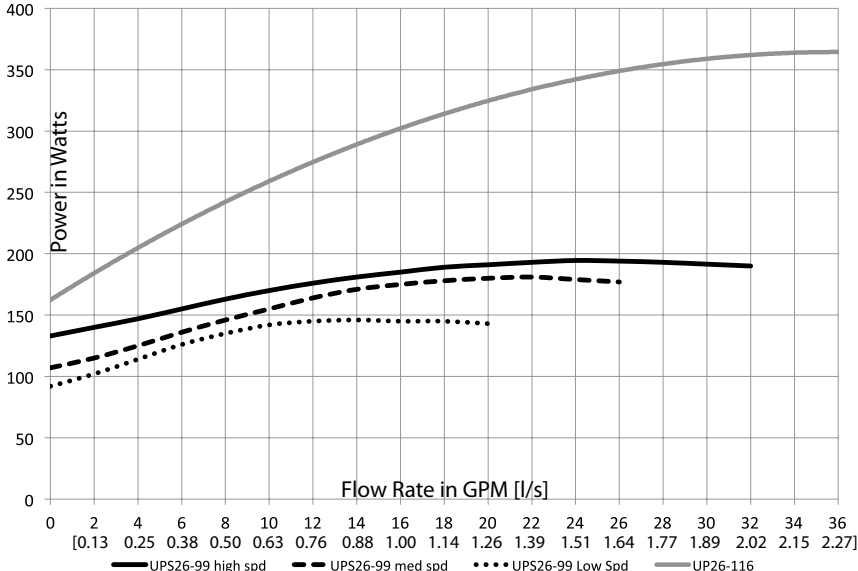



Figure 25: Removing cover plate

Troubleshooting

Problem	Possible Cause	Solution
Water leaks out Cap	Tank over-pressurized	Remove loop fluid
	Cap not sealing	Remove cap; clean reservoir neck and cap gasket; replace cap
		Remove cap; apply lubricant to cap gasket; replace cap
Water leaks out of tank when cap is removed and pump is not energized	Air in loop	Flush system to remove air
	System pressurized	Replace cap quickly; not a problem
Water leaks out valve face	Debris in valve	Rotate valve 360 degrees to dislodge debris
		Remove valve spool; clean valve body and spool; replace O-ring(s) on valve spool if necessary
	Side loading valve spool when rotating with 3/8" drive tool	Rotate valve spool so that no side load is placed on spool
Water drips around O-ring adapter/fittings	Incorrect fitting used (i.e. threaded fitting instead of Flo-Link double O-ring fitting)	Replace incorrect fittings
	Condensation	Insulate piping
	O-ring seal failure	Remove fitting; clean valve port and fittings; replace O-rings if necessary
	Pipe misalignment; side-loading O-rings	Remove fittings; check O-rings and replace if necessary; align piping
Noise in reservoir tank	Air in loop system passing into reservoir	Not a problem. Monitor fluid level; add fluid if necessary
	Low water level in reservoir	Add loop fluid
Low water level in reservoir	Air from loop system deposited into reservoir	Not a problem; add loop fluid
	Pipe expansion	Not a problem; add loop fluid if necessary
	Leak in interior piping	Locate and repair leak
	Leak in ground loop system	Locate and repair leak
No flow to/from tank	Valve(s) in wrong position	Rotate valve(s) to operating position
Air not separating from fluid	Valve(s) in wrong position	Rotate valve(s) to operating position
Pump not operating	No power at pump	Ensure proper power/voltage at pump motor
		Ensure heat pump contacts are operating
		Reset fuse/break in heat pump
	Power at pump but not operating	Remove vent screw and rotate shaft with a small screwdriver. Replace vent screw and re-energize pump.
		Replace pump power head

Appendix A

	<h2 style="margin: 0;">Submittal Data</h2> <p>NP SERIES Dual Circuit Non-pressurized Flow Center</p>																																	
	Project Name:																																	
	Contractor:																																	
	Engineer:																																	
	Order Number:																																	
	Additional Information:																																	
<h2>Technical Data</h2> <table style="width:100%; border: none;"> <tr> <td style="width:50%; border: none;">Circulator: Grundfos UPS26-99 (3 speed) or UP26-116 (single speed)</td> <td style="width:50%; border: none;">Max. fluid temp.: 140°F [60°C]</td> </tr> <tr> <td style="border: none;">Cabinet: Powder coated galvanized steel</td> <td style="border: none;">Min. fluid temp.: 20°F [-7°C]</td> </tr> <tr> <td style="border: none;">Tank: Polyvinyl chloride (PVC)</td> <td style="border: none;">Max. operating press.: 13 psig [89.6 kPa]</td> </tr> <tr> <td style="border: none;">Insulation: CFC-free polyurethane foam</td> <td style="border: none;">Max. ambient air temp.: 104°F [40°C]</td> </tr> <tr> <td colspan="2" style="border: none;">Valves: Quantity six 1", 3-way, 4-position flushing and isolation/service valves. Four bottom valves have composite body and spool; Top valves have brass body and spool. All valves utilize NBR seals and stainless steel retaining ring.</td> </tr> </table>		Circulator: Grundfos UPS26-99 (3 speed) or UP26-116 (single speed)	Max. fluid temp.: 140°F [60°C]	Cabinet: Powder coated galvanized steel	Min. fluid temp.: 20°F [-7°C]	Tank: Polyvinyl chloride (PVC)	Max. operating press.: 13 psig [89.6 kPa]	Insulation: CFC-free polyurethane foam	Max. ambient air temp.: 104°F [40°C]	Valves: Quantity six 1", 3-way, 4-position flushing and isolation/service valves. Four bottom valves have composite body and spool; Top valves have brass body and spool. All valves utilize NBR seals and stainless steel retaining ring.																								
Circulator: Grundfos UPS26-99 (3 speed) or UP26-116 (single speed)	Max. fluid temp.: 140°F [60°C]																																	
Cabinet: Powder coated galvanized steel	Min. fluid temp.: 20°F [-7°C]																																	
Tank: Polyvinyl chloride (PVC)	Max. operating press.: 13 psig [89.6 kPa]																																	
Insulation: CFC-free polyurethane foam	Max. ambient air temp.: 104°F [40°C]																																	
Valves: Quantity six 1", 3-way, 4-position flushing and isolation/service valves. Four bottom valves have composite body and spool; Top valves have brass body and spool. All valves utilize NBR seals and stainless steel retaining ring.																																		
<h2>Electrical Data</h2> <p>Motor: 208-230V, 60 Hz, single phase, 2-pole, UL and CSA approved, internal thermal overload protection, insulation class F</p>	<h2>Approved Antifreeze</h2> <p>Propylene Glycol Methanol Ethanol</p>																																	
<table border="1" style="width:100%; border-collapse: collapse; text-align: center;"> <thead> <tr> <th>Part Number</th> <th>Pump Motor</th> <th>Speed</th> <th>Nominal HP</th> <th>Volts</th> <th>Amps*</th> <th>Watts*</th> <th>Capacitor*</th> <th>Pump Housing (Volute)</th> </tr> </thead> <tbody> <tr> <td rowspan="3">1304,1305,1306</td> <td rowspan="3">UPS26-99</td> <td>High</td> <td rowspan="3">1/6</td> <td rowspan="3">208-230</td> <td>0.9</td> <td>196</td> <td rowspan="3">5µF/400V</td> <td rowspan="3">Cast Iron</td> </tr> <tr> <td>Medium</td> <td>0.8</td> <td>179</td> </tr> <tr> <td>Low</td> <td>0.7</td> <td>150</td> </tr> <tr> <td>1307,1308,1309</td> <td>UP26-116</td> <td>--</td> <td>1/6</td> <td>208-230</td> <td>1.8</td> <td>385</td> <td>2.5µF/380V</td> <td>Cast Iron</td> </tr> </tbody> </table> <p><small>*All data is per pump at 230V.</small></p>	Part Number	Pump Motor	Speed	Nominal HP	Volts	Amps*	Watts*	Capacitor*	Pump Housing (Volute)	1304,1305,1306	UPS26-99	High	1/6	208-230	0.9	196	5µF/400V	Cast Iron	Medium	0.8	179	Low	0.7	150	1307,1308,1309	UP26-116	--	1/6	208-230	1.8	385	2.5µF/380V	Cast Iron	<h2>Mounting</h2> <p>Flow center is designed for indoor installation only.</p> <p>Flow center must be installed in an upright position as shown to the right.</p> <p>The pump terminal box should be located in one of the following orientations:</p> 
Part Number	Pump Motor	Speed	Nominal HP	Volts	Amps*	Watts*	Capacitor*	Pump Housing (Volute)																										
1304,1305,1306	UPS26-99	High	1/6	208-230	0.9	196	5µF/400V	Cast Iron																										
		Medium			0.8	179																												
		Low			0.7	150																												
1307,1308,1309	UP26-116	--	1/6	208-230	1.8	385	2.5µF/380V	Cast Iron																										
<h2>Pump Power Curves**</h2>  <p><small>**Power is per pump.</small></p>																																		
																																		

Appendix A

Pump Performance Curves

DESIGN NOTES:

1. The dual circuit flow center includes a pump(s) for each heat pump. The pump(s) for unit A is in parallel with the pump(s) for unit B. If one side has two pumps (e.g. NDP³ or NDP⁴), the two pumps on each side are in series. Page 4 shows a transparent view of the flow center with internal piping.
2. When sizing pumps for a dual circuit flow center, a pressure drop calculation should be done for the entire system when both heat pumps are running. Pump selection must be based upon both units running. For example, if the left side is a 3 ton heat pump with one pump, and the right side is a 2 ton heat pump with one pump; the pumps in parallel must be able to provide adequate flow and head when both units are running. Verify with online Calculators at www.geo-flo.com, or to manually select pumps, use the curves below, which include parallel operation.
3. The internal check valves and 3-way valves must be added to the system pressure drop before selecting pumps. Page 3 includes a chart based upon the flow rate for each heat pump.
4. All pump curves are manufacturer's reported averages using water at 68°F [20°C].



NDP²

Grundfos Pump Performance Curves: UPS26-99, UP26-116
(NDP²: one pump on LH side; one pump on RH side -- two pumps in parallel)

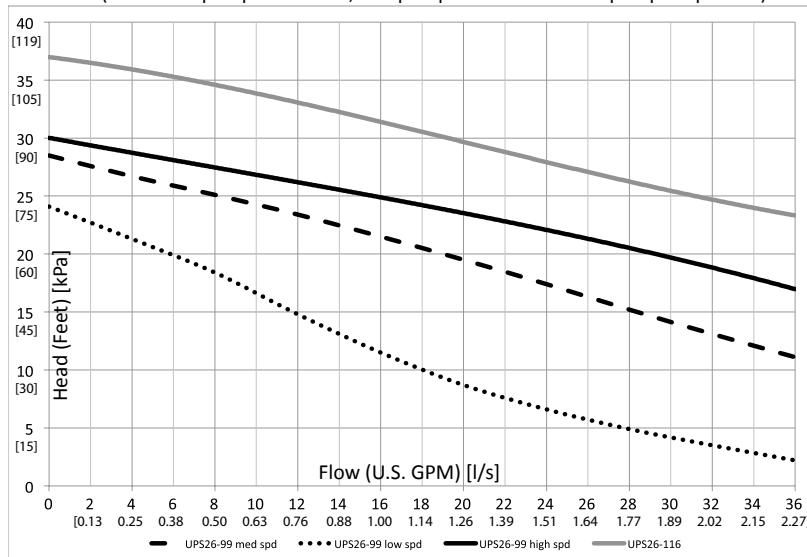

The NDP² flow center uses one UPS26-99 or one UP26-116 on each side. The chart to the left provides curves for these two pumps operating in parallel. Use these curves to determine pump selection when both heat pumps are operating. Two pumps in parallel provide twice the flow rate, but the head of only one pump. Internal check valves are factory-installed to prevent short circuiting.

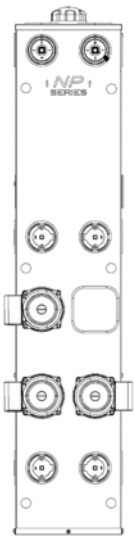

NDP³

Grundfos Pump Performance Curves, UPS26-99, high speed
(NDP³: two pumps in series on LH side; one pump on RH side -- two sets in parallel)

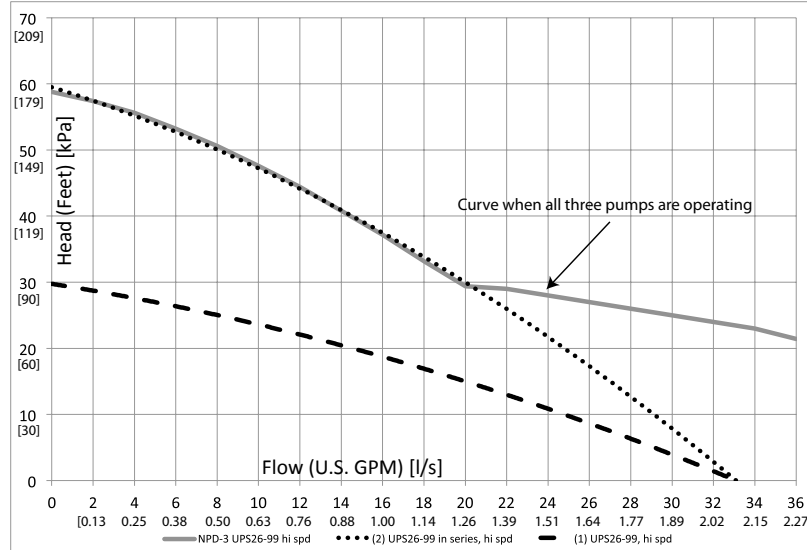

The NDP³ flow center uses two UPS26-99 or two UP26-116 pumps on side A and one UPS26-99 or one UPS26-116 pump on side B (UPS26-99 shown here--see next page for UP26-116). The chart to the left provides curves for these two sets of pumps operating in parallel. Use these curves to determine pump selection when both heat pumps are operating. Two pumps in parallel with one pump creates a curve that is the sum of the two curves (gray line). Internal check valves are factory-installed to prevent short circuiting.

Appendix A

Pump Performance Curves

Grundfos Pump Performance Curves, UP26-116
(NPD³: two pumps in series on LH side; one pump on RH side -- two sets in parallel)

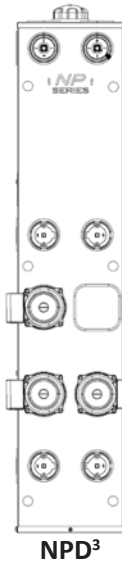
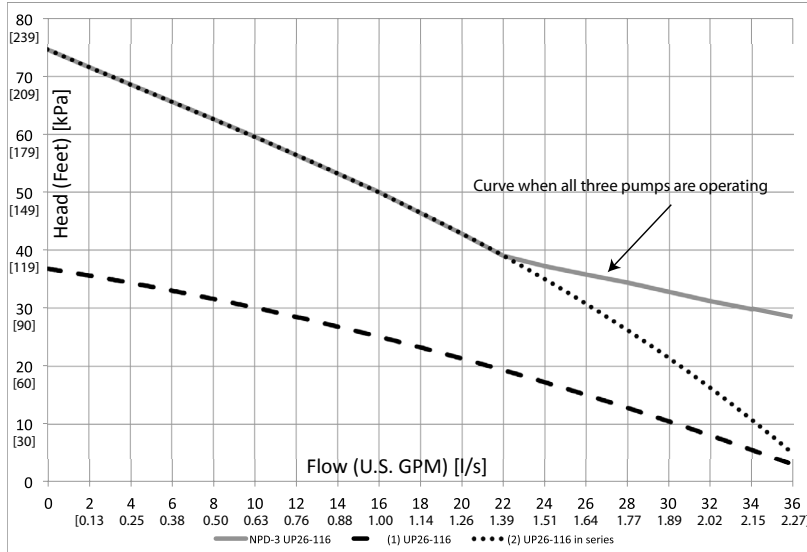

The NPD³ flow center uses two UPS26-99 or two UP26-116 pumps on side A and one UPS26-99 or one UPS26-116 pump on side B (UP26-116 shown here--see previous page for UPS26-99). The chart to the left provides curves for these two sets of pumps operating in parallel. Use these curves to determine pump selection when both heat pumps are operating. Two pumps in parallel with one pump creates a curve that is the sum of the two curves (gray line). Internal check valves are factory-installed to prevent short circuiting.

Grundfos Pump Performance Curves: UPS26-99, UP26-116

(NPD⁴: two pumps in series on LH side; two pumps in series on RH side -- two sets in parallel)

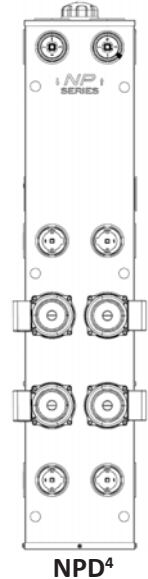
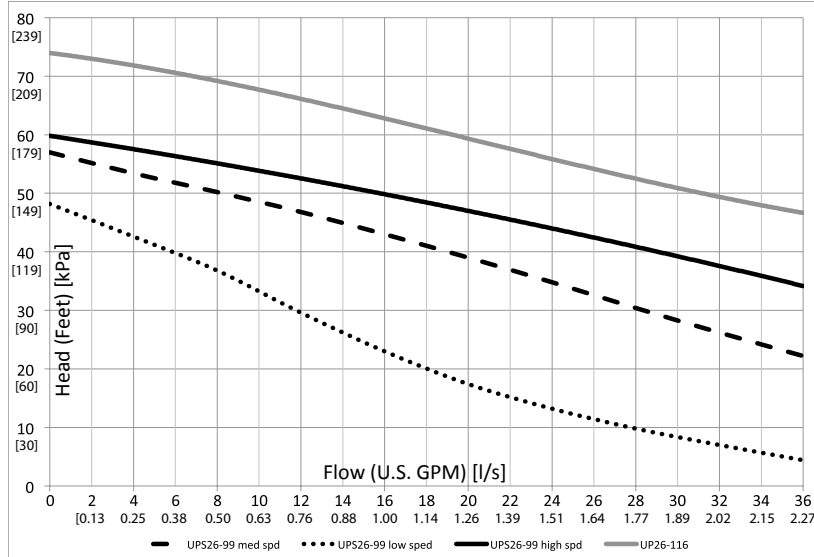

The NPD⁴ flow center uses two UPS26-99 pumps in series or two UP26-116 pumps in series on each side. The chart above provides curves for these two sets of pumps operating in parallel. Use these curves to determine pump selection when both heat pumps are operating. Two pumps in series with two pumps in parallel provide twice the flow rate and twice the head of one pump. Internal check valves are factory-installed to prevent short circuiting.

Use the chart on the right to account for the pressure drop of the internal components of the dual circuit flow center.

Pressure Drop Addition for Internal Check Valves and 3-Way Valves			
Side A	Flow Rate (GPM)		Tot. Press. Drop (ft. hd.)*
	Side B	Total	
6	6	12	2.3
	9	15	3.1
	12	18	4.2
	15	21	5.6
9	6	15	3.1
	9	18	4.1
	12	21	5.3
	15	24	6.8
12	6	18	4.2
	9	21	5.3
	12	24	6.7
	15	27	8.3
15	6	21	5.6
	9	24	6.8
	12	27	8.3
	15	30	10.1

*Includes internal check valves and 3-way valves.

Appendix A

Pump Performance Curves

The pump curves below represent the pumps on each side of the dual circuit flow center. For operation when only one heat pump is running, the curves below show a single pump or two pumps in series. For proper flow center selection, operation when both heat pumps are running must also be considered (previous pages).

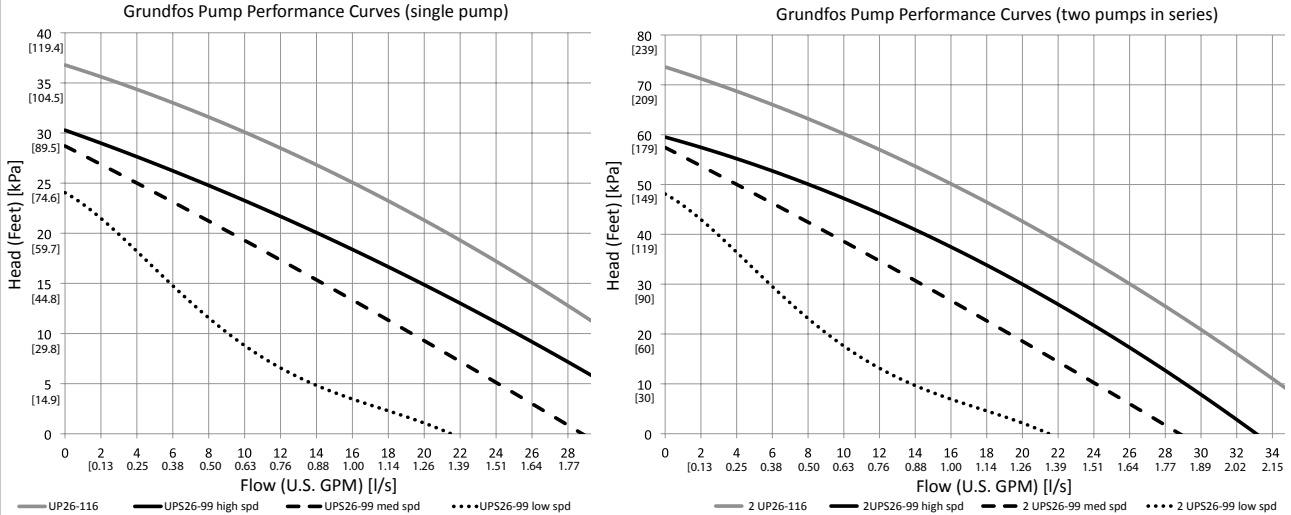

All pump curves are manufacturer's reported averages using water at 68°F [20°C].

Dimensional Data

	A	B	C	D	E	F	G	H	I	J	K
Inches	48-1/8	10	11-1/8	15	49-3/4	5	9-3/8	11	9-1/8	12	3/8" DRIVE SOCKET
CM	122.2	25.4	28.3	38.1	126.3	12.7	23.7	27.9	23.2	30.5	

Weight	Lbs	Kg
NPD-2	80.8	36.7
NPD-3	86.4	39.2
NPD-4	92.0	41.7

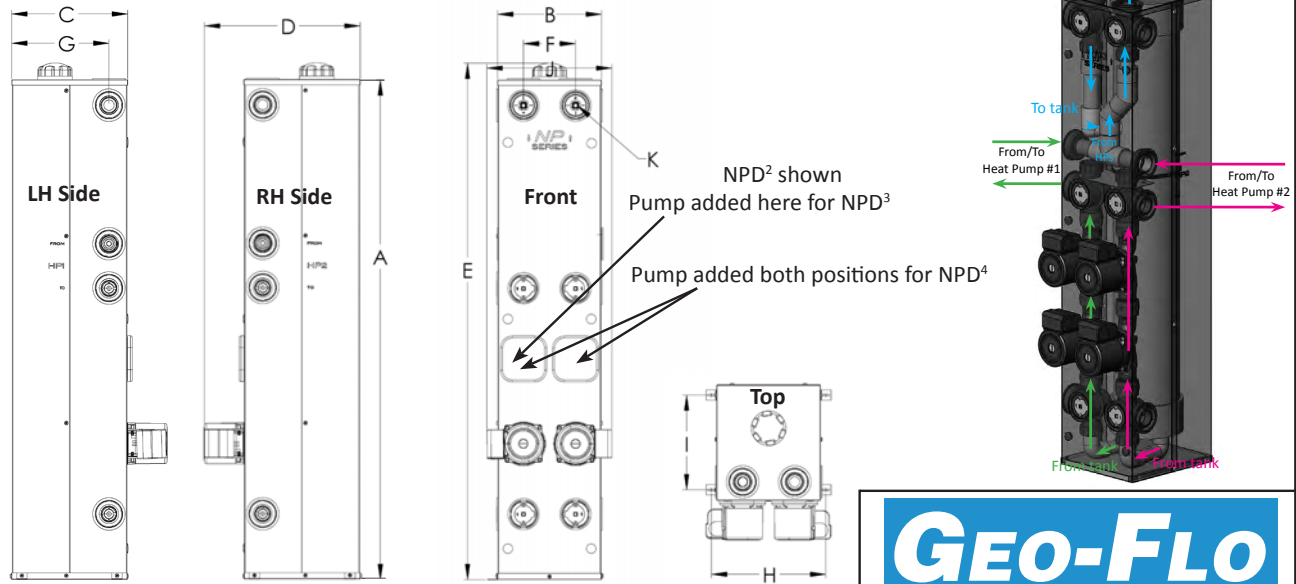

NOTE: All connections require Flo-Link™ (double O-ring) transition fittings. Internal check valves are factory-installed.

Manual Updates Table

Date	Description of Changes	Pages
11NOV2013	First published	All



Installation, Operating, and Maintenance Manual

NP Series Non-Pressurized Flow Centers

www.geo-flo.com

Members of ...



Geo-Flo Products Corporation is continually working to improve its products. As a result, the design and specifications of products in this catalog may change without notice and may not be as described herein. Statements and other information contained in this document are not express warranties and do not form the basis of any bargain between the parties, but are merely Geo-Flo's opinion or commendation of its products.