

Model Specific Instructions

NOTE: Read the entire instruction manual before starting the installation. Refer to Split-System Air Conditioner Common Installation and Start-Up Practices (included in this packet).

SAFETY CONSIDERATIONS

Improper installation, adjustment, alteration, service, maintenance, or use can cause explosion, fire, electrical shock, or other conditions which may cause death, personal injury, or property damage. Consult a qualified installer, service agency, or your distributor or branch for information or assistance. The qualified installer or agency must use factory-authorized kits or accessories when modifying this product. Refer to the individual instructions packaged with the kits or accessories when installing.

Follow all safety codes. Wear safety glasses, protective clothing, and work gloves. Use quenching cloth for brazing operations. Have fire extinguisher available. Read these instructions thoroughly and follow all warnings or cautions included in literature and attached to the unit. Consult local building codes and National Electrical Code (NEC) for special requirements.

Recognize safety information. This is the safety-alert symbol . When you see this symbol on the unit and in instructions or manuals, be alert to the potential for personal injury.

Understand the signal word DANGER, WARNING, or CAUTION. These words are used with the safety-alert symbol. DANGER identifies the most serious hazards which **will** result in severe personal injury or death. WARNING signifies hazards which **could** result in personal injury or death. CAUTION is used to identify unsafe practices which **would** result in minor personal injury or product and property damage.

WARNING

Before installing, modifying, or servicing system, main electrical disconnect switch must be in the OFF position. There may be more than 1 disconnect switch. Lock out and tag switch with a suitable warning label. Electrical shock can cause personal injury or death.

INSTALLATION

Step 1—Mount Unit to Pad

Refer to Fig. 1 for pad dimensions and dimensions needed to mount unit to pad.

Step 2—Refrigerant Tubing

Refer to Fig. 2 for refrigerant tube dimensions and connections.

Step 3—Mechanical Connection (38CKN Models)

1. Cut tubing to the correct length, deburr, and size as necessary, making sure tube ends are square. If a large burr is evident, the ID and OD must be deburred to allow tube to bottom in valve.
2. Remove lock nuts and ferrules from plastic bags taped to service panel. (See Fig. 3.)

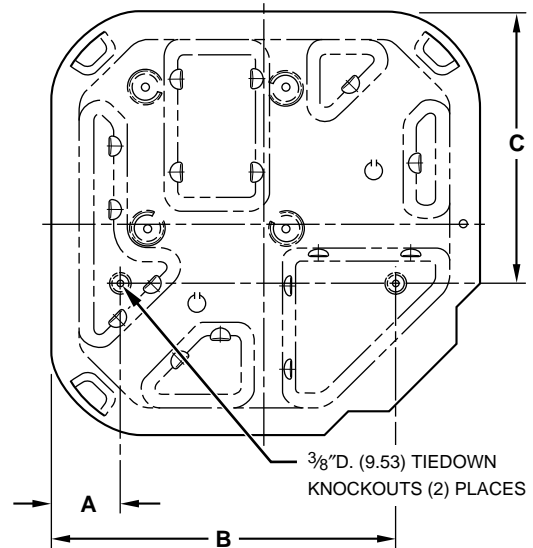

A94199

UNIT SIZE	MIN. PAD DIM. (IN.)	TIEDOWN KNOCKOUT LOCATIONS		
		A (In.)	B (In.)	C (In.)
38CKB(N)018, 024	18 X 18	3	15	10-3/16
38CKB(N)030-042 38CMB018-030	22-1/2 X 22-1/2	3-11/16	18-1/8	14-3/8
38BRB024-060 38CKB(N)048, 060 38CMB036-060	30 X 30	6-1/2	23-1/2	20

Fig. 1—Mount Unit to Pad

CAUTION

If undersized, damaged, or elliptically shaped tubing is used when making connection, leaks could result.

3. Slide the lock nut and ferrule onto each tube. (See Fig. 4.)
4. Apply a few drops of refrigerant oil to the ferrule and valve threads to reduce assembly torque and assist sealing.
5. Insert tube end into service valve until it bottoms.
6. Push the ferrule into place and hand tighten the nut until an increase in torque is felt.
7. Mark the nut and tube and tighten 1-1/2 turns from the mark. (See Fig. 5.) Keep the tube bottomed in the valve while tightening nut.

NOTE: A backup wrench on the hex part of the suction valve is required while tightening.

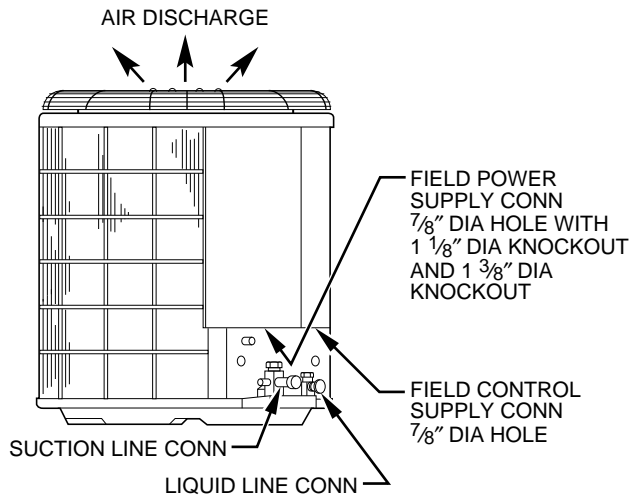

A93578

UNIT SIZE	LIQUID TUBE		VAPOR TUBE	
	Conn Dia	Tube Dia	Conn Dia	Tube Dia
018, 024	3/8	3/8	5/8	5/8
030, 036	3/8	3/8	3/4	3/4
042, 048	3/8	3/8	7/8	7/8
060	3/8	3/8	7/8	1-1/8

Tube diameters are for lengths up to 50 ft. For tubing lengths greater than 50 ft, consult your local distributor.

Fig. 2—Refrigerant Tube Dimensions/Connections

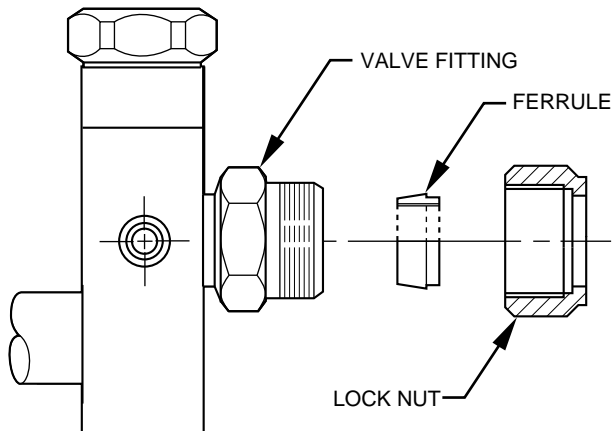

A92120

Fig. 3—Mechanical Fitting Assembly (38CKN)

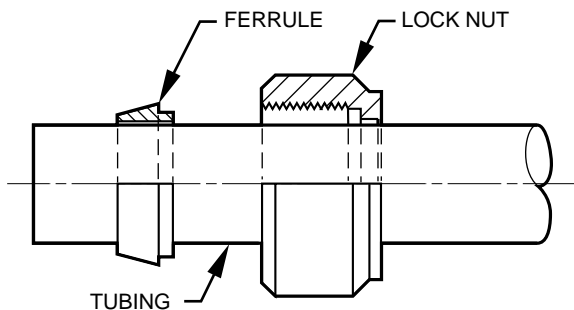

A92121

Fig. 4—Lock Nut/Ferrule Positioning (38CKN)

CAUTION

The tube end must stay bottomed in the service valve during final assembly to ensure proper seating, sealing, and rigidity.

MECHANICAL FITTING REPAIR

To replace damaged ferrule or tubing proceed as follows.

1. Attach gages to service valves.
2. Close liquid service valve and operate unit to pump refrigerant charge into condenser coil.
3. When suction pressure reaches 5 psig, shut unit off. Do not operate unit in a vacuum.
4. Close suction service valve and recover refrigerant in tubing.
5. Back-off locknut and ferrule onto tube.
6. Remove damaged part of tubing using tubing cutter. Repeat installation procedure previously outlined using new ferrule.
7. Evacuate tubing set and indoor coil. Check for leaks.
8. Open service valves or recharge unit. Check refrigerant charge.

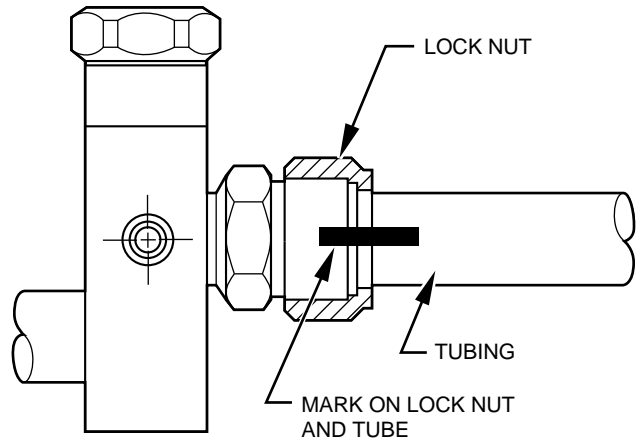

A92122

Fig. 5—Proper Marking of Valve Assembly (38CKN)

Step 4—Install Solenoid Valve In Liquid Tube (If Required)

CAUTION

Not all applications require use of a liquid tube solenoid valve. If your unit has been shipped with a liquid tube solenoid valve in the unit, it must be installed for performance enhancement. The liquid tube solenoid valve must be energized during evacuation for complete removal of refrigerant.

Before making liquid tube connections, install factory-supplied solenoid valve on indoor liquid fitting. (See Fig. 6.) Be sure to use flare adapter supplied with the indoor coil when making connections.

CAUTION

Wiring must comply with local codes and NEC requirements, if a field-supplied control power source is needed when adding solenoid.

1. Remove coil liquid connection cap and discard.
2. Mount solenoid valve on liquid tube, making sure valve flow arrow points toward indoor coil. Mount valve in any position except valve body at top and electric coil at bottom. (See Fig.

6.) The solenoid valve is to be installed a maximum of 2 ft from indoor coil.

⚠ CAUTION

Avoid valve damage while brazing by wrapping valve with a heat-sinking material such as a wet cloth.

3. Braze valve onto end of liquid tube using silver bearing or non-silver bearing brazing material. Consult local code requirements.
4. Braze flare adapter onto outlet end of solenoid valve.
5. Wire solenoid coil into system control circuit.

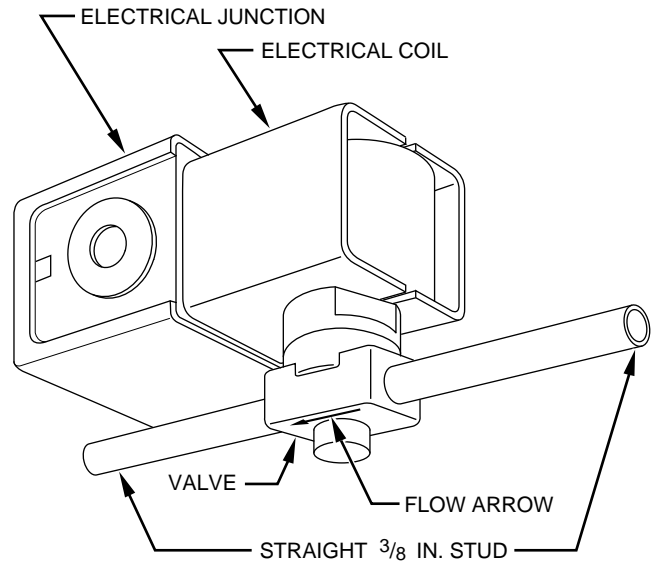

NOTE: System flow direction must match arrow on bottom of body.

A87044

Fig. 6—Solenoid Valve Installation

SERVICE TRAINING

Packaged Service Training programs are an excellent way to increase your knowledge of the equipment discussed in this manual, including:

- Unit Familiarization
- Maintenance
- Installation Overview
- Operating Sequence

A large selection of product, theory, and skills programs is available, using popular video-based formats and materials. All include video and/or slides, plus companion book.

Classroom Service Training plus "hands-on" the products in our labs can mean increased confidence that really pays dividends in faster troubleshooting, fewer callbacks. Course descriptions and schedules are in our catalog.

CALL FOR FREE CATALOG 1-800-962-9212

Packaged Service Training

Classroom Service Training

A94328