

**38CKE – 50 Hz  
Split System Air Conditioner  
with Puron Refrigerant  
1 – 1/2 to 5 Tons**



Turn to the Experts.™



IP24

(048 & 060 sizes only)

# Installation Instructions

## SAFETY CONSIDERATIONS

Improper installation, adjustment, alteration, service, maintenance, or use can cause explosion, fire, electrical shock, or other conditions which may cause death, personal injury, or property damage. Consult a qualified installer, service agency, or your distributor or branch for information or assistance. The qualified installer or agency must use factory-authorized kits or accessories when modifying this product. Refer to the individual instructions packaged with the kits or accessories when installing.

Follow all safety codes. Wear safety glasses, protective clothing, and work gloves. Use quenching cloth for brazing operations. Have fire extinguisher available. Read these instructions thoroughly and follow all warnings or cautions included in literature and attached to the unit. Consult local building codes and current editions of the National Electrical Code (NEC) NFPA 70. In Canada, refer to current editions of the Canadian electrical code CSA 22.1.

Recognize safety information. This is the safety-alert symbol ⚠. When you see this symbol on the unit and in instructions or manuals, be alert to the potential for personal injury. Understand these signal words; DANGER, WARNING, and CAUTION. These words are used with the safety-alert symbol. DANGER identifies the most serious hazards which **will** result in severe personal injury or death. WARNING signifies hazards which **could** result in personal injury or death. CAUTION is used to identify unsafe practices which **would** result in minor personal injury or product and property damage. NOTE is used to highlight suggestions which **will** result in enhanced installation, reliability, or operation.



## WARNING

### ELECTRICAL SHOCK HAZARD

Failure to follow this warning could result in personal injury or death.

Before installing, modifying, or servicing system, main electrical disconnect switch must be in the OFF position. There may be more than 1 disconnect switch. Lock out and tag switch with a suitable warning label.



## WARNING

### UNIT OPERATION AND SAFETY HAZARD

Failure to follow this warning could result in personal injury or equipment damage.

R-410A refrigerant systems operate at higher pressures than standard R-22 systems. Do not use R-22 service equipment or components on R-410A refrigerant equipment.

## INSTALLATION RECOMMENDATIONS

**NOTE:** In some cases noise in the living area has been traced to gas pulsations from improper installation of equipment.

1. Locate unit away from windows, patios, decks, and so forth, where unit operation sound may disturb customer.
2. Insure that vapor- and liquid-tube diameters are appropriate to capacity of unit.
3. Run refrigerant tubes as directly as possible by avoiding unnecessary turns and bends.
4. Leave some slack between structure and unit to absorb vibration.
5. When passing refrigerant tubes through the wall, seal opening with RTV or other pliable silicon-based caulk. (See Fig. 1.)
6. Avoid direct tubing contact with water pipes, duct work, floor joists, wall studs, floors, and walls.
7. Do not suspend refrigerant tubing from joists and studs with a rigid wire or strap that comes in direct contact with tubing. (See Fig. 1.)
8. Ensure that tubing insulation is pliable and completely surrounds vapor tube.
9. When necessary, use hanger straps which are 1 in. wide and conform to shape of tubing insulation. (See Fig. 1.)
10. Isolate hanger straps from insulation by using metal sleeves bent to conform to shape of insulation.

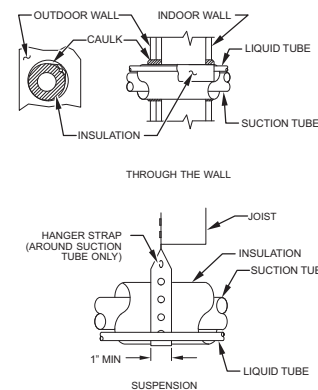

A07588

**Fig. 1 – Connecting Tubing Installation  
GENERAL**

## INSPECT NEW UNIT

File claim with shipping company prior to installation if shipment is damaged or incomplete. Locate unit rating plate on unit service panel. It contains information needed to properly install unit. Check rating plate to be sure unit matches job specifications.

## LOCATION

Check local codes for regulations concerning zoning, noise, platforms, and other issues.

Locate unit away from fresh air intakes, vents, or bedroom windows. Noise may carry into the openings and disturb people inside.

Locate unit in a well drained area, or support unit high enough so that water runoff will not enter the unit.

Locate unit away from areas where heat, lint, or exhaust fumes will be discharged onto unit (as from dryer vents).

Locate unit away from recessed or confined areas where recirculation of discharge air may occur (refer to CLEARANCES section of this document).

Roof-top installation is acceptable providing the roof will support the unit and provisions are made for water drainage and noise/vibration dampening.

**NOTE:** Roof mounted units exposed to wind may require wind baffles. Consult the manufacturer for additional information.

## INSTALL ON SOLID, LEVEL MOUNTING PAD

If conditions or local codes require the unit be attached to pad, tie-down bolts should be used and fastened through knockouts provided in unit base pan. Refer to unit mounting pattern in Fig. 2 to determine base pan size and knockout hole location.

Arrange supporting members to adequately support unit and minimize transmission of vibration to building. Consult local codes governing rooftop applications.

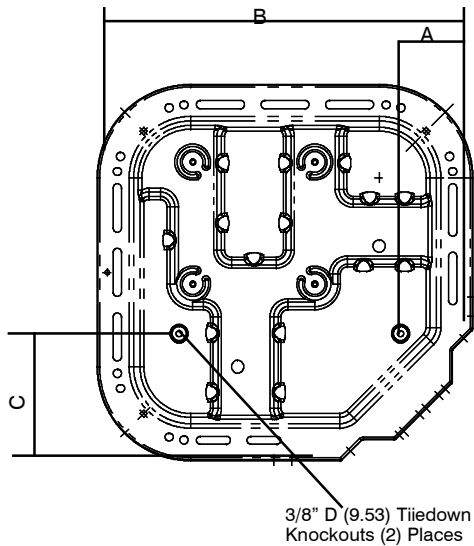

Base Pan Width x Depth in. (mm)	Tie Down Knockouts in. (mm)			Minimum Mounting Pad Dimensions in. (mm)
	A	B	C	
23-1/2 X 23-1/2 (596.9 X 596.9)	4-7/19 (111.0)	18-1/16 (458.8)	7-3/16 (182.6)	26 x 26 (660 x 660)
31-1/2 X 31-1/2 (800.1 X 800.1)	6-9/16 (166.7)	24-11/16 (627.1)	9-1/8 (231.8)	35 X 35 (889 x 889)

A08073

Fig. 2 – Tie Down Knockouts

## CLEARANCE REQUIREMENTS

When installing, allow sufficient space for airflow clearance, wiring, refrigerant piping, and service. Allow 24 in. (609.6 mm) clearance to service end of unit and 48 in. (1219.2 mm) (above unit. For proper airflow, a 6-in. (152.4 mm) clearance on 1 side of unit and 12-in. (304.8 mm) on all remaining sides must be maintained. Maintain a distance of 24 in. (609.6 mm) between units or 18 in. (457.2 mm) if no overhang within 12 ft. (3.66 m) Position so water, snow, or ice from roof or eaves cannot fall directly on unit.

**NOTE:** 18 in. (457.2 mm) clearance option described above is approved for outdoor units with wire grille coil guard only. Units with louver panels require 24 in. (609.6 mm) between units.

On rooftop applications, locate unit at least 6 in. (152.4 mm) above roof surface.

## OPERATING AMBIENT

The minimum outdoor operating ambient in cooling mode is 55°F (12.78°C), and the maximum outdoor operating ambient in cooling mode is 125°F (51.67°C).

## EXPANSION DEVICE

When combined with a Carrier indoor product, a hard shutoff, thermostatic expansion valve (TXV) is required at the indoor section of the system for proper operation.

## FILTER DRIER

A field installed liquid-line filter drier is recommended for this installation.

Refer to Fig. 3 and install filter drier as follows:

1. Braze 5 in. (127 mm) liquid tube to the indoor coil.
2. Wrap filter drier with damp cloth.
3. Braze filter drier to above 5 in. (127 mm) liquid tube. Flow arrow must point toward indoor coil.
4. Connect and braze liquid refrigerant tube to the filter drier.

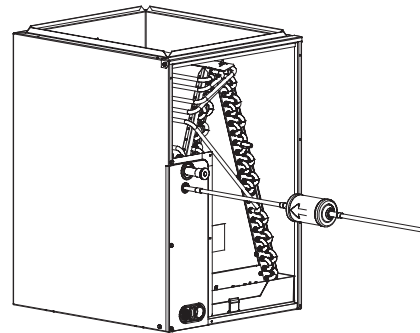

A05227

Fig. 3 – Liquid Line Filter Drier Installed at Outdoor Unit

## MAKE REFRIGERANT TUBING CONNECTIONS

Outdoor units may be connected to indoor section using accessory tubing package or field supplied refrigerant-grade tubing of correct size and condition. For tubing requirements beyond 80 ft (24.38 m), consult Residential Split System Long-Line Application Guideline. Connect tubing to fittings on outdoor unit vapor and liquid service lines. (See Table 1.)

If refrigerant tubes or the indoor coil are exposed to atmospheric conditions for longer than 5 minutes they must be evacuated to 500 microns to eliminate contamination and moisture in system.

**Table 1—Refrigerant Connections and Recommended Liquid and Vapor Tube Diameters (in.)**

UNIT SIZE	Liquid		Rated Vapor*	
	Connect Diameter	Tube Diameter	Connect Diameter	Tube Diameter
018, 024, 030	3/8	3/8	3/4	3/4
036, 042, 048			7/8	7/8
060			7/8	1-1/8

\* Units are rated with 25 ft. (7.6 m) of lineset. See Product Data sheet for performance data when using different size and length linesets.

### Notes:

- Do not apply capillary tube or fixed orifice indoor coils to these units.
- For Tubing Set lengths between 80 and 200 ft. (24.38 and 60.96 m) horizontal or 35 ft. (10.7 m) vertical differential 250 ft. (76.2 m) Total Equivalent Length), refer to the Residential Piping and Longline Guide line— Air Conditioners and Heat Pumps using Puron refrigerant.

## OUTDOOR UNIT CONNECTED TO FACTORY APPROVED INDOOR UNIT

Outdoor unit contains correct system refrigerant charge for operation with indoor unit of same size when connected by 15 ft (4.57 m) of field supplied or factory accessory tubing. Check refrigerant charge for maximum efficiency.

## SWEAT CONNECTION

### ⚠ CAUTION

#### UNIT DAMAGE HAZARD

Failure to follow this caution may result in unit component damage.

Service valves must be wrapped while brazing in a heat sink material, such as a wet cloth.

Use refrigerant grade tubing. Service valves are closed from factory and ready for brazing. After wrapping service valve with a wet cloth, tubing set can be brazed to service valve using industry accepted methods and materials. Consult local code requirements. Refrigerant tubing and indoor coil are now ready for leak testing. This check should include all field and factory joints.

## MAKE ELECTRICAL CONNECTIONS

### ⚠ WARNING

#### ELECTRICAL SHOCK HAZARD

Failure to follow this warning could result in personal injury or death.

Do not supply power to unit with compressor terminal box cover removed.

Be sure field wiring complies with local and national fire, safety, and electrical codes, and voltage to system is within limits shown on unit rating plate. Contact local power company for correction of improper voltage. See unit rating plate for recommended circuit protection device.

**NOTE:** Operation of unit on improper line voltage constitutes abuse and could affect unit reliability. See unit rating plate. Do not install unit in system where voltage or phase imbalance (3 phase) may fluctuate above or below permissible limits.

**NOTE:** Use copper wire only between disconnect switch and unit.

**NOTE:** Install branch circuit disconnect of adequate size per NEC to handle unit starting current. Locate disconnect within sight from and readily accessible from unit, per Section 440-14 of NEC.

## ROUTE GROUND AND POWER WIRES

Remove access panel to gain access to unit wiring. Extend wires from disconnect through power wiring hole provided and into unit control box.

### ⚠ WARNING

#### ELECTRICAL SHOCK HAZARD

Failure to follow this warning could result in personal injury or death.

The unit cabinet must have an uninterrupted or unbroken ground. The ground may consist of electrical wire or metal conduit when installed in accordance with existing electrical codes.

## CONNECT GROUND AND POWER WIRES

Connect ground wire to ground connection in control box for safety. Connect power wiring to contactor as shown in Fig. 4

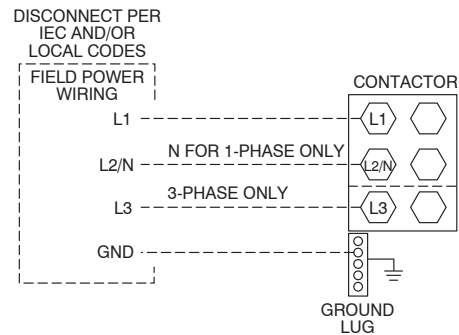

**Fig. 4 – Line Power Connections**

A03226

## CONNECT CONTROL WIRING

Route 24v control wires through control wiring grommet and connect leads to control wiring. (See Fig. 5.)

Use No. 18 AWG color coded, insulated (35°C minimum) wire. If thermostat is located more than 100 ft from unit, as measured along the control voltage wires, use No. 16 AWG color coded wire to avoid excessive voltage drop.

Use furnace transformer, fan coil transformer, or accessory transformer for control power, 24v/40va minimum.

**NOTE:** Use of available 24v accessories may exceed the minimum 40va power requirement. Determine total transformer loading and increase the transformer capacity or split the load with an accessory transformer as required.

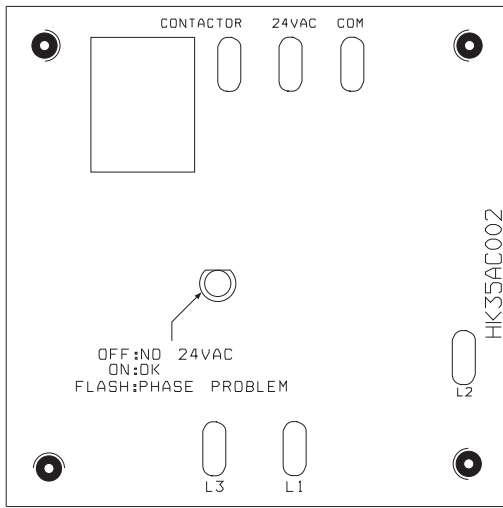

Fig. 5 – 3 Phase Monitor Control

A00010

Table 2—Phase-Monitor LED Indicators

LED	STATUS
OFF	No call for compressor operation
FLASHING	Reversed phase
ON	Normal

## CAUTION

### UNIT DAMAGE HAZARD

Failure to follow this caution may result in unit damage.

- 3-phase scroll compressors are rotation sensitive.
- A flashing LED on phase monitor indicates reverse rotation. (See Fig. 5 and Table 2.)
- This will not allow contactor to be energized.
- Disconnect power to unit and interchange 2 field wiring leads on unit contactor.

### COMPRESSOR CRANKCASE HEATER

A crankcase heater is required if refrigerant tubing is longer than 80 ft. (24.38 m).

When equipped with a crankcase heater, energize heater a minimum of 24 hours before starting unit. To energize heater only, set thermostat to OFF mode and close electrical disconnect to outdoor unit.

### INSTALL ELECTRICAL ACCESSORIES

Refer to individual instructions packaged with kits or accessories when installing.

### START-UP

## CAUTION

### UNIT DAMAGE AND/OR PERSONAL INJURY HAZARD

Failure to follow this caution may result in personal injury and/or unit component damage.

Service valve gauge ports are equipped with Schrader valves. Wear safety glasses and gloves when handling refrigerant.

1. Fully open liquid and vapor service valves.
2. Unit is shipped with valve stem(s) front seated (closed) and caps installed. Replace stem caps after system is opened to refrigerant flow. Replace caps finger-tight and tighten an additional 1/12 turn with wrench.
3. Close electrical disconnects to energize system.

4. Set room thermostat at desired temperature. Be sure set point is below indoor ambient temperature.

5. Set room thermostat to COOL and fan control to ON or AUTO mode. Operate unit for 15 minutes. Check system-refrigerant charge. (See Check Charge.)

## WARNING

### PERSONAL INJURY and ENVIRONMENTAL HAZARD

Failure to relieve system pressure could result in personal injury and/or death.

1. Relieve pressure and recover all refrigerant before servicing existing equipment, and before final unit disposal. Use all service ports and open all flow-control devices, including solenoid valves.

2. Federal regulations require that you do not vent refrigerant into the atmosphere. Recover during system repair or final unit disposal.

### SEQUENCE OF OPERATION

Turn on power to indoor and outdoor units. Transformer is energized.

On a call for cooling, thermostat makes circuits R-Y and R-G. Three phase models with scroll compressors, are equipped with a phase monitor to detect if the incoming power is correctly phased for compressor operation. (See Fig. 5 and Table 2.) If the phasing is correct, circuit R-Y energizes contactor, starting outdoor fan motor and compressor circuit. R-G energizes indoor unit blower relay, starting indoor blower motor on high speed.

**NOTE:** If the phasing is incorrect, the contactor will not be energized. To correct the phasing, interchange any two of the three power connections on the field side.

When thermostat is satisfied, its contacts open, de-energizing contactor and blower relay. Compressor and motors stop.

If indoor unit is equipped with an off delay circuit, the indoor blower can run an additional 120 sec to increase system efficiency.

### CHECK CHARGE

Factory charge amount is shown on unit rating plate.

#### Cooling Only Procedure

**NOTE:** If superheat or subcooling charging conditions are not favorable, charge must be weighed in accordance with unit rating plate  $\pm 0.6$  oz/ft of 3/8-in. (56g/m of 9.5 mm) liquid line above or below 15 ft (7.6 m) respectively.

EXAMPLE:

To calculate additional charge required for a 10 m line set:

$10 \text{ m} - 7.6 \text{ m} = 2.4 \text{ m} \times 56 \text{ g/m} = 134.4 \text{ g}$  of additional charge

The following procedure is valid when indoor airflow is within  $\pm 21$  percent of its rated CFM:

1. Operate unit a minimum of 10 minutes before checking charge.
2. Measure suction pressure by attaching an accurate gage to suction valve service port.
3. Measure suction temperature by attaching an accurate thermistor type or electronic thermometer to suction line near service valve.
4. Measure outdoor air dry bulb temperature with thermometer.
5. Measure indoor air (entering indoor coil) wet bulb temperature with a sling psychrometer.
6. Refer to Table 3. Find outdoor temperature and evaporator entering air wet bulb temperature. At this intersection, note superheat.

7. Refer to Table 4. Find superheat temperature located in item 6 and suction pressure. At this intersection, note suction line temperature.
8. If a unit has a higher suction line temperature than charted temperature, add refrigerant until charted temperature is reached.
9. If unit has a lower suction line temperature than charted temperature, reclaim refrigerant until charted temperature is reached.
10. When adding refrigerant, charge in liquid form into suction service port using a flow-restricting device.
11. If outdoor air temperature or pressure at suction valve changes, charge to new suction line temperature indicated on chart.

**NOTE:** If line length is beyond 80 ft (24.38 m) or greater than 20 ft (6.10 m) vertical separation, See Long Line Guideline for special charging requirements.

**▲ CAUTION**

**UNIT DAMAGE HAZARD**

Failure to follow this caution may result in unit damage.  
Compressor damage may occur if system is overcharged.

**Table 3—Superheat Charging Table (SI)**

OUTDOOR TEMP (°C)	EVAPORATOR ENTERING AIR TEMPERATURE (°C WB)														
	10	11	12	13	14	15	16	17	18	19	20	21	22	23	24
13	5.0	6.7	7.8	9.4	11.1	11.9	12.8	14.4	16.1	17.8	19.4	20.6	22.2	23.3	25.0
16	3.9	5.6	6.7	8.3	10.0	10.8	11.7	13.3	15.0	16.7	18.3	20.0	21.1	22.2	23.9
18	–	3.3	5.6	7.2	8.9	9.7	10.6	11.7	13.3	15.0	16.7	18.3	20.0	21.1	22.8
21	–	–	3.9	5.6	7.2	8.1	8.9	10.6	11.7	13.3	15.0	16.7	18.3	20.0	21.7
24	–	–	–	3.3	5.0	5.8	6.7	8.3	10.0	11.7	7.8	15.6	17.2	18.9	20.6
27	–	–	–	–	2.8	3.6	4.4	6.7	8.3	10.0	11.7	13.9	15.6	17.2	19.4
29	–	–	–	–	–	–	–	4.4	6.1	8.3	10.6	12.2	14.4	16.7	18.3
32	–	–	–	–	–	–	–	2.8	5.0	7.2	8.9	11.1	13.3	15.0	17.2
35	–	–	–	–	–	–	–	–	3.3	5.6	7.8	10.0	12.2	13.9	16.1
38	–	–	–	–	–	–	–	–	–	4.4	6.7	8.3	11.1	12.8	15.0
41	–	–	–	–	–	–	–	–	–	2.8	5.0	7.2	9.4	12.2	14.4
43	–	–	–	–	–	–	–	–	–	–	3.3	6.1	8.3	11.1	13.9
46	–	–	–	–	–	–	–	–	–	–	–	4.4	7.8	10.0	12.8

Where a dash (–) appears, do not attempt to charge system under these conditions, or refrigerant slugging may occur. Charge must be weighed in.

**NOTE:** Superheat °C is at low–side service port.

**Table 4—Required Suction-Line Temperature (°C)**

SUPERHEAT TEMP (°C)	SUCTION PRESSURE AT SERVICE PORT (KPA)									
	743	774	805	836	869	902	957	971	1005	
0	1.7	2.8	3.9	5.0	6.1	7.2	8.3	9.4	10.6	
1	2.8	3.9	5.0	6.1	7.2	8.3	9.4	10.6	11.7	
2	3.9	5.0	6.1	7.2	8.3	9.4	10.6	11.7	12.8	
3	5.0	6.1	7.2	8.3	9.4	10.6	11.7	12.8	13.9	
4	6.1	7.2	8.3	9.4	10.6	11.7	12.8	13.9	15.0	
6	7.2	8.3	9.4	10.6	11.7	12.8	13.9	15.0	16.1	
7	8.3	9.4	10.6	11.7	12.8	13.9	15.0	16.1	17.2	
8	9.4	10.6	11.7	12.8	13.9	15.0	16.1	17.2	18.3	
9	10.6	11.7	12.8	13.9	15.0	16.1	17.2	18.3	19.4	
10	11.7	12.8	13.9	15.0	16.1	17.2	18.3	19.4	20.6	
11	12.8	13.9	15.0	16.1	17.2	18.3	19.4	20.6	21.7	
12	13.9	15.0	16.1	17.2	18.3	19.4	20.6	21.7	22.8	
13	15.0	16.1	17.2	18.3	19.4	20.6	21.7	22.8	23.9	
14	16.1	17.2	18.3	19.4	20.6	21.7	22.8	23.9	25.0	
15	16.7	17.8	18.9	20.0	21.1	22.2	23.3	24.4	25.6	
16	17.2	18.3	19.4	20.6	21.7	22.8	23.9	25.0	26.1	
17	18.3	19.4	20.6	21.7	22.8	23.9	25.0	26.1	27.2	
18	19.4	20.6	21.7	22.8	23.9	25.0	26.1	27.2	28.3	
19	20.6	21.7	22.8	23.9	25.0	26.1	27.2	28.3	29.4	
20	21.7	22.8	23.9	25.0	26.1	27.2	28.3	29.4	30.6	
21	22.8	23.9	25.0	26.1	27.2	28.3	29.4	30.6	31.7	
22	23.9	25.0	26.1	27.2	28.3	29.4	30.6	31.7	32.8	

## CARE AND MAINTENANCE

For continuing high performance and to minimize possible equipment failure, it is essential that periodic maintenance be performed on this equipment. Consult your servicing contractor or Owner's Manual for proper frequency of maintenance. Frequency of maintenance may vary depending upon geographic areas, such as coastal applications.

Leave Owner's Manual with homeowner. Explain system operation and maintenance procedures outlined in manual.

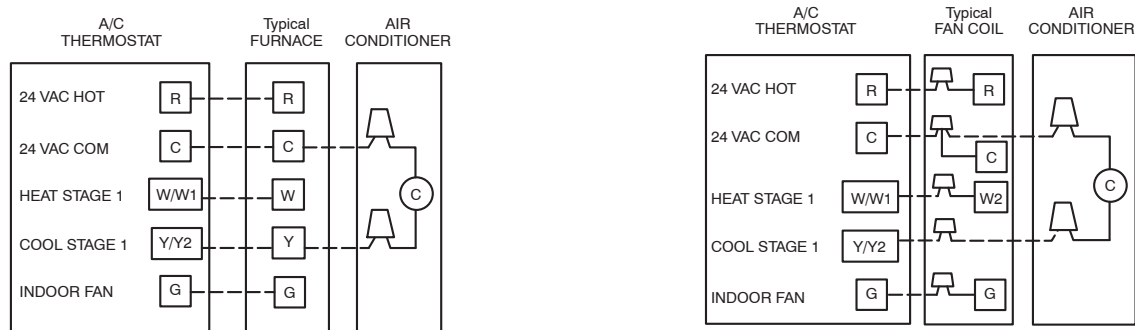

A002326

**Fig. 6 – Generic Wiring Diagrams**  
 (See Thermostat Installation Instructions for wiring specific unit combinations)

### R-410A REFRIGERANT QUICK REFERENCE GUIDE

- R-410A refrigerant operates at 50-70 percent higher pressures than R-22. Be sure that servicing equipment and replacement components are designed to operate with R-410A refrigerant.
- R-410A refrigerant cylinders are rose colored.
- Recovery cylinder service pressure rating must be 400 psig, DOT 4BA400 or DOT BW400.
- R-410A refrigerant systems should be charged with liquid refrigerant. Use a commercial type metering device in the manifold hose when charging into suction line with compressor operating.
- Manifold sets should be 700 psig high side and 180 psig low side with 550 psig low-side retard.
- Use hoses with 700 psig service pressure rating.
- Leak detectors should be designed to detect HFC refrigerant.
- R-410A refrigerant, as with other HFCs, is only compatible with POE oils.
- Vacuum pumps will not remove moisture from oil.
- Do not use liquid-line filter driers with rated working pressures less than 600 psig.
- Do not leave R-410A refrigerant suction line filter driers in line longer than 72 hours.
- Do not install a suction-line filter drier in liquid-line.
- POE oils absorb moisture rapidly. Do not expose oil to atmosphere.
- POE oils may cause damage to certain plastics and roofing materials.
- Wrap all filter driers and service valves with wet cloth when brazing.
- A factory-approved liquid-line filter drier is required on every unit.
- Do NOT use an R-22 TXV.
- If indoor unit is equipped with an R-22 TXV, it must be changed to a hard-shutoff R-410A refrigerant TXV.
- Never open system to atmosphere while it is under a vacuum.
- When system must be opened for service, recover refrigerant, evacuate then break vacuum with dry nitrogen and replace filter driers. Evacuate to 500 microns prior to recharging.
- Do not vent R-410A refrigerant into the atmosphere.
- Do not use capillary tube coils.
- Observe all **warnings, cautions, and bold text**.
- All indoor coils must be installed with a hard-shutoff R-410A refrigerant TXV metering device.