

40GRQ / 619FB / 38GRQ / 538FR

High-Wall Ductless Split System

Sizes 09 - 18

Installation Instruction

NOTE: Read the entire instruction manual before starting the installation.



TABLE OF CONTENTS

	PAGE
SAFETY CONSIDERATIONS	2
GENERAL	2
SYSTEM REQUIREMENTS	2
Piping	2
DIMENSIONS- INDOOR	4
DIMENSIONS- OUTDOOR	5
CLEARANCES- INDOOR	6
CLEARANCES- OUTDOOR	6
INSTALLATION GUIDE	7
INDOOR UNIT INSTALLATION	7
Install Mounting Plate	7
Drill Hole in Wall for Interconnecting Piping, Drain and Wiring	7
OUTDOOR UNIT INSTALLATION	8
Piping Connections to Outdoor Unit	8
INSTALL ALL POWER, INTERCONNECTING WIRING AND PIPING TO INDOOR UNIT	9
SYSTEM VACUUM AND CHARGE	9
START-UP	11
WIRING DIAGRAMS	12
TROUBLESHOOTING	13

The following parts are included in your indoor unit. Please contact your dealer if any parts are damaged or missing.

Table 1—Parts List

Parts	Qty
Mounting Plate	1
Mounting Hardware	7
Remote Control	1
Remote Control Holder	1
Battery (1.5V)	2

SAFETY CONSIDERATIONS

Installing, starting up, and servicing air-conditioning equipment can be hazardous due to system pressures, electrical components, and equipment location (roofs, elevated structures, etc.).

Only trained, qualified installers and service mechanics should install, start-up, and service this equipment.

Untrained personnel can perform basic maintenance functions such as cleaning coils. All other operations should be performed by trained service personnel.

When working on the equipment, observe precautions in the literature and on tags, stickers, and labels attached to the equipment.

Follow all safety codes. Wear safety glasses and work gloves. Keep quenching cloth and fire extinguisher nearby when brazing. Use care in handling, rigging, and setting bulky equipment.

Read these instructions thoroughly and follow all warnings or cautions included in literature and attached to the unit. Consult local building codes and current editions of the National Electrical Code (NEC) NFPA 70. In Canada, refer to current editions of the Canadian electrical code CSA 22.1.

Recognize safety information. This is the safety-alert symbol . When you see this symbol on the unit and in instructions or manuals, be alert to the potential for personal injury. Understand these signal words: DANGER, WARNING, and CAUTION. These words are used with the safety-alert symbol. DANGER identifies the most serious hazards which **will** result in severe personal injury or death. WARNING signifies hazards which **could** result in personal injury or death. CAUTION is used to identify unsafe practices which **may** result in minor personal injury or product and property damage. NOTE is used to highlight suggestions which **will** result in enhanced installation, reliability, or operation.



WARNING

ELECTRICAL SHOCK HAZARD

Failure to follow this warning could result in personal injury or death.

Before installing, modifying, or servicing system, main electrical disconnect switch must be in the OFF position. There may be more than 1 disconnect switch. Lock out and tag switch with a suitable warning label.



CAUTION

EQUIPMENT DAMAGE HAZARD

Failure to follow this caution may result in equipment damage or improper operation.

Do not bury more than 36 in. (914 mm) of refrigerant pipe in the ground. If any section of pipe is buried, there must be a 6 in. (152 mm) vertical rise to the valve connections on the outdoor units. If more than the recommended length is buried, refrigerant may migrate to the cooler buried section during extended periods of system shutdown. This causes refrigerant slugging and could possibly damage the compressor at start-up.

GENERAL

These instructions cover the installation, start-up and servicing of outdoor and indoor units ductless systems.

SYSTEM REQUIREMENTS

Allow sufficient space for airflow and servicing unit. See Fig. 4 for minimum required distances between unit and walls or ceilings.

Piping

IMPORTANT: Both refrigerant lines must be insulated separately.

- Minimum refrigerant line length between the indoor and outdoor units is 10 ft. (3 m).
- The following maximum lengths are allowed.

Table 2— Maximum Lengths

System Size		9K (208-23 V)	12K (208-230 V)	18K (208-230 V)
Piping	Min. Piping Length	ft (m)	10 (3)	10 (3)
	Standard Piping Length	ft (m)	25 (7.6)	25 (7.6)
	Max. outdoor- indoor height difference	ft (m)	32.8 (9.9)	32.8 (9.9)
	Max. Piping Length with no additional refrigerant charge	ft (m)	25 (7.6)	25 (7.6)
	Max. Piping Length	ft (m)	82 (25)	82 (25)
	Additional refrigerant charge (between Standard – Max piping length)	Oz/ft (g/M)	0.2 (18.6)	0.2 (18.6)
	Gas Pipe (size - connection type)	in	1/4 flare connection	1/4 flare connection
	Liquid Pipe (size - connection type)	in	1/2 flare connection	1/2 flare connection
Refrigerant	Refrigerant Type		R410A	R410A
	Charge Amount	Lbs (kg)	3.1 (1.4)	3.1 (1.4)

* Charge is for piping that runs up to 25 ft. (7.6 m)

** For piping runs greater than 25 ft. (7.6 m), add specified amount of charge per foot of extra piping, up to the allowable length.

*** EXV - Electronic Expansion Device, Capillary tubes are used as metering devices

All wires must be sized per NEC (National Electrical Code) or CEC (Canadian Electrical Code) and local codes. Use Electrical Data table MCA (minimum circuit amps) and MOCP (maximum over current protection) to correctly size the wires and the disconnect fuse or breakers respectively.

Per caution note, only copper conductors with a minimum 300 volt rating and 2/64-inch thick insulation must be used. The use of BX cable is not recommended.

Recommended Connection Method for Power and Communication Wiring - Power and Communication Wiring:

The main power is supplied to the outdoor unit. The field supplied 14/3 power/communication wiring from the outdoor unit to indoor unit consists of four (4) wires and provides the power for the indoor unit. Two wires are high voltage AC power, one is communication wiring and the other is a ground wire.

Recommended Connection Method for Power and Communication Wiring (To minimize communication wiring interference)

Power Wiring:

The main power is supplied to the outdoor unit. The field supplied power wiring from the outdoor unit to indoor unit consists of three (3) wires and provides the power for the indoor unit. Two wires are high voltage AC power and one is a ground wire.

To minimize voltage drop, the factory recommended wire size is 14/2 stranded with a ground.

Communication Wiring:

A separate shielded copper conductor only, with a minimum 300 volt rating and 2/64-inch thick insulation, must be used as the communication wire from the outdoor unit to the indoor unit.

Please use a separate shielded 16GA stranded control wire.

CAUTION

EQUIPMENT DAMAGE HAZARD

Failure to follow this caution may result in equipment damage or improper operation.

- Wires should be sized based on NEC and local codes.
- Use copper conductors only with a minimum 300 volt rating and 2/64 inch thick insulation.

CAUTION

EQUIPMENT DAMAGE HAZARD

Failure to follow this caution may result in equipment damage or improper operation.

- Be sure to comply with local codes while running wire from indoor unit to outdoor unit.
- Every wire must be connected firmly. Loose wiring may cause terminal to overheat or result in unit malfunction. A fire hazard may also exist. Therefore, be sure all wiring is tightly connected.
- No wire should be allowed to touch refrigerant tubing, compressor or any moving parts.
- Disconnecting means must be provided and shall be located within sight and readily accessible from the air conditioner.
- Connecting cable with conduit shall be routed through hole in the conduit panel.

Table 3—Electrical Data

UNIT SIZE	OPERVOLTAGE- MAX / MIN*	COMPRESSOR			OUTDOOR FAN				INDOOR FAN				MCA	MAX FUSE CB AMP
		V/PH/HZ	RLA	LRA	V/PH/HZ	FLA	HP	W	V/PH/HZ	FLA	HP	W		
9K	253 / 187	208-230/1/60	8.5	35	208-230/1/60	0.37	0.04	30	208-230/1/60	0.1	0.027	20	12	15
12K			9.5	40		0.37	0.04	30		0.1	0.027	20	13	20
18K			14.5	30		0.48	0.12	90		0.1	0.027	20	19	30

DIMENSIONS - INDOOR

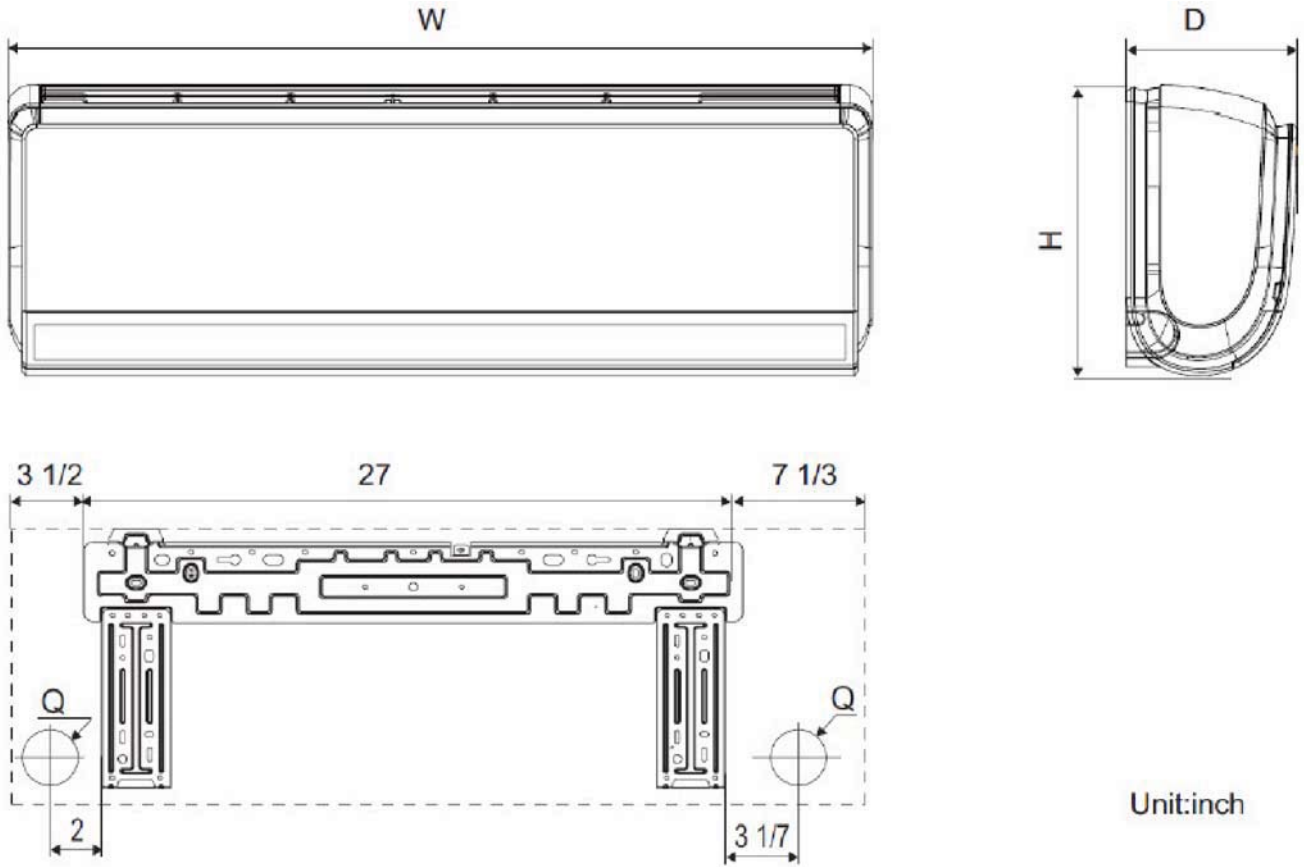

Fig. 1 - Indoor Unit Dimensions

Table 4—Indoor Unit Dimensions

Model	W	H	D	Q
09/12K	37 4/5	12 3/5	8	Φ 2 1/6
18K	37 4/5	12 3/5	8	Φ 2 3/4

DIMENSIONS - OUTDOOR

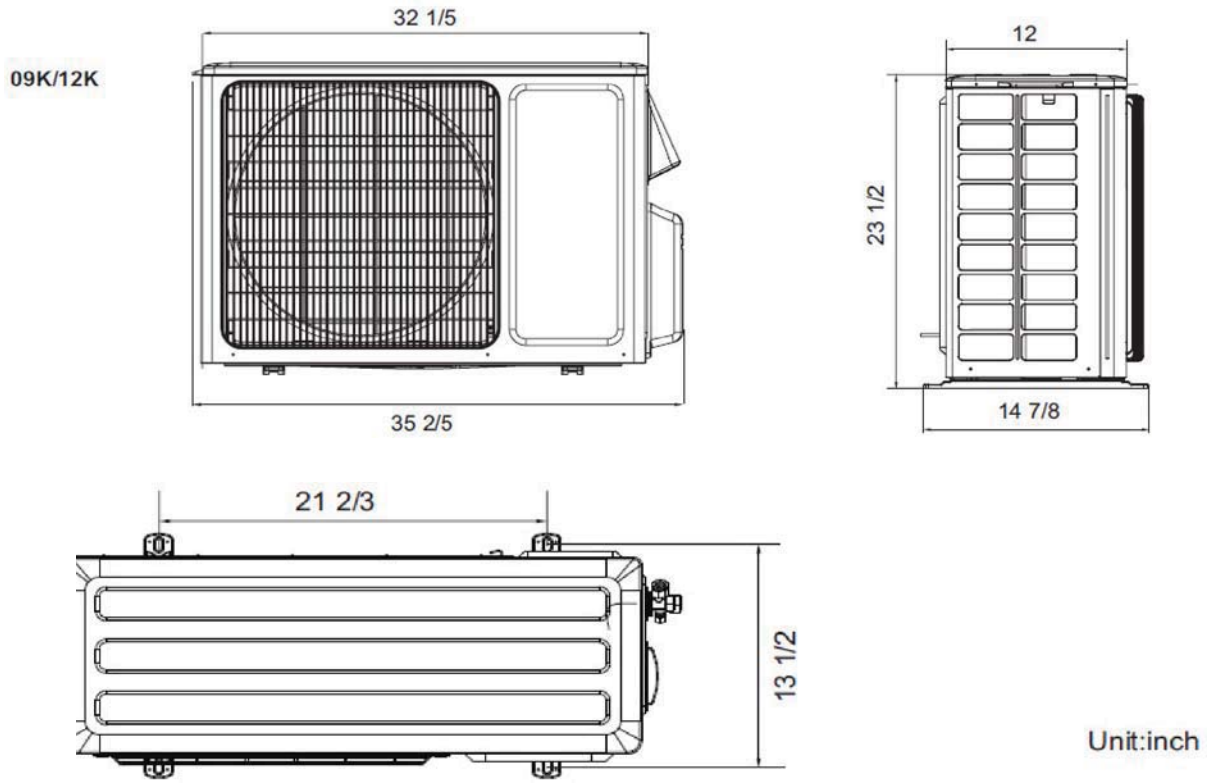

Fig. 2 - Outdoor Unit (Sizes 9 and 12)

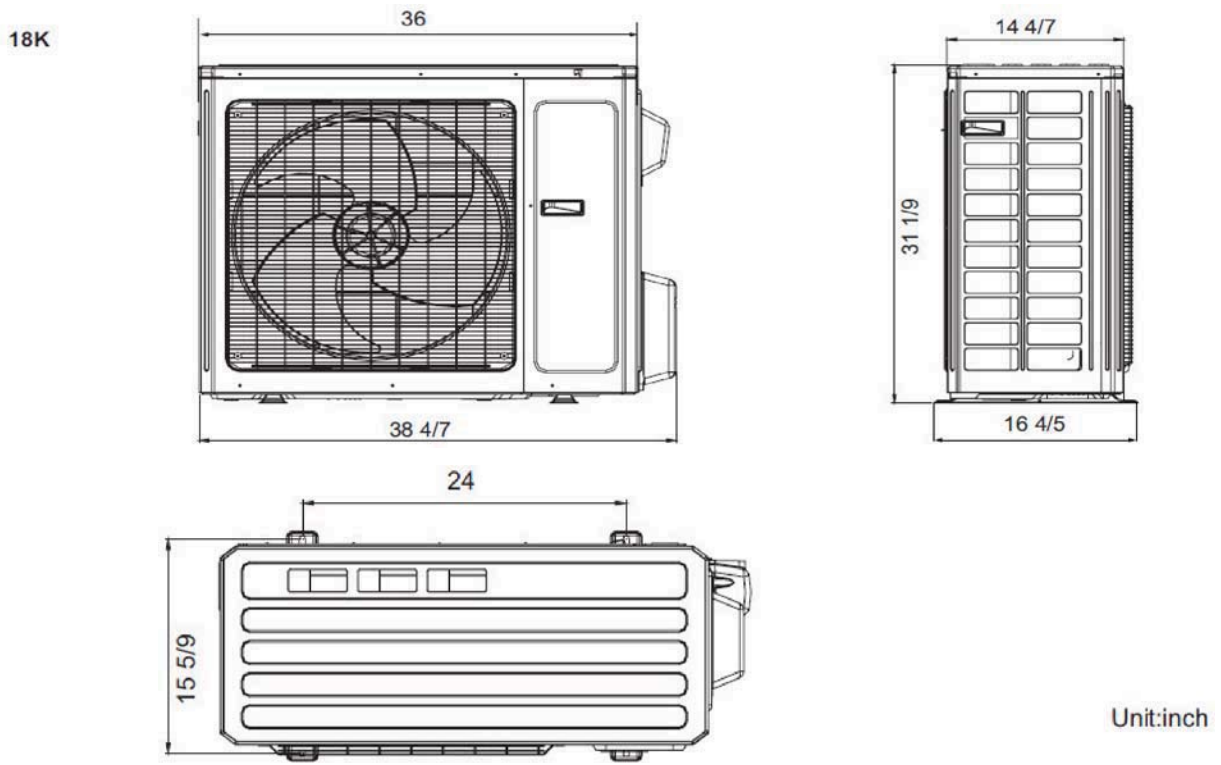

Fig. 3 - Outdoor Unit (Size 18)

CLEARANCES - INDOOR

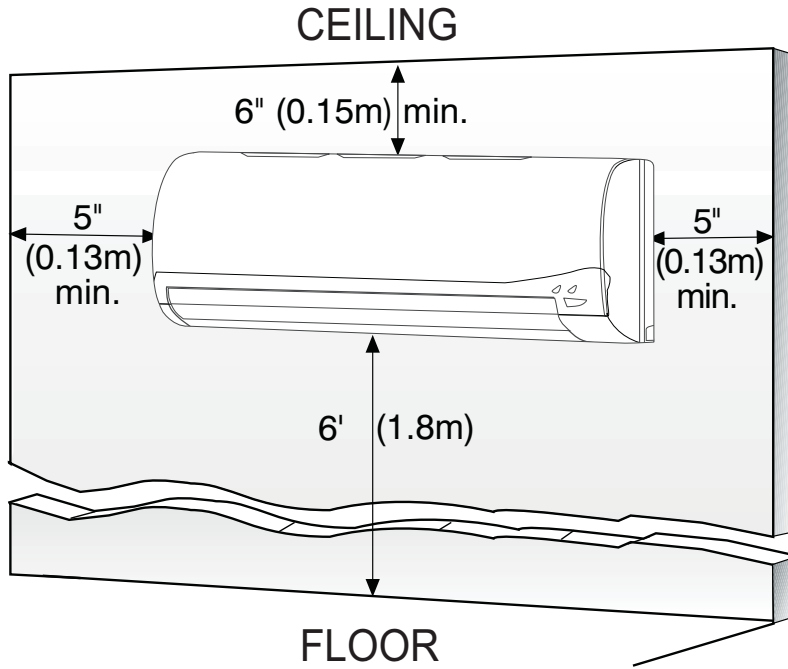

Fig. 4 - Indoor Unit Clearances

CLEARANCES - OUTDOOR

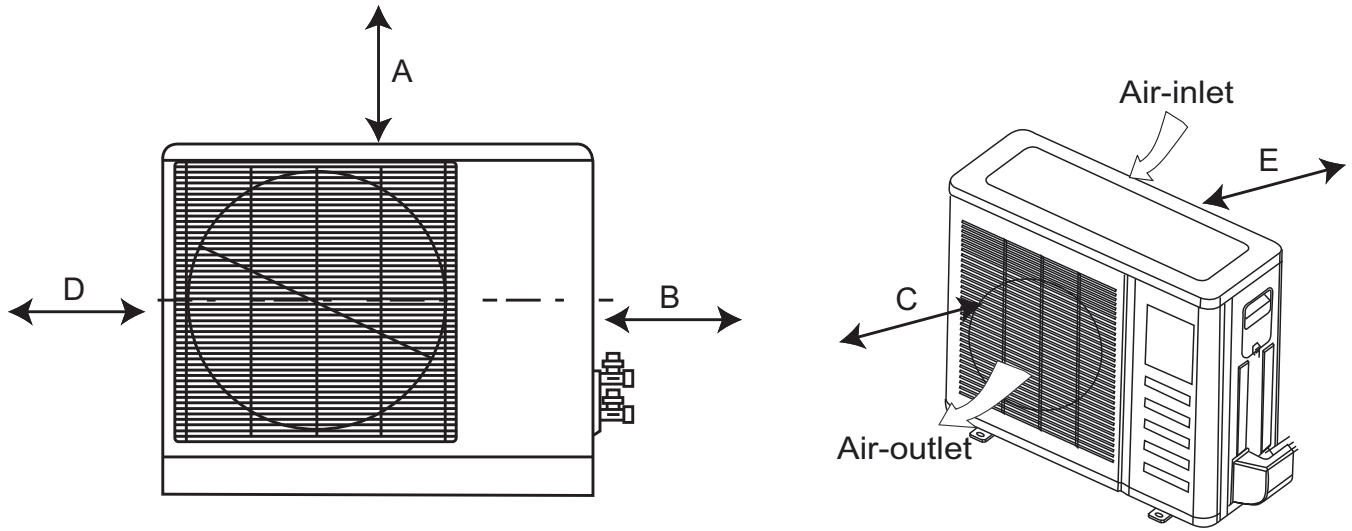

Fig. 5 - Outdoor Unit Clearances

Table 5—Outdoor Clearances

UNIT	Minimum Value in. (mm)
A	24 (609)
B	24 (609)
C	24 (609)
D	4 (101)
E	4 (101)

INSTALLATION GUIDE

Ideal installation locations include:

Indoor Unit

- A location where there are no obstacles near inlet and outlet area.
- A location which can bear the weight of indoor unit.
- Do not install indoor units near a direct source of heat such as direct sunlight or a heating appliance.
- A location which provides appropriate clearances as outlined in Fig. 4. Be sure to leave enough distance to allow access for routine maintenance. The installation site should be 72" or more above the floor.
- Select a place away from potential electronic interference.
- Select a place where the filter can be easily removed.

Outdoor Unit

- A location which is convenient to installation and not exposed to strong wind.
- A location which can bear the weight of outdoor unit and where the outdoor unit can be mounted in a level position.
- A location which provides appropriate clearances as outlined in Fig. 4.
- Do not install the indoor or outdoor units in a location with special environmental conditions.
- Make sure the outdoor unit is installed in accordance with the installation instructions and is convenient for maintenance and repair.
- See the refrigerant piping table for the maximum height difference between indoor and outdoor units and the maximum length of the connecting tubing.

INDOOR UNIT INSTALLATION

INSTALL MOUNTING PLATE

1. Carefully remove the mounting plate from the unit box.
2. The mounting plate should be located horizontally and level on the wall. All minimum spacings shown in Fig. 6.
3. If the wall is block, brick, concrete or similar material, drill .2" (5 mm) diameter holes and insert anchors for the appropriate mounting screws.
4. Attach the mounting plate to the wall.

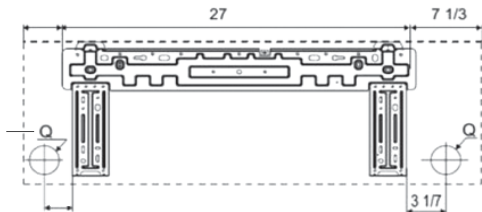

Fig. 6 - 09 and 12K Mounting Plate Spacing

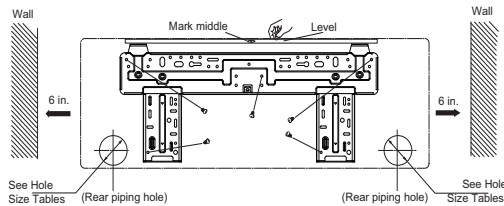

Fig. 7 - 18K Mounting Plate Spacing

DRILL HOLE IN WALL FOR INTERCONNECTING PIPING, DRAIN AND WIRING

Refrigerant Line Routing

The refrigerant lines may be routed in any of the four directions shown in Fig. 8.

For maximum serviceability, it is recommended to have refrigerant line flare connections and the drain connection on the outside of the wall that the fan coil is mounted on.

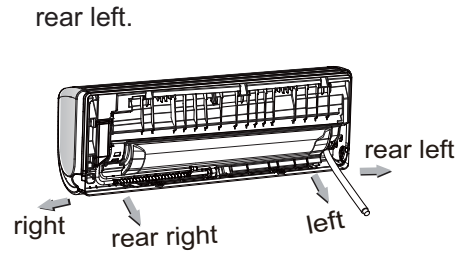

Fig. 8 - Refrigerant Line Routing

A12585

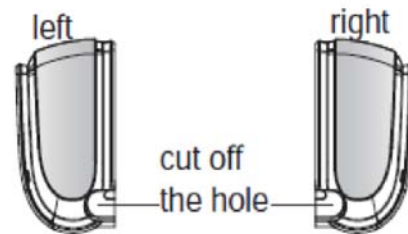

Fig. 9 - Refrigerant Line Routing

If piping is going through the back:

1. Determine pipe hole position using the mounting plate as a template. Drill pipe hole diameter per chart below. The outside pipe hole is 1/2-in. (13 mm) min. lower than inside pipe hole, so it slants slightly downward. If piping is going to exit from the left rear, it is recommended to field-fabricate piping extensions to get the flare connections to the outside of the wall.

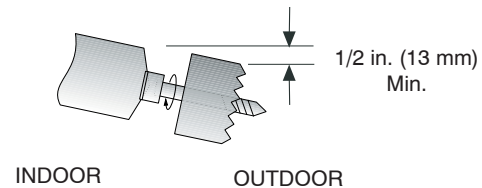

Fig. 10 - Drill Holes

A07371

Table 6—Hole Diameter

Model Size	Hole Diameter in. (mm)
9k, 12k and 18k	2.2 (56)

If piping is going through the right or left side:

1. Use a small saw blade to carefully remove the corresponding plastic covering on side panel and drill the appropriate size hole where the pipe is going through the wall. See Fig. 16.
2. Remove knockout (see Fig. 8).

NOTE: If required, a condensate pump is available for the application.

OUTDOOR UNIT INSTALLATION

1. Use a rigid base to support unit in a level position.
2. Locate outdoor unit and connect piping and wiring.

⚠ CAUTION

EQUIPMENT DAMAGE HAZARD

Failure to follow this caution may result in equipment damage or improper operation.

Excessive torque can break flare nut depending on installation conditions.

Piping Connections to Outdoor Unit

IMPORTANT: Use refrigeration grade tubing **ONLY**. No other type of tubing may be used. Use of other types of tubing will void manufacturer's warranty. Make sure there is enough piping to cover the required length between the outdoor and indoor unit. Only use piping suitable for high side pressure for both high side and low side connections.

Piping Guide:

- Do not open service valves or remove protective caps from tubing ends until all the connections are made.
 - Bend tubing with bending tools to avoid kinks and flat spots.
 - Keep the tubing free of dirt, sand, moisture, and other contaminants to avoid damaging the refrigerant system.
 - Avoid sags in the suction line to prevent the formation of oil traps. Insulate each tube with minimum 3/8-in. (10 mm) wall thermal pipe insulation. Inserting the tubing into the insulation before making the connections saves time and improves installation quality.
1. Remove service valve cover if provided with unit.
 2. Cut tubing with tubing cutter.
 3. Install correct size flare nut onto tubing and make flare connection.
 4. Apply a small amount of refrigerant oil to the flare connection on the tubing.
 5. Properly align tubing in with service valve.
 6. Tighten flare nut and finish installation using two wrenches as shown in Fig. 11.

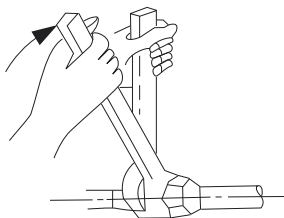

A07354

Fig. 11 - Tighten Flare Nut

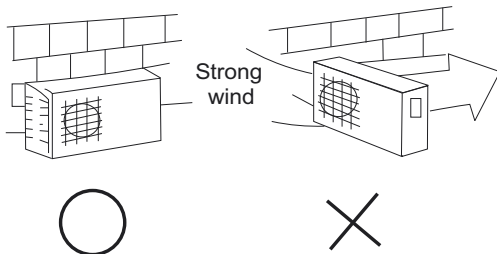

A07350

Fig. 12 - High Wind Installation

Outdoor Unit Wiring Connections

1. Mount outdoor power disconnect.
2. Run power wiring from main box to disconnect per NEC and local codes. Set outdoor unit in place.
3. Remove field wiring cover from unit by removing screws.
4. Connect conduit to the conduit panel. (See Fig. 13)
5. Properly connect both power supply and control lines to terminal block per the connection diagram.
6. Ground unit in accordance with NEC and local electrical codes.
7. Use lock nuts to secure conduit.
8. Reinstall field wiring cover.

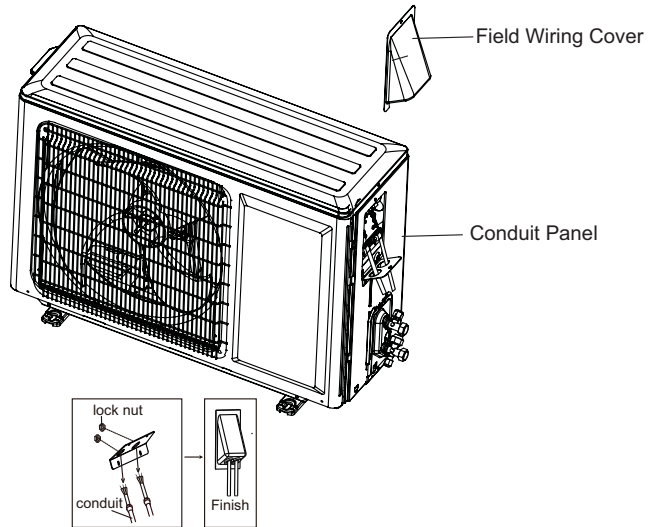

Fig. 13 - Field Wiring

A12539

⚠ CAUTION

EQUIPMENT DAMAGE HAZARD

Failure to follow this caution may result in equipment damage or improper operation.

- Be sure to comply with local codes while running wire from indoor unit to outdoor unit.
- Every wire must be connected firmly. Loose wiring may cause terminal to overheat or result in unit malfunction. A fire hazard may also exist. Therefore, be sure all wiring is tightly connected.
- No wire should be allowed to touch refrigerant tubing, compressor or any moving parts.
- Disconnecting means must be provided and shall be located within sight and readily accessible from the air conditioner.
- Connecting cable with conduit shall be routed through hole in the conduit panel.

INSTALL ALL POWER, INTERCONNECTING WIRING, AND PIPING TO INDOOR UNIT

1. Run interconnecting piping and wiring from outdoor unit to indoor unit.
2. Pass interconnecting cable through hole in wall (outside to inside).
3. Lift indoor unit into position and route piping and drain through hole in wall (inside to outside). Fit interconnecting wiring into back side of indoor unit.
4. Hang indoor unit on upper hooks of wall mounting plate (as shown in Fig. 14 and Fig. 17).

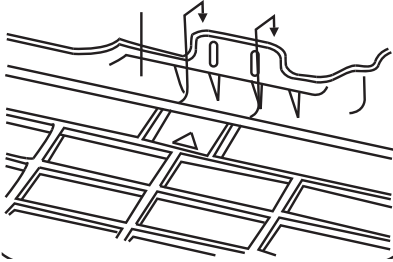

Fig. 14 - Hanging Indoor Unit

A08283

5. Open front cover of indoor unit and remove field wiring terminal block cover (see Fig. 15).

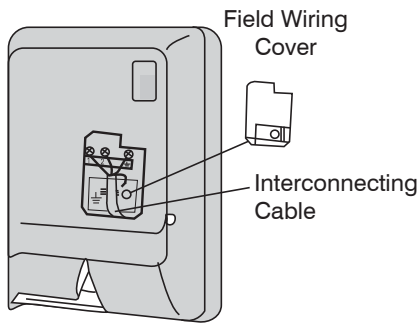

Fig. 15 - Field Wiring Cover

A08279

6. Pull interconnecting wire up from back of indoor unit and position in close to the terminal block on indoor unit.
7. Push bottom of indoor unit onto mounting plate to complete wall mount.
8. Connect wiring from outdoor unit per connection diagram (see Fig. 23).

NOTE: Polarity of power wires must match original connection on outdoor unit.

9. Replace field wiring cover and close front cover of indoor unit.
10. Connect refrigerant piping and drain line outside of indoor unit. Refer to Fig. 11 for proper installation of flare connections. Complete pipe insulation at flare connection then fasten piping and wiring to the wall as required. Completely seal the hole in the wall.

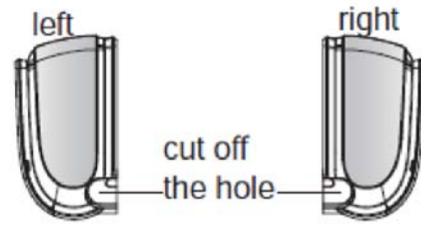

Fig. 16 - Remove Knockouts

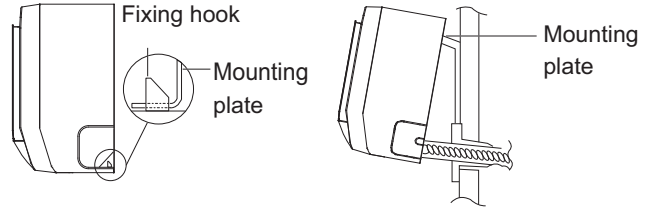

Fig. 17 - Hang Indoor Unit

A12408

⚠ CAUTION

UNIT DAMAGE HAZARD

Failure to follow this caution may result in equipment damage or improper operation.

Never use the system compressor as a vacuum pump.

Refrigerant tubes and indoor coil should be evacuated using the recommended deep vacuum method of 500 microns. The alternate triple evacuation method may be used if the procedure outlined below is followed. Always break a vacuum with dry nitrogen.

SYSTEM VACUUM AND CHARGE

Using Vacuum Pump

1. Completely tighten flare nuts A, B, C, D, connect manifold gage charge hose to a charge port of the low side service valve. (See Fig. 18.)
2. Connect charge hose to vacuum pump.
3. Fully open the low side of manifold gage. (See Fig. 19)
4. Start vacuum pump
5. Evacuate using either deep vacuum or triple evacuation method.
6. After evacuation is complete, fully close the low side of manifold gage and stop operation of vacuum pump.
7. The factory charge contained in the outdoor unit is good for up to 25 ft. (8 m) of line length. For refrigerant lines longer than 25 ft (8 m), add 0.2 oz. per foot of extra piping up to the maximum allowable length.
8. Disconnect charge hose from charge connection of the low side service valve.
9. Fully open service valves B and A.
10. Securely tighten caps of service valves.

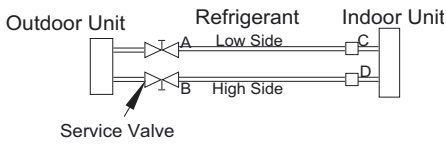

Fig. 18 - Service Valve

A07360

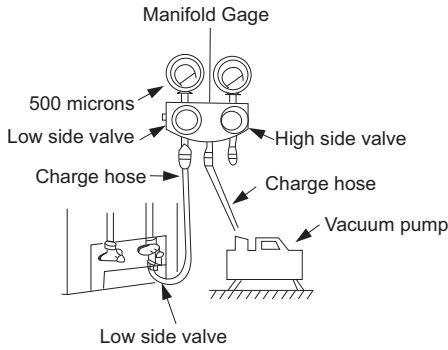

Fig. 19 - Manifold

A07361

Deep Vacuum Method

The deep vacuum method requires a vacuum pump capable of pulling a vacuum of 500 microns and a vacuum gage capable of accurately measuring this vacuum depth. The deep vacuum method is the most positive way of assuring a system is free of air and liquid water. (See Fig. 20)

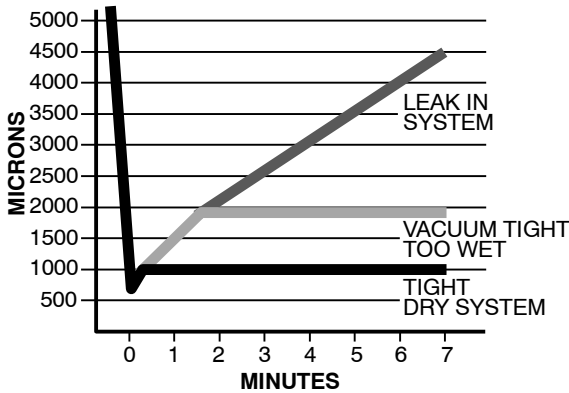

Fig. 20 - Deep Vacuum Graph

A95424

Triple Evacuation Method

The triple evacuation method should only be used when vacuum pump is only capable of pumping down to 28 in. of mercury vacuum and system does not contain any liquid water.

Refer to Fig. 21 and proceed as follows:

1. Pump system down to 28 in. of mercury and allow pump to continue operating for an additional 15 minutes.
2. Close service valves and shut off vacuum pump.
3. Connect a nitrogen cylinder and regulator to system and open until system pressure is 2 psig.
4. Close service valve and allow system to stand for 1 hr. During this time, dry nitrogen will be able to diffuse throughout the system absorbing moisture.
5. Repeat this procedure as indicated in Fig. 21. The system is then free of any contaminants and water vapor.

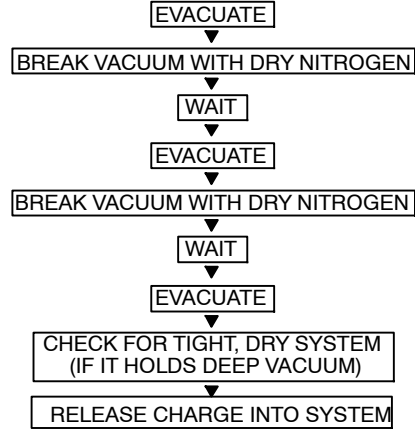

Fig. 21 - Triple Evacuation Method

A95425

Final Tubing Check

IMPORTANT: Check to be certain factory tubing on both indoor and outdoor unit has not shifted during shipment. Ensure tubes are not rubbing against each other or any sheet metal. Pay close attention to feeder tubes, making sure wire ties on feeder tubes are secure and tight.

START-UP

Test Operation

Perform test operation after completing gas leak and electrical safety check.

1. Push the "ON/OFF" button on Remote Control to begin testing.

NOTE: A protection feature prevents the air conditioner from being activated for approximately 3 minutes.

2. Push MODE button, select COOLING, HEATING, FAN mode to check if all functions work correctly.

SYSTEM CHECKS

1. Conceal the tubing where possible.
2. Make sure that the drain tube slopes downward along its entire length.
3. Ensure all tubing and connections are properly insulated.
4. Fasten tubes to the outside wall, when possible.
5. Seal the hole through which the cables and tubing pass.

INDOOR UNIT

1. Do all Remote Control buttons function properly?
2. Do the display panel lights work properly?
3. Does the air deflection louver function properly?
4. Does the drain work?

OUTDOOR UNIT

1. Are there unusual noises or vibrations during operation?

Explain Following Items To Customer With The Aid Of The Owner's Manual:

1. How to turn air conditioner on and off; selecting COOLING, HEATING and other operating modes; setting a desired temperature; setting the timer to automatically start and stop air conditioner operation; and all other features of the Remote Control and display panel.
2. How to remove and clean the air filter.
3. How to set air deflection louver.
4. Explain care and maintenance.
5. Present the Owner's Manual and installation instructions to customer.

INSTALLATION AND MAINTENANCE OF FILTER

1. Grasp the front panel by its two ends and lift the panel and then remove the air filter.
2. Install a clean air filter along the arrow direction and close the panel.

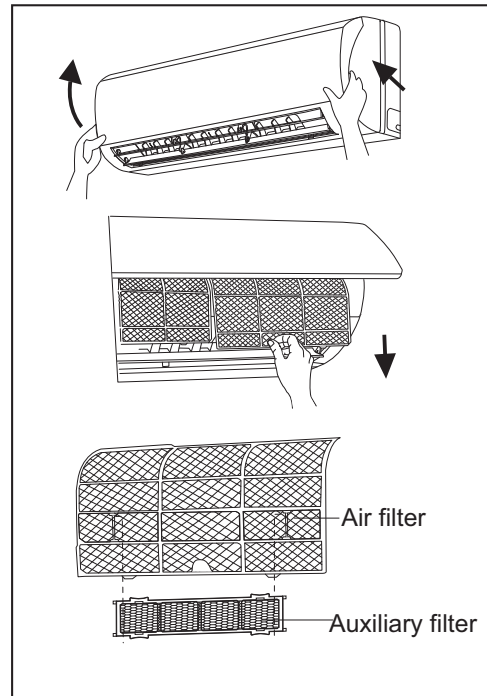

A12541

Fig. 22 - Install Air Filter

WIRING DIAGRAMS

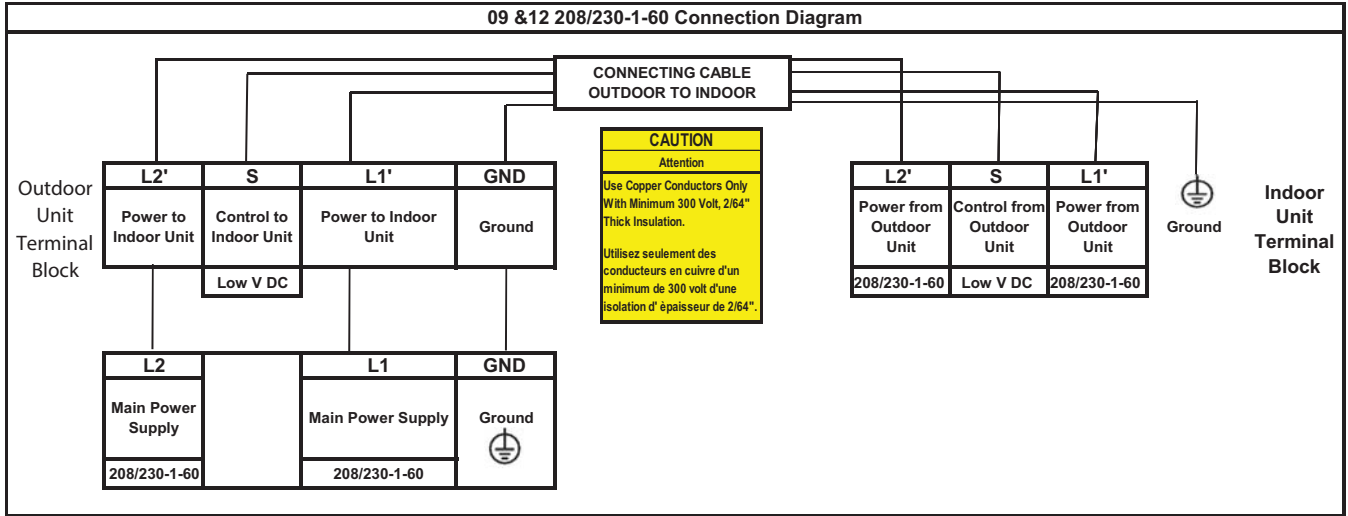

Fig. 23 - 09K & 12K Unit Wiring Diagrams

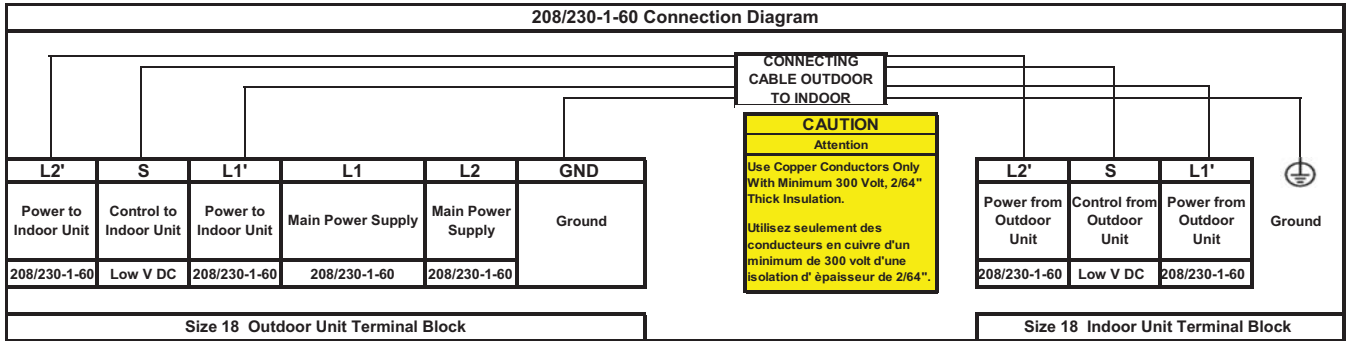

Fig. 24 - 18K Unit Wiring Diagrams

NOTE: Polarity of power wires must match original connection on outdoor unit.

TROUBLESHOOTING

This unit has on-board diagnostics. Error codes appear on the LED display on the front panel of the indoor unit in place of the temperature display. Error codes are also displayed on the outdoor unit microprocessor board with colored LED lights. The table below explains the error codes for both units.

Table 7—Diagnostic Codes

Display table for error status		
Error name	Error definition	Error code display
Freon recovery mode	Operation status is displayed immediately	Fo
Malfunction of indoor fan	Malfunction of hardware	H6
Malfunction of middle temperature sensor of indoor evaporator	Malfunction of hardware	F2
Malfunction of indoor ambient temperature sensor	Malfunction of hardware	F1
Communication malfunction between indoor unit and outdoor unit	Malfunction of hardware	E6
Malfunction of jumper cap	Malfunction of hardware	C5
Limit/decrease frequency due to module current protection	Display through adjustment with remote controller	En
Limit/decrease frequency due to module temperature protection	Display through adjustment with remote controller	EU
Limit/decrease frequency due to overload protection	Display through adjustment with remote controller	F6
Limit/decrease frequency due to freeze prevention protection	Display through adjustment with remote controller	FH
Limit/decrease frequency due to discharge protection	Display through adjustment with remote controller	F9
Limit/decrease frequency due to AC current protection of outdoor unit	Display through adjustment with remote controller	F8
Malfunction overload temperature sensor	Malfunction of hardware	FE
Malfunction of outdoor discharge temperature	Malfunction of hardware	F5
Malfunction of outdoor ambient temperature sensor	Malfunction of hardware	F3
Malfunction of outdoor condenser temperature sensor	Malfunction of hardware	F4
Circuit malfunction of module temperature sensor	Malfunction of hardware	P7
Overload protection of compressor	Other malfunction	H3
Discharge protection	Other malfunction	E4
Overload protection	Other malfunction	E8
AC current protection of outdoor unit	Other malfunction	E5
Module current protection	Other malfunction	H5
Module temperature protection	Other malfunction	P8
Freeze prevention protection	Other malfunction	E2
High power protection	Other malfunction	L9
Lacking/inverse phase protection of compressor	Other malfunction	U2
PFC current malfunction	Other malfunction	HC
High DC bus bar voltage protection	Other malfunction	PH
Low DC bus bar voltage protection	Other malfunction	PL
Freon-lacking protection	Other malfunction	FO
Mode shock	Malfunction of hardware	E7
Non-matching between indoor unit and outdoor unit	Malfunction of hardware	LP
Read-write malfunction of memory chip	Malfunction of hardware	EE
Abnormal changeover for 4-way valve	Malfunction of hardware	U7
Malfunction of outdoor fan 2	Malfunction of hardware	LA
Malfunction of outdoor fan 1	Malfunction of hardware	L3
Low pressure protection	Other malfunction	E3
High pressure protection	Other malfunction	E1
Drop malfunction of DC bus bar voltage	Other malfunction	U3
Current detection malfunction for the complete unit	Malfunction of hardware	U5
Charing malfunction for capacity	Malfunction of hardware	PU
Phase current detection malfunction of compressor	Malfunction of hardware	U1
De synchronizing of compressor	Other malfunction	H7
Demagnetizing protection of compressor	Other malfunction	HE
Failure start up of compressor	Other malfunction	Lc
High peak current of compressor	Other malfunction	P5
Conglutination malfunction of relay of refrigerant electric heater of OU	Malfunction of hardware	A2
Refrigerator heater of outdoor unit is invalid	Display through adjustment with remote controller	A3
Malfunction of temperature sensor of refrigerant heater	Malfunction of hardware	A4
Malfunction exit tube temperature sensor for condenser	Malfunction of hardware	A5
Oil return	Display through adjustment with remote controller	F7
Nominal cooling and heating (capacity test code)	Operation status is displayed immediately	P1
Maximum cooling and heating (capacity test code)	Operation status is displayed immediately	P2
Medium cooling and heating (capacity test code)	Operation status is displayed immediately	P3
Minimum cooling and heating (capacity test code)	Operation status is displayed immediately	PO

