

Visit [www.carrier.com](http://www.carrier.com)

## Installation and Start-Up Instructions

**NOTE:** Read the entire instruction manual before starting the installation.

This symbol → indicates a change since the last issue.

### SAFETY CONSIDERATIONS

Improper installation, adjustment, alteration, service, maintenance, or use can cause explosion, fire, electrical shock, or other conditions which may cause death, personal injury, or property damage. Consult a qualified installer, service agency, or your distributor or branch for information or assistance. The qualified installer or agency must use factory-authorized kits or accessories when modifying this product. Refer to the individual instructions packaged with the kits or accessories when installing.

Follow all safety codes. Wear safety glasses, protective clothing, and work gloves. Use quenching cloth for brazing operations. Have fire extinguisher available. Read these instructions thoroughly and follow all warnings or cautions included in literature and attached to the unit. Consult local building codes and National Electrical Code (NEC) for special requirements.

Recognize safety information. This is the safety-alert symbol ⚠. When you see this symbol on the unit and in instructions or manuals, be alert to the potential for personal injury.

Understand the signal words DANGER, WARNING, and CAUTION. These words are used with the safety-alert symbol. DANGER identifies the most serious hazards which **will** result in severe personal injury or death. WARNING signifies hazards which **could** result in personal injury or death. CAUTION is used to identify unsafe practices which **would** result in minor personal injury or product and property damage. NOTE is used to highlight suggestions which **will** result in enhanced installation, reliability, or operation.

#### ⚠ WARNING

##### ELECTRICAL SHOCK HAZARD

Failure to follow this warning could cause death or personal injury.

Before installing, modifying, or servicing system, main electrical disconnect switch must be in the OFF position. There may be more than 1 disconnect switch. Lock out and tag switch with a suitable warning label.

#### ⚠ WARNING

##### EXPLOSION HAZARD

Failure to follow this warning could result in death or personal injury.

Puron systems operate at higher pressures than standard R-22 systems. Be certain that service equipment is rated for Puron. Some R-22 service equipment may not be acceptable. Check with your distributor.

### INSTALLATION RECOMMENDATIONS

**NOTE:** In some cases noise in the living area has been traced to gas pulsations from improper installation of equipment.

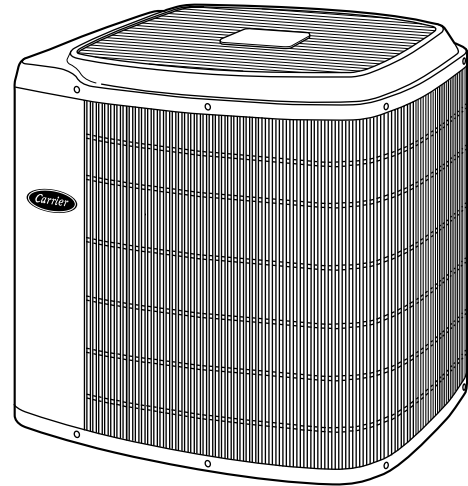

A98516

**Fig. 1—Model 38YSP**

1. Locate unit away from windows, patios, decks, etc. where unit operation sound may disturb customer.
2. Ensure that vapor and liquid tube diameters are appropriate to capacity of unit.
3. Run refrigerant tubes as directly as possible by avoiding unnecessary turns and bends.
4. Leave some slack between structure and unit to absorb vibration.
5. When passing refrigerant tubes through the wall, seal opening with RTV or other pliable silicon-based caulk. (See Fig. 2.)
6. Avoid direct tubing contact with water pipes, duct work, floor joists, wall studs, floors, and walls.
7. Do not suspend refrigerant tubing from joists and studs with a rigid wire or strap which comes in direct contact with tubing. (See Fig. 2.)
8. Ensure that tubing insulation is pliable and completely surrounds vapor tube.
9. When necessary, use hanger straps which are 1 in. wide and conform to shape of tubing insulation. (See Fig. 2.)
10. Isolate hanger straps from insulation by using metal sleeves bent to conform to shape of insulation.

When outdoor unit is connected to factory-approved indoor unit, outdoor unit contains system refrigerant charge for operation with indoor unit of same size when connected by 15 ft of field-supplied or factory accessory tubing. For proper unit operation, check refrigerant charge using charging information located on control box cover and/or in the Check Charge section of this instruction.

**IMPORTANT:** Maximum liquid-line size is 3/8-in. OD for all residential applications including long line.

Manufacturer reserves the right to discontinue, or change at any time, specifications or designs without notice and without incurring obligations.

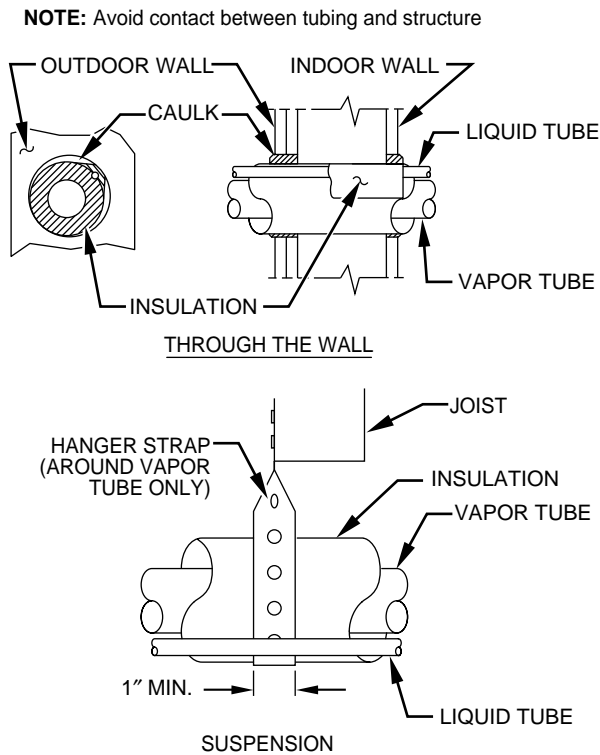

**Fig. 2—Connecting Tubing Installation**

A94028

**IMPORTANT:** Always install the factory-supplied Puron heat pump (bi-flow) liquid-line filter drier. If replacing the filter drier, refer to Product Data Digest for appropriate part number. Obtain replacement filter driers from your distributor or branch.

**INSTALLATION**

**IMPORTANT:** Specifications for this unit in residential new construction market require the outdoor unit, indoor unit, refrigerant tubing sets, metering device, and filter drier listed in presale literature. There can be no deviation. Consult the Application Guideline and Service Manual for Residential Split-System Air Conditioners and Heat Pumps using Puron Refrigerant to obtain required unit changes for specific applications and for R-22 retrofit.

**Step 1—Check Equipment and Job Site**

**UNPACK UNIT**

Move to final location. Remove carton taking care not to damage unit.

**INSPECT EQUIPMENT**

File claim with shipping company prior to installation if shipment is damaged or incomplete. Locate unit rating plate on unit corner panel. It contains information needed to properly install unit. Check rating plate to be sure unit matches job specifications.

**Step 2—Install on a Solid, Level Mounting Pad**

If conditions or local codes require the unit be attached to pad, tie down bolts should be used and fastened through knockouts provided in unit base pan. Refer to unit mounting pattern in Fig. 3 to determine base pan size and knockout hole location.

On rooftop applications, mount on level platform or frame. Place unit above a load-bearing wall and isolate unit and tubing set from

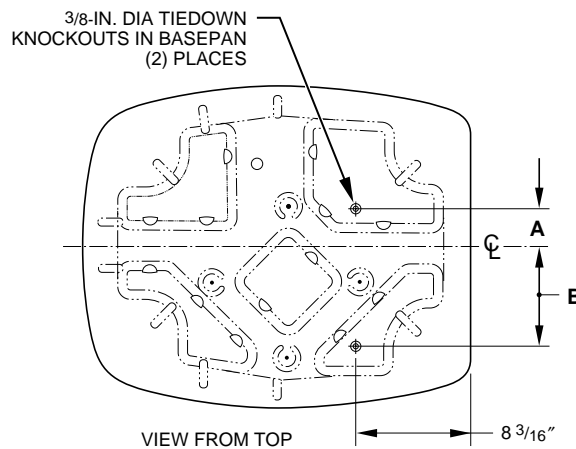

**Dimensions (In.)**

A97548

UNIT SIZE	MINIMUM MOUNTING PAD DIMENSIONS		TIEDOWN KNOCKOUT LOCATIONS	
	Support Feet	Snow Stand	A	B
<b>024-042</b>	26 X 32	31 X 35	4	9-3/4
<b>048, 060</b>	34 X 42	36 X 46	5-5/16	11-13/16

**Fig. 3—Mounting Unit to Pad**

structure. Arrange supporting members to adequately support unit and minimize transmission of vibration to building. Consult local codes governing rooftop applications.

**⚠ CAUTION**

**PROPERTY DAMAGE HAZARD**  
 Failure to follow this caution may result in property damage. Do not allow POE lubricant to come into contact with roofing material. POE may deteriorate certain types of synthetic roofing.

Roof mounted units exposed to winds above 5 mph may require wind baffles. Consult the Application Guideline and Service Manual for Residential Split-System Air Conditioners and Heat Pumps using Puron Refrigerant for wind baffle construction.

**NOTE:** Unit must be level to within  $\pm 2^\circ$  ( $\pm 3/8$  in./ft) per compressor manufacturer specifications.

**Step 3—Clearance Requirements**

When installing, allow sufficient space for airflow clearance, wiring, refrigerant piping, and service. Allow 30-in. clearance to service end of unit and 48 in. above unit. For proper airflow, a 6-in. clearance on 1 side of unit and 12 in. on all remaining sides must be maintained. Maintain a distance of 24 in. between units. Position so water, snow, or ice from roof or eaves cannot fall directly on unit.

On rooftop applications, locate unit at least 6 in. above roof surface.

**Step 4—Operating Ambient**

The minimum outdoor operating ambient in cooling mode is 55°F, and the maximum outdoor operating ambient in cooling mode is 125°F. The maximum outdoor operating ambient in heating mode is 66°F.

## Step 5—Elevate Unit

### ⚠ CAUTION

#### UNIT DAMAGE HAZARD

Failure to follow this caution may result in unit component damage.

Accumulation of water and ice in base pan may cause unit damage.

Elevate unit per local climate and code requirements to provide clearance above estimated snowfall level and ensure adequate drainage of unit. Fig. 4 shows unit with accessory support feet installed. Use accessory snow stand in areas where prolonged freezing temperatures are encountered. Refer to Installation Instructions packaged with accessories.

## Step 6—Check Expansion Device

### ⚠ CAUTION

#### UNIT DAMAGE HAZARD

Failure to follow this caution may result in unit component damage.

For proper unit operation and reliability, units must be installed with hard shutoff TXV specifically designed to operate with Puron. Do not use an R-22 TXV. Do not install with evaporator coils having capillary tube metering devices or pistons.

For TXV kit part number and charging instructions, refer to TXV label in outdoor unit.

## FURNACE COILS

If indoor unit (furnace coil) comes factory equipped with a bi-flow hard shutoff TXV specifically designed for Puron, no TXV change is required.

If TXV installation is required, remove existing Accu-Rater® from indoor coil. Refer to Fig. 5 and 6 and install TXV kit (specifically designed for Puron) as follows:

1. Install suction tube adapter.
2. Install liquid flare-to-sweat adapter.
3. Connect external equalizer tube to fitting on suction tube adapter.
4. Position sensing bulb on horizontal portion of suction tube adapter. Secure using supplied hardware.
5. Insulate bulb after installation. (See Fig. 6.)
6. Leak check all connections.

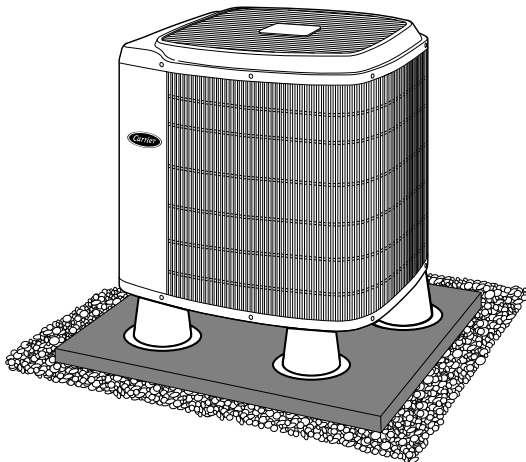

Fig. 4—Accessory Support Feet

A98533

## FAN COILS

If indoor unit (fan coil) comes factory equipped with a bi-flow hard shutoff TXV specifically designed for Puron, no TXV change is required.

If TXV installation is required, refer to TXV kit Installation Instructions for details on TXV installation.

## OUTDOOR TXV ON 024 SIZE

### ⚠ CAUTION

#### UNIT DAMAGE HAZARD

Failure to follow this caution may result in unit component damage.

Due to system design, this unit must be installed with a factory-listed indoor section. Non-approved coils could cause performance and reliability problems. Refer to presale literature for approved indoor sections.

The 024 size outdoor section is factory equipped with a TXV for metering refrigerant during heating mode. This heat pump must be matched with an approved indoor fan coil equipped with a hard shutoff TXV. See Product Data literature for approved indoor units.

## Step 7—Check Defrost Thermostat

Check defrost thermostat to ensure it is properly located and securely attached. There is a liquid header with a brass distributor and feeder tube going into outdoor coil. At the end of 1 of the feeder tubes, there is a 3/8-in. OD stub tube approximately 3 in. long. (See Fig. 7.) The defrost thermostat should be located on stub tube. Note that there is only 1 stub tube used with liquid header, and on most units it is the bottom circuit.

## Step 8—In Long-Line Applications, Install Liquid-Line Solenoid Valve (LSV)

For refrigerant piping arrangements with equivalent lengths greater than 50 ft and/or when elevation difference between indoor and outdoor unit is greater than  $\pm 20$  ft, follow all requirements of the Long-Line Guideline section in the Application Guideline and Service Manual for Residential Split-System Air Conditioners and Heat Pumps Using Puron Refrigerant.

If required by Long-Line Application Guideline, install LSV kit Part No. KHALS0401LLS specifically designed for Puron Heat Pump. LSV should be installed within 2 ft of outdoor unit with flow arrow pointing toward outdoor unit. Follow the Installation Instructions included with accessory kit.

**IMPORTANT:** Flow arrow must point toward outdoor unit.

## Step 9—Make Piping Connections

### ⚠ WARNING

#### EXPLOSION HAZARD

Failure to follow this warning could result in death or personal injury.

Relieve pressure and recover all refrigerant before system repair or final unit disposal. Use all service ports and open all flow-control devices, including solenoid valves.

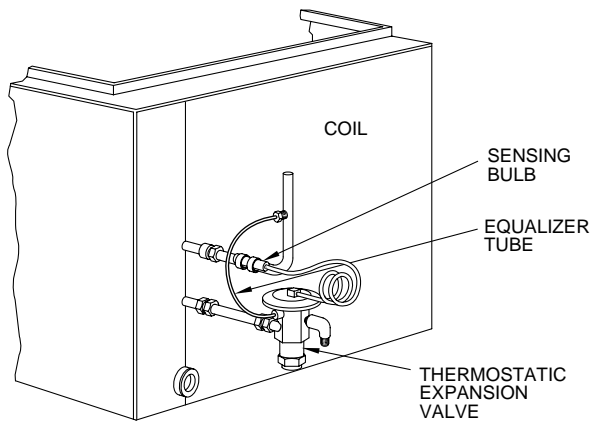

**Fig. 5—Typical TXV Installation**

A91277

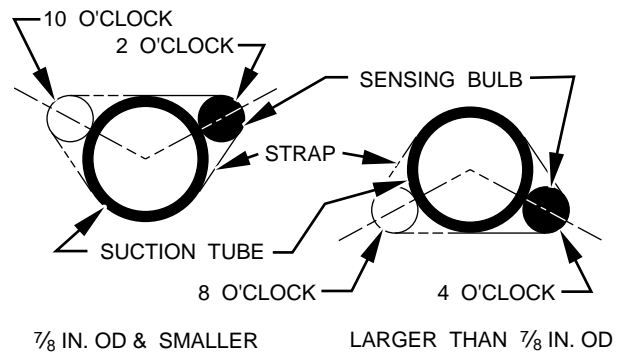

**Fig. 6—Positioning of Sensing Bulb**

A81032

**⚠ CAUTION**

**UNIT DAMAGE HAZARD**

Failure to follow this caution may result in unit component damage.

Do not leave system open to atmosphere any longer than minimum required for installation. POE oil in compressor is extremely susceptible to moisture absorption. Always keep ends of tubing sealed during installation.

**⚠ CAUTION**

**UNIT DAMAGE HAZARD**

Failure to follow this caution may result in unit component damage.

If ANY refrigerant tubing is buried, provide a 6 in. vertical rise at service valve. Do NOT bury refrigerant tubing lengths longer than 36 in.

**⚠ CAUTION**

**UNIT DAMAGE HAZARD**

Failure to follow this caution may result in unit component damage.

To prevent damage to unit or service valves observe the following:

- Use a brazing shield.
- Wrap service valves with wet cloth or use a heat sink material.

Outdoor units may be connected to indoor section using accessory tubing package or field-supplied refrigerant grade tubing of correct size and condition. For tubing requirements beyond 50 ft, substantial capacity and performance losses can occur. Follow the recommendations in the Application Guideline and Service Manual for Residential Split-System Air Conditioners and Heat Pumps Using Puron Refrigerant to minimize losses. Refer to Table 1 for field tubing diameters. Refer to Table 2 for accessory requirements.

Refrigerant tubes and indoor coil must be evacuated to 500 microns to minimize contamination and moisture in the system.

**OUTDOOR UNIT CONNECTED TO FACTORY-APPROVED INDOOR UNIT**

These outdoor units are carefully evaluated and listed with specific indoor coils for proper system performance.

**IMPORTANT:** Do not apply indoor coils which are not factory approved to these units.

**INSTALL ADAPTER TUBE (030-060 SIZES ONLY)**

1. Remove plastic retainer holding outdoor piston in liquid service valve.
2. Check outdoor piston size with matching number listed on unit rating plate.
3. Locate plastic bag taped to unit containing adapter tube.
4. Remove Teflon washer from bag and install on open end of liquid service valve. (See Fig. 8.)
5. Remove adapter tube from bag and connect threaded nut to liquid service valve. Tighten nut finger tight and then with wrench an additional 1/2 turn (15 ft-lb). DO NOT OVERTIGHTEN!

**REFRIGERANT TUBING AND FILTER DRIER**

**IMPORTANT:** Installation of filter drier in liquid line is required.

Connect vapor tubing to fittings on outdoor unit vapor service valve. Connect liquid tubing to filter drier (See Table 1 and Fig. 9.) Use refrigerant grade tubing. Connect other end of filter drier to adapter tube on liquid service valve.

**SWEAT CONNECTION**

**⚠ CAUTION**

**UNIT DAMAGE HAZARD**

Failure to follow this caution may result in unit component damage.

To avoid valve damage while brazing, service valves must be wrapped in a heat-sinking material such as a wet cloth.

Wrap service valves and filter drier with a wet cloth or heat-sinking material. Braze connections using either silver bearing or non-silver bearing brazing material. Do not use soft solder (materials which melt below 800°F). Consult local code requirements.

**LEAK CHECKING**

Leak test all joints in indoor, outdoor, and refrigerant tubing.

**Table 1—Refrigerant Connections and Recommended Liquid and Vapor Tube Diameters (In.)**

UNIT SIZE	CONNECTION DIAMETER		TUBE DIAMETER		TUBE DIAMETER (ALTERNATE)
	Liquid	Vapor	Liquid	Vapor	Vapor
024	3/8	5/8	3/8	5/8	3/4
030	3/8	3/4	3/8	3/4	5/8, 7/8
036	3/8	3/4	3/8	3/4	5/8, 7/8
042, 048	3/8	7/8	3/8	7/8	3/4
060	3/8	7/8	3/8	1-1/8	7/8

**NOTES:**

1. Tube diameters are for lengths up to 50 ft. For tubing lengths greater than 50 ft horizontal and/or 20 ft vertical differential, consult the Application Guideline and Service Manual for Residential Split-System Air Conditioners and Heat Pumps Using Puron Refrigerant.
2. Refrigerant tubes and indoor coils must be evacuated to 500 microns to minimize contamination and moisture in the system.
3. If required by local codes, Pressure Guard™ kit is available. See Product Data Digest for part numbers.

**Table 2—Accessory Usage**

ACCESSORY	REQUIRED FOR LOW-AMBIENT APPLICATIONS (BELOW 55°F)	REQUIRED FOR LONG-LINE APPLICATIONS* (OVER 50 FT)
Crankcase Heater	Yes	Yes
Evaporator Freeze Thermostat	Yes	No
Compressor Start Assist—Capacitor and Relay	Yes	Yes
Puron Low-Ambient Pressure Switch	Yes	No
Wind Baffle	See Low-Ambient Instructions	No
Support Feet	Recommended	No
Puron Hard Shutoff TXV	Yes†	Yes†
Puron Liquid-Line Solenoid Valve for Heating	No	See Long-Line Application Guideline

\* For tubing line sets between 50 and 175 ft, refer to the Application Guideline and Service Manual for Residential Split-System Air Conditioners and Heat Pumps using Puron Refrigerant.

† Required for all applications.

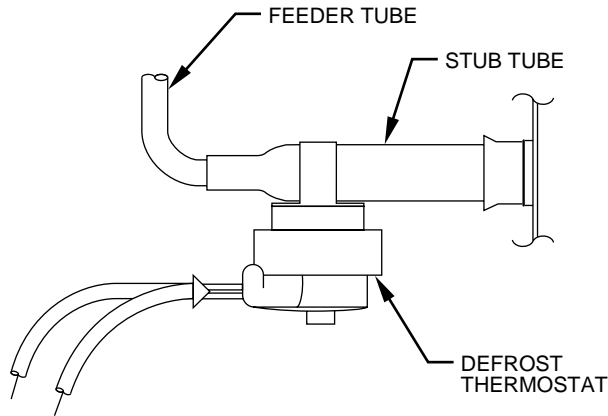

A97517

**Fig. 7—Defrost Thermostat Location**

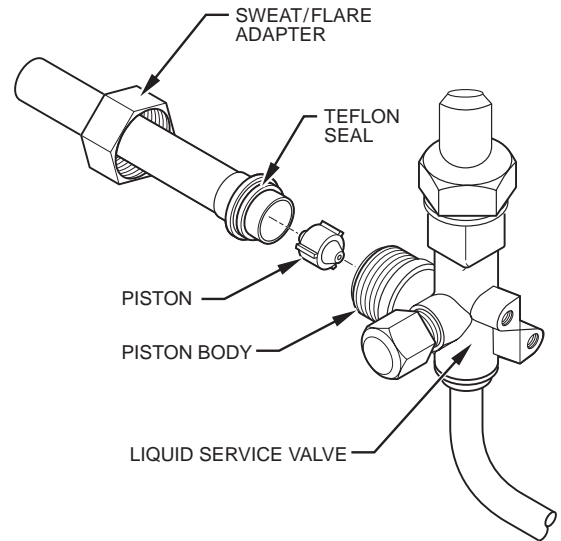

A01214

**Fig. 8—Liquid Service Valve with Sweat Adapter Tube (030-060 Sizes Only)**

**EVACUATE REFRIGERANT TUBING AND INDOOR COIL**

**CAUTION**

**UNIT DAMAGE HAZARD**

Failure to follow this caution may result in unit component damage.

To avoid compressor damage, never use the system compressor as a vacuum pump.

Refrigerant tubes and indoor coil must be evacuated using the recommended deep vacuum method of 500 microns. The alternate triple evacuation method may be used if the procedure outlined below is followed.

**IMPORTANT:** Never open system under vacuum to atmosphere without first breaking it open with nitrogen.

**Deep Vacuum Method**

The deep vacuum method requires a vacuum pump capable of pulling a vacuum of 500 microns and a vacuum gage capable of accurately measuring this vacuum depth. The deep vacuum method is the most positive way of assuring a system is free of air and liquid water. (See Fig. 10.)

**Triple Evacuation Method**

The triple evacuation method should only be used when vacuum pump is only capable of pumping down to 28 in. of mercury vacuum and system does not contain any liquid water. Refer to Fig. 11 and proceed as follows:

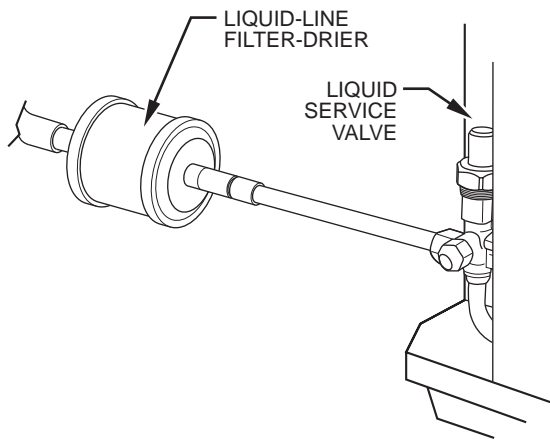

A01215

**Fig. 9—Filter Drier with Sweat Adapter Tube and Liquid Tube**

1. Pump system down to 28 in. of mercury and allow pump to continue operating for an additional 15 minutes.
2. Close service valves and shut off vacuum pump.
3. Connect a nitrogen cylinder and regulator to system and open until system pressure is 2 psig.
4. Close service valve and allow system to stand for 1 hr. During this time, dry nitrogen will be able to diffuse throughout the system absorbing moisture.
5. Repeat this procedure as indicated in Fig. 11. System will then contain minimal amounts of contaminants and water vapor.

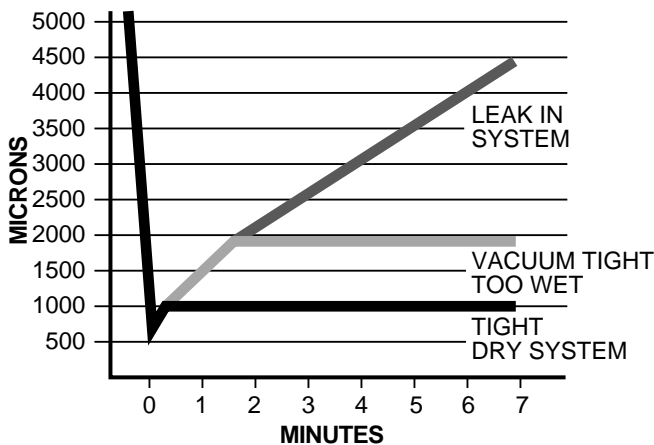

A95424

**Fig. 10—Deep Vacuum Graph**

**FINAL TUBING CHECK**

**IMPORTANT:** Check to be certain factory tubing on both indoor and outdoor unit has not shifted during shipment. Ensure tubes are not rubbing against each other or any sheet metal. Pay close attention to feeder tubes, making sure wire ties on feeder tubes are secure and tight.

**Step 10—Make Electrical Connections**

**⚠ WARNING**

**ELECTRICAL SHOCK HAZARD**  
 Failure to follow this warning could result in death or personal injury.  
 To avoid personal injury or death, do not supply power to unit with compressor terminal box cover removed.

Be sure field wiring complies with local and national fire, safety, and electrical codes, and voltage to system is within limits shown

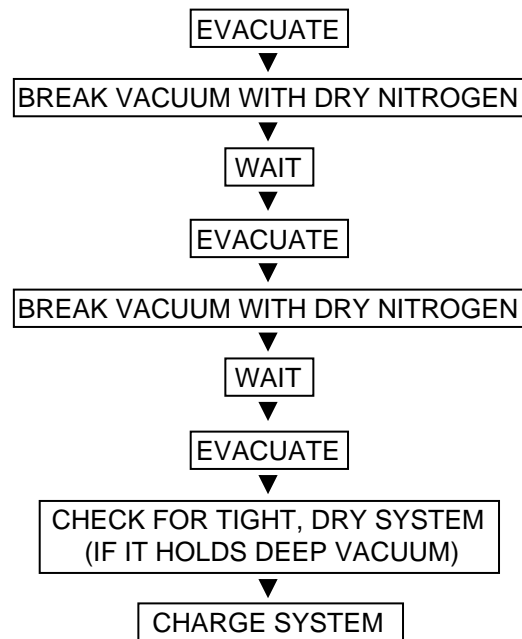

A95425

**Fig. 11—Triple Evacuation Method**

on unit rating plate. Contact local power company to correct improper voltage. See unit rating plate for recommended circuit protection device.

**NOTE:** Operation of unit on improper line voltage constitutes abuse and could affect unit reliability. See unit rating plate. Do not install unit in system where voltage may fluctuate above or below permissible limits.

**NOTE:** Use copper wire only between disconnect switch and unit.

**NOTE:** Install branch circuit disconnect of adequate size per NEC to handle unit starting current. Locate disconnect within sight from and readily accessible from unit, per Section 440-14 of NEC.

**ROUTE GROUND AND POWER WIRES**

Remove access panel to gain access to unit wiring. Extend wires from disconnect through power wiring hole provided and into unit control box.

**⚠ WARNING**

**ELECTRICAL SHOCK HAZARD**  
 Failure to follow this warning could result in death or personal injury.  
 The unit cabinet must have an uninterrupted or unbroken ground to minimize personal injury if an electrical fault should occur. The ground may consist of electrical wire or metal conduit when installed in accordance with existing electrical codes. Failure to follow this warning can result in an electric shock, fire, or death.

**CONNECT GROUND AND POWER WIRES**

Connect ground wire to ground connection in control box for safety. Connect power wiring to contactor as shown in Fig. 12.

**CONNECT CONTROL WIRING**

Route 24v control wires through control wiring grommet and connect leads to control wiring. (See Fig. 13.) See Thermostat Installation Instructions for wiring specific unit combinations.

Use No. 18 AWG color-coded, insulated (35°C minimum) wire. If thermostat is located more than 100 ft from unit, as measured along the control voltage wires, use No. 16 AWG color-coded wire to avoid excessive voltage drop.

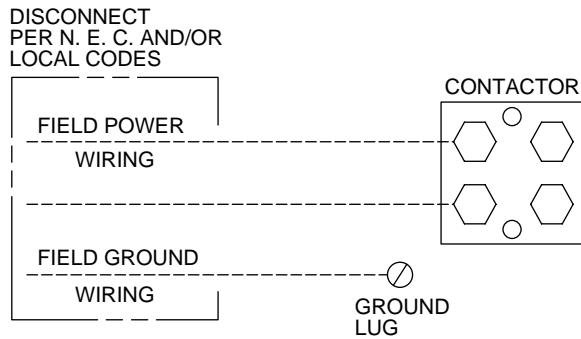

A91056

**Fig. 12—Line Power Connections**

All wiring must be NEC Class 1 and must be separated from incoming power leads.

Use furnace transformer, fan coil transformer, or accessory transformer for control power, 24-v/40-va minimum.

**NOTE:** Use of available 24-v accessories may exceed the minimum 40-va power requirement. Determine total transformer loading and increase the transformer capacity or split the load with an accessory transformer as required.

**FINAL WIRING CHECK**

**IMPORTANT:** Check factory wiring and field wire connections to ensure terminations are secured properly. Check wire routing to ensure wires are not in contact with tubing, sheet metal, etc.

**Step 11—Compressor Crankcase Heater**

When equipped with a crankcase heater, furnish power to heater a minimum of 24 hr before starting unit. To furnish power to heater only, set thermostat to OFF and close electrical disconnect to outdoor unit.

A crankcase heater is required in long-line applications (tubing greater than 50 ft or elevation greater than 8 ft) between indoor and outdoor units. Refer to the Application Guideline and Service Manual for Residential Split-System Air Conditioners and Heat Pumps Using Puron Refrigerant.

**Step 12—Install Electrical Accessories**

Refer to the individual instructions packaged with kits or accessories when installing.

**Step 13—Start-Up**

**⚠ WARNING**

**EXPLOSION AND UNIT DAMAGE HAZARD**  
Failure to follow this warning could cause death, personal injury, or unit damage.  
Observe the following:

- Do not overcharge system with refrigerant.
- Do not operate unit in a vacuum or at negative pressure.
- Do not disable low-pressure switch.

In scroll compressor applications:

- Dome temperatures may be hot.

**⚠ WARNING**

**EXPLOSION, BURN, PERSONAL HAZARD**  
Failure to follow this warning could result in death or personal injury. To prevent personal injury wear safety glasses, protective clothing, and gloves when handling refrigerant.

**⚠ CAUTION**

**UNIT DAMAGE HAZARD**  
Failure to follow this caution may result in unit component damage.  
Back seating service valves are not equipped with Schrader valves. Fully back seat (counter clockwise) valve stem before removing gage port cap.

**⚠ CAUTION**

**ENVIRONMENTAL HAZARD**  
Failure to follow this caution may lead to fines or environmental impact.  
Federal regulations require that you do not vent refrigerant to atmosphere. Recover during system repair or final unit disposal.

Follow these steps to properly start up the system:

1. Fully back seat (open) liquid and vapor service valves.
2. Unit is shipped with valve stem(s) front seated (closed) and caps installed. Replace stem caps after system is opened to refrigerant flow (back seated). Replace caps finger-tight and tighten with wrench an additional 1/12 turn. Use a backup wrench on valve body flats to prevent distortion of sheet metal.
3. Close electrical disconnects to energize system.
4. Set room thermostat at desired temperature. Be sure set point is below indoor ambient temperature.
5. Set room thermostat to HEAT or COOL and fan control to ON or AUTO mode, as desired. Operate unit for 15 minutes. Check system refrigerant charge.

**SEQUENCE OF OPERATION**

**NOTE:** Defrost control board is equipped with a 5-minute lock-out timer which may be initiated upon an interruption of power. With power supplied to indoor units, transformer is energized.

Cooling

On a call for cooling, thermostat makes R-O, R-Y, and R-G. Circuit R-O energizes reversing valve, switching it to cooling position. Circuit R-Y sends low voltage through the safeties and energizes the T1 terminal on the circuit board. If the compressor has been off for 5 minutes, or power has not been cycled for 5 minutes, T2 will energize, which closes the contactor, starting the outdoor fan motor and compressor.

When the cycle is complete, R-Y is turned off and compressor and outdoor fan should stop. The 5-minutes timer begins counting. Compressor will not come on again until this time delay expires. In the event of a power interruption, the timer will not allow another cycle for 5 minutes.

**NOTE:** If indoor unit is equipped with a time-delay relay circuit, the blower runs an additional 90 sec to increase system efficiency.

Heating

On a call for heating, thermostat makes R-Y and R-G. Circuit R-Y sends low voltage through the safeties and energizes the T1 terminal on the circuit board. T1 energizes the defrost logic circuit. If the compressor has been off for 5 minutes, or power has not been cycled for 5 minutes, T2 will energize which closes the contactor, starting outdoor fan motor and compressor.

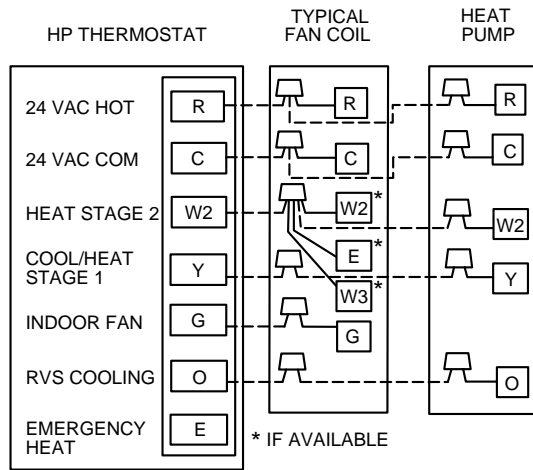

**Fig. 13—Generic Wiring Diagram**  
 (See Thermostat Installation Instructions  
 for wiring specific unit combinations.)

A02325

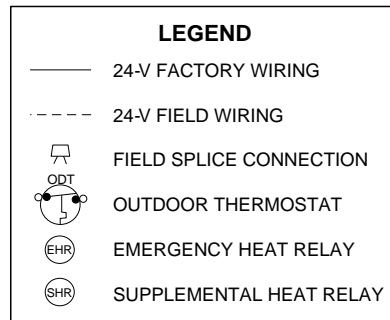

When the cycle is complete, R-Y is turned off and compressor and outdoor fan should stop. The 5 minute timer begins counting. Compressor will not come on again until this time delay expires. In the event of a power interruption, the timer will not allow another cycle for 5 minutes.

#### Quiet Shift

Quiet Shift is a field-selectable defrost mode (factory set to OFF position), which will eliminate occasional noise that could be heard at the start of defrost cycle and restarting of heating cycle. It is selected by placing DIP switch 3 (on defrost board) in ON position.

When Quiet Shift switch is placed in ON position, and a defrost is initiated, the following sequence of operation will occur. Reversing valve will energize, compressor will turn off for 30 seconds, turn back on to complete defrost. At the start of heating after conclusion of defrost reversing valve will de-energize, compressor will turn off for another 30 seconds, and the fan will turn off for 40 seconds, before starting in the heating mode.

#### Defrost Sequence

The defrost control is a time/temperature control which includes a field-selectable time period (DIP switch 1 and 2 on the board) of 30, 60, 90, or 120 minutes (factory set at 90 minutes).

The defrost thermostat senses coil temperature throughout the heating cycle. When the coil temperature reaches the defrost thermostat setting of approximately 30 degrees, it will close, which energizes the DFT terminal and begins the defrost timing sequence. When the DFT has been energized for the selected time, the defrost cycle begins.

Defrost cycle is terminated automatically after 10 minutes or when defrost thermostat opens.

#### Forced Defrost

To initiate a forced defrost, two options are available depending on the status of the defrost thermostat.

If defrost thermostat is closed, speedup pins (J1) must be shorted by placing a flat head screw driver in between for 5 seconds and **releasing**, to observe a complete defrost cycle. When the Quiet Shift switch is selected, compressor will be turned off for two 30 second intervals during this complete defrost cycle, as explained previously. When Quiet Shift switch is in factory default OFF position, a normal and complete defrost cycle will be observed.

If defrost thermostat is in open position, and speedup pins are shorted (with a flat head screw driver) for 5 seconds and **released**, a short defrost cycle will be observed (actual length is dependent upon the selected Quiet Shift position). When Quiet Shift switch is in ON position, the length of defrost is 1 minute (30 seconds compressor off period followed by 30 seconds of defrost with compressor operation). On return to heating operation, compressor will again turn off for an additional 30 seconds and the fan for 40 seconds. When the Quiet Shift is in OFF position, only a brief 30 second cycle will be observed.

If it is desirable to observe a complete defrost in warmer weather, the thermostat must be closed as follows.

1. Turn off power to outdoor unit.
2. Disconnect outdoor fan motor lead from OF2 on control board (See Fig. 14). Tape to prevent grounding.
3. Restart unit in heating mode, allowing frost to accumulate on outdoor coil.



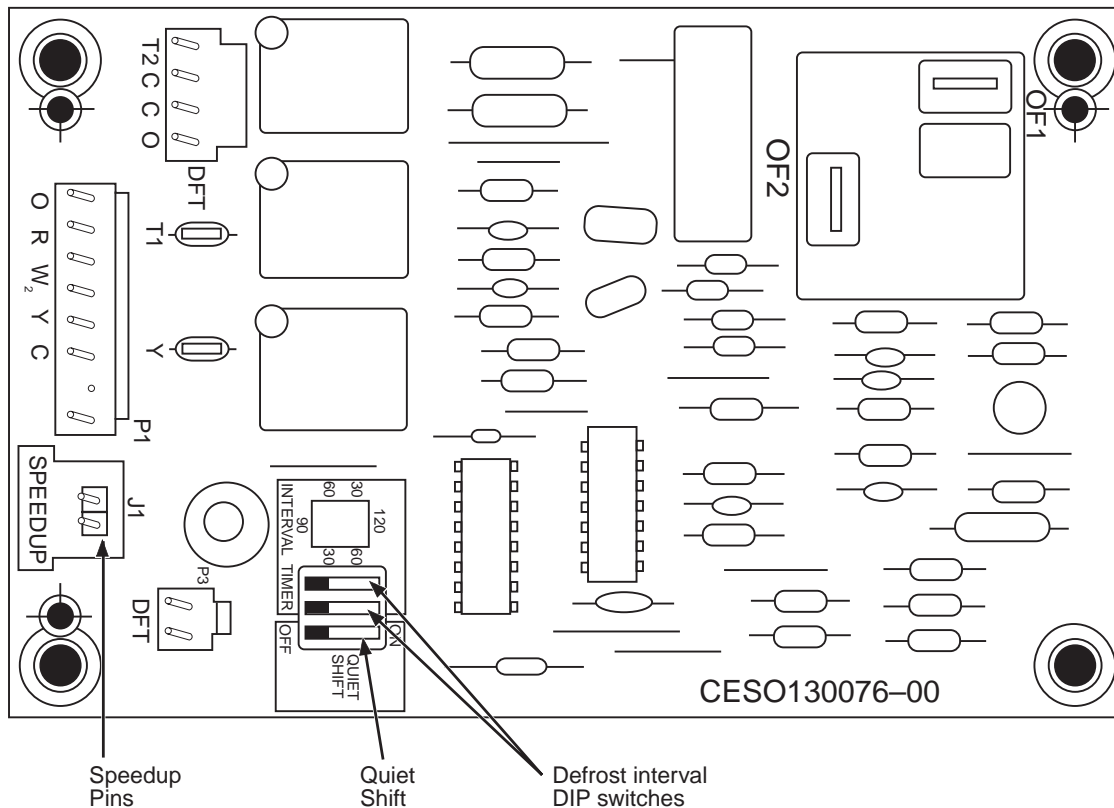

**Fig. 14—Defrost Control**

A99442

- After a few minutes in heating mode, liquid line temperature should drop below closing point of defrost thermostat (approximately 30°F).

**NOTE:** Unit will remain in defrost until defrost thermostat reopens at approximately 80°F coil temperature at liquid line or remainder of defrost cycle time.

- Turn off power to outdoor and reconnect fan motor lead to OF2 on control board after above forced defrost cycle.

#### Step 14—Check Charge

##### UNIT CHARGE

Factory charge is shown on unit rating plate. To check charge in cooling mode, refer to Cooling Only Procedure. To check charge in heating mode, refer to Heating Check Chart Procedure (030-060 sizes).

##### HEATING PROCEDURE FOR 024 SIZE

- Defrost unit before checking charge. Outdoor coil must be free of frost and/or ice.
- Accumulator may momentarily hold refrigerant after defrost cycle, therefore, allow 15 min of normal operation following defrost cycle before checking charge.
- This outdoor unit is equipped with a thermal expansion device, therefore the subcooling chart may be used for checking purposes only.

With unit operating, charge Puron units with liquid using a commercial-type metering device in manifold hose. Charge refrigerant into suction line. Some refrigerant cylinders may contain a dip tube that allows liquid refrigerant to flow from cylinder in upright position. Check cylinder label for correct position to allow liquid flow.

##### COOLING ONLY PROCEDURE

**NOTE:** If subcooling charging conditions are not favorable, charge must be weighed in accordance with unit rating plate  $\pm 0.6$

oz/ft of 3/8-in. liquid line above or below 15 ft respectively.

##### EXAMPLE:

To calculate additional charge required for a 25-ft line set:

$$25 \text{ ft} - 15 \text{ ft} = 10 \text{ ft} \times 0.6 \text{ oz/ft} = 6 \text{ oz of additional charge}$$

Units installed with cooling mode TXV require charging with the subcooling method.

- Operate unit a minimum of 10 minutes before checking charge.
- Measure liquid service valve pressure by attaching an accurate gage to service port.
- Measure liquid line temperature by attaching an accurate thermistor type or electronic thermometer to liquid line near outdoor coil.
- Refer to Heat Pump Charging Instructions label on outdoor unit for required subcooling temperature.
- Refer to Table 3. Find the point where required subcooling temperature intersects measured liquid service valve pressure.
- To obtain required subcooling temperature at a specific liquid line pressure, add refrigerant if liquid line temperature is higher than indicated or reclaim refrigerant if temperature is lower. Allow a tolerance of  $\pm 3^\circ\text{F}$ .

##### HEATING CHECK CHART PROCEDURE (030-060 SIZES)

To check system operation during heating cycle, refer to the Heat Pump Charging Instructions label on outdoor unit. This chart indicates whether a correct relationship exists between system operating pressure and air temperature entering indoor and outdoor units. If pressure and temperature do not match on chart, system refrigerant charge may not be correct. Do not use chart to adjust refrigerant charge.

**NOTE:** In heating mode, check refrigerant charge only when pressures are stable. If in doubt, remove charge and weigh in correct refrigerant charge.

**Table 3—Required Liquid-Line Temperature (°F)**

LIQUID PRESSURE AT SERVICE VALVE (PSIG)	REQUIRED SUBCOOLING TEMPERATURE (°F)			
	5	10	15	20
174	56	51	46	41
181	58	53	48	43
188	61	56	51	46
195	63	58	53	48
202	65	60	55	50
209	67	62	57	52
216	69	64	59	54
223	71	66	61	56
230	73	68	63	58
237	75	70	65	60
244	77	72	67	62
251	79	74	69	64
258	81	76	71	66
265	82	77	72	67
272	84	79	74	69
279	86	81	76	71
286	88	83	78	73
293	89	84	79	74
300	91	86	81	76
307	93	88	83	78
314	94	89	84	79
321	96	91	86	81
328	97	92	87	82
335	99	94	89	84
342	100	95	90	85
349	102	97	92	87
356	103	98	93	88
363	105	100	95	90
370	106	101	96	91
377	107	102	97	92
384	109	104	99	94
391	110	105	100	95
398	112	107	102	97
405	113	108	103	98
412	114	109	104	99
419	115	110	105	100
426	117	112	107	102
433	118	113	108	103
440	119	114	109	104
447	120	115	110	105
454	122	117	112	107
461	123	118	113	108
468	124	119	114	109
475	125	120	115	110
482	126	121	116	111
489	127	122	117	112
496	129	124	119	114
503	130	125	120	115
510	131	126	121	116
517	132	127	122	117
524	133	128	123	118
531	134	129	124	119
538	135	130	125	120
545	136	131	126	121
552	137	132	127	122
559	138	133	128	123
566	139	134	129	124
573	140	135	130	125
580	141	136	131	126
587	142	137	132	127
594	143	138	133	128
601	144	139	134	129
608	145	140	135	130

**NOTE:** When charging is necessary during heating season, charge must be weighed in accordance with unit rating plate  $\pm$  0.6 oz/ft of 3/8-in. liquid line above or below 15 ft respectively.

EXAMPLE:

To calculate additional charge required for a 25-ft line set:

25 ft - 15 ft = 10 ft X 0.6 oz/ft = 6 oz of additional charge

### Step 15—Final Checks

**IMPORTANT:** Before leaving job, be sure to do the following:

1. Securely fasten all panels and covers.
2. Tighten service valve stem caps to 1/12-turn past finger tight.
3. Leave User's Manual with owner. Explain system operation and periodic maintenance requirements outlined in manual.
4. Fill out Dealer Installation Checklist and place in customer file.

### CARE AND MAINTENANCE

For continuing high performance and to minimize possible equipment failure, periodic maintenance must be performed on this equipment.

Frequency of maintenance may vary depending upon geographic areas, such as coastal applications.

## PURON®—QUICK REFERENCE GUIDE

- Puron refrigerant operates at 50-70 percent higher pressures than R-22. Be sure that servicing equipment and replacement components are designed to operate with Puron.
- Puron refrigerant cylinders are rose colored.
- Recovery cylinder service pressure rating must be 400 psig, DOT 4BA400 or DOT BW400.
- Puron systems should be charged with liquid refrigerant. Use a commercial type metering device in the manifold hose.
- Manifold sets should be 750 psig high side and 200 psig low side with 520 psig low-side retard.
- Use hoses with 750 psig service pressure rating.
- Leak detectors should be designed to detect HFC refrigerant.
- Puron, as with other HFCs, is only compatible with POE oils.
- Vacuum pumps will not remove moisture from oil.
- Do not use liquid-line filter driers with rated working pressures less than 600 psig.
- Do not install a suction-line filter drier in liquid line.
- POE oils absorb moisture rapidly. Do not expose oil to atmosphere.
- POE oils may cause damage to certain plastics and roofing materials.
- Wrap all filter driers and service valves with wet cloth when brazing.
- A liquid-line filter drier is required on every unit.
- Do not use an R-22 TXV.
- If indoor unit is equipped with an R-22 TXV, it must be changed to an Puron TXV.
- Never open system to atmosphere while it is under a vacuum.
- When system must be opened for service, break vacuum with dry nitrogen prior to opening to atmosphere.
- Always replace filter drier after opening system for service.
- Do not vent Puron into the atmosphere.
- Do not use capillary tube coils.
- Observe all **warnings**, **cautions**, and **bold** text.

# SERVICE TRAINING

**Packaged Service Training** programs are an excellent way to increase your knowledge of the equipment discussed in this manual, including:

- Unit Familiarization • Maintenance
- Installation Overview • Operating Sequence

A large selection of product, theory, and skills programs is available, using popular video-based formats and materials. All include video and/or slides, plus companion book.

**Classroom Service Training** plus "hands-on" the products in our labs can mean increased confidence that really pays dividends in faster troubleshooting, fewer callbacks. Course descriptions and schedules are in our catalog.

**CALL FOR FREE CATALOG 1-800-644-5544**

[ ] Packaged Service Training [ ] Classroom Service Training

A94328