

---

39 HQ  
AiroVision

---

**Installation, Operation and  
Maintenance Instructions**

---



39 HQ  
AiroVision

**Installation, Operation and  
Maintenance Instructions**

Contents

<b>1 - SAFETY CONSIDERATIONS</b> .....	<b>5</b>
1.1. General .....	5
1.2. Applications .....	5
1.3. Instruction Types .....	5
1.4. Disposal of Parts/Materials .....	6
<b>2. TRANSPORT AND LIFTING INSTRUCTIONS</b> .....	<b>6</b>
2.1. General .....	6
2.2. Transport and Storage .....	6
2.3. Roof edge protection during transport (outside installation) .....	7
2.4. Offloading and Hoisting .....	7
2.5. Horizontal Transport .....	7
<b>3. PREPARATION for ASSEMBLY</b> .....	<b>8</b>
<b>4. LIFTING INSTRUCTIONS</b> .....	<b>8</b>
4.1. General .....	8
4.2. Lifting Bar Certification .....	8
4.3. Fastening of the Lifting Bars .....	8
<b>5. ASSEMBLY</b> .....	<b>8</b>
5.1. AHU Assembly .....	9
5.2. Connecting Casings of Equal Width and Height .....	10
5.3. Connecting Casings of Different Height .....	12
<b>6. STACKED CASING SECTIONS</b> .....	<b>12</b>
6.1 Unit without Intermediate Base Frame (Equal Width) .....	12
6.2. Unit with Intermediate Base Frame (Equal Width) .....	14
6.3. Units with Different Width .....	16
<b>7. FRESH AIR INLET HOOD</b> .....	<b>19</b>
<b>8. ROOF COVER</b> .....	<b>19</b>
<b>9. CHECKLIST of START-UP CHECK POINTS</b> .....	<b>20</b>
9.1. Checklist of Start-up Check Points .....	20
<b>10. START-UP INSTRUCTIONS</b> .....	<b>22</b>
10.1. Casing .....	22
10.2. Casing Panels .....	22
10.3 Doors and Access Covers .....	22
10.4. Flexible Connections .....	22
10.5. Earthing .....	22
10.6. AHU Installation and Connection .....	22
10.7. Dampers .....	23
10.8. Air Filters .....	23
10.9.1. General .....	23
10.9.2. Electric Heaters .....	23

10.9.3. Steam Heaters.....	23
10.10. Siphone .....	24
10.11. Coolers .....	24
10.12. Heat Recovery Wheel.....	25
10.13. Plate Heat Exchanger.....	25
10.14. Direct Steam Humidification .....	25
10.15. Electrical Steam Humidification .....	25
10.16. Water Humidifiers .....	26
10.16.1. Spray Humidifiers .....	26
10.16.2. Infrasonic Humidifier.....	26
10.17. Fan .....	26
10.18. Sound Attenuator.....	26
10.19. Lighting .....	26
11. MAINTENANCE CHECKLIST .....	27
11.1. Checklist for Check Points and Maintenance Intervals.....	27
12. MAINTENANCE AND OPERATING INSTRUCTIONS .....	29
12.1. General.....	29
12.2. Casing Panels .....	29
12.2.1. Inside Installation.....	29
12.2.2. Outside Installation.....	29
12.3. Doors and Access Covers .....	29
12.4. Flexible Connections .....	29
12.5. Earthing .....	29
12.6. Dampers.....	29
12.7. Outside Air Intake .....	29
12.8. Filters.....	29
12.9. Heaters .....	29
12.9.1. Water, Glycol and Steam Heat Exchangers .....	29
12.9.2. Electric Heaters .....	30
12.10. Coolers .....	30
12.11. Heat Recovery Wheel.....	30
12.12. Plate Heat Exchanger.....	30
12.13. Water Humidification .....	30
12.13.1. Steam Humidifier .....	30
12.13.2. Spray Humidifier .....	30
12.13.3. Infrasonic Humidifier.....	31
12.14.3. Transmission .....	31
12.14.2. Bearings .....	31
12.14.1. General.....	31
12.14. Fan .....	31
12.15. Sound Attenuator.....	31
Appendix-1 .....	32
Appendix-2 .....	33
Appendix-3/1 .....	38
Appendix-3/2 .....	39

## **1 - SAFETY CONSIDERATIONS**

### **1.1. General**

The 39HQ air handling units (AHUs) has been designed and manufactured in accordance with the CE machine directive EN292. In order to guarantee safe operation and use of the unit, please carefully read and observe the instructions in this document and pay special attention to the warnings that apply to this unit. Any modifications in the design and/or installation of the AHU that are carried out without discussion with Alarko Carrier and without advance written agreement will result in the loss of the right to any warranty claims and any claim for injury to personnel as a result of these modifications.

Maintenance procedures may only be carried out by qualified personnel.

Heating and cooling elements are manufactured and supplied in accordance with guidelines of the Pressure Equipment Directive (PED).

CE declaration of AHUs is given Annex-4.

### **1.2. Applications**

The AHU is designed for the movement and conditioning of air, unless otherwise agreed during the design stage.

### **1.3. Instruction Types**

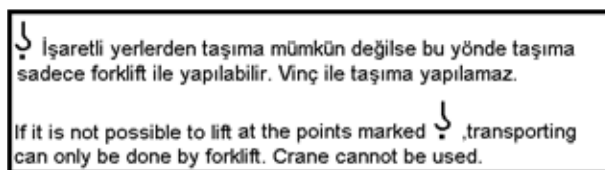
The following warning pictograms and labels with text are used.



***Lifting Point***

This label shows where the AHU can be lifted with support beams. Support beams shall be used with cranes. If forklifts are used for lifting, support beams cannot be used.

### ***Transporting From Side Base***



It is forbidden to place lifting devices for transport and storage under side profiles.

### ***Earthing***

This pictogram indicates where the AHU must be earthed and is on one of the support beams beneath the casing in the fan section.

- The electrical components in the AHU must be earthed, except for components with double insulation and/or components with a supply voltage below 50 V.

- The electrical components must be installed in accordance with national and local regulations.



### ***Rotating Parts***

This pictogram indicates that there are rotating parts behind this access cover, door or panel which may cause injury. The components that include rotating parts are the fan and heat recovery wheel. If there are special customer-specific components behind doors, access covers or panels that include rotating parts and pose a potential risk, this is also indicated by this pictogram.



### ***Hot Surfaces***

This pictogram indicates that there are components behind this access cover, door or panel that can cause serious burns when touched.

The components that may have hot surfaces are the steam humidifier, steam heater and the electric heater. If there are special customer-specific components behind doors, access covers or panels that have hot surfaces and pose a potential risk, this is also indicated by this pictogram.



### Electrical Voltage

This pictogram indicates that there are electrical components behind this access cover, door or panel that may be dangerous for the user/installer. Only personnel qualified in accordance with EN50110 is permitted to carry out work on these components. The pictogram is attached to the access cover for the electric heater control box.



### Removal of Transport Brackets

This pictogram is located at the bottom of the fan section. It indicates that the transport brackets must be removed during commissioning before the fan is started up.



### Central Data

This label contains the data for the AHU, such as order number, position number etc. If present, the label is normally located on the access cover or the door of the fan assembly.



### Opening the Fan Door

This pictogram is positioned on the outside of the door or access cover of the fan assembly. This pictogram warns that the fan must have been switched off and deenergised for a minimum of two minutes before the door or access cover is opened.

**Caution:** All doors and access covers must be closed



before starting up the AHU.

### Unit Matching Label

This label shows that matching surfaces of AHU units for assembly. It exists at bottom right and left corner of units. Sample label is as follows.



### Lifting and Transport

An instruction is attached to the AHU that describes the procedures that must be followed for lifting and transport. The following chapter contains further details.

## 1.4. Disposal of Parts/Materials

- The packaging material must be disposed of in a responsible manner and in accordance with local regulations.
- Components that are replaced, must be disposed of as described above.

## 2. TRANSPORT AND LIFTING INSTRUCTIONS

### 2.1. General

Transport and lifting of the AHU must always be in accordance with the instructions below. If these instructions are not observed, irreparable damage may occur to the unit, and people in the immediate vicinity of the unit are also endangered. Alarko Carrier does not accept any responsibility if these instructions are not observed. Transport and lifting must be carried out by qualified personnel. The AHU must only be lifted with lifting bars supplied by Alarko Carrier. Lifting must be carried out in accordance with local regulations and with the help of certified lifting aids.

### 2.2. Transport and Storage

Lifting of the AHU is only permitted under the designated lifting methods. For transporting, ↓ marked points shall be used. If it is not possible to use ↓ marked points due to the loading conditions, transporting from side profiles can only be done by forklift (cranes cannot be used). This applies to transport as well as storage, and is indicated on the side profiles by warning label.

Air Handling Units deliver to the side by sections. Moving the plastic cover will let the dirt and particulates enter to the unit from openings. Do not move the protection cover unless you complete the installation of the unit.

**2.3. Roof edge protection during transport**  
**(outside installation)**

**Roofedge transport protection**

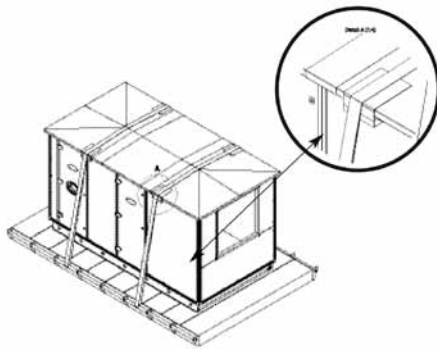
During transport by truck the units are attached to the loading surface with tie ropes, pulled across the unit towards the side edges of the truck.

On external units, to protect the roof edge from distortion by the tie ropes protection plates are added.

For safety reasons these protection plates must be fixed. This is done by attaching them with self-tapping screws to the roof edge.

Make sure that the protection plates are removed after arrival on site before the AHU is lifted.

**Figure 1. Roofedge transport protection**



**2.4. Offloading and Hoisting**

Depending on the dimensions of the AHU and the situation on site, the AHUs are supplied in previously agreed transport sections.

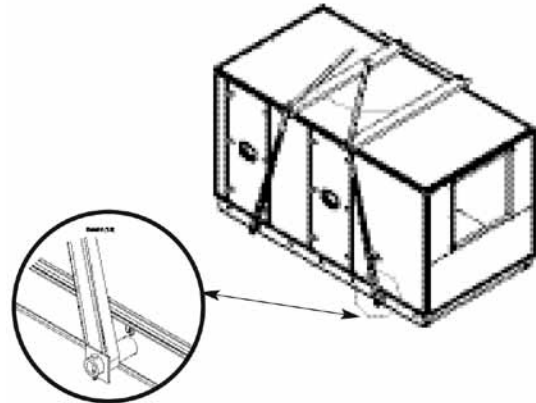
Before proceeding with the transport and installation of the casing sections, always consult the applicable dimensional drawing that give the dimensions and weights of the sections, as well as the installation sequence.

The weight is given on each transport section (See Appendix 1). Each transport section is equipped with a subframe with four lifting points. These points are marked by the label shown below.



For offloading as well as hoisting lifting cables can be attached to the lifting bars. Evenly positioned spacer bars should be used between the lifting cables to prevent damage to the top of the unit and ensure that no excess pressure is applied to the side panels. For hoisting please ensure that the weight is evenly distributed.

**Figure 2. Lifting bars and lifting cables**



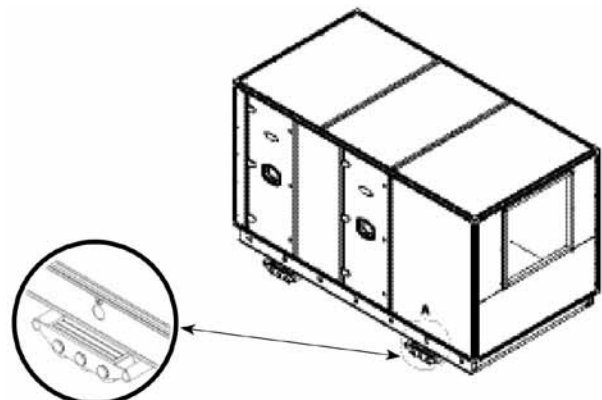
The AHU should not be lifted or moved under the cross beams. This is indicated by the label below.

**Figure 3. Label for not to lifted or moved areas**



**2.5. Horizontal Transport**

For horizontal movement pallet lifters or transport skids can be placed under the installation frame or under the lifting bars. It is important that these support the lifting points. At no time should the cross beams at the ends of the unit sections be used for jacking or tracking the AHU. FOR HORIZONTAL TRANSPORT ALWAYS PROVIDE SUPPORT UNDER THE LIFTING POINTS. The use of bars as rollers can result in damage to the installation frame.



**Figure 4.**

### **3. PREPARATION for ASSEMBLY**

The following material is supplied as standard by Alarko Carrier:

- Installation, maintenance and operating instructions
- Installation, operation and maintenance manual
- II A declaration
- Connecting parts
- Material list

The following material is supplied as an option by Alarko Carrier:

- Anti-vibration mats
- Outside air suction grille
- Heat recovery wheel control
- Steam generator and accessories

Check that all necessary parts are supplied with the AHU.

Measure the location and make sure it is tidy. The floor of the installation area should be level and flat to avoid connection problems. Any uneven surfaces should be evened out with infill plates.

Determine the correct assembly sequence of the AHU sections. Use the most logical sequence, taking the location into account. Begin with the casing section that must be positioned on the highest part of the floor, so that the other casing sections can be added around it.

### **4. LIFTING INSTRUCTIONS**

#### **4.1. General**

There are transport and lifting instructions attached to the AHU.

#### **4.2. Lifting Bar Certification**

The lifting bars supplied are for single use and certified in accordance with Machinery Directive 2006/42/EC, annex II-A. Selection.

#### **4.3. Fastening of the Lifting Bars**

- Remove the bolt and the locking plate on one side of the lifting pipe.

#### ***Figure 5. Fastening the lifting bars - 1***

- Slide the lifting bar into the hole in the subframe intended for that purpose.



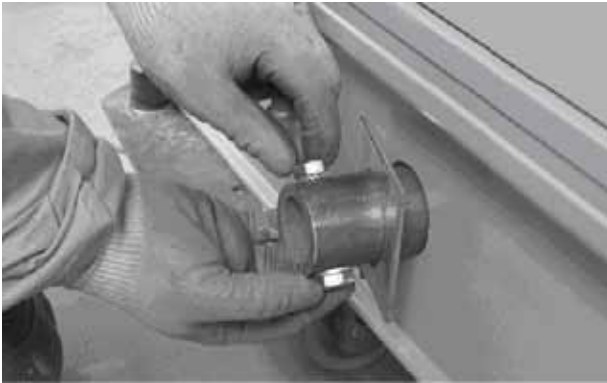


**Figure 6. Fastening the lifting bars - 2**



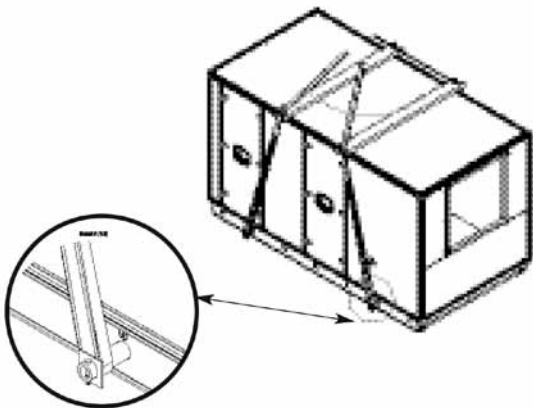
- After inserting the lifting bar, re-insert the bolt and locking plate in the correct position.

**Figure 7. Fastening the lifting bars - 3**



- Position the lifting cables on the lifting bars (4 or 6 off). Evenly positioned spacer bars should be used between the lifting cables to prevent damage to the top of the unit and ensure that no excess pressure is applied to the side panels.

**Figure 8. Vertical transport using spacer bars**

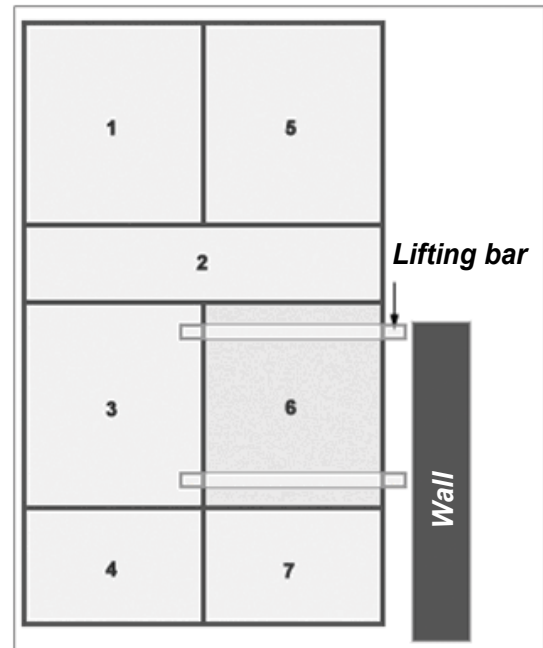


- For hoisting ensure that the weight is evenly distributed and that all previous steps are carried out correctly.

If there is not enough space it may not be possible to remove the lifting bars. In the example below, the lifting bars can not be removed on the right-hand side of the 6th AHU section, as the wall is too close and

the lifting bars are too long. It would be possible to remove them from the left-hand side, if the third AHU section has not yet been placed. Ensure that the bolt and the locking plate are removed from the right-hand side of the lifting bar, when the 6th AHU section has been positioned.

**Figure 9. Location Diagram**



## **5. ASSEMBLY**

### **5.1. AHU Assembly**

- Place the anti-vibration mats where the first casing section will be positioned.
- Place the first casing section on the anti-vibration mats, and then remove the lifting bars.

**Figure 10. Anti-vibration mats**



- Then place the anti-vibration mats where the next casing section will be positioned and then place this section.
- Before placing the sections against each other, fix the sealing tape supplied between the sections. This should be done in four places, and the sealing tape should overlap at the corners See Figs 17 and 21.

The labels which show the matching surfaces are for making easy the matching of unit surfaces correctly during assembly of AHU. Same numbers should be side by side.

**NOTE: Attach the sealing tape supplied to only one of the two assembled sections.**

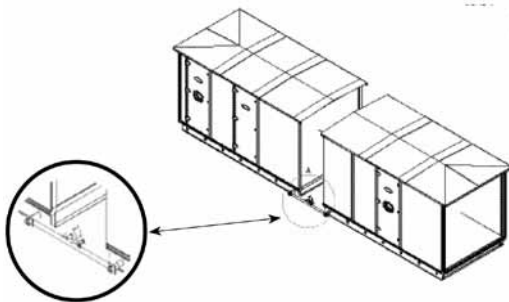
- Place the sections as close together as possible. Ensure that both sections can still be moved. Insert a lifting bar into both sections, so that they can be pulled closer towards each other.

There are two methods for pulling the sections towards each other:

**Method 1**

Pull the sections against each other, using the pull ropes attached to the lifting bars. Pull evenly on both sides of the AHU.

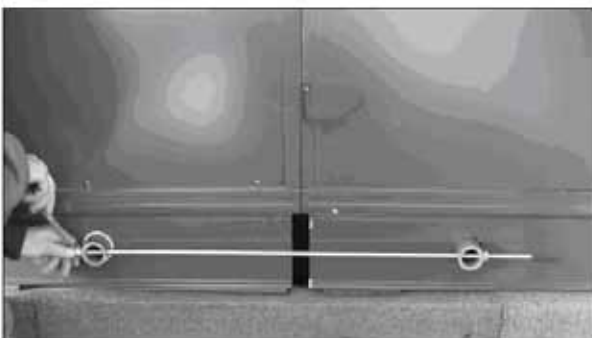
**Figure 11.** Linking the casing sections with pull ropes



**Method 2**

Insert a bar with threaded ends through both lifting bar holes. Screw a nut onto the threaded ends of the bar and tighten it. Tighten it evenly on both sides of the AHU.

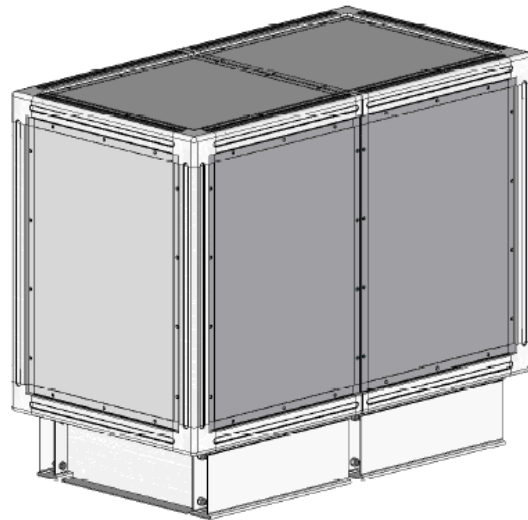
**Figure 12.** Linking the casing section with a bar



**NOTE:** Before connecting the sections, they should be horizontally and vertically aligned, using infill plates. If the floor is not completely level, first place the casing section that will be on the highest part of the floor.

**5.2. Connecting Casings of Equal Width and Height**

**Figure 13.** Unit of equal width and length



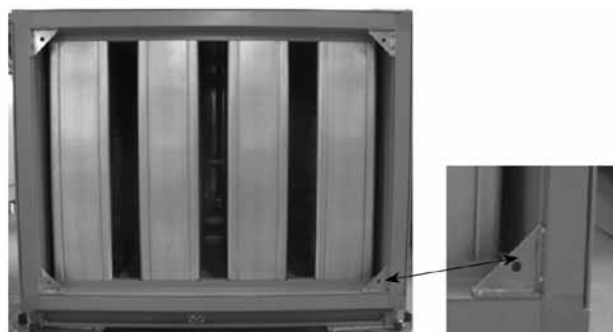
To connect the AHU sections use one of the following methods. The method depends on the AHU construction.

**Method 1**

This method applies for sections that end in joint mullions:

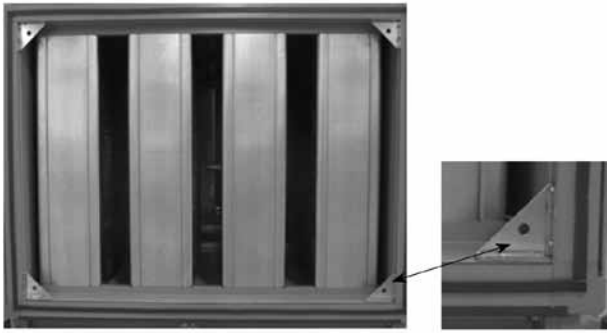
- Check that the four corners are attached.

**Figure 14.** Joint mullions with linking corner plates



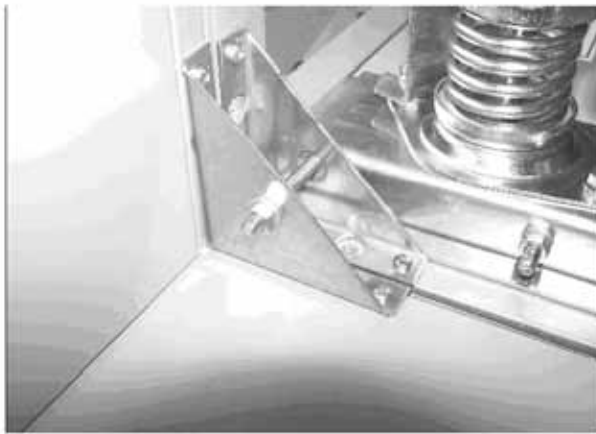
- Ensure that the sealing tape supplied is fixed to one of the two sections, before moving the sections against each other.

**Figure 15.** Fixing the sealing tape to the joint multi-  
ons



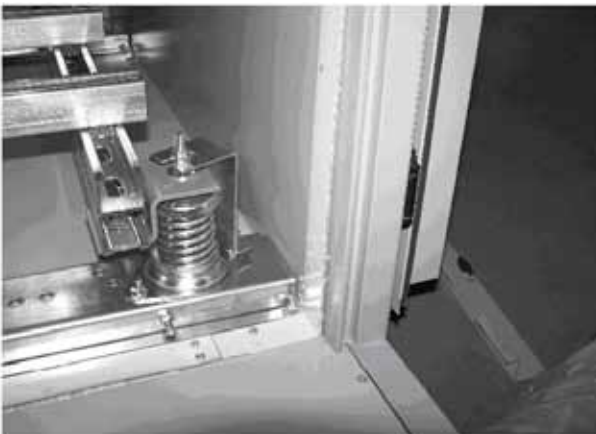
- Use the pre-mounted corners for the final positioning of the sections and secure the corners with a bolt. The sections must be fully aligned.

**Figure 16.** Corner connection



- Remove the first two corners and mount the aluminum connection strip to the base. Remove the next two corners and mount the connection strip against the side wall. Repeat this for the other AHU corners.

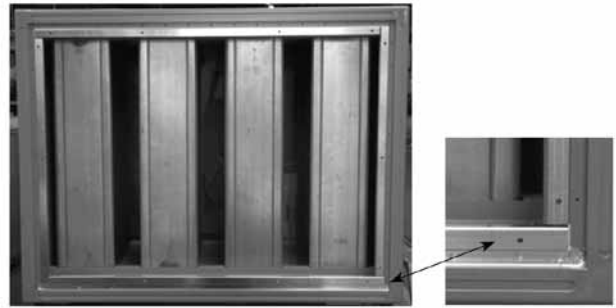
**Figure 17.** Fixing the connection strip



**Method 2**

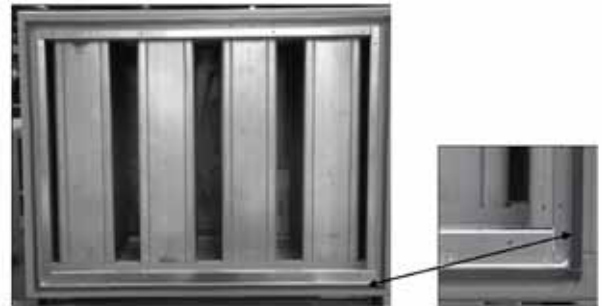
This method applies for sections that end with corner posts.

**Figure 18.** Corner posts with coupling profile



- Ensure that the sealing tape supplied is fixed to one of the two sections, before moving the sections against each other .

**Figure 19.** Fixing sealing tape to the corner posts



- Link the sections by connecting the pre-mounted corner posts with bolts and nuts (M6).

**Figure 20.** Connecting the corner posts



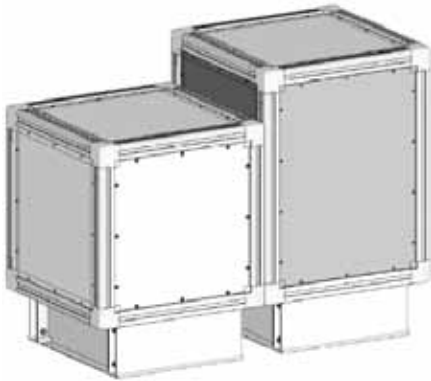
- If there are more than two sections, repeat the procedure above. For an outdoor installation all external joints should be sealed.

For an outdoor installation the plastic roof cover must be finished as described in chapter 8.

**NOTE: If the AHU needs to comply with air tightness class L1 (LuKa C), the internal connection strip joints and/or profiles should also be sealed.**

### 5.3. Connecting Casings of Different Height

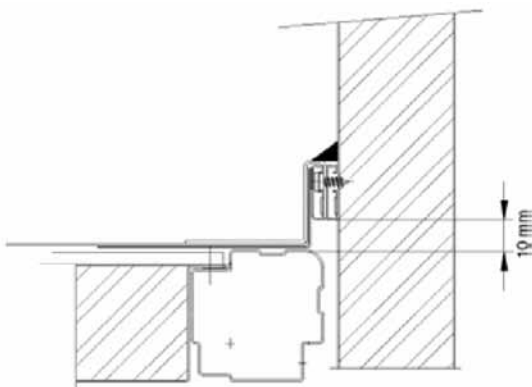
**Figure 21.** Unit of different height



After the internal connection of the sections an indoor installation requires no further finish (see chapter 5.2). For the external finish of an outdoor installation use following method:

- Check if the cover strip has been applied at the correct height on the projecting section.
- Fix the plastic finish layer to cover strip above with the screws provided.
- Add a second cover strip over these screws.
- Position the sections against each other so that the corner posts of both casings are touching and first connect the sections internally, as described in chapter 5.2.
- Attach the projecting strip of the plastic roof foil over the connection profile of the lower casing section with a blow dryer.

**Figure 22.** Roof finish, units of differing height - 1

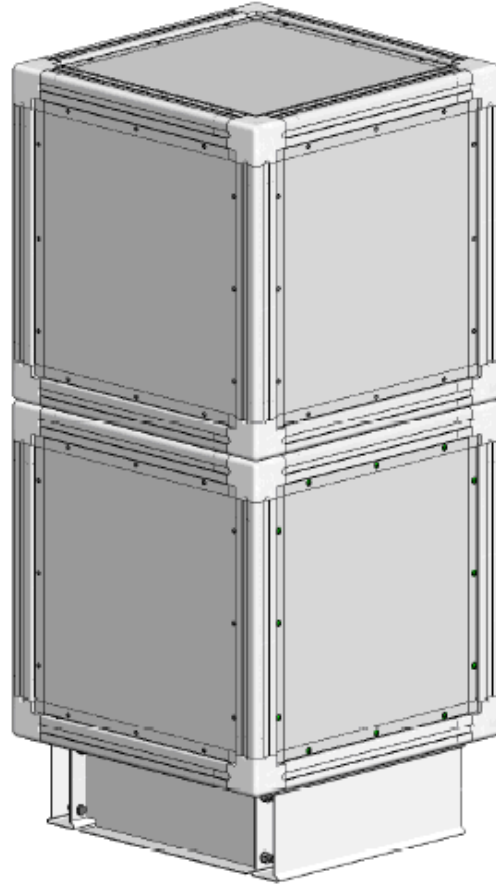


**NOTE: All resulting external joints should be sealed.**

## 6. STACKED CASING SECTIONS

### 6.1 Unit without Intermediate Base Frame (Equal Width)

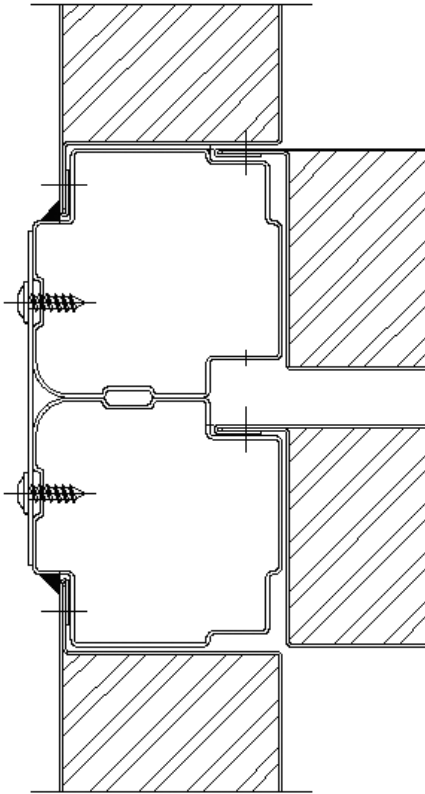
**Figure 23.** Unit without intermediate base frame



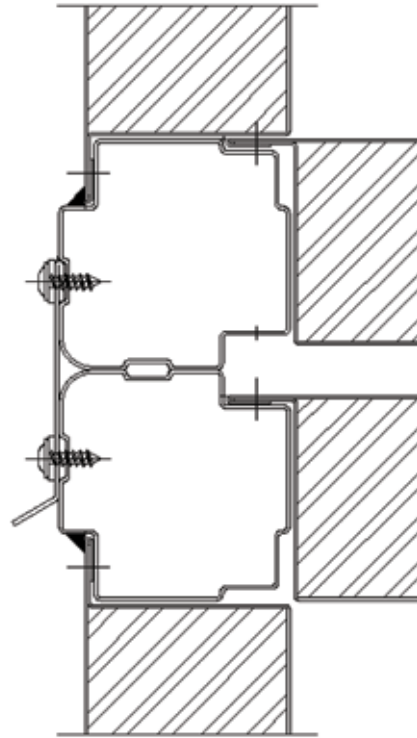
#### Indoor Installation

- Position the casing sections on top of one another so that the corner posts are in the same plane.
- Mount the profiles supplied as described below. For sections of equal length, these profiles should be mounted all round the unit.
- For shorter or longer upper sections the ends need no further finish.

**Figure 24.** Mounting profile, indoor location, unit without intermediate base frame



**Figure 25.** Mounting profile, outdoor location, unit without intermediate base frame

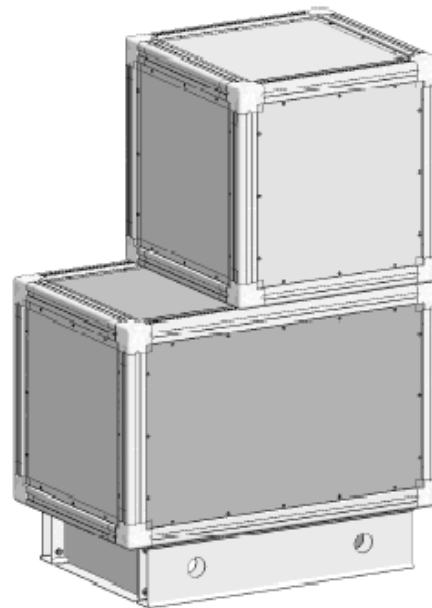


- If the top section is shorter than the bottom section, the ends should be finished as described below.

### Outdoor Installation

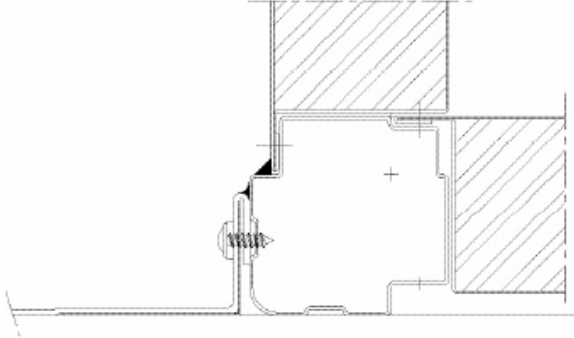
- Position the casing sections on top of one another so that the corner posts are in the same plane.
- Mount the profiles supplied as described below. For sections of equal length, mount the profiles all round the unit.

**Figure 26.** Unit with shorter top section without intermediate base frame



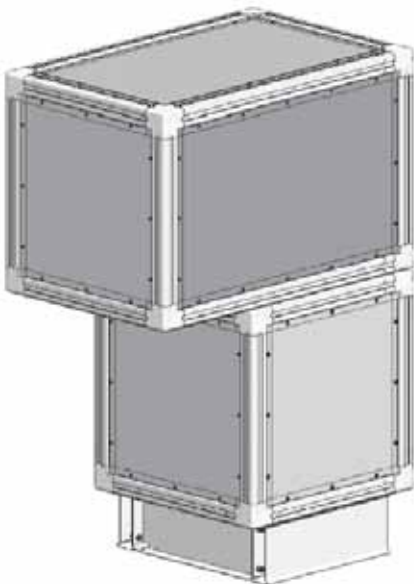


**Figure 27.** roof finish, unit with shorter top section without intermediate base frame



- A longer top section needs no further finish at the ends.

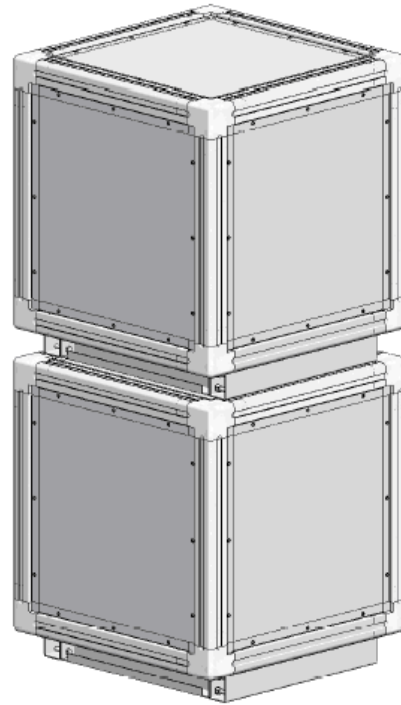
**Figure 28.** Unit with longer top section without intermediate base frame



**NOTE:** For outdoor installation seal all joints resulting from the mounted profiles. This applies to both corner and butt joints.

## **6.2. Unit with Intermediate Base Frame (Equal Width)**

**Figure 29.** Unit with intermediate base frame



### **Indoor Installation**

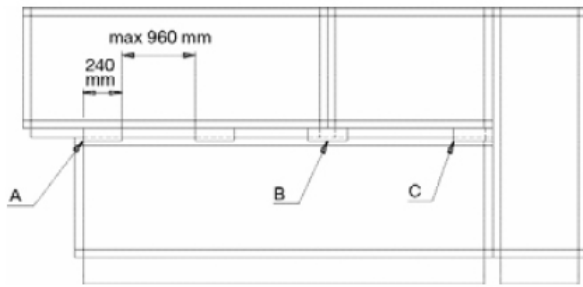
For indoor installation connection profiles of 240 mm length are supplied.

- Position the casings on top of one another so that the corner posts are in the same plane. The base frame of the top section should be slightly back compared to the bottom casing section.

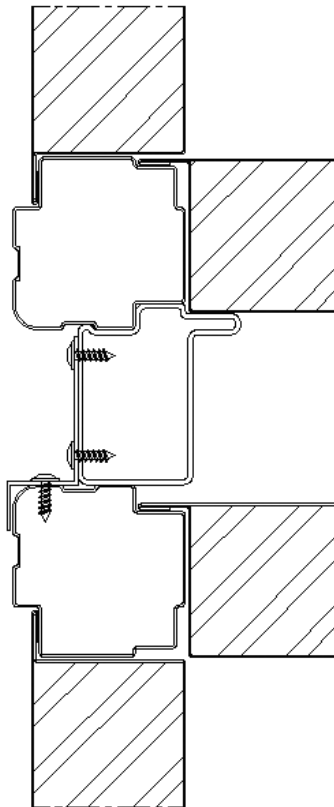
If stacking units in an indoor installation the connection profiles should be placed between the different unit sections. Use the following assembly method:

- Install a connection profile to the end of the casing section, stopping at the module line (A).
- Install a connection profile at the joint (B).
- Install a connection profile against the adjacent section (C).

**Figure 30-1.** Stacking, indoor location with intermediate base frame



**Figure 30-2.** Fixing profile, indoor location with intermediate base frame



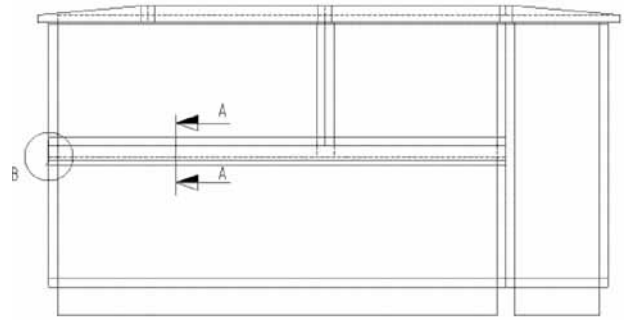
There is no need for a connection profile at the ends of the unit.

**NOTE:** The maximum distance between two connection profiles is 960 mm. For greater distances connection profiles should be installed on the operation side and non-operation side.

**Outdoor Installation**

For an outdoor installation, the connection profiles supplied need to be cut to the correct length. These profiles should be mounted over the entire unit length and width.

**Figure 31.** Stacking, outside location

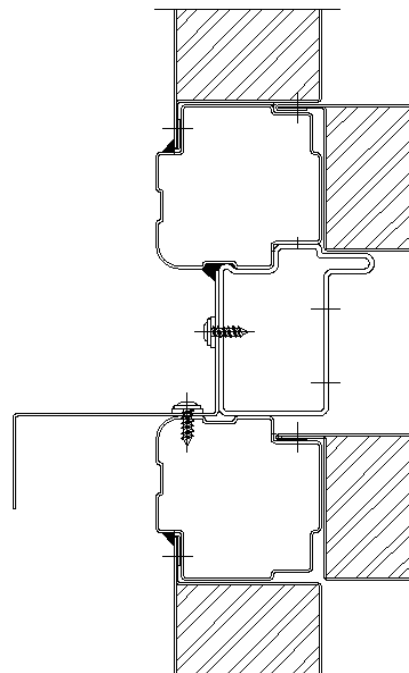


Bear in mind that different connection profiles are used for the length and width directions of the cabinet.

- Length direction: Cut the connection profile supplied to the correct length and mount it as described below.

**Figure 32.** Fixing profile, length direction, unit with intermediate base frame

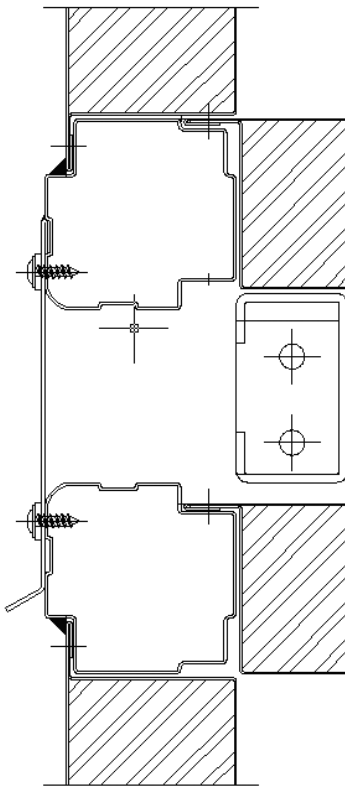
**Cross section of length direction (A-A)**



- Width direction: Cut the supplied connection profile to the correct length and mount it in the way given below.

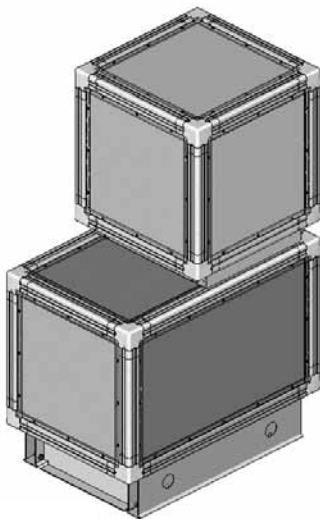
**Figure 33.** Fixing profile, width direction, unit with intermediate base frame

**View of width direction, equal casing length (B)**



- If the top section is shorter than the bottom section, the unit ends should be finished as described below.

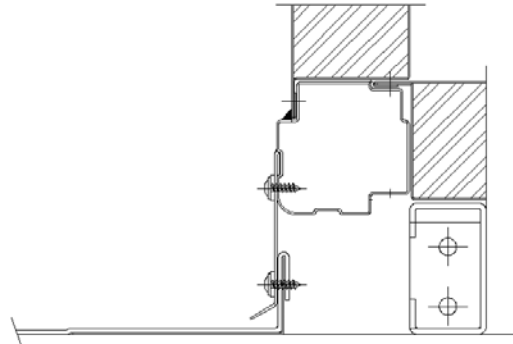
**Figure 34.** Unit with shorter top section with intermediate base frame



- Cut the connection profile supplied to the correct length and mount it to the unit ends as described below

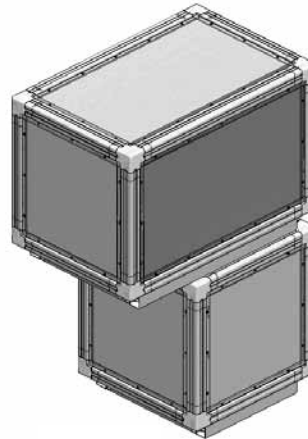
**View of width direction if the top section is shorter**

**Figure 35.** Roof finish, shorter top section with intermediate base frame



- A longer top section needs no further finish at the top.

**Figure 36.** Unit with longer top section with intermediate base frame



**NOTE:** For an outdoor installation, seal all joints resulting from the mounted profiles. This applies to both corner and butt joints.

**6.3. Unit with Different Widths**

For units with different widths, there are four different situations. For an indoor installation the method described below applies to all situations.

**Indoor Installation**

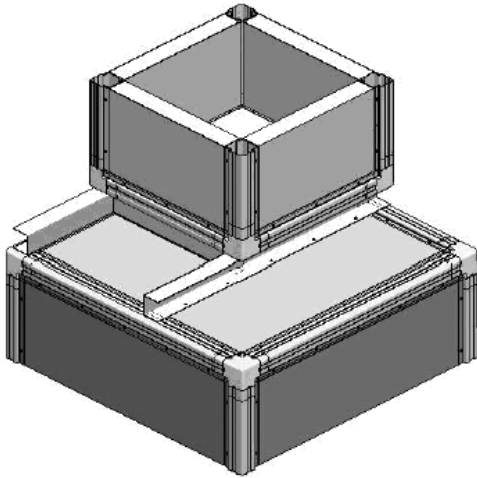
The top section includes a projecting cross beam that is effectively as wide as the bottom section.

- Check that the cover strip at the ends of the bottom section is installed in the correct place.
- Position the top section as indicated in the dimensional drawing.
- Screw the projecting cross beam of the top section to the corner posts of the bottom section.



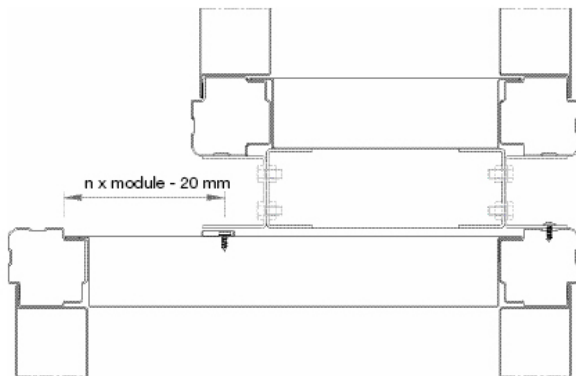
### Cross section of width direction

**Figure 37.** - Width direction view, unit of unequal width



### Cross section of length direction

**Figure 38.** - Length direction view, unit of unequal width



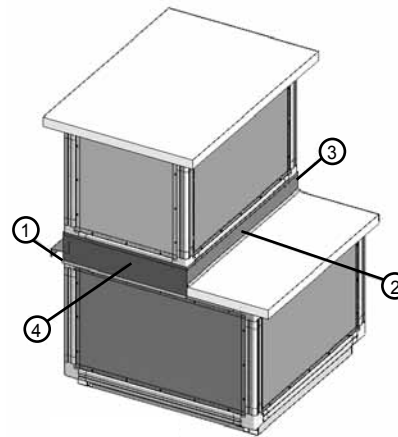
### Outdoor Installation

The top section includes a projecting cross beam that is effectively as wide as the bottom section. For an outdoor installation the connection profiles supplied need to be cut to the correct length. These profiles should be mounted over the entire unit length and width.

- Position the top section as indicated in the dimensional drawing.

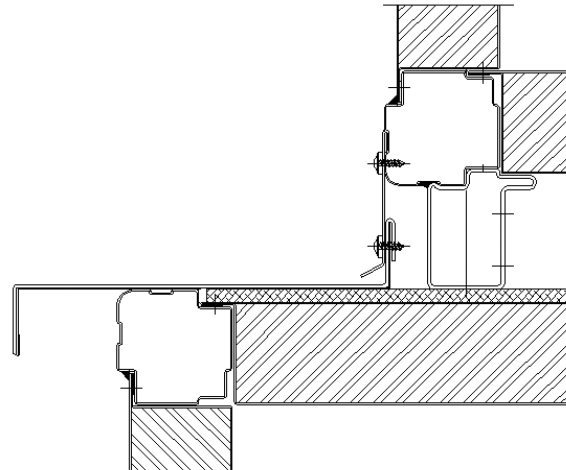
The position of the top section can be as described in one of the four situations below:

**Figure 39.** - Unit of unequal width - situation A



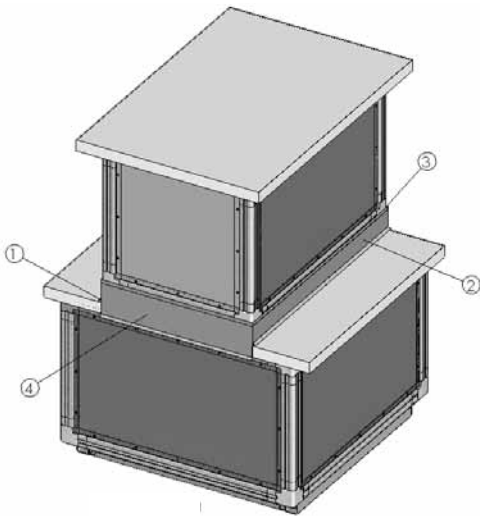
- Side 1: Cut the connection profile to the correct length and mount it on the correct side (see Fig 36).
- Side 2: Cut the connection profile to the correct length and mount it on the correct side as described below.

**Figure 40.** - Roof finish, situation A, side 2



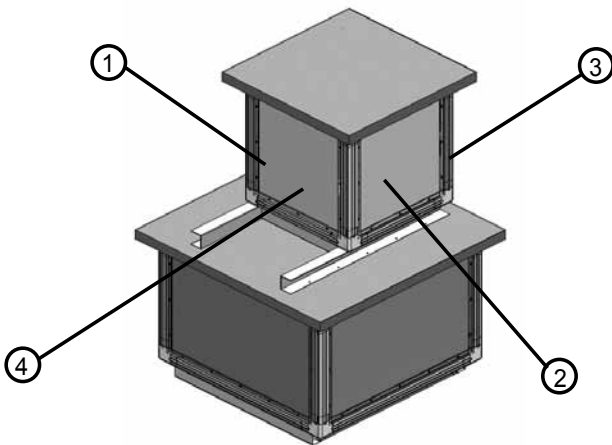
- Side 3 and 4: Cut the connection profiles to the correct length and mount them on the correct sides (see Fig 37).

**Figure 41.** - Unit of unequal width - situation B



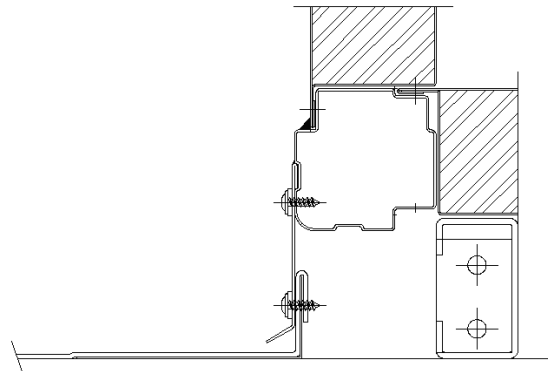
- Side 1 and 2: Cut the connection profiles to the correct length and mount them on the correct sides (see Fig 44).
- Side 3 and 4: Cut the connection profiles to the correct length and mount them on the correct sides (see Fig 37).

**Figure 42.** - Unit of unequal width - situation C



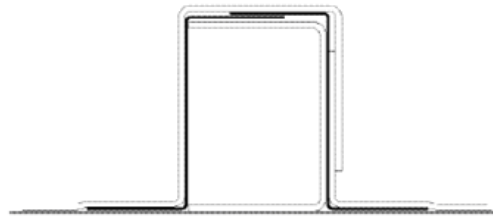
- Side 1: Cut the connection profile to the correct length and mount it on the correct side (see Fig 36).
- Side 2: Cut the connection profile to the correct length and mount it on the correct side (see Fig 44).
- Side 3: Cut the connection profile to the correct length and mount it on the correct side (see Fig 37).
- Side 4: Cut the connection profile to the correct length and mount it on the correct side as described below.

**Figure 43.** - Roof finish, situation C, side 4

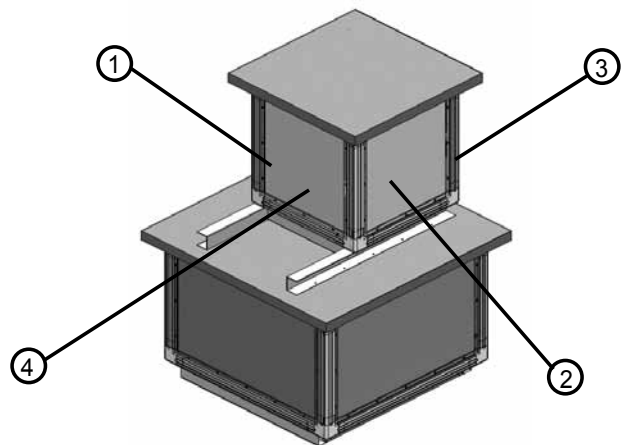


Mount Z-profiles over the projecting cross beam of the top section as described below. The plastic roof foil of the bottom casing section can be applied over these profiles.

**Figure 44.** - Roof finish, projecting cross beam



**Figure 45.** - Unit of unequal width - situation D



- Side 1 and 2: Cut the connection profiles to the correct length and mount them on the correct side (see Fig 44).
- Side 3: Cut the connection profile to the correct length and mount it on the correct side (see Fig 37).
- Side 4: Cut the connection profile to the correct length and mount it on the correct side (see Fig 47).
- Mount Z-profiles over the projecting cross beam of the top section as shown in Fig. 48 of this chapter. The plastic roof foil of the bottom casing section can be applied over these profiles.

**7. FRESH AIR INLET HOOD**

The fresh air inlet hood may be supplied loose with the AHU. In this case the air inlet hood must be attached in the correct position as follows:

- Install the inlet hood with the screws supplied in the correct location.
- The bottom wire grille should then be attached to the corner post.

**Figure 46.** - Fresh air inlet hood



**NOTE:** The connection between the outdoor air suction grille and the corner post should be sealed.

**8. ROOF COVER**

For outdoor installations the roof cover should be provided with a finish. If the casing section has a flat top use one of the following two methods:

**Method 1**

- Shorten the plastic roof foil strip supplied to the correct length. Ensure that the strip projects enough to attach it to the side of the roof edge with a blow dryer.
- Ensure that the roof cover already attached to the two casing sections to be connected is clean and dust-free.

- Attach the roof cover strip with a blow dryer over the entire length of the joint up to the roof edge.
- Remove any excess roof foil up to the underside of the roof edge.

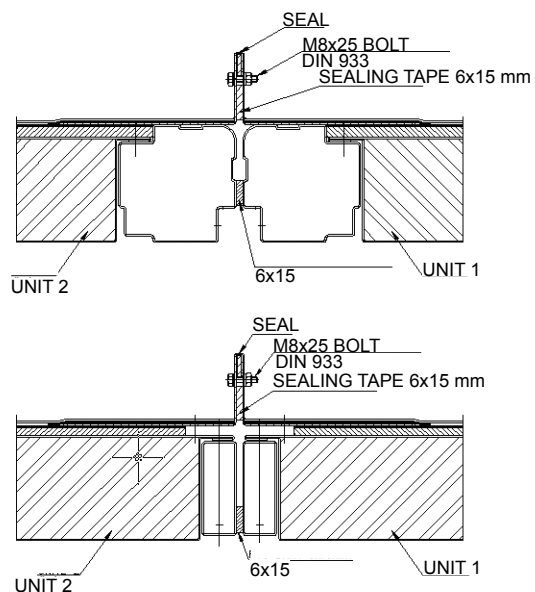
**Figure 47.** - Roof finish. method 1



**Method 2**

- Fix sealing tape to the connection profiles. Drill 160 mm holes with a 10 mm diameter through the connection profiles. Be sure to remove the drill shavings after drilling.
- Attach the casing sections to each other using bolts and nuts (M8).
- Seal the seam on the top of the connecting profiles.

**Figure 48.** - Roof finish. method 2



## 9. CHECKLIST OF START-UP CHECK POINTS

### 9.1. Checklist of Start-up Check Points

The table below shows a general overview of the planning required to facilitate the installation of the AHU. The following pages give a more detailed description of the individual components.

***!CAUTION!***

Before starting up the AHU ensure that the components have the correct connection voltage and connect them in accordance with the regulations. The doors and access covers must be closed and the AHU must be earthed.

<b>Start-up check points</b>			
<b>FUNCTION</b>	<b>COMPONENTS</b>	<b>CHECK POINTS</b>	<b>Start-up</b>
<b>General</b>			
<b>Indoor installation</b>	Internal and external panels	Damage	
<b>Outdoor installation</b>	Internal and external panels	Damage	
	Joints	Cracks	
	Doors/access covers	Must be closed before start-up	
	Flexible connections	Correct installation	
	Earthing	Correct earthing in accordance with regulations	
<b>Dampers</b>		Correct operation	
	Actuators	Correct operation	
<b>Filters</b>		Correct filter type	
		Are the filters correctly installed	
	Pressure differential gauge	Correct operation	
	Pressure differential switch	Correct operation/set-up	
<b>Heaters</b>	Hot-water coil	Correct connections	
		Leakage	
		Operation of frost protection thermostat	
	Electric heater	Correct connections/safety devices	
	Steam heater	Correct connections/safety devices	
		Leakage	
<b>Coolers</b>	Cold-water coil	Correct connections	
		Leakage	
	Droplet eliminator	Correct alignment	
	Drain trap	Correct connection	
<b>Heat recovery wheel</b>	Rotor	Direction of rotation	
	Sealing	Correct installation	
	Drive	Motor/belt/rotation control	
	Controller	Correct set-up	
<b>Plate heat exchanger</b>	Damper (if used)	Correct operation	
	Actuator (if used)	Correct operation	
	Drain trap	Correct connection	
	Droplet eliminator	Correct alignment	

<b>FUNCTION</b>	<b>COMPONENTS</b>	<b>CHECK POINTS</b>	<b>Start-up</b>
<b>Direct steam humidification</b>	Connections and fittings	Leakage	
	Actuator/valve	Check connection and operation	
<b>Electrical steam humidification</b>	Connections and fittings	Leakage/operation	
	Electrical components	Check connection voltage	
		Check connection and operation	
<b>Water humidifiers</b>	Spray humidifier	See documentation supplied	
	Infrasonic humidifier	See documentation supplied	
	Wet cell	See documentation supplied	
<b>Fan</b>	Transport protection brackets	Remove	
	Fan housing and fan compartment	Remove obstacles and loose debris from the fan and fan compartment	
	Motor	Check connection voltage	
		Check connection	
		Check all phases	
	Drive belts	Check tension	
	Flexible connections	Correct installation	
	Operating switch	Check connection	
	Operating switch	Ensure switch is locked off during checks	
	Pressure switch	Operation	
<b>Sound attenuator</b>		Damage to splitters	
<b>Lighting</b>	Lamp	Check connection voltage	
	Switch	Check connection	

## 10. START-UP INSTRUCTIONS

### 10.1. Casing

The label with the unit data, such as order number, position number etc. is usually located on the access cover or door of the fan compartment.

<b>Carrier</b>		<b>CE</b>
<b>AIR HANDLING UNIT</b>		
Type	39HQ1010	
Order No.	MH00770	
Location	Ameliyathane	
Volume (m3/h) / Pressure (Pa)	23000 / 1197	
Prod. Date	2005	
 GOSB - Gebze Organize Sanayi Bölgesi Sahabettin Biglasi Caddesi 41490 Gebze - KOCAELI Tel : 444 0 128 Fax : (0262) 648 60 08		
		 SERI NO: XXXXXXXXXXXXXXXX

### 10.2. Casing Panels

Check the AHU panels for any damage. Any dirt or stains must be removed from the surface to prevent possible long-term damage. Building debris left on the roof must be removed. Dirt can be removed with water and a mild house-hold soap solution. Damage can be repaired by thoroughly cleaning the affected surface, then treat and paint as necessary. If applicable check the sealing joints and repair if required.

### 10.3 Doors and Access Covers

Check the operation of door handles, locks and movement of the hinges. For outside installation of the AHU check the storm cord.

#### **!CAUTION!**

**Doors and access covers must always be closed before starting the unit.**

### 10.4. Flexible Connections

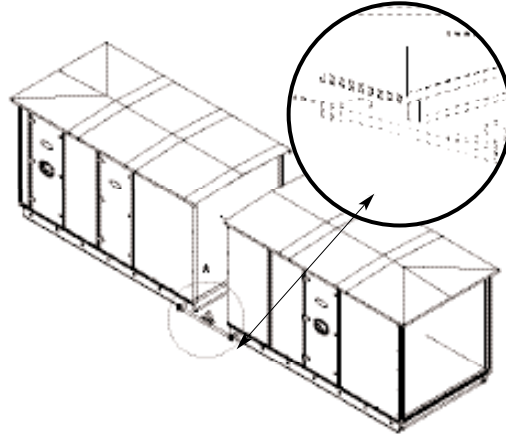
Check that all flexible connections are attached to the AHU. If necessary, tighten loose screws.

### 10.5. Earthing

Ensure that the AHU has been earthed correctly and in accordance with local regulations. A label on the support frame indicates where the unit should be earthed.

### 10.6. AHU Installation and Connection

The floor in the room where the AHU is installed must be water-tight and flat to prevent connection problems. Before the units are placed against or on top of each other, the sealing tape supplied must be attached between the casing sections.



**Figure 49.** - Pulling the sections with pull ropes

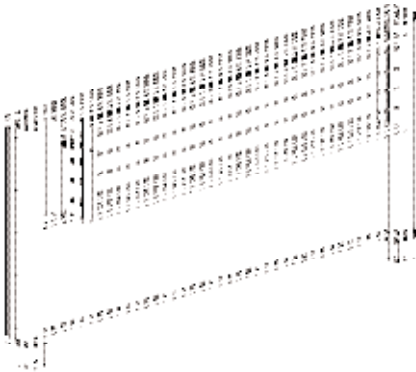
Place the casing sections as close as possible together before assembly. Pull the casing sections towards each other by placing the lifting bars first in one and then in the other casing section. Then pull both parts towards each other using pull ropes.

The casing sections are connected with the frames and fixing elements supplied. If the AHU is installed outside, the roof connecting plate provided must be installed on the roof and sealed.



**10.7. Dampers**

- Check if the actuator motor is installed in accordance with the supplier’s instructions.
- Check if the correct angle has been set.
- Check if the dampers close properly.
- Check if the damper can open to the required angle.
- Check operation after the power has been restored-following a power cut. Some dampers must be open, others must be closed.

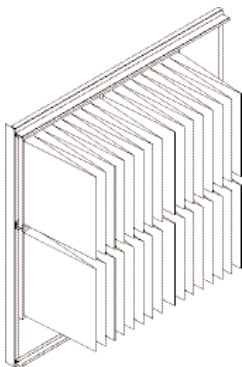


**Figure 50.** - Manual operation

**Figure 51.** - Actuator-assisted operation

**10.8. Air Filters**

- Check if the correct filters have been installed.
- Check if the filters have been installed correctly.
- Absolute filters are supplied separately, to prevent contamination during transport and start-up. Insert the absolute filters only after the unit has been cleaned.
- Set pressure switches or filter indicators, if used.
- Close the inspection door.
- Filter installation details shown in Appendix 2.
- According to the filter and application type number of filters usual with listed in Appendix 3.



**Figure 52.**

**10.9. Heaters**

**10.9.1. General**

- Check connections in accordance with the dimensional drawing.

- Check connections for leakage.
- Ensure that the heater can supply heat to prevent frost formation when the fan is started.
- Caution:** When the coils are drained, no water must remain in the circuits to prevent freezing at temperatures below zero.

**10.9.2. Electric Heaters**

- Ensure that the heater has been connected in accordance with the instructions of the supplier. The diagram is located on the inside of the connection module.
- Check the heater current.
- Check if the safety devices shown in the wiring diagram have been installed.
- Check if the heater has been earthed in accordance with local instructions.
- The electric heater may only be switched on if the minimum specified air flow rate across the heater exists.
- The electric heater must be switched off at least 5 minutes before the AHU is switched off.
- Ensure that no objects have been left in the heater section.
- The following warning pictograms are attached to the panel: electrical voltage and hot surface.



**10.9.3. Steam Heaters**

- Steam heaters have surface temperatures above 100°C. Steam supply must be checked by qualified personnel.
- The steam heater may only be switched on if the minimum specified air flow rate exists across the heater.
- Ensure that no objects have been left in the heater section.
- The steam heater must be switched off at least 5 minutes before the AHU is switched off.
- The following warning pictogram is attached to the panel: hot surface.



### 10.10. Siphon

It is advised to use siphon to have a constant water drain at all the outlets of the cooling coil, humidifier and other wet areas of the Air Handling Units.

Siphon application is very important not to have air suction or leakage from these outlets and also draining the water without overflow which may move inside the unit.

For the sizing of the siphon, static pressure of the location must be considered.

For the positive and negative pressures it is mandatory to use different siphons (See Figure 53 and 54).

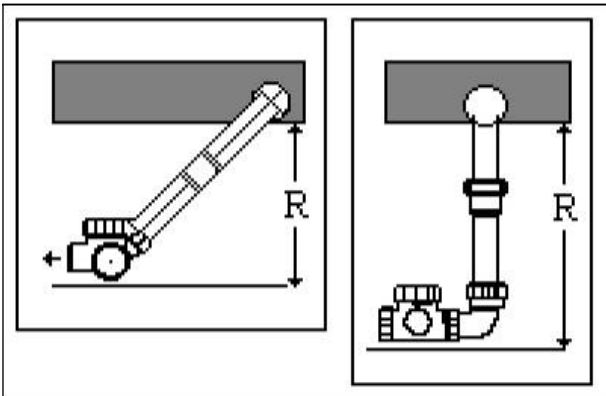


Figure 53. - Negative pressure siphone

$$R = (P/10) - 30$$

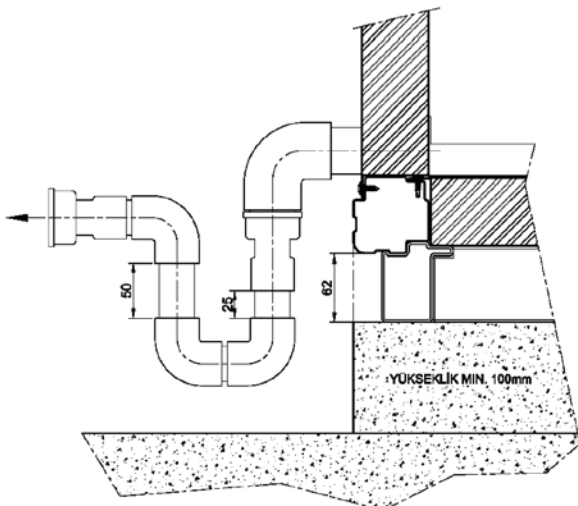


Figure 54. - Positive pressure siphone

Before start up the unit fill, the positive pressure siphon with water.

Negative pressure siphon may only be applicable for negative drainage. Negative pressure siphon can be set up as in Figure 53. In Figure 55, parts and montage order of siphon are given.

The ball inside the negative pressure siphon provides drained water fill the siphon by preventing air suction.

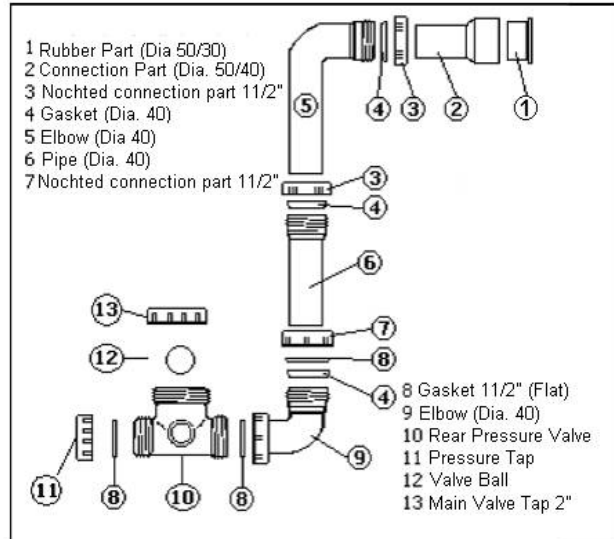


Figure 55.

Water drain direction marked with an arrow on the negative pressure siphon.

Application types according to the pressure and siphon types are shown in Figure 56.

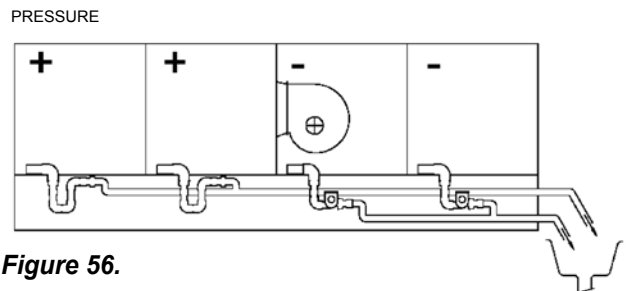


Figure 56.

Air Handling Unit base frame height can either be 62 mm. or 160 mm. There is no need to make an extra base for the AHUs with 160 mm. base frame.

For 62 mm. base frames, a base shown in Figure 54 is necessary. The constructed base should be leveled and balanced

For AHU with NPU profile concrete base requirement and height must be checked and AHU installation area must be prepared according to the above explanations.

### 10.11. Coolers

-Check the connections in accordance with the dimensional drawing.

-Control the connections for leaks.

-Check drain trap. If Alarko Carrier standard siphon trap is used, check it has been correctly installed. Check if siphon cover and ball have been correctly installed.

-Check if the droplet eliminator after the cooler has been correctly installed.

-Check if fins have been bent during transport. Correctly straighten the fins.



-If a cooling coil is incorporated, after several days of cooling operation check the condensate drain and operation of the plastic siphon. If necessary clean the siphon.

### **10.12. Heat Recovery Wheel**

-Check that the wheel is rotating in the correct direction. This is indicated by an arrow on the casing.

-Check if the wheel seals are fitting correctly.

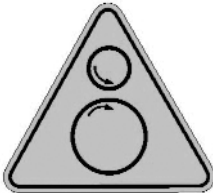
-Check if belt tension is correct.

-Check if the motor and the rotation monitor have been correctly connected.

-Check if the controller has been correctly connected and set in accordance with the instructions of the supplier.

-Check if the rotor speed has been set correctly.

-The following warning pictogram is attached to the panel: rotating parts.



### **10.13. Plate Heat Exchanger**

Used if dampers are installed.

-Check if the actuator motor has been installed in accordance with the instructions of the supplier.

-Check if the correct angle has been set.

-Check if the dampers close correctly.

-Check if the damper can open to the correct position.

-Check operation after the power has been restored following a power cut. Some dampers must be open, others must be closed.

-Check if fins have been bent during transport. Correctly straighten the fins.

-Check if the siphon has been correctly installed. Check if siphon cover and ball have been correctly installed.

### **10.14. Direct Steam Humidification**

-Check the fixing of the steam pipe.

-Check the steam supply and condensate drain pipes.

-For longer pipes install an extra condensate pan in accordance with the instructions of the supplier.

-Check if the pollution trap has been installed.

-The condensate drain should not be without pressure in accordance with the manufacturer's instructions. Refer to the instructions of the supplier.

-If the AHU has negative pressure, install a special siphon ahead of the condensate drain.

-Before starting up the steam humidifier steam must be introduced slowly into the system to bring the humidifier to the correct operating temperature. Once the condensate pipe has reached the operating temperature, start the actuator motor electrically or pneumatically and set the desired humidity level. Refer to the instructions of the supplier.

-A few days after starting up the unit clean the sieve of the pollution trap and check the condensate drain. For casings with negative pressure the operation of the negative pressure system must be controlled with the check valve.



-The following warning pictogram is attached to the panel: hot surface.



### **10.15. Electrical Steam Humidification**

-Check the fixing of the steam generator.

-Check the steam supply and condensate drain pipes.

-The condensate drain should not be without pressure in accordance with the manufacturer's instructions. Refer to the instructions of the supplier.

-If the AHU has negative pressure, install a special siphon ahead of the condensate drain.

-Check the voltage and measure the total current draw.



## **10.16. Water Humidifiers**

### **10.16.1. Spray Humidifiers**

Refer to the instructions supplied by the supplier.

### **10.16.2. Infrasonic Humidifier**

-Carefully read the instructions from the supplier. The following points need extra attention.

-Check if connection voltage agrees with the unit voltage.

-Connect the unit according to the diagram supplied.

-Check that the drain is correctly connected.

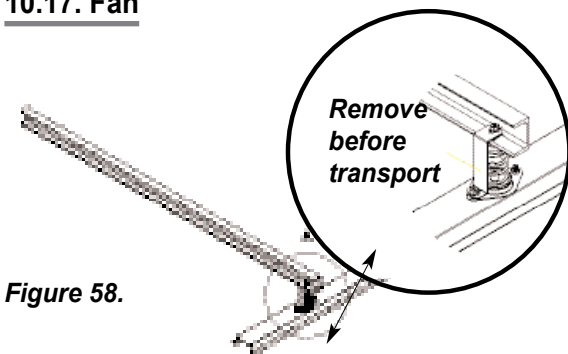
-Check the connections of the high-pressure pipes. After starting the unit ensure that the pipes do not rub against anything.

-Check if the spray jets work correctly.

-Check the operation of the pressostats and the pressure.

-Check the water quality.

## **10.17. Fan**



**Figure 58.**

-Remove the transport brackets. This is indicated by a label on the door.

- If fan-motor assembly is constructed with Al profiles; remove the square nuts in Al profile channels, after dismantling Z brackets.

-Check if the fan can move freely without obstructing the frame, flexible connection or wiring.

-Check the direction of the connection according to the pulley position. If required turn the connection before connecting the wiring.

-Check the connection voltage.

-Check and/or connect the motor in accordance with local instructions and the data of the supplier.

-Check the direction of rotation of the impeller. The direction is indicated on the casing by an arrow.

-Separately measure the current draw of the electric motor for all phases. The current draw of all phases

must be approximately the same and agree with the data on the name plate. Set the motor protection device to the nominal value.

-The data for the belt type, belt tension, number of belts, size and type of pulley is indicated on a label attached to the fan housing.

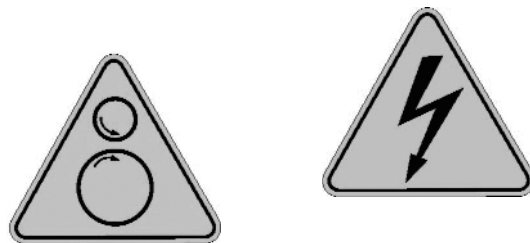
-Check if the flexible connection is correctly installed.

-If used check the pressure switch and set the correct pressure.

-Check the operation of the main switch.

**Caution:** While working on the fan the switch has to be locked open.

-The warning pictograms on rotating parts, electrical-voltage and opening doors are attached to the door. The label to remove the transport brackets is located on the floor of the fan section.



### ***!WARNING!***

***Before opening doors, switch off and deenergise the fan, and ensure that it has stopped rotating (minimum of 2 minutes)***

## **10.18. Sound Attenuator**

-Check the splitters for damage.

## **10.19. Lighting**

-Check the connection voltage.

-Check the operation of the switch. The switch must be connected in accordance with local regulations.

## 11. MAINTENANCE CHECKLIST

### 11.1. Checklist for Check Points and Maintenance Intervals

The checklist contains a general overview of the planning that facilitates the inspections and maintenance of the AHU. On the following pages there is a more detailed description of the individual components.

**!WARNING!**

**Remember to deenergise all components and to ensure that the fan has stopped rotating, before the doors and access covers are opened before inspections and maintenance take place.**

<b>Check points and maintenance intervals</b>							
FUNCTION	COMPONENTS	CHECK POINTS	1 month	3 months	6 months	12 months	Depends on supplier and degree of contamination
<b>Casing general</b>							
<b>Indoor installation</b>	Internal and external panels	Contamination and damage					
<b>Outdoor installation</b>	Internal panels						
	External panels						
		Joints					
<b>Doors/access covers</b>	Hinges	Operation of hinges and locks					
	Locks						
	Door seal	Cracks					
	Flexible connections	Cracks					
<b>Dampers</b>	Damper blades	Sealing					
		Bearings					
	Damper controls	Actuator					
<b>Outdoor air intake</b>	Louvre/cowl	Check for blockages					
	Floor, condensate pan (if used) under filter	Contamination					
	Droplet eliminator (if used)						
<b>Filters</b>	Flat filter	Check filter condition pressure drop across filter, and sealing					
	Bag filter						
	Carbon filter						
	Electrostatic filter						
	Pressure differ. gauge	Operation					
	Pressure differ. switch						
<b>Heaters</b>	Hot-water coil	Contamination					
		Leakage					
	Thermostat	Operation					
	Electric heater	Connections					
	Steam heater	Contamination					
		Leakage					

<b>FUNCTION</b>	<b>COMPONENTS</b>	<b>CHECK POINTS</b>	<b>1 month</b>	<b>3 months</b>	<b>6 months</b>	<b>12 months</b>	<b>Depends on supplier and degree of contamination</b>
<b>Coolers</b>	Cold-water coil	Contamination					
		Leakage					
	Condensate pan	Contamination, operation					
	Droplet eliminator						
	Syphon						
<b>Heat recovery wheel</b>	Rotor	Contamination					
	Sealing						
	Drive: motor	Operation					
	Belt	Wear/voltage					
	Electrical components	Operation					
<b>Plate heat exchanger</b>	Fins	Contamination					
	Damper (if used)	Sealing					
		Bearings					
		Servo					
	Condensate pan	Contamination					
	Droplet eliminator						
<b>Direct steam humidification</b>	Connections and fittings	Leakage/operation					
	Servo	Operation					
<b>Electric steam humidification</b>	Connections and fittings	Leakage/operation					
	Electrical components	Operation					
	Boiler	Scaling on electrodes					
<b>Spray humidifier</b>							
<b>Infrasonic humidifier</b>	Pipes	Connections touch					
	Spray banks	Operation					
	Pressostats	Operation/max. pressure					
	Rinse filter	Contamination					
	Operating pressure						
<b>Fan</b>	Bearings (larger types)	Lubrication/wear					
	Impeller	Contamination					
	Motor (larger motors)	Lubrication					
	Belt	Voltage/wear					
	Vibration dampers	Fixings					
	Flexible connections	Cracks					
	Pressure switch	Operation					

## **12. MAINTENANCE AND OPERATING INSTRUCTIONS**

### **12.1. General**

The AHU(s) require little maintenance. The smooth inside and outside finish of the panels makes maintenance very simple.

For dry sections: once a year thoroughly check the inside and outside of the AHU casing. For maintenance of wet sections (coolers and humidifiers) please refer to the airhandling section concerned.

### **12.2. Casing Panels**

#### **12.2.1. Inside Installation**

a) Internal inspection of the casing of double-skin panel and of all dry parts.

Remove contamination with water and a mild household soap solution. Where damage of the paint finish has occurred, if necessary remove rust and touch up with good quality anti-corrosive primer and paint. The outside air intake sections can show signs of corrosion as they contain wet parts and are affected by mist, rain and air pollutants.

b) Outside inspection of the coating.

If damage to the paint treatment has occurred, remove the rust (if necessary), and touch up with good quality anti-corrosive primer and paint.

#### **12.2.2. Outside Installation**

Check the sealed joints of AHUs installed outside and if required seal again with a UV-resistant and paintable kit. Treat damage as for inside installation.

### **12.3. Doors and Access Covers**

Check locks and hinges of all doors and access covers. For outside installation check the storm cord.

### **12.4. Flexible Connections**

Check the flexible connections for damage.

### **12.5. Earthing**

Ensure that the unit is earthed and installed in the correct manner.

### **12.6. Dampers**

All damper hinges are equipped with plastic bearing-bushings, so that no lubrication is required. Remove excess contamination by cleaning it with compressed air. Clean aluminium parts with water and a mild household soap solution. Check adjusting bolts and linkage and if necessary tighten. Ensure that the damper blades run free of the casing and do not touch the flexible connection.

### **12.7. Outside Air Intake**

Especially the outside air intake is contaminated by pollution taken in with the air. The maintenance interval must be observed, as irreparable damage of the panels might otherwise occur. Clean the outside air intake well and repair damage as described in point 10.2.1.

### **12.8. Filters**

The filters must be inspected once a month for excess pollution, pressure loss, damage and seating of the slide-in filters or built-in frames. With slide-in filters ensure that the filters have been correctly positioned and have been pushed well against each other from below. When replacing built-in filters you must ensure that the filter has been pushed well against the sealant and that the clips have been correctly installed. Filters must be replaced at the required intervals. The timing of the replacement depends on the type of filter, quality and the degree of contamination of the air. The pressure loss across the contaminated filter can be measured with a pressure differential gauge. Maintenance instructions of special filters are available on request.

### **12.9. Heaters**

#### **12.9.1. Water, Glycol and Steam Heat Exchangers**

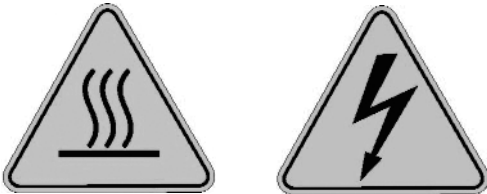
Check the air intake once a year for contamination, and if necessary clean with compressed air against the direction of the air flow or clean the air intake with a vacuum cleaner. Check for leakage. Check the operation of the frost protection thermostat and check the correct control sequence when the thermostat trips. Glycol-charged heat exchangers must be checked annually for the actual percentage of glycol in the water. The following warning pictogram is located on the panel of the steam heat exchanger: hot surface.



### **12.9.2. Electric Heaters**

Check once a year for contamination, and if necessary clean with compressed air. Check the connections in the control box. Check the operation of the thermostat.

The following warning pictograms are located on the panel:electrical voltage and hot surface.



### **12.10. Coolers**

Check once a year for contamination and if necessary clean with compressed air against the direction of the air flow or clean with a vacuum cleaner. The eliminator assembly after the cooler is removable. Check for leakage. Check the fins of the droplet eliminator after the coil. Clean the siphon and check its operation. Check the condensate pan for contamination and clean if necessary.

### **12.11. Heat Recovery Wheel**

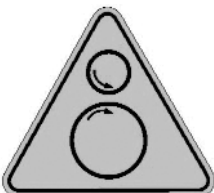
Check the rotor once a year for contamination, and if necessary clean with compressed air. Check the rotor speed and compare it with the design data.

Check the operation of the rotation monitor. Depending on the rotor material the wheel can absorb moisture. When stationary the wheel will become moist on one side and thus heavier. The rotor speed can be set to intermittent in the controller so that the wheel will rotate "x" times per time unit.

The rotor bearings are lubricated for life and do not require maintenance. The drive motor is accessible via an inspection cover.

The V-belt is automatically tensioned by a spring-loaded rocking base on which the motor is installed. New belts expand a lot in the beginning. Check after two days if the belt still has enough tension. After this check the belt tension weekly during the first month and then check it once a month.

For further operation and maintenance details on the heat recovery wheel/controller refer to the documentation provided by the supplier. The following warning pictogram is located on the panel:rotating parts.



### **12.12. Plate Heat Exchanger**

Check the plate heat exchanger once a year for contamination and if necessary clean with compressed air against the direction of the air flow. If dampers are used, follow the instructions in section 10.6.

Check condensate pan for contamination and clean if necessary.

### **12.13. Water Humidification**

#### **12.13.1. Steam Humidifier**

Clean the pollutant trap in the steam supply of the control valve once a year. If a pollutant trap is installed, clean the condensate drain valve and the inside of the condensate pan at the same time.

Inspect the control valve, condensate drain and distribution box twice a year. With steam distribution pipes in negative pressure systems (air-side) there may be excess water present, as the condensate may not drain from the steam distribution pipe. For some brands a special siphon with a check valve is supplied. Check the operation of this valve twice a year.

At the periodical checks of the steam humidifier the casing sections after the humidifier facilitate the checking of the humidification level. Viewed in the direction of the air flow there should not be any steam plume at the end of the steam humidification section.

The electric humidifier capacity is strongly affected by contamination of the steam boiler and the electrodes. This is indicated on the LED. If necessary replace steam boiler.

For further operation and maintenance details on the steam humidifier refer to the documentation provided by the supplier.

The following warning pictograms are located on the panel:hot surface.



#### **12.13.2. Spray Humidifier**

For maintenance details on the spray humidifier refer to the documentation provided by the supplier.



### **12.13.3. Infrasonic Humidifier**

- First carefully read the instructions from the supplier. The following points require extra attention.
- Check the connections of the high-pressure pipes.
- Ensure that the pipes do not rub against anything.
- Check if the spray banks work well.
- Check the operation of the pressostats and the pressure.
- Check the water quality.
- Check the contamination of the rinse filter.
- Check the operating pressure weekly. Higher pressure indicates an increase in contamination.

### **12.14. Fan**

#### **12.14.1. General**

- Caution: The air flow may cause stationary parts to move (even a fan that is switched off)!
- Caution: While working on the fan, the switch has to be locked open.
- The data for the belt type, belt tension, number of belts, size and type of pulley is indicated on a label attached to the fan housing.

#### **12.14.2. Bearings**

The bearings of the smaller fan types cannot be lubricated. If the larger fans are of the relubricated type, then they should be lubricated every six months. For higher temperatures and increased contamination the lubrication interval should be adjusted as required. The standard lubricant is Shell Alvania R3. For higher temperatures and a higher degree of humidity use a lubricant recommended by the supplier.

The electric motors are equipped with roller bearings. Depending on the motor size the bearings are lubricated for life or are equipped with a grease nipple. The lubrication interval and type of lubricant are as above.

#### **12.14.3. Transmission**

After starting up the unit, but also after replacing the belts the belt tension has to be checked within one week and then after two weeks and further tensioned if required. After that check the belt tension and inspect the condition of the belts every three months.

The CORRECT BELT TENSION depends on:

- the belt type;
- power to be transmitted;
- belt velocity.

The belt tension is calculated for each transmission. If the belt tension is too high this can result in bearing wear and vibration, if it is too low this can result in belt slippage and belt wear.

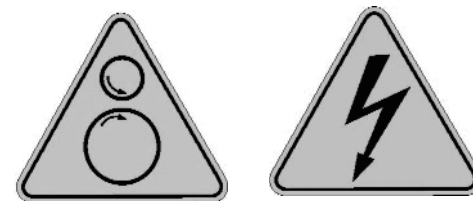
Sequence for installation of new belts:

- Ensure that the pulleys are correctly aligned. If necessary re-align.
- Position all belts loosely on the pulleys, do not pull-tensioned belts over the pulleys.
- Tension the belts and check the tension with a SonicTension Meter.
- Re-check the alignment.

If the fan speed changes or if a motor with different power specifications and/or speed is installed, the manufacturer must be informed. The supplier must re-calculate the bearing load as well as the impeller load. If this is not done, irreparable damage to the fan may incur. The supplier does not accept any responsibility for modifications that have not been approved. See chapter 1.1.



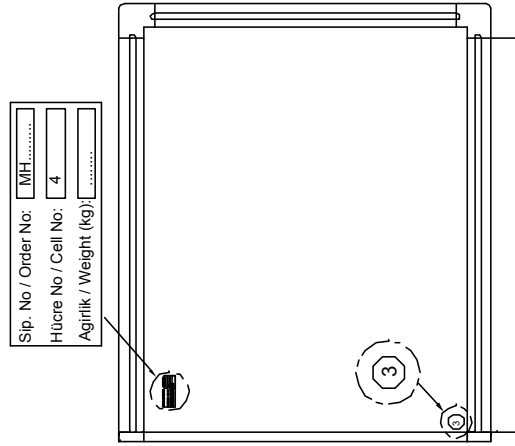
-The warning pictograms indicating rotating parts, electrical voltage and opening of doors are attached to the door.



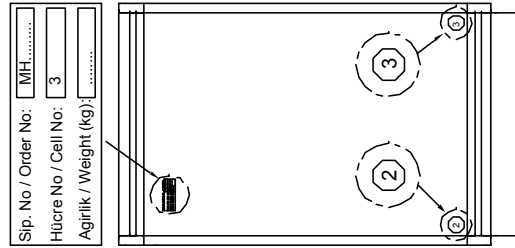
### **12.15. Sound Attenuator**

Under normal conditions the sound dampers are maintenance-free. Nevertheless it is recommended to check the attenuators once a year for possible damage and loose fibres, in order to prevent further contamination of the system.

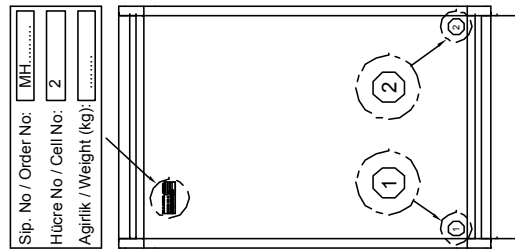
**APPENDIX-1**



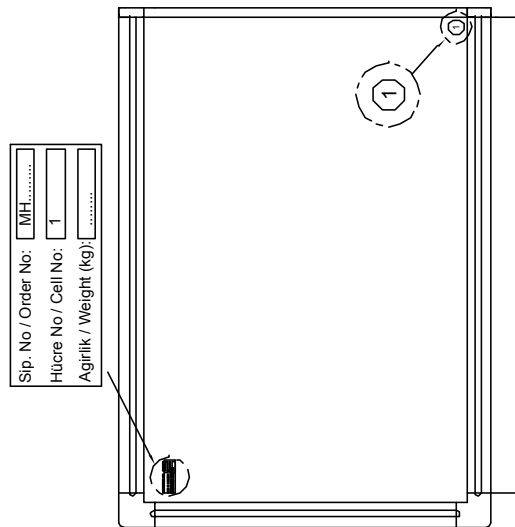
CELL NO: 4



CELL NO: 3



CELL NO: 2

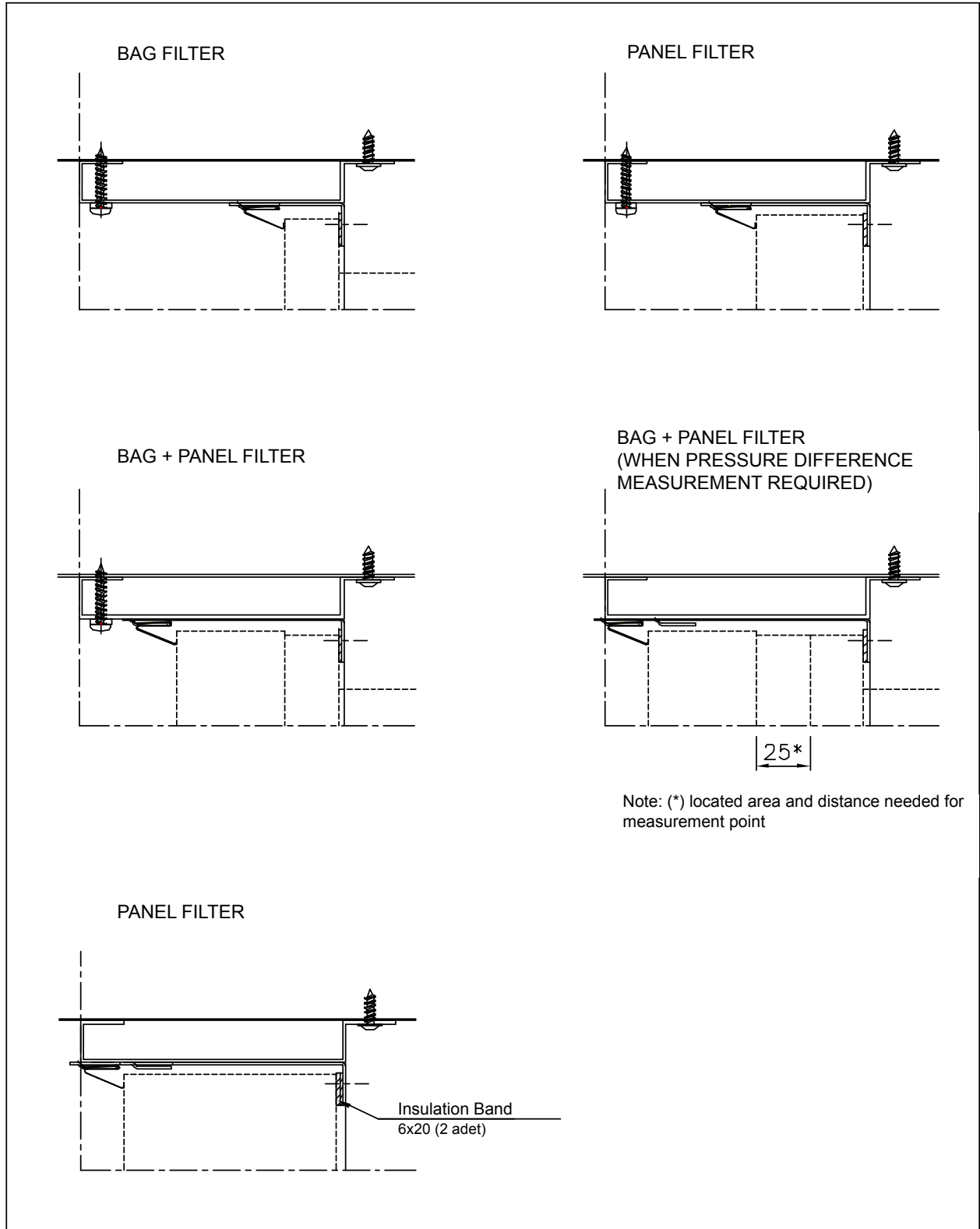


CELL NO: 1

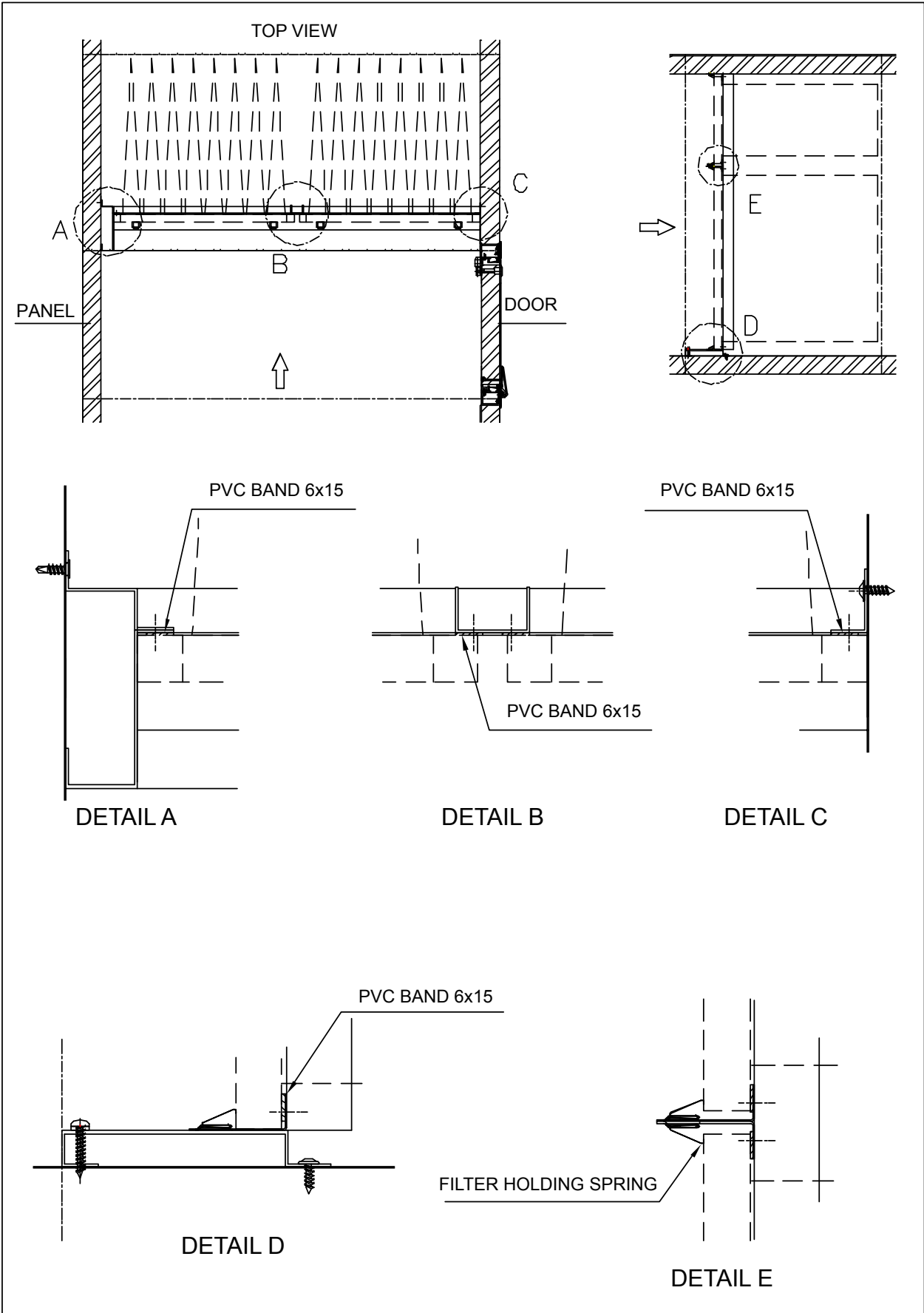


**APPENDIX-2**

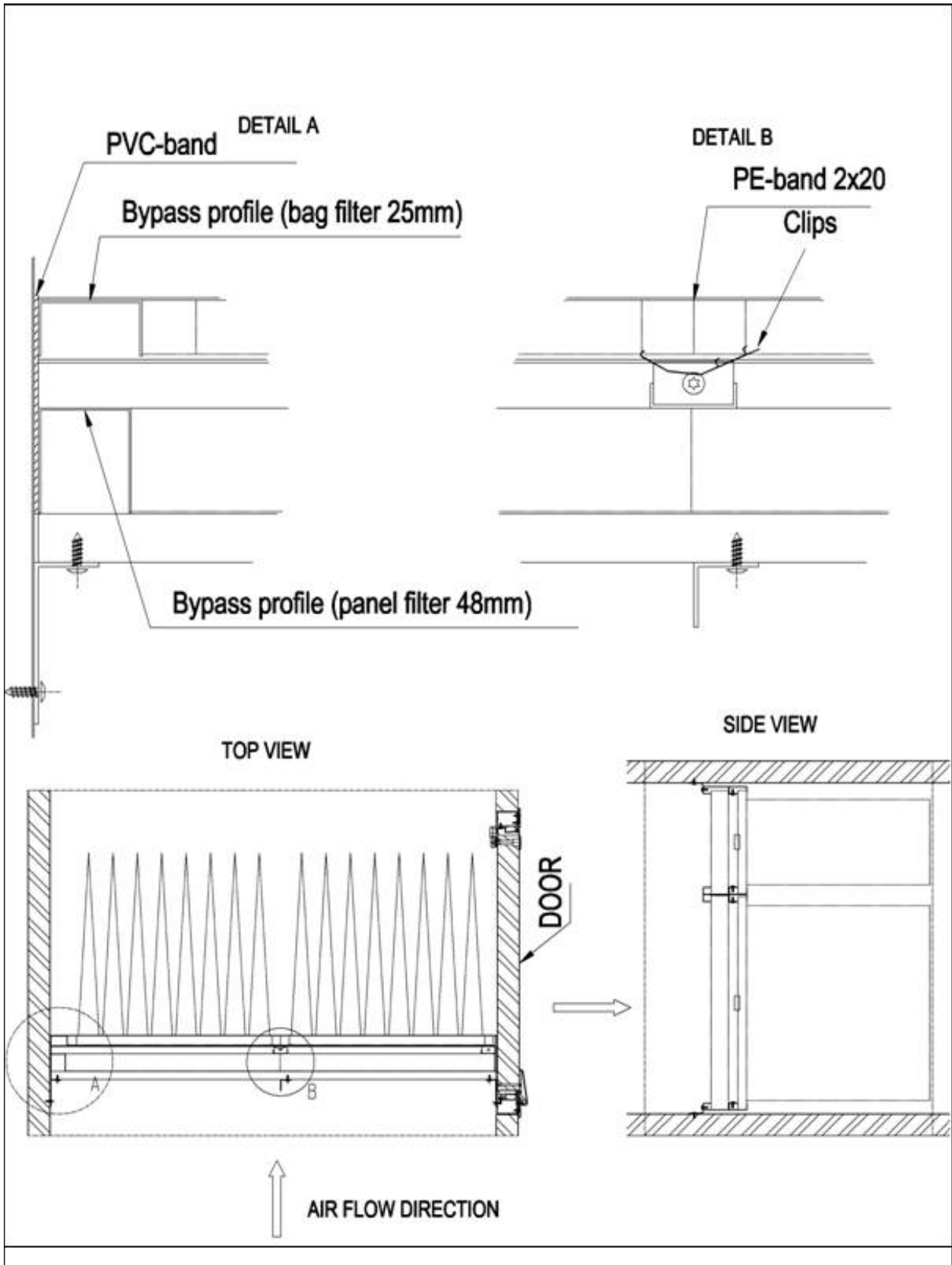
**FRONT WITHDRAWAL FILTERS INSTALLATION DETAIL**



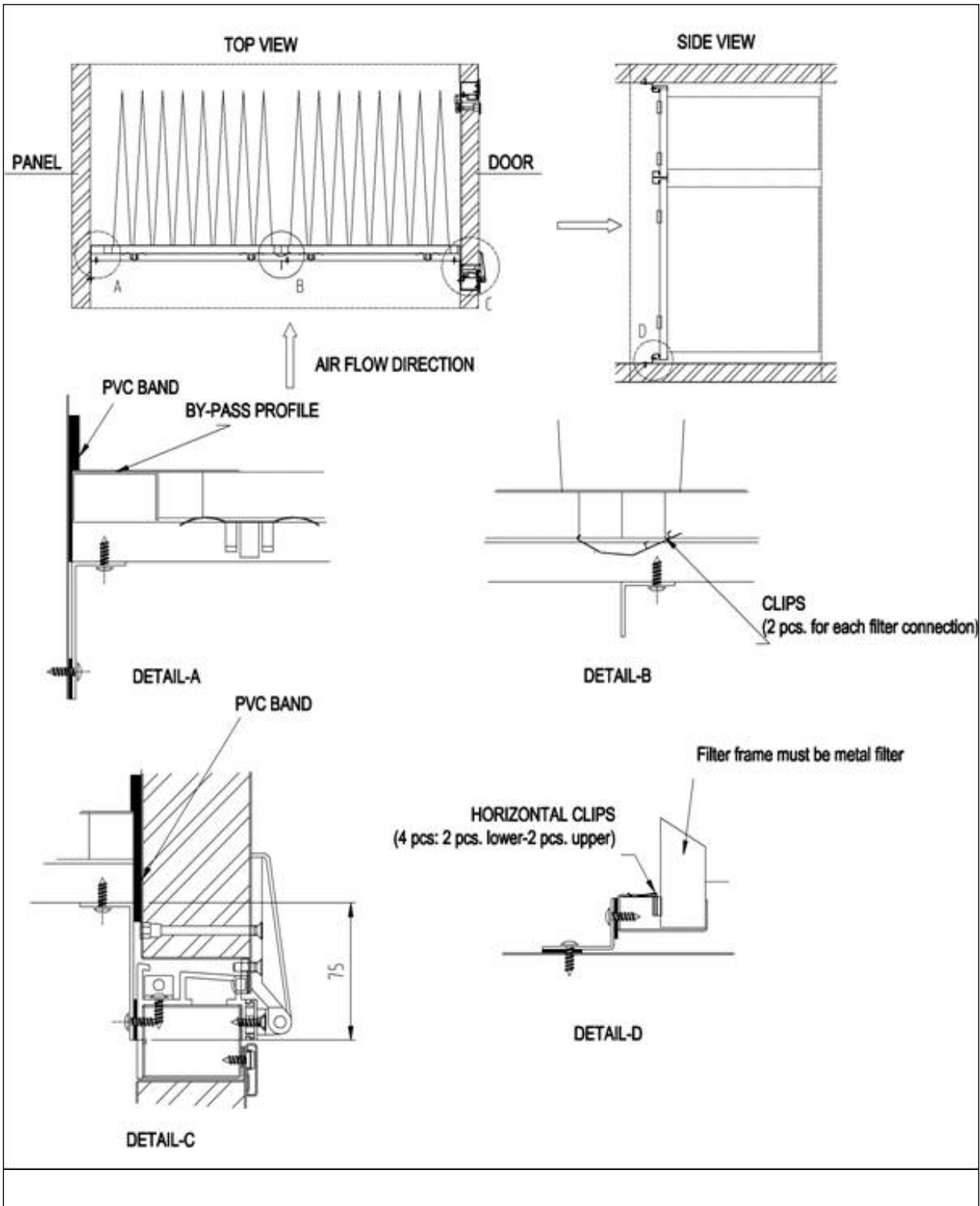
### FRONT WITHDRAWAL FILTERS INSTALLATION DETAIL



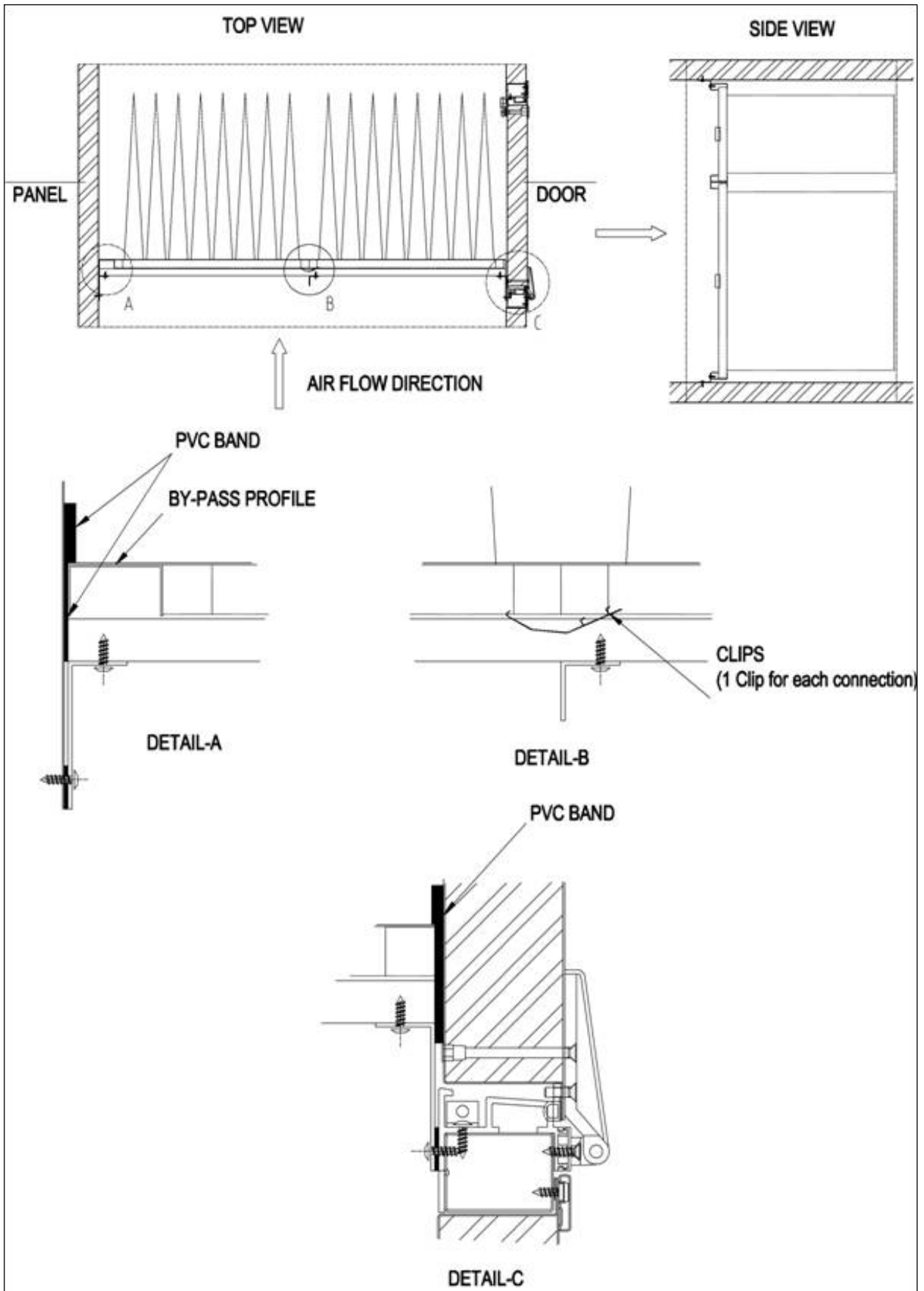
COMBINED SIDE WITHDRAWAL FILTER MONTAGE



F8 – F9 SIDE WITHDRAWAL FILTER MONTAGE



### F7 SIDE WITHDRAWAL FILTER MONTAGE





APPENDIX-3/2 Front Withdrawal Filter

FILTER DIMENSION and QUANTITIES

MODUL	PANEL FILTER						BAG FILTER					
	W	H	292x292	450x300	437x692	592x692	287x287	287x692	437x287	437x692	592x287	592x692
39HQ 4	2,5	4	2	-	-	-	-	-	-	-	-	-
39HQ 4	4	4	2	-	-	2	-	2	-	-	-	-
39HQ 4	6	2	-	-	2	-	-	2	-	-	-	-
39HQ 5	2,5	1	-	-	1	-	-	-	1	-	-	-
39HQ 5	4	-	-	1	-	-	-	1	-	-	-	-
39HQ 5	6	1	1	1	1	1	1	1	1	1	1	1
39HQ 6	2,5	2	2	2	2	2	2	2	2	2	2	2
39HQ 6	4	-	2	-	-	-	-	2	-	-	-	-
39HQ 6	6	2	-	2	-	-	-	2	-	-	-	-
39HQ 7	4	-	-	4	-	-	-	-	4	-	-	-
39HQ 7	6	1	1	1	1	1	1	1	1	1	1	1
39HQ 7	8	-	2	-	2	-	-	2	-	-	-	-
39HQ 8	4	-	-	-	2	-	-	-	2	-	-	-
39HQ 8	6	-	-	2	-	-	-	-	2	-	-	-
39HQ 8	8	-	-	4	-	-	-	-	4	-	-	-
39HQ 8	10	-	-	9	-	-	-	-	9	-	-	-
39HQ 10	6	2	2	2	2	2	2	2	2	2	2	2
39HQ 10	8	2	2	2	2	2	2	2	2	2	2	2
39HQ 10	10	2	4	1	2	4	1	2	4	1	2	4
39HQ 10	12	-	-	6	-	6	-	6	-	6	-	6
39HQ 11	4	-	1	1	2	2	-	1	1	2	2	2
39HQ 11	6	-	1	2	2	4	-	2	2	4	4	4
39HQ 11	8	-	2	-	4	-	-	-	4	-	-	-
39HQ 11	10	-	1	2	4	-	-	1	2	4	-	-
39HQ 11	12	-	-	3	-	6	-	3	-	6	-	6
39HQ 12	4	-	-	3	3	3	-	-	3	3	3	3
39HQ 12	6	-	-	3	3	6	-	-	3	3	6	6
39HQ 12	8	-	-	6	-	6	-	-	6	-	6	6
39HQ 12	10	-	-	3	-	3	-	-	3	-	3	3
39HQ 12	12	-	-	9	-	9	-	-	9	-	9	9
39HQ 12	14	-	-	3	3	3	3	3	3	3	3	3
39HQ 13	6	-	3	3	1	1	-	3	3	1	1	1
39HQ 13	8	-	6	2	2	2	-	6	6	2	2	2
39HQ 13	10	-	3	6	1	2	-	3	6	1	2	2
39HQ 13	12	-	-	9	-	9	-	-	9	-	9	9
39HQ 13	14	-	3	9	1	3	-	3	9	1	3	3
39HQ 13	16	-	-	12	-	12	-	-	12	-	12	12
39HQ 14	8	-	2	2	2	2	2	2	2	2	2	2
39HQ 14	10	-	4	4	-	4	-	4	4	-	4	4
39HQ 14	12	-	2	4	2	4	2	2	4	2	4	4
39HQ 14	14	-	-	6	-	6	-	-	6	-	6	6
39HQ 14	16	-	2	6	2	6	2	2	6	2	6	6
39HQ 14	18	-	-	8	-	8	-	-	8	-	8	8
39HQ 15	6	-	1	1	3	3	-	1	1	3	3	3
39HQ 15	8	-	-	2	-	6	-	2	-	6	-	6
39HQ 15	10	-	1	2	3	6	-	1	2	3	6	6
39HQ 15	12	-	-	3	-	9	-	-	3	-	9	9
39HQ 15	14	-	1	3	3	3	3	3	3	3	3	3
39HQ 15	16	-	-	4	-	12	-	-	4	-	12	12
39HQ 16	6	-	-	4	-	4	-	-	4	-	4	4
39HQ 16	8	-	-	8	-	8	-	-	8	-	8	8
39HQ 16	10	-	-	4	-	4	-	-	4	-	4	4
39HQ 16	12	-	-	12	-	12	-	-	12	-	12	12
39HQ 16	14	-	-	3	-	3	-	-	3	-	3	3
39HQ 16	16	-	-	6	-	6	-	-	6	-	6	6
39HQ 16	18	-	-	12	-	12	-	-	12	-	12	12
39HQ 16	20	-	-	16	-	16	-	-	16	-	16	16
39HQ 16	22	-	-	20	-	20	-	-	20	-	20	20
39HQ 16	24	-	-	24	-	24	-	-	24	-	24	24
39HQ 16	26	-	-	30	-	30	-	-	30	-	30	30
39HQ 16	28	-	-	36	-	36	-	-	36	-	36	36
39HQ 16	30	-	-	4	-	4	-	-	4	-	4	4
39HQ 16	32	-	-	8	-	8	-	-	8	-	8	8
39HQ 16	34	-	-	12	-	12	-	-	12	-	12	12
39HQ 16	36	-	-	16	-	16	-	-	16	-	16	16
39HQ 16	38	-	-	20	-	20	-	-	20	-	20	20
39HQ 16	40	-	-	24	-	24	-	-	24	-	24	24
39HQ 16	42	-	-	28	-	28	-	-	28	-	28	28
39HQ 16	44	-	-	32	-	32	-	-	32	-	32	32
39HQ 16	46	-	-	36	-	36	-	-	36	-	36	36
39HQ 16	48	-	-	40	-	40	-	-	40	-	40	40
39HQ 16	50	-	-	44	-	44	-	-	44	-	44	44
39HQ 16	52	-	-	48	-	48	-	-	48	-	48	48
39HQ 16	54	-	-	52	-	52	-	-	52	-	52	52
39HQ 16	56	-	-	56	-	56	-	-	56	-	56	56
39HQ 16	58	-	-	60	-	60	-	-	60	-	60	60
39HQ 16	60	-	-	64	-	64	-	-	64	-	64	64

**APPENDIX-4****ALARKO****Carrier**ALARKO CARRIER  
SANAYİ VE TİCARET A.Ş.**İSTANBUL ŞUBE**GOSB-Gebze Organize Sanayi Bölgesi  
Ş. Bilgisu Cad. 41480 Gebze-KOCAELİ  
Tel. / Phone : (262) 648 60 00  
Faks / Fax : (262) 648 60 08  
Tic. Sic. / Registration No. : 85696 / 29776İLGİLİ YAZINIZDA AŞAĞIDAKİ İŞARETİMİZİ BELİRTİNİZ:  
PLEASE ADDRESS CORRESPONDENCE TO:

- TARİH / DATE :
- İŞARETİMİZ / OUR REFERENCE :
- İŞARETİNİZ / YOUR REFERENCE :

ÖZÜ / SUBJECT :

**DECLARATION of CONFORMITY for MACHINERY**

Alarko Carrier Sanayi ve Ticaret A.Ş. hereby declares that the air handling units ;

**39HQ series**

comply with the following directives and standards applying to it :

**Directives :****2006 / 42 / EC****Standards :**

**EN ISO 12100-1**  
**EN ISO 12100-2**  
**TS EN ISO 13850**  
**TS EN ISO 13857**  
**EN 60204-1**

Alarko Carrier Sanayi ve Ticaret A.Ş. points out that the unit is destined to be integrated with other equipments. On the basis that the Machinery Directive applies to the completed system. We therefore confirm that the above mentioned declaration is not applicable to the installation and putting into operation of the unit itself. However it does comply with all relevant European Standards.

The installer is responsible for the CE certification of the complete installation, including the air handling unit.

Gebze, 16 Dec 2009

 **ALARKO**  
  
 ALARKO CARRIER  
 SANAYİ VE TİCARET A.Ş.

**Murat ÇOPUR**  
 Vice President - Factories





**ALARKO**



ALARKO CARRIER  
SANAYİ VE TİCARET A.Ş.

**İSTANBUL** : GOSB - Gebze Org. San. Bölgesi, Ş. Bilgisu Cad. 41480 Gebze-KOCAELİ  
Tel: (0262) 648 60 00 - Fax: (0262) 648 60 08  
**ANKARA** : Sedat Simavi Sok. No: 48, 06550 Çankaya - ANKARA  
Tel: (0312) 409 52 00 - Fax: (0312) 440 79 30  
**İZMİR** : Şehit Fethibey Cad. No:55, Kat:13, 35210 Pasaport - İZMİR  
Tel: (0232) 483 25 60 - Fax: (0232) 441 55 13  
**ADANA** : Ziyapaşa Bulvarı Çelik Ap. No : 25/5-6, 01130 ADANA  
Tel: (0322) 457 62 23 - Fax: (0322) 453 05 84  
**ANTALYA** : Metin Kasapoğlu Cad. Küçukkaya Sitesi A Blok No: 1 D. 4, ANTALYA  
Tel: (0242) 322 00 29 - Fax: (0242) 322 87 66  
**MDH** : 444 0 128

web: [www.alarko-carrier.com.tr](http://www.alarko-carrier.com.tr)  
e-posta: [info@alarko-carrier.com.tr](mailto:info@alarko-carrier.com.tr)