



Installation Instructions

SAFETY CONSIDERATIONS

Installation, start-up and servicing of this equipment can be hazardous due to system pressures, electrical components, and equipment location (roofs, elevated structures, etc.).

Only trained, qualified installers and service mechanics should install, start up, and service this equipment.

Untrained personnel can perform basic maintenance functions of cleaning coils, and cleaning and replacing filters. All other operations should be performed by trained service personnel.

When working on the equipment, observe precautions in the literature; tags, stickers, and labels attached to the equipment; and any other safety precautions that apply.

- Follow all safety codes.
- Wear safety glasses and work gloves.
- Use care in handling, rigging, and setting bulky equipment.

⚠ WARNING

Shut off power to equipment before performing maintenance or service. Electric shock can cause personal injury or death.

INSTALLATION

Step 1 — Check Equipment and Jobsite

UNPACKAGE UNIT

1. Move to final location.
2. Remove shipping material. See Table 1 for unit weight. See Fig. 1 for unit dimensions.

INSPECT EQUIPMENT — File claim with shipping company if shipment is damaged or incomplete.

SYSTEM REQUIREMENTS — Complete or consider these requirements before installation:

1. Consult local building codes and NEC (National Electrical Code) for special installation requirements.
2. Provide sufficient space for piping, condensate drain, wiring, and servicing unit.

Table 1 — Physical Data

UNIT 40BB	007
Nominal Tons	6
Shipping Weight (lbs)	244
Operating Weight (lbs)	235
Filter (no...in.) Throwaway	2...20 x 20 x 2
Blower Motor	
Motor Hp...Rpm	1.0 ... 1750
NEMA Frame Size	56
Adjustable Pulley Pitch (in.)	3.3-4.1
Speed Range (rpm)	730-950
Maximum Speed (rpm)	2000
Blower Pulley Size (in.)	7.66
Coil	
Rows...Fins/in.	3...13
Face Area (sq. in.)	5.00
Liquid Line Connection (TXV Inlet) (in.)	1/2 OD SWT
Suction Line Connection (in.)	1 1/8 OD SWT
Condensate Line Connection (in.)	3/4 FPT

SWT — Sweat Connection
TXV — Thermal Expansion Valve

Step 2 — Suspend Unit — Suspend unit or support it from floor. The 40BB007 units have 3/8-16 weld nuts provided in each corner of the top for suspending the unit with threaded rod. See Fig. 2.

⚠ WARNING

Before installing unit, determine whether unit weight can be safely supported. Possible injury and damage may result due to joist or truss overloading.

Step 3 — Connect Ductwork — Connect the supply and return air duct over the outside of the flange provided. Secure the duct to the flange, using proper fasteners for the type of duct used. Tape the duct-to-unit joint.

Use of flexible connectors between ductwork and unit will prevent transmission of vibration. Ductwork passing through unconditioned space must be insulated and covered with a vapor barrier.

DUCTWORK ACOUSTICAL TREATMENT — Metal duct systems that do not have a 90° elbow and 10 ft of main duct to first branch take off may require internal acoustical insulation lining.

Line the inside of plenum, branch runs, and main duct with acoustical insulation in accordance with the latest edition of the Sheet Metal and Air Conditioning Contractors National Association (SMACNA) application standard for duct liner. Duct liners should be UL (Underwriter's Laboratories) classified batts and blankets with fire hazard classification working of FHC-25/50 or less. Ensure main duct lining is extended 6 to 8 ft down the duct from the plenum.

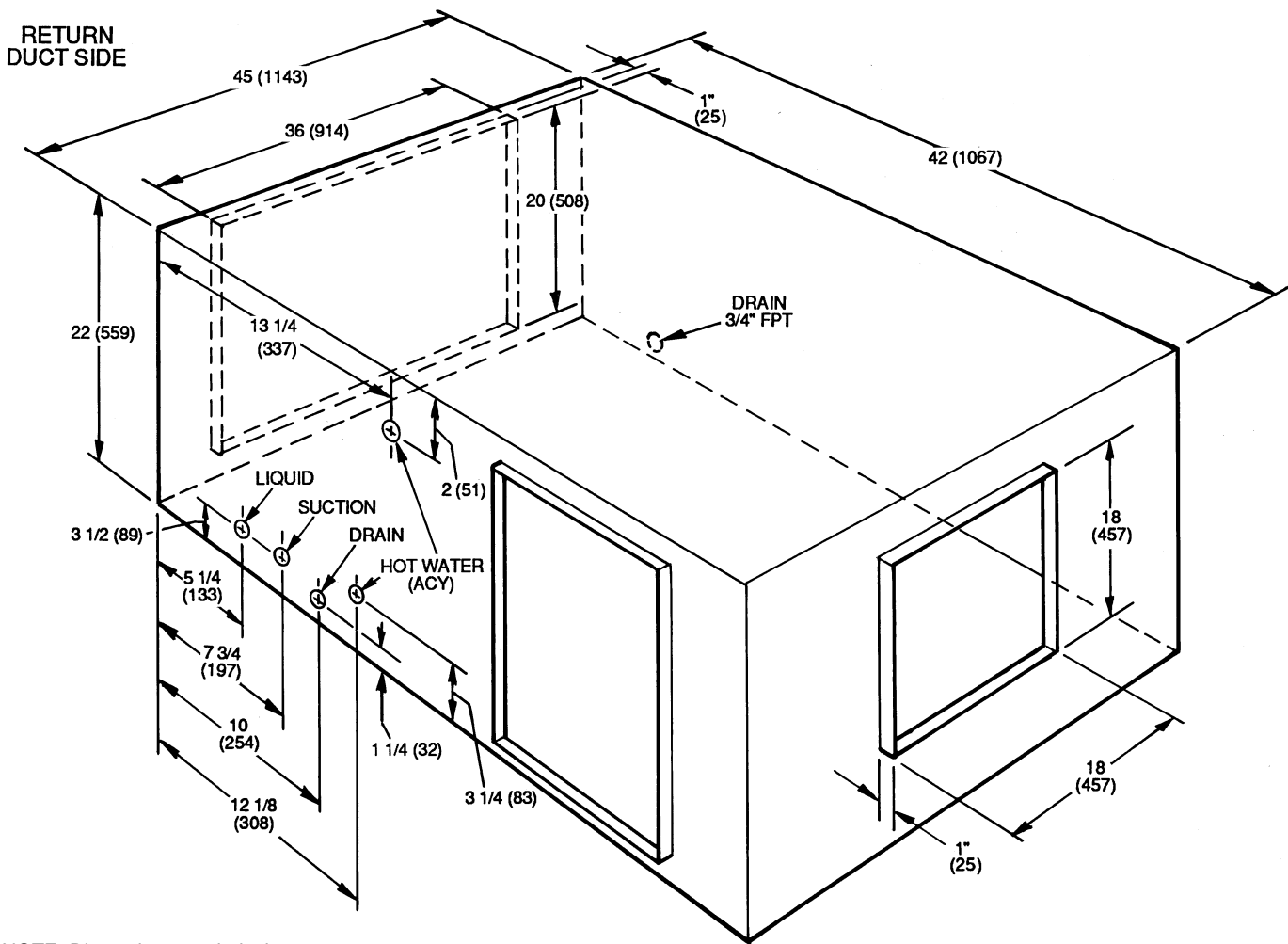

NOTE: Dimensions are in inches.
 () are in millimeters.

Fig. 1 — Base Unit Dimensions

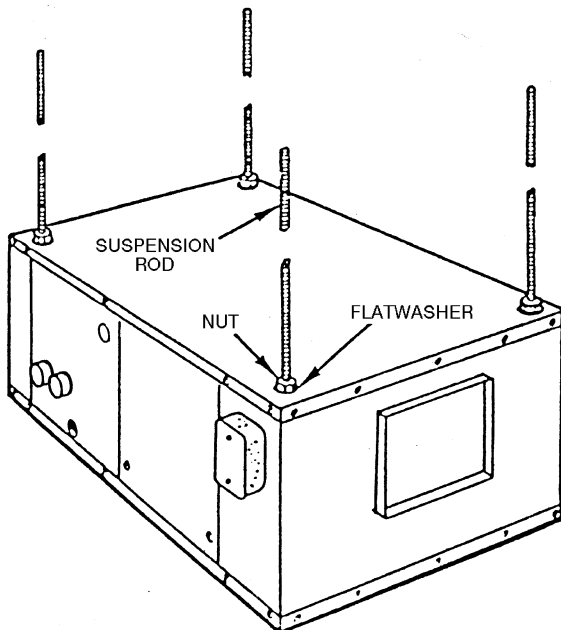

Fig. 2 — Unit Suspended from Ceiling

Fibrous ductwork may also be used if constructed and installed in accordance with the latest addition of SMACNA construction standard on fibrous glass ducts. Both acoustical lining and fibrous ductwork shall comply with NFPA (National Fire Protection Association) as tested in accordance with UL Standard 181 for Class 1 air ducts.

Step 4 — Install Condensate Drain — Condensate drain must consist of a minimum of 7/8-in. OD copper tubing or 3/4-in. galvanized iron pipe or PVC-type plastic pipe. Ensure drain pitches downward at a slope of 1 in. to every 10 ft.

Install a 3- to 4-in. trap in condensate line as close to unit as possible. See Fig. 3. Ensure top of trap is level beneath the connection to unit to prevent condensate from overflowing the drain pan. There are two condensate drain connections provided. Ensure that the unused connection is plugged. Be sure to consult local codes for additional precautions before installing condensate drain.

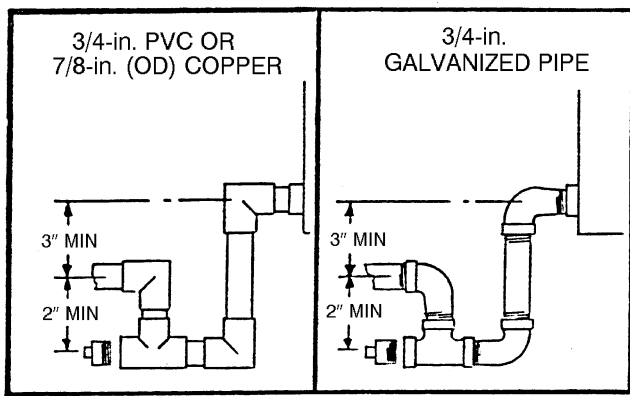

Fig. 3 — Condensate Drain Connections

⚠ CAUTION

If unit is located above an area where damage can result from condensate overflow, install a watertight pan of corrosion-resistant metal beneath unit to catch any overflow due to clogged drains or other reasons. A separate 3/4-in. condensate drain must be provided from this added pan. See Fig. 4.

Step 5 — Install Refrigerant Lines — Connect refrigerant lines to refrigerant line connections. See Fig. 1 and Table 1 for line connection sizes, type, and location. Tubing must be refrigerant grade and must be clean, undamaged, and uncontaminated. Tubing and indoor coil should be evacuated prior to charging system.

Refer to condensing unit Product Data for proper line sizing. The TXV (thermal expansion valve) is factory installed. The TXV sensing bulb must be mounted on the field-installed suction line as shown in Fig. 5.

NOTE: It is recommended that a freeze-stat device be installed if a hot water coil is used and is mounted in the re-heat position.

Step 6 — Motor Alignment and Adjustment — Units will be shipped with motor and drive installed. Ensure all shipping bolts/screws are removed and all other bolts and screws are tight. Check the sheaves for alignment and ensure the setscrews are tight. See Table 2 for fan performance data. See Table 3 for Fan Electrical data.

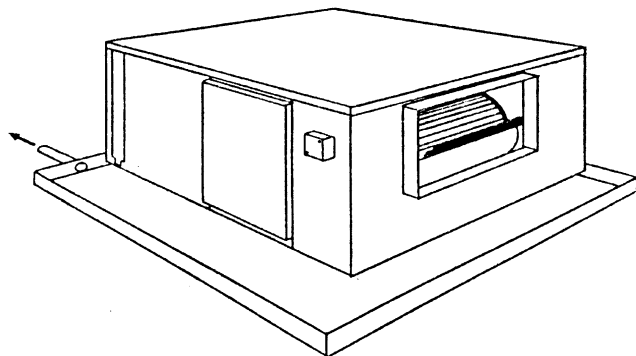

Fig. 4 — Condensate Pan Installation

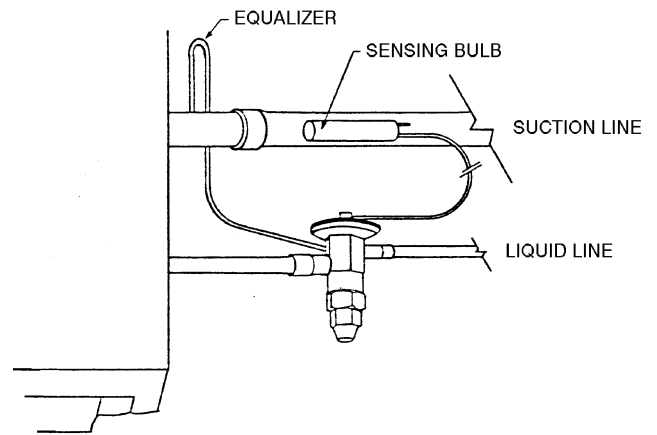

Fig. 5 — TXV Valve Installation

To change fan speed:

1. Shut off unit power supply.
2. Loosen belt by loosening fan motor mounting nuts.
3. Loosen movable pulley flange setscrew (see Fig. 6).
4. Screw movable flange toward fixed flange to increase speed and away from fixed flange to decrease speed. Increasing fan speed increases load on motor. Do not exceed maximum speed specified in Table 1.
5. Set movable flange at nearest keyway of pulley hub and tighten setscrew.

To align fan and motor pulleys:

1. Loosen fan pulley setscrews.
2. Slide fan pulley along fan shaft. See Fig. 6.
3. Make angular alignment by loosening motor from mounting.
4. Tighten setscrews.

To adjust belt tension:

1. Loosen fan motor mounting nuts.
2. Slide motor mounting plate away from fan for proper belt tension (1/2-in. deflection with one finger).
3. Tighten nuts.
4. Secure motor in fixed position.

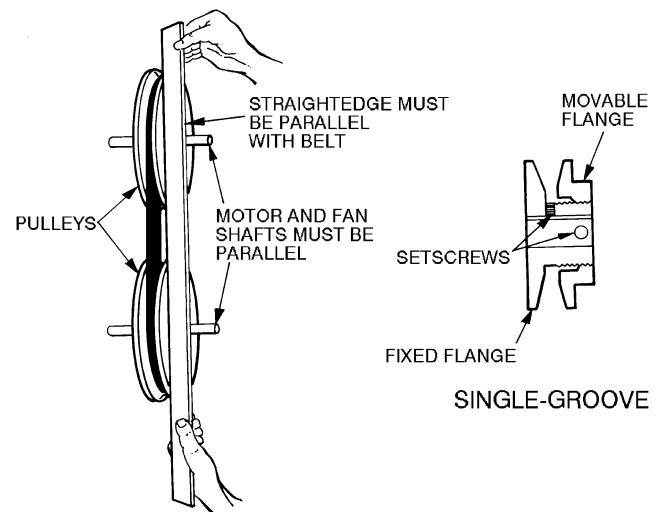

Fig. 6 — Evaporator-Fan Pulley Adjustment

Table 2 — Fan Performance

UNIT 40BB	INTERNAL STATIC PRESSURE	CFM	EXTERNAL STATIC PRESSURE (in. wg)											
			.25		.50		.75		1.00		1.25		1.50	
			Rpm	Bhp	Rpm	Bhp	Rpm	Bhp	Rpm	Bhp	Rpm	Bhp	Rpm	Bhp
007	.23	1750	566	.31	700	.41	808	.50	910	.61	1000	.72	1100	.85
	.29	2000	609	.38	726	.48	831	.59	925	.70	1011	.83	1100	.97
	.36	2250	659	.46	758	.57	863	.71	943	.81	1028	.95	1113	1.11
	.44	2500	700	.60	803	.73	866	.82	971	.94	1050	1.10	1131	1.27

Bhp — Brake horsepower
Rpm — Revolutions per minute

NOTE: Maximum blower speed is 2000 rpm, with a maximum horsepower of 3.0.

Table 3 — Electrical Data

UNIT 40BB007	BLOWER MOTOR
V-Ph-Hz	FLA
115-1-60	13.4
208-1-60	7.4
230-1-60	6.7

Step 7 — Control Wiring — A control box is mounted on each unit and the motor is to be wired to this box. Motor is factory wired for 208/230v operation.

Unit must be permanently grounded in accordance with NEC and local codes and ordinances. See typical wiring diagrams for wiring connections (Fig. 7).

Install accessory fan contactor P/N 40RR900181. Wire 24-v contactor control coil as shown in the condensing unit wiring diagram.

Check for proper rotation of the blower pulley. The rotation of single-phase motors can be reversed by exchanging leads inside the motor junction box. Refer to motor nameplate. Ensure all filters are installed. Check the amperage draw of the motor, with all doors, panels, etc. in place. This should not exceed the nameplate amps shown on the motor serial plate. Never assume the voltage and phase on the unit nameplate is the same as the motor is wired.

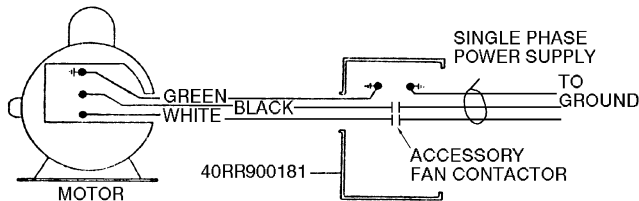

NOTE: Disconnect power supply before servicing equipment.

Fig. 7 — Power Supply Wiring Connections

Step 8 — Accessory Installation

HOT WATER COIL (In Reheat Position)
 (P/N KFCHW6001HWC)

1. Remove access panel from both sides of cabinet.
2. Remove knockouts from hot water coil stubouts. Coils stub out the cabinet for left-hand connections (facing air-flow).
3. Remove 2 galvanized strips from hot water coil package. Install angle strip with notches resting in drain pan, and 1/2 in. flange pointing toward blower. Secure this angle strip to end plate of cooling coil by clips supplied in package. See Fig. 8. Place clips at each end of strip as close as possible to flange.

4. Install other angle strip at top of cooling coil, with 1/2-in. flange resting on top of cooling coil, pointing to rear. Place clip as high as possible on this strip. Secure it to end plate of cooling coil. Metal strips prevent air from bypassing heating coil and serve as support for coil.
5. After strips are secured, install hot water coil inside cabinet through the access door on the opposite side where connections stub out. Raise coil slightly above drain pan and line up stubouts with knockout holes in cabinet. When stubouts are extended through holes, hot water coil should rest on flange of bottom angle strip with hot water coil and cooling coil end plates lined up evenly.
6. Secure hot water to cooling coil by fastening 2 clips over cooling coil and hot water coil end plates, (see Fig. 9).

NOTE: When used in reheat position with cooling coil, install a freeze-stat on cooling coil to prevent freeze-up.

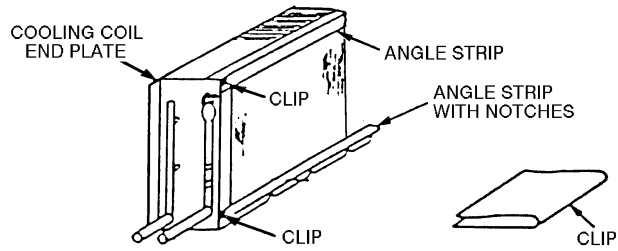

Fig. 8 — Installing Angle Strips

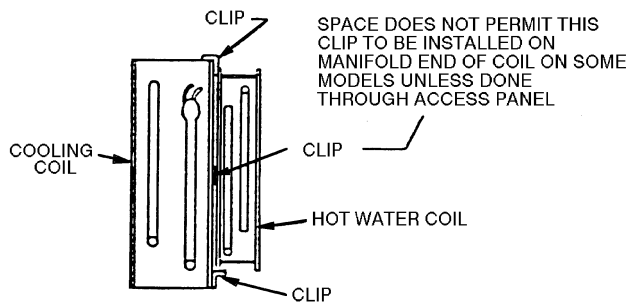

Fig. 9 — Securing Hot Water Coil

HOT WATER COIL (in Preheat Position)

(P/N KFCHW6001HWC) — To install the hot water coil in preheat position, the cooling coil must be removed. See Fig. 10 for hot water coil positioning. Perform the following procedure:

1. Remove access panels from both sides of cabinet.
2. Remove cooling coil from unit.
3. Follow directions for installing the unit in reheat position, but place hot water coil in preheat position. See Fig. 10. Connections and knockouts must be field-supplied.
4. Reinstall cooling coil in unit.
5. Replace access panels.

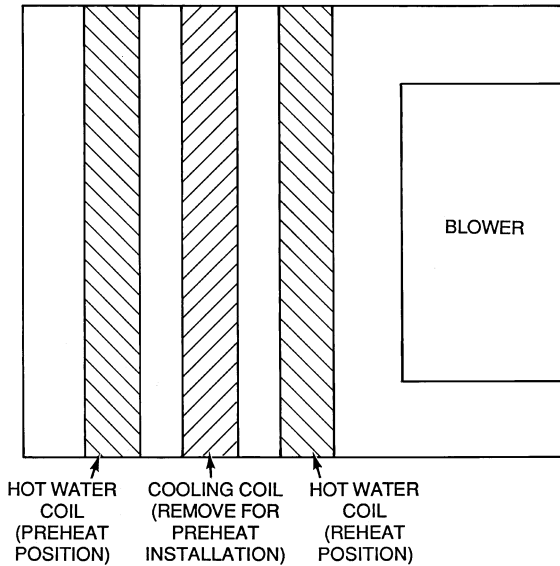

Fig. 10 — Hot Water Coil Installation

MAINTENANCE

⚠ WARNING

Disconnect electrical power to all circuits before servicing unit. Failure to do so may result in personal injury from electrical shock or moving parts.

Return Air Filters — Filter access is from either side of unit. Inspect on a regular basis (at least monthly) and clean or replace as needed.

⚠ CAUTION

Never operate unit without a filter or with filter access door removed. Damage to blower motor may result.

Coil Cleaning — Coil is easily cleaned when dry. To check or clean, remove unit access panel, filter access door and filters. Uses accepted industry methods for cleaning. Remove all foreign matter from pan and condensate drain line. Check for rust and holes.

Belt and Pulley — Proper pulley alignment and belt tension must be maintained at all times. Speed is reduced by adjusting pulley faces so they are farther apart; speed is increased with faces closer together. Check pulley setscrews and bolts. Refer to Motor Alignment and Adjustment section on page 3 for belt and pulley adjustment instructions.

Motor — Use electric motor oil or SAE20 nondetergent oil. Tighten motor bracket and base bolts as required. **DO NOT OVER-OIL.**

Blower — Check bearing for wear. Replace as required. Check wheel for accumulation of dirt and clean as required.

