

40MKCBB/ 24AHA4**
40MKCBB/124ANS**
40MKQBB/25HHA4**
40MKQBB/224ANS**
High-Wall Ductless Split System
Sizes 18 to 36

Installation Instructions



Fig. 1 - Remote Control and Indoor and Outdoor Units

NOTE: Read the entire instruction manual before starting the installation.

TABLE OF CONTENTS	
SAFETY CONSIDERATIONS	1
PARTS LIST	2
DIMENSIONS - INDOOR	4
DIMENSIONS - OUTDOOR	5
CLEARANCES - INDOOR	7
CLEARANCES - OUTDOOR	7
SYSTEM REQUIREMENTS	7
INSTALLATION	9
INSTALL INDOOR UNIT	9
INSTALL OUTDOOR UNIT	10
ELECTRICAL DATA	14
START-UP	18
TROUBLESHOOTING	20

⚠ WARNING

UNIT OPERATION AND SAFETY HAZARD

Failure to follow this warning could result in personal injury or equipment damage.

Puron refrigerant systems operate at higher pressures than standard R-22 systems. To avoid damage to the unit or possible personal injury, do not use R-22 service equipment or components on Puron refrigerant equipment.

SAFETY CONSIDERATIONS

Improper installation, adjustment, alteration, service, maintenance, or use can cause explosion, fire, electrical shock, or other conditions which may cause death, personal injury, or property damage. Consult a qualified installer, service agency, or your distributor or branch for information or assistance. The qualified installer or agency must use factory-authorized kits or accessories when modifying this product. Refer to the individual instructions packaged with the kits or accessories when installing.

Follow all safety codes. Wear safety glasses, protective clothing, and work gloves. Use quenching cloth for brazing operations. Have fire extinguisher available. Read these instructions thoroughly and follow all warnings or cautions included in literature and attached to the unit. Consult local building codes and current editions of the National Electrical Code (NEC) NFPA 70. In Canada, refer to current editions of the Canadian electrical code CSA 22.1.

Recognize safety information. This is the safety-alert symbol **⚠**. When you see this symbol on the unit and in instructions or manuals, be alert to the potential for personal injury. Understand these signal words; **DANGER**, **WARNING**, and **CAUTION**. These words are used with the safety-alert symbol. **DANGER** identifies the most serious hazards which **will** result in severe personal injury or death. **WARNING** signifies hazards which **could** result in personal injury or death. **CAUTION** is used to identify unsafe practices which **may** result in minor personal injury or product and property damage.

NOTE is used to highlight suggestions which will result in enhanced installation, reliability, or operation.

⚠ WARNING

ELECTRICAL SHOCK HAZARD

Failure to follow this warning could result in personal injury or death.

Before installing, modifying, or servicing system, main electrical disconnect switch must be in the OFF position. There may be more than 1 disconnect switch. Lock out and tag switch with a suitable warning label.

⚠ CAUTION

ENVIRONMENTAL HAZARD

Failure to follow this caution may result in environmental pollution.

Remove and recycle all components or materials (i.e. oil, refrigerant, etc.) before unit final disposal.

INSTALLATION

IMPORTANT: Effective January 1, 2015, all split systems and packaged air conditioners must be installed pursuant to applicable regional efficiency standards issues by the Department of Energy.

⚠ CAUTION

CUT HAZARD

Failure to follow this caution may result in personal injury.

Sheet metal parts have sharp edges or burrs, Use care and wear appropriate protective clothing and gloves when handling parts.

⚠ CAUTION

PERSONAL INJURY AND EQUIPMENT DAMAGE HAZARD

Failure to follow this caution may result in personal injury and / or equipment damage.

DO NOT operate the unit without a filter or with grille removed.

These instructions cover the installation and the start-up of the systems listed in Table 1.

Table 1 – Matched Systems

System Type	Nominal Capacity	Outdoor Unit		Indoor Unit
Cooling Only	018	24AHA418A003	124ANS018000	40MKCB18B--3
	022	24AHA424A003	124ANS024000	40MKCB22B--3
	028	24AHA430A003	124ANS030000	40MKCB28B--3
	032	24AHA436A003/5/6	124ANS036000	40MKCB32B--3
Heat Pump	024	25HHA424A003	224ANS02400	40MKQB24B--3
	028	25HHA430A003	224ANS030000	40MKQB28B--3

PARTS LIST

Control Voltage Adapter Kit for High Wall Units

⚠ WARNING

ELECTRICAL OPERATION HAZARD

Failure to follow this warning could result in personal injury or death.

Indoor unit uses 230V control signal.
Outdoor unit uses 24V control signal.
Control Voltage Adapter Kit required.

The high wall unit (40MKC(Q)**B) and horizontal discharge unit (24AHA/124ANS and 25HHA4/224ANS) would not be compatible without the addition of the control voltage adapter kit. If you do not have this kit, do not attempt to install the units. Order the kit, and install the outdoor and indoor units when this is available.

Cooling Only Kit (KAAVC0101AAA):

The kit is designed to allow communication between specific combinations of cooling only indoor and outdoor units stated in this document. The kit is compatible with 208/230V high wall (40MKCB**B) ductless indoor units paired with 208/230/460V horizontal discharge outdoor (24AHA4/124ANS) units with single-phase or three-phase power at 60Hz.

The KAAVC0101AAA kit converts high-voltage control signals from a high wall indoor unit into low-voltage control signals for a horizontal outdoor unit. In cooling only systems, the kit carries the compressor control signal.

The kit consists of one transformer and four wires which are designed to mount within the outdoor unit. The kit is pre-wired for cooling-only applications; there are four free wires available for the installer to connect to the indoor and outdoor units.

Parts necessary for mounting and connecting the Kit are included in the kit.

Heat Pump Kit (KHAVC0101AAA)

The kit is designed to allow communication between specific combinations of heat pump indoor and outdoor units stated in this document. The kit is compatible with 208/230V high wall (40MKQB**B) ductless indoor units and 208/230V horizontal discharge (25HHA4/224ANS) outdoor units with single-phase or three-phase power at 60Hz. The kit is not compatible with 460V outdoor units.

The KHAVC0101AAA Kit converts high-voltage control signals from a high wall indoor unit into low-voltage control signals for a horizontal outdoor unit. In heat pump systems, the kit carries both the compressor and the reversing valve control signals. The kit consists of two relays and one transformer mounted to a metal bracket which is designed to fit within the outdoor unit. The kit is pre-wired for heat pump applications; there are nine free wires available for the installer to connect to the indoor and outdoor units. Parts necessary for mounting and connecting the KHAVC0101AAA kit are included in the kit.

Refer to the kit's installation instructions for installation of the kit.

Indoor Unit

The following items are included with the indoor unit:

Table 2 – Indoor Units Parts List

Name of Part	Qty.	Usage
Wall Mounting Bracket	1	For Indoor Unit Installation
Screws, GBT845/ST3.9 x 25-C-H(S)	8/15*	For Attaching The Mounting Bracket To The Wall
Screw anchor	8/15*	Enable attachment of mounting screws as needed in certain wall type
Remote Control	1	For Controlling Unit
Remote Control Holder	1	Holder For Remote Control
Screws, GBT846/ST2.9 x 10-C-H(S)	2	For Attaching The Remote Control Holder To The Wall
Battery	2	To power remote control
Installation instructions	1	Guide to install the system
Owner's manuals	1	Guide to the owner

*8 screws for AC unit sizes 18K and 22K. 15 screws for AC unit sizes 28K and 32K and heat pump sizes 24K and 28K.

Outdoor Unit

The following items are included with the outdoor unit:

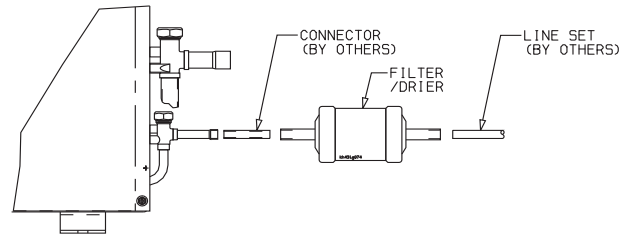

A09536

Fig. 2 - 24AHA/124ANS

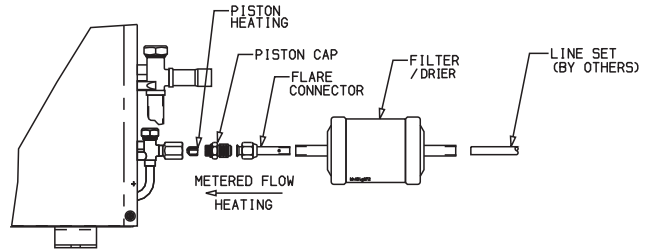

A09537

Fig. 3 - 25HHA4/224ANS

Table 3 – Outdoor Unit Parts Checklist

Model	Filter Drier	Piston Cap	Pistons	Flare Connector
24AHA4/124ANS	✓			
25HHA4/224ANS	✓	✓	✓	✓

DIMENSIONS - INDOOR

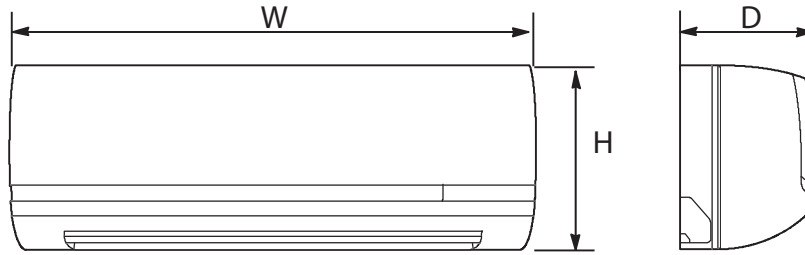

Fig. 4 - 40MKC**B, 40MKQ**B Unit Dimensions

A08447

Table 4 – Dimensions Indoor

High wall Indoor Unit size (BTU/Hr)	Height (H) in. (mm)	Width (W) in. (mm)	Depth (D) in. (mm)	Operating Weight lb (kg)
AC				
18K and 22K	13.39 (343)	46.69 (1186)	10.16 (258)	17 (7.71)
28K and 32K	13.38 (340)	57.09 (1450)	10.43 (265)	25 (11.34)
HP				
24K and 28K	13.38 (340)	57.09 (1450)	10.43 (265)	25 (11.34)

DIMENSIONS - OUTDOOR

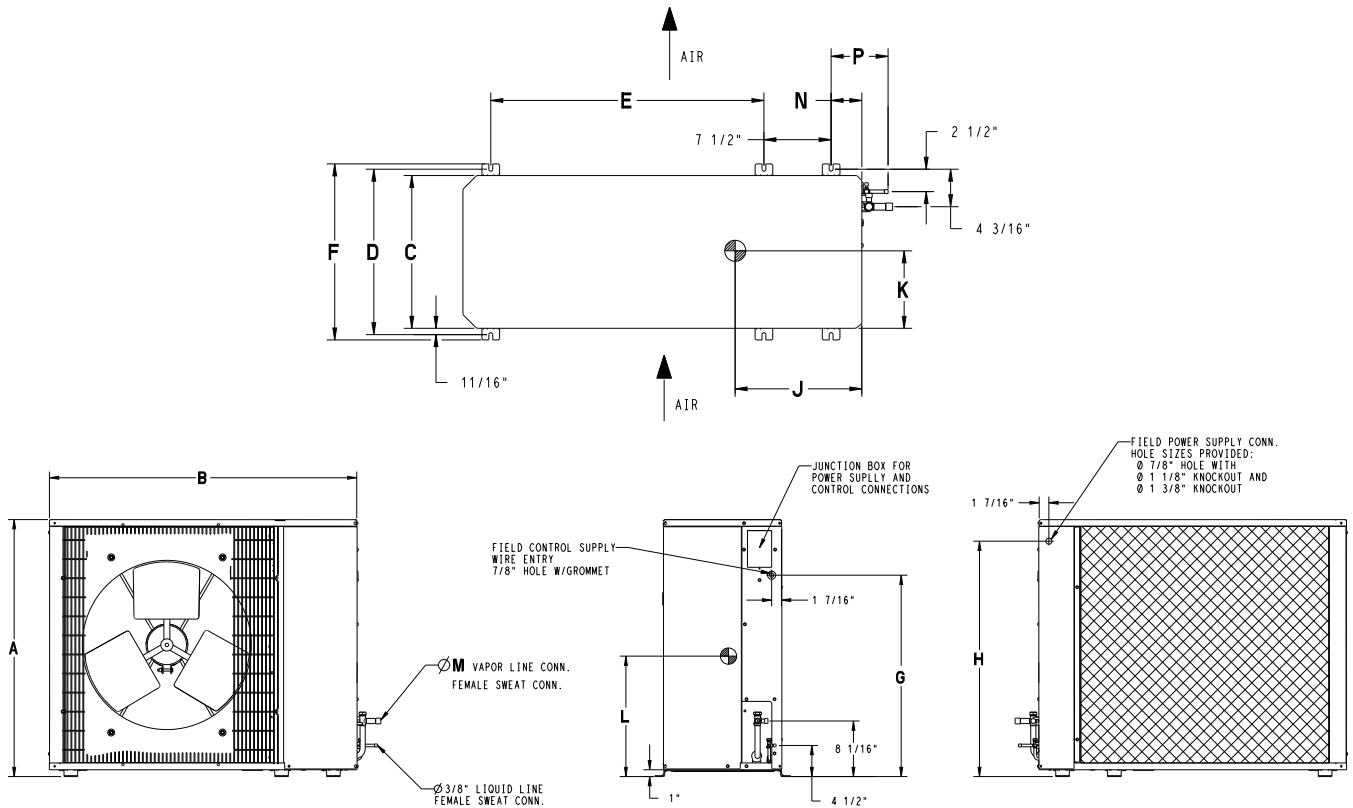



Fig. 5 - Outdoor Unit Dimensions

NOTE:

- Center of Gravity 
- All dimensions are in "inches" unless noted.

UNIT SIZE	MINIMUM MOUNTING PAD DIMENSIONS
18,24	23" x 42"
30,36	24" x 50"

Table 6 – Dimensions (ACs)

UNIT	SERIES	ELECTRICAL CHARACTERISTICS	A	B	C	D	E	F	G	H	J	K	L	M	N	P	OPERATING WEIGHT(lbs)	SHIPPING WEIGHT(lbs)	SHIPPING DIMENSIONS (L x W x H)			
124ANS018000/ 24AHA418	0	X	0	0	0	31 1/8"	36 15/16"	14 9/16"	16"	23 7/16"	17 3/16"	23 1/8"	28 1/16"	13"	6 5/8"	11 1/4"	5/8"	2 7/8"	5 13/16"	146	166	42 15/16" X 18" X 34 1/8"
124ANS024000/ 24AHA424	0	X	0	0	0	31 1/8"	36 15/16"	14 9/16"	16"	23 7/16"	17 3/16"	23 1/8"	28 1/16"	14"	6 3/4"	11 5/8"	3/4"	2 7/8"	5 13/16"	148	168	42 15/16" X 18" X 34 1/8"
124ANS030000/ 24AHA430	0	X	0	0	0	37 1/8"	44 1/2"	17 1/16"	18 7/16"	30 1/2"	19 5/8"	29 1/8"	34 1/16"	13 11/16"	8 1/8"	15 7/8"	3/4"	3 3/8"	6 3/8"	183	213	50 1/2" X 20 1/2" X 40 1/8"
124ANS036000/ 24AHA436	0	X	0	X	X	37 1/8"	44 1/2"	17 1/16"	18 7/16"	30 1/2"	19 5/8"	29 1/8"	34 1/16"	13 11/16"	8 1/8"	15 7/8"	7/8"	3 3/8"	6 3/8"	184	214	50 1/2" X 20 1/2" X 40 1/8"
	208-230-160	230-160	208/230-3-60	460-3-60																		

Table 7 – Dimensions SI (ACs)

UNIT	SERIES	ELECTRICAL CHARACTERISTICS	A	B	C	D	E	F	G	H	J	K	L	M	N	P	OPERATING WEIGHT(KG)	SHIPPING WEIGHT(KG)	SHIPPING DIMENSIONS (L x W x H)				
124ANS018000/ 24AHA418	0	X	0	0	0	790.4	938.0	370.0	406.0	595.5	436.0	587.6	712.2	330.2	168.3	285.8	15.9	73.0	148.2	75.3	1090.2	1282.7	1090.2 X 457.7 X 866.7
124ANS024000/ 24AHA424	0	X	0	0	0	790.4	938.0	370.0	406.0	595.5	436.0	587.6	712.2	355.6	171.5	295.3	19.1	73.0	148.2	76.2	1090.2	1282.7	1090.2 X 457.7 X 866.7
124ANS030000/ 24AHA430	0	X	0	0	0	942.8	1130.0	433.0	469.0	774.5	499.0	740.0	864.6	347.7	206.4	403.2	19.1	86.0	161.2	96.6	1282.7	1510.9	1282.7 X 520.7 X 1019.1
124ANS036000/ 24AHA436	0	X	0	X	X	942.8	1130.0	433.0	469.0	774.5	499.0	740.0	864.6	347.7	206.4	403.2	22.2	86.0	161.2	97.1	1282.7	1510.9	1282.7 X 520.7 X 1019.1
	208-230-160	230-160	208/230-3-60	460-3-60																			

Table 8 – Dimensions (HPs)

UNIT	SERIES	ELECTRICAL CHARACTERISTICS	A	B	C	D	E	F	G	H	J	K	L	M	N	P	OPERATING WEIGHT(lbs)	SHIPPING WEIGHT(lbs)	SHIPPING DIMENSIONS (L x W x H)			
224ANS024000/ 25HHA424	0	X	0	0	0	31 1/8"	36 15/16"	14 9/16"	16"	23 7/16"	17 3/16"	23 1/8"	28 1/16"	14"	6 3/4"	11 5/8"	3/4"	2 7/8"	4 15/16"	161	181	42 15/16" X 18" X 34 1/8"
224ANS030000/ 25HHA430	0	X	0	0	0	37 1/8"	44 1/2"	17 1/16"	18 7/16"	30 1/2"	19 5/8"	29 1/8"	34 1/16"	13 11/16"	8 1/8"	15 7/8"	3/4"	3 3/8"	5 1/2"	196	226	50 1/2" X 20 1/2" X 40 1/8"
	208-230-160	230-160	208/230-3-60	460-3-60																		

Table 9 – Dimensions SI (HPs)

UNIT	SERIES	ELECTRICAL CHARACTERISTICS	A	B	C	D	E	F	G	H	J	K	L	M	N	P	OPERATING WEIGHT(KG)	SHIPPING WEIGHT(KG)	SHIPPING DIMENSIONS (L x W x H)			
224ANS024000/ 25HHA424	0	X	0	0	0	790.4	938.0	370.0	406.0	595.5	436.0	587.6	712.2	355.6	171.5	295.3	19.1	73.0	126.2	161	181	1090.2 X 457.7 X 866.7
224ANS030000/ 25HHA430	0	X	0	0	0	942.8	1130.0	433.0	469.0	774.5	499.0	740.0	864.6	347.7	206.4	403.2	19.1	86.0	139.2	196	226	1282.7 X 520.7 X 1019.1
	208-230-160	230-160	208/230-3-60	460-3-60																		

CLEARANCES - INDOOR

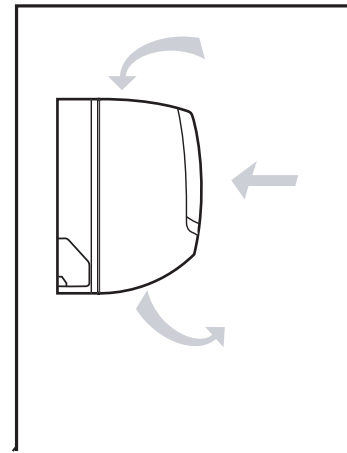
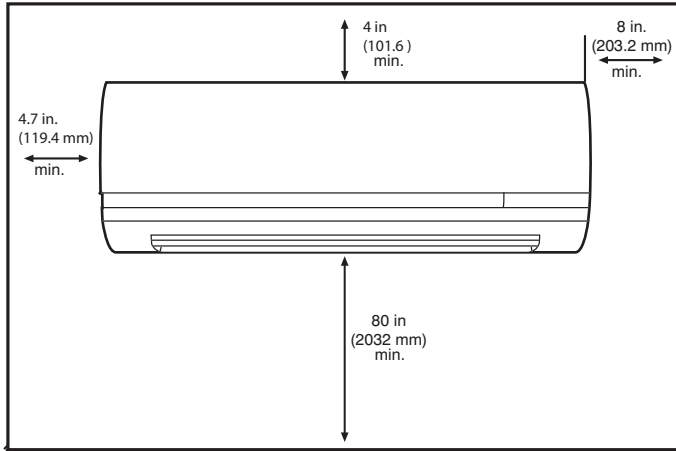

Fig. 6 – 40MKC**B, 40MKQ**B Unit Clearance

A150152

CLEARANCES - OUTDOOR

- Single Unit Applications:** With coil facing wall: Allow 6” (152.4mm) minimum clearance on coil side and coil end and 20” (504.0 mm) minimum clearance on fan side. Allow 24” (609.6 mm) minimum clearance on compressor end for service.
- With fan facing wall:** Allow 8” (203.2 mm) minimum clearance on fan side and coil end and 20” (504.0 mm) minimum clearance on coil side. Allow 24” (609.6 mm) minimum clearance on compressor end for service when units are stacked or there is less than 40” (1016 mm) of clearance above the unit. If there is 40” (1016 mm) clearance above unit and the top panel is accessible for removal allow 8” (203.2 mm) minimum clearance on compressor end for service.
- Multi-unit Applications:** Allow 24” (609.6 mm) minimum clearance between fan and coil sides of multiple units. Arrange units so discharge of one does not enter inlet of another. Allow 24” (609.6 mm) minimum clearance on compressor end when units are stacked or there is less than 40” (1016 mm) of clearance above the unit. If there is 40” (1016 mm) clearance above unit and the top panel is accessible for removal allow 8” (203.2 mm) minimum clearance on compressor end for service. When two units are installed end to end with the coil ends facing each other allow 12” (304.8 mm) minimum clearance between units.

IMPORTANT: When installing multiple units, ensure the discharge air from one unit is not drawn into another unit. When installing single or multiple units in an alcove, roof well, or partially enclosed area, ensure there is adequate ventilation to prevent recirculation of discharge air.

SYSTEM REQUIREMENTS

Clearances

Allow sufficient space around the indoor and outdoor unit for proper airflow circulation and servicing. Refer to Fig.6 and the outdoor unit clearance section for minimum required clearances.

Piping: Piping and insulation is field supplied.

Piping Lengths

The minimum length between the indoor and outdoor units is 10 ft (3 m). Refer to table 9 for the maximum lengths allowed.

Table 9 – Maximum Refrigerant Line Lengths

Unit Size	Max Equivalent Length* ft(m)	Max Elevation (ID over OD) ft(m)	Max Elevation (OD over ID) ft(m)
18K	250 (76.2)	65 (19.8)	200 (61)
24K	250 (76.2)	65 (19.8)	200 (61)
30K	250 (76.2)	65 (19.8)	200 (61)
36K	250 (76.2)	65 (19.8)	200 (61)

Note: For lengths greater than 25 ft (7.6 m), refer to the *Residential Long Line Guide*.

* Maximum actual length not to exceed 200 ft (61 m)
Total equivalent length accounts for losses due to elbows or fitting.
See the Long Line Guideline for details.

Pipe Sizes

Refer to table 10 for pipe sizes.

Table 10 – Pipe Sizes

Unit Size	Pipe Sizes (in)	
	Mix Phase – in	Vapor – in
18K	3/8	5/8
24K	3/8	3/4
30K	3/8	3/4
36K	3/8	7/8

Note: Both lines need to be insulated using at least 1/2 inch closed foam insulation.

Condensate Drain Pipe Sizes

Refer to table 11 for the required sizes.

Table 11 – Drain Pipe Sizes

Unit Size	Outside Diameter – in(mm)	Inside Diameter – in(mm)
18K	11/16 (17.5)	5/8 (16.5)
24K	11/16 (17.5)	5/8 (16.5)
30K	11/16 (17.5)	5/8 (16.5)
36K	11/16 (17.5)	5/8 (16.5)

Refrigerant Charge

The outdoor units can be matched with multiple outdoor units and thus a different amount of charge might be required when matched with the 40MKC**B or 40MKQ**B units. Charge to Sub-cooling Delta from Rating Plate Value as stated below.

Table 12 – Charge Requirements

System Type	Nominal Capacity	Outdoor Unit		Indoor Unit	Charge to Sub-cooling Delta from Rating Plate Value
Cooling Only	018	24AHA418A003	124ANS018000	40MKCB18B--3	12
	022	24AHA424A003	124ANS024000	40MKCB22B--3	12
	028	24AHA430A003	124ANS030000	40MKCB28B--3	12
	032	24AHA436A003/5/6	124ANS036000	40MKCB32B--3	8
Heat Pump	024	25HHA424A003	224ANS024000	40MKQB24B--3	14
	028	25HHA430A003	224ANS030000	40MKQB28B--3	11

NOTE: : The above additional charge is required amount for line lengths up to 25 ft (7.6 m). For line lengths exceeding 25 ft (7.6 m), additional charge will be required. Refer to the *Residential Long Line Guide*.

Metering Device

The metering device(s) for these systems is a type B accurater. The cooling accurater is installed with the indoor unit, while the heating accurater is installed with the outdoor unit. One Accurater is required for the cooling only system and two are required for the heat pump systems. Refer to Table 13 for the accurater size.

Table 13 – Accurater Sizes

System Size	Cooling Only	Heat Pumps	
	40MKC**B	40MKQ**B	25HHA4/224ANS
018	0.046"	-	-
022, 024	0.052"	0.052"	0.049"
028	0.059"	0.057"	0.055"
032	0.065"	-	-

POWER AND CONNECTING CABLES - FIELD SUPPLIED

Recommended Connection Method for Power and Communication Wiring (To minimize communication wiring interference)

Power Wiring:

The main power is supplied to both, the indoor and the outdoor units. The field supplied connecting cable consists of three (3) wires. Two wires are high voltage AC power and one is a ground wire.

Consult your local building codes and the NEC (National Electrical Code) or CEC (Canadian Electrical Code) for special requirements.

All wires must be sized per NEC or CEC and local codes. Use Electrical Data table MCA (minimum circuit amps) and MOCP (maximum over current protection) to correctly size the wires and the disconnect fuse or breakers respectively.

Per caution note, only copper conductors with a minimum 300 volt rating and 2/64--inch thick insulation must be used.

Communication Wiring:

A separate shielded Stranded copper conductor only, with a 600 volt rating and double insulated copper wire, must be used as the communication wire from the outdoor unit to the indoor unit. To minimize voltage drop of the communication wire, use the wire size and maximum lengths shown in Table 14.

Table 14 – Maximum Lengths

Wire Size	Length ft. (m)
18AWG	50 ft. (15 m)
16AWG	50 ft. (15 m) to 100 ft. (30 m)
13AWG	100 ft. (30 m) to 200 ft. (60 m)

⚠ CAUTION

EQUIPMENT DAMAGE HAZARD

Failure to follow the following caution may result in equipment damage or improper operation.

Wires should be sized based on NEC and local codes.

Use copper conductors only with a 600 volt rating and double insulated copper wire.

⚠ WARNING

ELECTRICAL SHOCK HAZARD

Failure to follow this warning could result in personal injury or death. The kit requires high voltage (230V) non-metallic field wire to connect the indoor unit to the kit in the outdoor unit. Some regions may require metal conduit for this wire. Check relevant local building codes before installing. **DO NOT USE** regular low voltage (24V) thermostat wire for communication wiring.

USER INTERFACE

The indoor unit is supplied with a wireless remote control to operate the unit (an Owner's Manual is supplied with the unit). The following accessories are available.

- Wall mounted control.

OPERATING RANGE

Ensure that the system operates within the application guidelines shown in the following tables.

Table 15 – Cooling Operating Range

	Maximum		Minimum	
	DB °F (°C)	WB °F (°C)	DB °F (°C)	WB °F (°C)
Outdoor Unit	125 (51.7)	--	55 (12.8)	--
Indoor Unit	90 (32.2)	84 (29)	64 (18)	59 (29)

Table 16 – Heating Operating Range

	Maximum		Minimum	
	DB °F (°C)	WB °F (°C)	DB °F (°C)	WB °F (°C)
Outdoor Unit	75 (23.9)	67 (19.4)	17 (-8.3)	--
Indoor Unit	80 (27)	--	32 (0)	--

ACCESSORIES

An extensive list of field installed accessories is available for both indoor and outdoor units. Identify what accessories, if any, are required for the application at hand and consult the separate installation instructions for the accessories. Some of the accessories, especially on the indoor units, can be installed much easier if planned ahead.

INSTALLATION

COMPLETE PRE-INSTALLATION CHECKS

- Unpack Unit** - Store the indoor and outdoor units in the original packaging until it is moved to the final site for installation. When unpacking indoor unit, be careful not to lift unit by condensate drain discharge pipe or by refrigerant connections.
- Inspect Shipment** - Upon receipt of shipment, check the indoor and outdoor units for damage. If there is any damage, forward claim papers directly to the transportation company. Manufacturer is not responsible for damage incurred in transit.
- Inspect Parts Supplied With Units** - Check all items against parts list (see the PARTS LIST section). If any items are missing, notify your distributor or manufacturer office. To prevent loss or damage, leave all parts in original packages until installation.

CONSIDER SYSTEM REQUIREMENTS

- Consult local building codes and NEC for special installation requirements.
- When deciding the location of the indoor and outdoor units, ensure that the piping run does not exceed the allowed distances listed in Table 9.
- Make sure the indoor and outdoor units are easily accessible to electrical power.
- Allow sufficient clearances for airflow, wiring, refrigerant piping, and servicing the unit (see the "CLEARANCES - INDOOR" and "CLEARANCES - OUTDOOR" sections).
- Condensate piping can be directed through the inside wall to an approved drain or straight outside.

INSTALL INDOOR UNIT

Plan the installation carefully before you begin.

- Select indoor unit location.
 - A location where there are no obstacles near inlet and outlet area.
 - A location that can bear the weight of the unit.
 - Do not install indoor units near a direct source of heat such as direct sunlight or a heating appliance.
 - Do not install units too close to humid conditions.
- Install Mounting Plate.
 - The factory supplied mounting plate will look like one of the following depending on the size of the unit.

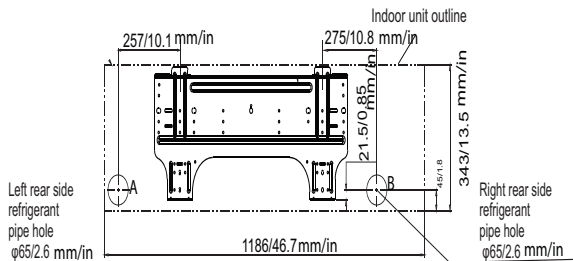

Fig. 7 – 40MKCB18B and 40MKCB22B Mounting plate

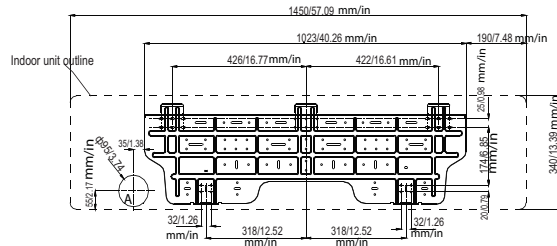
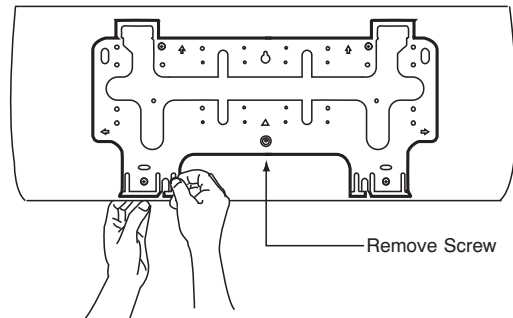

Fig. 8 – 40MKCB28B, 40MKCB32B, 40MKQB24B, and 40MKQB28B Mounting plate

Before mounting the 40MKC(Q)**B unit on the wall mounting bracket, consider how the refrigerant piping will be routed. Complete the following when installing the wall mounting bracket:

- Carefully remove the mounting plate which is attached to the back of the unit by removing any screws and pushing at the indicated pressure points at the bottom of the unit.



A09048

Fig. 9 – Mounting Plate Screw Location

- The mounting plate should be located horizontally and level on the wall. All minimum spacing shown in the "CLEARANCES - INDOOR" section (guided by figures 7 or 8) should be maintained.

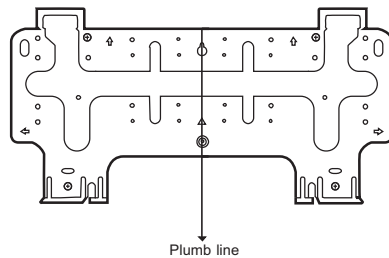

A150163

Fig. 10 – Level Mounting Plate

- Install the wall mounting bracket in a location that is strong enough to withstand the weight of the unit.
 - If the wall is block, brick, concrete or similar material, drill 0.2 in (5 mm) diameter holes and insert anchors for the appropriate mounting screws.
 - Fasten the wall hanging bracket to the wall with 4 or more screw anchors through the holes near the outer edge of the bracket.
 - Install the wall hanging bracket flush to the wall, and ensure the bracket does not move.
- Drill hole in wall for interconnecting piping, drain, and wiring.

Refrigerant Line Routing

Piping for the indoor units can be routed as shown in Fig. 11.

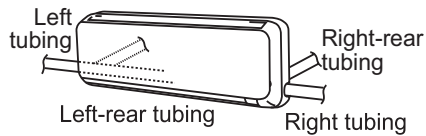

Fig. 11 – Refrigerant Line Routing

NOTE: Only two routing options for specific models (see A in Fig. 8 for the routing option).

Rear Piping

Determine the pipe hole position using the mounting plate as a template. Drill a 2.6 inch (65 mm) or 3.7 inch (95 mm) diameter hole in the wall at point A or B as shown in Fig. 7 or Fig. 8. Drill the hole at a slope so that the outside end is 1/2 inch (13 mm) lower than inside end to ensure optimal drainage. Refer to Fig. 12.

Side Piping

Remove the knockout in the unit and drill a 2.6 inch (65 mm) or 3.7 inch (95 mm) hole where the pipe penetrates the structure using the guides given above.

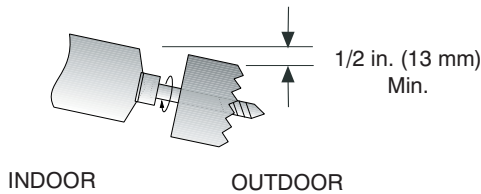

A07371

Fig. 12 – Drill Hole at Slope

NOTE: If the condensate pump accessory is to be used, the drain hose can be cut to provide space for the condensate pump reservoir in the back of the unit. The reservoir must be installed at this time. Please refer to installation instructions provided with the condensate pump accessory.

4. Place unit on a clean surface until you are ready to connect the piping and wiring.

INSTALL OUTDOOR UNIT

The outdoor units can be installed on the ground, on the roof, or mounted on a wall.

NOTE: Install the unit so that the coil does not face into prevailing winds. If this is not possible and constant winds above 25 mph are expected, use accessory wind baffle. See installation instructions provided with accessory kit. Wind baffles should also be used on all units with accessory low ambient temperature control.

Mounting on Ground

1. Mount unit on a solid level concrete pad.
2. If a heat pump is being installed, use a field- provided snow stand or ice rack where prolonged subfreezing temperatures or heavy snow occurs.
3. Position unit so water or ice from roof does not fall directly onto unit.
4. On cooling only units, an accessory stacking kit can be used when units are to be stacked. See installation instructions provided with the accessory kit.

Mounting on Roof

IMPORTANT: Mount unit on a level platform or frame at least 6 in. (152.4 mm) above roof surface. Isolate unit and tubing from structure.



CAUTION

PERSONAL INJURY AND/OR EQUIPMENT DAMAGE HAZARD

Failure to follow this caution may result in personal injury and/or equipment damage.

Be sure unit panels are securely in place prior to rigging.

1. Rig the unit. Keep the unit upright and lift using a sling. Use cardboard or padding under the sling, and spreader bars to prevent sling damage to the unit (see Fig 13). See Fig. NO TAG for center of gravity reference
2. Mount unit on a solid concrete pad or platform.
3. Isolate unit and piping from structure
4. If a heat pump is being installed, use a field- provided snow stand or ice rack where prolonged subfreezing temperatures or heavy snow occurs.
5. On cooling only units, an accessory stacking kit can be used when units are to be stacked. See installation instructions provided with accessory kit.

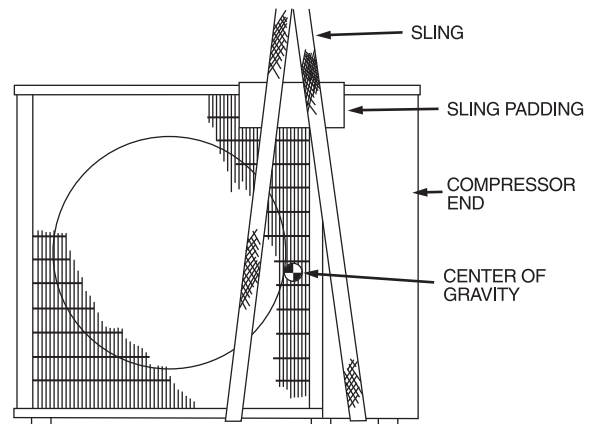

A07396

Fig. 13 – Lifting Unit with Sling

Mounting Unit on Wall

The units can also be mounted on the wall using the accessory mounting kit.

COMPLETE OUTDOOR REFRIGERANT CONNECTIONS

Follow the following general guidelines:

1. Use refrigerant grade field – supplied tubing. Refer to Table 10 for the correct line sizes.
2. Do not use less than 10 ft (93.05 m) of interconnecting tubing.



CAUTION

UNIT DAMAGE HAZARD

Failure to follow this caution may result in equipment damage or improper operation.

If any section of pipe is buried, there must be a 6 in. (152.4 mm) vertical rise to the valve connections on the outdoor unit. If more than the recommended length is buried, refrigerant may migrate to cooler, buried section during extended periods of system shutdown. This causes refrigerant slugging and could possibly damage the compressor at start-up.

When more than 80 ft (24.4 m) of interconnecting tubing is used, consult the Residential Long Line Application Guide for required accessories.

3. Insulate both lines. A minimum of 1/2 inch foam pipe insulation is recommended.
4. Run the refrigerant tubes as directly as possible and avoid unnecessary turns and bends.
5. Suspend refrigerant tubes to avoid damage to insulation or tubes so they do not transmit vibration to the structure.
6. When passing refrigerant tubes through the wall, seal the opening so rain and insects do not enter the structure. Leave some slack in refrigerant tubes between structure and outdoor unit to absorb vibration.

Connection at Outdoor Unit



CAUTION

UNIT DAMAGE HAZARD

Failure to follow this caution may result in equipment damage or improper operation.

To prevent damage to unit or service valves observe the following:

- A brazing shield **MUST** be used.
- Wrap service valves with wet cloth or use a heat sink material.

24AHA4/124ANS Units:

1. Assemble the connector tube to the factory supplied filter drier by:
 - a. Braze the field supplied connector to the inlet of the filter drier (see Fig. 14)

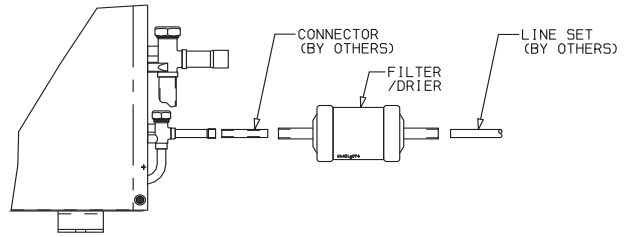

A09536

Fig. 14 – Cooling Only Connector Tube Assembly

2. Braze the completed filter drier assembly to the liquid service valve.
3. Connect the field supplied line set to the filter drier assembly and the suction valve. A sweat connection is required at the suction valve and flare connection is required for the mixed phase line.
4. Insulate any exposed areas between the line set and the liquid valve.

25HHA4/224ANS Units

1. Assemble the connector tubes to the factory supplied filter drier by brazing the factory supplied flare connectors to the inlet and outlet for the filter drier (see Fig. 15).

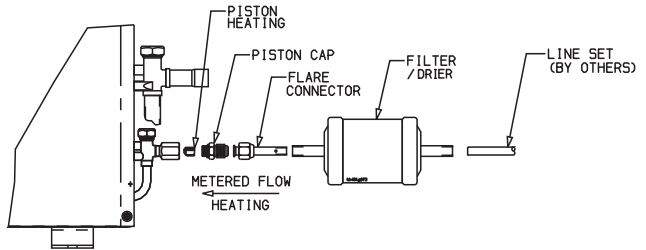

A09537

Fig. 15 – Heat Pump Connector Tube Assembly

2. Remove the plastic cap from the liquid and suction service valve on the heat pump outdoor unit and assemble the heating piston and piston cap supplied with the outdoor unit as shown in Fig. 16.

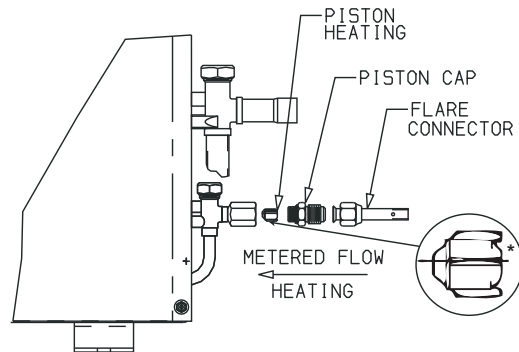

A07407

Fig. 16 – AccuRater (bypass type) Metering Device Components

NOTE: The Teflon seal on the piston should point towards the liquid service valve. The size of the factory supplied piston might have to be adjusted for long line applications (over 80 ft / 24.4 m). Refer to the Residential Long Line Application Guide for additional information.

3. Attach the flare end of the filter drier assembly to the piston cap (see Fig. 15).
4. Connect the field supplied line set to the filter drier assembly and to the suction valve.
5. Insulate any exposed areas between filter drier and liquid valve.

COMPLETE OUTDOOR POWER AND CONTROL WIRING

⚠ WARNING

Failure to follow this warning could result in personal injury or death.

The unit cabinet must have an uninterrupted or unbroken ground to minimize personal injury if an electrical fault should occur. The ground may consist of electrical wire or metal conduit when installed in accordance with existing electrical codes.

⚠ CAUTION

UNIT DAMAGE HAZARD

Failure to follow this caution may result in equipment damage or improper operation.

Unit failure as a result of operation on improper line voltage or excessive phase imbalance constitutes abuse and may cause damage to electrical components. Such operation could void any applicable manufacturer warranty.

⚠ WARNING

ELECTRICAL SHOCK HAZARD

Failure to follow this warning could result in personal injury or death.

Before performing service or maintenance, be sure indoor unit main power switch is turned OFF and indoor blower has stopped.

Lock out and tag switch with a suitable warning label.

Power Wiring

1. Mount outdoor power disconnect. The unit is factory wired for the voltage shown on the unit nameplate. The fused disconnect switch must be provided within sight of the unit, readily accessible, but out of reach of children. Provisions for locking the disconnect switch on the OFF (open) position is advisable. The disconnect switch must comply with NEC and local codes. Protect the unit and wiring using only the recommended fuse/circuit breaker size (see Tables 17 and 18).
2. Run power wiring from electric panel to disconnect per NEC and local codes.
3. Run power wiring from the disconnect switch to outdoor unit. Use only minimum 75°C copper conductors between the disconnect switch and the unit for field power connection.
4. Route the field power wires through the conduit connection opening in the unit side panel and connect in junction box as shown in Fig 17. The unit and power wiring must be grounded.

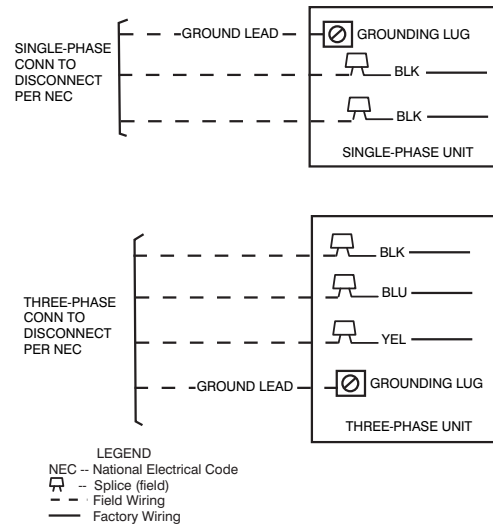

A08251

Fig. 17 – Line Power Connections

NOTE: Operating unit on improper line voltage constitutes abuse and may affect the manufacturer’s warranty. DO NOT install unit in a system where voltage may fluctuate above or below permissible limits.

Control Wiring

The indoor unit’s control circuit is 230 volts AC while the outdoor unit’s control circuit is 24 volts AC. The cooling only control voltage adapter kit (KAAVC0101AAA) is required in cooling only systems. The heat pump control voltage adapter kit (KHAVC0101AAA) is required in heat pump systems. The kit is installed in the outdoor unit.

1. Make sure you have enough control wires to cover the distance between the indoor and kit/ outdoor unit.
2. Route one end of the control wiring through the opening provided in the unit side panel and connect to the control terminal strip using either Fig. 18 for Cooling Only units and Fig. 19 for heat pump units. Detailed instructions on how to route wires can be found in the kit’s installation instructions.

Connection Diagrams

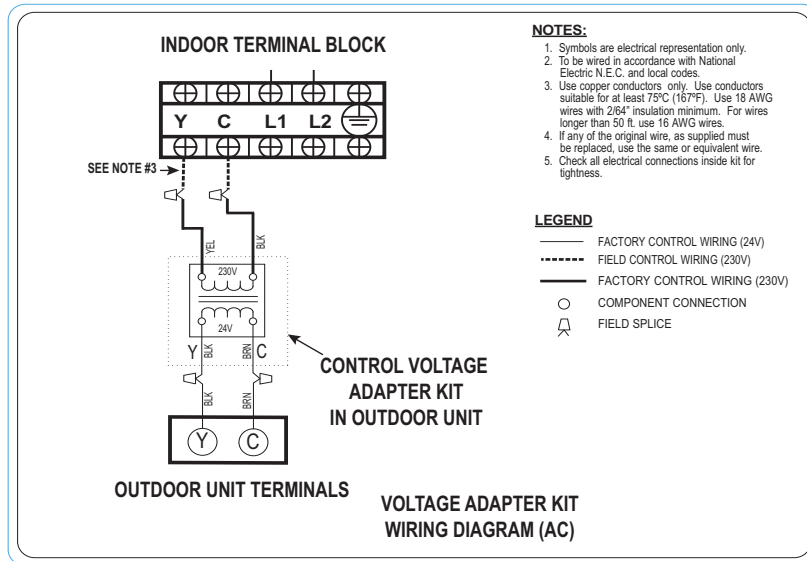

Fig. 18 – 40MKCB**B / 24AHA4 or 124ANS Connecting diagram

A150098

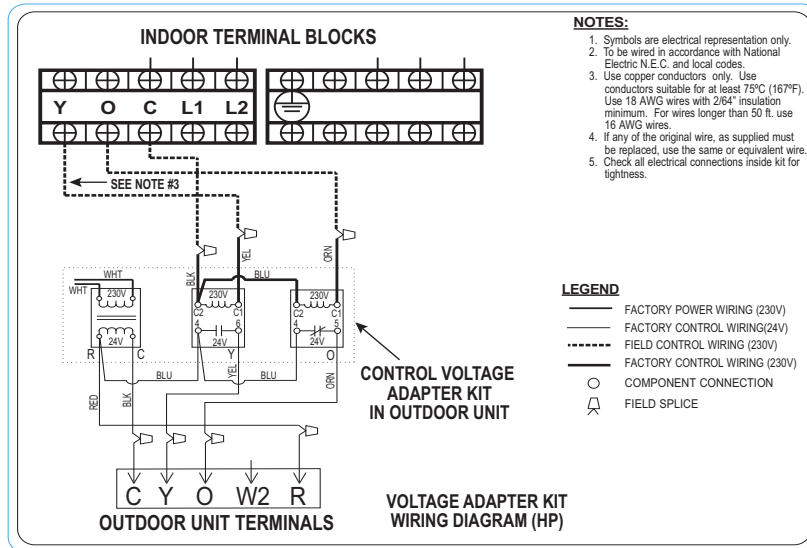

Fig. 19 – 40MKQB**B / 25HHA4 or 224ANS Connecting diagram

A150092

ELECTRICAL DATA

Table 17 – 24AHA4/124ANS Electrical Data

Unit Size - voltage series	V/PH	OPER VOLTS*		COMPR		FAN	MCA	MAX FUSE** or CKT BRK AMPS
		MAX	MIN	LRA	RLA	FLA		
18-30	208/230/1	253	197	56.3	9.0	0.50	11.8	20
24-30				62.9	10.9	0.50	14.1	25
30-30				73.0	14.1	0.70	18.3	30
36-30				77.0	14.1	1.20	18.8	30
36-50	208/230/3	253	197	71.0	9.0	1.20	12.5	20
36-60	460/3	506	414	38.0	5.6	0.60	7.6	15

Table 18 – 25HHA4/224ANS Electrical Data

Unit Size - voltage series	V/PH	OPER VOLTS*		COMPR		FAN	MCA	MAX FUSE** or CKT BRK AMPS
		MAX	MIN	LRA	RLA	FLA		
24-30	208/230/1	253	197	58.3	12.8	0.50	16.5	25
30-30				64.0	12.8	1.20	17.2	30

Table 19 – 40MKCBB Electrical Data**

40 MKCB**B Nominal tonnage size	Voltage	Voltage Range		Fan	Power	
		Min	Max	FLA	Min Ckt Amps	Fuse HACR Bkr Amps
018, 022	208/230---1---60	187	253	0.485	1.0	15
028, 032	208/230---1---60	187	253	0.51	1.0	15

Table 20 – 40MKQBB Electrical Data**

Heat Pump Unit Size	Voltage	Voltage Range		Fan	Power	
		Min	Max	FLA	Min Ckt Amps	Fuse HACR Bkr Amps
024, 028	208/230---1---60	187	253	0.51	1.0	15

LEGEND

FLA – Full Load Amps

HACR– Heating, Air Conditioning, Refrigeration

LRA– Locked Rotor Amps

NEC– National Electrical Code

RLA– Rated Load Amps (compressor)

*Permissible limits of the voltage range at which the unit will operate satisfactorily

****Time–Delay fuse.**

Complies with 2007 requirements of ASHRAE Standards 90.1

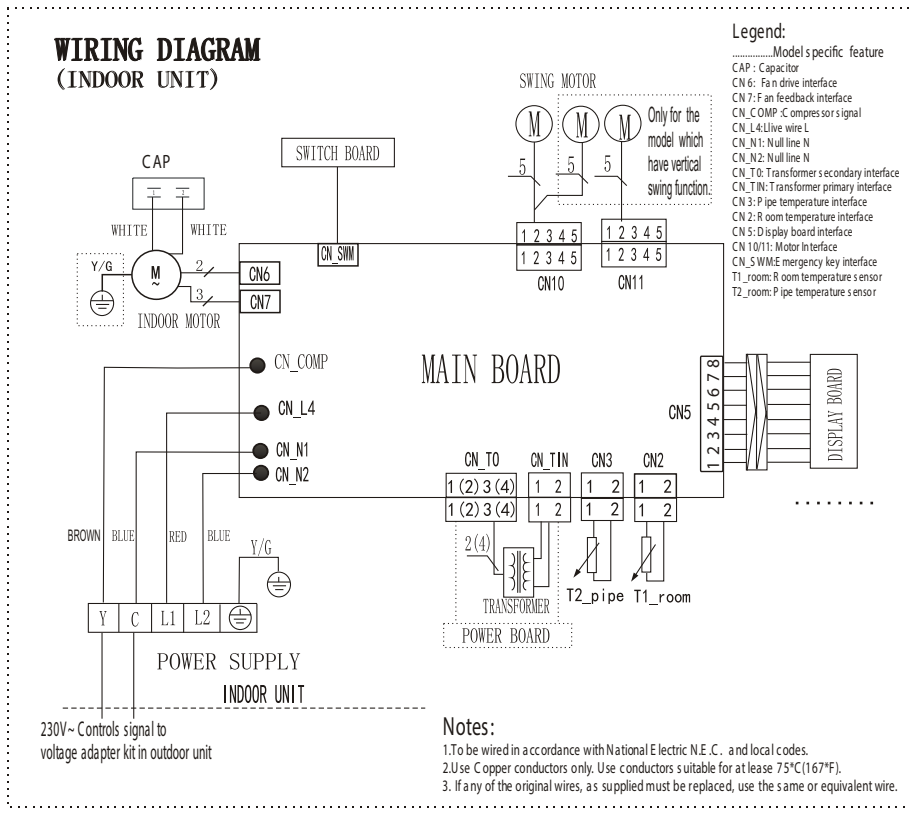

Fig. 20 – 40MKCB wiring diagram**

OUTDOOR UNIT SCHEMATIC DIAGRAM

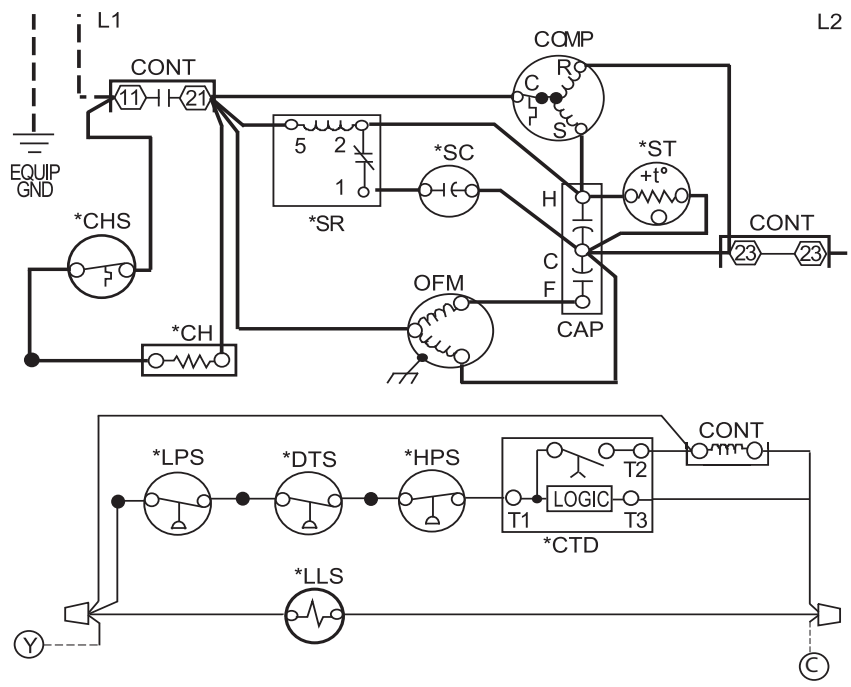

Fig. 21 – 24AHA4/124ANS Wiring Diagram

WIRING DIAGRAM (INDOOR UNIT)

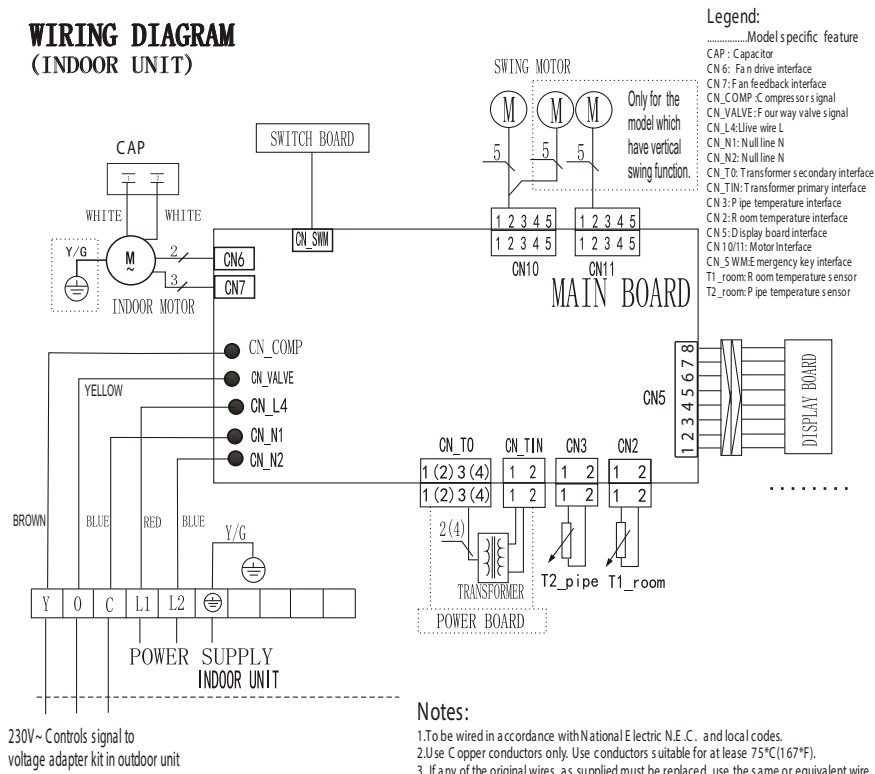

Fig. 22 – 40MKQ**B wiring diagram

OUTDOOR UNIT SCHEMATIC DIAGRAM

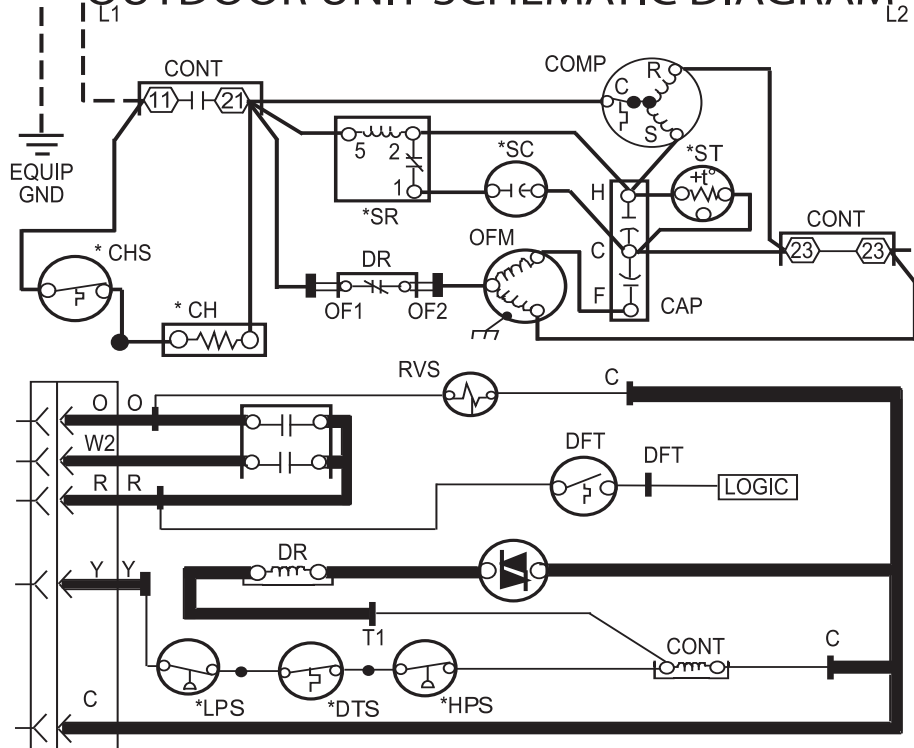

Fig. 23 – 25HHA4/224ANS Wiring Diagram

RUN POWER WIRING FOR INDOOR UNIT

Be sure field wiring complies with local building codes and NEC, and unit voltage is within limits shown in Tables 17 through 20.

Contact the local power company for correction of improper line voltage.



WARNING

ELECTRICAL SHOCK HAZARD

Failure to follow this warning could result in personal injury or death.

Before installing, modifying, or servicing system, main electrical disconnect switch must be in the OFF position. There may be more than 1 disconnect switch. Lock out and tag switch with a suitable warning label.



CAUTION

UNIT DAMAGE HAZARD

Failure to follow this caution may result in equipment damage or improper operation.

Unit failure as a result of operation on improper line voltage or excessive phase imbalance constitutes abuse and may cause damage to electrical components. Such operation could void any applicable manufacturer warranty.

NOTE: Use copper wire only between disconnect switch(es) and unit.

NOTE: Install branch circuit disconnect of adequate size to handle unit starting current per NEC. Locate disconnect within sight of, and readily accessible from, unit, per section 440-14 of NEC. Some codes allow indoor unit to share disconnect with outdoor unit if disconnect can be locked; check local code before installing in this manner.

The 40MKC(Q)**B units require their own power supply.

1. Locate the indoor power supply.
2. Locate and install disconnect switch per NEC and local codes.
3. Run power supply wiring to disconnect switch.
4. Run power wiring from disconnect switch to wall mount area.
5. If any accessories are being installed, refer to the individual accessory instructions for guidance on wire routing at this time.

Install All Power, Interconnecting Wiring, Piping and Drain Hose to Indoor Unit

1. Run the control wiring from the outdoor unit through the access hole in the wall and make sure you have enough wire to reach the control box of the unit once hung on the mounting plate.
2. It is recommended that flare connections is located on the outside of the wall where the indoor unit is to be mounted. If an extension pipe is required to facilitate this location, measure, fabricate and install the extension pipes to the indoor unit before hanging the unit on the mounting bracket.
3. If piping connections are on the outside wall, pass the pipes (refrigerant and drain) through the wall sleeve and then hook the indoor unit body on top of the wall hanging bracket. Support the unit away from the bottom using a tool or a piece of wood.

NOTE: Tie together the refrigerant piping, the drain hose, and the electrical connection wires and ensure that the drain hose is at the bottom as shown in Fig. 24.

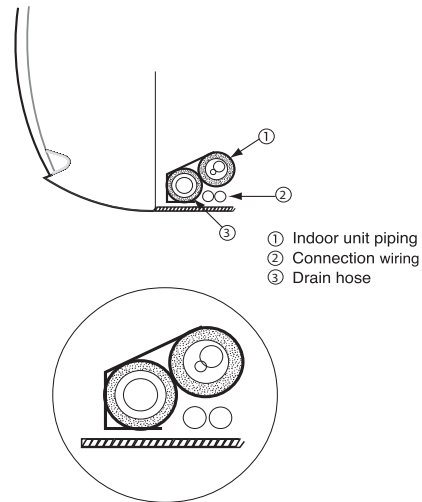

A08364

Fig. 24 – Location of Piping, Hose, and Wiring

4. If required make the flare connections.
5. Route the power and control wiring through the back side of the unit and to the control box area. If the wired remote is to be used, perform any modifications required at this time. Refer to the Accessory installation instructions.
6. Remove the control box cover and finish all indoor unit wiring connections as shown on the wiring diagram or in the accessory installation instructions. Replace the control box cover.
7. Fix the bottom part of the unit to the wall mounting bracket and push it carefully until the two bracket hooks fit into the marked places at the base of the unit until it snaps into place. See Fig.7 and Fig.8.
8. If the refrigerant piping connections are located outside the wall, tighten the flare connections as shown in Fig. 25. Insulate all exposed refrigerant lines and secure to the wall and fill any void spaces in the hole.

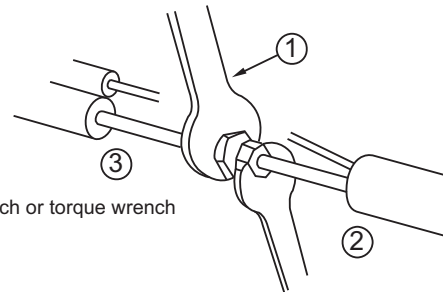

- ① Adjustable wrench or torque wrench
- ② Outdoor end
- ③ Indoor end

A07201

Fig. 25 – Tightening Connections

START-UP

PRELIMINARY CHECKS

1. Check condensate drainage system; on the opposite side of the drain connection, insert a water bottle up into the fan coil unit and fill the drain pan. Water must flow steadily; if not, check the pipe slope or inspect for any pipe restrictions.
2. Make sure all wiring connections are correct and they are tight.
3. Field electrical power source must agree with unit name plate rating.
4. Check that all barriers, covers, and panels are in place. Ensure that the filters and return--air grilles on the indoor unit have been installed and that the discharge louvers are positioned correctly.
5. All service valves must be closed.
6. On units with crankcase heaters, ensure belly--band heaters are tight around the compressor.

EVACUATE AND DEHYDRATE THE SYSTEM

⚠ CAUTION

UNIT DAMAGE HAZARD

Failure to follow this caution may result in equipment damage or improper operation.

Never use the system compressor as a vacuum pump.

Using Vacuum Pump

1. Completely tighten flare nuts A, B, C, D, connect manifold gage charge hose to a charge port of the low side service valve (see Fig. 26).
2. Connect charge hose to vacuum pump.
3. Fully open the low side of manifold gage (see Fig. 27).
4. Start vacuum pump
5. Evacuate using either deep vacuum or triple evacuation method.
6. After evacuation is complete, fully close the low side of manifold gage and stop operation of vacuum pump.
7. The factory charge contained in the outdoor unit is good for up to 25 ft. (8 m) of line length. For refrigerant lines longer than 25 ft (8 m), add charge, up to the maximum allowable length, as specified in the residential Long Line Application Guide.
8. Disconnect charge hose from charge connection of the low side service valve.
9. Fully open service valves B and A.
10. Securely tighten caps of service valves.

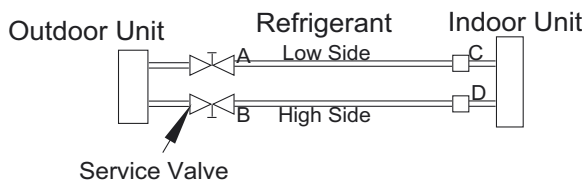

Fig. 26 – Service Valve

A07360

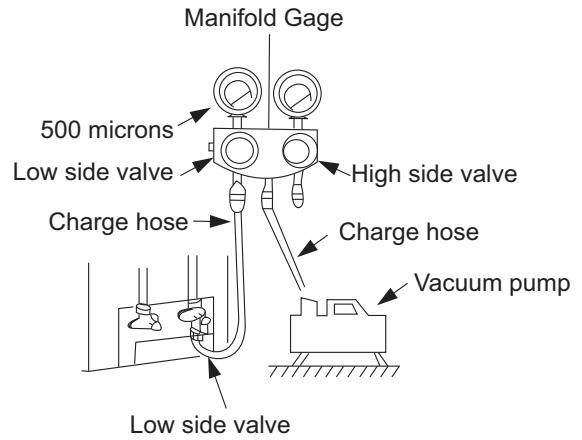

Fig. 27 – Manifold

A07361

Deep Vacuum Method

The deep vacuum method requires a vacuum pump capable of pulling a vacuum of 500 microns and a vacuum gage capable of accurately measuring this vacuum depth. The deep vacuum method is the most positive way of assuring a system is free of air and liquid water (see Fig. 28).

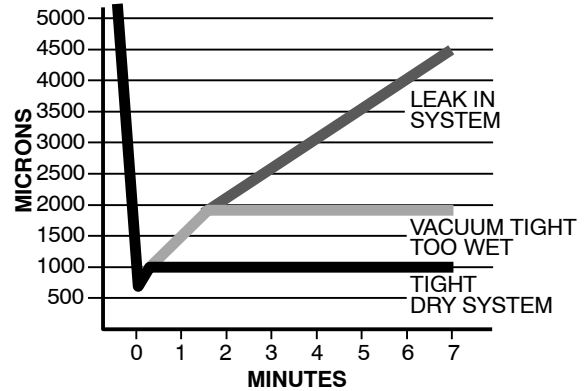

Fig. 28 – Deep Vacuum Graph

A95424

Triple Evacuation Method

The triple evacuation method should only be used when vacuum pump is only capable of pumping down to 28 in. of mercury vacuum and system does not contain any liquid water.

Refer to Fig. 29 and proceed as follows:

1. Pump system down to 28 in. of mercury and allow pump to continue operating for an additional 15 minutes.
2. Close service valves and shut off vacuum pump.
3. Connect a nitrogen cylinder and regulator to system and open until system pressure is 2 psig.
4. Close service valve and allow system to stand for 1 hr. During this time, dry nitrogen will be able to diffuse throughout the system absorbing moisture.
5. Repeat this procedure as indicated in Fig. 29. System will then be free of any contaminants and water vapor.

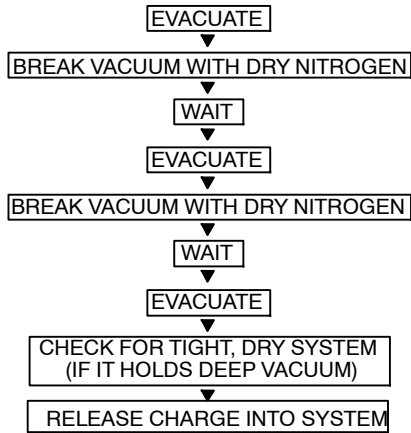

Fig. 29 – Triple Evacuation Method

A95425

TO START THE UNIT:

1. If the outdoor unit is equipped with a crankcase heater, turn on the indoor and outdoor disconnect switches to supply power to the system 6 hours before starting the system.
2. Release charge into the system by opening (back-seating) liquid and suction line service valves.
3. Set the wireless remote control or wired remote control below ambient temperature. Operate the unit for 15 minutes.
4. Refer to Table 12 to determine if additional charge is required. Also, if you have a long line application, refer to the Residential Long Line Application Guide to determine the additional charge that is required beyond 25 ft (7.6 m).
5. Calculate the total additional charge required and weigh in.
6. Charge should be added as liquid (not gas) slowly and carefully to low side to avoid liquid slugging.
7. Start unit with operation test. In test mode the unit will run in cooling and heating (on heat pumps) regardless if there is demand or not.

TEST OPERATION FOR HIGH WALL

Perform test operation after completing gas leak and electrical safety check (see Fig. 30).

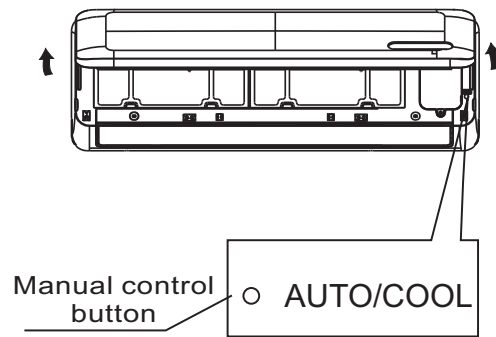

A14353

Fig. 30 – Test Operation

1. Push the ON/OFF button on the Remote Control to begin testing.

NOTE: A protection feature prevents the air conditioner from being activated for approximately 3 to 4 minutes.

2. Push the MODE button, select COOLING, HEATING, FAN mode to check if all functions work correctly.
3. To run the test using the manual button in the indoor unit:
 - a. Open front panel of the indoor unit;
 - b. Push the manual switch once to energize the unit. The set conditions of manual operation are as follows:
 - Preset set point: 76°F (24°C)
 - Fan speed: AUTO
 - Discharge air direction: Pre-set position based on operation in “Cool” or “Heat” mode.

4. Be sure to set manual switch to “OFF” (by pushing it twice again) after finishing test operation.

NOTE: For Heat Pumps, follow the same procedure.

SERVICE

⚠ WARNING

ELECTRICAL SHOCK HAZARD

Failure to follow this warning could result in personal injury or death. Before installing, modifying, or servicing system, main electrical disconnect switch must be in the OFF position. There may be more than 1 disconnect switch.

Lock out and tag switch with a suitable warning label.

Pump-down Procedure

The system may be pumped down in order to make repairs on the low side without losing complete refrigerant charge.

1. Attach pressure gage to suction service valve gage port.
2. Front-seat the mixed phase line valve.

 **WARNING**

UNIT DAMAGE HAZARD

Failure to follow this caution may result in equipment damage or improper operation. The unit coils hold only the factory-designated amount of refrigerant.

Additional refrigerant may cause units to relieve pressure through the compressor internal pressure relief valve (indicated by a sudden rise of suction pressure) before suction pressure reaches 20 psig.

If this occurs, shut off unit immediately then front-seat the suction valve and remove and recover excess refrigerant following accepted practices.

3. Start unit and run until suction pressure reaches 5 psig.
4. Shut unit off and front--seat suction valve.
5. Depressurize low side of unit and recover refrigerant following accepted practices.

Filter Drier

Whenever the filter drier is exposed to the atmosphere it must be replaced. Only use factory specified liquid-line filter driers with rated working pressures less than 600 psig.

NOTE: Do not install a suction-line filter drier in the mixed phase line.

REFRIGERANT CHARGING

 **WARNING**

PERSONAL INJURY AND/OR EQUIPMENT DAMAGE HAZARD

Failure to follow this warning could result in personal injury and/or equipment damage. Wear safety glasses and gloves when handling refrigerant. Do not overcharge system - this can cause compressor flooding.

All units are shipped with the refrigerant charge listed on nameplate.

NOTE: Do not vent or depressurize unit refrigerant to atmosphere. Remove and recover refrigerant following accepted practices.

TROUBLESHOOTING

FAULT CODE

For ease of service, the indoor unit is equipped with diagnostic code display LEDs in the indoor units. This diagnostic display is a combination of flashing LEDs on the display panel or the front of the unit. If possible, always check the diagnostic codes displayed on the indoor unit. The diagnostic codes displayed in the indoor unit are listed in table 21.

Once a failure occurs with the indoor unit in operation, the green LED on the indoor unit flashes at intervals of 0.5 seconds. The fault code is deduced from the number of times the green LED flashes, blocking unit operation. Between one flash cycle and the next one, a pause of 3 to 4 seconds elapses.

Table 21 – Diagnostic Codes

Operation lamp	Timer lamp	Display	LED STATUS
★ 1 time	X	E1	Indoor Unit EEPROM parameter error
★ 2 times	X	E2	Zero-crossing signal detection error
★ 3 times	X	E3	Indoor fan speed has been out of control
★ 5 times	X	E5	Open circuit or short circuit of indoor room temperature sensor
★ 6 times	X	E6	Open circuit or short circuit of evaporator coil temperature sensor
★ 2 times	O	EC	Refrigerant Leakage Detection

O (light) X (off) ★ (flash)

For additional diagnostic information, refer to the Service Manual.

Table 22 – Troubleshooting

PROBLEM	POSSIBLE CAUSE	SOLUTION
Compressor and Fan of the Outdoor Unit Will Not Start	Unit not energized	Check the main power connection.
	Main switch is set to OFF	Check and put it to ON position.
	Main switch fuses are blown	Replace fuses.
	Compressor cycling protection is on	Wait for 3 minutes.
	Main power voltage is too low	Check and set to the correct voltage.
Compressor Will Not Start, But Outdoor Fan is Operating	Electrical connections of compressor are loose or wrong	Check and tighten or repair compressor.
	Compressor burnt out; seized or protection device on	Check for the cause and replace compressor if necessary.
Compressor Stops Due to Over-temperature	Wrong refrigerant charge in unit (excessive or low) or air or other non-condensable gasses in the circuit	Drain refrigerant, evacuate and recharge. CAUTION: Do not vent refrigerant to the atmosphere; use refrigerant recovery equipment.
	Main voltage is too high or too low	Check voltage setting and adjust if necessary.
	Condenser coil obstructed	Remove obstruction.
	Outdoor fan off	Check cause and resume operation or repair.
	Wrong indoor unit thermistors	Replace thermistors.
	Refrigerant circuit clogged	Check and remove obstructions.
	Reversing valve faulty on heat pump models	Replace reversing valve.
Compressor Runs Continuously	Expansion device clogged or covered with ice	Drain refrigerant, evacuate and recharge. CAUTION: Do not vent refrigerant to the atmosphere; use refrigerant recovery equipment.
	Unit selected is too small for application requirements	Contact a qualified service technician for a system evaluation.
	Indoor temperature setting too low or too high	Check temperature setting.
	Outdoor unit fan faulty	Replace outdoor fan.
	Air or other non-condensable gasses in the circuit	Drain refrigerant, evacuate and recharge. CAUTION: Do not vent refrigerant to the atmosphere; use refrigerant recovery equipment.
Frequent Ice-Build-Up on Outdoor Coil	Obstructions at air intake or dirty indoor unit filters	Remove obstruction and/or clean filter.
	Outdoor fan is stopped	Check cause and repair.
Discharge Pressure Too High	Outdoor coil dirty or obstructed	Clean or remove obstructions.
	Condenser fan faulty	Replace condenser fan.
	Indoor temperature setting too low or too high	Check temperature setting.
	Air or other non-condensable gasses in the circuit	Drain refrigerant, evacuate and recharge. CAUTION: Do not vent refrigerant to the atmosphere; use refrigerant recovery equipment.
Discharge Pressure Too Low	Indoor temperature setting too high or too low	Check temperature setting.
	Outdoor coil dirty or obstructed	Clean or remove obstructions.
	Indoor unit air filter dirty	Clean filter.
Suction Pressure Too High	Indoor temperature setting too high or too low	Check temperature setting.
	Reversing valve faulty or internal leak	Replace reversing valve.
Suction Pressure Too Low	Indoor temperature setting too high or too low	Check temperature setting.
	Evaporator coil covered with ice	Air circulation on the evaporator not sufficient; check and repair.
	Expansion device or suction line clogged	Check and repair.
	Outdoor fan does not stop during defrost periods	Check electrical parts.
Outdoor Fan Cycling Due to Over-Temperature Protection	Electrical connection loose	Check connections.
	Fan motor burn out	Replace.
	Fan bearing seized	Check and repair.
	Expansion device clogged or covered with ice	Drain refrigerant, evacuate and replace. CAUTION: Do not vent refrigerant to the atmosphere; use refrigerant recovery equipment.

NOTE: For additional diagnostic information, refer to the “Service Manual”.