

Installation and Maintenance Instructions

CONTENTS	Page
SAFETY CONSIDERATIONS	1, 2
GENERAL	2-4
INSTALLATION	5-13
Step 1 — Unpack and Inspect Units	5
• PROTECTING UNITS FROM DAMAGE	
• PREPARING JOBSITE FOR UNIT INSTALLATION	
• IDENTIFYING AND PREPARING UNITS	
Step 2 — Position the Unit	5
Step 3 — Install Ductwork	6
• UPFLOW INSTALLATION	
• HORIZONTAL INSTALLATIONS	
• DUCT CONNECTIONS	
• DUCTWORK ACOUSTICAL TREATMENT	
Step 4 — Connect Piping	6
• CONDENSATE PIPING	
• REFRIGERANT PIPING	
Step 5 — Complete Electrical Connections	7
Step 6 — Position and Connect Controller	7
• CONTROL WIRING	
• OPTION/EXTENSIONS OF COMMUNICATION WIRING	
ACB (Auxiliary Control Board) Interface	13
START-UP	13
Pre-Start Check	13
System Operation Check	13
MAINTENANCE	13
INDOOR UNIT ADDRESSING	13-14
Wireless Remote Controller (40VM900001)	13
Non-Programmable Controller (40VM900002) ..	14
Programmable Controller (40VM900003)	14
TROUBLESHOOTING	15, 15
Replacement Parts	16
APPENDIX A — DIP SWITCH SETTINGS	17
APPENDIX B — FAN CURVES	18, 18

SAFETY CONSIDERATIONS

Improper installation, adjustment, alteration, service, maintenance, or use can cause explosion, fire, electrical shock, or other conditions which may cause death, personal injury or property damage. The qualified installer or agency must use factory authorized kits or accessories when modifying this product.

Follow all safety codes. Wear safety glasses, protective clothing, and work gloves. Use quenching cloth for brazing operations. Have fire extinguisher available. Read these instructions thoroughly and follow all warnings or cautions included in literature and attached to the unit. Consult local building codes and the current editions of the National Electrical Code (NEC) ANSI/NFPA (American National Standards Institute/National Fire Protection Association) 70. For Canada, refer to the current editions of the Canadian Electrical Code CSA (Canadian Standards Association) C22.1.

Understand the signal words — DANGER, WARNING, and CAUTION. DANGER identifies the most serious hazards,

which will result in severe personal injury or death. WARNING signifies hazards that could result in personal injury or death. CAUTION is used to identify unsafe practices, which could result in minor personal injury or product and property damage.

Recognize safety information. This is the safety-alert symbol (⚠). When this symbol is displayed on the unit and in instructions or manuals, be alert for the potential of personal injury. Installing, starting up, and servicing the equipment can be hazardous due to system pressure, electrical components, and equipment location.

⚠ WARNING

Electrical shock can cause personal injury and death. Shut off all power to this equipment during installation. There may be more than one disconnect switch. Tag all disconnect locations to alert others not to restore power until work is completed.

⚠ WARNING

When installing the equipment in a small space, provide adequate measures to avoid refrigerant concentration exceeding safety limits due to refrigerant leak. In case of refrigerant leak during installation, ventilate the space immediately. Failure to follow this procedure may lead to personal injury.

⚠ WARNING

DO NOT USE TORCH to remove any component. System contains oil and refrigerant under pressure.

To remove a component, wear protective gloves and goggles and proceed as follows:

- a. Shut off electrical power to unit.
- b. Recover refrigerant to relieve all pressure from system using both high pressure and low pressure ports.
- c. Traces of vapor should be displaced with nitrogen and the work area should be well ventilated. Refrigerant in contact with an open flame can produce toxic gases.
- d. Cut component connection tubing with tubing cutter and remove component from unit. Use a pan to catch any oil that may come out of the lines and as a gage for how much oil to add to the system.
- e. Carefully unsweat remaining tubing stubs when necessary. Oil can ignite when exposed to torch flame.

Failure to follow these procedures may result in personal injury or death.

GENERAL

⚠ CAUTION

DO NOT re-use compressor oil or any oil that has been exposed to the atmosphere. Dispose of oil per local codes and regulations. DO NOT leave refrigerant system open to air any longer than the actual time required to service the equipment. Seal circuits being serviced and charge with dry nitrogen to prevent oil contamination when timely repairs cannot be completed. Failure to follow these procedures may result in damage to equipment. For information about replacement oil type and viscosity, see the Installation, Start-Up, and Service Instructions for the 38VMAH and 38VMAR outdoor units.

The 40VMV vertical AHU (air-handling unit) is equipped with a DC motor. The unit features dual drain spouts so it can be mounted vertically or horizontally, and is ideal for closet applications. Through thermostatic control of operations, conditions can be varied to suit diverse requirements and activities.

The equipment is initially protected under the manufacturer's standard warranty; however, the warranty is provided under the condition that the steps outlined in this manual for initial inspection, proper installation, regular periodic maintenance, and everyday operation of the unit be followed in detail. This manual should be fully reviewed in advance before initial installation, start-up and any maintenance. Contact your local sales representative or the factory with any questions BEFORE proceeding.

Table 2 lists physical data for each unit size. See Fig. 1 for model number nomenclature. Fig. 2 shows unit dimensions. Table 1 shows components that may or may not be used for a particular installation.

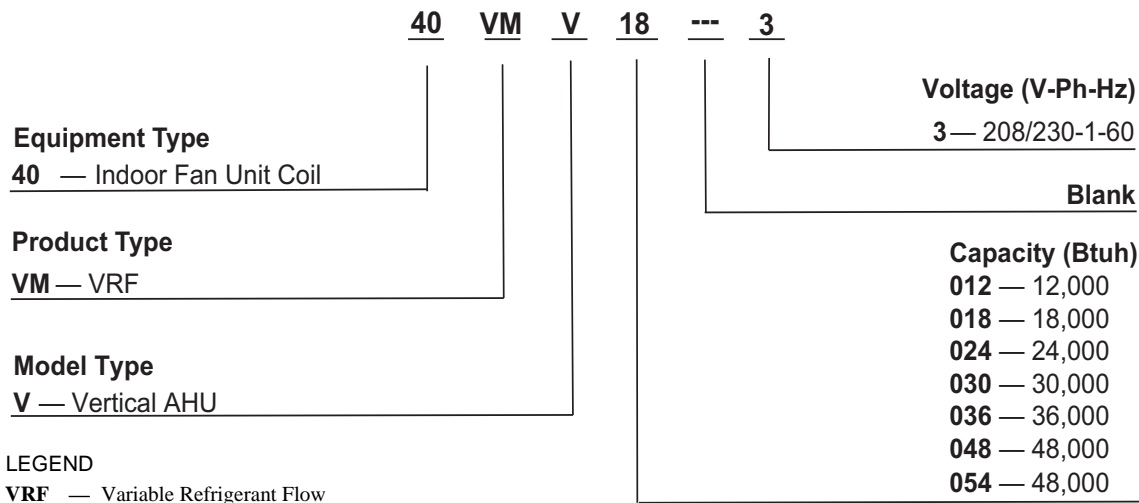



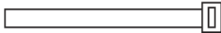

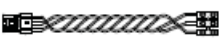
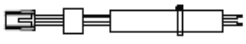

Fig. 1 — Model Number Nomenclature

Table 1 — Components Shipped With Unit

NAME	SHAPE	QUANTITY	FUNCTION
Copper pipes		2	Reducer for smaller pipe diameter (only for size 018 unit).
Drain plug		2	Plug the drain pan outlet
Wire grommet		2	For wire routing
Tie rope		3	_____
Screw		4	_____
PQ connection wire		2	To connect the outdoor unit, indoor unit and sub MDC.
Connecting wire		1	For occupancy sensor

LEGEND

MDC — Multiport Distribution Controller

Table 2 — 40VMV Physical Data

UNIT 40VMV	012	018	024	030	036	048	054
POWER SUPPLY (V-Ph-Hz)	208/230-1-60						
COOLING CAPACITY (Btuh)	12,000	18,000	24,000	30,000	36,000	48,000	53,500
HEATING CAPACITY (Btuh)	13,500	21,000	27,000	34,000	40,000	54,000	60,000
INDOOR FAN MOTOR							
Type	DC Motor						
Input (W)	43	60	100	151	187	355	466
INDOOR COIL							
Number of Rows	3	4					
Fin Spacing (fins/in.)	16				17		
Fin Type	Hydrophilic Aluminum						
Tube Diameter, OD (in.)	0.276						
Tube Type	Inner Groove						
Number of Circuits	6	8			12		
INDOOR AIRFLOW (cfm)							
Low	320	420	560	700	840	1120	1260
Medium	320	510	680	850	1020	1360	1530
High	400	600	800	1000	1200	1600	1800
EXTERNAL STATIC PRESSURE (in. wg)	0.8						
INDOOR UNIT NOISE LEVEL (dBA)							
Low	34.5	34.4	37.9	44.4	39.3	43.8	47.9
Medium	34.5	37.1	42.3	48.4	44.1	48.5	52.6
High	37.6	41.6	46.2	52.2	46.9	53.0	57.1
UNIT							
Unit Dimensions, W x H x D (in.)	19-5/8 x 46-1/2 x 20-5/8				22 x 54-1/2 x 24		
Packing Dimensions, W x H x D (in.)	22-5/8 x 50-5/8 x 25-3/8				24-5/8 x 58-5/8 x 27-3/4		
Net/Gross Weight (lb)*	119/143	123/147			163/189		
REFRIGERANT TYPE	R-410A						
THROTTLE	EEV						
DESIGN PRESSURE (psig)	580/320						
REFRIGERANT PIPING (in.)							
Liquid Side, OD	1/4	3/8					
Gas Side, OD	1/2	5/8					
CONNECTING WIRING (AWG)							
Power Wiring	Sized per NEC and local codes based on nameplate electrical data						
Signal Wiring	2-core stranded shielded twisted pair cable 16-20 AWG						
CONDENSATE DRAIN PIPE DIAMETER, OD (in.)	3/4 NPT						

LEGEND

- AWG** — American Wire Gage
- EEV** — Electronic Expansion Valve
- NEC** — National Electric Code

*Gross weight includes packaging.

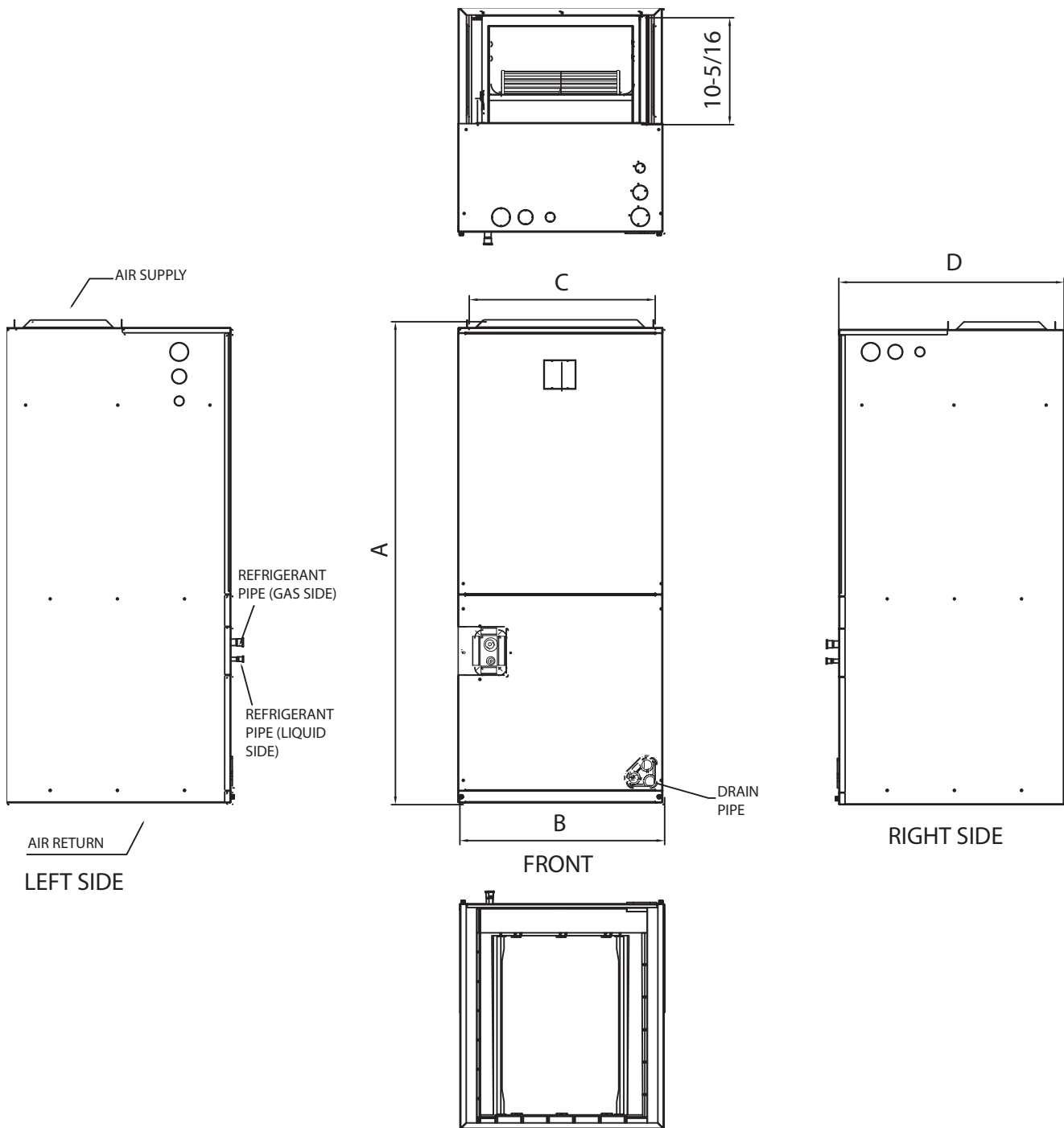

40VMV UNIT SIZE	A	B	C	D
012-030	46 1/2	19 5/8	18	21 5/8
036-054	54 1/2	22	19 1/2	24

NOTE: All dimensions shown in inches.

Fig. 2 — 40VMV012-054 Dimensions

INSTALLATION

Step 1 — Unpack and Inspect Units Units are packaged for shipment to avoid damage during normal transit and handling. It is the receiving party's responsibility to inspect the equipment upon arrival. Any obvious damage to the carton and/or its contents should be reported on the bill of lading and a claim should be filed with the transportation company and the factory. Unit should always be stored in a dry place, and in the proper orientation as marked on the carton.

⚠ CAUTION

To avoid equipment damage, do not lift unit by the drain pipe or refrigerant piping. Unit should be lifted using the mounting brackets.

After determining the condition of the carton exterior, carefully remove each unit from the carton and inspect for hidden damage. Check to make sure that items such as thermostats, controller etc. are accounted for, whether packaged separately or shipped at a later date. Any hidden damage should be recorded, a claim should be filed with the transportation company, and the factory should be notified. In the event a claim for shipping damage is filed, the unit, shipping carton, and all packing must be retained for physical inspection by the transportation company. All units should be stored in the factory shipping carton with internal packaging in place until installation.

PROTECTING UNITS FROM DAMAGE Do not apply force or pressure to the coil, piping, or drain stub-outs during handling. All units should be handled by the chassis or as close as possible to the unit mounting point locations.

The unit must always be properly supported. Temporary supports used during installation or service must be adequate to hold the unit securely. To maintain warranty, protect units against hostile environments (such as rain, snow or extreme temperature), theft, vandalism, and debris on jobsite. Equipment covered in this manual is not suitable for outdoor installations. Do not allow foreign material to fall into drain pan. Prevent dust and debris from being deposited on motor, fan wheels and coils. Failure to do so may have serious adverse effects on unit operation and in the case of motor and blower assembly, may result in immediate or premature failure. Failure of any unit caused by deposits of foreign material on the motor or blower wheels will not be covered by the manufacturer's warranty. Some units and/or job conditions may require some form of temporary covering during construction.

PREPARING JOBSITE FOR UNIT INSTALLATION To save time and to reduce the possibility of costly errors, set up a complete sample installation in a typical room at jobsite. Check all critical dimensions such as pipe, wire, and duct connections requirements. Refer to job drawings and product dimension drawings as required. Instruct all trades in their parts of the installation. Units must be installed in compliance with all applicable local code requirements.

IDENTIFYING AND PREPARING UNITS Be sure power requirements match available power source. Refer to unit nameplate and wiring diagram. In addition:

- Check all tags on unit to determine if shipping screws are to be removed. Remove screws as directed.
- Rotate the fan wheel by hand to ensure that the fan is unrestricted and can rotate freely. Check for shipping damage and fan obstructions. Adjust blower motor as required.

Step 2 — Position the Unit

⚠ DANGER

Units must not be installed where they may be exposed to potentially explosive or flammable atmosphere. If this instruction is not followed exactly, a fire or explosion may result, causing property damage, injury, or loss of life.

Install the unit in a location that meets the following requirements:

- Allow adequate space for installation, service clearance, piping and electrical connections, and necessary ductwork. For specific unit dimensions, refer to Table 2, Fig. 2, and Fig. 3. Allow clearance according to local and national codes.
- Unit can be installed standing vertically on the floor or on a field-provided stand. If a stand is used, be sure it can support the weight of the unit. Unit can also be installed horizontally, either resting on the floor or suspended from the ceiling. If suspended, confirm that the ceiling is able to support the weight of the unit. See Table 2 for nominal weight.
- If the unit is to be installed over a finished ceiling and/or living area, building codes may require a field-supplied secondary condensate drain pan to be installed under the entire unit. Consult local codes inspector for additional information.

Select the unit position with the following points in mind:

- The unit should be installed on a structure that is suitable to support the total weight of the unit, refrigerant piping and condensate.
- Proper access should be provided for maintenance for refrigerant piping, EEV (electronic expansion valve), electrical box, and condensate pump. A 2-ft. clearance is recommended all around the unit.
- The unit should not be positioned close to a wall or similar obstruction, or in a position where the discharge air could blow directly on the thermostat. See Fig. 3.
- The unit should not be positioned directly above any obstruction.
- The unit must be installed square and level.
- The condensate drain should have sufficient downward slope (1 in. per 100 in.) in any horizontal run between unit and drain.

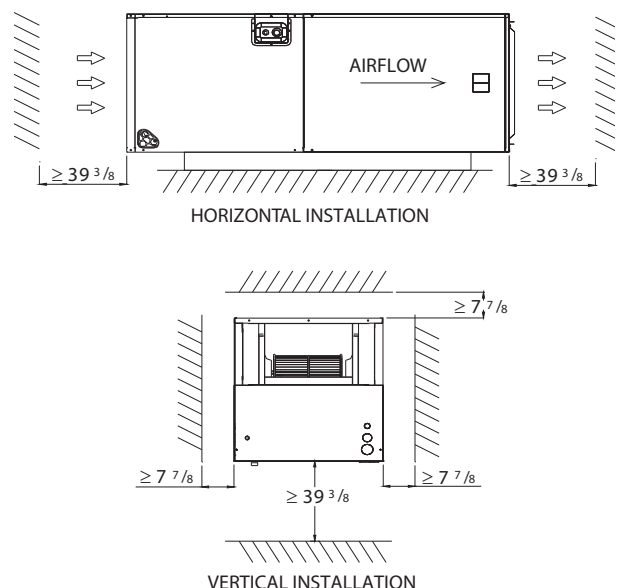

NOTE: All dimensions shown in inches.

Fig. 3 — Clearances

IMPORTANT: If the unit is installed in the ceiling, be sure that the ceiling grid is supported separately from the unit. The ceiling grid must not be supported by any part of the unit, grille, or any associated wiring or piping work.

Step 3 — Install Ductwork

UPFLOW INSTALLATION If return air is to be ducted, install duct flush to the floor. Only use the return-air opening provided. All return air must pass through the coil.

HORIZONTAL INSTALLATIONS Be sure installation complies with all applicable building codes, which may require installation of a secondary condensate pan.

NOTE: To ensure proper drainage for horizontal installations, unit must be installed so it is within 1/8-in. pitch of the length and width of the unit.

1. Arrange support for unit by setting it in or above secondary condensate pan.
2. When suspending unit from ceiling, dimples in casing indicate proper location of screws for mounting metal support straps.

DUCT CONNECTIONS Connect supply-air duct over outside of 3/4-in. flange provided on supply-air opening. Secure duct to flange with proper fasteners for type of duct used, and seal duct-to-unit joint.

Duct connection flanges are provided at the discharge air unit connection.

Use flexible connectors between ductwork and unit to prevent transmission of vibration. Ductwork passing through unconditioned space must be insulated and covered with vapor barrier.

DUCTWORK ACOUSTICAL TREATMENT Metal duct systems that do not have a 90-degree elbow and 10 ft of main duct to first branch takeoff may require internal acoustical insulation lining.

As an alternative, fibrous ductwork may be used if constructed and installed in accordance with the latest edition of SMACNA (Sheet Metal and Air-Conditioning Contractors' National Association) construction standard on fibrous glass ducts. Both acoustical lining and fibrous ductwork shall comply with National Fire Protection Association Standards 90A or B as tested by UL (Underwriters Laboratories) Standard 181 for Class 1 air ducts.

Step 4 — Connect Piping

CONDENSATE PIPING The unit is supplied with a 3/4-in. female pipe thread drain connection to connect drain piping. When installing the unit, follow these recommendations:

- Condensate piping should slope downward in the direction of condensate flow, with a minimum gradient of 1 in. per 100 inches.
- Condensate piping should be installed in such a way that it does not block the front service panel.
- A drain trap may be required by local codes and is recommended for odor control.
- The differential height between inlet and outlet should be at least 3 inches. The differential height between the

bottom of the trap and outlet should also be 3 inches. See Fig. 4.

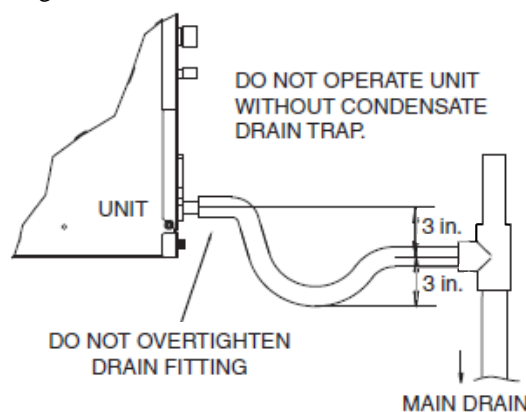

Fig. 4 — Condensate Drain Trap

- Auxiliary drain should be connected and run to a location where it is easily visible when it becomes active, suggesting a problem with the main drain system.
- When multiple units are connected to a common condensate drain, ensure that the drain is large enough to cope with the volume of condensate from all units. It is also recommended to have an air vent in the condensate piping to prevent air locks.
- Insulate the drain line to prevent sweating and provide proper support to prevent undue stress.
- Condensate piping must not be installed where it may be exposed to freezing temperatures.

REFRIGERANT PIPING

⚠ CAUTION

When connecting from an indoor unit to an outdoor unit, the isolation valve at the outdoor unit should be in the closed position throughout the refrigerant piping process. Failure to follow this procedure may result in equipment damage.

When connecting from an indoor unit to an outdoor unit, follow these procedures:

- Check for maximum height drop and length of refrigerant piping between the indoor and outdoor unit. If the difference is more than 33 ft, consider mounting the outdoor unit above indoor unit.
- Refrigerant piping connection between indoor and outdoor units should be performed once the units are secured at their respective installation locations.
- The refrigeration piping starts at the indoor unit and ends at the outdoor unit.
- The number of bends in the refrigeration piping must be fewer than 15.
- The refrigerant piping should be dry and free of dust and other contaminants.
- The bending angle of the refrigerant pipe should not exceed 90 F and the bending radius should be as large as possible to prevent any breakage in piping.
- Use proper cutting and flaring tools to avoid leakage.
- Use a torque wrench for flare nuts. Refer to Table 3 for flare nut torque recommendations.

Table 3 —Flare Nut Torque Recommendations

Outside Diameter (in.)	Recommended Torque (ft-lb)
1/4	15
3/8	26
1/2	41
5/8	48

- Before insulating the suction and liquid refrigeration pipes, perform pressure and leak tests. For details, see the outdoor unit installation manual. Insulating both suction and liquid refrigerant pipes is required.
- Vacuuming and charging of the system should be carried out as described in the outdoor unit installation manual.

Step 5 — Complete Electrical Connections

Installation of wiring must conform with local building codes, or in the absence of local codes, with the National Electric Code ANSI/NFPA 70, current editions. Units must be electrically grounded in conformance with the code. In Canada, wiring must comply with CSA C22.1, Electrical Code.

⚠ WARNING

Electrical shock can cause personal injury and death. Disconnect power supply before making wiring connections. There may be more than one disconnect switch. Tag all disconnect locations to alert others not to restore power until work is completed.

⚠ WARNING

All units must be wired strictly in accordance with the wiring diagram furnished with the unit. Any wiring different from the wiring diagram could result in personal injury and property damage.

⚠ CAUTION

Any original factory wiring that requires replacement must be replaced with wiring material having a temperature rating of at least 221 F.

Ensure supply voltage to the unit, as indicated on the serial plate, is not more than 10% over the rated voltage or 10% under the rated voltage.

Failure to follow these recommendations may result in equipment damage.

This equipment in its standard form is designed for an electrical supply of 208/230-1-60. Any damage to or failure of units caused by incorrect wiring or voltage is not covered by warranty.

Electric wiring must be sized to carry the full load amp draw of the motor, starter, and any other controls that are used with the unit. See Table 4 for electrical data.

Table 4 — 40VMV Electrical Data

40VMV UNIT SIZE	POWER SUPPLY	
	MCA	MOPD
012	1.5	15
018	3.8	15
024	3.8	15
030	3.8	15
036	5.3	15
048	5.3	15
054	7.2	15

LEGEND

MCA — Minimum Circuit Amps
MOPD — Maximum Overcurrent Protective Device



After the pipe work is complete, the electrical supply can be connected by routing the cable through the appropriate casing holes or knockouts and connecting the supply and ground cables to the unit's power terminal.

Be sure the power wiring and control wiring do not cross, as this might cause disturbance on the controls side. See Fig. 5 for wiring diagram.

NOTE: The indoor unit requires its own power supply. Indoor units are not powered from outdoor units.

Step 6 — Position and Connect Controller

NOTE: Controllers are ordered separately.

Wired controllers should be installed in a position that maintains good temperature control:

- Position the thermostat approximately 48 in. above floor level.
- Do not position thermostat where it can be directly affected by the unit's discharge airstream.
- Avoid external walls and drafts from window and doors.
- Avoid positioning near shelves and curtains as these restrict air movement.
- Avoid heat sources such as direct sunlight, heaters, dimmer switches, and other electrical devices
- See Fig. 6 and Fig. 7.

CONTROL WIRING

1. Use copper core PVC insulated sheathed shielded twisted cord.
2. For indoor and outdoor unit communication, use 'P, Q' terminals. Shielded core should be used for ground.
3. Wiring should be done according to wiring diagram.
4. Communication wire must not form a closed loop.
5. Use separate conduit for power and control wiring.

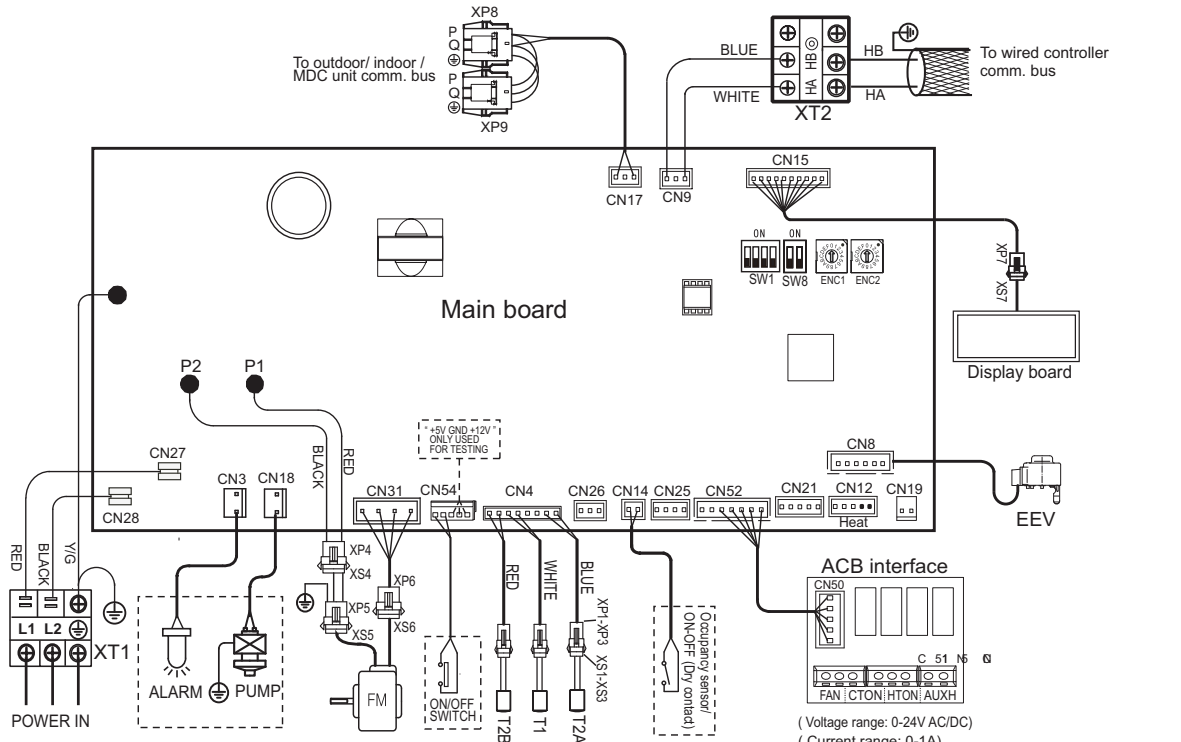

LEGEND

- ALAR** — Warning lamp (optional)
- M** — Output for Auxiliary Heat
- AUXH** — Output for Cooling Operation
- CTON** — Output for Heating Operation
- EEV** — Electronic Expansion Valve
- FAN** — Output for Fan Operation
- FM** — Indoor Fan Motor
- HTON** — Output for Heating Operation
- MDC** — Multiport Distribution Controller
- PUMP** — Pump Motor
- T1** — Room Temperature Sensor
- T2A** — Inlet Pipe Temperature Sensor
- T2B** — Evap. Outlet Temperature in Cooling Mode
- XP1-9** — Connectors
- XS1-7** — Connectors
- XT1-2** — Terminal Block
- Optional Component or Field Wiring

Fig. 5 — 40VMV012-054 Typical Wiring Diagram

OPTION/EXTENSIONS OF COMMUNICATION WIRING To extend control wiring or make terminal connections, use the PQ connection wire supplied in the accessory kit and follow the steps below.

1. Cut the connector on the outdoor unit side as shown in Fig. 7.

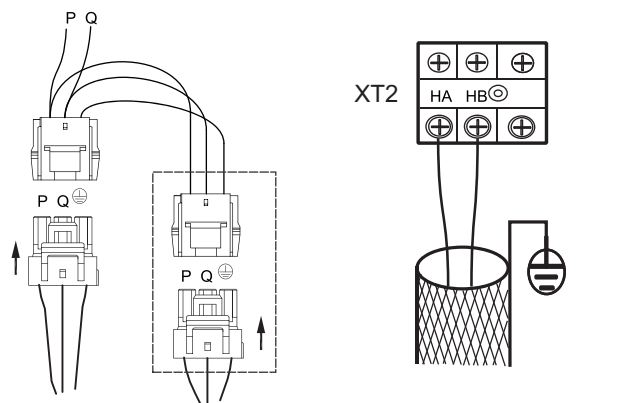

Fig. 6 — Communication Wire Connection

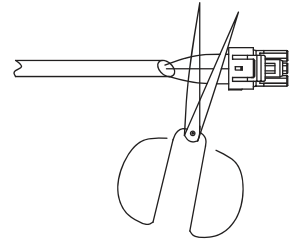

Fig. 7 — Shearing Outdoor Connector

- Strip a suitable length of the insulation layer as shown in Fig. 8.



Fig. 8 — Stripping the Wire

- Use a suitable screwdriver to fix the communication wire on the outdoor unit communication terminal as shown in Fig. 9.

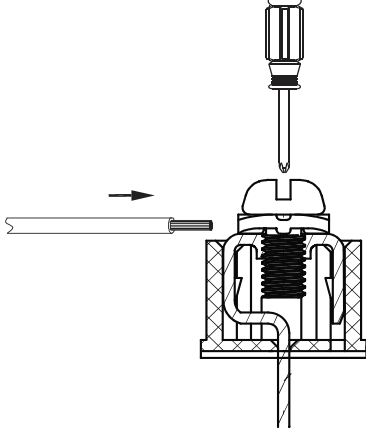

Fig. 9 — Connecting Communication Wire to Outdoor Unit Communication Terminal

If communication wires are used to connect between indoor units, then find the corresponding port and plug it directly as shown in Fig. 10.

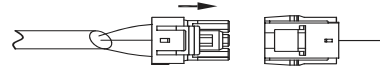

Fig. 10 — Connecting the Communication Wires

If for any reason it is not possible to buy communication wires from Carrier, connect the indoor unit side of the communication wires using the connector provided with the accessories as shown in Fig. 11-13.

⚠ CAUTION

Failure to follow these procedures may result in personal injury or damage to equipment.

NEVER CONNECT the main power source to the control or communication terminal block.

USE AN APPROPRIATE SCREWDRIVER for tightening the terminal screws. Do not over tighten the terminal screws.

IMPORTANT: Wiring for communication shall be 2 in. or more apart from power source wiring to avoid electric noise. (Do not insert control/communication and power source wire in the same conduit.)

Pay attention to the polarity of the communication wire.

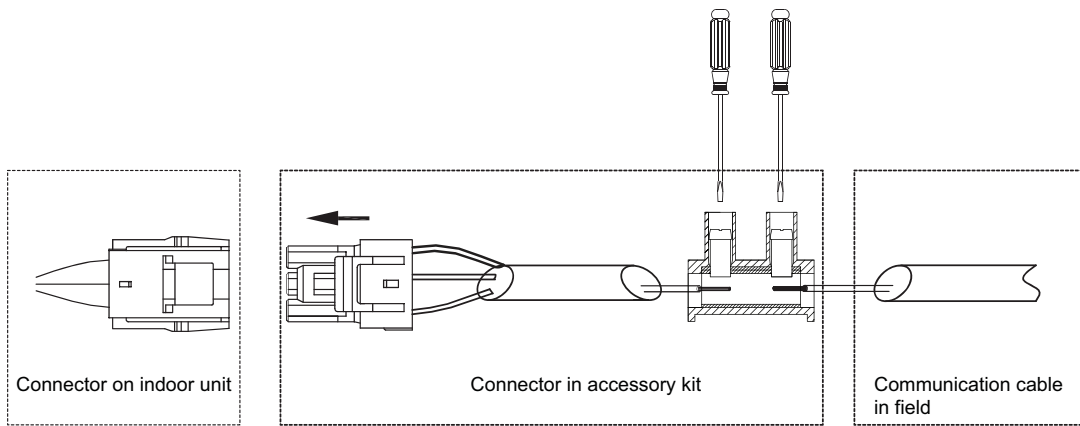

Fig. 11 — Connecting the Communication Cable to Indoor Unit to Outdoor Unit Using the Supplied Connector

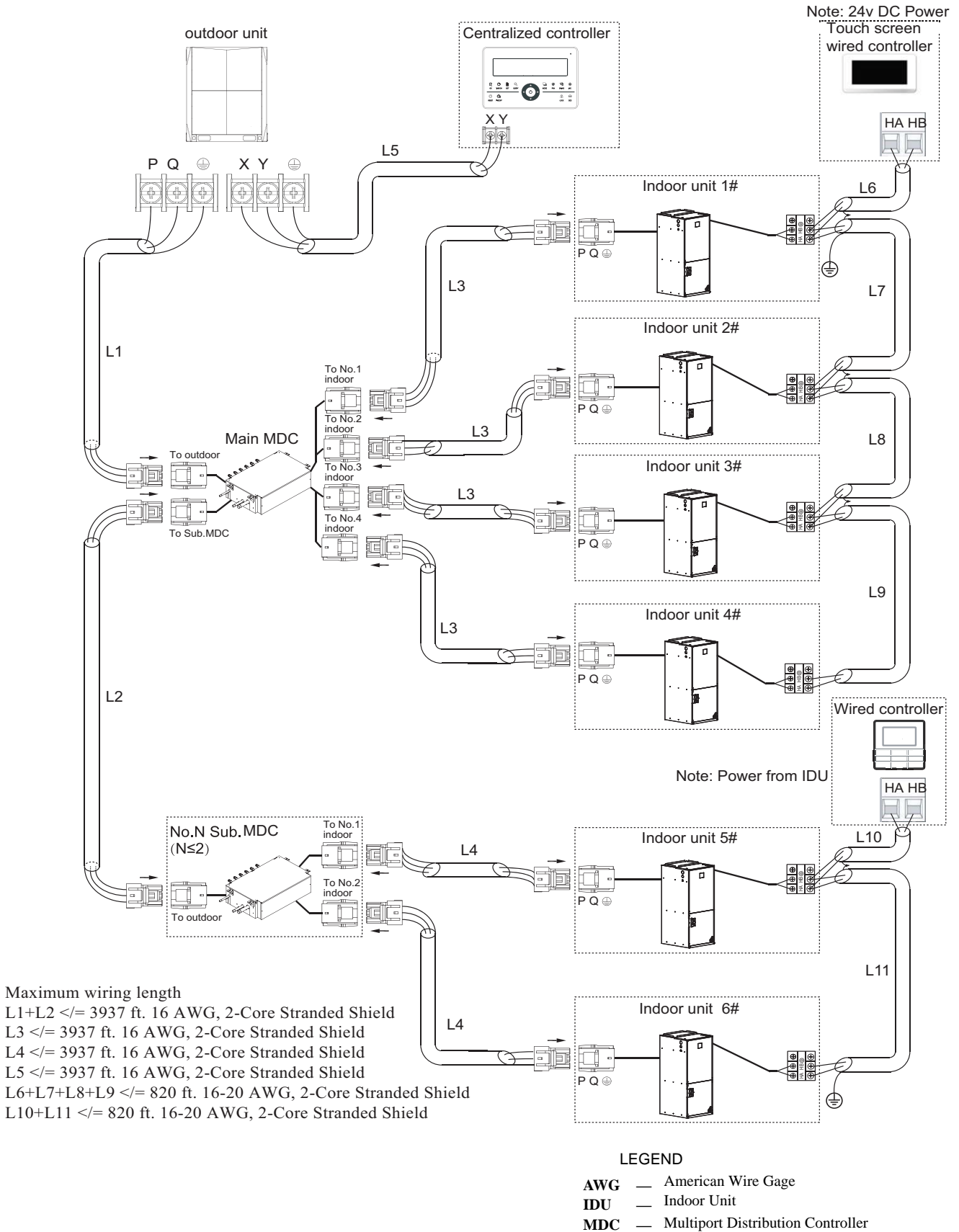

Fig. 12 — Typical Communication Wiring of Heat Recovery System

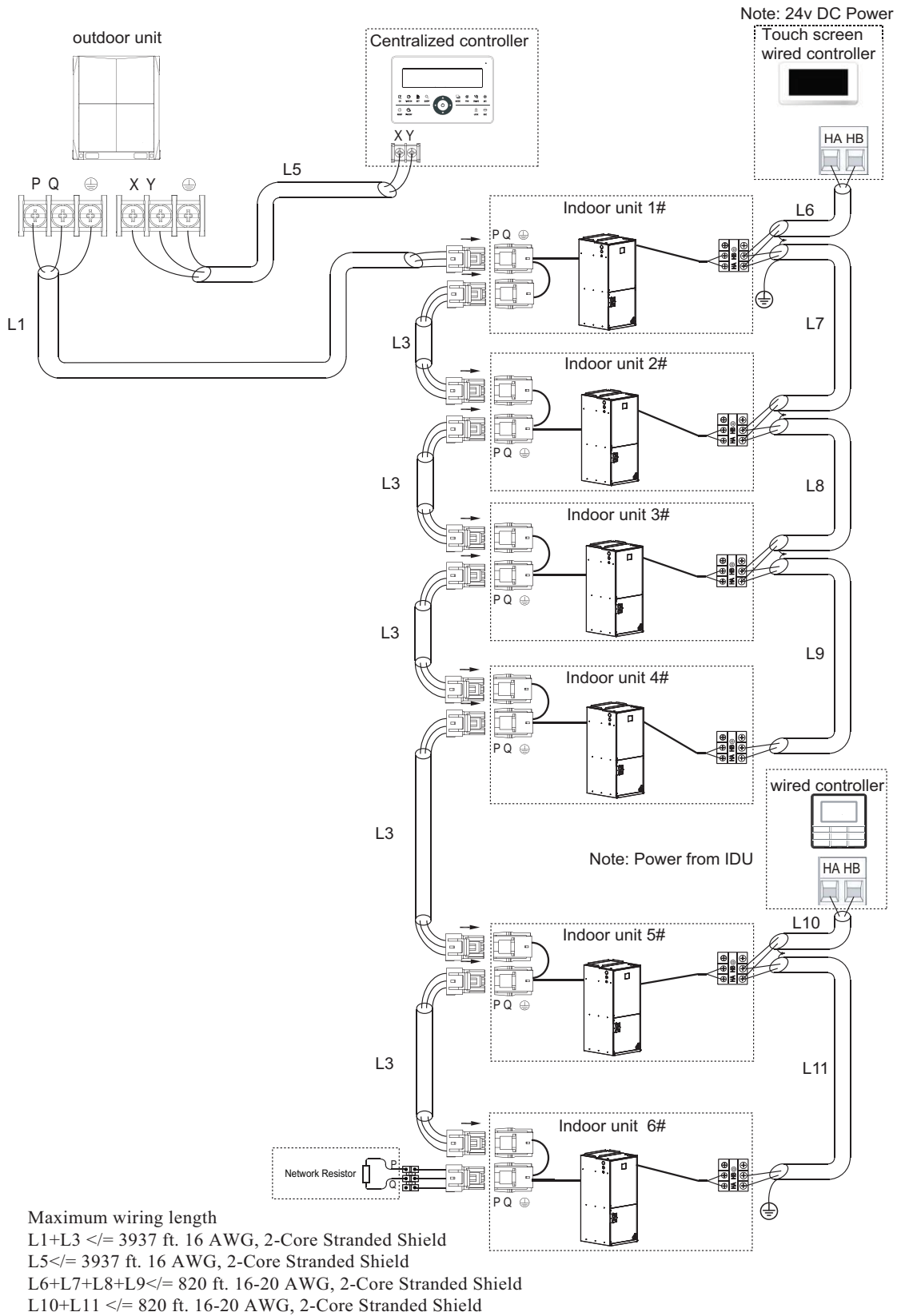
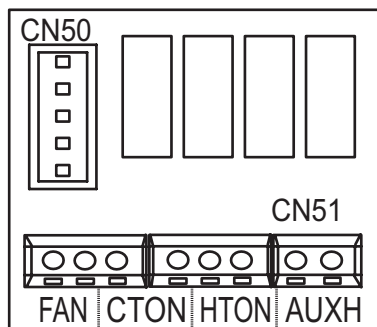

Fig. 13 — Typical Communication Wiring of Heat Pump System

ACB (Auxiliary Control Board) Interface The ACB interface is a dry contact board, it can output up to four signals controlling devices. Please refer to Fig. 14 for connecting devices to the ACB interface board.



MAX AMPS	1A
MAX VOLTAGE	24V

LEGEND

- ACB** — Auxiliary control board
- AUXH** — Output for auxiliary heat
- CTON** — Output for cooling operation
- FAN** — Output for exhaust fan
- HTON** — Output for heating operation

Fig. 14 — ACB Interface

START-UP

Pre-Start Check Once installation is complete, make the following pre-start checks:

1. All indoor and outdoor units are properly installed.
2. All piping and insulation is complete.
3. All electrical connections (both power and control) are properly terminated.
4. All condensate drains are installed correctly.
5. The power supply is of the right voltage and frequency.
6. The units are properly grounded in accordance with current electrical codes.
7. Suction and liquid line service valves are in open position.

System Operation Check Once the installation and pre-start checks are completed, follow these steps:

1. Using remote controller, select cooling or heating mode to check the operation of the system.
2. While the system is in operation, check the following on indoor unit:
 - a. Switches or buttons on the remote controller are easy to push.
 - b. Indicator light is showing normal operation and no error is indicated.
 - c. Swing mode of air louvers is working (if applicable to unit).
 - d. Drain pump operation is normal (if applicable).
 - e. No abnormal vibration or noise is noticed.

3. While the system is in operation, check the following on outdoor unit:
 - a. No abnormal vibration or noise is noticed.
 - b. Condenser fan is in operation.
 - c. Indicator light is showing normal operation and no error is indicated.

NOTE: If the unit is turned off or restarted, there is a time delay of 3 minutes for the compressor to start from the time the power is restored.

MAINTENANCE

⚠ CAUTION

When servicing or repairing this unit, use only factory-approved service replacement parts. Refer to the rating plate on the unit for complete unit model number, serial number and company address. Any substitution of parts or controls not approved by the factory will be at the owner's risk and may result in equipment damage.

⚠ CAUTION

To avoid equipment damage, do not attempt to reuse any mechanical or electrical controllers that have been wet. Replace defective controller.

Every 3 Months:

- Check the air filter condition. Clean or replace if necessary.

Every 6 Months:

- Follow 3-month maintenance schedule. In addition:
- Clean condensate tray with suitable cleaning agent.
 - Clean the grille and panel.

Every 12 Months:

- Follow 6-month maintenance schedule. In addition:
- Be sure all electrical connections are secure.
 - Check condensate pump operation.
 - Check the heating and cooling action to confirm proper operation.

INDOOR UNIT ADDRESSING

For proper system operation each indoor unit must have a unique address set from 0 to 63. When setting an address by remote controller the outdoor units, indoor units, and MDC must be powered on. If "FE" is displayed on the LED screen or display board this unit has no address. After setting all indoor units' addresses, turn off the power supply to all indoor units to clear errors.

Indoor units' addressing can be distributed automatically in the heat pump system. When dip switch "S6" on the outdoor units main PCB board is set to 00 (default set in factory) indoor unit's are set for auto-addressing. When powering on for the first time it takes 6 minutes or more to finish auto-addressing each indoor unit. The heat recovery system cannot accomplish this function at this time.

Wireless Remote Controller (40VM900001) (included with the outdoor unit)

Indoor unit addressing can be performed using the wireless remote controller. When using the wireless controller, the user must maintain a line of sight with the receiver on the indoor unit. See Fig. 15 for a description of the buttons on the wireless remote.

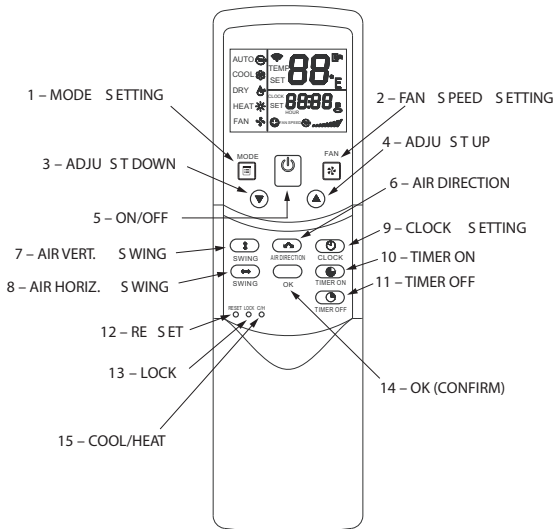

Fig. 15 — Wireless Remote Controller (40VM900001)

Click **TEMP. UP** or **TEMP. DOWN** to change 00 to the desired address as shown in Fig. 17. Then press **OK** to confirm and exit the setting interface.

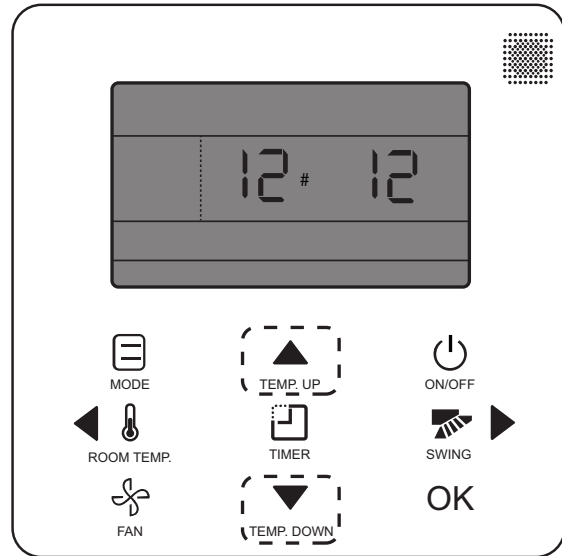

Fig. 17 — Non-Programmable Controller (40VM900002) Setting IDU Address

Use a tool to press and hold the **LOCK** button for at least 10 seconds, then press **MODE** to activate. Click **TEMP. UP** or **TEMP. DOWN** to select an address and press **OK** to send the setting.

To display an indoor unit address, use a tool to press and hold the **LOCK** button for at least 10 seconds, and press **MODE** to query the addresses.

Non-Programmable Controller (40VM900002)

When setting an address, connect only one wired controller to an indoor unit.

Press **ROOM TEMP** and **SWING** simultaneously for 3 seconds. If there is no address for this indoor unit, the display shows **FE# 00** (see Fig. 16) otherwise the display shows the current address of the indoor unit.

Programmable Controller (40VM900003)

When setting an address, connect only one wired controller to an indoor unit.

1. access parameter settings as shown in Fig. 18.

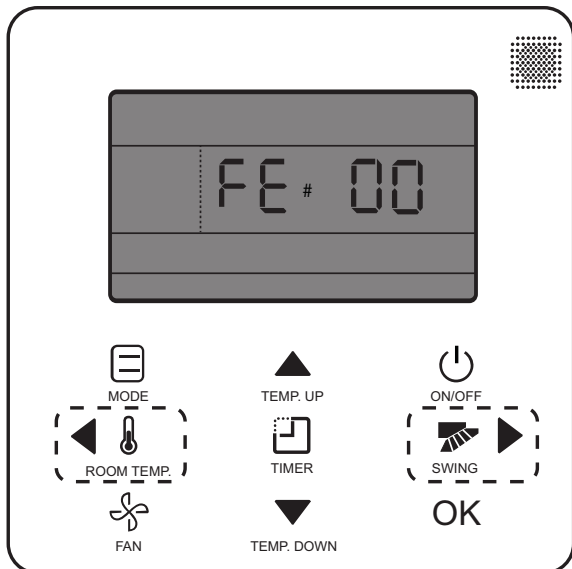

Fig. 16 — Non-Programmable Controller (40VM900002) IDU Addressing Menu

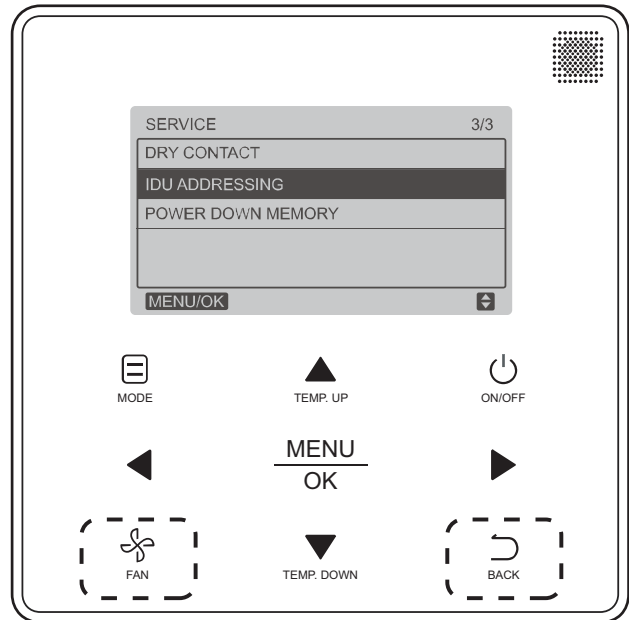

Fig. 18 — Programmable Controller (40VM900003) IDU Addressing Menu

2. Press **TEMP. UP** or **TEMP. DOWN** to move the cursor down and choose **IDU ADDRESSING**, then **MENU/OK** to access this setting.

3. Press **TEMP. UP** or **TEMP. DOWN** to choose the address you want to set, see Fig. 19. Press **MENU/OK** to send this address to the IDU.

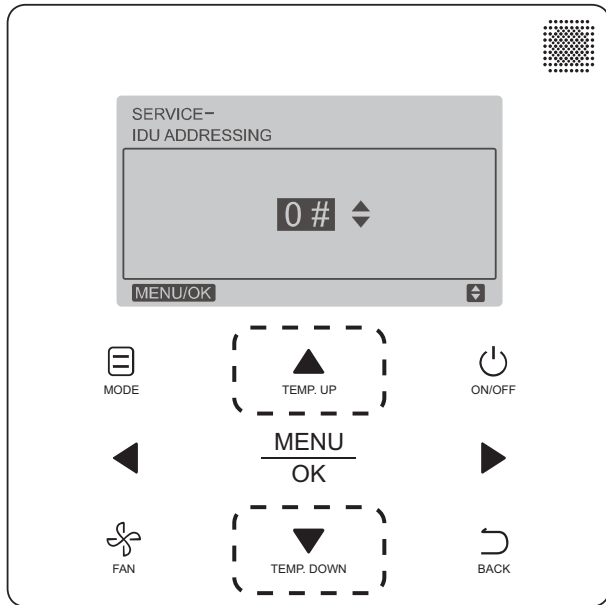

Fig. 19 — Programmable Controller (40VM900003) Setting IDU Address

4. Press **BACK** twice or wait 30 sec. to automatically exit the parameter settings menu.

TROUBLESHOOTING

Figure 20 shows the LED display panel. See Table 5 for a summary of display indicators. Table 6 lists problems, possible causes, and possible solutions.

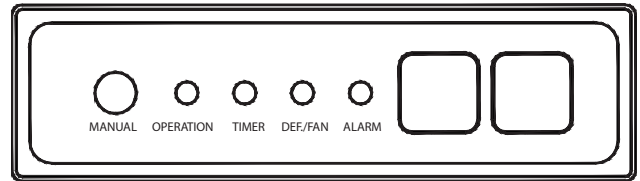

Fig. 20 — Display Panel

Table 5 — Display Indicators

ERROR CODE		MODE / STATUS
[NO ERROR]	Setting Temperature	Starting
	"_ _"	Shutdown
	"_ _"	Standby
	"_ _"	Timing ON
	"_ _"	Timing OFF
	Setting Temperature	System Defrost ON
Setting Temperature	System Defrost OFF	
ERROR	dd	Heating / Cooling Mode Conflict Error
	E1	Communication Error Between Indoor and Outdoor Unit
	E2	Check Indoor Ambient Temperature Sensor (T1)
	E4	Check Evaporator Temperature Sensor (T2)
	E5	Check Evaporator Outlet Temperature Sensor (T2B)
	E6	Check DC Fan Motor
	E7	EEPROM Error (Data Storage)
	E9	Communication Error Between Indoor Unit & Controller
	Eb	EEV Error
	Ed	Outdoor Unit Error
	EE	Condensate Error
	FE	No Address When Power ON For First Time
UU	MDC Error In Auto System-Check Mode	

LEGEND

EEPROM	— Electronically Erasable Programmable Read-only Memory
EEV	— Electronic Expansion Valve
MDC	— Multiport Distribution Controller

Table 6 — Troubleshooting

ERROR	DESCRIPTION	POSSIBLE CAUSES	POSSIBLE SOLUTIONS
dd	Heating / Cooling Mode Conflict	System is in cooling or fan only mode and heating signal is received from a unit on the system.	All units should be in cooling mode for system to stay in cooling mode.
		System is in heating mode and cooling signal is received from a unit in the system.	All units should be in heating mode.
E1	Communication Error Between Indoor & Outdoor Unit	Signal wires are short-circuited or disconnected.	Check or reconnect signal wire.
		Signal wire close to electromagnetic source.	Distance signal wires from electromagnetic source.
		PC board fault.	Replace PC board.
E2, E4, E5	Check Temperature Sensor	Loose connection at port on PC board.	Tighten the connection at port on PC board.
		Sensor is short-circuited.	Using multi-meter, measure resistance of the sensor. If the resistance is £ 100 ohms, change the sensor.
		PC board fault.	Replace PC board.
E6	DC Fan Motor	Operating Beyond Limits.	Check and correct external static pressure on the unit.
		DC motor fault.	Replace DC motor.
		PC board fault.	Replace PC board.
E7	EEPROM Error (Data Storage)	Chip or PC board fault.	Replace PC board.
E9	Communication Error Between Indoor Unit & Controller	Signal wires are short-circuited or disconnected.	Check or reconnect signal wires.
		Signal wires close to electromagnetic source.	Distance signal wires from electromagnetic source.
		PC board fault.	Replace PC board.
Eb	EEV Error	EEV wires are short-circuited or disconnected.	Replace EEV wires.
		EEV stop.	Replace EEV.
		PC Board fault.	Replace PC board.
Ed	Outdoor Unit Error	Outdoor unit fault.	Refer to outdoor unit troubleshooting guide.
EE	Condensate Error	Loose connection or disconnected.	Tighten the connection or reconnect at port on PC board.
		Water level float is stuck.	Inspect the slope.
		Trap slope is too steep.	Adjust the trap slope.
		Drain pipe is too long.	Adjust the length of drain pipe.
FE	No Address When Power ON for first time	Indoor unit without address.	Run automatic addressing option at the outdoor unit.
			Use remote wireless or wired controller to readdress indoor unit.
UU	MDC Auto System-Check Mode	MDC fault	Refer to MDC troubleshooting guide.

- LEGEND**
- EEPROM** — Electronically Erasable Programmable Read-only Memory
 - EEV** — Electronic Expansion Valve
 - MDC** — Multipoint Distribution Controller
 - PC** — Process Controller

Replacement Parts Quote the unit model number and unit serial number when ordering replacement parts or contacting the factory about the unit. This information can be found on the serial plate attached to the unit. See Fig. 21.



CONFORMS TO UL STD 1995 CERTIFIED TO CSA STD. C22.2 No. 236						
ELECTRIC CHARACTERISTICS ARE ONLY FOR INDOOR UNIT.						
Vertical Air Handler						
MODEL	40VMV018---3					
POWER SUPPLY	208/230V-1Ph-60Hz					
MINIMUM CIRCUIT AMPACITY	3.8 A					
MAX FUSE OR HACR BREAKER	15 A					
MAX EXTERNAL STATIC PRESSURE	0.8 IN.W.C.					
FAN MOTOR	FLA	3.0 A				
	OUTPUT	370W (1/2HP)				
REFRIGERANT	R410A					
DESIGN PRESSURE	HIGH	580 PSIG				
	LOW	320 PSIG				
Installed	Heater Kit Model	Electric Heat (KW)	Min. Circuit Ampacity (HACR) Ampacity			
		240	208	240	208	
<input type="checkbox"/>	40WAS10005	5	29.8	26.8	30	30
SERIAL NO.						
		1716V00001				
Carrier Corporation						

Fig. 21 — Unit Serial Plate (Example)

APPENDIX A —DIP SWITCH SETTINGS

There are 2 DIP switches on the main board. Figures A and B show the settings for each parameter controlled by a switch. Switches are shown in the default settings.



POSITION 1 — START-UP

- OFF** — Auto Addressing Mode (Default)
- ON** — Factory Test Mode



POSITION 2 —

- OFF** — Normal Mode (Default)
- ON** — Factory Self-Checking Mode



POSITION 3 — NOT USED

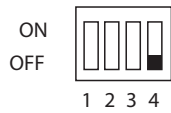

POSITION 4 — INDOOR UNIT IDENTIFICATION

- OFF** — Standard Indoor Unit (Default)
- ON** — Mode Priority Indoor Unit (HP only)
(IDU address must be 63)

Fig. A — SW1 Settings



POSITION 1, 2 — NOT USED

Fig. B — SW8 Settings

APPENDIX B — FAN CURVES

The Vertical Air Handling Unit is equipped with a constant cfm motor which automatically adjusts the fan speed if the actual cfm is beyond +/- 10% of the setpoint cfm.

Figures A-G show fan characteristics at high-speed, medium-speed, and low-speed.

External static pressure on the vertical air handling unit cannot exceed 0.8 in. wg.

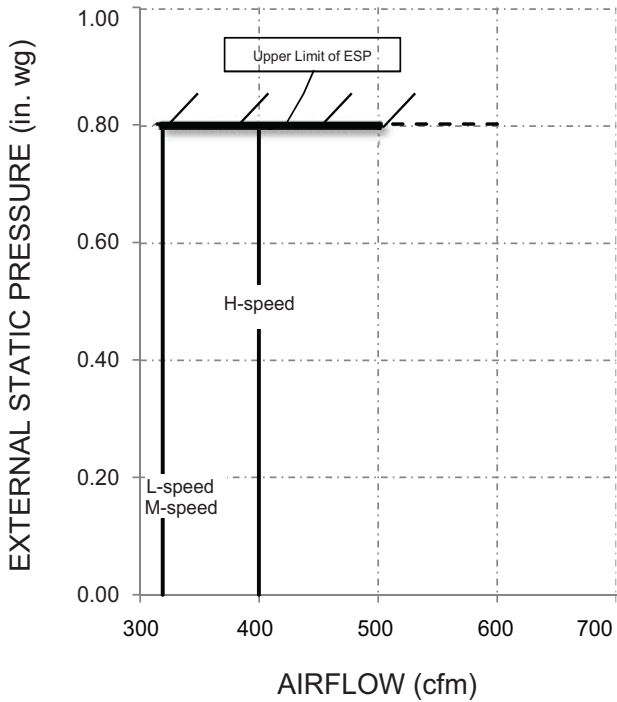

Fig. A — 40VMV012 Fan Curves

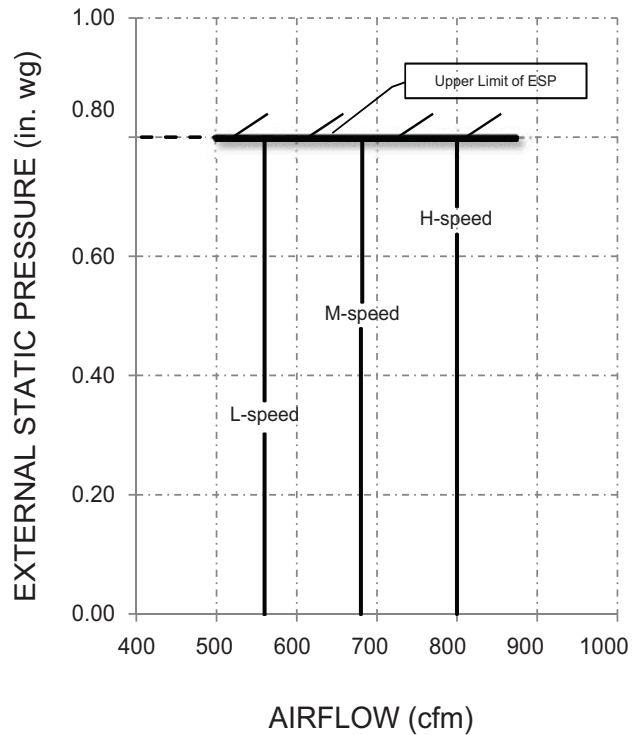

Fig. C — 40VMV024 Fan Curves

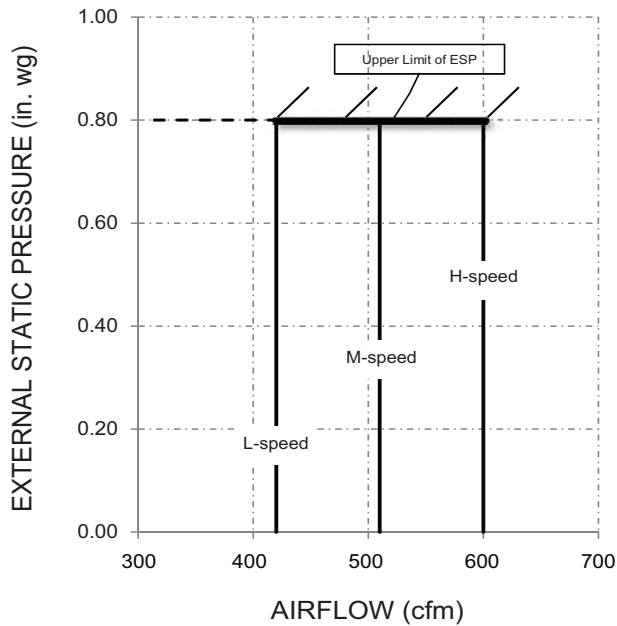

Fig. B — 40VMV018 Fan Curves

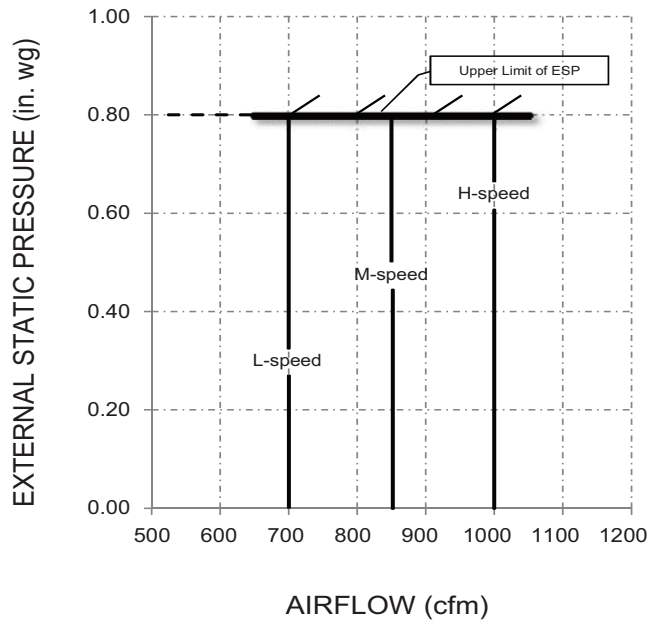

Fig. D — 40VMV030 Fan Curves

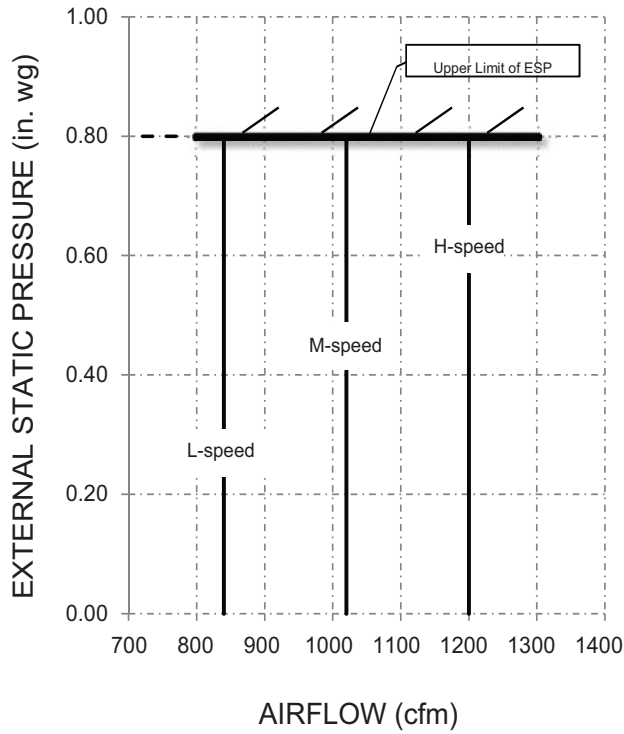

Fig. E — 40VMV036 Fan Curves

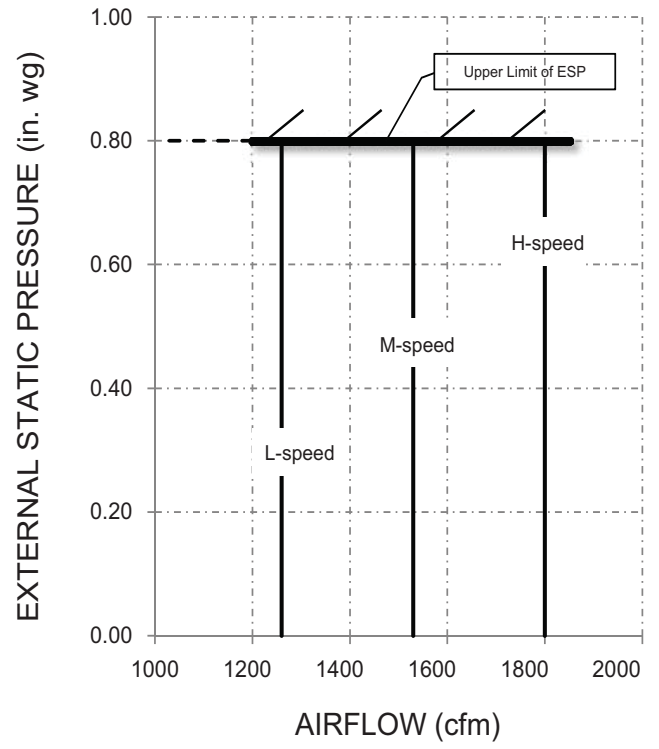

Fig. G — 40VMV054 Fan Curves

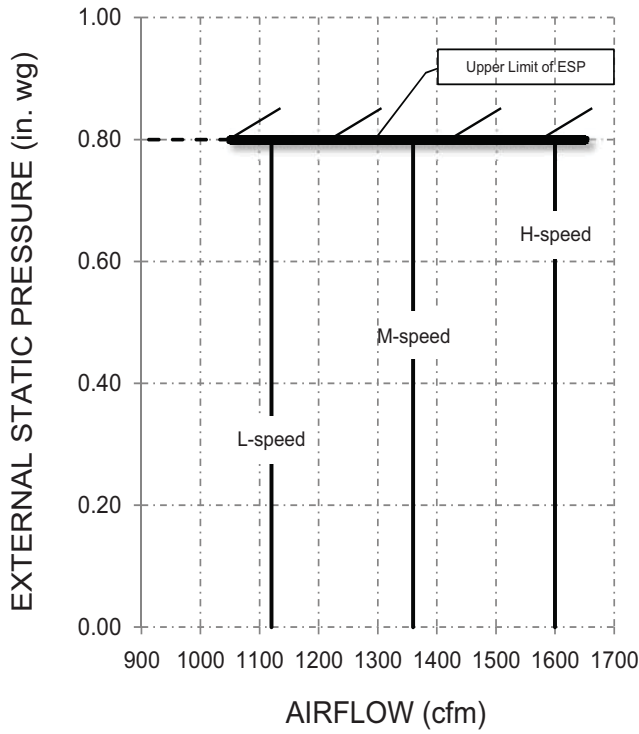

Fig. F — 40VMV048 Fan Curves

