

**40WAC,WAF,WAW,WAD,  
WAH,WAU,WAV**

**Single-Phase VRF (Variable Refrigerant Flow) System  
Central Controller Accessory**

# Installation and Operating Instructions

Part Number 40WA900024

## CONTENTS

	Page
<b>SAFETY CONSIDERATIONS</b> .....	1
<b>GENERAL</b> .....	1
<b>INSTALLATION</b> .....	1-3
<b>Controller Installation</b> .....	1
<b>System Wiring</b> .....	3
<b>OPERATION</b> .....	4-7
<b>Red Status Indicator</b> .....	5
<b>Backlight</b> .....	5
<b>Power On or Reset Signal</b> .....	5
<b>Indoor Unit Address Display</b> .....	5
<b>Individual Unit Operation</b> .....	6
<b>Global Operation</b> .....	6
<b>Control Summary</b> .....	6
<b>Filter Cleaning</b> .....	7
<b>TROUBLESHOOTING</b> .....	7,8

## SAFETY CONSIDERATIONS

Read and follow manufacturer instructions carefully. Follow all local electrical codes during installation. All wiring must conform to local and national electrical codes. Improper wiring or installation may damage thermostat.

Understand the signal words — DANGER, WARNING, and CAUTION. DANGER identifies the most serious hazards which will result in severe personal injury or death. WARNING signifies hazards that could result in personal injury or death. CAUTION is used to identify unsafe practices, which would result in minor personal injury or product and property damage.

Recognize safety information. This is the safety-alert symbol (⚠). When this symbol is displayed on the unit and in instructions or manuals, be alert to the potential for personal injury. Installing, starting up, and servicing equipment can be hazardous due to system pressure, electrical components, and equipment location.

## GENERAL

The single-phase VRF (variable refrigerant flow) central controller is a wall-mounted, low-voltage supply (24 vac) thermostat that can control 64 indoor units. The controller does not require batteries.

The central controller accessory is available for use with the single-phase VRF (variable refrigerant flow) indoor units listed in Table 1.

**Table 1 — Central Controller Accessory Usage**

UNIT	SIZES
<b>40WAC Compact Cassette</b>	007,009,012,015
<b>40WAF 4-Way Cassette</b>	009,012,015,018,024,030,048
<b>40WAW High Wall</b>	007,009,012,015,018
<b>40WAD Ducted</b>	007,009,012,015,018,024
<b>40WAH High Static</b>	024,030,036,048
<b>40WAU Under Ceiling</b>	012,015,018,024,030,036,048
<b>40WAV Vertical</b>	018,024,030,036,048

## INSTALLATION

**Controller Installation** — The controller should be mounted:

- approximately 48 in. from the floor
- on a section of wall without water or drainage pipes
- typically in a mechanical room, facility manager’s office, or central control room

To install the controller, perform the following procedures:

1. Turn off all power to the system (outdoor and all indoor units).

**⚠ WARNING**

Electrical shock can cause personal injury and death. Before installing thermostat, shut off all power to this equipment during installation. There may be more than one power disconnect. Tag all disconnect locations to alert others not to restore power until work is completed.

**⚠ CAUTION**

Failure to follow this caution may result in equipment damage or improper operation. Improper wiring or installation may damage the thermostat. Check to make sure wiring is correct at the controller and unit ends before proceeding with installation or turning on unit.

2. Confirm that 24 vac power supply is available to power the controller at this location.
3. Be sure that total signal wire length from the central control does not exceed 3,937 feet.
4. Shielded 3-core control cable is required with no intermediate joints. If a joint is necessary, make the connection using a terminal block in an acceptable enclosure. All three conductors and the shield must be connected at the terminal block.

5. Connect one end of the shielded 3-core control cable to the control wiring terminal block on the outdoor unit. See Fig. 1.

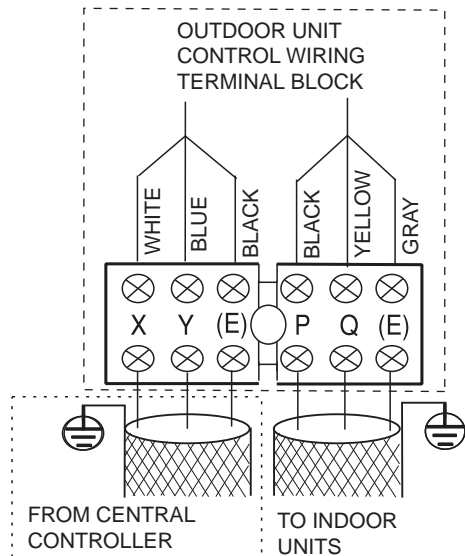

**Fig. 1 — Control Wiring Terminal Block**

6. For wall-hung or under-ceiling/floor units, provide a 1-in. by 1-in. square opening in the surface behind the unit to route the shielded 3-core control cable, furred in to connect the indoor unit display panel to the controller.  
For concealed ducted, high static ducted, cassette, or vertical units, the shielded 3-core cable can be routed through the plenum and the wall to connect the indoor unit display panel and the controller.
7. Insert a flat-head screwdriver into the slots provided on the top of the controller to open the back mounting plate. See Fig. 2.

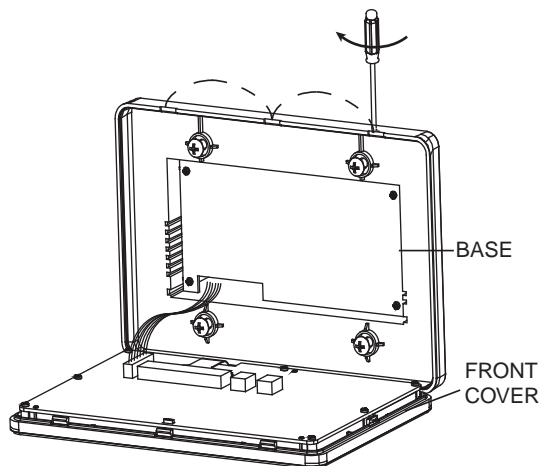

**Fig. 2 — Opening Back Mounting Plate**

8. Attach the back mounting plate directly over the opening in the wall, using 4 screws, and route the control cable as shown in Fig. 3.

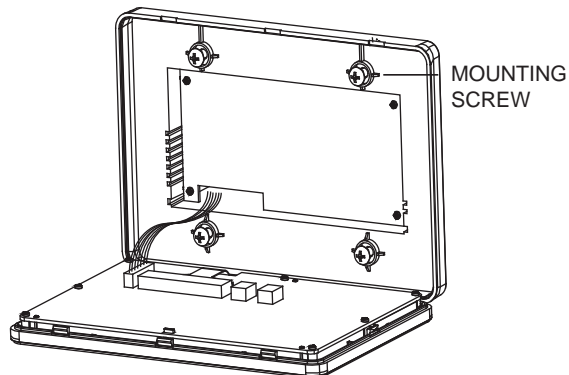

**Fig. 3 — Attaching Back Mounting Plate**

9. Connect the control cable and power to the back of the controller and mount the controller back onto the mounting plate. See Fig. 4.

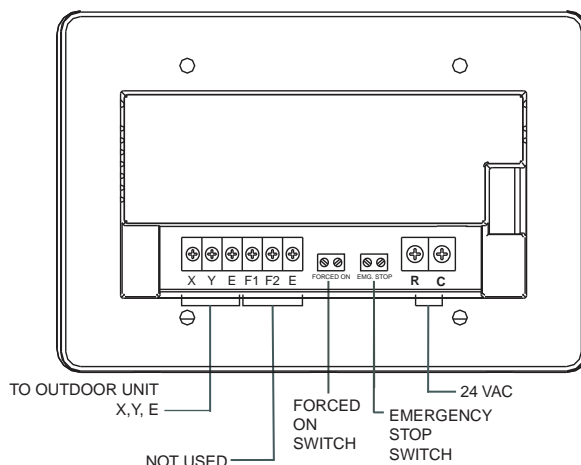

**Fig. 4 — Central Controller Wiring**

## System Wiring

- When there are multiple controllers in the system, each controller is assigned a unique address code from 0 to 15. Duplicate addresses are NOT allowed.
- After a central controller is connected, DO NOT use an ohmmeter to test signal cable resistance. This should be done before the central controller is connected.
- Control cable is polarity sensitive and MUST NOT be cross-connected. See Fig. 5 for correct connections.
- See Fig. 6 for complete system central controller wiring diagram.

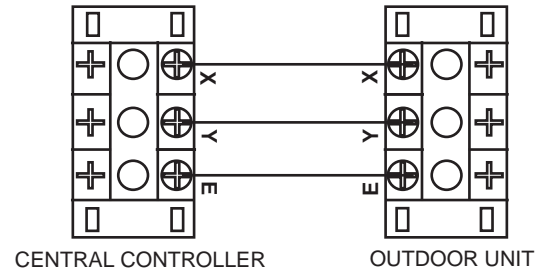

**Fig. 5 — Controller Connections**

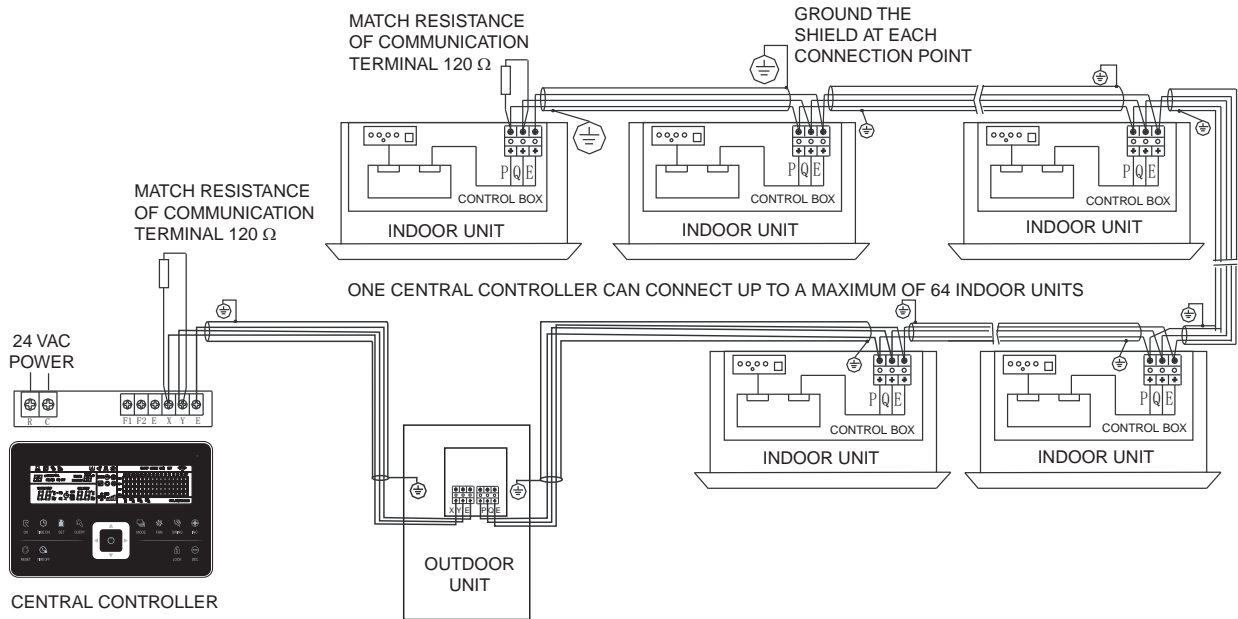

**Fig. 6 — Central Controller System Wiring**

## OPERATION

Figure 7 shows the central controller LCD display and button controls. Refer to this figure in the operation sections that follow.

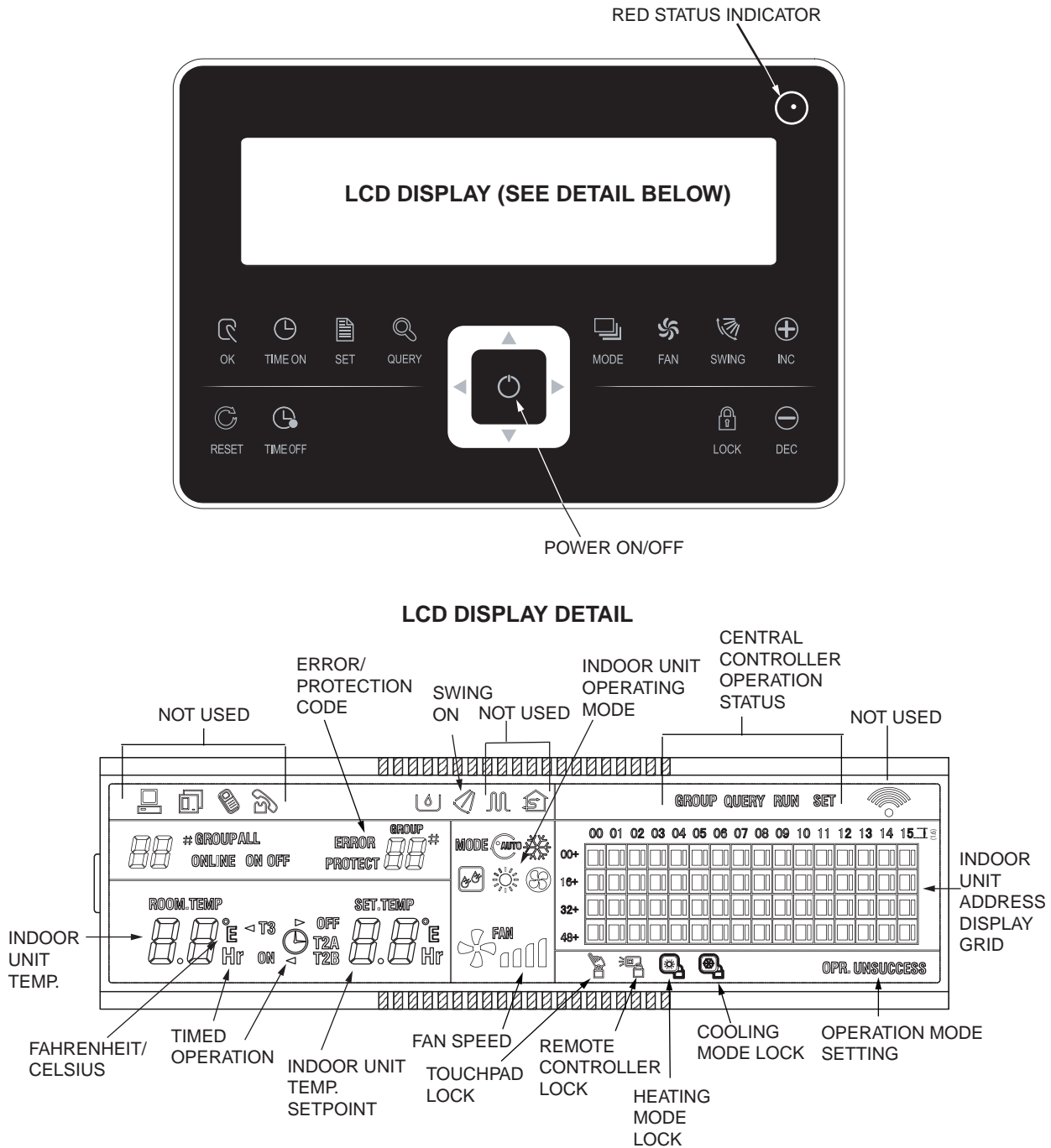

**Fig. 7 — Central Controller Display**

**Red Status Indicator** — A steady light indicates that at least one indoor unit is operating, or that the central controller is sending a command to one or more indoor units. A slowly flashing light indicates an indoor unit error or a communication error. When the status indicator is off, no connected indoor unit is operating.

**Backlight** — Press any button except RESET to backlight the display. The backlight remains on while the central controller is being operated. It goes off automatically after 30 seconds of inactivity.

**Power On or Reset Signal** — When the central controller is powered on or reset, the controller beeps for 2 seconds and the display screen lights. The controller then transmits a signal to (queries) the indoor units, and the screen shows the main display. The mode setting screen is then displayed.

**Indoor Unit Address Display** — Indoor unit addresses are displayed in a grid that indicates the status of each unit. The display range is 00 to 63 (64 indoor units maximum). The grid is composed of 64 boxes, each representing one indoor unit. The grid's vertical coordinates are 00+, 16+, 32+, and 48+. The grid's horizontal coordinates are 00 to 15. The sum of the vertical and horizontal coordinates is the address of the indoor unit. (The unit's location on the grid has no relation to the unit's physical location.) For example, the address of the unit with the coordinates 48+,11 is 59. See Fig. 8.

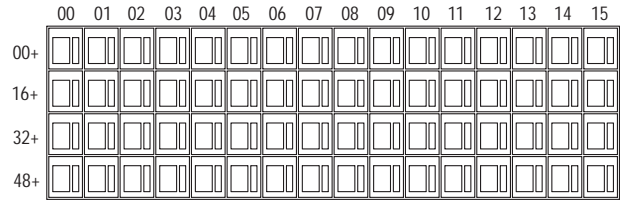

**Fig. 8 — Indoor Unit Address Grid**

Each indoor unit's box in the grid contains 2 display blocks, one large and one small. These signal the unit's status as shown below:

BLOCK	LIGHT SIGNAL			
	STEADILY LIT	SLOW BLINK	FAST BLINK	DIM (NOT LIT)
Large	Connected	Selected	—	Out of service
Small	Power On	—	Error	Power Off

Figure 9 shows an example display on the main display screen. In this example 60 units are in service. Twenty-eight are on, and 32 are off.

- In the grid, the large blocks for the units from 16+,00 to 32+,15 are lit, and the small blocks are dim. This means that the 32 units with addresses from 16 to 47 are connected but powered off.
- Both the large and small blocks for the units from 48+,09 to 48+,12 are not lit. This means that the four indoor units with addresses from 57 to 60 are not connected.
- All the other large and small blocks in the grid are lit. This means that all the other indoor units are connected and powered on.

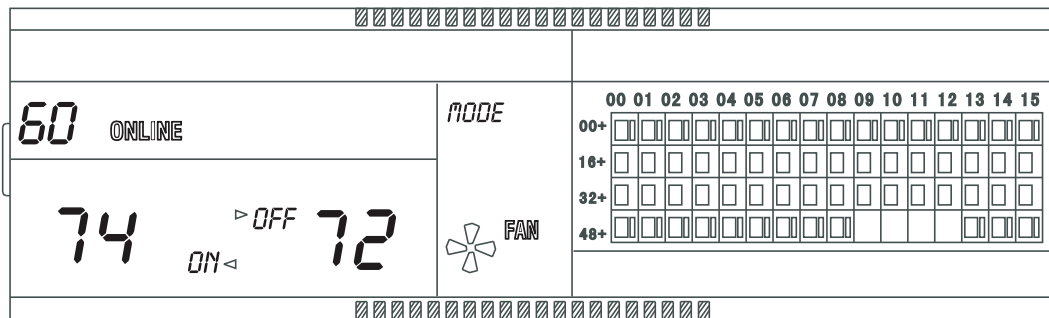

**Fig. 9 — Main Display Screen Example**

## Individual Unit Operation

**POWER A UNIT ON OR OFF** — To power an individual unit on or off, use the arrow buttons to navigate to the unit in the address grid. Press the Power button one short press to turn the unit on (if it is off) or off (if it is on).

### CHANGE SETTINGS FOR A UNIT

1. Use the arrow buttons to navigate to the unit in the address grid.
2. Press SET.
3. Use the MODE, FAN, INC, and DEC buttons to set the operation mode and parameters such as setpoint and fan speed. (See the Control Summary section below for details.)
4. Press OK to transmit all current settings to the selected indoor unit.

## Global Operation

### POWER ALL UNITS OFF OR ON

- Press the Power button one short press to power off all units currently operating.
- If all indoor units are off, press the Power button one short press to power on all units to the currently selected parameters, such as mode, fan speed, and setpoint.
- Press the Power button one long press to send all commands to all indoor units, whether the unit is currently powered on or off. All indoor units currently off will be powered on, and all units will receive the commands.

### CHANGE SETTINGS FOR ALL UNITS

1. Press SET to select all of the indoor units.
2. Use the MODE, FAN, INC, and DEC buttons to set the operation mode and parameters such as setpoint and fan speed. (See the Control Summary section below for details.)
3. Press OK to transmit all current settings to all units.

**Control Summary** — Refer to Fig. 7 for the locations of the buttons described below.

**POWER** — Press to turn the selected indoor units on or off. See the sections Individual Unit Operation and Global Operation above.

**OK** — While in Settings mode (see below), press OK to send all active and updated commands to the selected indoor units.

**SET** — Press the SET button to enter Settings mode and to toggle between an individual unit setting or a global setting for all indoor units. (The default is a single indoor unit.) The settings of the first connected indoor unit are displayed. See Fig. 10 for an example of a Settings mode display screen.

**TIME ON/TIME OFF** — While in Settings mode (see above), press TIME ON to set up the delayed operation start time for the selected indoor units. Press the INC button to select the start hour from 0 to 24 hours. Each button press increments the setting by 1/2 hour for the first 10 hours, then by 1 hour. When the start time is correct, press TIME ON again to set the start time. Press TIME OFF to set the delayed operation stop time, use the INC button to set the time, and press TIME OFF again to set the selected time. Press TIME OFF again to exit timer mode and return to normal operation.

**MODE** — While in Settings mode (see above), press MODE to set the operation mode for a single indoor unit or globally for all connected indoor units. Each MODE press toggles to the next operating mode selection.

**IMPORTANT:** Frequent changes to operating mode may cause the system to malfunction. Allow at least one minute between mode changes to allow the system to stabilize.

**FAN** — While in Settings mode (see above), press FAN to set the fan speed of the selected indoor unit (Auto → Low → Medium → High).

**SWING** — While in Settings mode (see above), press SWING to enable or disable louver settings for the selected indoor units (function not available on all units).

**INC/DEC (TEMPERATURE SETPOINT)** — While in Settings mode (see above), press INC (increase) to increase the temperature setpoint by 1 degree. Press DEC (decrease) to decrease the temperature setpoint by 1 degree.

**QUERY** — Press to display the operation status of a selected indoor unit. The display defaults to the first connected indoor unit. Use the right and left arrow buttons to navigate between indoor units. Press and hold the right or left arrow button to scroll through the connected units in the address grid. Use the INC and DEC buttons to move to the next or previous row of indoor units in the grid. See Fig. 11 for an example of a Query mode display screen.

From the Main screen, pressing the up, down, right, or left arrow button also activates Query mode.

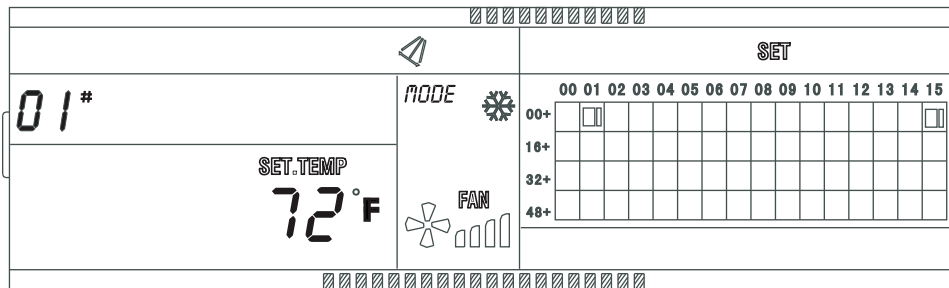

In this example:

1. The indoor unit with the address 01 is selected.
2. The unit is in Cooling mode, the fan speed is High, Swing mode is on, and the set point is 72 F.
3. In the address grid, only the large and small blocks at addresses 00+,01 and 00+,15 are lit. This means only the indoor units with the addresses of 01 and 15 are connected and powered on.

**Fig. 10 — Settings Mode Display Screen (Example)**

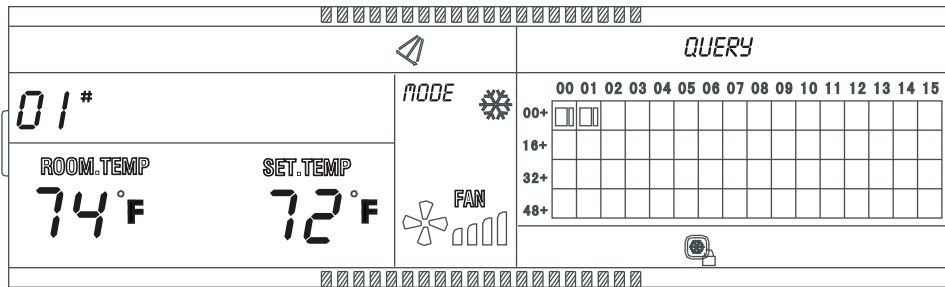

In this example:

1. The indoor unit with the address 01 is being queried.
2. The unit is in Cooling mode, the fan speed is High, Swing mode is on, and the set point is 72 F. The room temperature is 74 F.
3. In the address grid, only the large and small blocks at addresses 00+,00 and 00+,01 are lit. This means only the indoor units with the addresses of 00 and 01 are connected and powered on.

**Fig. 11 — Query Mode Display Screen (Example)**

**LOCK** — In Settings mode, press the LOCK button and the up arrow button at the same time to lock or unlock the operation mode setting for the system. Press and hold the QUERY button and press the LOCK button to lock or unlock the central controller touchpad.

**RESET** — Press and hold the RESET button for 5 seconds to reset the central controller to factory defaults.

**Filter Cleaning** — As set by the factory, error code EC (change/clean filter reminder) is displayed for a unit when 2500 run time hours have elapsed.

A custom reminder and run time can be set instead. When the custom filter reminder is turned on and the specified run time hours have elapsed, the controller displays 88, which is the custom filter reminder function code. After the filter is cleaned, clear the code by pressing and holding the SWING button and pressing the QUERY button at the same time. To set a custom filter cleaning reminder, follow these steps:

1. Set DIP switch 3 on the central controller to ON (default is OFF). See Fig. 12.

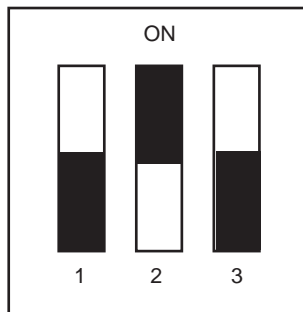

DIP SWITCH	ON	OFF
1	3-Pipe Controller	2-Pipe Controller (Default)
2	Fahrenheit (Default)	Celsius
3	Optional Filter Reminder	No Optional Filter Reminder (Default)

**Fig. 12 — DIP Switch Settings**

2. Power on the controller.
3. Wait 1 minute.
4. Press and hold the QUERY button and press the FAN button at the same time. The controller displays 88 (the display flashes).
5. Use the INC and DEC buttons to set the appropriate function as shown below.

FUNCTION CODE	FUNCTION SETTING
00	Filter reminder off
01	Filter reminder on

6. Press OK.
7. Use the INC and DEC buttons to select the code for the number of run time hours as shown below.

PARAMETER CODE	TIME (HOURS)
00	0
01	1,250
02	2,500
03	5,000
04	10,000

8. Press OK. The controller displays the function code 88 and a “setting successfully” message. After 3 seconds the Main screen is displayed.

## TROUBLESHOOTING

The fault screen is displayed when an error is detected. Fig. 13 shows an example. See Table 2 for a list of error codes.

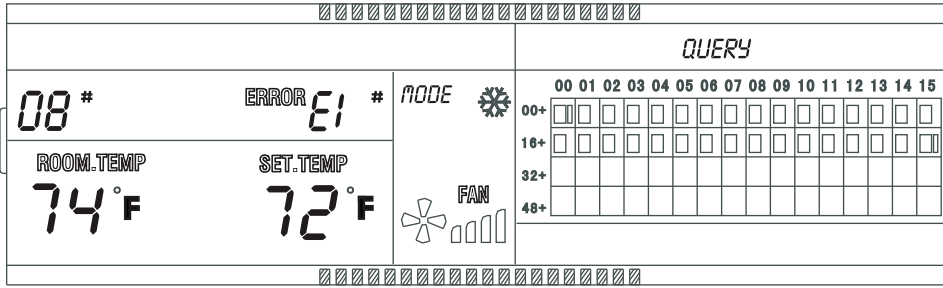

In this example:

1. The indoor unit with the address 08 is being queried.
2. The unit with the address 08 has an error, code E1.
3. In the address grid, the small block at 00+,08 blinks, indicating an error.
4. In the grid, only the indoor units at addresses 00+,00 and 16+,15 are lit. This means only that only the indoor units with the addresses of 00 and 31 are powered on.

**Fig. 13 — Error Display Screen (Example)**

**Table 2 — Error Codes**

ERROR CODE	DESCRIPTION	POSSIBLE CAUSES	POSSIBLE SOLUTIONS
E1	Indoor unit and outdoor unit communication failure	Signal wires are short-circuited or disconnected.	Check or reconnect signal wire.
		Signal wire order is incorrect.	Correct signal wire order.
		Signal wires crossing over high voltage power wires.	Separate and distance the signal wire from high voltage power wires.
		Signal wire close to electromagnetic source.	Distance signal wires from electromagnetic source.
		Signal wire length exceeds 360 ft.	Reduce the signal wire length.
		PC board fault.	Replace PC board.
E2	T1 sensor malfunction	Loose connection at port on PC board.	Tighten the connection at port on PC board.
		Sensor is short-circuited.	Using multi-meter, measure resistance of the sensor. If the resistance is $\leq 100$ ohms, change the sensor.
		PC board fault.	Replace PC board.
E3	T2A sensor malfunction	Loose connection at port on PC board.	Tighten the connection at port on PC board.
		Sensor is short-circuited.	Using multi-meter, measure resistance of the sensor. If the resistance is $\leq 100$ ohms, change the sensor.
		PC board fault.	Replace PC board.
E4	T2B sensor malfunction	Loose connection at port on PC board.	Tighten the connection at port on PC board.
		Sensor is short-circuited.	Using multi-meter, measure resistance of the sensor. If the resistance is $\leq 100$ ohms, change the sensor.
		PC board fault.	Replace PC board.
E5	Outdoor unit fault protection	Outdoor unit fault.	Refer to outdoor unit troubleshooting guide.
E7	Indoor unit EEPROM failure	Chip or PC board fault.	Replace PC board.
EC	Change/clean filter reminder	Run time has elapsed.	Clear the code by pressing and holding the SWING button and pressing the QUERY button at the same time.
EE	Water level error	Loose connection or disconnected at port on PC board.	Tighten the connection or reconnect at port on PC board.
		Water level float is stuck.	Inspect the float.
		Trap slope is too steep.	Adjust the trap slope.
		Drain pipe is too long.	Adjust the length of drain pipe.
P0	Evaporator temperature protection	Drain pump faulty.	Replace the drain pump.
		Evaporator coils are covered with dirt and dust	Clean the coils to increase heat transfer rate.
		Incorrect sensor wiring	Correct sensor wiring as per wiring diagram.
		Sensor is short-circuited	Using multi-meter, measure resistance of the sensor. If the resistance is $\leq 100$ ohms, change the sensor.