

Variable Speed Flow Center Quick Start Guide

FCM and FCK Geothermal Flow Centers

The variable speed flow center kit provides a complete piping/factory wiring package, designed to significantly reduce installation time. All components necessary for plumbing and controlling the pump(s) are included. *Please read this quick start guide in its entirety before attempting to install the flow center.*

1. Verify package contents. Included in the package is the panel/flow center/controller, as well as all of the fittings needed for connecting to the ground loop and heat pump (Figures 1a and 1b).

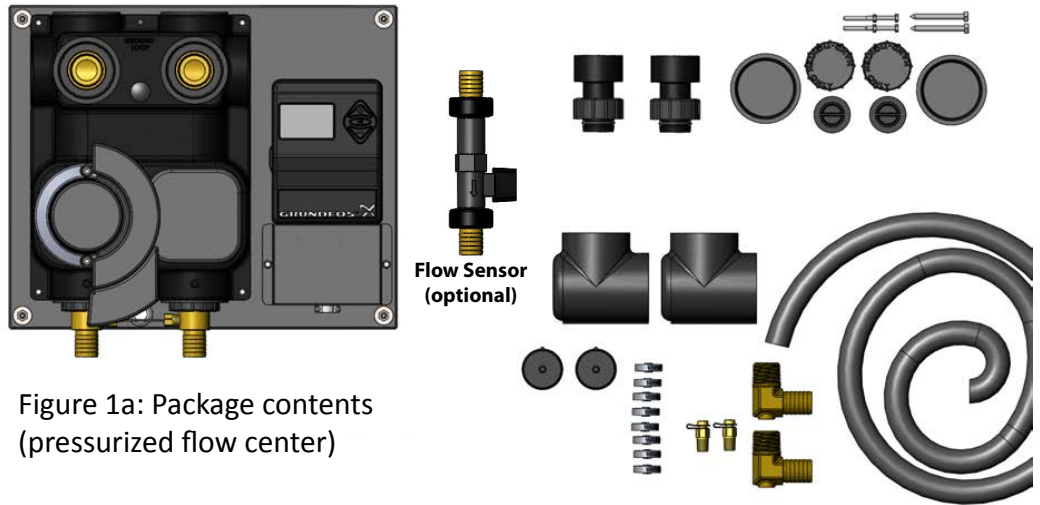

Figure 1a: Package contents (pressurized flow center)

IMPORTANT: Both flow center packages include a wiring kit for non-communicating UPM (Unit Protection Module)/ 24VAC controls. For Carrier and Bryant heat pumps with communicating UPM board, kit part # 4129 (available from Replacement Components) must be added to the kit to utilize all of the available features.

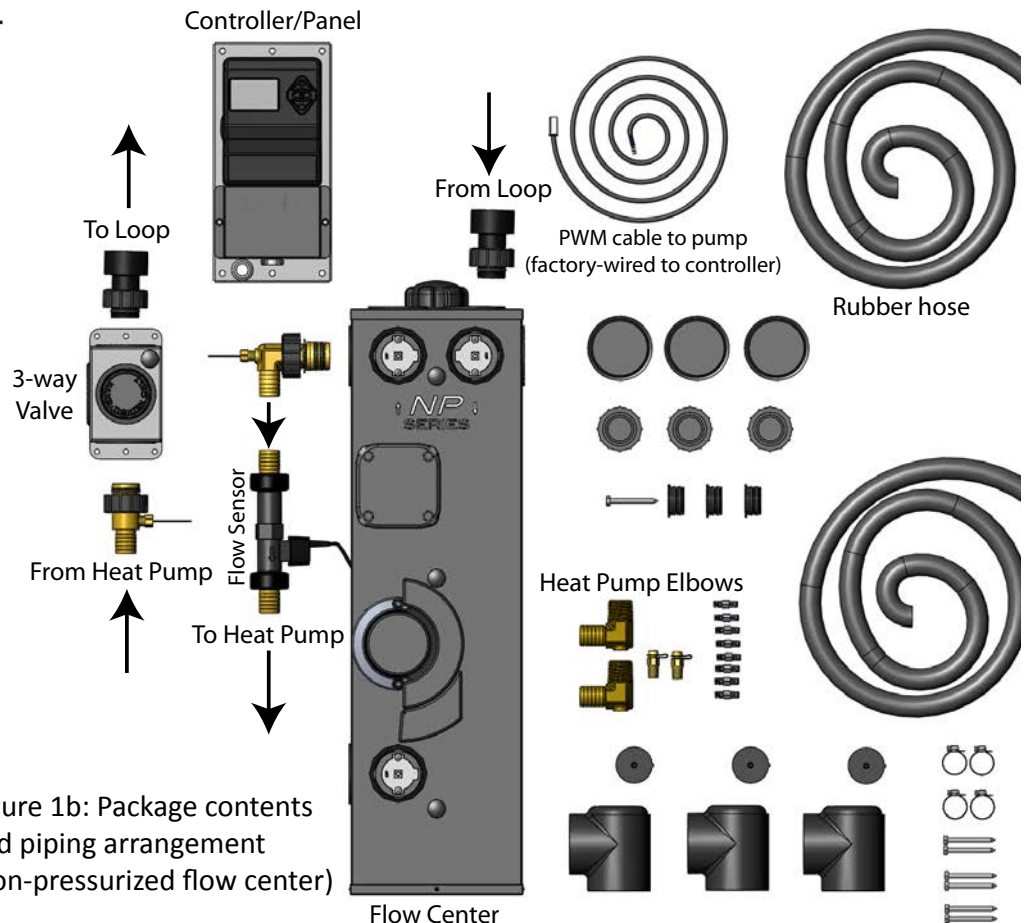

Figure 1b: Package contents and piping arrangement (non-pressurized flow center)

Flow Center

2. Complete ground loop piping. The package includes one set of 1-1/4" PE fusion by Flo-Link double O-ring fittings. Ensure that the fittings are at the correct depth, and not angled. The flow center should be installed as close to the heat pump as possible, so that excessive hose is not needed.
3. Complete heat pump piping. If using a flow sensor (Figure 2, right hand side), cut a small piece of hose (6" to 8") to connect between the barbed connection at the flow center and flow sensor. If the package does not use a flow sensor (temperature difference control only), the small piece of hose is not needed. Then, cut the remaining amount of hose as needed for connections to/from the heat pump and flow center.



WARNING: MAKE SURE THAT HEAT PUMP POWER IS DISCONNECTED BEFORE PROCEEDING TO STEP #4.

4. Connect pump PWM cable and flow sensor. Plug the PWM cable into the pump pigtail (Figure 2). If the flow sensor is included, plug the cable into the flow sensor (cable is pre-wired to controller -- see Figure 2, right hand side).

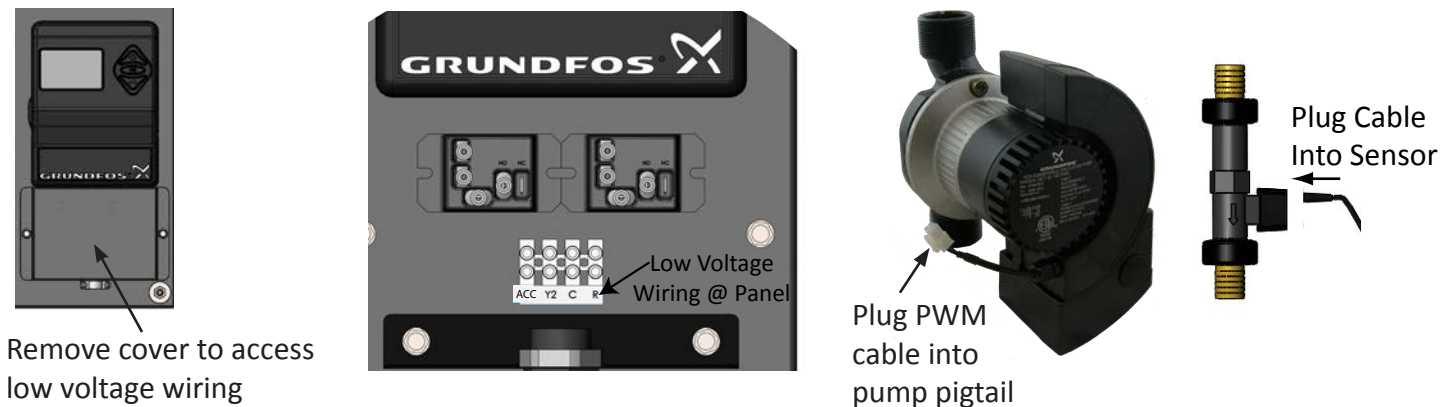

Figure 2: Low Voltage Wiring

5. Wire low voltage connections at flow center. Remove the access cover at the flow center (Figure 2) to access the low voltage connections. Run 4-conductor thermostat wire from the flow center to the heat pump. Connect ACC, Y2, C and R (Y2 needed only for flow centers with flow sensor).
6. Wire heat pump low voltage connections. The heat pump low voltage connections will depend upon the heat pump UPM (Unit Protection Module). Consult Table 1 and Figure 3 for heat pumps with communicating UPM; use Table 2 and Figure 4 for heat pumps with non-communicating UPM.

Heat Pumps with Communicating UPM Board*

Low Voltage Connection at Flow Center Panel (see Figure 2)	Heat Pumps with Communicating UPM Board*
ACC	Yellow wire in P5 extension harness (Figure 3)
Y2	Gray wire in P5 extension harness (Figure 3)
C	Brown wire in P5 extension harness (Figure 3)
R	Red wire with piggyback spade, connected at transformer terminal (Figure 3)

CAUTION: Failure to wire per instructions may cause UPM fuse failures for low voltage circuit

Table 1: Low Voltage Wiring -- Heat Pumps with Communicating UPM Board

*Infinity/Evolution

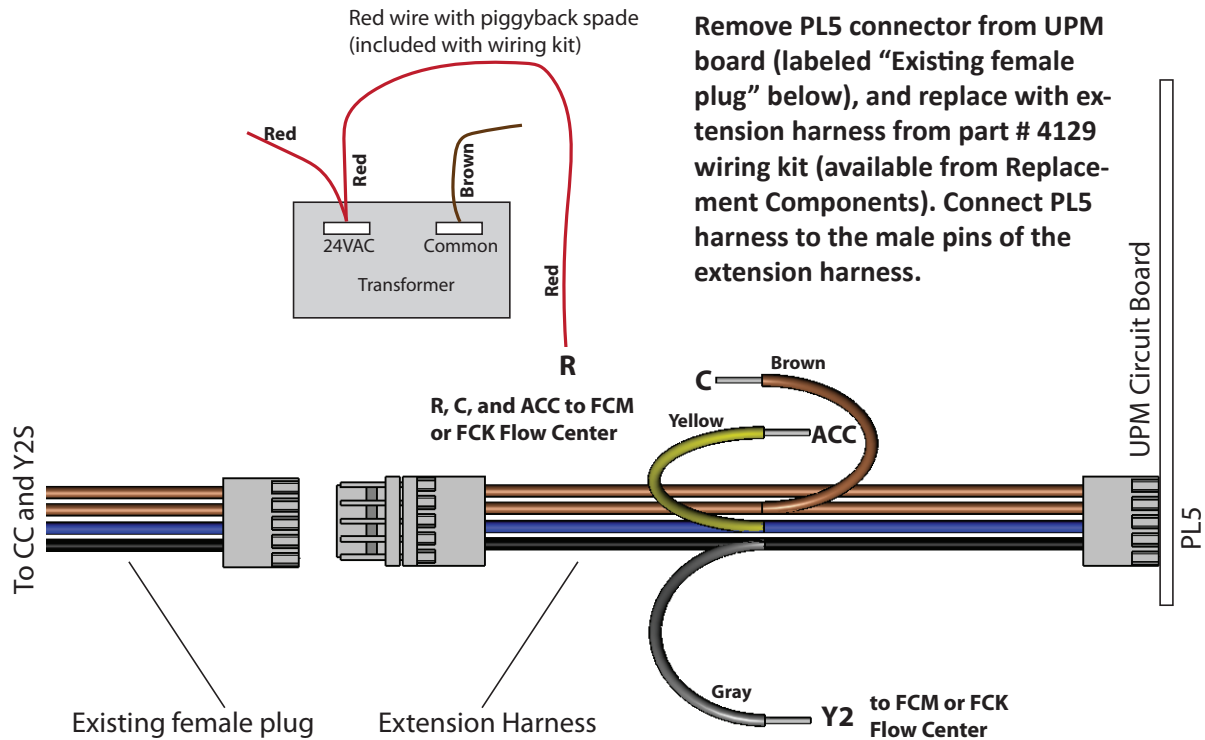
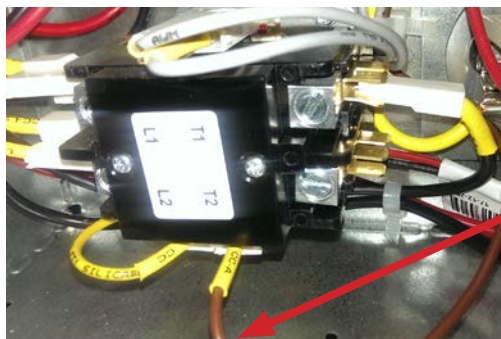

Figure 3: **Communicating UPM Only**
Low Voltage Wiring at Heat Pump

Heat Pumps with Non-Communicating UPM Board (24VAC)

Low Voltage Connection at Flow Center Panel (see Figure 2,)	Heat Pumps with Non-Communicating UPM Board
ACC	Brown wire at compressor contactor coil (Fig. 4)
C	C at thermostat connections (Figure 4)
Y2	Y2 at thermostat connections (Figure 4)
R	R at thermostat connections (Figure 4)

Table 2: Low Voltage Wiring -- Heat Pumps with Non-Communicating UPM board (24VAC Controls / Observer with Daughter Board)



Packaged unit ECM board or Observer daughter board, or split system compressor section air handler connection terminals

ACC connection to flow center: Remove brown wire at compressor contactor coil. Replace with brown wire from wiring kit. Connect other end to ACC at panel.

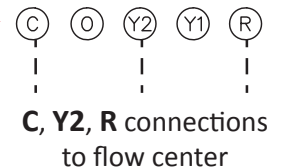

Figure 4: **Non-Communicating UPM Only**
Low Voltage Wiring at Heat Pump



WARNING: MAKE SURE THAT HEAT PUMP POWER IS DISCONNECTED BEFORE PROCEEDING TO STEP #7.

7. Complete high voltage wiring to variable speed pump. Remove pump terminal box cover to access high voltage connections. Run high voltage wiring from the “L” side of the compressor contactor (see CAUTION below) to the variable speed pump terminals (refer to Figure 5). Wiring must meet all applicable code requirements, including requirements for wire protection, such as conduit. Wire size must be at least 14 AWG copper conductor.



CAUTION: DO NOT CONNECT THE VARIABLE SPEED PUMP TO THE “T” SIDE OF THE HEAT PUMP CONTACTOR. THE VARIABLE SPEED PUMP MUST BE POWERED AT ALL TIMES. AFTER VERIFYING THAT THE HEAT PUMP BREAKER AND WIRE SIZE IS SUFFICIENT FOR BOTH THE HEAT PUMP AND THE FLOW CENTER PUMP(S), CONNECT THE VARIABLE SPEED PUMP TO THE “L” SIDE OF THE CONTACTOR.

From “L” side of heat pump contactor

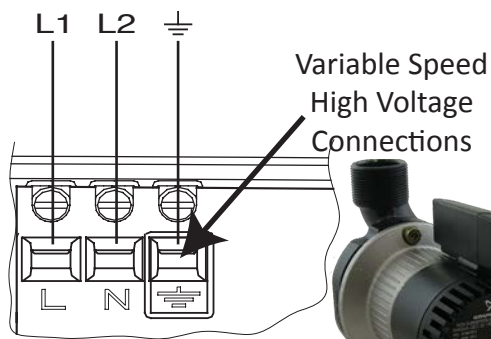

Figure 5: Variable Speed Pump High Voltage Connections

Variable Speed High Voltage Connections



Pump high voltage wiring from “L” side of contactor (*communicating UPM board*)

Pump high voltage wiring from “L” side of contactor (*24VAC/non-communicating UPM*)

Black wires with fuses in kit



Remove cover to access high voltage connections

8. Complete high voltage wiring to second pump (if applicable). If a second pump is installed, the second pump must be wired to the Grundfos controller, so that the relay in the controller can engage/disengage the pump based upon heat pump operation (for example, first or second stage operation/flow rate). Refer to Figure 6 for wiring. Run high voltage wiring from the “L” side of the compressor contactor to the Grundfos controller terminals. Run wiring from the controller to the second pump. Wiring must meet applicable code requirements, including requirements for wire protection, such as conduit. Wire size must be at least 14 AWG copper conductor.
9. Complete flushing/purging of ground loop piping. Do not attempt to start the pump(s) until the system has been filled, purged of air, and pressurized if applicable (pressurized flow centers). Refer to Geo-Flo’s flush cart manual at www.geo-flo.com.
10. Program Grundfos controller. Refer to the Grundfos UPC-GEO Controller installation manual that ships with the variable speed flow center package for programming details.

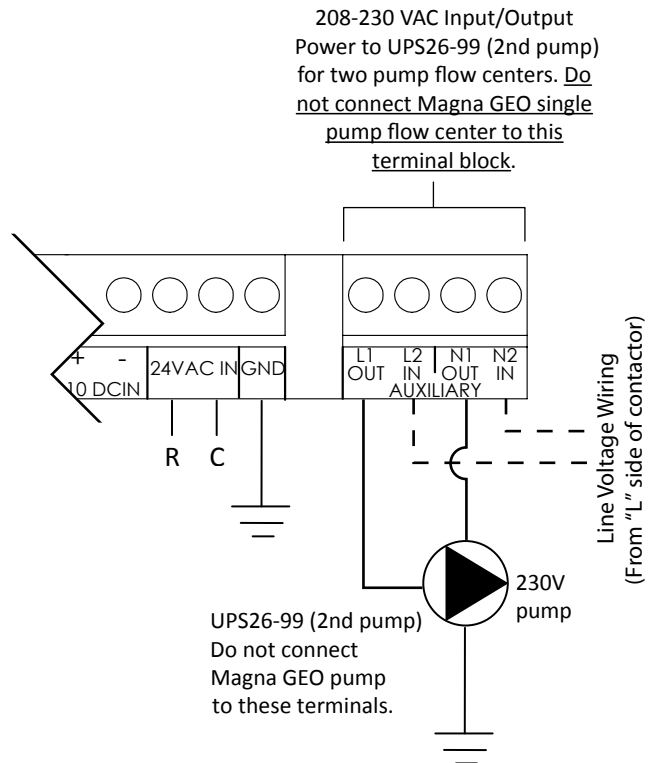

Figure 6: High Voltage to Second Pump

11. Test the heat pump/flow center. Verify flow center/heat pump operation in both heating and cooling modes. Controller will display heat pump operating mode (first or second stage), as well as entering/leaving water temperatures and flow rate (if equipped with flow sensor).
12. Record start up data for future reference.

IMPORTANT NOTES:

- Variable speed flow centers with "Flow and Temperature" control can display flow rate (in GPM) on the controller screen, which also allows the display of Heat of Extraction and Heat of Rejection (HE/HR). The "Temperature" version of the controller does not include a flow sensor, and thus cannot display flow rate or HE/HR.
- If "Flow Mode" is desired, "Flow and Temperature" control is required. Either controller ("Flow and Temperature" or "Temperature" version) can operate in "ΔT Mode" (temperature difference). R, C, ACC and Y2 connections are needed to use the "Flow Mode" setting at the flow center controller. Only R, C, and ACC are needed for ΔT Mode.