

**Wiring Kit Part # 4129 (Replacement Components)
Closed Loop Variable Speed Flow Centers &
Two-Valve Applications for Open Loop Systems
For use with Heat Pumps with Communicating UPM***

*Infinity/Evolution controls (communicating Unit Protection Module)

**FCD23, FCP13, FCM13, FCN13, FCK13,
FCD34, FCP24, FCM24, FCN24, &
FCK24 Geothermal Flow Centers**

**MVBR3F and MVBR4F
Motorized Solenoid Valves
For Open Loop Systems**

Installation Instructions

This wiring kit is used for connecting variable speed flow center pump(s) or open loop solenoid valves to a heat pump with a communicating UPM (Unit Protection Module). *Please read these instructions entirely before attempting to connect the flow center pump(s) or solenoid valves.*

1. Verify package contents. Included in the package are a wiring harness extension for connector P5 at the UPM board, a red wire, and these installation instructions.
2. Complete ground loop and/or heat pump piping. For closed loop systems, finish piping and flushing before wiring the pump(s) to avoid loop fluid in contact with the pump(s). For open loop systems, install solenoid valve(s), flow regulator(s), and other components (see page 4 for details).



WARNING: MAKE SURE THAT HEAT PUMP POWER IS DISCONNECTED AND THE AREA AROUND THE PUMP(S) IS COMPLETELY DRY BEFORE PROCEEDING TO STEP #3.

SAFETY CONSIDERATIONS

Improper installation, adjustment, alteration, service, maintenance, or use can cause explosion, fire, electrical shock, or other conditions which may cause death, personal injury, or property damage. Consult a qualified installer, service agency, or your distributor or branch for information or assistance. The qualified installer or agency must use factory-authorized kits or accessories when modifying this product. Refer to the individual instructions packaged with the kits or accessories when installing.

Follow all safety codes. Wear safety glasses, protective clothing, and work gloves. Use quenching cloth for brazing operations. Have fire extinguisher available. Read these instructions thoroughly and follow all warnings or cautions included in literature and attached to the unit. Consult local building codes and current editions of the National Electrical Code (NEC) NFPA 70. In Canada, refer to current editions of the Canadian electrical code CSA 22.1.

Recognize safety information. This is the safety-alert symbol . When you see this symbol on the unit and in instructions or manuals, be alert to the potential for personal injury. Understand these signal words; DANGER, WARNING, and CAUTION. These words are used with the safety-alert symbol. DANGER identifies the most serious hazards which will result in severe personal injury or death. WARNING signifies hazards which could result in personal injury or death. CAUTION is used to identify unsafe practices which would result in minor personal injury or product and property damage. NOTE is used to highlight suggestions which will result in enhanced installation, reliability, or operation.



WARNING

ELECTRICAL SHOCK HAZARD

Failure to follow this warning could result in personal injury or death.

Before installing, modifying, or servicing system, main electrical disconnect switch must be in the OFF position. There may be more than 1 disconnect switch. Lock out and tag switch with a suitable warning label.

VARIABLE SPEED FLOW CENTERS (for open loop systems, skip to page 4)

3. Complete high voltage wiring to the pump(s).

HIGH VOLTAGE WIRING, variable speed pump: Using the other kit shipped with the flow center (part #3977), attach the black wires with the fuse holders in the kit to the “L” side of the compressor contactor (see CAUTION below). Connect field-supplied wiring from the black wires to the pump terminals (refer to Figure 1). Wiring must meet all applicable code requirements, including requirements for wire protection, such as conduit. Wire size must be at least 14 AWG copper conductor.

CAUTION: DO NOT CONNECT THE VARIABLE SPEED PUMP TO THE “T” SIDE OF THE HEAT PUMP CONTACTOR. THE VARIABLE SPEED PUMP MUST BE POWERED AT ALL TIMES. AFTER VERIFYING THAT THE HEAT PUMP BREAKER AND WIRE SIZE IS SUFFICIENT FOR BOTH THE HEAT PUMP AND THE FLOW CENTER PUMP(S), CONNECT THE VARIABLE SPEED PUMP TO THE “L” SIDE OF THE CONTACTOR.

From “L” side of heat pump contactor

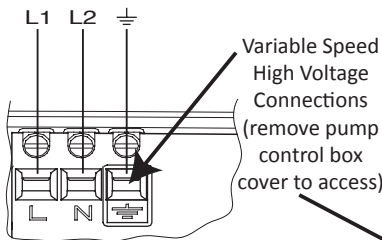
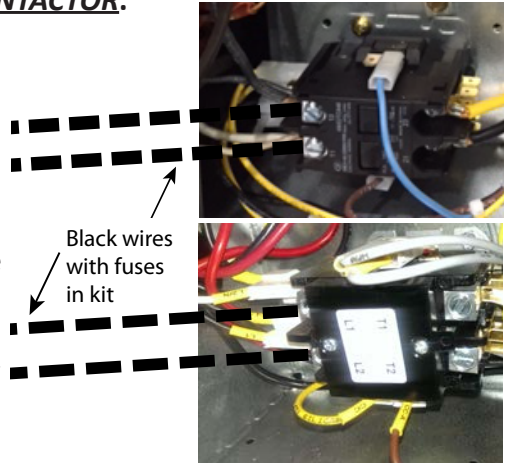

Figure 1: Variable Speed Pump High Voltage Connections



Pump high voltage wiring from “L” side of contactor (communicating UPM board)

Pump high voltage wiring from “L” side of contactor (non-communicating UPM board)



Use this section (in addition to the section above) if the flow center includes a variable speed pump AND a 2nd pump, which is 3-speed. (Flow center models: FCD34, FCP24, FCM24, FCN24, FCK24). If a 2nd pump is not installed, skip to step #4.

HIGH VOLTAGE WIRING, second (3-speed) pump: If a second pump is installed, the second pump must be wired to the Grundfos controller, so that the relay in the controller can engage/disengage the pump based upon heat pump operation (for example, first or second stage operation/flow rate). Refer to Figure 2 for wiring. Run high voltage wiring from the “L” side of the compressor contactor to the Grundfos controller terminals. Run wiring from the controller to the second pump. Wiring must meet applicable code requirements, including requirements for wire protection, such as conduit. Wire size must be at least 14 AWG copper conductor.

4. Wire LOW VOLTAGE CONNECTIONS (heat pumps with communicating UPM board only). Remove connector PL5 from the UPM board (see Figure 3 and Table 1). Replace with wiring harness extension from kit, and re-attach original PL5 connector to the other end (male pins) of the extension. Disconnect red wire from secondary side of transformer (see Figure 3). Replace with red wire from kit (piggy-back end), and re-attach original red wire to the piggy-back terminal. Use stripped end of the red wire to connect to terminal R at the flow center.

208-230 VAC Input/Output Power to UPS26-99 (2nd pump) for two pump flow centers. Do not connect Magna GEO single pump flow center to this terminal block.

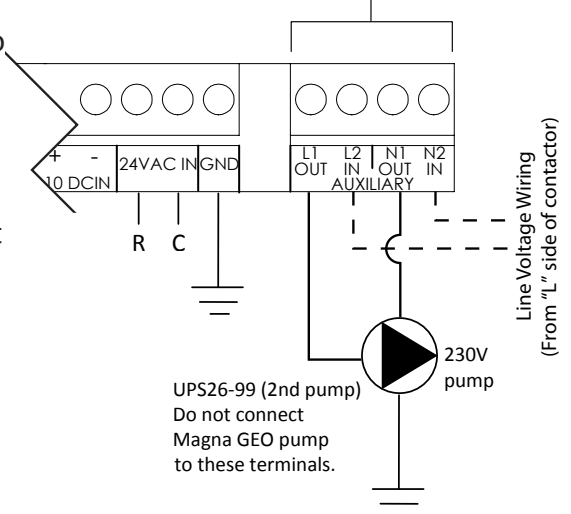

Figure 2: High Voltage to 2nd Pump (Variable Speed Flow Center Only)

IMPORTANT: Step #4 is for units with communicating UPM. If heat pump has non-communicating UPM, use kit with brown wire (piggy-back spade connector on one end). DO NOT use wiring harness in Figure 3.

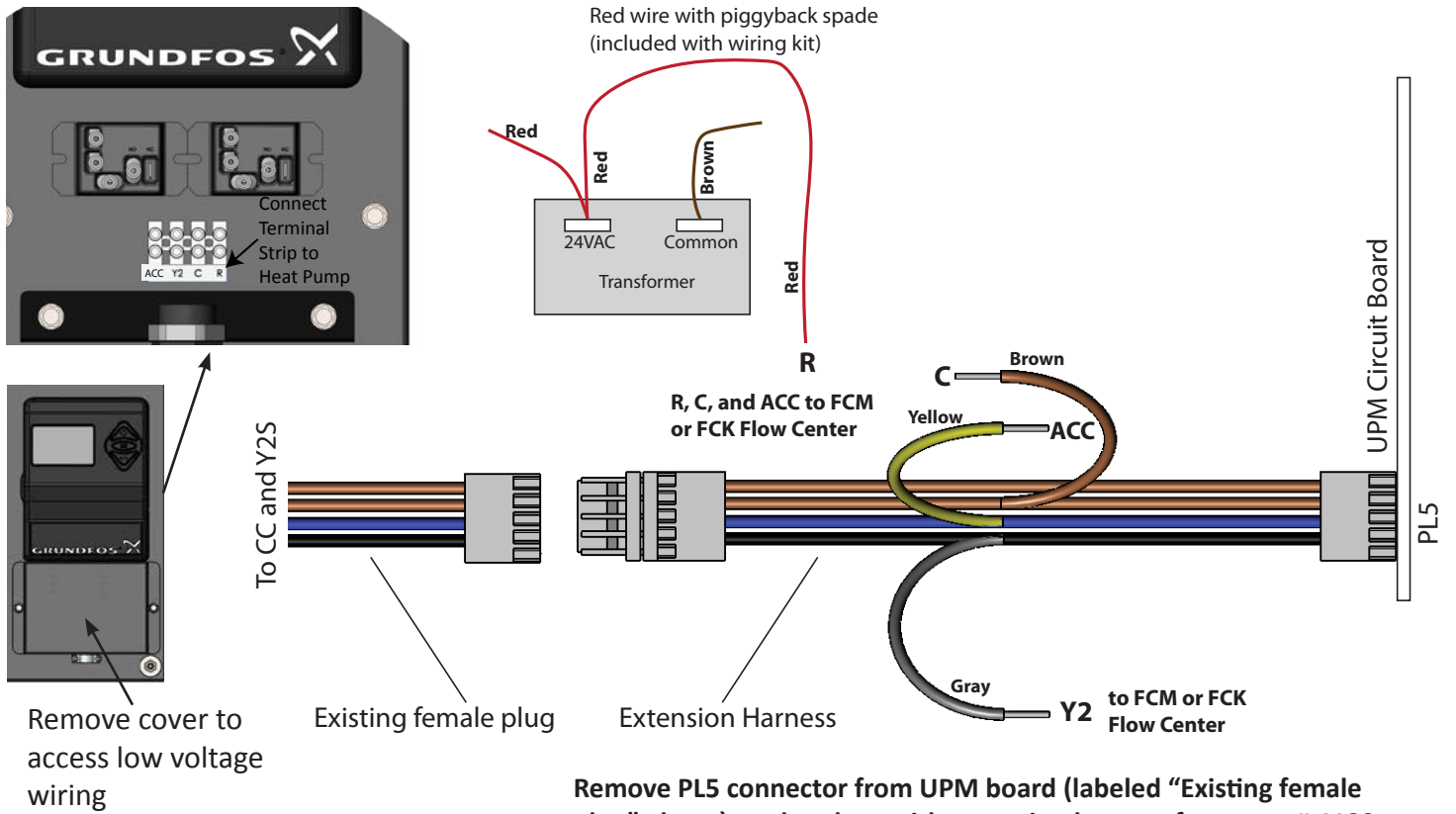

Figure 3: Low Voltage Wiring at Heat Pump (Communicating Controls)

Remove PL5 connector from UPM board (labeled “Existing female plug” above), and replace with extension harness from part # 4129 wiring kit (available from Replacement Components). Connect PL5 harness to the male pins of the extension harness.

IMPORTANT: Figure 3 and Table 1 are for heat pumps with communicating UPM board only. If heat pump has non-communicating UPM board, use kit with brown wire (piggy-back spade connector on one end). DO NOT use wiring harness in Figure 3.

Heat Pumps with Communicating UPM Board*

Low Voltage Connection at Flow Center Panel (see Figure 2)	Heat Pumps with Communicating UPM Board*
ACC	Yellow wire in P5 extension harness (Figure 3)
Y2	Gray wire in P5 extension harness (Figure 3)
C	Brown wire in P5 extension harness (Figure 3)
R	Red wire with piggyback spade, connected at transformer terminal (Figure 3)

CAUTION: Failure to wire per instructions may cause UPM fuse failures for low voltage circuit

*Infinity/Evolution

Table 1: Low Voltage Wiring -- Heat Pumps with Communicating UPM Board

FLOW CENTER OPERATION NOTES:

- Variable speed flow centers with “Flow and Temperature” control can display flow rate (in GPM) on the controller screen, which also allows the display of Heat of Extraction and Heat of Rejection (HE/HR). The “Temperature” version of the controller does not include a flow sensor, and thus cannot display flow rate or HE/HR.
- If “Flow Mode” is desired, “Flow and Temperature” control is required. Either controller (“Flow and Temperature” or “Temperature” version) can operate in “ΔT Mode” (temperature difference). R, C, ACC and Y2 connections are needed to use the “Flow Mode” setting at the flow center controller. Only R, C, and ACC are needed for ΔT Mode.

OPEN LOOP SYSTEMS (steps 1 & 2 on page 1)

3. Before wiring solenoid valves, review Figures 4 and 5 (below) to determine piping arrangement. Open loop systems require a water solenoid valve to turn on the water when the heat pump compressor is energized, and to turn off the water when the compressor is off. A slow-closing motorized valve (MVBR3F or MVBR4F) is recommended to help reduce water hammer. A flow regulator limits water flow to avoid using more water than the heat pump requires, which wastes water and increases pumping costs. A hose kit provides vibration isolation, as well as convenient fittings to install P/T (pressure/temperature) plugs for checking water temperature and pressure drop at startup and during troubleshooting. Figure 4 shows the typical piping arrangement for a single solenoid valve. For single speed heat pumps and smaller two-stage heat pumps (3 tons and smaller), one valve is typical. For larger two-stage heat pumps, there is an opportunity to save a significant amount of energy (and avoid wasting water) with the use of two solenoid valves, one for first stage, and both for second stage (Figure 5).

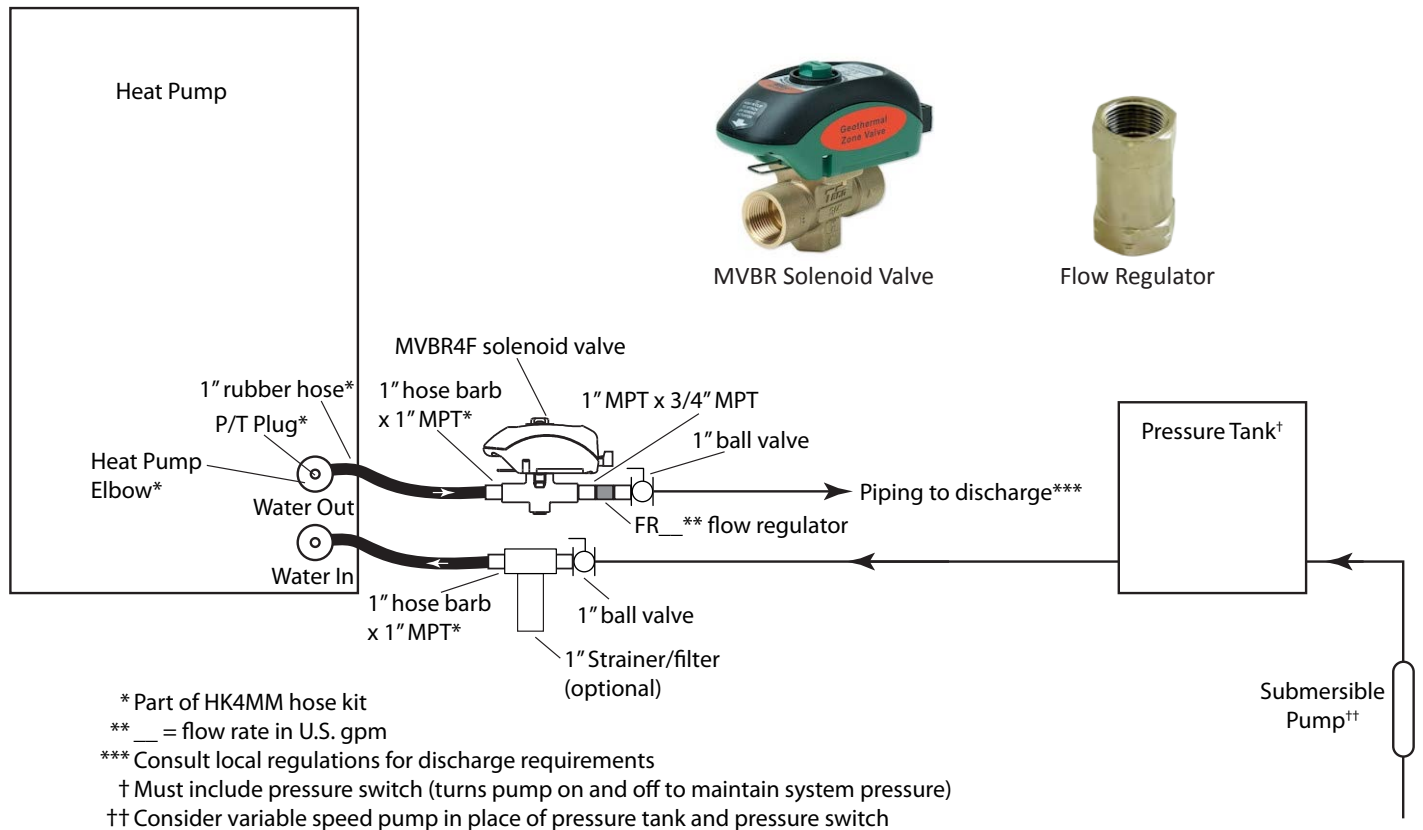

Figure 4: Single Solenoid Valve

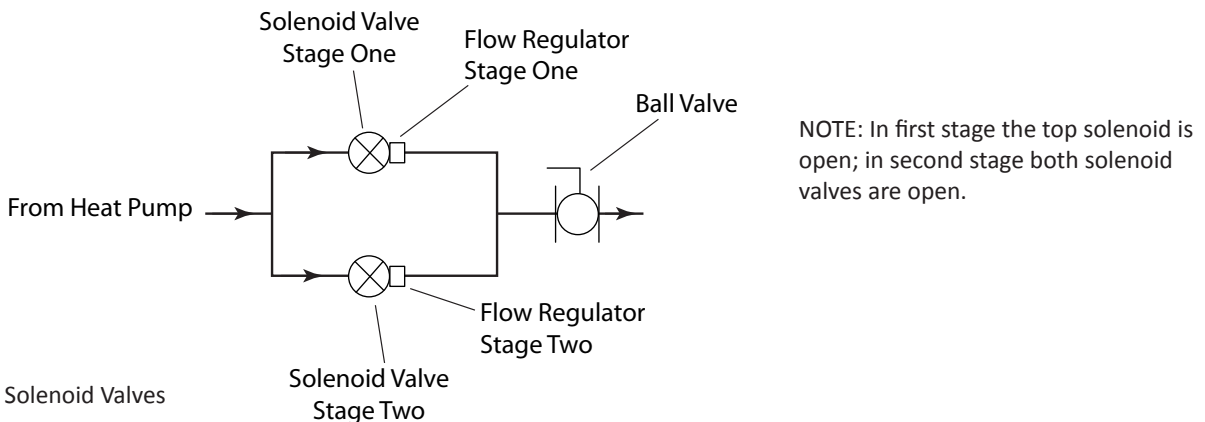

Figure 5: Two Solenoid Valves

4. Based upon the piping arrangement (one or two valves) and heat pump controls (24VAC or communicating), select the proper wiring diagram. The diagrams below provide wiring for 24VAC and communicating controls for one valve and two valve systems. Consult the heat pump installation manual for additional details on sequence of operation and other requirements.

24VAC Controls

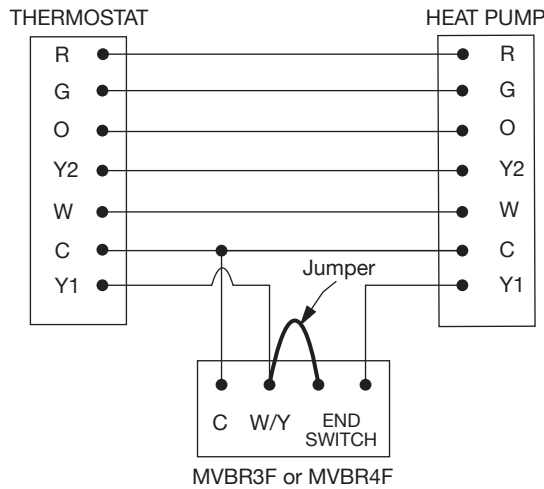

Figure 6a: Single Solenoid Valve

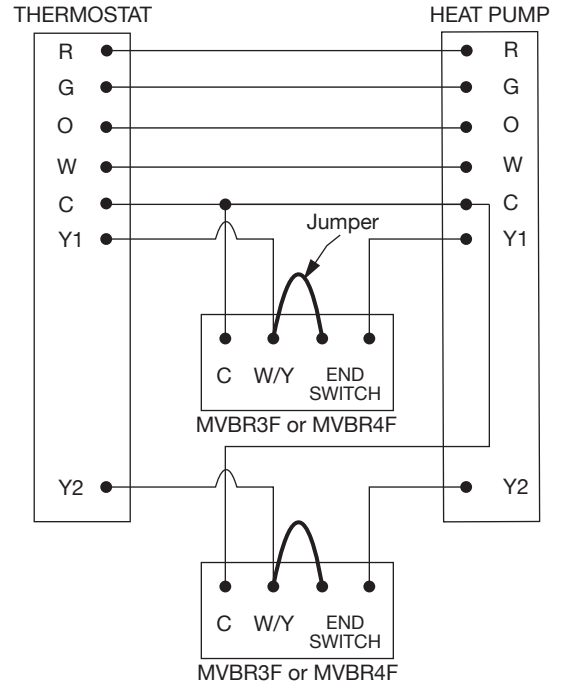

Figure 6b: Two Solenoid Valves

Communicating Controls

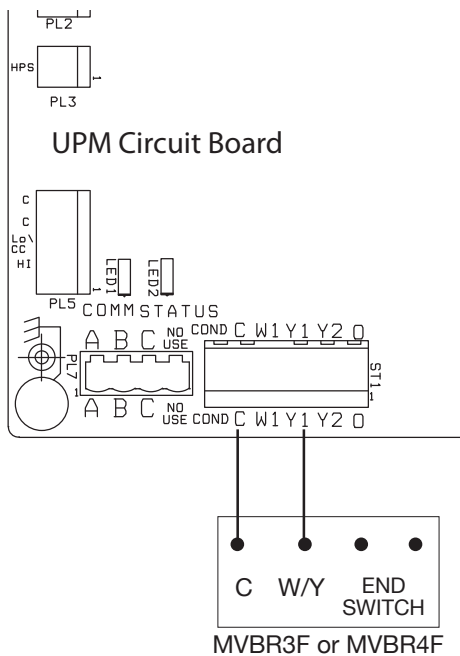

Figure 7: Single Solenoid Valve

Communicating controls notes:

1. The UPM board includes a delay at terminal Y1 (connector ST1) that delays the compressor from starting after receiving a call from the thermostat to provide time for the valve to fully open. Therefore, the end switch is not used for communicating controls.
2. For systems with two valves, see Figure 8.

IMPORTANT:

Ensure that wire colors match up when connecting harness (brown to brown, blue to blue, black to black).

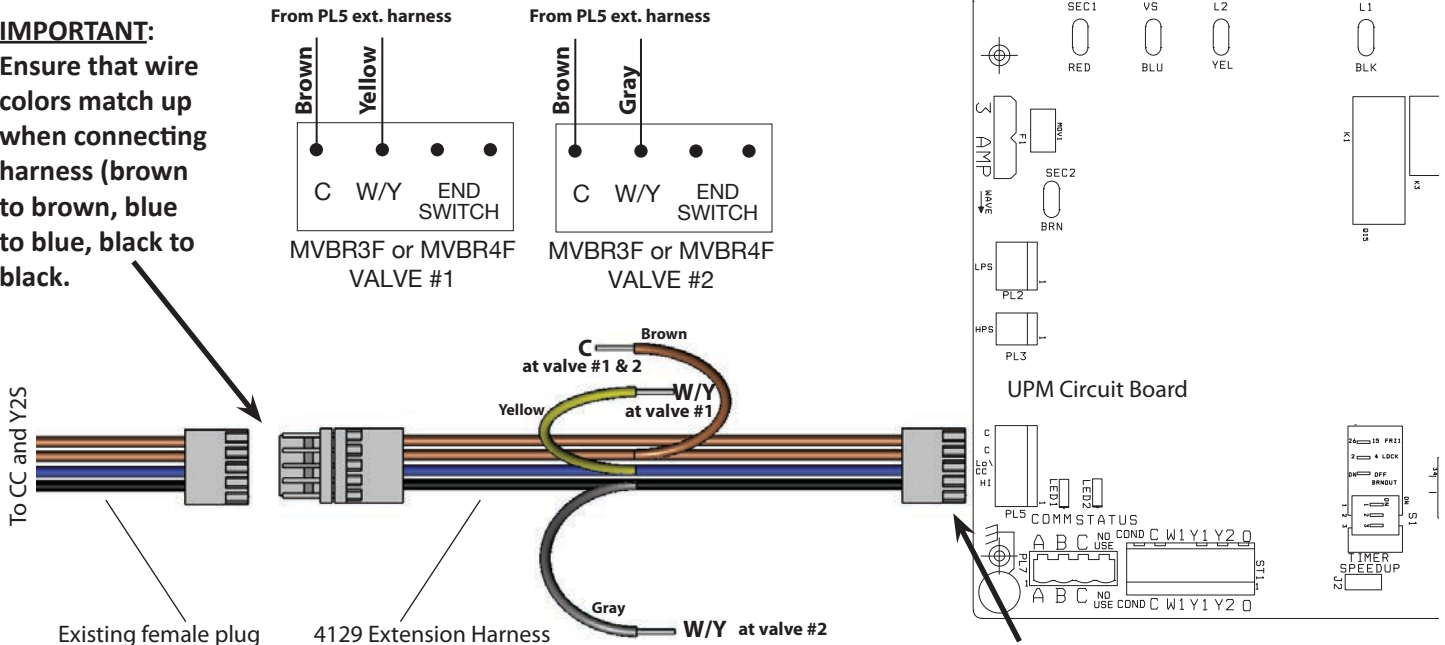

IMPORTANT: Position plug with brown wire on top and plastic plug (no wire in socket) on the bottom.

Figure 8: Two Solenoid Valves

Communicating controls notes:

1. Y2 (connector ST1) is used for a utility curtailment input, and is not available for use as an output for the second valve. However, the wiring harness extension (part # 4129) used for variable speed flow centers (closed loop applications) provides a second stage connection as shown above (gray/brown wires). The wiring kit should be used for systems with two solenoid valves (yellow wire for stage 1, gray wire for stage 2, brown wire for common to both valves).
2. The UPM board delays the compressor from starting after receiving a call from the thermostat to provide time for the valve to fully open. Therefore, the end switch is not used for communicating controls.

5. Each MVBR3F/MVBR4F valve may use up to 11.5 VA. Verify heat pump installation manual to ensure that heat pump transformer is large enough for heat pump controls, water solenoid valve(s), and any other accessories. Other water solenoid valves may have higher VA requirements than the MVBR3F and MVBR4F valves.