



# Installation Instructions

## CONTENTS


	Page
SAFETY CONSIDERATIONS .....	1
INSTALLATION .....	1
Step 1-Provide Unit Support .....	2
ROOF CURB .....	2
SLAB MOUNT .....	2
ALTERNATE UNIT SUPPORT .....	2
Step 2-Field Fabricate Ductwork .....	2
Step 3-Install External Trap for Condensate Drain .....	2
Step 4-Rig and Place Unit .....	2
POSITIONING .....	4
Step 5 — Install Flue Hood .....	4
Step 6 — Install Gas Piping .....	4
Step 7 — Make Electrical Connections .....	8
FIELD POWER SUPPLY .....	8
FIELD CONTROL WIRING .....	8
HEAT ANTICIPATOR SETTINGS .....	8
Step 8 — Adjust Factory-Installed Options .....	17
COBRA™ ENERGY RECOVERY UNITS .....	17
HUMIDI-MIZER™ ADAPTIVE DEHUMIDIFICATION SYSTEM .....	17
MANUAL OUTDOOR-AIR DAMPER .....	17
CONVENIENCE OUTLET .....	17
NOVAR CONTROLS .....	17
PREMIERLINK™ CONTROL .....	19
OPTIONAL ECONOMISER IV AND ECONOMISER2 .....	22
ECONOMISER IV STANDARD SENSORS .....	23
ECONOMISER IV CONTROL MODES .....	24
Step 9 — Adjust Evaporator-Fan Speed .....	29
PRE-START-UP .....	45
START-UP .....	45
SERVICE .....	50
TROUBLESHOOTING .....	58
START-UP CHECKLIST .....	63

## SAFETY CONSIDERATIONS

Installation and servicing of air-conditioning equipment can be hazardous due to system pressure and electrical components. Only trained and qualified service personnel should install, repair, or service air-conditioning equipment.

Untrained personnel can perform basic maintenance functions of cleaning coils and filters and replacing filters. All other operations should be performed by trained service personnel. When working on air-conditioning equipment, observe precautions in the literature, tags and labels attached to the unit, and other safety precautions that may apply.

Follow all safety codes. Wear safety glasses and work gloves. Use quenching cloth for unbrazing operations. Have fire extinguishers available for all brazing operations.

Recognize safety information. This is the safety-alert symbol . When you see this symbol on the furnace and in instructions or manuals, be alert to the potential for personal injury.

Understand the signal words DANGER, WARNING, and CAUTION. These words are used with the safety-alert symbol. DANGER identifies the most serious hazards which **will** result in severe personal injury or death. WARNING signifies a hazard which **could** result in personal injury or death. CAUTION is used to identify unsafe practices which **may** result in minor personal injury or product and property damage. NOTE is used to highlight suggestions which **will** result in enhanced installation, reliability, or operation.

### WARNING

#### ELECTRICAL SHOCK HAZARD

Failure to follow this warning could cause personal injury or death.

Before performing service or maintenance operations on unit, turn off main power switch to unit and install lockout tag. Ensure electrical service to rooftop unit agrees with voltage and amperage listed on the unit rating plate.

# ⚠ WARNING

## FIRE, EXPLOSION HAZARD

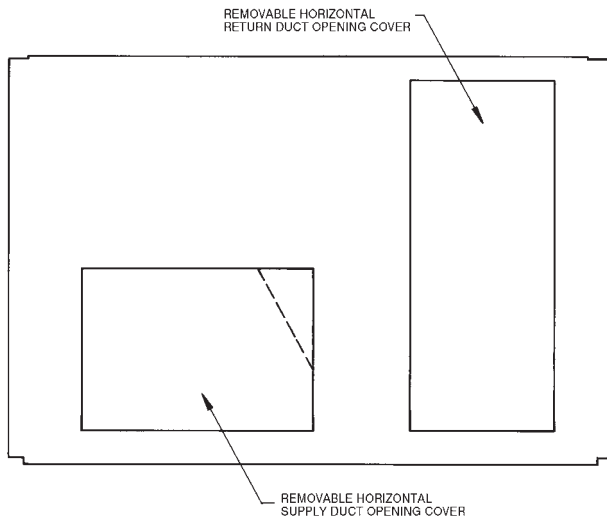
Failure to follow this warning could death and/or property damage.

Disconnect gas piping from unit when leak testing at pressure greater than  $\frac{1}{2}$  psig. Pressures greater than  $\frac{1}{2}$  psig will cause gas valve damage resulting in hazardous condition. If gas valve is subjected to pressure greater than  $\frac{1}{2}$  psig, it *must* be replaced before use. When pressure testing field-supplied gas piping at pressures of  $\frac{1}{2}$  psig or less, a unit connected to such piping must be isolated by manually closing the gas valve(s).

48HE,HJ

## INSTALLATION

Unit is shipped in the vertical discharge configuration. To convert to horizontal discharge application, remove duct opening covers. Using the same screws, install covers on duct openings in basepan of unit with insulation-side down. Seals around openings must be tight. (See Fig. 1.)



C06108

Fig. 1 – Horizontal Conversion Panels

### Step 1 —Provide Unit Support

#### **ROOF CURB**

Assemble and install accessory roof curb in accordance with instructions shipped with curb. (See Fig. 2.) Install insulation, cant strips, roofing felt, and counter flashing as shown. *Ductwork must be attached to curb, not to the unit.* If electric control power or gas service is to be routed through the basepan, attach the accessory thru-the-bottom service connections to the basepan in accordance with the accessory installation instructions. Connections must be installed before unit is set on roof curb.

**IMPORTANT:** The gasketing of the unit to the roof curb is critical for a watertight seal. Install gasket supplied with the roof curb as shown in Fig. 2. Improperly applied gasket can result in air leaks and poor unit performance.

Curb should be level. Unit leveling tolerances are shown in Fig. 3. This is necessary for unit drain to function properly. Refer to Accessory Roof Curb Installation Instructions for additional information as required.

#### **SLAB MOUNT (Horizontal Units Only)**

Provide a level concrete slab that extends a minimum of 6 in. beyond unit cabinet. Install a gravel apron in front of

condenser-coil air inlet to prevent grass and foliage from obstructing airflow.

**NOTE:** Horizontal units may be installed on a roof curb if required.

### ALTERNATE UNIT SUPPORT

When the curb or adapter cannot be used, support unit with sleeper rails using unit curb or adapter support area. If sleeper rails cannot be used, support the long sides of the unit with a minimum of 3 equally spaced 4-in. x 4-in. pads on each side.

### Step 2 —Field Fabricate Ductwork

Secure all ducts to roof curb and building structure on vertical discharge units. *Do not connect ductwork to unit.* For horizontal applications, field-supplied isolation flanges should be attached to horizontal discharge openings and all ductwork should be secured to the flanges. Insulate and weatherproof all external ductwork, joints, and roof openings with counter flashing and mastic in accordance with applicable codes.

Ducts passing through an unconditioned space must be insulated and covered with a vapor barrier.

If a plenum return is used on a vertical unit, the return should be ducted through the roof deck to comply with applicable fire codes.

A minimum clearance is not required around ductwork. Cabinet return-air static pressure (a negative condition) shall not exceed 0.35 in. wg with economizer or 0.45 in. wg without economizer.

These units are designed for a minimum continuous return-air temperature in heating of 50°F (dry bulb), or an intermittent operation down to 45°F (dry bulb), such as when used with a night setback thermostat.

To operate at lower return-air temperatures, a field-supplied outdoor air temperature control must be used to initiate both stages of heat when the temperature is below 45°F. Indoor comfort may be compromised when these lower air temperatures are used with insufficient heating temperature rise.

### Step 3 —Install External Trap for Condensate Drain

The unit's  $\frac{3}{4}$ -in. condensate drain connections are located on the bottom and side of the unit. Unit discharge connections do not determine the use of drain connections; either drain connection can be used with vertical or horizontal applications.

When using the standard side drain connection, ensure the plug (Red) in the alternate bottom connection is tight before installing the unit.

To use the bottom drain connection for a roof curb installation, relocate the factory-installed plug (Red) from the bottom connection to the side connection. The center drain plug looks like a star connection, however it can be removed with a  $\frac{1}{2}$ -in. socket drive extension. (See Fig. 4.) The piping for the condensate drain and external trap can be completed after the unit is in place.


All units must have an external trap for condensate drainage. Install a trap 4-in. deep and protect against freeze-up. If drain line is installed downstream from the external trap, pitch the line away from the unit at 1 in. per 10 ft of run. Do not use a pipe size smaller than the unit connection ( $\frac{3}{4}$  in.). (See Fig. 5.)

### Step 4 —Rig and Place Unit

Inspect unit for transportation damage, and file any claim with transportation agency. Keep unit upright and do not drop. Spreader bars are not required if top crating is left on unit, and rollers may be used to move unit across a roof. Level by using unit frame as a reference. See Table 1 and 2 and Fig. 6 for additional information. Operating weight is shown in Table 1 and 2 and Fig. 6.

CONNECTOR PKG. ACCY.	B	C	D ALT DRAIN HOLE	GAS	POWER	CONTROL	ACCESSORY POWER
CRBTMPWR001A01	1 -9 11/16 [551]	1 -4 [406]	1 3/4 [44.5]	3/4 [19] NPT	3/4 [19] NPT	1/2 [12.7]	1/2 [12.7]
CRBTMPWR002A01				1 1/4 [31.7]	1 1/4 [31.7]		
CRBTMPWR003A01				1/2 [12.7] NPT	3/4 [19] NPT		
CRBTMPWR004A01				3/4 [19] NPT	1 1/4 [31.7]		

ROOF CURB ACCESSORY	A	UNIT SIZE
CRRFCURB001A01	1 -2 [356]	48HJ004-007
CRRFCURB002A01	2 -0 [610]	48HE003-006

- NOTES:
1. Roof curb accessory is shipped disassembled.
  2. Insulated panels.
  3. Dimensions in [ ] are in millimeters.
  4. Roof curb: galvanized steel.
  5. Attach ductwork to curb (flanges of duct rest on curb).
  6. Service clearance: 4 ft on each side.
  7.  Direction of airflow.
  8. Connector packages CRBTMPWR001A01 and 002A01 are for thru-the-curb type gas. Packages CRBTMPWR003A01 and 004A01 are for thru-the-bottom type gas connections.

48HE,HJ

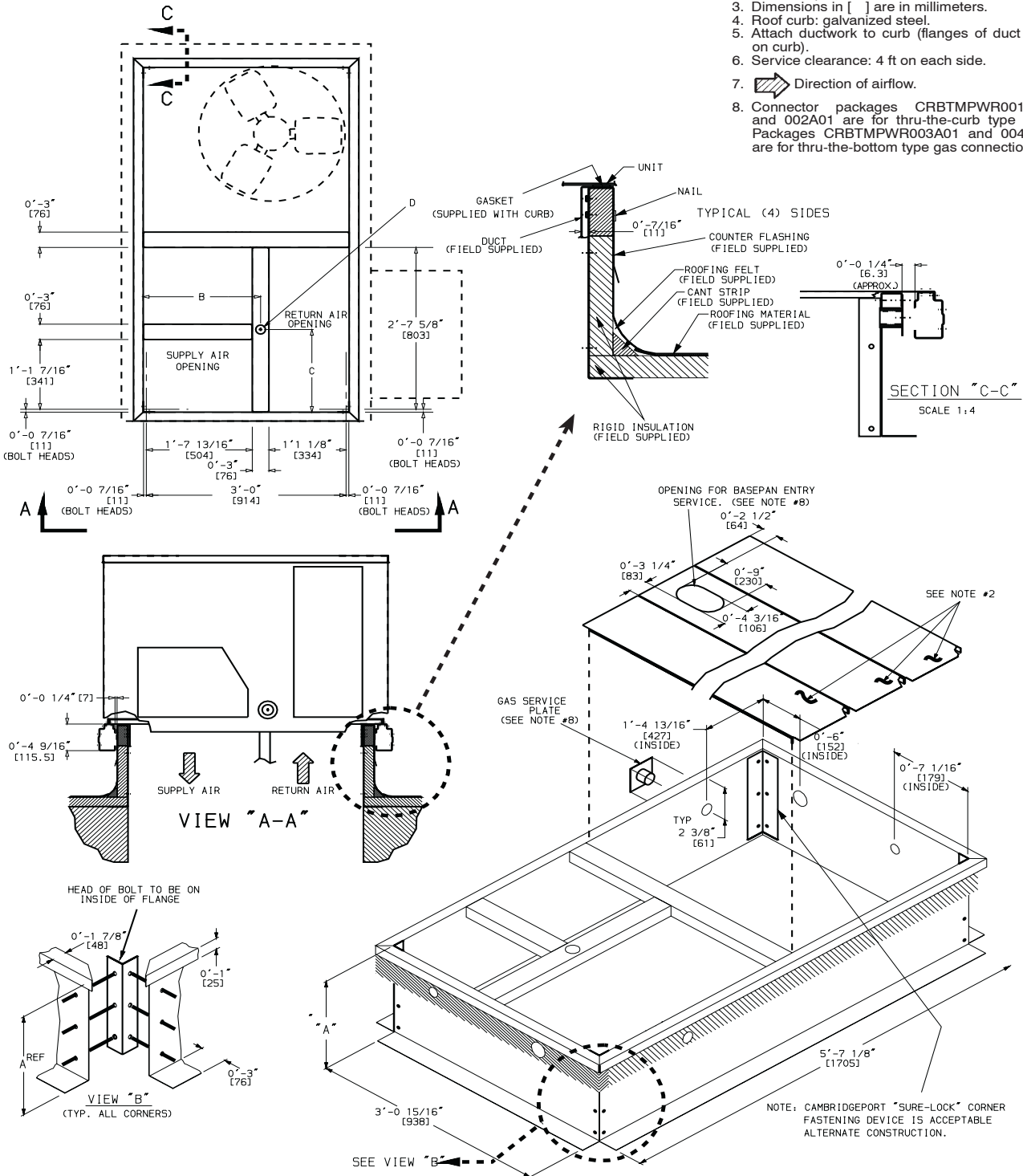


Fig. 2 – Roof Curb Details

C06109

Lifting holes are provided in base rails as shown in Fig. 8 and 9. Refer to rigging instructions on unit.

**⚠ WARNING**

**PROPERTY DAMAGE HAZARD**

Failure to follow this warning could result in personal injury, death and property damage.

All panels must be in place when rigging and lifting.

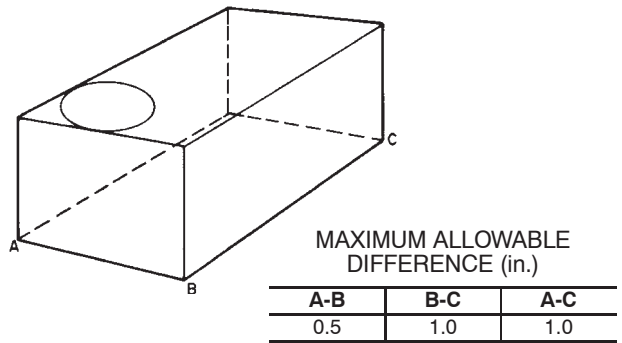
**positioning**

Maintain clearance around and above unit to provide minimum distance from combustible materials, proper airflow, and service access. (See Fig. 7, 8 and 9.)

Position unit on roof curb so that the following clearances are maintained: 1/4 in. clearance between the roof curb and the base rail inside the front and rear, 0.0 in. clearance between the roof curb and the base rail inside on the duct end of the unit. This will result in the distance between the roof curb and the base rail inside on the condenser end of the unit being approximately equal to Fig. 2, section C-C.

Do not install unit in an indoor location. Do not locate unit air inlets near exhaust vents or other sources of contaminated air.

48HE,HJ



**Fig. 3 – Unit Leveling Tolerances**

C06110

Be sure that unit is installed such that snow will not block the combustion intake or flue outlet.

Unit may be installed directly on wood flooring or on Class A, B, or C roof-covering material when roof curb is used.

Although unit is weatherproof, guard against water from higher level runoff and overhangs.

Locate mechanical draft system flue assembly at least 48 in. from an adjacent building or combustible material. When unit is located adjacent to public walkways, flue assembly must be at least 7 ft above grade.

**NOTE:** When unit is equipped with an accessory flue discharge deflector, allowable clearance is 18 inches.

Flue gas can deteriorate building materials. Orient unit such that flue gas will not affect building materials.

Adequate combustion-air space must be provided for proper operation of this equipment. Be sure that installation complies with all local codes and Section 5.3, Air for Combustion and Ventilation, NFGC (National Fuel Gas Code), ANSI (American National Standards Institute) Z223.1-1984 and addendum Z223.1a-1987. In Canada, installation must be in accordance with the CAN1.B149.1 and CAN1.B149.2 installation codes for gas burning appliances.

Flue vent discharge must have a minimum horizontal clearance of 4 ft from electric and gas meters, gas regulators, and gas relief equipment.

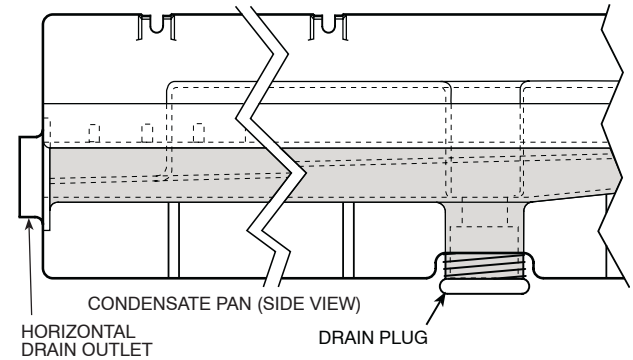
After unit is in position, remove shipping materials and rigging skids.

**Step 5 —Install Flue Hood**

Flue hood is shipped screwed to the burner compartment access panel. Remove from shipping location and, using screws provided, install flue hood in location shown in Fig. 8 and 9.

For units being installed in California Air Quality Management Districts which require NOx emissions of 40 nanograms/joule or less, a low NOx unit must be installed.

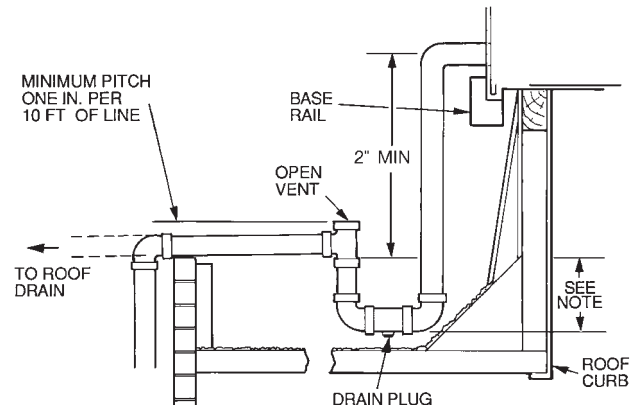
**NOTE:** Low NOx units are available for 3 to 5 ton units.



**NOTE:** Drain plug is shown in factory-installed position.

C06003

**Fig. 4 – Condensate Drain Pan**



**NOTE:** Trap should be deep enough to offset maximum unit static difference. A 4-in. trap is recommended.

C06004

**Fig. 5 – Condensate Drain Piping Details**

**Step 6 —Install Gas Piping**

Unit is equipped for use with type of gas shown on nameplate. Refer to local building codes, or in the absence of local codes, to ANSI Z223.1-1984 and addendum Z223.1A-1987 entitled National Fuel Gas Code. In Canada, installation must be in accordance with the CAN1.B149.1 and CAN1.B149.2 installation codes for gas burning appliances.

For natural gas applications, gas pressure at unit gas connection must not be less than 4 in. wg or greater than 13 in. wg while the unit is operating. On 48HJ005-007 high-heat units, the gas pressure at unit gas connection must not be less than 5 in. wg or greater than 13 in. wg while the unit is operating. For propane applications, the gas pressure must not be less than 5 in. wg or greater than 13 in. wg at the unit connection.

Size gas supply piping for 0.5 in. wg maximum pressure drop. Do not use supply pipe smaller than unit gas connection.

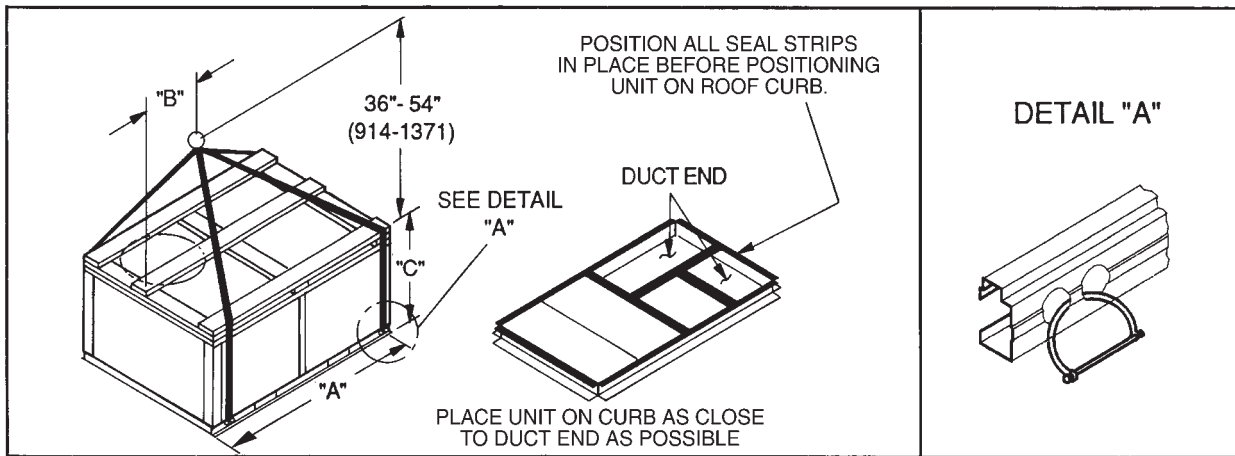


Fig. 6 – Rigging Details

C06111

48HE,HJ

UNIT 48HE	OPERATING WEIGHT		DIMENSIONS					
			"A"		"B"		"C"	
	lb	kg	in.	mm	in.	mm	in.	mm
003	530	240	73.69	1872	35.50	902	33.31	847
004	540	245	73.69	1872	35.50	902	33.31	847
005	560	254	73.69	1872	35.50	902	33.31	847
006	635	288	73.69	1872	35.50	902	33.31	847
UNIT 48HJ	OPERATING WEIGHT		DIMENSIONS					
			"A"		"B"		"C"	
	lb	kg	in.	mm	in.	mm	in.	mm
004	530	240	73.69	1872	35.50	902	33.31	847
005	540	245	73.69	1872	35.50	902	33.31	847
006	560	254	73.69	1872	35.50	902	33.31	847
007	635	288	73.69	1872	35.50	902	33.31	847

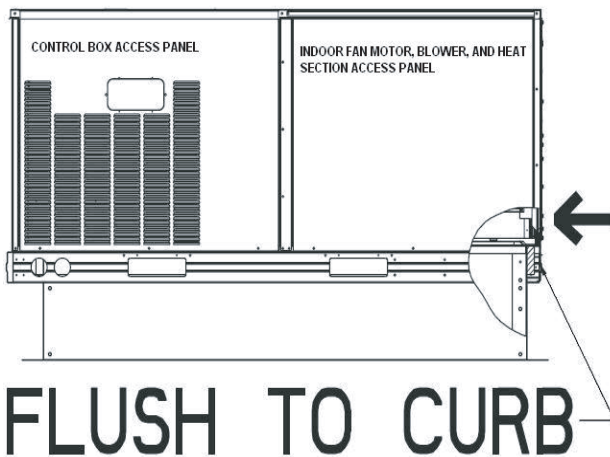


Fig. 7 – Roof Curb Alignment

C06208

Support gas piping as shown in the table in Fig. 11. For example, a 3/4-in. gas pipe must have one field-fabricated support beam every 8 ft. Therefore, an 18-ft long gas pipe would have a minimum of 3 support beams, and a 48-ft long pipe would have a minimum of 6 support beams.

**⚠ WARNING**

**PROPERTY DAMAGE HAZARD**

Failure to follow this warning could result in personal injury, death and property damage.

All panels must be in place when rigging and lifting.

See Fig. 11 for typical pipe guide and locations of external manual gas shutoff valve.

**NOTE:** If accessory thru-the-bottom connections and roof curb are used, refer to the Thru-the-Bottom Accessory Installation Instructions for information on power wiring and gas connection piping. The power wiring, control wiring and gas piping can be routed through field-drilled holes in the basepan. The basepan is specially designed and dimpled for drilling the access connection holes.

**⚠ WARNING**

**FIRE, EXPLOSION HAZARD**

Failure to follow this warning could result in personal injury, death and/or property damage.

When connecting the gas line to the unit gas valve, the installer **MUST** use a backup wrench to prevent damage to the valve.



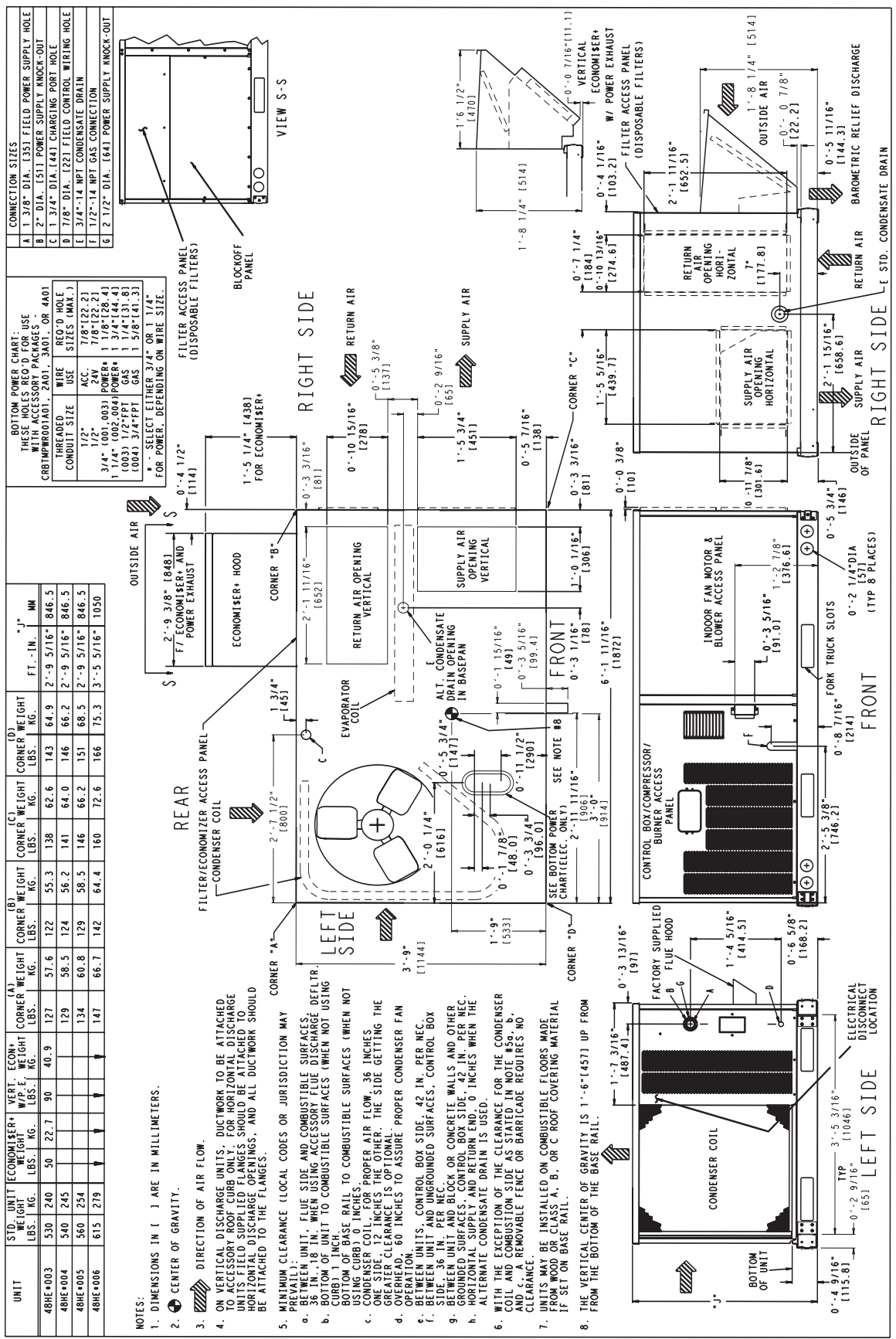
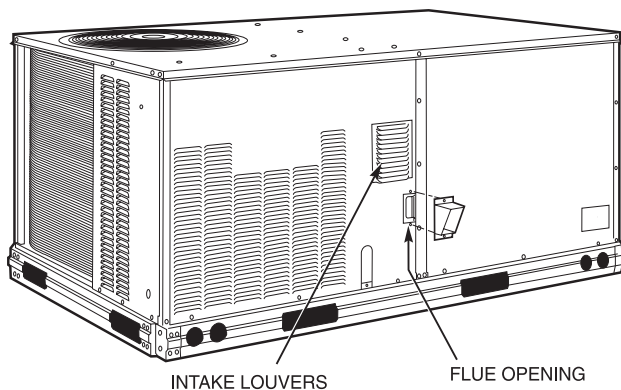
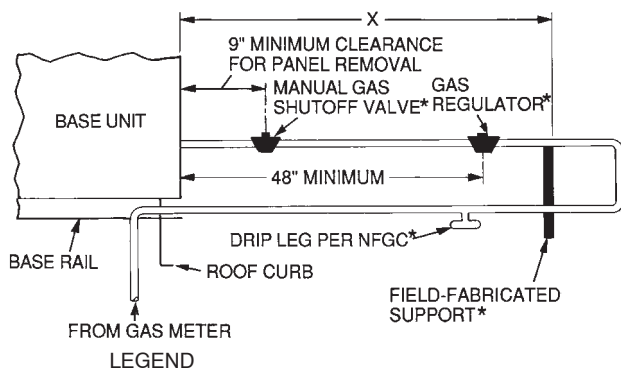


Fig. 9 - 48HE003-006 Base Unit Dimensions



**Fig. 10 – Flue Hood Details**

C06114



**NFGC** — National Fuel Gas Code

\*Field supplied.

NOTE: Follow all local codes.

SPACING OF SUPPORTS

STEEL PIPE NOMINAL DIAMETER (in.)	SPACING OF SUPPORTS X DIMENSION (ft)
1/2	6
3/4 or 1	8
1 1/4 or larger	10

**Fig. 11 – Gas Piping Guide (With Accessory Thru-the-Curb Service Connections)**

C06115

**Step 7 —Make Electrical Connections**

**⚠ WARNING**

**ELECTRICAL SHOCK HAZARD**

Failure to follow this warning could result in personal injury or death.

Unit cabinet must have an uninterrupted, unbroken electrical ground to minimize the possibility of personal injury if an electrical fault should occur. This ground may consist of electrical wire connected to unit ground lug in control compartment, or conduit approved for electrical ground when installed in accordance with NEC (National Electrical Code), ANSI/NFPA (National Fire Protection Association), latest edition, and local electrical codes. *Do not use gas piping as an electrical ground.*

**field power supply**

All units except 208/230-v units are factory wired for the voltage shown on the nameplate. If the 208/230-v unit is to be connected to a 208-v power supply, the transformer *must* be rewired by moving the black wire from the 230-v terminal on the transformer and connecting it to the 200-v terminal from the transformer.

Refer to unit label diagram for additional information. Pigtails are provided for field service. Use factory-supplied splices or UL (Underwriters’ Laboratories) approved copper connector.

When installing units, provide a disconnect per NEC.

All field wiring must comply with NEC and local requirements.

Install conduit through side panel openings indicated in Fig. 8. Route power lines through connector to terminal connections as shown in Fig. 12.

Voltage to compressor terminals during operation must be within voltage range indicated on unit nameplate (also see Tables 3 and 4). On 3-phase units, voltages between phases must be balanced within 2% and the current within 10%. Use the formula shown in Tables 3 and 4, Note 3 to determine the percent voltage imbalance. Operation on improper line voltage or excessive phase imbalance constitutes abuse and may cause damage to electrical components. Such operation would invalidate any applicable Carrier warranty.

**NOTE:** If accessory thru-the-bottom connections and roof curb are used, refer to the Thru-the-Bottom Accessory Installation Instructions for information on power wiring and gas connection piping. The power wiring, control wiring and gas piping can be routed through field-drilled holes in the basepan. The basepan is specially designed and dimpled for drilling the access connection holes. (See Fig. 2.)

**field control wiring**

Install a Carrier-approved accessory thermostat assembly according to installation instructions included with the accessory. Locate thermostat assembly on a solid wall in the conditioned space to sense average temperature in accordance with thermostat installation instructions.

Route thermostat cable or equivalent single leads of colored wire from subbase terminals through connector on unit to low-voltage connections (shown in Fig. 13 and 14).

Connect thermostat wires to matching screw terminals of low-voltage connection board. (See Fig. 13 and 14.)

**NOTE:** For wire runs up to 50 ft, use no. 18 AWG (American Wire Gauge) insulated wire (35°C minimum). For 50 to 75 ft, use no. 16 AWG insulated wire (35°C minimum). For over 75 ft, use no. 14 AWG insulated wire (35°C minimum). All wire larger than no. 18 AWG cannot be directly connected to the thermostat and will require a junction box and splice at the thermostat.

Pass the control wires through the hole provided in the corner post; then feed wires through the raceway built into the corner post to the 24-v barrier located on the left side of the control box. (See Fig. 15). The raceway provides the UL required clearance between high and low-voltage wiring.

**heat anticipator settings**

Set heat anticipator settings at 0.14 amp for first stage and 0.14 for second stage heating, when available.



Table 1—Physical Data 48HJ

BASE UNIT 48HJ	HJE/F/H/K/M/N004	HJD/E/F/G/H/K/L/M/N005	HJD/E/F/G/H/K/L/M/N006	HJD/E/F007
<b>NOMINAL CAPACITY</b>	3	4	5	6
<b>OPERATING WEIGHT (lb)</b>				
Unit	530	540	560	635
Humidi-MiZer™ Adaptive Dehumidification System	15	23	25	29
EconoMiSer IV	50	50	50	50
Roof Curb	115	115	115	115
<b>COMPRESSOR</b>	Scroll			
Quantity	1	1	1	1
Oil (oz)	42	53	50	60
<b>REFRIGERANT TYPE</b>	R-22			
Expansion Device	Acutrol™ Metering Device			
Operating Charge (lb-oz)				
Standard Unit	5-8	10-2	10-0	12- 8
Unit With Humidi-Mizer Adaptive Dehumidification System	12-5	18-8	20-5	23-14
<b>CONDENSER FAN</b>	Propeller			
Quantity...Diameter (in.)	1...22	1...22	1...22	1...22
Nominal Cfm	3500	3500	4100	4100
Motor Hp...Rpm	1/4...825	1/4...825	1/4...1100	1/4...1100
Watts Input (Total)	180	180	320	320
<b>CONDENSER COIL</b>	Enhanced Copper Tubes, Aluminum Lanced Fins			
Rows...Fins/in.	1...17	2...17	2...17	2...17
Total Face Area (sq ft)	14.6	16.5	16.5	21.3
<b>EVAPORATOR COIL</b>	Enhanced Copper Tubes, Aluminum Double-Wavy Fins			
Standard Unit				
Rows...Fins/in.	2...15	2...15	4...15	4...15
Total Face Area (sq ft)	5.5	5.5	5.5	7.3
Unit with Humidi-Mizer Adaptive Dehumidification System				
Rows...Fins/in.	1...17	2...17	2...17	2...17
Total Face Area (sq ft)	3.9	3.9	3.9	5.2
<b>EVAPORATOR FAN</b>	Centrifugal Type, Belt Drive			
Quantity...Size (in.)	1...10 x 10	1...10 x 10	1...10 x 10	1...10 x 10
Nominal Cfm	1200	1600	2000	2400
Maximum Continuous Bhp	Std 1.20	1.20	1.30/2.40*	2.40
	Hi-Static 2.40	2.40	2.90	2.90
Motor RPM	Std 1620	1620	1725	1725
	Hi-Static 1725	1725	1725	1725
Motor Frame Size	Std 48	48	48/56*	56
	Hi-Static 56	56	56	56
Fan Rpm Range	Std 680-1044	770-1185	1035-1460	1119-1585
	Hi-Static 1075-1455	1075-1455	1300-1685	1300-1685
Motor Bearing Type	Ball	Ball	Ball	Ball
Maximum Fan Rpm	2100	2100	2100	2100
Motor Pulley Pitch Diameter A/B (in.)	Std 1.9/2.9	1.9/2.0	2.4/3.4	2.4/3.4
	Hi-Static 2.8/3.8	2.8/3.8	3.4/4.4	3.4/3.4
Nominal Motor Shaft Diameter (in.)	Std 1/2	1/2	5/8	5/8
	Hi-Static 5/8	5/8	5/8	7/8
Fan Pulley Pitch Diameter (in.)	Std 4.5	4.0	4.0	4.0
	Hi-Static 4.5	4.0	4.5	4.5
Belt — Type...Length (in.)	Std 1...A...36	1...A...36	1...4...40	1...A...38
	Hi-Static 1...A...39	1...A...39	1...A...40	1...A...40
Pulley Center Line Distance (in.)	10.0-12.4	10.0-12.4	14.7-15.5	14.7-15.5
Speed Change per Full Turn of Movable Pulley Flange (rpm)	Std 65	70	75	95
	Hi-Static 65	65	60	60
Movable Pulley Maximum Full Turns from Closed Position	Std 5	5	6	5
	Hi-Static 6	6	5	5
Factory Setting — Full Turns Open	Std 3	3	3	3
	Hi-Static 3 1/2	3 1/2	3 1/2	3 1/2
Factory Speed Setting (rpm)	Std 826	936	1248	1305
	Hi-Static 1233	1233	1396	1396
Fan Shaft Diameter at Pulley (in.)	5/8	5/8	5/8	5/8

48HE,HJ

LEGEND

**Bhp** — Brake Horsepower

\*Single phase/three phase.

†Indicates automatic reset.

\*\*60,000 and 72,000 Btuh heat input units have 2 burners. 90,000 and 120,000 Btuh heat input units have 3 burners. 115,000 Btuh heat input units and 150,000 Btuh Heat input units have 3 burners.

††An LP kit is available as an accessory. Kit may be used at elevations as high as 2000 ft. If an LP kit is used with Low NOx units, the Low NOx baffle must be removed and the units will no longer be classified as Low NOx units.

‡ Three-phase standard models have heating inputs as shown. Single-phase standard models have one-stage heating with heating input values as follows:

HJD005-006,HJE004 — 72,000 Btuh

HJE005-006,HJF004 — 115,000 Btuh

HJF005-006 — 150,000 Btuh

\*\*\*California compliant three-phase models.

†††California SCAQMD compliant low NOx models have combustion products that are controlled to 40 nanograms per joule or less.

TABLE 1 — PHYSICAL DATA 48HJ (cont)

BASE UNIT 48HJ	HJE/F/H/K/M/N004	HJD/E/F/G/H/K/L/M/N005	HJD/E/F/G/H/K/L/M/N006	HJD/E/F007
<b>FURNACE SECTION</b>				
Rollout Switch Cutout Temp (F)†	195	195	195	195
Burner Orifice Diameter (in. ...drill size)**				
Natural Gas — Std	HJE .113...33 HJF .113...33 — HJH .113...33 HJK .113...33 — HJM .102...38 HJN .102...38 —	HJD .113...33 HJE .113...33 HJF .129...30 — HJG .113...33 HJH .113...33 HJK .129...30 HJL .102...38 HJM .102...38 HJN .116...32	HJD .113...33 HJE .113...33 HJF .129...30 — HJG .113...33 HJH .113...33 HJK .129...30 HJL .102...38 HJM .102...38 HJN .116...32	HJD .113...33 HJE .113...33 HJF .129...30 — — — — — — — —
Liquid Propane — Alt††	HJE .089...43 HJF .089...43 — HJH .089...43 HJK .089...43 — HJM .082...45 HJN .082...45 —	HJD .089...43 HJE .089...43 HJF .104...37 — HJG .089...45 HJH .089...45 HJK .102...38 HJL .082...45 HJM .082...45 HJN .094...42	HJD .089...43 HJE .089...43 HJF .104...37 — HJG .089...43 HJH .089...43 HJK .104...37 HJL .082...45 HJM .082...45 HJN .094...42	HJD .089...43 HJE .089...43 HJF .104...37 — — — — — — —
Thermostat Heat Anticipator Setting (amps)				
208/230/460/575 v				
First Stage	.14	.14	.14	.14
Second Stage	.14	.14	.14	.14
Gas Input (Btuh)				
First Stage/Second Stage	HJE   50,000/ 72,000 HJF   82,000/115,000 — HJH*** —/ 72,000 HJK*** —/115,000 — HJM††† —/ 60,000 HJN††† —/ 90,000 —	HJD   50,000/ 72,000 HJE   82,000/115,000 HJF   120,000/150,000 HJG*** —/ 72,000 HJH*** —/115,000 HJK*** —/150,000 HJL††† —/ 60,000 HJM††† —/ 90,000 HJN††† —/120,000	HJD   50,000/ 72,000 HJE   82,000/115,000 HJF   120,000/150,000 HJG*** —/ 72,000 HJH*** —/115,000 HJK*** —/150,000 HJL††† —/ 60,000 HJM††† —/ 90,000 HJN††† —/120,000	HJD 50,000/ 72,000 HJE 82,000/115,000 HJF 120,000/150,000 — — — — — —
Efficiency (Steady State) (%)	HJE 82.8 HJF 80 — HJH 82 HJK 80 — HJM 80.2 HJN 81 —	HJD 82.8 HJE 81 HJF 80.4 HJG 82 HJH 81 HJK 80 HJL 80.2 HJM 81 HJN 80.7	HJD 82.8 HJE 81 HJF 80.4 HJG 82 HJH 81 HJK 80 HJL 80.2 HJM 81 HJN 80.7	HJD 82 HJE 81 HJF 80 — — — — — —
Temperature Rise Range	HJE 25-55 HJF 55-85 — HJH 25-55 HJK 55-85 — HJM 20-50 HJN 30-60 —	HJD 25-25 HJE 35-65 HJF 50-80 HJG 25-55 HJH 35-65 HJK 50-80 HJL 20-50 HJM 30-60 HJN 40-70	HJD 25-55 HJE 35-65 HJF 50-80 HJG 25-55 HJH 35-65 HJK 50-80 HJL 20-50 HJM 30-60 HJN 40-70	HJD 25-55 HJE 35-65 HJF 50-80 — — — — — —
Manifold Pressure (in. wg)				
Natural Gas — Std	3.5	3.5	3.5	3.5
Liquid Propane — Alt††	3.5	3.5	3.5	3.5
Maximum Static Pressure (in. wg)	1.0	1.0	1.0	1.0
Field Gas Connection Size (in.)	1/2	1/2	1/2	1/2
<b>HIGH-PRESSURE SWITCH (psig)</b>				
Standard Compressor Internal Relief	450 ± 50			
Cutout	428			
Reset (Auto.)	320			
<b>LOSS-OF-CHARGE SWITCH/LOW-PRESSURE (Liquid Llne) (psig)</b>				
Cutout	7 ± 3			
Reset (Auto.)	22 ± 5			
<b>FREEZE PROTECTION THERMOSTAT</b>				
Opens (F)	30 ± 5			
Closes (F)	45 ± 5			
<b>OUTDOOR-AIR INLET SCREENS</b>	Cleanable. Screen quantity and size varies with option selected.			
<b>RETURN-AIR FILTERS</b>	Throwaway			
Quantity...Size (in.)	2...16 x 25 x 2		4...16 x 16 x 2	

48HE,HJ

**LEGEND**  
**Bhp** — Brake Horsepower  
 \*Single phase/three phase.  
 †Indicates automatic reset.  
 \*\*60,000 and 72,000 Btuh heat input units have 2 burners. 90,000 and 120,000 Btuh heat input units have 3 burners. 115,000 Btuh heat input units and 150,000 Btuh heat input units have 3 burners.  
 ††An LP kit is available as an accessory. Kit may be used at elevations as high as 2000 ft. If an LP kit is used with Low NOx units, the Low NOx baffle must be removed and

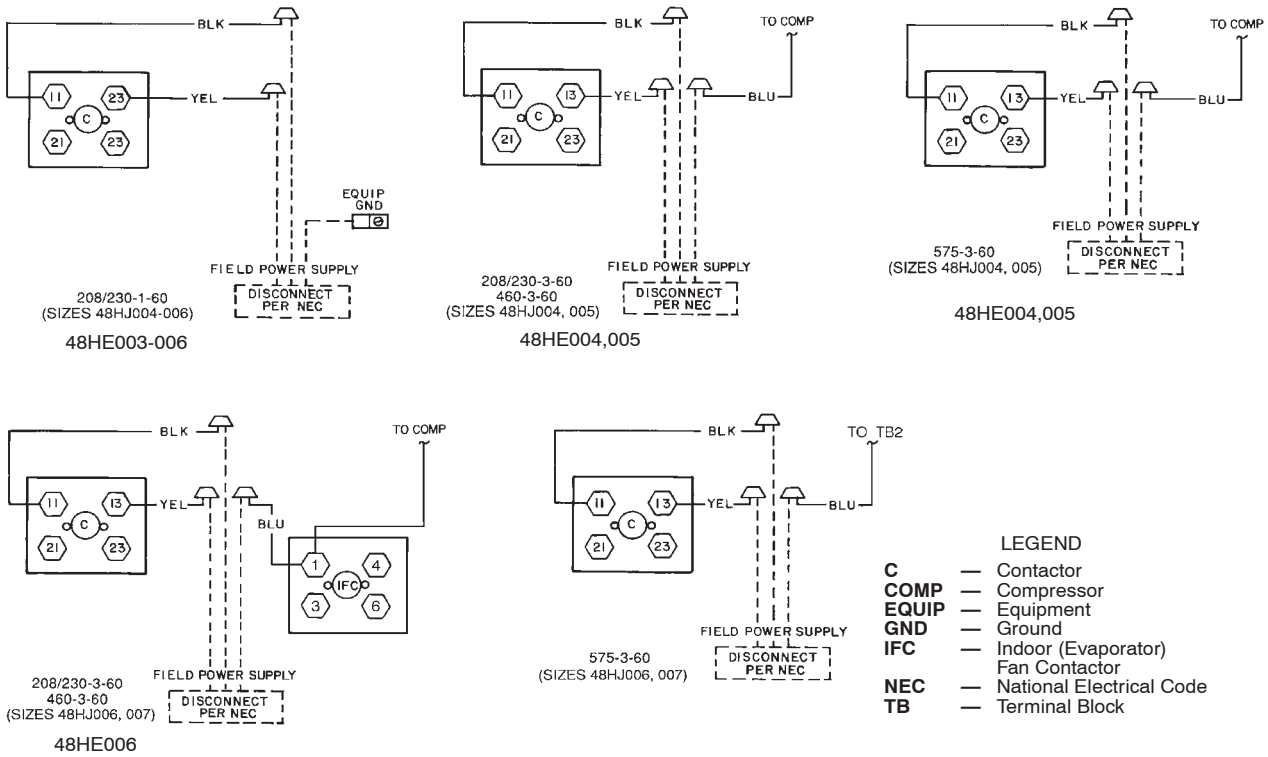
the units will no longer be classified as Low NOx units.  
 †††California compliant three-phase models.  
 †††California SCAQMD compliant low NOx models have combustion products that are controlled to 40 nanograms per joule or less.

Table 2—PHYSICAL DATA 48HE

BASE UNIT 48HE	HD/E/F003	HE/F/H/K/M/N004	H/E/F/G/H/K/L/M/N005	HD/E/F/G/H/K/L/M/N006
<b>NOMINAL CAPACITY</b>	2	3	4	5
<b>OPERATING WEIGHT (lb)</b>				
Unit	530	540	560	635
Humidi-MiZer™ Adaptive Dehumidification System	13	15	23	25
EconoMiZer IV	50	50	50	50
Roof Curb	115	115	115	115
<b>COMPRESSOR</b>			Scroll	
Quantity	1	1	1	1
Oil (oz)	25	42	56	53
<b>REFRIGERANT TYPE</b>			R-22	
Expansion Device			Acutrol™ Metering Device	
Operating Charge (lb-oz)				
Standard Unit	5–3	7–11	8–8	12–11
Unit With Humidi-Mizer Adaptive Dehumidification System	10–2	14–0	14–13	21–0
<b>CONDENSER FAN</b>			Propeller	
Quantity...Diameter (in.)	1...22	1...22	1...22	1...22
Nominal Cfm	3000	3500	3500	4100
Motor Hp...Rpm	1/8...825	1/8...825	1/8...825	1/4...1100
Watts Input (Total)	180	180	180	320
<b>CONDENSER COIL</b>			Enhanced Copper Tubes, Aluminum Lanced Fins	
Rows...Fins/in.	1...17	1...17	2...17	2...17
Total Face Area (sq ft)	14.6	14.6	16.5	16.5
<b>EVAPORATOR COIL</b>			Enhanced Copper Tubes, Aluminum Double-Wavy Fins	
Standard Unit				
Rows...Fins/in.	2...15	2...15	2...15	4...15
Total Face Area (sq ft)	4.2	5.5	5.5	5.5
Unit with Humidi-Mizer Adaptive Dehumidification System				
Rows...Fins/in.	1...17	1...17	2...17	2...17
Total Face Area (sq ft)	3.5	3.9	3.9	3.9
<b>EVAPORATOR FAN</b>			Centrifugal Type, Belt Drive	
Quantity...Size (in.)	1...10 x 10	1...10 x 10	1...10 x 10	1...10 x 10
Nominal Cfm	800	1200	1600	2000
Maximum Continuous Bhp	Std 0.58	1.20	1.20	1.30/2.40*
Motor Frame Size	Hi-Static Std 48	2.40	2.40	2.90
	Hi-Static	56	56	56
Motor Rpm	1620	1620	1620	1725
Fan Rpm Range	Std 400-1000	680-1044	770-1185	1035-1460
	Hi-Static	1075-1455	1075-1455	1300-1685
Motor Bearing Type	Ball	Ball	Ball	Ball
Maximum Fan Rpm	1620	2100	2100	2100
Motor Pulley Pitch Diameter A/B (in.)	Std 2.4/3.2	1.9/2.9	1.9/2.0	2.4/3.4
	Hi-Static	2.8/3.8	2.8/3.8	3.4/4.4
Nominal Motor Shaft Diameter (in.)	Std 5/8	1/2	1/2	5/8
	Hi-Static	7/8	5/8	5/8
Fan Pulley Pitch Diameter (in.)	Std 4.0	4.5	4.0	4.0
	Hi-Static	4.5	4.0	4.5
Belt — Type...Length (in.)	Std 1...A...36	1...A...36	1...A...36	1...4...40
	Hi-Static	1...A...39	1...A...39	1...A...40
Pulley Center Line Distance (in.)	10.0–12.4	10.0-12.4	10.0-12.4	14.7-15.5
Speed Change per Full Turn of Movable Pulley Flange (rpm)	Std 60	65	70	75
	Hi-Static	65	65	60
Movable Pulley Maximum Full Turns from Closed Position	Std 5	5	5	6
	Hi-Static	6	6	5
Factory Setting — Full Turns Open	Std 3	3	3	3
	Hi-Static	3 1/2	3 1/2	3 1/2
Factory Speed Setting (rpm)	Std 756	826	936	1248
	Hi-Static	1233	1233	1396
Fan Shaft Diameter at Pulley (in.)	5/8	5/8	5/8	5/8

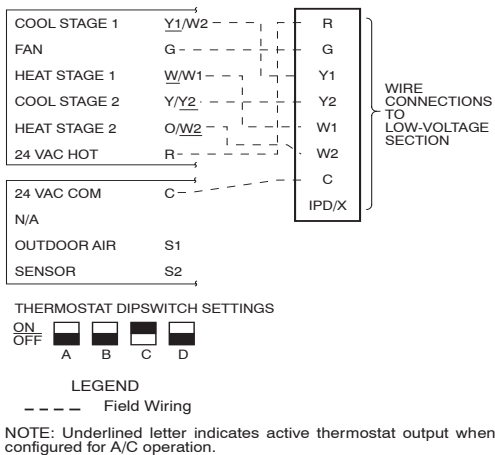
48HE,HJ





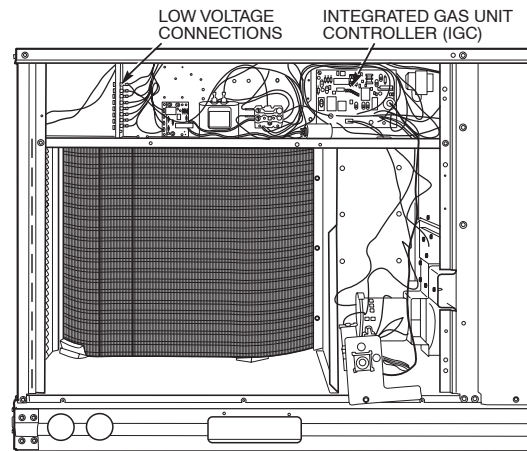
**Fig. 12 – Power Wiring Connections**

C06124



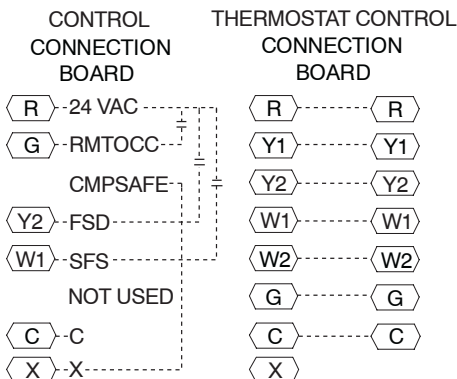
**Fig. 13 – Low-Voltage connections With or Without Economizer or Two-Position Damper**

C06008



**Fig. 15 – Field Control Wiring**

C06125



**Fig. 14 – Low-Voltage Connections (Units with PremierLink™ Controls)**

C06009

Table 3—Electrical Data 48HE

UNIT SIZE	48HE003-006		VOLTAGE RANGE		COMPRESSOR			OFM		COMBUSTION FAN MOTOR		IFM FLA	CONV OUTLET	POWER SUPPLY *		MINIMUM UNIT DISCONNECT SIZE	
	NOMINAL V-PH-Hz	IFM TYPE	Min	Max	QTY	RLA	LRA	QTY	FLA	FLA	FLA			MCA	MOCPS**	FLA	LRA
003 (2 tons)	208/230-1-60	STD	187	254	1	10.9	63	1	0.7	0.6	2.0	NO	16.3	20	15.6	69	
	208/230-1-60	STD	187	254	1	16	88	1	0.7	0.6	4.9	NO	22.3	25	21.2	73	
	208/230-3-60	STD	187	254	1	10.3	77	1	0.7	0.6	4.9	NO	18.5	25	18.3	90	
		HS										NO	19.4	25	19.3	95	
004 (3 tons)	460-3-60	STD	414	508	1	5.1	39	1	0.4	0.3	2.2	NO	9.0	15	8.9	46	
		HS	NO	9.4	15	9.3	60										
	575-3-60	STD	518	632	1	4.2	31	1	0.4	0.3†	2.0	NO	9.4	15	9.3	60	
		HS										NO	12.1	15	11.8	63	
005 (4 tons)	208/230-1-60	STD	197	254	1	21	115	1	1.5	0.6	4.9	NO	32.7	40	31.5	130	
		HS	NO	38.7	45	37.0	135										
	208/230-3-60	STD	187	254	1	14.1	95	1	1.5	0.6	4.9	NO	24.0	30	23.6	110	
		HS										NO	24.9	30	24.6	140	
006 (5 tons)	460-3-60	STD	414	508	1	7.1	45	1	0.8	0.3	2.2	NO	11.9	15	11.6	53	
		HS	NO	12.3	15	12.1	67										
	575-3-60	STD	518	632	1	6.1	38	1	0.6	0.3†	2.0	NO	10.1	15	9.9	44	
		HS										NO	10.2	15	11.9	46	
208/230-1-60	STD	187	254	1	25	150	1	1.5	0.6	6.6	NO	10.3	15	12.0	52		
											HS	NO	10.3	15	10.1	56	
	208/230-3-60	STD	187	254	1	17.3	123	1	1.5	0.6	5.8	NO	39.4	50	38.1	187	
		HS										NO	45.4	60	43.6	191	
460-3-60	STD	414	508	1	8.4	70	1	0.8	0.3†	3.4	NO	28.9	35	28.3	168		
											HS	NO	34.9	40	33.8	173	
	575-3-60	STD	518	632	1	7.1	53	1	0.6	0.3†	2.8	NO	30.6	35	30.2	187	
		HS										NO	36.6	40	35.8	192	

FLA – Full Load Amps  
HACR – Heating, Air Conditioning and Refrigeration  
IFM – Indoor (Evaporator) Fan Motor  
LRA – Locked Rotor Amps  
MCA – Minimum Circuit Amps  
MOCPS – Maximum Overcurrent Protection  
NEC – National Electrical Code  
OFM – Outdoor (Condenser) Fan Motor  
RLA – Rated Load Amps

NOTES:  
\* The values listed in this table do not include power exhaust. See power exhaust table for power exhaust requirements.  
\*\* Fuse or HACR breaker  
† 460v motor

Table 4—Electrical Data 48HJ

UNIT SIZE	48HJ004-014		VOLTAGE RANGE		COMPRESSOR (each)			COMBUSTION FAN MOTOR			IFM FLA	CONV. OUTLET	POWER SUPPLY *		MINIMUM UNIT DISCONNECT SIZE	
	NOMINAL V-PH-Hz	IFM TYPE	Min	Max	QTY	RLA	LRA	QTY	FLA (each)	FLA			MCA	MOCPS**	FLA	LRA
004 (3 Tons)	208/230-1-60	STD	187	254	1	16	88	1	0.7	0.6	4.9	NO	25.6	30	25	101
		HS	187	254	1	10.3	77	1	0.7	0.6	4.9	NO	31.6	35	30	106
	460-3-60	STD	414	508	1	5.1	39	1	0.4	0.3	2.2	YES	18.5	25	18	90
		HS	414	508	1	5.1	39	1	0.4	0.3	2.2	YES	24.5	30	24	95
	575-3-60	STD	518	632	1	4.2	31	1	0.4	0.3†	1.9	YES	19.4	25	19	120
		Humidifier	518	632	1	4.2	31	1	0.4	0.3†	1.9	YES	25.4	30	25	124
005 (4 Tons)	208/230-1-60	STD	187	254	1	23.7	126	1	0.7	0.6	4.9	NO	9.0	15	9	46
		HS	187	254	1	13.5	93	1	0.7	0.6	4.9	NO	11.7	15	11	48
	460-3-60	STD	414	508	1	6.4	46.5	1	0.4	0.3	2.6	YES	9.4	15	9	60
		HS	414	508	1	6.4	46.5	1	0.4	0.3	2.6	YES	12.1	15	12	63
	575-3-60	STD	518	632	1	6.4	40	1	0.4	0.3†	2.0	YES	7.6	10	7	36
		Humidifier	518	632	1	6.4	40	1	0.4	0.3†	2.0	YES	9.7	15	9	38
006 (5 Tons)	208/230-1-60	STD	187	254	1	28.8	169	1	1.5	0.6	6.6	NO	7.7	10	8	44
		HS	187	254	1	17.3	123	1	1.5	0.6	6.6	NO	9.8	15	10	44
	460-3-60	STD	414	508	1	9	62	1	0.8	0.3	3.4	YES	10.4	15	10	52
		HS	414	508	1	9	62	1	0.8	0.3	3.4	YES	12.6	15	12	53
	575-3-60	STD	518	632	1	7.1	50	1	0.6	0.3†	2.6†	YES	11.0	15	11	61
		Humidifier	518	632	1	7.1	50	1	0.6	0.3†	2.6†	YES	13.2	15	13	63
007 (6 Tons)	208/230-1-60	STD	187	254	1	28.8	169	1	1.5	0.6	6.6	NO	14.1	20	14	84
		HS	187	254	1	17.3	123	1	1.5	0.6	6.6	NO	17.4	20	17	87
	460-3-60	STD	414	508	1	9	62	1	0.8	0.3	3.4	YES	15.5	20	15	94
		HS	414	508	1	9	62	1	0.8	0.3	3.4	YES	18.2	20	18	96
	575-3-60	STD	518	632	1	7.1	50	1	0.6	0.3†	2.0	YES	11.5	15	11	63
		Humidifier	518	632	1	7.1	50	1	0.6	0.3†	2.0	YES	13.6	15	13	64
008 (6 Tons)	208/230-1-60	STD	187	254	1	20.5	156	1	1.4	0.6	5.8	NO	12.3	15	12	72
		HS	187	254	1	20.5	156	1	1.4	0.6	5.8	NO	14.4	20	14	73
	460-3-60	STD	414	508	1	9.6	75	1	0.6	0.3	2.6	YES	12.2	15	12	76
		HS	414	508	1	9.6	75	1	0.6	0.3	2.6	YES	14.4	20	14	77
	575-3-60	STD	518	632	1	7.7	56	1	0.8	0.3†	2.8	YES	14.4	20	14	73
		Humidifier	518	632	1	7.7	56	1	0.8	0.3†	2.8	YES	17.4	20	17	87

Table 4—Electrical Data 48HJ (cont)

Tons	208/230-3-60	STD	187	254	2	12.4	88	2	1.4	0.6	7.5	NO	38.2	45	40	242	
																	HS
008 (71/2 Tons)	460-3-60	STD	414	508	2	6.4	44	2	0.7	0.3	3.4	NO	19.2	25	20	121	
		HS															
	575-3-60	STD	518	632	2	4.8	34	2	0.6	0.3†	2.8	YES	14.6	20	15	95	
		HS															
		Humid/Miser															
		Humid/Miser															
009 (81/2 Tons)	208/230-3-60	STD	187	254	2	13.1	105	2	1.4	0.6	7.5	NO	40.2	45	42	276	
		HS															
	460-3-60	STD	414	508	2	7.4	55	2	0.7	0.3	3.4	YES	24.2	30	25	145	
		HS															
	575-3-60	STD	518	632	2	6.4	44	2	0.6	0.3†	2.8	YES	18.2	20	19	115	
		HS															
		Humid/Miser															
		Humid/Miser															
	012 (10 Tons)	208/230-3-60	STD	187	254	2	17.6	125	2	1.4	0.6	10.6	NO	53.0	60	56	341
			HS														
		460-3-60	STD	414	508	2	8.3	62.5	2	0.7	0.3	4.8	YES	27.6	30	29	173
			HS														
575-3-60		STD	518	632	2	6.3	50	2	0.6	0.3†	3.3	YES	19.1	25	20	136	
		HS															
		Humid/Miser															
		Humid/Miser															
014 (121/2 Tons)		208/230-3-60	STD	187	254	2	19	156	2	1.4	0.6	15.0	NO	60.6	70	64	426
			HS														
		460-3-60	STD	414	508	2	9	75	2	0.7	0.3	7.4	YES	29.1	35	31	207
			HS														
	575-3-60	STD	518	632	2	7.4	54	2	0.6	0.3†	5.6	YES	23.5	30	25	154	
		HS															
		Humid/Miser															
		Humid/Miser															

FLA – Full Load Amps  
HACR – Heating, Air Conditioning and Refrigeration  
IFM – Indoor (Evaporator) Fan Motor  
LRA – Locked Rotor Amps  
MCA – Minimum Circuit Amps  
MOCP – Maximum Overcurrent Protection  
NEC – National Electrical Code  
OFM – Outdoor (Condenser) Fan Motor  
RLA – Rated Load Amps

NOTES:  
\* The values listed in this table do not include power exhaust. See power exhaust table for power exhaust requirements.  
\*\* Fuse or HACR breaker  
† 460v motor



## Step 8 —Adjust Factory-Installed Options

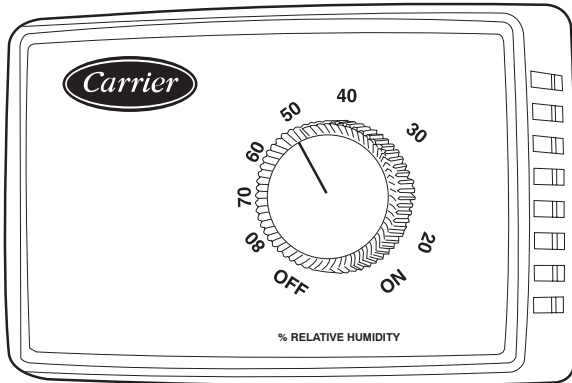
### cobra™ energy recovery units

Please refer to the supplement provided for information on installing and operating the factory optional COBRA Energy Recovery Units. These units are equipped with a factory-installed energy recovery unit and have different installation and operation procedures than the standard unit.

### HUMIDI-MIZER™ ADAPTIVE DEHUMIDIFICATION SYSTEM

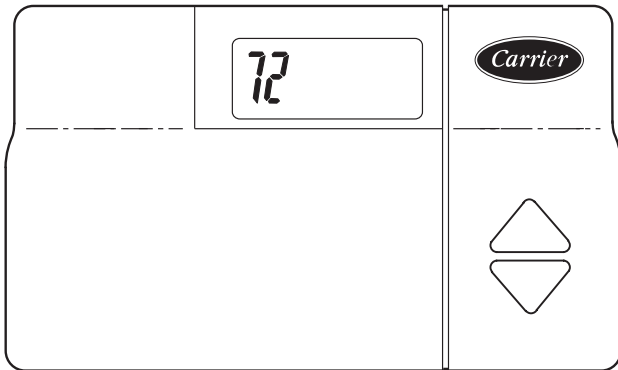
Humidi-MiZer system operation can be controlled by field installation of a Carrier-approved humidistat. (See Fig. 16.)

**NOTE:** A light commercial Thermidistat™ device (Fig. 17) can be used instead of the humidistat if desired. The Thermidistat device includes a thermostat and a humidistat. The humidistat is normally used in applications where a temperature sensor is already provided (units with PremierLink™ control).



C06126

**Fig. 16 – Accessory Field-Installed Humidistat**



C06127

**Fig. 17 – Light Commercial Thermidistat Device**

To install the humidistat:

1. Route humidistat cable through hole provided in unit control box.
2. Some models may be equipped with a raceway built into the corner post located on the left side of control box (See Fig. 15). This raceway provides the required clearance between high-voltage and low voltage wiring. For models without a raceway, ensure to provide the NEC required clearance between the high-voltage and low-voltage wiring.

3. Use a wire nut to connect humidistat cable into low-voltage wiring as shown in Fig. 18.

To install Thermidistat device:

1. Route Thermidistat cable through hole provided in unit control box.
2. Some models may be equipped with a raceway built into the corner post located on the left side of control box (See Fig. 15). This raceway provides the required clearance between high-voltage and low voltage wiring. For models without a raceway, ensure to provide the NEC required clearance between the high-voltage and low-voltage wiring.
3. A field-supplied relay must be installed between the Thermidistat and the Humidi-MiZer circuit (recommended relay: HN612KK324). (See Fig. 19.) The relay coil is connected between the DEHUM output and C (common) of the unit. The relay controls the Humidi-MiZer solenoid valve and must be wired between the Humidi-MiZer fuse and the low-pressure switch. Refer to the installation instructions included with the Carrier Light Commercial Thermidistat device for more information.

### manual outdoor damper

The outdoor-air hood and screen are attached to the basepan at the bottom of the unit for shipping.

**Assembly:**

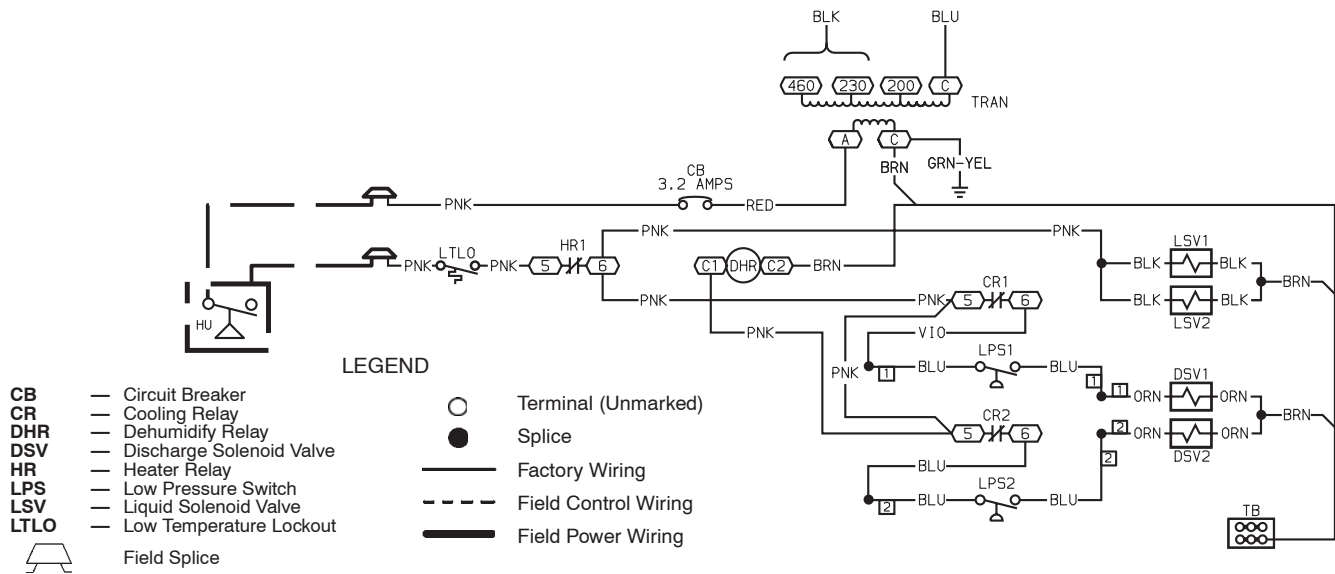
1. Determine quantity of ventilation required for building. Record amount for use in Step 8.
2. Remove and save outdoor air opening panel and screws. (See Fig. 20.)
3. Remove evaporator coil access panel. Separate hood and screen from basepan by removing the 4 screws securing them. Save all screws.
4. Replace evaporator coil access panel.
5. Place hood on front of outdoor air opening panel. See Fig. 21 for hood details. Secure top of hood with the 4 screws removed in Step 3. (See Fig. 22.)
6. Remove and save 6 screws (3 on each side) from sides of the manual outdoor-air damper.
7. Align screw holes on hood with screw holes on side of manual outdoor-air damper. (See Fig. 21 and 22.) Secure hood with 6 screws from Step 6.
8. Adjust minimum position setting of the damper blade by adjusting the manual outdoor-air adjustment screws on the front of the damper blade. (See Fig. 20.) Slide blade vertically until it is in the appropriate position determined by Fig. 23. Tighten screws.
9. Remove and save screws currently on sides of hood. Insert screen. Secure screen to hood using the screws. (See Fig. 22.)

### convenience outlet

An optional convenience outlet provides power for rooftop use. For maintenance personnel safety, the convenience outlet power is off when the unit disconnect is off. Adjacent unit outlets may be used for service tools.

### novar controls

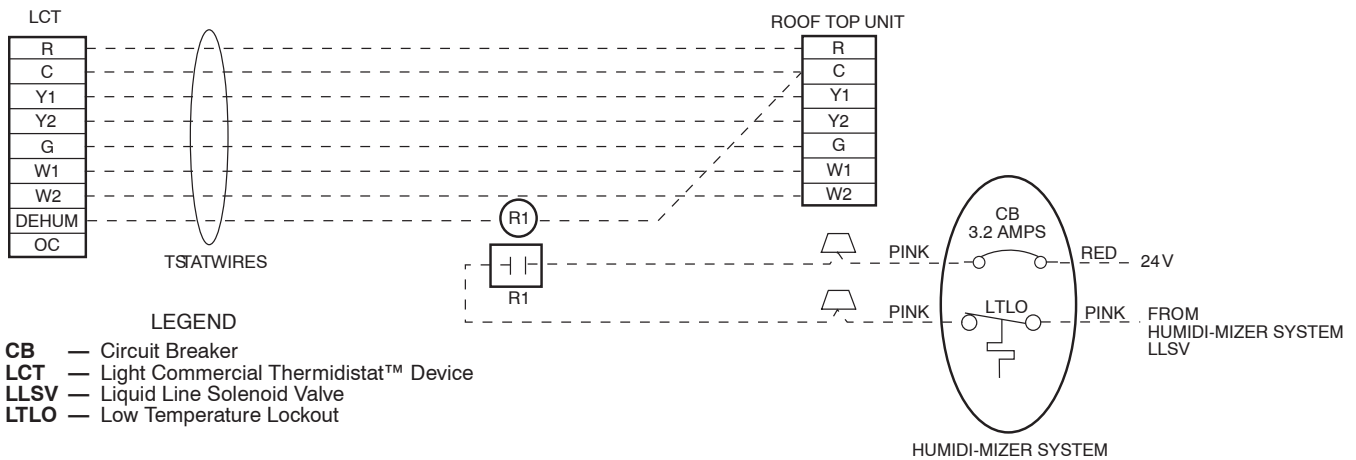
Optional Novar controls (ETM 3051) are available for replacement or new construction jobs.



- LEGEND**
- CB — Circuit Breaker
  - CR — Cooling Relay
  - DHR — Dehumidify Relay
  - DSV — Discharge Solenoid Valve
  - HR — Heater Relay
  - LPS — Low Pressure Switch
  - LSV — Liquid Solenoid Valve
  - LTLO — Low Temperature Lockout
  - Field Splice
  - Terminal (Unmarked)
  - Splice
  - Factory Wiring
  - - - Field Control Wiring
  - Field Power Wiring

**Fig. 18 – Typical Humidi-MiZer™ Adaptive Dehumidification System Humidistat Wiring (208/230-V Unit Shown)**

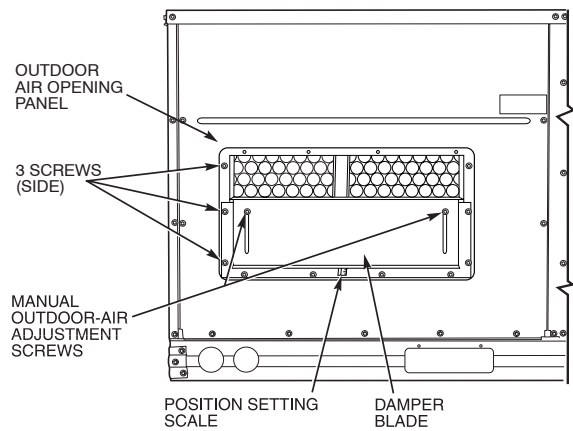
C06128



- LEGEND**
- CB — Circuit Breaker
  - LCT — Light Commercial Thermidistat™ Device
  - LLSV — Liquid Line Solenoid Valve
  - LTLO — Low Temperature Lockout

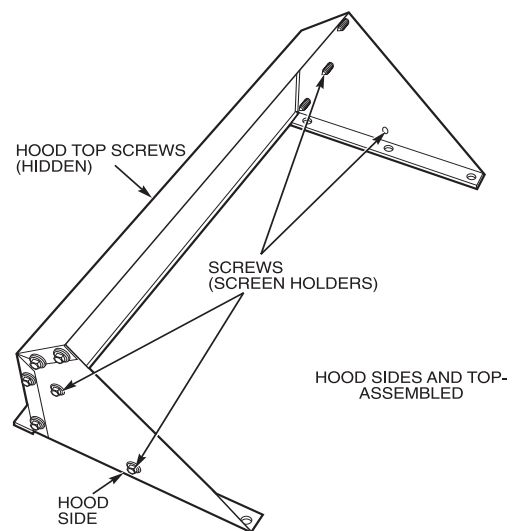
**Fig. 19 – Typical Rooftop Unit with Humidi-MiZer Adaptive Dehumidification System with Thermidistat Device**

C06129



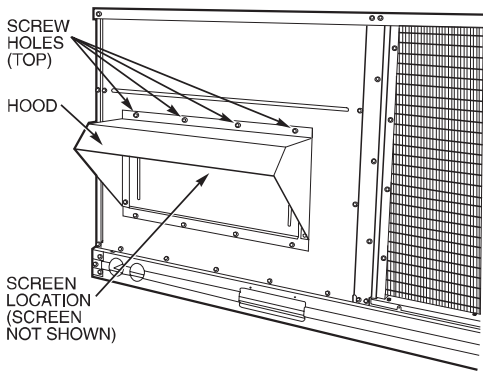
**Fig. 20 – Damper Panel with Manual Outdoor-Air Damper Installed**

C06130



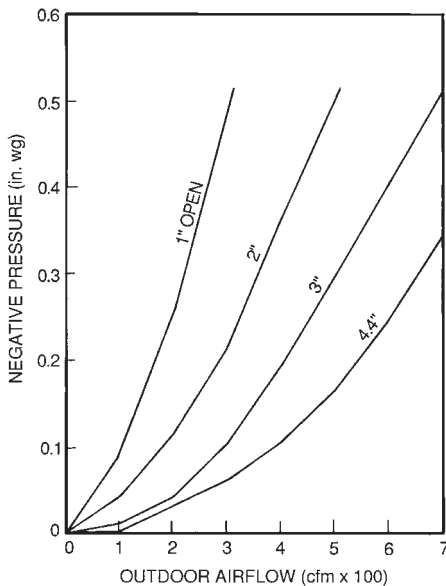
**Fig. 21 – Outdoor-Air Hood Details**

C06013



**Fig. 22 – Outdoor-Air Damper With Hood Attached**

C06131



**Fig. 23 – Outdoor-Air Damper Position Setting**

C06132

**premierlink™ control**

The PremierLink controller is compatible with Carrier Comfort Network® (CCN) devices. This control is designed to allow users the access and ability to change factory-defined settings, thus expanding the function of the standard unit control board. Carrier’s diagnostic standard tier display tools such as Navigator™ or Scrolling Marquee can be used with the PremierLink controller.

The PremierLink controller (see Fig. 24 and 25) requires the use of a Carrier electronic thermostat or a CCN connection for time broadcast to initiate its internal timeclock. This is necessary for broadcast of time of day functions (occupied/unoccupied). No sensors are supplied with the field-mounted PremierLink control. The factory-installed PremierLink control includes only the supply-air temperature (SAT) sensor and the outdoor air temperature (OAT) sensor as standard. An indoor air quality (CO2) sensor can be added as an option. Refer to Table 5 for sensor usage. Refer to Fig. 26 for PremierLink controller wiring. The PremierLink control may be mounted in the control panel or an area below the control panel.

**NOTE:** PremierLink controller versions 1.3 and later are shipped in Sensor mode. If used with a thermostat, the PremierLink controller must be configured to Thermostat mode.

**Install the Supply Air Temperature (SAT) Sensor**

When the unit is supplied with a factory-mounted PremierLink control, the supply-air temperature (SAT) sensor (33ZCSENSAT) is factory-supplied and wired. The wiring is routed from the PremierLink control over the control box, through a grommet, into the fan section, down along the back side of the fan, and along the fan deck over to the supply-air opening.

The SAT probe is wire-tied to the supply-air opening (on the horizontal opening end) in its shipping position. Remove the sensor for installation. Re-position the sensor in the flange of the supply-air opening or in the supply air duct (as required by local codes). Drill or punch a 1/2-in. hole in the flange or duct. Use two field-supplied, self-drilling screws to secure the sensor probe in a horizontal orientation.

**NOTE:** The sensor must be mounted in the discharge airstream downstream of the cooling coil and any heating devices. Be sure the probe tip does not come in contact with any of the unit or heat surfaces.

**Outdoor Air Temperature Sensor (OAT)**

When the unit is supplied with a factory-mounted PremierLink control and economizer, the outdoor-air temperature sensor (OAT) is factory-supplied and wired.

**Install the Indoor Air Quality (CO2) Sensor**

Mount the optional indoor air quality (CO2) sensor according to manufacturer specifications.

A separate field-supplied transformer must be used to power the CO2 sensor.

Wire the CO2 sensor to the COM and IAQI terminals of J5 on the PremierLink controller. Refer to the PremierLink Installation, Start-up, and Configuration Instructions for detailed wiring and configuration information.

**Enthalpy Sensors and Control**

The enthalpy control (HH57AC077) is supplied as a field-installed accessory to be used with the EconoMi\$er2 damper control option. The outdoor air enthalpy sensor is part of the enthalpy control. The separate field-installed accessory return air enthalpy sensor (HH57AC078) is required for differential enthalpy control.

**NOTE:** The enthalpy control must be set to the “D” setting for differential enthalpy control to work properly.

The enthalpy control receives the indoor and return enthalpy from the outdoor and return air enthalpy sensors and provides a dry contact switch input to the PremierLink controller. Locate the controller in place of an existing economizer controller or near the actuator. The mounting plate may not be needed if existing bracket is used.

A closed contact indicates that outside air is preferred to the return air. An open contact indicates that the economizer should remain at minimum position.

**Outdoor Air Enthalpy Sensor/Enthalpy Controller (HH57AC077)**

To wire the outdoor air enthalpy sensor, perform the following (See Fig. 27 and 28):

**NOTE:** The outdoor air sensor can be removed from the back of the enthalpy controller and mounted remotely.

48HE\_HJ

Table 5—PremierLink™ Sensor Usage

APPLICATION	OUTDOOR AIR TEMPERATURE SENSOR	RETURN AIR TEMPERATURE SENSOR	OUTDOOR AIR ENTHALPY SENSOR	RETURN AIR ENTHALPY SENSOR
Differential Dry Bulb Temperature with PremierLink* (PremierLink requires 4-20 mA Actuator)	Included – CRTEMPSN001A00	Required – 33ZCT55SPT or Equivalent	—	—
Single Enthalpy with PremierLink* (PremierLink requires 4-20 mA Actuator)	Included – Not Used	—	Required – HH57AC077 or Equivalent	—
Differential Enthalpy with PremierLink* (PremierLink requires 4-20 mA Actuator)	Included – Not Used	—	Required – HH57AC077 or Equivalent	Required – HH57AC078 or Equivalent

\*PremierLink control requires Supply Air Temperature sensor 33ZCSENSAT and Outdoor Air Temperature sensor CRTEMPSN001A00 — Included with factory-installed PremierLink control; field-supplied and field-installed with field-installed PremierLink control.

NOTES:

- CO<sub>2</sub> Sensors (Optional):
  - 33ZCSENSCO2 — Room sensor (adjustable). Aspirator box is required for duct mounting of the sensor.
  - 33ZCASPCO2 — Aspirator box used for duct-mounted CO<sub>2</sub> room sensor.
  - 33ZCT55CO2 — Space temperature and CO<sub>2</sub> room sensor with override.
  - 33ZCT56CO2 — Space temperature and CO<sub>2</sub> room sensor with override and set point.
- All units include the following Standard Sensors:
  - Outdoor-Air Sensor — 50HJ540569 — Opens at 67°F, closes at 52°F, not adjustable.
  - Mixed-Air Sensor — HH97AZ001 — (PremierLink control requires Supply Air Temperature sensor 33ZCSENSAT and Outdoor Air Temperature Sensor CRTEMPSN001A00)
  - Compressor Lockout Sensor — 50HJ540570 — Opens at 35°F, closes at 50°F.

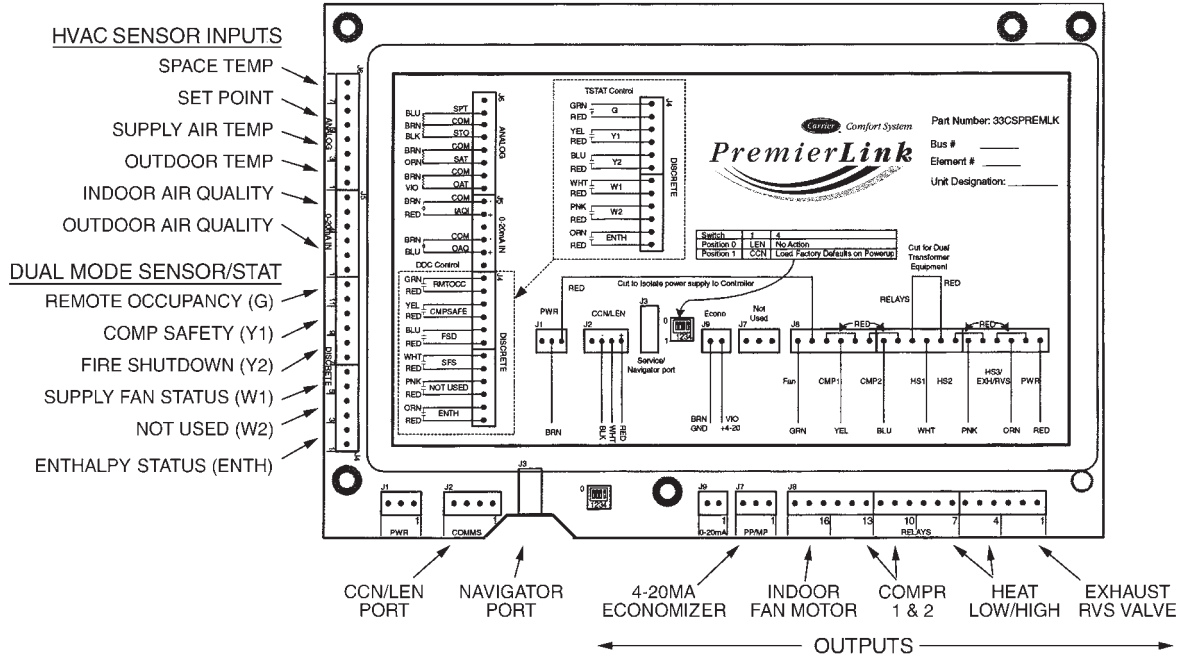


Fig. 24 – PremierLink Controller

C06016

48HE,HJ

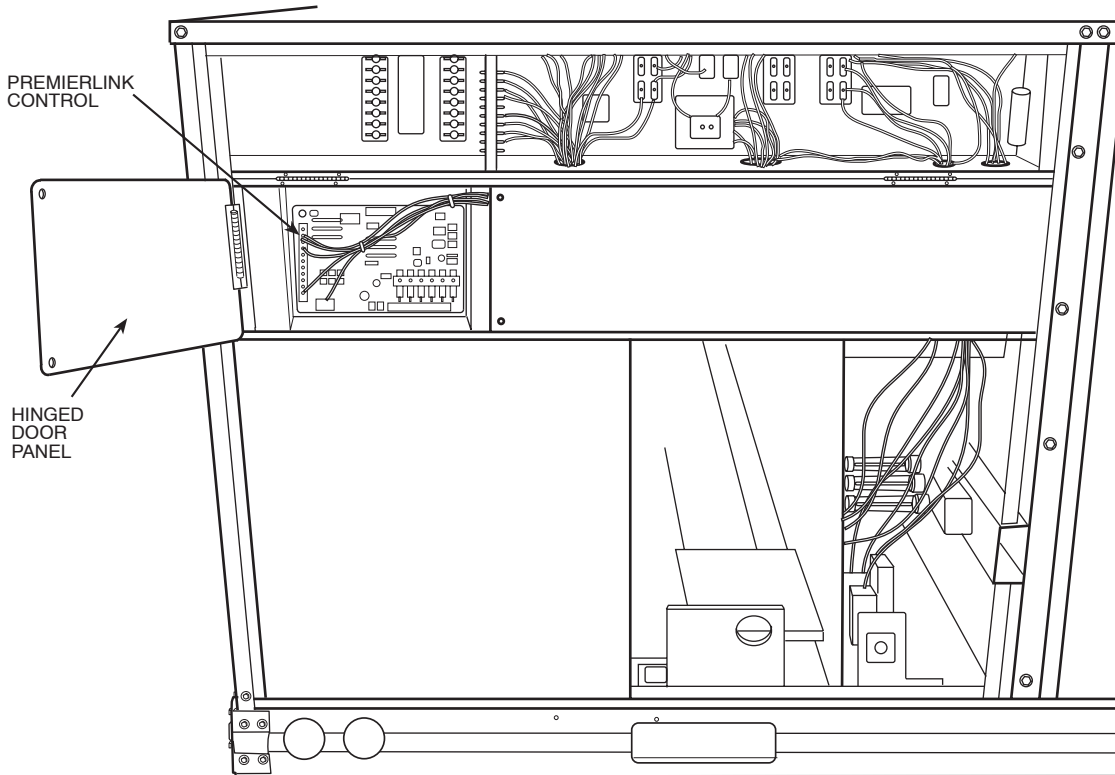


Fig. 25 – PremierLink™ Controller (Installed)

C06017

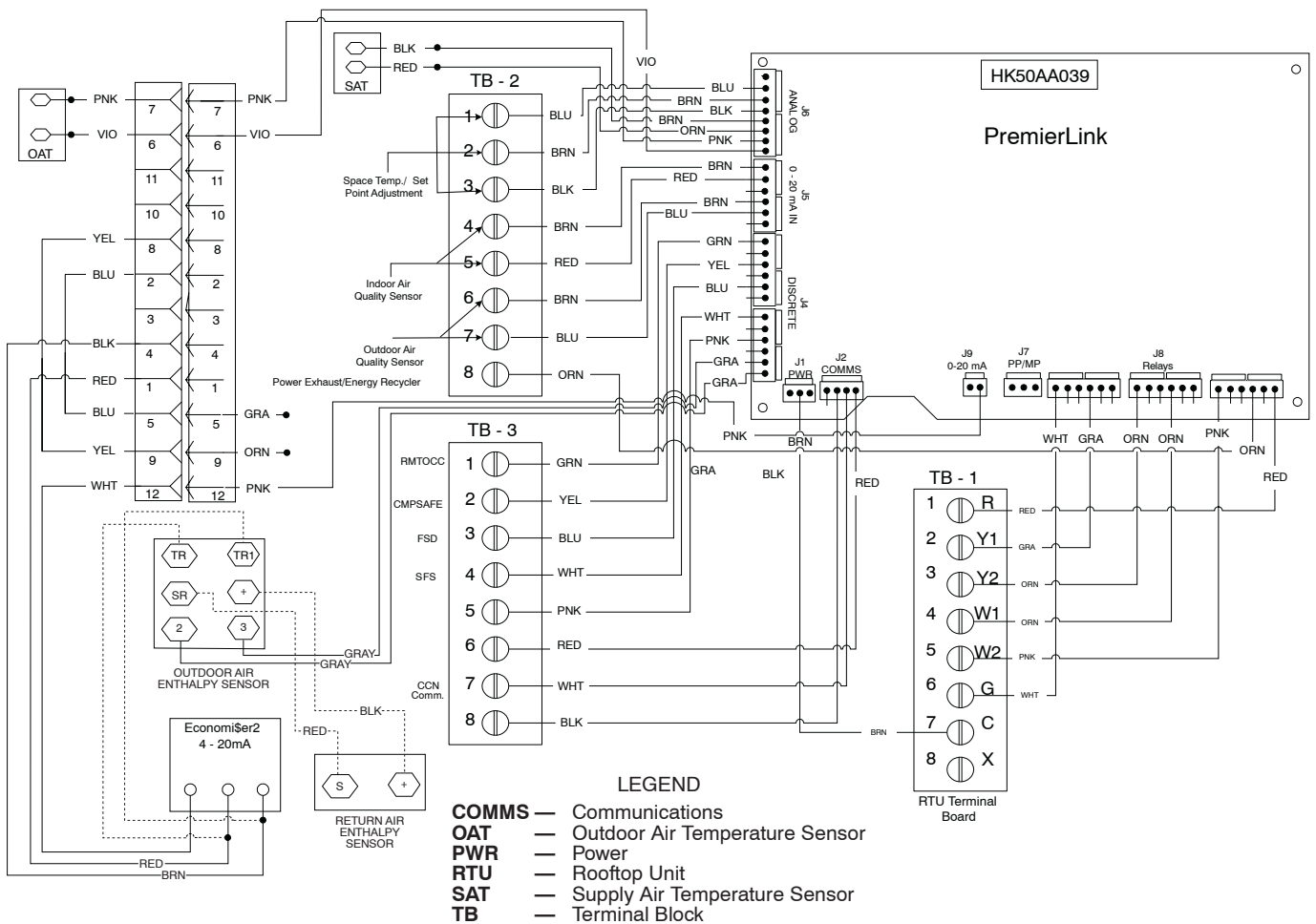


Fig. 26 – Typical PremierLink Control Wiring

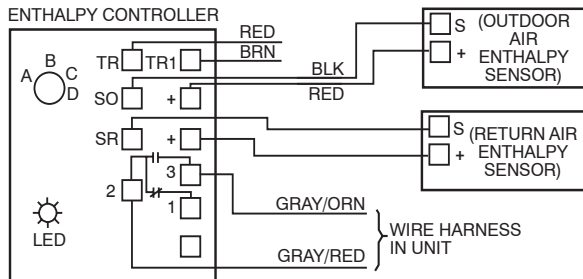
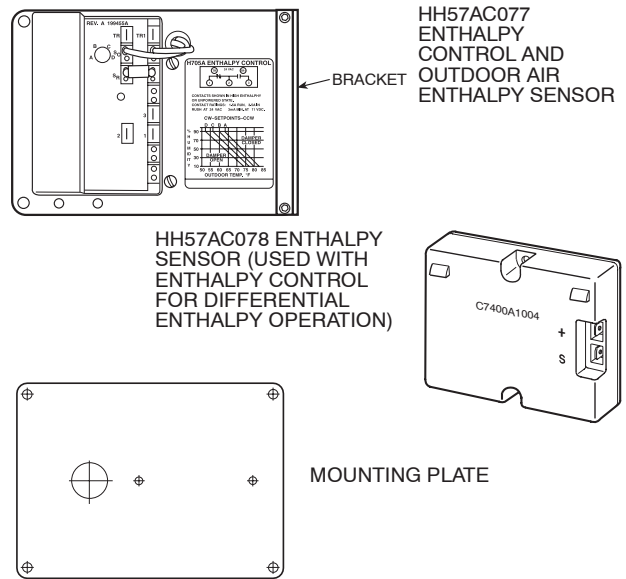
C06018

1. Use a 4-conductor, 18 or 20 AWG cable to connect the enthalpy control to the PremierLink™ controller and power transformer.
2. Connect the following 4 wires from the wire harness located in rooftop unit to the enthalpy controller:
  - a. Connect the BRN wire to the 24 vac terminal (TR1) on enthalpy control and to pin 1 on 12-pin harness.
  - b. Connect the RED wire to the 24 vac GND terminal (TR) on enthalpy sensor and to pin 4 on 12-pin harness.
  - c. Connect the GRAY/ORN wire to J4-2 on PremierLink controller and to terminal (3) on enthalpy sensor.
  - d. Connect the GRAY/RED wire to J4-1 on PremierLink controller and to terminal (2) on enthalpy sensor.

**NOTE:** If installing in a Carrier rooftop, use the two gray wires provided from the control section to the economizer to connect PremierLink controller to terminals 2 and 3 on enthalpy sensor.

**Return Air Enthalpy Sensor**

Mount the return-air enthalpy sensor (HH57AC078) in the return-air duct. The return air sensor is wired to the enthalpy controller (HH57AC077). The outdoor enthalpy changeover set point is set at the controller.



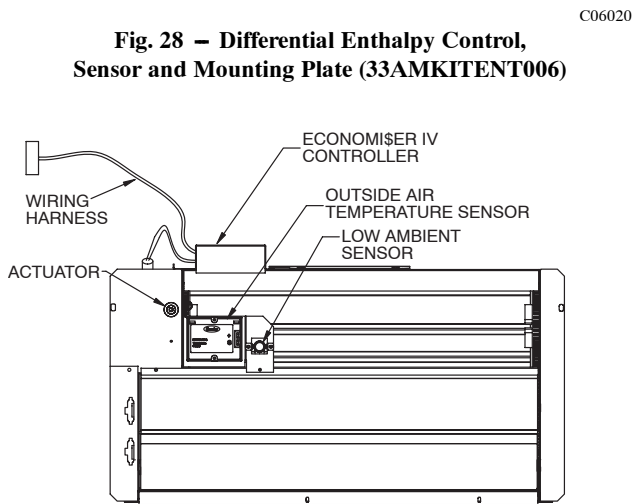
- NOTES:**
1. Remove factory-installed jumper across SR and + before connecting wires from return air sensor.
  2. Switches shown in high outdoor air enthalpy state. Terminals 2 and 3 close on low outdoor air enthalpy relative to indoor air enthalpy.
  3. Remove sensor mounted on back of control and locate in outside air-stream.

**Fig. 27 – Outdoor and Return Air Sensor Wiring Connections for Differential Enthalpy Control**

C06019

To wire the return air enthalpy sensor, perform the following (See Fig. 27):

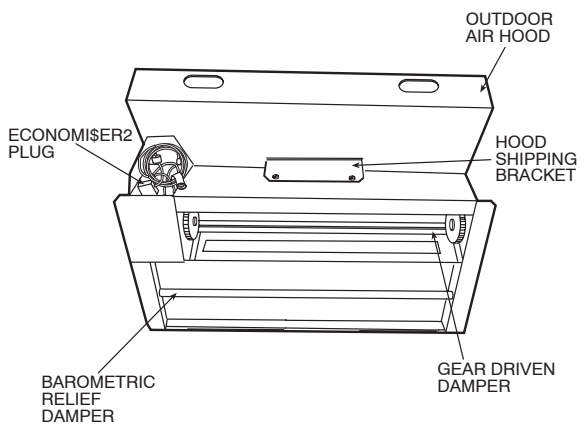
1. Use a 2-conductor, 18 or 20 AWG, twisted pair cable to connect the return air enthalpy sensor to the enthalpy controller.
2. At the enthalpy control remove the factory-installed resistor from the (SR) and (+) terminals.
3. Connect the field-supplied RED wire to (+) spade connector on the return air enthalpy sensor and the (SR+) terminal on the enthalpy controller. Connect the BLK wire to (S) spade connector on the return air enthalpy sensor and the (SR) terminal on the enthalpy controller.



C06020

**Fig. 29 – EconoMiSer IV Component Locations**

C06021



C06022

**Fig. 30 – EconoMiSer2 Component Locations**

**optional economiser IV and economiser2**

See Fig. 29 for EconoMiSer IV component locations. See Fig. 30 for EconoMiSer2 component locations.

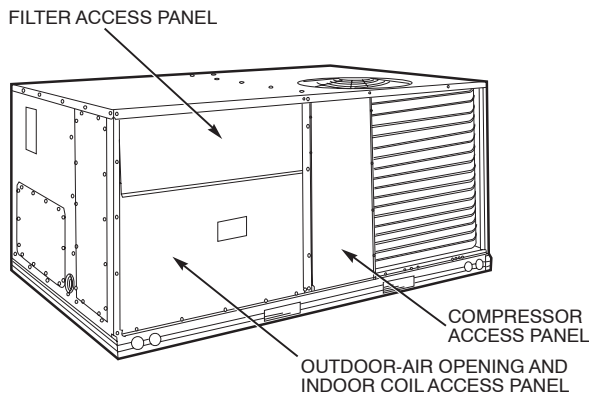
**NOTE:** These instructions are for installing the optional EconoMi\$er IV and EconoMi\$er2 only. Refer to the accessory EconoMi\$er IV or EconoMi\$er2 installation instructions when field installing an EconoMi\$er IV or EconoMi\$er2 accessory.

1. To remove the existing unit filter access panel, raise the panel and swing the bottom outward. The panel is now disengaged from the track and can be removed. (See Fig. 31.)
2. The box with the economizer hood components is shipped in the compartment behind the economizer. The EconoMi\$er IV controller is mounted on top of the EconoMi\$er IV in the position shown in Fig. 26. The optional EconoMi\$er2 with 4 to 20 mA actuator signal control does not include the EconoMi\$er IV controller. To remove the component box from its shipping position, remove the screw holding the hood box bracket to the top of the economizer. Slide the hood box out of the unit. (See Fig. 32.)

**IMPORTANT:** If the power exhaust accessory is to be installed on the unit, the hood shipped with the unit will not be used and must be discarded. Save the aluminum filter for use in the power exhaust hood assembly.

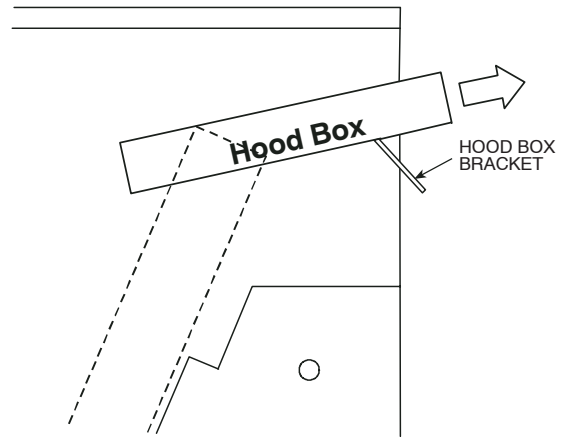
3. The indoor coil access panel will be used as the top of the hood. Remove the screws along the sides and bottom of the indoor coil access panel. (See Fig. 33.)
4. Swing out indoor coil access panel and insert the hood sides under the panel (hood top). Use the screws provided to attach the hood sides to the hood top. Use screws provided to attach the hood sides to the unit. (See Fig. 34.)
5. Remove the shipping tape holding the economizer barometric relief damper in place.
6. Insert the hood divider between the hood sides. (See Fig. 34 and 35.) Secure hood divider with 2 screws on each hood side. The hood divider is also used as the bottom filter rack for the aluminum filter.
7. Open the filter clips which are located underneath the hood top. Insert the aluminum filter into the bottom filter rack (hood divider). Push the filter into position past the open filter clips. Close the filter clips to lock the filter into place. (See Fig. 35.)
8. Caulk the ends of the joint between the unit top panel and the hood top. (See Fig. 33.)
9. Replace the filter access panel.
10. Install all EconoMi\$er IV accessories. EconoMi\$er IV wiring is shown in Fig. 36. EconoMi\$er2 wiring is shown in Fig. 37.

Barometric flow capacity is shown in Fig. 38. Outdoor air leakage is shown in Fig. 39. Return air pressure drop is shown in Fig. 40.



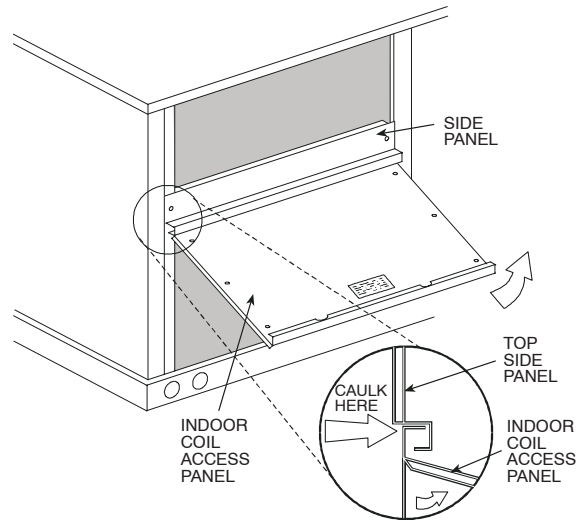
**Fig. 31 – Typical Access Panel Locations**

C06023



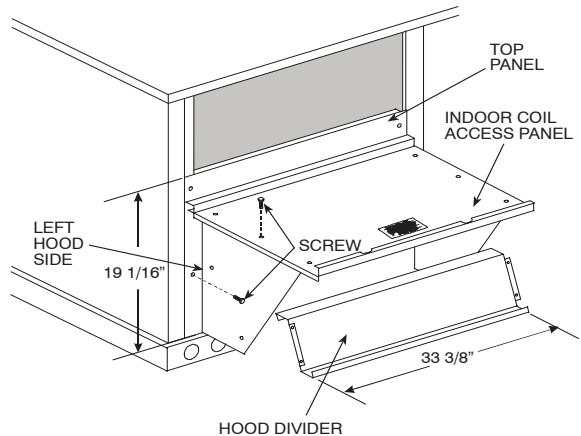
**Fig. 32 – Hood Box Removal**

C06024



**Fig. 33 – Indoor Coil Access Panel Relocation**

C06025



**Fig. 34 – Outdoor-Air Hood Construction**

C06026

**ECONOMISER IV STANDARD SENSORS**

**Outdoor Air Temperature (OAT) Sensor**

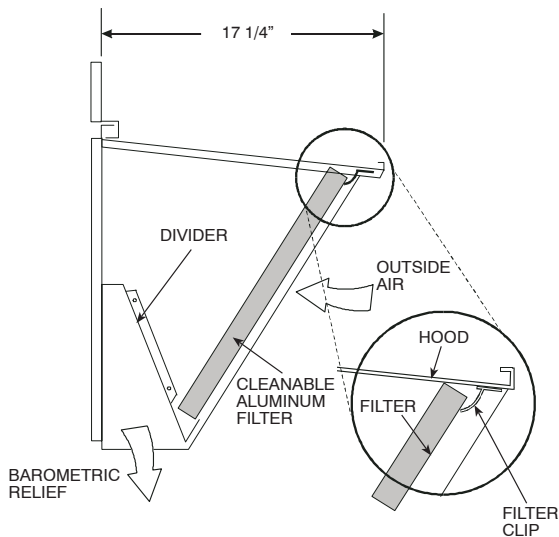
The outdoor air temperature sensor (HH57AC074) is a 10 to 20 mA device used to measure the outdoor-air temperature. The outdoor-air temperature is used to determine when the EconoMi\$er IV can be used for free cooling. The sensor is factory-installed on the EconoMi\$er IV in the outdoor airstream. (See Fig. 29.) The operating range of temperature measurement is 40° to 100°F.

### Supply Air Temperature (SAT) Sensor

The supply air temperature sensor is a 3 K thermistor located at the inlet of the indoor fan. (See Fig. 41.) This sensor is factory installed. The operating range of temperature measurement is 0° to 158°F. See Table 6 for sensor temperature/resistance values.

**Table 6—Supply Air Sensor Temperature/Resistance Values**

TEMPERATURE (F)	RESISTANCE (ohms)
-58	200,250
-40	100,680
-22	53,010
-4	29,091
14	16,590
32	9,795
50	5,970
68	3,747
77	3,000
86	2,416
104	1,597
122	1,080
140	746
158	525
176	376
185	321
194	274
212	203
230	153
248	116
257	102
266	89
284	70
302	55



**Fig. 35 – Filter Installation**

The temperature sensor looks like an eyelet terminal with wires running to it. The sensor is located in the “crimp end” and is sealed from moisture.

### Outdoor Air Lockout Sensor

The EconoMi\$er IV is equipped with an ambient temperature lockout switch located in the outdoor air stream which is used to lockout the compressors below a 42°F ambient temperature. (See Fig. 29.)

### ECONOMI\$ER IV CONTROL MODES

**IMPORTANT:** The optional EconoMi\$er2 does not include a controller. The EconoMi\$er2 is operated by a 4 to 20 mA<sub>signal</sub> from an existing field-supplied controller (such as PremierLink™ control). See Fig. 37 for wiring information.

Determine the EconoMi\$er IV control mode before set up of the control. Some modes of operation may require different sensors. Refer to Table 7. The EconoMi\$er IV is supplied from the factory with a supply-air temperature sensor and an outdoor-air temperature sensor. This allows for operation of the EconoMi\$er IV with outdoor air dry bulb changeover control. Additional accessories can be added to allow for different types of changeover control and operation of the EconoMi\$er IV and unit.

**Table 7—Economi\$er iv sensor usage**

APPLICATION	ECONOMI\$ER IV WITH OUTDOOR AIR DRY BULB SENSOR		
	Accessories Required		
Outdoor Air Dry Bulb	None. The outdoor air dry bulb sensor is factory installed.		
Differential Dry Bulb	CRTEMPSN002A00*		
Single Enthalpy	HH57AC078		
Differential Enthalpy	HH57AC078 and CRENTDIF004A00*		
CO <sub>2</sub> for DCV Control using a Wall-Mounted CO <sub>2</sub> Sensor	33ZCSENCO2		
CO <sub>2</sub> for DCV Control using a Duct-Mounted CO <sub>2</sub> Sensor	33ZCSENCO2† and 33ZCASPCO2**	O R	CRCBDIOX005A00††

\*CRENTDIF004A00 and CRTEMPSN002A00 accessories are used on many different base units. As such, these kits may contain parts that will not be needed for installation.

† 33ZCSENCO2 is an accessory CO<sub>2</sub> sensor.

\*\* 33ZCASPCO2 is an accessory aspirator box required for duct-mounted applications.

†† CRCBDIOX005A00 is an accessory that contains both 33ZCSENCO2 and 33ZCASPCO2 accessories.

### Outdoor Dry Bulb Changeover

The standard controller is shipped from the factory configured for outdoor dry bulb changeover control. The outdoor-air and supply-air temperature sensors are included as standard. For this control mode, the outdoor temperature is compared to an adjustable set point selected on the control. If the outdoor-air temperature is above the set point, the EconoMi\$er IV will adjust the outdoor-air dampers to minimum position. If the outdoor air temperature is below the set point, the position of the outdoor air dampers will be controlled to provide free cooling using outdoor air. When in this mode, the LED next to the free cooling set point potentiometer will be on. The changeover temperature set point is controlled by the free cooling set point potentiometer located on the control. (See Fig. 42.) The scale on the potentiometer is A, B, C, and D. See Fig. 43 for the corresponding temperature changeover values.

### Differential Dry Bulb Control

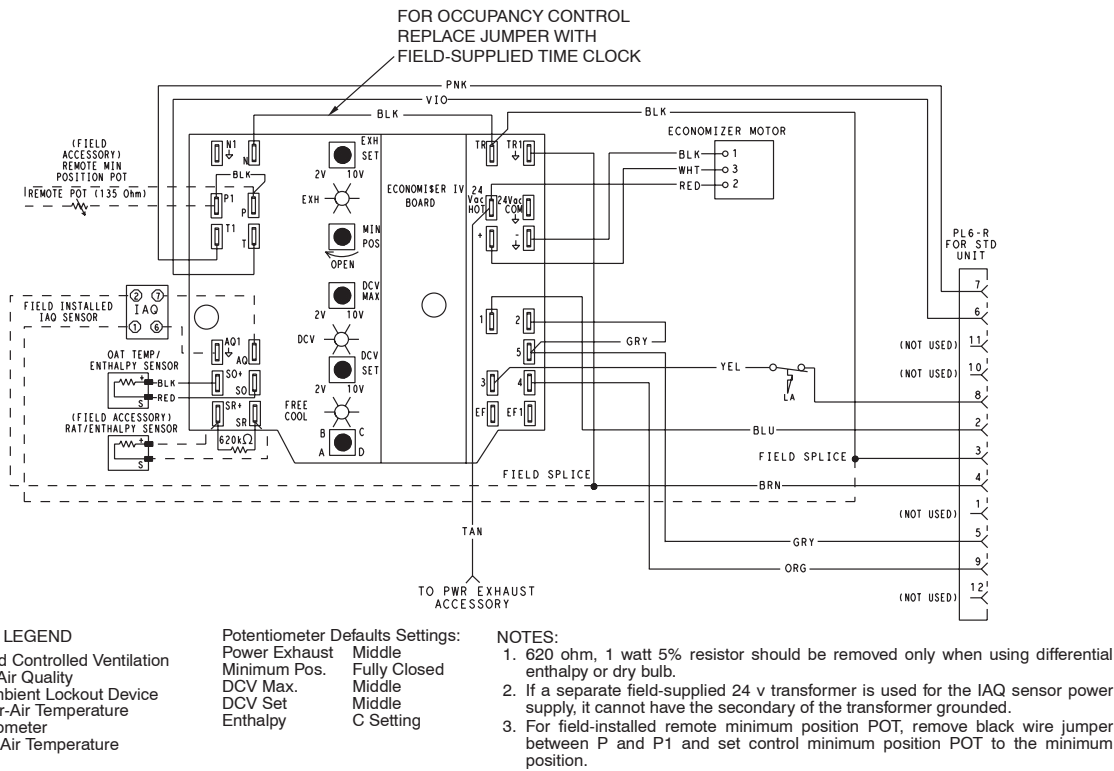
For differential dry bulb control the standard outdoor dry bulb sensor is used in conjunction with an additional accessory dry bulb sensor (part number CRTEMPSN002A00). The accessory sensor must be mounted in the return airstream. (See Fig. 44.) Wiring is provided in the EconoMi\$er IV wiring harness. (See Fig. 36.)

In this mode of operation, the outdoor-air temperature is compared to the return-air temperature and the lower temperature airstream is used for cooling. When using this mode of changeover control, turn the enthalpy setpoint potentiometer fully clockwise to the D setting. (See Fig. 42.)

48HE,HJ

C06027

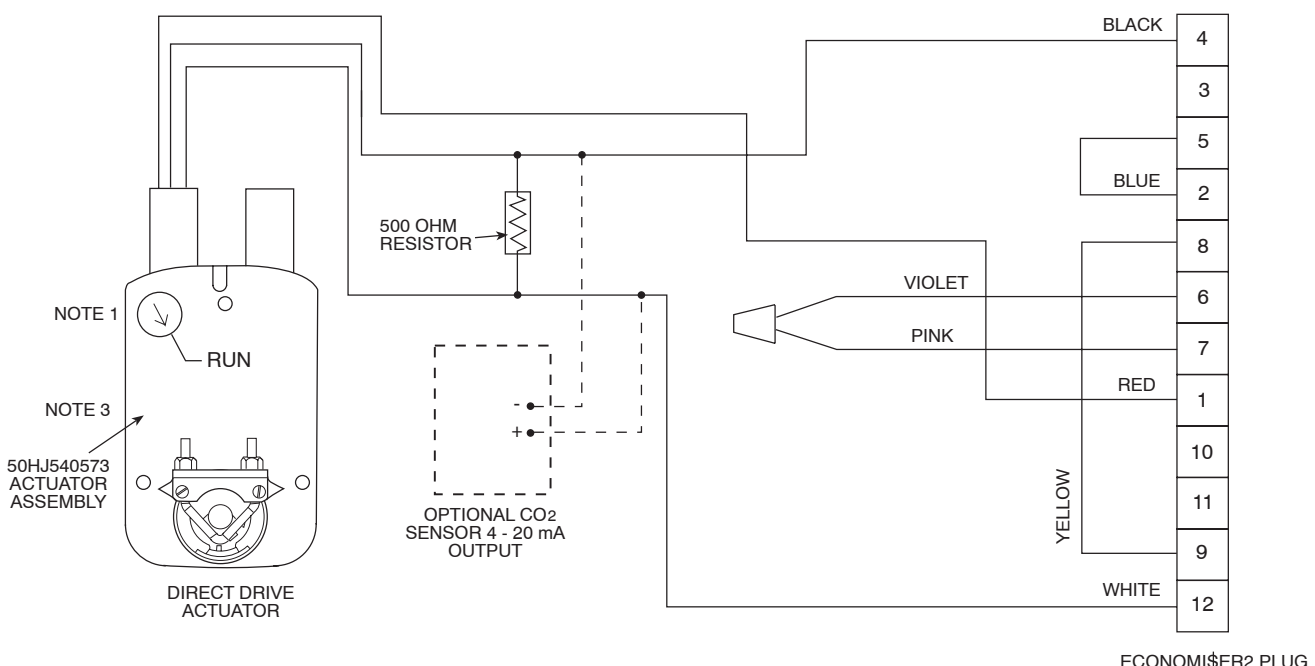




**Fig. 36 – EconoMi\$er IV Wiring**

C06028

48HE,HJ



- NOTES:**
- Switch on actuator must be in run position for economizer to operate.
  - PremierLink™ control requires that the standard 50HJ540569 outside-air sensor be replaced by either the CROASENR001A00 dry bulb sensor or HH57A077 enthalpy sensor.
  - 50HJ540573 actuator consists of the 50HJ540567 actuator and a harness with 500-ohm resistor.

**Fig. 37 – EconoMi\$er2 with 4 to 20 mA Control Wiring**

C06029

**Outdoor Enthalpy Changeover**

For enthalpy control, accessory enthalpy sensor (part number HH57AC078) is required. Replace the standard outdoor dry bulb temperature sensor with the accessory enthalpy sensor in the same mounting location. (See Fig. 29.) When the outdoor air enthalpy rises above the outdoor enthalpy changeover set point, the outdoor-air damper moves to its minimum position. The outdoor

enthalpy changeover set point is set with the outdoor enthalpy set point potentiometer on the EconoMi\$er IV controller. The set points are A, B, C, and D. (See Fig. 45.) The factory-installed 620-ohm jumper must be in place across terminals SR and SR+ on the EconoMi\$er IV controller. (See Fig. 29 and 46.)

## Differential Enthalpy Control

For differential enthalpy control, the EconoMi\$er IV controller uses two enthalpy sensors (HH57AC078 and CRENTDIF004A00), one in the outside air and one in the return air duct. The EconoMi\$er IV controller compares the outdoor air enthalpy to the return air enthalpy to determine EconoMi\$er IV use. The controller selects the lower enthalpy air (return or outdoor) for cooling. For example, when the outdoor air has a lower enthalpy than the return air, the EconoMi\$er IV opens to bring in outdoor air for free cooling.

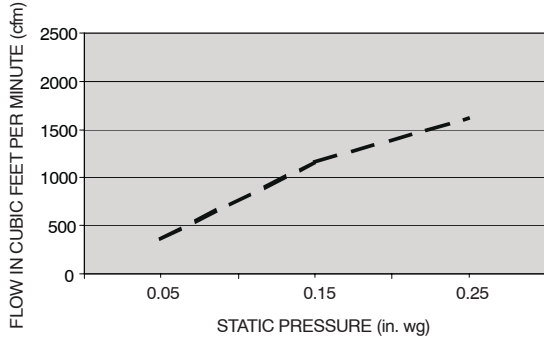


Fig. 38 – Barometric Flow Capacity

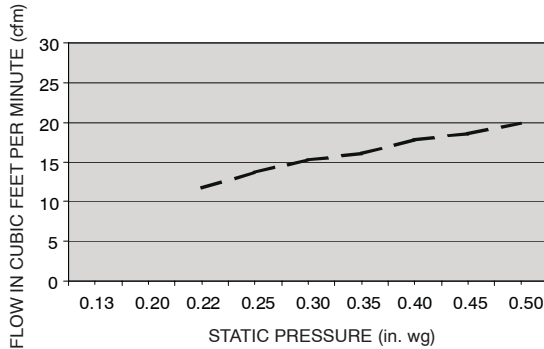


Fig. 39 – Outdoor-Air Damper Leakage

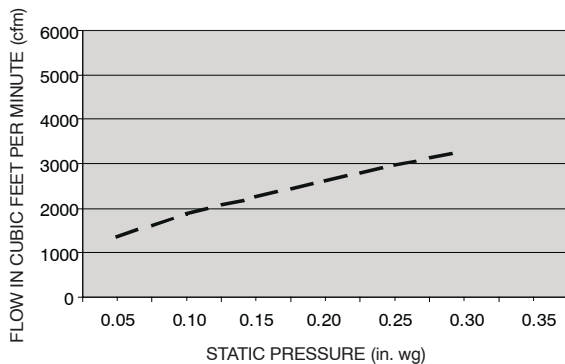


Fig. 40 – Return-Air Pressure Drop

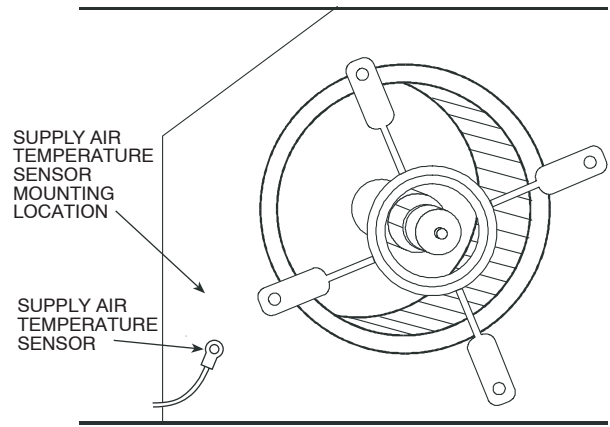


Fig. 41 – Supply Air Sensor Location

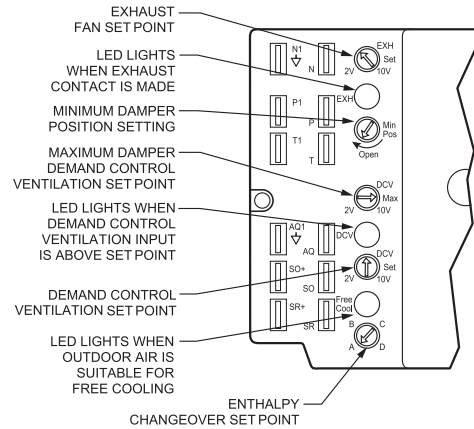


Fig. 42 – EconoMi\$er IV Controller Potentiometer and LED Locations

Replace the standard outside air dry bulb temperature sensor with the accessory enthalpy sensor in the same mounting location. (See Fig. 29.) Mount the return air enthalpy sensor in the return air duct. (See Fig. 44.) Wiring is provided in the EconoMi\$er IV wiring harness. (See Fig. 36.) The outdoor enthalpy changeover set point is set with the outdoor enthalpy set point potentiometer on the EconoMi\$er IV controller. When using this mode of changeover control, turn the enthalpy setpoint potentiometer fully clockwise to the D setting.

### Indoor Air Quality (IAQ) Sensor Input

The IAQ input can be used for demand control ventilation control based on the level of CO<sub>2</sub> measured in the space or return air duct.

Mount the accessory IAQ sensor according to manufacturer specifications. The IAQ sensor should be wired to the AQ and AQ1 terminals of the controller. Adjust the DCV potentiometers to correspond to the DCV voltage output of the indoor air quality sensor at the user-determined set point. (See Fig. 47.)

If a separate field-supplied transformer is used to power the IAQ sensor, the sensor must not be grounded or the EconoMi\$er IV control board will be damaged.

### Exhaust Set Point Adjustment

The exhaust set point will determine when the exhaust fan runs based on damper position (if accessory power exhaust is installed). The set point is modified with the Exhaust Fan Set Point (EXH SET) potentiometer. (See Fig. 42.) The set point represents the damper position above which the exhaust fans will be turned on. When there is a call for exhaust, the EconoMi\$er IV controller provides a 45 ± 15 second delay before exhaust fan

48HE,HJ

C06030

C06031

C06032

C06033

C06034

activation to allow the dampers to open. This delay allows the damper to reach the appropriate position to avoid unnecessary fan overload.

### Minimum Position Control

There is a minimum damper position potentiometer on the EconoMi\$er IV controller. (See Fig. 42.) The minimum damper position maintains the minimum airflow into the building during the occupied period.

When using demand ventilation, the minimum damper position represents the minimum ventilation position for VOC (volatile organic compound) ventilation requirements. The maximum demand ventilation position is used for fully occupied ventilation.

When demand ventilation control is not being used, the minimum position potentiometer should be used to set the occupied ventilation position. The maximum demand ventilation position should be turned fully clockwise.

Adjust the minimum position potentiometer to allow the minimum amount of outdoor air, as required by local codes, to enter the building. Make minimum position adjustments with at least 10°F temperature difference between the outdoor and return-air temperatures.

To determine the minimum position setting, perform the following procedure:

1. Calculate the appropriate mixed air temperature using the following formula:

$$(T_O \times \frac{OA}{100}) + (T_R \times \frac{RA}{100}) = T_M$$

$T_O$  = Outdoor-Air Temperature

OA = Percent of Outdoor Air

$T_R$  = Return-Air Temperature

RA = Percent of Return Air

$T_M$  = Mixed-Air Temperature

As an example, if local codes require 10% outdoor air during occupied conditions, outdoor-air temperature is 60°F, and return-air temperature is 75°F.

$$(60 \times .10) + (75 \times .90) = 73.5^\circ\text{F}$$

2. Disconnect the supply air sensor from terminals T and T1.
3. Ensure that the factory-installed jumper is in place across terminals P and P1. If remote damper positioning is being used, make sure that the terminals are wired according to Fig. 36 and that the minimum position potentiometer is turned fully clockwise.
4. Connect 24 vac across terminals TR and TR1.
5. Carefully adjust the minimum position potentiometer until the measured supply air temperature matches the calculated value.
6. Reconnect the mixed air sensor to terminals T and T1.

Remote control of the EconoMi\$er IV damper is desirable when requiring additional temporary ventilation. If a field-supplied remote potentiometer (Honeywell part number S963B1128) is wired to the EconoMi\$er IV controller, the minimum position of the damper can be controlled from a remote location.

To control the minimum damper position remotely, remove the factory-installed jumper on the P and P1 terminals on the EconoMi\$er IV controller. Wire the field-supplied potentiometer to the P and P1 terminals on the EconoMi\$er IV controller. (See Fig. 46.)

### Damper Movement

Damper movement from full open to full closed (or vice versa) takes 2½ minutes.

### Thermostats

The EconoMi\$er IV control works with conventional thermostats that have a Y1 (cool stage 1), Y2 (cool stage 2), W1 (heat stage 1), W2 (heat stage 2), and G (fan). The EconoMi\$er IV control does not support space temperature sensors. Connections are made at the thermostat terminal connection board located in the main control box.

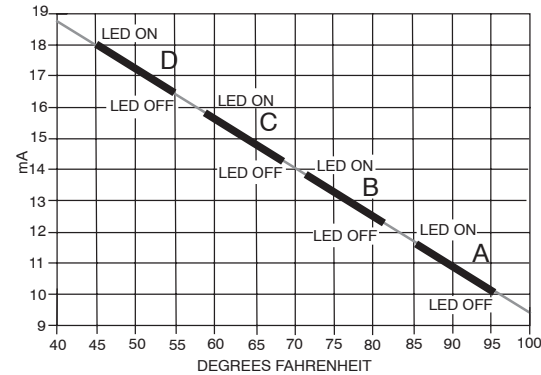


Fig. 43 – Outside Air Temperature Changeover Set Points

C06035

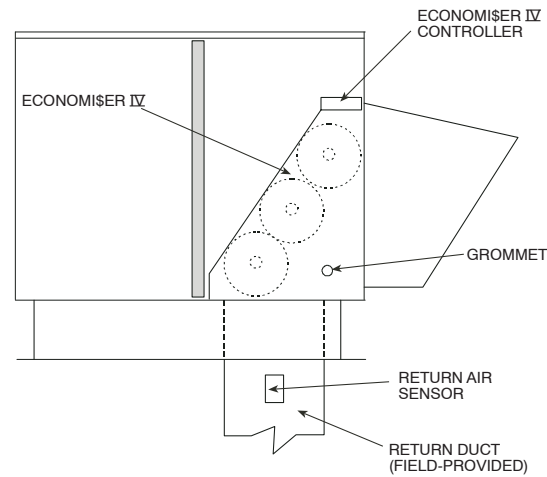


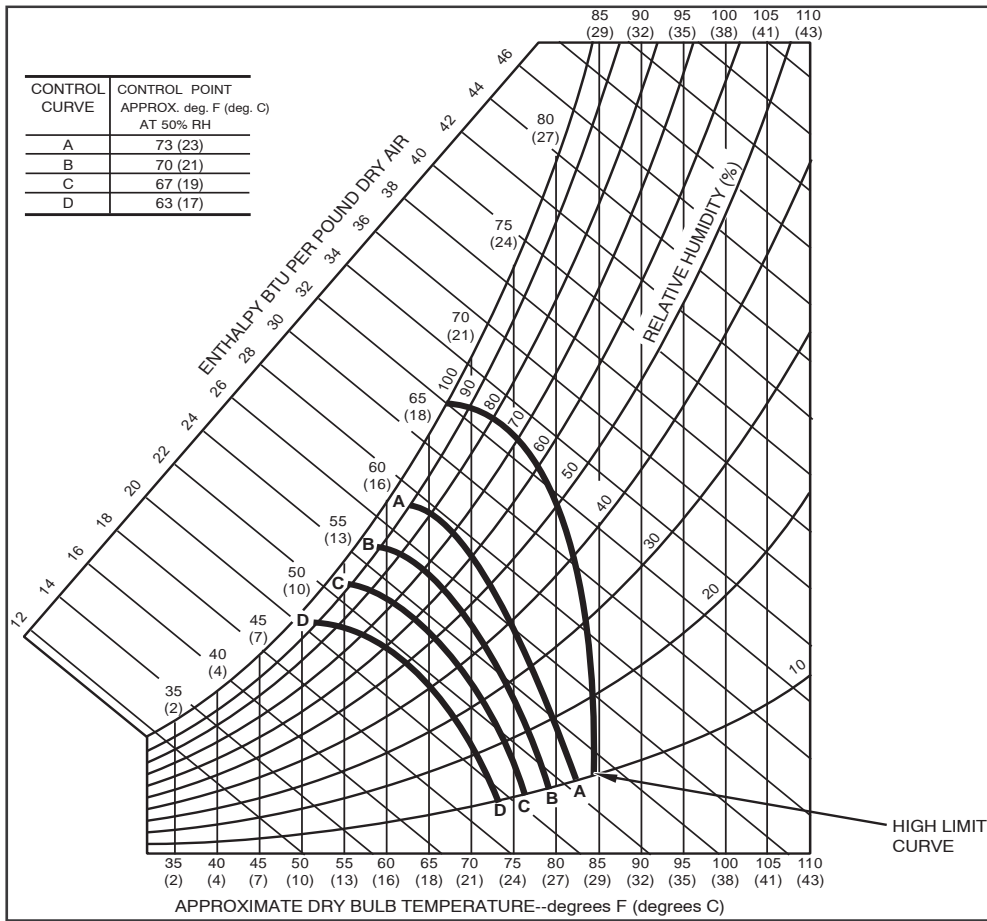
Fig. 44 – Return Air Temperature or Enthalpy Sensor Mounting Location

C06036

### Occupancy Control

The factory default configuration for the EconoMi\$er IV control is occupied mode. Occupied mode is provided by the black jumper from terminal TR to terminal N. When unoccupied mode is desired, install a field-supplied timeclock function in place of the jumper between TR and N. (See Fig. 36.) When the timeclock contacts are closed, the EconoMi\$er IV control will be in occupied mode. When the timeclock contacts are open (removing the 24-v signal from terminal N), the EconoMi\$er IV will be in unoccupied mode.

48HE\_HJ



**Fig. 45 – Enthalpy Changeover Set Points**

C06037

Typically the maximum ventilation rate will be about 5 to 10% more than the typical cfm required per person, using normal outside air design criteria.

**Demand Controlled Ventilation (DCV)**

When using the EconoMi\$er IV for demand controlled ventilation, there are some equipment selection criteria which should be considered. When selecting the heat capacity and cool capacity of the equipment, the maximum ventilation rate must be evaluated for design conditions. The maximum damper position must be calculated to provide the desired fresh air.

A proportional anticipatory strategy should be taken with the following conditions: a zone with a large area, varied occupancy, and equipment that cannot exceed the required ventilation rate at design conditions. Exceeding the required ventilation rate means the equipment can condition air at a maximum ventilation rate that is greater than the required ventilation rate for maximum occupancy. A proportional-anticipatory strategy will cause the fresh air supplied to increase as the room CO<sub>2</sub> level increases even though the CO<sub>2</sub> set point has not been reached. By the time the CO<sub>2</sub> level reaches the set point, the damper will be at maximum ventilation and should maintain the set point.

In order to have the CO<sub>2</sub> sensor control the economizer damper in this manner, first determine the damper voltage output for minimum or base ventilation. Base ventilation is the ventilation required to remove contaminants during unoccupied periods. The following equation may be used to determine the percent of outside-air entering the building for a given damper position. For best results there should be at least a 10 degree difference in outside and return-air temperatures.

$$(T_O \times \frac{OA}{100}) + (T_R \times \frac{RA}{100}) = T_M$$

- T<sub>O</sub> = Outdoor-Air Temperature
- OA = Percent of Outdoor Air
- T<sub>R</sub> = Return-Air Temperature
- RA = Percent of Return Air
- T<sub>M</sub> = Mixed-Air Temperature

Once base ventilation has been determined, set the minimum damper position potentiometer to the correct position.

The same equation can be used to determine the occupied or maximum ventilation rate to the building. For example, an output of 3.6 volts to the actuator provides a base ventilation rate of 5% and an output of 6.7 volts provides the maximum ventilation rate of 20% (or base plus 15 cfm per person). Use Fig. 44 to determine the maximum setting of the CO<sub>2</sub> sensor. For example, a 1100 ppm set point relates to a 15 cfm per person design. Use the 1100 ppm curve on Fig. 47 to find the point when the CO<sub>2</sub> sensor output will be 6.7 volts. Line up the point on the graph with the left side of the chart to determine that the range configuration for the CO<sub>2</sub> sensor should be 1800 ppm. The EconoMi\$er IV controller will output the 6.7 volts from the CO<sub>2</sub> sensor to the actuator when the CO<sub>2</sub> concentration in the space is at 1100 ppm. The DCV set point may be left at 2 volts since the CO<sub>2</sub> sensor voltage will be ignored by the EconoMi\$er IV controller until it rises above the 3.6 volt setting of the minimum position potentiometer.

Once the fully occupied damper position has been determined, set the maximum damper demand control ventilation potentiometer to this position. Do not set to the maximum position as this can result in over-ventilation to the space and potential high-humidity levels.

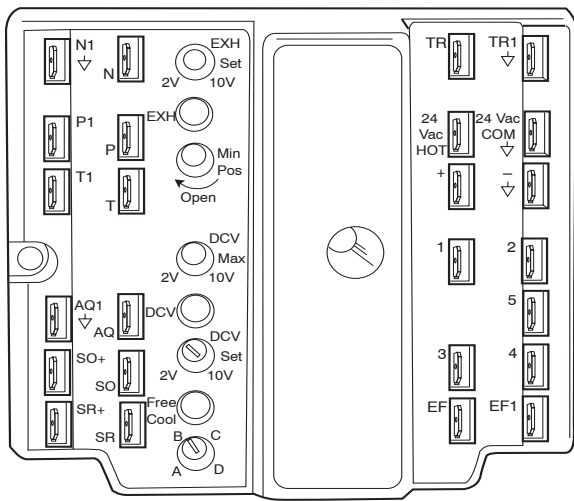


Fig. 46 – EconoMiSer IV Control

C06038

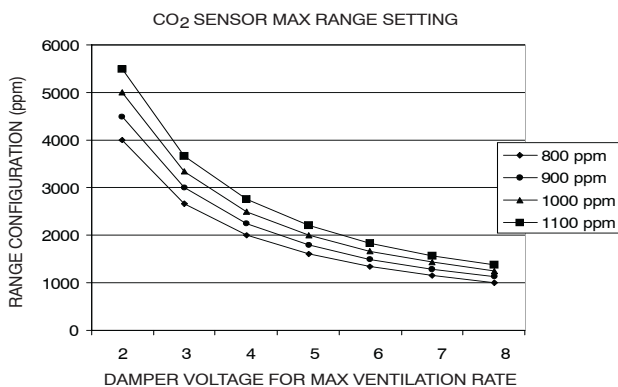


Fig. 47 – CO<sub>2</sub> Sensor Maximum Range Setting

C06039

### CO<sub>2</sub> Sensor Configuration

The CO<sub>2</sub> sensor has preset standard voltage settings that can be selected anytime after the sensor is powered up. (See Table 8.)

Use setting 1 or 2 for Carrier equipment. (See Table 8.)

1. Press Clear and Mode buttons. Hold at least 5 seconds until the sensor enters the Edit mode.
2. Press Mode twice. The STDSET Menu will appear.
3. Use the Up/Down button to select the preset number. (See Table 8.)
4. Press Enter to lock in the selection.
5. Press Mode to exit and resume normal operation.

The custom settings of the CO<sub>2</sub> sensor can be changed anytime after the sensor is energized. Follow the steps below to change the non-standard settings:

1. Press Clear and Mode buttons. Hold at least 5 seconds until the sensor enters the Edit mode.
2. Press Mode twice. The STDSET Menu will appear.
3. Use the Up/Down button to toggle to the NONSTD menu and press Enter.
4. Use the Up/Down button to toggle through each of the nine variables, starting with Altitude, until the desired setting is reached.
5. Press Mode to move through the variables.
6. Press Enter to lock in the selection, then press Mode to continue to the next variable.

### Dehumidification of Fresh Air with DCV Control

Information from ASHRAE indicates that the largest humidity load on any zone is the fresh air introduced. For some applications, a device such as a 62AQ energy recovery unit is added to reduce the moisture content of the fresh air being brought into the building when the enthalpy is high. In most cases, the normal heating and cooling processes are more than adequate to remove the humidity loads for most commercial applications.

If normal rooftop heating and cooling operation is not adequate for the outdoor humidity level, an energy recovery unit and/or a dehumidification option should be considered.

#### Step 9 —Adjust Evaporator-Fan Speed

Adjust evaporator-fan speed to meet jobsite conditions.

Tables 9 and 10 show fan rpm at motor pulley settings. Tables 11 and 15 show maximum amp draw of belt-drive motor. Table 14 shows sound data. Refer to Tables 16-35 for performance data. See Table 36 for accessory static pressure drop. See Fig. 48 for the Humidi-MiZer™ system static pressure drops.

#### Belt drive motors

Fan motor pulleys are factory set for speed shown in Table 1 or 2. Check pulley alignment and belt tension prior to start-up.

To change fan speed:

1. Shut off the unit power supply and tag disconnect.
2. Loosen the belt by loosening the fan motor mounting nuts. (See Fig. 49.)
3. Loosen movable pulley flange setscrew. (See Fig. 50.)
4. Screw movable flange toward fixed flange to increase speed and away from fixed flange to decrease speed. Increasing fan speed increases load on motor. Do not exceed maximum speed specified in Table 1 or 2.
5. Set movable flange at nearest keyway of pulley hub and tighten setscrew. (See Table 1 or 2 for speed change for each full turn of pulley flange.)
6. Adjust belt tension and align fan and motor pulleys per guidance below.

To align fan and motor pulleys, loosen fan pulley setscrews and slide fan pulley along fan shaft. Make angular alignment by loosening motor from mounting.

Additional motor and fan alignment, as well as angular alignment can be made by loosening the four motor mounting bolts from the mounting plate.

To adjust belt tension:

1. Loosen the two motor mounting nuts as shown in Fig. 49. Some models may have a third mounting nut located on the opposite side of the fan motor mounting plate.
2. Slide motor mounting plate away from fan scroll for proper belt tension ( $\frac{1}{2}$ -in. deflection with 8 to 10 lb of force) and tighten mounting nuts.
3. Adjust lock bolt and nut on mounting plate to secure motor in fixed position.

Table 8—CO<sub>2</sub> Sensor Standard Settings

SETTING	EQUIPMENT	OUTPUT	VENTILATION RATE (cfm/Person)	ANALOG OUTPUT	CO <sub>2</sub> CONTROL RANGE (ppm)	OPTIONAL RELAY SETPOINT (ppm)	RELAY HYSTERESIS (ppm)
1	Interface w/Standard Building Control System	Proportional	Any	0-10V 4-20 mA	0-2000	1000	50
2		Proportional	Any	2-10V 7-20 mA	0-2000	1000	50
3		Exponential	Any	0-10V 4-20 mA	0-2000	1100	50
4	Economizer	Proportional	15	0-10V 4-20 mA	0-1100	1100	50
5		Proportional	20	0-10V 4-20 mA	0- 900	900	50
6		Exponential	15	0-10V 4-20 mA	0-1100	1100	50
7		Exponential	20	0-10V 4-20 mA	0- 900	900	50
8	Health & Safety	Proportional	—	0-10V 4-20 mA	0-9999	5000	500
9	Parking/Air Intakes/ Loading Docks	Proportional	—	0-10V 4-20 mA	0-2000	700	50

48HE,HJ

LEGEND  
ppm — Parts Per Million

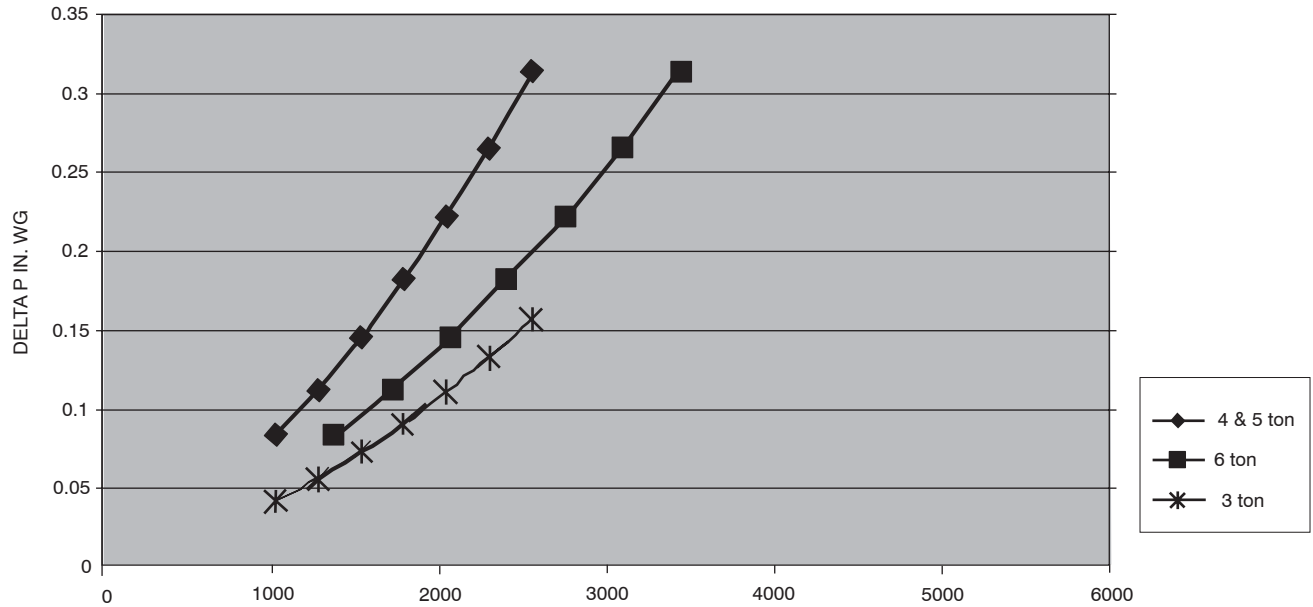


Fig. 48 – Humidi-MiZer™ Adaptive Dehumidification System Static Pressure Drop (in. wg)

C06133

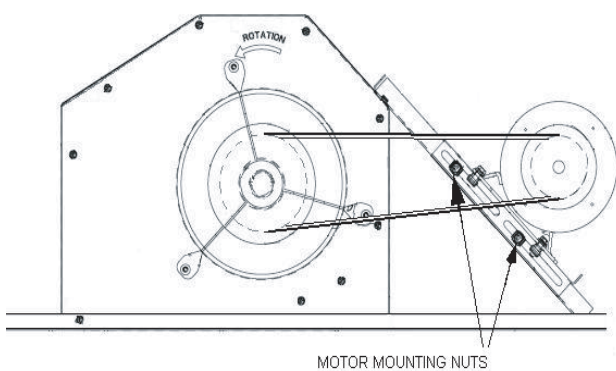


Fig. 49 – Belt Drive Motor Mounting

C06134

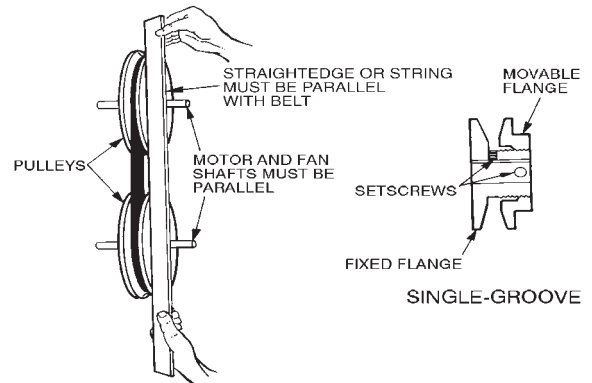


Fig. 50 – Indoor-Fan Pulley Adjustment

C06041

**Table 9—48HJ and 48he Fan Rpm at Motor Pulley Setting With Standard Motor\***

UNIT 48HJ 48HE	MOTOR PULLEY TURNS OPEN												
	0	1/2	1	1 1/2	2	2 1/2	3	3 1/2	4	4 1/2	5	5 1/2	6
003	936	906	876	846	816	786	756	726	696	666	639	—	—
004	1044	1008	971	935	898	862	826	789	753	716	680	—	—
005	1185	1144	1102	1061	1019	978	936	895	853	812	770	—	—
006	1460	1425	1389	1354	1318	1283	1248	1212	1177	1141	1106	1070	1035
007	1585	1538	1492	1445	1399	1352	1305	1259	1212	1166	1119	—	—

\*Approximate fan rpm shown (standard motor/drive).

**Table 10—48HJ Fan Rpm at Motor Pulley Setting With High-Static Motor\***

UNIT 48HJ 48HE	MOTOR PULLEY TURNS OPEN												
	0	1/2	1	1 1/2	2	2 1/2	3	3 1/2	4	4 1/2	5	5 1/2	6
004	1455	1423	1392	1360	1328	1297	1265	1233	1202	1170	1138	1107	1075
005	1455	1423	1392	1360	1328	1297	1265	1233	1202	1170	1138	1107	1075
006	1685	1589	1557	1525	1493	1460	1428	1396	1364	1332	1300	—	—
007	1685	1589	1557	1525	1493	1460	1428	1396	1364	1332	1300	—	—

\*Approximate fan rpm shown (high-static motor/drive).

**Table 11—Evaporator-Fan Motor Data — Standard Motor**

UNIT 48HJ 48HE	UNIT PHASE	MAXIMUM CONTINUOUS BHP*	MAXIMUM OPERATING WATTS*	UNIT VOLTAGE	MAXIMUM AMP DRAW
003	Single	0.58	580	208/230	2.0
	Single	1.20	1000	208/230	4.9
004	Three	1.20	1000	208/230	4.9
				460	2.2
				575	2.2
005	Single	1.20	1000	208/230	4.9
				208/230	4.9
				460	2.2
005	Three	1.20	1000	208/230	4.9
				208/230	4.9
				460	2.2
006	Single	1.30	1650	208/230	9.2
				208/230	6.7
				460	3.0
006	Three	2.40	2120	575	3.0
				208/230	6.7
				460	3.0
007	Three	2.40	2120	208/230	6.7
				460	3.0
				575	3.0

LEGEND

**Bhp** — Brake Horsepower

\*Extensive motor and electrical testing on these units ensures that the full horsepower and watts range of the motors can be utilized with confidence. Using the fan motors up to the ratings shown in this table will not result in nuisance tripping or premature motor failure. Unit warranty will not be affected.

**Table 12—Accessory static pressure**

COMPONENT	CFM										
	600	800	1000	1250	1500	1750	2000	2250	2500	2750	3000
Vertical EconoMi\$er IV and EconoMi\$er2	0.010	0.020	0.035	0.045	0.065	0.080	0.120	0.145	0.175	0.220	0.255
Horizontal EconoMi\$er IV and EconoMi\$er2	—	—	—	—	—	0.100	0.125	0.150	0.180	0.225	0.275

**Table 13—Evaporator-Fan Motor Data — High-Static Motors**

UNIT 48HJ	UNIT PHASE	MAXIMUM CONTINUOUS BHP*	MAXIMUM OPERATING WATTS*	UNIT VOLTAGE	MAXIMUM AMP DRAW
004	Three	2.40	2120	208/230	6.7
				460	3.0
				575	3.0
005	Three	2.40	2120	208/230	6.7
				460	3.0
				575	3.0
006	Three	2.90	2615	208/230	8.6
				460	3.9
				575	3.9
007	Three	2.90	2615	208/230	8.6
				460	3.9
				575	3.9

LEGEND

**Bhp** — Brake Horsepower

\*Extensive motor and electrical testing on these units ensures that the full horsepower and watts range of the motors can be utilized with confidence. Using the fan motors up to the ratings shown in this table will not result in nuisance tripping or premature motor failure. Unit warranty will not be affected.

**48HE, HJ**

Table 14—48HJ Outdoor Sound Power (Total Unit)

UNIT 48HJ	ARI RATING (decibels)	OCTAVE BANDS							
		63	125	250	500	1000	2000	4000	8000
004,005	76	55.9	66.0	64.0	66.2	68.4	64.5	61.7	57.3
006,007	80	59.1	68.9	68.7	71.9	74.0	68.9	65.7	59.0

LEGEND

ARI – Air Conditioning and Refrigeration Institute

Table 15—48HE Outdoor Sound Power (Total Unit)

UNIT 48HE	ARI RATING (decibels)	A- WEIGHTED (db)	OCTAVE BANDS							
			63	125	250	500	1000	2000	4000	8000
003–005	76	76	55.9	66.0	64.0	66.2	68.4	64.5	61.7	57.3
006	80	80	59.1	68.9	68.7	71.9	74.0	68.9	65.7	59.0

### GENERAL FAN PERFORMANCE NOTES

1. Values include losses for filters, unit casing, and wet coils. See Table 31 and Fig. 44 for accessory/FIOP static pressure information.
2. Extensive motor and electrical testing on these units ensures that the full range of the motor can be utilized with confidence. Using the fan motors up to the ratings shown will not result in nuisance tripping or premature motor failure. Unit warranty will not be affected. See Tables 9 and 10 on this page for additional information.
3. Use of a field-supplied motor may affect wire sizing. Contact your Carrier representative to verify.
4. Interpolation is permissible. Do not extrapolate.

Table 16—Fan Performance 40HE003 — Vertical Discharge Units; Standard Motor (Belt Drive)\*\*

AIRFLOW (Cfm)	EXTERNAL STATIC PRESSURE (in. wg)											
	0.1		0.2		0.4		0.6		0.8		1.0	
	Rpm	Bhp	Rpm	Bhp	Rpm	Bhp	Rpm	Bhp	Rpm	Bhp	Rpm	Bhp
600	500	0.08	531	0.08	607	0.14	713	0.21	788	0.29	878	0.37
700	529	0.09	567	0.09	633	0.16	739	0.24	816	0.32	902	0.41
800	547	0.1	592	0.12	660	0.19	761	0.27	845	0.37	937	0.47
900	570	0.13	620	0.14	691	0.22	793	0.32	870	0.42	957	0.53
1000	599	0.15	650	0.16	717	0.26	818	0.36	894	0.47	981	0.58

48HE, HJ



**Table 17—Fan Performance 48HJ004, 48HE004 — Vertical Discharge Units; Standard Motor  
(Belt Drive)\***

AIRFLOW CFM	EXTERNAL STATIC PRESSURE (in. wg)														
	0.2			0.4			0.6			0.8			1.0		
	Rpm	Bhp	Watts	Rpm	Bhp	Watts	Rpm	Bhp	Watts	Rpm	Bhp	Watts	Rpm	Bhp	Watts
900	567	0.15	145	688	0.22	222	786	0.30	296	871	0.37	368	947	0.44	437
1000	599	0.18	177	717	0.27	265	814	0.35	349	897	0.43	430	972	0.51	509
1100	632	0.22	215	747	0.31	313	842	0.41	407	925	0.50	498	999	0.59	587
1200	666	0.26	257	778	0.37	367	871	0.47	471	952	0.57	572	1025	0.67	670
1300	701	0.31	306	810	0.43	426	901	0.54	540	981	0.65	651	1053	0.76	760
1400	737	0.36	361	842	0.49	491	931	0.62	616	1010	0.74	738	1081	0.86	856
1500	773	0.42	422	875	0.57	564	963	0.70	699	1040	0.84	831	1110	0.96	960

AIRFLOW CFM	EXTERNAL STATIC PRESSURE (in. wg)														
	1.2			1.4			1.6			1.8			2.0		
	Rpm	Bhp	Watts	Rpm	Bhp	Watts	Rpm	Bhp	Watts	Rpm	Bhp	Watts	Rpm	Bhp	Watts
900	1016	0.51	505	1080	0.57	572	1139	0.64	637	1195	0.71	702	1249	0.77	765
1000	1041	0.59	587	1104	0.67	662	1163	0.74	737	1219	0.81	811	1272	0.89	883
1100	1066	0.68	674	1129	0.76	759	1188	0.85	843	1243	0.93	925	1296	1.01	1007
1200	1093	0.77	767	1155	0.87	861	1213	0.96	955	1268	1.05	1047	1321	1.14	1137
1300	1119	0.87	866	1181	0.98	970	1239	1.08	1073	1294	1.18	1175	—	—	—
1400	1147	0.98	972	1208	1.09	1086	—	—	—	—	—	—	—	—	—
1500	1175	1.09	1086	—	—	—	—	—	—	—	—	—	—	—	—

NOTES:

1. Grey cells indicate field-supplied drive is required.
2. Maximum continuous bhp is 1.20.
3. See general fan performance notes.

LEGEND

**Bhp** — Brake Horsepower  
**Watts** — Input Watts to Motor

\*Motor drive range: 680 to 1044 rpm. All other rpms require field-supplied drive.

**Table 18—Fan Performance 48HJ004, 48HE004 — Vertical Discharge Units; High-Static Motor  
(Belt Drive)\***

AIRFLOW CFM	EXTERNAL STATIC PRESSURE (in. wg)														
	0.2			0.4			0.6			0.8			1.0		
	Rpm	Bhp	Watts	Rpm	Bhp	Watts	Rpm	Bhp	Watts	Rpm	Bhp	Watts	Rpm	Bhp	Watts
900	567	0.15	145	688	0.22	222	786	0.30	296	871	0.37	368	947	0.44	437
1000	599	0.18	177	717	0.27	265	814	0.35	349	897	0.43	430	972	0.51	509
1100	632	0.22	215	747	0.31	313	842	0.41	407	925	0.50	498	999	0.59	587
1200	666	0.26	257	778	0.37	367	871	0.47	471	952	0.57	572	1025	0.67	670
1300	701	0.31	306	810	0.43	426	901	0.54	540	981	0.65	651	1053	0.76	760
1400	737	0.36	361	842	0.49	491	931	0.62	616	1010	0.74	738	1081	0.86	856
1500	773	0.42	422	875	0.57	564	963	0.70	699	1040	0.84	831	1110	0.96	960

AIRFLOW CFM	EXTERNAL STATIC PRESSURE (in. wg)														
	1.2			1.4			1.6			1.8			2.0		
	Rpm	Bhp	Watts	Rpm	Bhp	Watts	Rpm	Bhp	Watts	Rpm	Bhp	Watts	Rpm	Bhp	Watts
900	1016	0.51	505	1080	0.57	572	1139	0.64	637	1195	0.71	702	1249	0.77	765
1000	1041	0.59	587	1104	0.67	662	1163	0.74	737	1219	0.81	811	1272	0.89	883
1100	1066	0.68	674	1129	0.76	759	1188	0.85	843	1243	0.93	925	1296	1.01	1007
1200	1093	0.77	767	1155	0.87	861	1213	0.96	955	1268	1.05	1047	1321	1.14	1137
1300	1119	0.87	866	1181	0.98	970	1239	1.08	1073	1294	1.18	1175	1346	1.28	1275
1400	1147	0.98	972	1208	1.09	1086	1265	1.21	1199	1320	1.32	1310	1371	1.43	1419
1500	1175	1.09	1086	1235	1.22	1209	1292	1.34	1332	1346	1.46	1452	1397	1.58	1572

NOTES:

1. Grey cells indicate field-supplied drive is required.
2. Maximum continuous bhp is 2.40.
3. See general fan performance notes.

LEGEND

**Bhp** — Brake Horsepower  
**Watts** — Input Watts to Motor

\*Motor drive range: 1075 to 1455 rpm. All other rpms require field-supplied drive.

**48HE, HJ**

**Table 19— Fan Performance 48HJ005, 48HE005 — Vertical Discharge Units; Standard Motor  
(Belt Drive)\***

AIRFLOW CFM	EXTERNAL STATIC PRESSURE (in. wg)														
	0.2			0.4			0.6			0.8			1.0		
	Rpm	Bhp	Watts	Rpm	Bhp	Watts	Rpm	Bhp	Watts	Rpm	Bhp	Watts	Rpm	Bhp	Watts
1200	666	0.26	257	778	0.37	367	871	0.47	471	952	0.57	572	1025	0.67	670
1300	701	0.31	306	810	0.43	426	901	0.54	540	981	0.65	651	1053	0.76	760
1400	737	0.36	361	842	0.49	491	931	0.62	616	1010	0.74	738	1081	0.86	856
1500	773	0.42	422	875	0.57	564	963	0.70	699	1040	0.84	831	1110	0.96	960
1600	810	0.49	491	909	0.65	643	994	0.79	790	1070	0.94	932	1140	1.08	1070
1700	847	0.57	567	943	0.73	730	1027	0.89	888	1101	1.05	1040	1170	1.20	1189
1800	885	0.66	652	978	0.83	826	1060	1.00	994	1133	1.16	1157	—	—	—
1900	923	0.75	745	1014	0.94	930	1093	1.11	1109	—	—	—	—	—	—
2000	962	0.85	847	1049	1.05	1043	—	—	—	—	—	—	—	—	—

AIRFLOW CFM	EXTERNAL STATIC PRESSURE (in. wg)														
	1.2			1.4			1.6			1.8			2.0		
	Rpm	Bhp	Watts	Rpm	Bhp	Watts	Rpm	Bhp	Watts	Rpm	Bhp	Watts	Rpm	Bhp	Watts
1200	1093	0.77	767	1155	0.87	861	1213	0.96	955	1268	1.05	1047	1321	1.14	1137
1300	1119	0.87	866	1181	0.98	970	1239	1.08	1073	1294	1.18	1175	—	—	—
1400	1147	0.98	972	1208	1.09	1086	—	—	—	—	—	—	—	—	—
1500	1175	1.09	1086	—	—	—	—	—	—	—	—	—	—	—	—
1600	—	—	—	—	—	—	—	—	—	—	—	—	—	—	—
1700	—	—	—	—	—	—	—	—	—	—	—	—	—	—	—
1800	—	—	—	—	—	—	—	—	—	—	—	—	—	—	—
1900	—	—	—	—	—	—	—	—	—	—	—	—	—	—	—
2000	—	—	—	—	—	—	—	—	—	—	—	—	—	—	—

NOTES:

1. Grey cells indicate field-supplied drive is required.
2. Maximum continuous bhp is 2.40.
3. See general fan performance notes.

LEGEND

**Bhp** — Brake Horsepower  
**Watts** — Input Watts to Motor

\*Motor drive range: 770 to 1185 rpm. All other rpms require field-supplied drive.

**48HE,HJ**

Table 20—Fan Performance 48HJ005, 48HE005 — Vertical Discharge Units; High-Static Motor (Belt Drive)\*

AIRFLOW CFM	EXTERNAL STATIC PRESSURE (in. wg)														
	0.2			0.4			0.6			0.8			1.0		
	Rpm	Bhp	Watts	Rpm	Bhp	Watts	Rpm	Bhp	Watts	Rpm	Bhp	Watts	Rpm	Bhp	Watts
1200	666	0.26	257	778	0.37	367	871	0.47	471	952	0.57	572	1025	0.67	670
1300	701	0.31	306	810	0.43	426	901	0.54	540	981	0.65	651	1053	0.76	760
1400	737	0.36	361	842	0.49	491	931	0.62	616	1010	0.74	738	1081	0.86	856
1500	773	0.42	422	875	0.57	564	963	0.70	699	1040	0.84	831	1110	0.96	960
1600	810	0.49	491	909	0.65	643	994	0.79	790	1070	0.94	932	1140	1.08	1070
1700	847	0.57	567	943	0.73	730	1027	0.89	888	1101	1.05	1040	1170	1.20	1189
1800	885	0.66	652	978	0.83	826	1060	1.00	994	1133	1.16	1157	1200	1.32	1316
1900	923	0.75	745	1014	0.94	930	1093	1.11	1109	1165	1.29	1283	1231	1.46	1453
2000	962	0.85	847	1049	1.05	1043	1127	1.24	1233	1198	1.42	1417	1263	1.61	1598

AIRFLOW CFM	EXTERNAL STATIC PRESSURE (in. wg)														
	1.2			1.4			1.6			1.8			2.0		
	Rpm	Bhp	Watts	Rpm	Bhp	Watts	Rpm	Bhp	Watts	Rpm	Bhp	Watts	Rpm	Bhp	Watts
1200	1093	0.77	767	1155	0.87	861	1213	0.96	955	1268	1.05	1047	1321	1.14	1137
1300	1119	0.87	866	1181	0.98	970	1239	1.08	1073	1294	1.18	1175	1346	1.28	1275
1400	1147	0.98	972	1208	1.09	1086	1265	1.21	1199	1320	1.32	1310	1371	1.43	1419
1500	1175	1.09	1086	1235	1.22	1209	1292	1.34	1332	1346	1.46	1452	1397	1.58	1572
1600	1204	1.21	1207	1263	1.35	1340	1320	1.48	1472	1373	1.61	1603	1424	1.74	1732
1700	1233	1.34	1336	1292	1.49	1480	1348	1.63	1622	1401	1.77	1762	1451	1.91	1901
1800	1262	1.48	1473	1321	1.64	1627	1376	1.79	1779	1428	1.94	1930	1479	2.09	2078
1900	1293	1.63	1620	1350	1.79	1784	1405	1.96	1946	1457	2.12	2106	1506	2.28	2265
2000	1323	1.79	1776	1380	1.96	1950	1434	2.13	2123	1486	2.31	2293	—	—	—

NOTES:

1. Grey cells indicate field-supplied drive is required.
2. Maximum continuous bhp is 2.40.
3. See general fan performance notes.

LEGEND

**Bhp** — Brake Horsepower  
**Watts** — Input Watts to Motor

\*Motor drive range: 1075 to 1455 rpm. All other rpms require field-supplied drive.

Table 21—Fan Performance 48HJ006, 48HE006 Single-Phase — Vertical Discharge Units; Standard Motor (Belt Drive)\*

AIRFLOW CFM	EXTERNAL STATIC PRESSURE (in. wg)														
	0.2			0.4			0.6			0.8			1.0		
	Rpm	Bhp	Watts	Rpm	Bhp	Watts	Rpm	Bhp	Watts	Rpm	Bhp	Watts	Rpm	Bhp	Watts
1500	848	0.42	371	968	0.55	486	1069	0.68	600	1158	0.80	715	1238	0.94	831
1600	887	0.49	433	1004	0.63	556	1103	0.76	678	1190	0.90	800	1269	1.04	922
1700	927	0.57	502	1040	0.71	633	1137	0.86	763	1223	1.00	892	1302	1.15	1022
1800	967	0.65	579	1077	0.81	718	1172	0.96	856	1257	1.12	993	1334	1.27	1130
1900	1007	0.75	663	1115	0.91	811	1208	1.08	957	1291	1.24	1101	—	—	—
2000	1048	0.85	757	1153	1.03	913	1244	1.20	1066	—	—	—	—	—	—
2100	1090	0.97	859	1191	1.15	1023	—	—	—	—	—	—	—	—	—
2200	1131	1.09	970	1230	1.29	1143	—	—	—	—	—	—	—	—	—
2300	1173	1.23	1091	—	—	—	—	—	—	—	—	—	—	—	—
2400	—	—	—	—	—	—	—	—	—	—	—	—	—	—	—
2500	—	—	—	—	—	—	—	—	—	—	—	—	—	—	—

AIRFLOW CFM	EXTERNAL STATIC PRESSURE (in. wg)														
	1.2			1.4			1.6			1.8			2.0		
	Rpm	Bhp	Watts	Rpm	Bhp	Watts	Rpm	Bhp	Watts	Rpm	Bhp	Watts	Rpm	Bhp	Watts
1500	1312	1.07	948	1380	1.20	1067	—	—	—	—	—	—	—	—	—
1600	1342	1.18	1047	—	—	—	—	—	—	—	—	—	—	—	—
1700	1374	1.30	1153	—	—	—	—	—	—	—	—	—	—	—	—
1800	—	—	—	—	—	—	—	—	—	—	—	—	—	—	—
1900	—	—	—	—	—	—	—	—	—	—	—	—	—	—	—
2000	—	—	—	—	—	—	—	—	—	—	—	—	—	—	—
2100	—	—	—	—	—	—	—	—	—	—	—	—	—	—	—
2200	—	—	—	—	—	—	—	—	—	—	—	—	—	—	—
2300	—	—	—	—	—	—	—	—	—	—	—	—	—	—	—
2400	—	—	—	—	—	—	—	—	—	—	—	—	—	—	—
2500	—	—	—	—	—	—	—	—	—	—	—	—	—	—	—

NOTES:

1. Grey cells indicate field-supplied drive is required.
2. Maximum continuous bhp is 1.30.
3. See general fan performance notes.

LEGEND

**Bhp** — Brake Horsepower  
**Watts** — Input Watts to Motor

\*Motor drive range: 1035 to 1460 rpm. All other rpms require field-supplied drive.

48HE, HJ

Table 22—Fan Performance 48HJ006, 48HE006 Three-Phase — Vertical Discharge Units;  
Standard Motor (Belt Drive)\*

AIRFLOW CFM	EXTERNAL STATIC PRESSURE (in. wg)														
	0.2			0.4			0.6			0.8			1.0		
	Rpm	Bhp	Watts	Rpm	Bhp	Watts	Rpm	Bhp	Watts	Rpm	Bhp	Watts	Rpm	Bhp	Watts
1500	848	0.42	371	968	0.55	486	1069	0.68	600	1158	0.80	715	1238	0.94	831
1600	887	0.49	433	1004	0.63	556	1103	0.76	678	1190	0.90	800	1269	1.04	922
1700	927	0.57	502	1040	0.71	633	1137	0.86	763	1223	1.00	892	1302	1.15	1022
1800	967	0.65	579	1077	0.81	718	1172	0.96	856	1257	1.12	993	1334	1.27	1130
1900	1007	0.75	663	1115	0.91	811	1208	1.08	957	1291	1.24	1101	1368	1.40	1246
2000	1048	0.85	757	1153	1.03	913	1244	1.20	1066	1326	1.37	1219	1401	1.54	1371
2100	1090	0.97	859	1191	1.15	1023	1281	1.33	1185	1361	1.51	1345	1435	1.69	1505
2200	1131	1.09	970	1230	1.29	1143	1318	1.48	1313	1397	1.67	1481	1470	1.86	1649
2300	1173	1.23	1091	1269	1.43	1273	1355	1.63	1451	1433	1.83	1627	1505	2.03	1803
2400	1215	1.38	1223	1309	1.59	1413	1393	1.80	1600	1470	2.01	1784	1540	2.21	1967
2500	1258	1.54	1365	1349	1.76	1564	1431	1.98	1759	1506	2.20	1951	—	—	—

48HE\_HJ

AIRFLOW CFM	EXTERNAL STATIC PRESSURE (in. wg)														
	1.2			1.4			1.6			1.8			2.0		
	Rpm	Bhp	Watts	Rpm	Bhp	Watts	Rpm	Bhp	Watts	Rpm	Bhp	Watts	Rpm	Bhp	Watts
1500	1312	1.07	948	1380	1.20	1067	1445	1.34	1189	1506	1.48	1312	1564	1.62	1437
1600	1342	1.18	1047	1411	1.32	1173	1474	1.46	1300	1535	1.61	1429	1593	1.76	1560
1700	1374	1.30	1153	1441	1.45	1286	1505	1.60	1420	1565	1.75	1555	1622	1.91	1692
1800	1406	1.43	1268	1473	1.58	1407	1535	1.74	1548	1595	1.90	1690	1652	2.06	1833
1900	1438	1.57	1391	1504	1.73	1537	1567	1.90	1685	1626	2.06	1833	1682	2.23	1983
2000	1471	1.72	1523	1536	1.89	1677	1598	2.06	1831	1657	2.24	1986	—	—	—
2100	1504	1.87	1665	1569	2.06	1825	1630	2.24	1986	—	—	—	—	—	—
2200	1538	2.04	1816	1602	2.23	1984	—	—	—	—	—	—	—	—	—
2300	1572	2.23	1978	—	—	—	—	—	—	—	—	—	—	—	—
2400	—	—	—	—	—	—	—	—	—	—	—	—	—	—	—
2500	—	—	—	—	—	—	—	—	—	—	—	—	—	—	—

NOTES:

1. Grey cells indicate field-supplied drive is required.
2. Maximum continuous bhp is 2.40.
3. See general fan performance notes.

LEGEND

**Bhp** — Brake Horsepower  
**Watts** — Input Watts to Motor

\*Motor drive range: 1035 to 1460 rpm. All other rpms require field-supplied drive.

Table 23— Fan Performance 48HJ006, 48HE006 — Vertical Discharge Units; High-Static Motor (Belt Drive)\*

AIRFLOW CFM	EXTERNAL STATIC PRESSURE (in. wg)														
	0.2			0.4			0.6			0.8			1.0		
	Rpm	Bhp	Watts	Rpm	Bhp	Watts	Rpm	Bhp	Watts	Rpm	Bhp	Watts	Rpm	Bhp	Watts
1500	848	0.42	371	968	0.55	486	1069	0.68	600	1158	0.80	715	1238	0.94	831
1600	887	0.49	433	1004	0.63	556	1103	0.76	678	1190	0.90	800	1269	1.04	922
1700	927	0.57	502	1040	0.71	633	1137	0.86	763	1223	1.00	892	1302	1.15	1022
1800	967	0.65	579	1077	0.81	718	1172	0.96	856	1257	1.12	993	1334	1.27	1130
1900	1007	0.75	663	1115	0.91	811	1208	1.08	957	1291	1.24	1101	1368	1.40	1246
2000	1048	0.85	757	1153	1.03	913	1244	1.20	1066	1326	1.37	1219	1401	1.54	1371
2100	1090	0.97	859	1191	1.15	1023	1281	1.33	1185	1361	1.51	1345	1435	1.69	1505
2200	1131	1.09	970	1230	1.29	1143	1318	1.48	1313	1397	1.67	1481	1470	1.86	1649
2300	1173	1.23	1091	1269	1.43	1273	1355	1.63	1451	1433	1.83	1627	1505	2.03	1803
2400	1215	1.38	1223	1309	1.59	1413	1393	1.80	1600	1470	2.01	1784	1540	2.21	1967
2500	1258	1.54	1365	1349	1.76	1564	1431	1.98	1759	1506	2.20	1951	1576	2.41	2142

AIRFLOW CFM	EXTERNAL STATIC PRESSURE (in. wg)														
	1.2			1.4			1.6			1.8			2.0		
	Rpm	Bhp	Watts	Rpm	Bhp	Watts	Rpm	Bhp	Watts	Rpm	Bhp	Watts	Rpm	Bhp	Watts
1500	1312	1.07	948	1380	1.20	1067	1445	1.34	1189	1506	1.48	1312	1564	1.62	1437
1600	1342	1.18	1047	1411	1.32	1173	1474	1.46	1300	1535	1.61	1429	1593	1.76	1560
1700	1374	1.30	1153	1441	1.45	1286	1505	1.60	1420	1565	1.75	1555	1622	1.91	1692
1800	1406	1.43	1268	1473	1.58	1407	1535	1.74	1548	1595	1.90	1690	1652	2.06	1833
1900	1438	1.57	1391	1504	1.73	1537	1567	1.90	1685	1626	2.06	1833	1682	2.23	1983
2000	1471	1.72	1523	1536	1.89	1677	1598	2.06	1831	1657	2.24	1986	1713	2.41	2142
2100	1504	1.87	1665	1569	2.06	1825	1630	2.24	1986	1688	2.42	2149	1744	2.60	2312
2200	1538	2.04	1816	1602	2.23	1984	1663	2.42	2152	1720	2.61	2321	1775	2.81	2491
2300	1572	2.23	1978	1635	2.42	2153	1695	2.62	2328	1753	2.82	2504	—	—	—
2400	1607	2.42	2150	1669	2.63	2332	1729	2.83	2515	—	—	—	—	—	—
2500	1642	2.63	2333	1704	2.84	2523	—	—	—	—	—	—	—	—	—

NOTES:

1. Grey cells indicate field-supplied drive is required.
2. Maximum continuous bhp is 2.90.
3. See general fan performance notes.

LEGEND

**Bhp** — Brake Horsepower  
**Watts** — Input Watts to Motor

\*Motor drive range: 1300 to 1685 rpm. All other rpms require field-supplied drive.

Table 24—Fan Performance 48HJ007 — Vertical Discharge Units; Standard Motor (Belt Drive)\*

AIRFLOW CFM	EXTERNAL STATIC PRESSURE (in. wg)														
	0.2			0.4			0.6			0.8			1.0		
	Rpm	Bhp	Watts	Rpm	Bhp	Watts	Rpm	Bhp	Watts	Rpm	Bhp	Watts	Rpm	Bhp	Watts
1800	967	0.63	563	1075	0.80	715	1170	0.97	861	1255	1.13	1002	1333	1.28	1139
1900	1008	0.72	643	1112	0.91	805	1205	1.08	960	1289	1.25	1111	1366	1.42	1258
2000	1049	0.82	731	1151	1.02	903	1241	1.20	1068	1323	1.38	1228	1399	1.56	1384
2100	1091	0.93	827	1189	1.14	1008	1278	1.33	1183	1358	1.52	1353	1433	1.71	1519
2200	1133	1.05	933	1229	1.26	1123	1315	1.47	1308	1393	1.67	1487	1467	1.87	1662
2300	1176	1.18	1047	1268	1.40	1247	1352	1.62	1441	1429	1.84	1630	1501	2.04	1815
2400	1218	1.32	1170	1308	1.55	1380	1390	1.78	1584	1466	2.01	1782	1537	2.23	1977
2500	1261	1.47	1304	1349	1.72	1523	1429	1.96	1736	1503	2.19	1945	—	—	—
2600	1305	1.63	1448	1390	1.89	1677	1468	2.14	1900	1540	2.38	2117	—	—	—
2700	1348	1.80	1602	1431	2.07	1841	1507	2.33	2073	—	—	—	—	—	—
2800	1392	1.99	1768	1472	2.27	2016	—	—	—	—	—	—	—	—	—
2900	1435	2.19	1945	—	—	—	—	—	—	—	—	—	—	—	—
3000	1479	2.40	2135	—	—	—	—	—	—	—	—	—	—	—	—

AIRFLOW CFM	EXTERNAL STATIC PRESSURE (in. wg)														
	1.2			1.4			1.6			1.8			2.0		
	Rpm	Bhp	Watts	Rpm	Bhp	Watts	Rpm	Bhp	Watts	Rpm	Bhp	Watts	Rpm	Bhp	Watts
1800	1406	1.43	1273	1475	1.58	1403	1540	1.72	1531	1601	1.87	1657	1660	2.00	1780
1900	1438	1.58	1401	1505	1.73	1541	1569	1.89	1678	1630	2.04	1813	1689	2.19	1945
2000	1470	1.73	1537	1537	1.90	1686	1600	2.06	1833	1660	2.23	1977	1718	2.38	2118
2100	1502	1.89	1681	1568	2.07	1840	1631	2.25	1996	—	—	—	—	—	—
2200	1535	2.06	1834	1600	2.25	2002	—	—	—	—	—	—	—	—	—
2300	1569	2.25	1996	—	—	—	—	—	—	—	—	—	—	—	—
2400	—	—	—	—	—	—	—	—	—	—	—	—	—	—	—
2500	—	—	—	—	—	—	—	—	—	—	—	—	—	—	—
2600	—	—	—	—	—	—	—	—	—	—	—	—	—	—	—
2700	—	—	—	—	—	—	—	—	—	—	—	—	—	—	—
2800	—	—	—	—	—	—	—	—	—	—	—	—	—	—	—
2900	—	—	—	—	—	—	—	—	—	—	—	—	—	—	—
3000	—	—	—	—	—	—	—	—	—	—	—	—	—	—	—

NOTES:

1. Grey cells indicate field-supplied drive is required.
2. Maximum continuous bhp is 2.40.
3. See general fan performance notes.

LEGEND

**Bhp** — Brake Horsepower  
**Watts** — Input Watts to Motor

\*Motor drive range: 1119 to 1585 rpm. All other rpms require field-supplied drive.

48HE,HJ

Table 25—Fan Performance 48HJ007 — Vertical Discharge Units; High-Static Motor (Belt Drive)\*

AIRFLOW CFM	EXTERNAL STATIC PRESSURE (in. wg)														
	0.2			0.4			0.6			0.8			1.0		
	Rpm	Bhp	Watts	Rpm	Bhp	Watts	Rpm	Bhp	Watts	Rpm	Bhp	Watts	Rpm	Bhp	Watts
1800	967	0.63	563	1075	0.80	715	1170	0.97	861	1255	1.13	1002	1333	1.28	1139
1900	1008	0.72	643	1112	0.91	805	1205	1.08	960	1289	1.25	1111	1366	1.42	1258
2000	1049	0.82	731	1151	1.02	903	1241	1.20	1068	1323	1.38	1228	1399	1.56	1384
2100	1091	0.93	827	1189	1.14	1008	1278	1.33	1183	1358	1.52	1353	1433	1.71	1519
2200	1133	1.05	933	1229	1.26	1123	1315	1.47	1308	1393	1.67	1487	1467	1.87	1662
2300	1176	1.18	1047	1268	1.40	1247	1352	1.62	1441	1429	1.84	1630	1501	2.04	1815
2400	1218	1.32	1170	1308	1.55	1380	1390	1.78	1584	1466	2.01	1782	1537	2.23	1977
2500	1261	1.47	1304	1349	1.72	1523	1429	1.96	1736	1503	2.19	1945	1572	2.42	2149
2600	1305	1.63	1448	1390	1.89	1677	1468	2.14	1900	1540	2.38	2117	1608	2.62	2331
2700	1348	1.80	1602	1431	2.07	1841	1507	2.33	2073	1578	2.59	2301	1645	2.84	2524
2800	1392	1.99	1768	1472	2.27	2016	1547	2.54	2258	1616	2.81	2495	—	—	—
2900	1435	2.19	1945	1514	2.48	2203	1587	2.76	2455	—	—	—	—	—	—
3000	1479	2.40	2135	1556	2.70	2402	—	—	—	—	—	—	—	—	—

48HE,HJ

AIRFLOW CFM	EXTERNAL STATIC PRESSURE (in. wg)														
	1.2			1.4			1.6			1.8			2.0		
	Rpm	Bhp	Watts	Rpm	Bhp	Watts	Rpm	Bhp	Watts	Rpm	Bhp	Watts	Rpm	Bhp	Watts
1800	1406	1.43	1273	1475	1.58	1403	1540	1.72	1531	1601	1.87	1657	1660	2.00	1780
1900	1438	1.58	1401	1505	1.73	1541	1569	1.89	1678	1630	2.04	1813	1689	2.19	1945
2000	1470	1.73	1537	1537	1.90	1686	1600	2.06	1833	1660	2.23	1977	1718	2.38	2118
2100	1502	1.89	1681	1568	2.07	1840	1631	2.25	1996	1690	2.42	2149	1747	2.59	2300
2200	1535	2.06	1834	1600	2.25	2002	1662	2.44	2167	1721	2.62	2330	1778	2.80	2490
2300	1569	2.25	1996	1633	2.45	2174	1694	2.64	2348	1752	2.84	2520	—	—	—
2400	1603	2.44	2167	1666	2.65	2355	1727	2.86	2539	—	—	—	—	—	—
2500	1638	2.64	2349	1700	2.87	2546	—	—	—	—	—	—	—	—	—
2600	1673	2.86	2541	—	—	—	—	—	—	—	—	—	—	—	—
2700	—	—	—	—	—	—	—	—	—	—	—	—	—	—	—
2800	—	—	—	—	—	—	—	—	—	—	—	—	—	—	—
2900	—	—	—	—	—	—	—	—	—	—	—	—	—	—	—
3000	—	—	—	—	—	—	—	—	—	—	—	—	—	—	—

NOTES:

1. Grey cells indicate field-supplied drive is required.
2. Maximum continuous bhp is 2.90.
3. See general fan performance notes.

LEGEND

- Bhp** — Brake Horsepower  
**Watts** — Input Watts to Motor  
 \*Motor drive range: 1300 to 1685 rpm. All other rpms require field-supplied drive.

Table 26—Fan Performance 48HE003 — Horizontal Discharge Units; Standard Motor (Belt Drive)\*\*

AIRFLOW (Cfm)	EXTERNAL STATIC PRESSURE (in. wg)											
	0.1		0.2		0.4		0.6		0.8		1.0	
	Rpm	Bhp	Rpm	Bhp	Rpm	Bhp	Rpm	Bhp	Rpm	Bhp	Rpm	Bhp
600	490	0.08	521	0.08	597	0.14	703	0.21	788	0.29	868	0.37
700	519	0.09	557	0.09	623	0.16	729	0.24	816	0.32	892	0.41
800	537	0.1	582	0.12	650	0.19	751	0.27	845	0.37	927	0.47
900	560	0.13	610	0.14	681	0.22	783	0.32	870	0.42	947	0.53
1000	589	0.15	640	0.16	707	0.26	808	0.36	894	0.47	971	0.58

Table 27—Fan Performance 48HJ004, 48HE004 — Horizontal Discharge Units; Standard Motor  
(Belt Drive)\*

AIRFLOW CFM	EXTERNAL STATIC PRESSURE (in. wg)														
	0.2			0.4			0.6			0.8			1.0		
	Rpm	Bhp	Watts	Rpm	Bhp	Watts	Rpm	Bhp	Watts	Rpm	Bhp	Watts	Rpm	Bhp	Watts
900	553	0.14	134	681	0.22	221	782	0.32	316	870	0.42	417	948	0.53	526
1000	582	0.16	163	707	0.26	257	807	0.36	358	894	0.47	466	971	0.58	580
1100	612	0.20	196	734	0.30	297	833	0.41	405	919	0.52	519	995	0.64	639
1200	643	0.23	234	762	0.34	343	859	0.46	458	944	0.58	579	1020	0.71	705
1300	675	0.28	277	790	0.40	394	886	0.52	517	969	0.65	644	1044	0.78	777
1400	707	0.33	326	819	0.45	452	913	0.58	581	996	0.72	716	1070	0.86	855
1500	740	0.38	382	849	0.52	515	941	0.66	653	1023	0.80	795	1096	0.95	941

AIRFLOW CFM	EXTERNAL STATIC PRESSURE (in. wg)														
	1.2			1.4			1.6			1.8			2.0		
	Rpm	Bhp	Watts	Rpm	Bhp	Watts	Rpm	Bhp	Watts	Rpm	Bhp	Watts	Rpm	Bhp	Watts
900	1019	0.64	640	1084	0.76	760	1146	0.89	885	1203	1.02	1016	1258	1.16	1152
1000	1042	0.70	700	1107	0.83	825	1168	0.96	956	1225	1.10	1091	—	—	—
1100	1065	0.77	765	1130	0.90	896	1190	1.04	1032	1247	1.18	1173	—	—	—
1200	1089	0.84	837	1153	0.98	974	1213	1.12	1115	—	—	—	—	—	—
1300	1113	0.92	915	1177	1.06	1058	—	—	—	—	—	—	—	—	—
1400	1138	1.01	1000	1201	1.15	1149	—	—	—	—	—	—	—	—	—
1500	1163	1.10	1092	—	—	—	—	—	—	—	—	—	—	—	—

NOTES:

1. Grey cells indicate field-supplied drive is required.
2. Maximum continuous bhp is 1.20.
3. See general fan performance notes.

LEGEND

Bhp — Brake Horsepower  
Watts — Input Watts to Motor

\*Motor drive range: 680 to 1044 rpm. All other rpms require field-supplied drive.

Table 28—Fan Performance 48HJ004, 48HE004 — Horizontal Discharge Units; High-Static Motor  
(Belt Drive)\*

AIRFLOW CFM	EXTERNAL STATIC PRESSURE (in. wg)														
	0.2			0.4			0.6			0.8			1.0		
	Rpm	Bhp	Watts	Rpm	Bhp	Watts	Rpm	Bhp	Watts	Rpm	Bhp	Watts	Rpm	Bhp	Watts
900	553	0.14	134	681	0.22	221	782	0.32	316	870	0.42	417	948	0.53	526
1000	582	0.16	163	707	0.26	257	807	0.36	358	894	0.47	466	971	0.58	580
1100	612	0.20	196	734	0.30	297	833	0.41	405	919	0.52	519	995	0.64	639
1200	643	0.23	234	762	0.34	343	859	0.46	458	944	0.58	579	1020	0.71	705
1300	675	0.28	277	790	0.40	394	886	0.52	517	969	0.65	644	1044	0.78	777
1400	707	0.33	326	819	0.45	452	913	0.58	581	996	0.72	716	1070	0.86	855
1500	740	0.38	382	849	0.52	515	941	0.66	653	1023	0.80	795	1096	0.95	941

AIRFLOW CFM	EXTERNAL STATIC PRESSURE (in. wg)														
	1.2			1.4			1.6			1.8			2.0		
	Rpm	Bhp	Watts	Rpm	Bhp	Watts	Rpm	Bhp	Watts	Rpm	Bhp	Watts	Rpm	Bhp	Watts
900	1019	0.64	640	1084	0.76	760	1146	0.89	885	1203	1.02	1016	1258	1.16	1152
1000	1042	0.70	700	1107	0.83	825	1168	0.96	956	1225	1.10	1091	1279	1.24	1232
1100	1065	0.77	765	1130	0.90	896	1190	1.04	1032	1247	1.18	1173	1301	1.33	1319
1200	1089	0.84	837	1153	0.98	974	1213	1.12	1115	1270	1.27	1262	1324	1.42	1413
1300	1113	0.92	915	1177	1.06	1058	1237	1.21	1205	1293	1.36	1358	1347	1.52	1514
1400	1138	1.01	1000	1201	1.15	1149	1261	1.31	1303	1317	1.47	1461	1370	1.63	1623
1500	1163	1.10	1092	1226	1.25	1247	1285	1.41	1407	1341	1.58	1571	1394	1.75	1740

NOTES:

1. Grey cells indicate field-supplied drive is required.
2. Maximum continuous bhp is 2.40.
3. See general fan performance notes.

LEGEND

Bhp — Brake Horsepower  
Watts — Input Watts to Motor

\*Motor drive range: 1075 to 1455 rpm. All other rpms require field-supplied drive.

48HE, HJ

**Table 29—Fan Performance 48HJ005, 48HE005 — Horizontal Discharge Units; Standard Motor  
(Belt Drive)\***

AIRFLOW CFM	EXTERNAL STATIC PRESSURE (in. wg)														
	0.2			0.4			0.6			0.8			1.0		
	Rpm	Bhp	Watts	Rpm	Bhp	Watts	Rpm	Bhp	Watts	Rpm	Bhp	Watts	Rpm	Bhp	Watts
1200	643	0.23	234	762	0.34	343	859	0.46	458	944	0.58	579	1020	0.71	705
1300	675	0.28	277	790	0.40	394	886	0.52	517	969	0.65	644	1044	0.78	777
1400	707	0.33	326	819	0.45	452	913	0.58	581	996	0.72	716	1070	0.86	855
1500	740	0.38	382	849	0.52	515	941	0.66	653	1023	0.80	795	1096	0.95	941
1600	773	0.45	444	879	0.59	586	970	0.73	731	1050	0.88	880	1123	1.04	1034
1700	807	0.52	513	910	0.67	663	999	0.82	817	1078	0.98	973	1150	1.14	1134
1800	841	0.59	589	942	0.75	749	1029	0.91	910	1106	1.08	1074	—	—	—
1900	875	0.68	674	974	0.85	842	1059	1.02	1012	1135	1.19	1184	—	—	—
2000	910	0.77	767	1006	0.95	944	1090	1.13	1122	—	—	—	—	—	—

**48HE, HJ**

AIRFLOW CFM	EXTERNAL STATIC PRESSURE (in. wg)														
	1.2			1.4			1.6			1.8			2.0		
	Rpm	Bhp	Watts	Rpm	Bhp	Watts	Rpm	Bhp	Watts	Rpm	Bhp	Watts	Rpm	Bhp	Watts
1200	1089	0.84	837	1153	0.98	974	1213	1.12	1115	—	—	—	—	—	—
1300	1113	0.92	915	1177	1.06	1058	—	—	—	—	—	—	—	—	—
1400	1138	1.01	1000	1201	1.15	1149	—	—	—	—	—	—	—	—	—
1500	1163	1.10	1092	—	—	—	—	—	—	—	—	—	—	—	—
1600	1189	1.20	1191	—	—	—	—	—	—	—	—	—	—	—	—
1700	—	—	—	—	—	—	—	—	—	—	—	—	—	—	—
1800	—	—	—	—	—	—	—	—	—	—	—	—	—	—	—
1900	—	—	—	—	—	—	—	—	—	—	—	—	—	—	—
2000	—	—	—	—	—	—	—	—	—	—	—	—	—	—	—

**NOTES:**

1. **Grey cells** indicate field-supplied drive is required.
2. Maximum continuous bhp is 1.20.
3. See general fan performance notes.

**LEGEND**

**Bhp** — Brake Horsepower  
**Watts** — Input Watts to Motor

\*Motor drive range: 770 to 1185 rpm. All other rpms require field-supplied drive.

**Table 30—Fan Performance 48HJ005, 48HE005 — Horizontal Discharge Units; High-Static Motor  
(Belt Drive)\***

AIRFLOW CFM	EXTERNAL STATIC PRESSURE (in. wg)														
	0.2			0.4			0.6			0.8			1.0		
	Rpm	Bhp	Watts	Rpm	Bhp	Watts	Rpm	Bhp	Watts	Rpm	Bhp	Watts	Rpm	Bhp	Watts
1200	643	0.23	234	762	0.34	343	859	0.46	458	944	0.58	579	1020	0.71	705
1300	675	0.28	277	790	0.40	394	886	0.52	517	969	0.65	644	1044	0.78	777
1400	707	0.33	326	819	0.45	452	913	0.58	581	996	0.72	716	1070	0.86	855
1500	740	0.38	382	849	0.52	515	941	0.66	653	1023	0.80	795	1096	0.95	941
1600	773	0.45	444	879	0.59	586	970	0.73	731	1050	0.88	880	1123	1.04	1034
1700	807	0.52	513	910	0.67	663	999	0.82	817	1078	0.98	973	1150	1.14	1134
1800	841	0.59	589	942	0.75	749	1029	0.91	910	1106	1.08	1074	1177	1.25	1242
1900	875	0.68	674	974	0.85	842	1059	1.02	1012	1135	1.19	1184	1205	1.37	1360
2000	910	0.77	767	1006	0.95	944	1090	1.13	1122	1165	1.31	1302	1234	1.49	1485

AIRFLOW CFM	EXTERNAL STATIC PRESSURE (in. wg)														
	1.2			1.4			1.6			1.8			2.0		
	Rpm	Bhp	Watts	Rpm	Bhp	Watts	Rpm	Bhp	Watts	Rpm	Bhp	Watts	Rpm	Bhp	Watts
1200	1089	0.84	837	1153	0.98	974	1213	1.12	1115	1270	1.27	1262	1324	1.42	1413
1300	1113	0.92	915	1177	1.06	1058	1237	1.21	1205	1293	1.36	1358	1347	1.52	1514
1400	1138	1.01	1000	1201	1.15	1149	1261	1.31	1303	1317	1.47	1461	1370	1.63	1623
1500	1163	1.10	1092	1226	1.25	1247	1285	1.41	1407	1341	1.58	1571	1394	1.75	1740
1600	1189	1.20	1191	1252	1.36	1353	1310	1.53	1520	1365	1.70	1690	1418	1.87	1865
1700	1216	1.31	1299	1277	1.48	1468	1335	1.65	1640	1390	1.83	1817	1442	2.01	1998
1800	1242	1.42	1414	1303	1.60	1590	1361	1.78	1770	1415	1.96	1953	1467	2.15	2140
1900	1270	1.55	1538	1330	1.73	1721	1387	1.92	1908	1441	2.11	2098	1493	2.30	2292
2000	1297	1.68	1672	1357	1.87	1862	1414	2.07	2055	1467	2.26	2252	—	—	—

**NOTES:**

1. **Grey cells** indicate field-supplied drive is required.
2. Maximum continuous bhp is 2.40.
3. See general fan performance notes.

**LEGEND**

**Bhp** — Brake Horsepower  
**Watts** — Input Watts to Motor

\*Motor drive range: 1075 to 1455 rpm. All other rpms require field-supplied drive.



**Table 31—Fan Performance 48HJ006, 48HE006 Single-Phase — Horizontal Discharge Units;  
Standard Motor (Belt Drive)\***

AIRFLOW CFM	EXTERNAL STATIC PRESSURE (in. wg)														
	0.2			0.4			0.6			0.8			1.0		
	Rpm	Bhp	Watts	Rpm	Bhp	Watts	Rpm	Bhp	Watts	Rpm	Bhp	Watts	Rpm	Bhp	Watts
1500	800	0.39	350	904	0.49	438	999	0.60	535	1087	0.72	640	1169	0.85	753
1600	839	0.46	412	938	0.57	505	1030	0.68	605	1115	0.80	714	1195	0.93	829
1700	879	0.54	483	974	0.65	580	1062	0.77	684	1144	0.90	796	1221	1.03	914
1800	919	0.63	561	1010	0.75	663	1095	0.87	771	1174	1.00	886	1250	1.14	1008
1900	960	0.73	648	1047	0.85	754	1129	0.98	867	1206	1.11	986	1279	1.25	1111
2000	1001	0.84	744	1085	0.96	855	1163	1.09	972	1238	1.23	1095	—	—	—
2100	1043	0.96	850	1123	1.09	965	1199	1.22	1086	—	—	—	—	—	—
2200	1085	1.09	966	1162	1.22	1086	—	—	—	—	—	—	—	—	—
2300	1127	1.23	1092	—	—	—	—	—	—	—	—	—	—	—	—
2400	—	—	—	—	—	—	—	—	—	—	—	—	—	—	—
2500	—	—	—	—	—	—	—	—	—	—	—	—	—	—	—

AIRFLOW CFM	EXTERNAL STATIC PRESSURE (in. wg)														
	1.2			1.4			1.6			1.8			2.0		
	Rpm	Bhp	Watts	Rpm	Bhp	Watts	Rpm	Bhp	Watts	Rpm	Bhp	Watts	Rpm	Bhp	Watts
1500	1247	0.98	873	1320	1.13	1002	1390	1.28	1137	—	—	—	—	—	—
1600	1270	1.07	952	1342	1.22	1083	—	—	—	—	—	—	—	—	—
1700	1295	1.17	1040	—	—	—	—	—	—	—	—	—	—	—	—
1800	1321	1.28	1137	—	—	—	—	—	—	—	—	—	—	—	—
1900	—	—	—	—	—	—	—	—	—	—	—	—	—	—	—
2000	—	—	—	—	—	—	—	—	—	—	—	—	—	—	—
2100	—	—	—	—	—	—	—	—	—	—	—	—	—	—	—
2200	—	—	—	—	—	—	—	—	—	—	—	—	—	—	—
2300	—	—	—	—	—	—	—	—	—	—	—	—	—	—	—
2400	—	—	—	—	—	—	—	—	—	—	—	—	—	—	—
2500	—	—	—	—	—	—	—	—	—	—	—	—	—	—	—

**NOTES:**

1. **Grey cells** indicate field-supplied drive is required.
2. Maximum continuous bhp is 1.30.
3. See general fan performance notes.

**LEGEND**

**Bhp** — Brake Horsepower  
**Watts** — Input Watts to Motor

\*Motor drive range: 1035 to 1460 rpm. All other rpms require field-supplied drive.

**48HE, HJ**

**Table 32—Fan Performance 48HJ006, 48HE006 Three-Phase — Horizontal Discharge Units;  
Standard Motor (Belt Drive)\***

AIRFLOW CFM	EXTERNAL STATIC PRESSURE (in. wg)														
	0.2			0.4			0.6			0.8			1.0		
	Rpm	Bhp	Watts	Rpm	Bhp	Watts	Rpm	Bhp	Watts	Rpm	Bhp	Watts	Rpm	Bhp	Watts
1500	800	0.39	350	904	0.49	438	999	0.60	535	1087	0.72	640	1169	0.85	753
1600	839	0.46	412	938	0.57	505	1030	0.68	605	1115	0.80	714	1195	0.93	829
1700	879	0.54	483	974	0.65	580	1062	0.77	684	1144	0.90	796	1221	1.03	914
1800	919	0.63	561	1010	0.75	663	1095	0.87	771	1174	1.00	886	1250	1.14	1008
1900	960	0.73	648	1047	0.85	754	1129	0.98	867	1206	1.11	986	1279	1.25	1111
2000	1001	0.84	744	1085	0.96	855	1163	1.09	972	1238	1.23	1095	1309	1.38	1224
2100	1043	0.96	850	1123	1.09	965	1199	1.22	1086	1271	1.37	1213	1340	1.52	1346
2200	1085	1.09	966	1162	1.22	1086	1235	1.36	1211	1305	1.51	1342	1372	1.67	1479
2300	1127	1.23	1092	1201	1.37	1217	1272	1.52	1347	1340	1.67	1482	1405	1.83	1623
2400	1169	1.38	1229	1241	1.53	1359	1310	1.68	1493	1375	1.84	1633	1439	2.00	1778
2500	1212	1.55	1378	1281	1.70	1513	1348	1.86	1652	1412	2.02	1796	1473	2.19	1945

**48HE, HJ**

AIRFLOW CFM	EXTERNAL STATIC PRESSURE (in. wg)														
	1.2			1.4			1.6			1.8			2.0		
	Rpm	Bhp	Watts	Rpm	Bhp	Watts	Rpm	Bhp	Watts	Rpm	Bhp	Watts	Rpm	Bhp	Watts
1500	1247	0.98	873	1320	1.13	1002	1390	1.28	1137	1457	1.44	1280	1522	1.61	1430
1600	1270	1.07	952	1342	1.22	1083	1411	1.37	1221	1476	1.54	1365	1540	1.71	1517
1700	1295	1.17	1040	1365	1.32	1173	1432	1.48	1313	1497	1.64	1459	1559	1.82	1612
1800	1321	1.28	1137	1390	1.43	1273	1455	1.59	1415	1518	1.76	1563	1579	1.93	1718
1900	1348	1.40	1243	1415	1.56	1381	1479	1.72	1526	1541	1.89	1677	1601	2.06	1834
2000	1377	1.53	1359	1442	1.69	1500	1505	1.86	1648	1565	2.03	1801	1624	2.21	1961
2100	1406	1.67	1485	1470	1.83	1629	1531	2.00	1780	1591	2.18	1936	1648	2.36	2098
2200	1437	1.83	1621	1499	1.99	1769	1559	2.16	1923	1617	2.34	2082	—	—	—
2300	1468	1.99	1769	1529	2.16	1920	1587	2.34	2077	—	—	—	—	—	—
2400	1500	2.17	1928	1559	2.35	2083	—	—	—	—	—	—	—	—	—
2500	1533	2.36	2098	—	—	—	—	—	—	—	—	—	—	—	—

**NOTES:**

1. **Grey cells** indicate field-supplied drive is required.
2. Maximum continuous bhp is 2.40.
3. See general fan performance notes.

**LEGEND**

- Bhp** — Brake Horsepower  
**Watts** — Input Watts to Motor  
 \*Motor drive range: 1035 to 1460 rpm. All other rpms require field-supplied drive.

**Table 33—Fan Performance 48HJ006, 48HE006 — Horizontal Discharge Units; High-Static Motor (Belt Drive)\***

AIRFLOW CFM	EXTERNAL STATIC PRESSURE (in. wg)														
	0.2			0.4			0.6			0.8			1.0		
	Rpm	Bhp	Watts	Rpm	Bhp	Watts	Rpm	Bhp	Watts	Rpm	Bhp	Watts	Rpm	Bhp	Watts
1500	800	0.39	350	904	0.49	438	999	0.60	535	1087	0.72	640	1169	0.85	753
1600	839	0.46	412	938	0.57	505	1030	0.68	605	1115	0.80	714	1195	0.93	829
1700	879	0.54	483	974	0.65	580	1062	0.77	684	1144	0.90	796	1221	1.03	914
1800	919	0.63	561	1010	0.75	663	1095	0.87	771	1174	1.00	886	1250	1.14	1008
1900	960	0.73	648	1047	0.85	754	1129	0.98	867	1206	1.11	986	1279	1.25	1111
2000	1001	0.84	744	1085	0.96	855	1163	1.09	972	1238	1.23	1095	1309	1.38	1224
2100	1043	0.96	850	1123	1.09	965	1199	1.22	1086	1271	1.37	1213	1340	1.52	1346
2200	1085	1.09	966	1162	1.22	1086	1235	1.36	1211	1305	1.51	1342	1372	1.67	1479
2300	1127	1.23	1092	1201	1.37	1217	1272	1.52	1347	1340	1.67	1482	1405	1.83	1623
2400	1169	1.38	1229	1241	1.53	1359	1310	1.68	1493	1375	1.84	1633	1439	2.00	1778
2500	1212	1.55	1378	1281	1.70	1513	1348	1.86	1652	1412	2.02	1796	1473	2.19	1945

AIRFLOW CFM	EXTERNAL STATIC PRESSURE (in. wg)														
	1.2			1.4			1.6			1.8			2.0		
	Rpm	Bhp	Watts	Rpm	Bhp	Watts	Rpm	Bhp	Watts	Rpm	Bhp	Watts	Rpm	Bhp	Watts
1500	1247	0.98	873	1320	1.13	1002	1390	1.28	1137	1457	1.44	1280	1522	1.61	1430
1600	1270	1.07	952	1342	1.22	1083	1411	1.37	1221	1476	1.54	1365	1540	1.71	1517
1700	1295	1.17	1040	1365	1.32	1173	1432	1.48	1313	1497	1.64	1459	1559	1.82	1612
1800	1321	1.28	1137	1390	1.43	1273	1455	1.59	1415	1518	1.76	1563	1579	1.93	1718
1900	1348	1.40	1243	1415	1.56	1381	1479	1.72	1526	1541	1.89	1677	1601	2.06	1834
2000	1377	1.53	1359	1442	1.69	1500	1505	1.86	1648	1565	2.03	1801	1624	2.21	1961
2100	1406	1.67	1485	1470	1.83	1629	1531	2.00	1780	1591	2.18	1936	1648	2.36	2098
2200	1437	1.83	1621	1499	1.99	1769	1559	2.16	1923	1617	2.34	2082	1673	2.53	2246
2300	1468	1.99	1769	1529	2.16	1920	1587	2.34	2077	1644	2.52	2239	1699	2.71	2406
2400	1500	2.17	1928	1559	2.35	2083	1616	2.53	2243	1672	2.71	2408	1726	2.90	2579
2500	1533	2.36	2098	1591	2.54	2257	1647	2.73	2421	—	—	—	—	—	—

**NOTES:**

1. **Grey cells** indicate field-supplied drive is required.
2. Maximum continuous bhp is 2.90.
3. See general fan performance notes.

**LEGEND**

- Bhp** — Brake Horsepower  
**Watts** — Input Watts to Motor  
 \*Motor drive range: 1300 to 1685 rpm. All other rpms require field-supplied drive.

Table 34—Fan Performance 48HJ007 — Horizontal Discharge Units; Standard Motor (Belt Drive)\*

AIRFLOW CFM	EXTERNAL STATIC PRESSURE (in. wg)														
	0.2			0.4			0.6			0.8			1.0		
	Rpm	Bhp	Watts	Rpm	Bhp	Watts	Rpm	Bhp	Watts	Rpm	Bhp	Watts	Rpm	Bhp	Watts
1800	913	0.64	569	1010	0.80	715	1098	0.98	869	1178	1.16	1032	1252	1.35	1203
1900	952	0.73	652	1046	0.91	805	1131	1.09	965	1210	1.28	1134	1282	1.48	1311
2000	992	0.84	744	1083	1.02	903	1166	1.21	1070	1242	1.40	1245	1313	1.61	1427
2100	1032	0.95	844	1120	1.14	1010	1200	1.33	1184	1275	1.54	1365	1345	1.75	1553
2200	1073	1.07	954	1158	1.27	1127	1236	1.47	1307	1308	1.68	1495	1377	1.90	1689
2300	1114	1.21	1074	1196	1.41	1254	1272	1.62	1440	1343	1.84	1634	1409	2.07	1834
2400	1155	1.36	1204	1234	1.57	1391	1308	1.78	1584	1377	2.01	1784	1443	2.24	1990
2500	1196	1.51	1345	1273	1.73	1538	1345	1.96	1738	1412	2.19	1945	—	—	—
2600	1238	1.69	1497	1312	1.91	1697	1382	2.14	1904	1448	2.38	2117	—	—	—
2700	1280	1.87	1660	1352	2.10	1867	1420	2.34	2081	—	—	—	—	—	—
2800	1322	2.07	1835	1392	2.31	2050	—	—	—	—	—	—	—	—	—
2900	1364	2.28	2023	—	—	—	—	—	—	—	—	—	—	—	—
3000	—	—	—	—	—	—	—	—	—	—	—	—	—	—	—

AIRFLOW CFM	EXTERNAL STATIC PRESSURE (in. wg)														
	1.2			1.4			1.6			1.8			2.0		
	Rpm	Bhp	Watts	Rpm	Bhp	Watts	Rpm	Bhp	Watts	Rpm	Bhp	Watts	Rpm	Bhp	Watts
1800	1322	1.56	1382	1388	1.77	1568	1451	1.98	1762	1510	2.21	1962	—	—	—
1900	1351	1.68	1495	1416	1.90	1686	1477	2.12	1885	1536	2.35	2090	—	—	—
2000	1380	1.82	1617	1444	2.04	1814	1505	2.27	2017	—	—	—	—	—	—
2100	1411	1.97	1748	1473	2.20	1950	—	—	—	—	—	—	—	—	—
2200	1441	2.13	1890	1503	2.36	2097	—	—	—	—	—	—	—	—	—
2300	1473	2.30	2041	—	—	—	—	—	—	—	—	—	—	—	—
2400	—	—	—	—	—	—	—	—	—	—	—	—	—	—	—
2500	—	—	—	—	—	—	—	—	—	—	—	—	—	—	—
2600	—	—	—	—	—	—	—	—	—	—	—	—	—	—	—
2700	—	—	—	—	—	—	—	—	—	—	—	—	—	—	—
2800	—	—	—	—	—	—	—	—	—	—	—	—	—	—	—
2900	—	—	—	—	—	—	—	—	—	—	—	—	—	—	—
3000	—	—	—	—	—	—	—	—	—	—	—	—	—	—	—

NOTES:

1. Grey cells indicate field-supplied drive is required.
2. Maximum continuous bhp is 2.40.
3. See general fan performance notes.

LEGEND

**Bhp** — Brake Horsepower  
**Watts** — Input Watts to Motor

\*Motor drive range: 1119 to 1585 rpm. All other rpms require field-supplied drive.

48HE,HJ

Table 35—Fan Performance 48HJ007 — Horizontal Discharge Units; High-Static Motor (Belt Drive)\*

AIRFLOW CFM	EXTERNAL STATIC PRESSURE (in. wg)														
	0.2			0.4			0.6			0.8			1.0		
	Rpm	Bhp	Watts	Rpm	Bhp	Watts	Rpm	Bhp	Watts	Rpm	Bhp	Watts	Rpm	Bhp	Watts
1800	913	0.64	569	1010	0.80	715	1098	0.98	869	1178	1.16	1032	1252	1.35	1203
1900	952	0.73	652	1046	0.91	805	1131	1.09	965	1210	1.28	1134	1282	1.48	1311
2000	992	0.84	744	1083	1.02	903	1166	1.21	1070	1242	1.40	1245	1313	1.61	1427
2100	1032	0.95	844	1120	1.14	1010	1200	1.33	1184	1275	1.54	1365	1345	1.75	1553
2200	1073	1.07	954	1158	1.27	1127	1236	1.47	1307	1308	1.68	1495	1377	1.90	1689
2300	1114	1.21	1074	1196	1.41	1254	1272	1.62	1440	1343	1.84	1634	1409	2.07	1834
2400	1155	1.36	1204	1234	1.57	1391	1308	1.78	1584	1377	2.01	1784	1443	2.24	1990
2500	1196	1.51	1345	1273	1.73	1538	1345	1.96	1738	1412	2.19	1945	1477	2.43	2157
2600	1238	1.69	1497	1312	1.91	1697	1382	2.14	1904	1448	2.38	2117	1511	2.63	2335
2700	1280	1.87	1660	1352	2.10	1867	1420	2.34	2081	1484	2.59	2300	1546	2.84	2526
2800	1322	2.07	1835	1392	2.31	2050	1458	2.56	2270	1521	2.81	2496	—	—	—
2900	1364	2.28	2023	1432	2.53	2245	1496	2.78	2472	—	—	—	—	—	—
3000	1406	2.50	2224	1472	2.76	2452	—	—	—	—	—	—	—	—	—

48HE,HJ

AIRFLOW CFM	EXTERNAL STATIC PRESSURE (in. wg)														
	1.2			1.4			1.6			1.8			2.0		
	Rpm	Bhp	Watts	Rpm	Bhp	Watts	Rpm	Bhp	Watts	Rpm	Bhp	Watts	Rpm	Bhp	Watts
1800	1322	1.56	1382	1388	1.77	1568	1451	1.98	1762	1510	2.21	1962	1568	2.44	2169
1900	1351	1.68	1495	1416	1.90	1686	1477	2.12	1885	1536	2.35	2090	1593	2.59	2302
2000	1380	1.82	1617	1444	2.04	1814	1505	2.27	2017	1563	2.51	2227	1619	2.75	2443
2100	1411	1.97	1748	1473	2.20	1950	1533	2.43	2159	1590	2.67	2374	—	—	—
2200	1441	2.13	1890	1503	2.36	2097	1562	2.60	2311	1618	2.85	2532	—	—	—
2300	1473	2.30	2041	1533	2.54	2254	1591	2.79	2474	—	—	—	—	—	—
2400	1505	2.48	2203	1564	2.73	2422	—	—	—	—	—	—	—	—	—
2500	1537	2.68	2376	—	—	—	—	—	—	—	—	—	—	—	—
2600	1571	2.88	2560	—	—	—	—	—	—	—	—	—	—	—	—
2700	—	—	—	—	—	—	—	—	—	—	—	—	—	—	—
2800	—	—	—	—	—	—	—	—	—	—	—	—	—	—	—
2900	—	—	—	—	—	—	—	—	—	—	—	—	—	—	—
3000	—	—	—	—	—	—	—	—	—	—	—	—	—	—	—

NOTES:

1. Grey cells indicate field-supplied drive is required.
2. Maximum continuous bhp is 2.90.
3. See general fan performance notes.

LEGEND

- Bhp** — Brake Horsepower  
**Watts** — Input Watts to Motor  
 \*Motor drive range: 1300 to 1685 rpm. All other rpms require field-supplied drive.

Table 36—Accessory/FIOP EconoMi\$er IV and EconoMi\$er2 Static Pressure\* (in. wg)

COMPONENT	CFM							
	1250	1500	1750	2000	2250	2500	2750	3000
Vertical EconoMi\$er2 and EconoMi\$er IV	0.045	0.065	0.08	0.12	0.145	0.175	0.22	0.255
Horizontal EconoMi\$er2 and EconoMi\$er IV	—	—	0.1	0.125	0.15	0.18	0.225	0.275

LEGEND

FIOP — Factory-Installed Option

\*The static pressure must be added to external static pressure. The sum and the evaporator entering-air cfm should be used in conjunction with the Fan Performance tables to determine indoor blower rpm and watts.

## PRE-START-UP

### **WARNING**

#### **FIRE, EXPLOSION, ELECTRICAL SHOCK HAZARD**

Failure to follow this warning could result in personal injury, death and/or property damage:

1. Follow recognized safety practices and wear protective goggles when checking or servicing a refrigerant system.
2. Do not operate the compressor or provide any electric power to the unit unless the compressor terminal cover is in place and secured.
3. Do not remove the compressor terminal cover until all electrical sources are disconnected and tagged with lockout tags.
4. Relieve all pressure from the system before touching or disturbing anything inside the terminal box if a refrigerant leak is suspected around the compressor terminals. Use accepted methods to recover the refrigerant.
5. Never attempt to repair a soldered connection while the refrigerant system is under pressure.
6. Do not use a torch to remove any component. The system contains oil and refrigerant under pressure. To remove a component, wear protective goggles and proceed as follows:
  - a. Shut off electrical power to the unit and tag disconnect.
  - b. Recover refrigerant to relieve all pressure from the system using both high-pressure and low-pressure ports.
  - c. Cut component connection tubing with a tubing cutter, and remove the component from the unit.
  - d. Carefully unsweat the remaining tubing stubs when necessary. Oil can ignite when exposed to a torch flame.

Proceed as follows to inspect and prepare the unit for initial start-up:

1. Remove all access panels.
2. Read and follow instructions on all **WARNING**, **CAUTION**, and **INFORMATION** labels attached to, or shipped with, unit.
3. Make the following inspections:
  - a. Inspect for shipping and handling damages such as broken lines, loose parts, or disconnected wires, etc.
  - b. Inspect for oil at all refrigerant tubing connections and on unit base. Detecting oil generally indicates a refrigerant leak. Leak-test all refrigerant tubing connections using electronic leak detector, halide torch, or liquid-soap solution.
  - c. Inspect all field-wiring and factory-wiring connections. Be sure that connections are completed and tight. Be sure that wires are not in contact with refrigerant tubing or sharp edges.
  - d. Inspect coil fins. If damaged during shipping and handling, carefully straighten fins with a fin comb.
4. Verify the following conditions:
  - a. Make sure that condenser-fan blade are correctly positioned in fan orifice. See Condenser-Fan Adjustment section for more details.
  - b. Make sure that air filter(s) is in place.
  - c. Make sure that condensate drain trap is filled with water to ensure proper drainage.

- d. Make sure that all tools and miscellaneous loose parts have been removed.

## START-UP

### **Step 1 —Unit Preparation**

Make sure that the unit has been installed in accordance with installation instructions and applicable codes.

### **Step 2 —Gas Piping**

Check gas piping for leaks.

### **WARNING**

#### **ELECTRICAL SHOCK HAZARD**

Failure to follow this warning could cause personal injury or death.

Disconnect gas piping from unit when leak testing at pressure greater than  $\frac{1}{2}$  psig. Pressures greater than  $\frac{1}{2}$  psig will cause gas valve damage resulting in hazardous condition. If gas valve is subjected to pressure greater than  $\frac{1}{2}$  psig, it *must* be replaced before use. When pressure testing field-supplied gas piping at pressures of  $\frac{1}{2}$  psig or less, a unit connected to such piping must be isolated by manually closing the gas valve.

### **Step 3 —Return-Air Filters**

Make sure the correct filters are installed in the unit (See Table 1 or 2). Do not operate the unit without return-air filters.

### **Step 4 —Outdoor-Air Inlet Screens**

Outdoor-air inlet screen(s) must be in place before operating the unit.

### **Step 5 —Compressor Mounting**

Compressors are internally spring mounted. Do not loosen or remove the compressor holddown bolts.

### **Step 6 —Internal Wiring**

Check all electrical connections in unit control boxes; tighten them as required.

### **Step 7 —Refrigerant Service Ports**

Each unit system has 4 Schrader-type service ports: one on the suction line, one on the liquid line, and 2 on the compressor discharge line. Be sure that caps on the ports are tight. Two additional Schrader valves are located under the high-pressure and low-pressure switches, respectively.

### **Step 8 —High Flow Refrigerant Valves**

Two high flow valves are located on the hot gas tube coming out of the compressor and the suction tube going into the compressor. Large black plastic caps identify these valves. These valves have O-rings inside which screw the cap onto a brass body to prevent leaks. No field access to these valves is available at this time. Ensure the plastic caps remain on the valves and are tight or the possibility of refrigerant leakage could occur.

### **Step 9 —Compressor Rotation**

On 3-phase units be certain that the compressor is rotating in the proper direction. To determine whether or not compressor is rotating in the proper direction:

1. Connect the service gauges to suction and discharge pressure fittings.
2. Energize the compressor.
3. The suction pressure should drop and the discharge pressure should rise, as is normal on any start-up.

If the suction pressure does not drop and the discharge pressure does not rise to normal levels:

1. Note that the indoor fan (006 and 007 three-phase units only) is probably also rotating in the wrong direction.

2. Turn off power to the unit and tag disconnect.
3. Reverse any two of the unit power leads.
4. Turn on power to the unit and energize the compressor.

The suction and discharge pressure levels should now move to their normal start-up levels.

**NOTE:** When the compressor is rotating in the wrong direction, the unit makes more noise and does not provide cooling.

#### Step 10 —Cooling

Set the space thermostat to the OFF position. Set the system selector switch at COOL position and the fan switch at AUTO position. Adjust the thermostat to a setting below room temperature. The compressor starts when contactor closes.

Check the unit charge. Refer to Refrigerant Charge section.

Reset the thermostat at a position above room temperature. The compressor will shut off. Evaporator fan will shut off after a 30-second delay.

To Shut Off Unit - Set the system selector switch at OFF position. Resetting the thermostat at a position above room temperature shuts off the unit temporarily until the space temperature exceeds the thermostat setting. Units are equipped with a Cycle-LOC™ protection device. The unit shuts down on any safety trip and remains off; an indicator light on the thermostat comes on. Check the reason for the safety trip.

#### Step 11 —Main Burners

Main burners are factory set and should require no adjustment.

TO CHECK ignition of main burners and heating controls, move thermostat set point above room temperature and verify that the burners light and evaporator fan is energized. Check heating effect, then lower the thermostat setting below the room temperature and verify that the burners and evaporator fan turn off.

Refer to Tables 37 and 38 for the correct orifice to use at high altitudes.

**Table 37—Altitude Compensation\***  
48HJ004-007, 48HE003-006 Standard Units

ELEVATION (ft)	72,000 AND 115,000 BTUH NOMINAL INPUT		150,000 BTUH NOMINAL INPUT	
	Natural Gas Orifice Size†	Liquid Propane Orifice Size†	Natural Gas Orifice Size†	Liquid Propane Orifice Size†
0-2,000	33	43	30	37
2,000	36	44	31	39
3,000	36	45	31	40
4,000	37	45	32	41
5,000	38	46	32	42
6,000	40	47	34	43
7,000	41	48	35	43
8,000	42	49	36	44
9,000	43	50	37	45
10,000	44	50	39	46
11,000	45	51	41	47
12,000	46	52	42	48
13,000	47	52	43	49
14,000	48	53	44	50

\*As the height above sea level increases, there is less oxygen per cubic foot of air. Therefore, heat input rate should be reduced at higher altitudes.

†Orifices available through your Carrier distributor.

**Table 38—Altitude Compensation\* —**  
48HJ004-006, 48HE003-006 Low NOx Units

ELEVATION (ft)	60,000 AND 90,000 BTUH NOMINAL INPUT		120,000 BTUH NOMINAL INPUT	
	Natural Gas Orifice Size†	Liquid Propane Orifice Size†	Natural Gas Orifice Size	Liquid Propane Orifice Size†
0-2,000	38	45	32	42
2,000	40	47	33	43
3,000	41	48	35	43
4,000	42	49	36	44
5,000	43	49	37	45
6,000	43	50	38	45
7,000	44	50	39	46
8,000	45	51	41	47
9,000	46	52	42	48
10,000	47	52	43	49
11,000	48	53	44	50
12,000	49	53	44	51
13,000	50	54	46	52
14,000	51	54	47	52

\*As the height above sea level increases, there is less oxygen per cubic foot of air. Therefore, the input rate should be reduced at higher altitudes.

†Orifices are available through your local Carrier distributor.

#### Step 12 —Heating

1. Purge gas supply line of air by opening union ahead of the gas valve. If gas odor is detected, tighten union and wait 5 minutes before proceeding.
2. Turn on electrical supply and manual gas valve.
3. Set system switch selector at HEAT position and fan switch at AUTO or ON position. Set heating temperature lever above room temperature.
4. The induced-draft motor will start.
5. After a call for heating, the main burners should light within 5 seconds. If the burner does not light, then there is a 22-second delay before another 5-second try. If the burner still does not light, the time delay is repeated. If the burner does not light within 15 minutes, there is a lockout. To reset the control, break the 24 v power to W1.
6. The evaporator-fan motor will turn on 45 seconds after burner ignition.
7. The evaporator-fan motor will turn off in 45 seconds after the thermostat temperature is satisfied.
8. Adjust airflow to obtain a temperature rise within the range specified on the unit nameplate.

**NOTE:** The default value for the evaporator-fan motor on/off delay is 45 seconds. The Integrated Gas Unit Controller (IGC) modifies this value when abnormal limit switch cycles occur. Based upon unit operating conditions, the on delay can be reduced to 0 seconds and the off delay can be extended to 180 seconds. When one flash of the LED (light-emitting diode) is observed, the evaporator-fan on/off delay has been modified.

If the limit switch trips at the start of the heating cycle during the evaporator on delay, the time period of the on delay for the next cycle will be 5 seconds less than the time at which the switch tripped. (Example: If the limit switch trips at 30 seconds, the evaporator-fan on delay for the next cycle will occur at 25 seconds.) To prevent short-cycling, a 5-second reduction will only occur if a minimum of 10 minutes has elapsed since the last call for heating.

The evaporator-fan off delay can also be modified. Once the call for heating has ended, there is a 10-minute period during which the modification can occur. If the limit switch trips during this period, the evaporator-fan off delay will increase by 15 seconds.

48HE,HJ

A maximum of 9 trips can occur, extending the evaporator-fan off delay to 180 seconds.

To restore the original default value, reset the power to the unit.

To Shut Off Unit —Set system selector switch at off position. Resetting heating selector lever below room temperature will temporarily shut unit off until space temperature falls below thermostat setting.

### Step 13 —Safety Relief

A soft solder joint at the suction line fitting provides pressure relief under abnormal temperature and pressure conditions.

### Step 14 —Ventilation (Continuous Fan)

Set fan and system selector switches at ON and OFF positions, respectively. Evaporator fan operates continuously to provide constant air circulation. When the evaporator-fan selector switch is turned to the OFF position, there is a 30-second delay before the fan turns off.

### Step 15 —Operating Sequence

#### cooling - units without economizer

When thermostat calls for cooling, terminals G and Y1 are energized. The indoor-fan contactor (IFC), reversing valve solenoid (RVS) and compressor contactor are energized and indoor-fan motor, compressor, and outdoor fan starts. The outdoor fan motor runs continuously while unit is cooling.

#### heating - units without economizer

When the thermostat calls for heating, terminal W1 is energized. To prevent thermostat short-cycling, the unit is locked into the Heating mode for at least 1 minute when W1 is energized. The induced-draft motor is energized and the burner ignition sequence begins. The indoor (evaporator) fan motor (IFM) is energized 45 seconds after a flame is ignited. On units equipped for two stages of heat, when additional heat is needed, W2 is energized and the high-fire solenoid on the main gas valve (MGV) is energized. When the thermostat is satisfied and W1 is deenergized, the IFM stops after a 45-second time-off delay.

#### Cooling - units with economizer iv

When free cooling is not available, the compressors will be controlled by the zone thermostat. When free cooling is available, the outdoor-air damper is modulated by the EconoMiSer IV control to provide a 50° to 55°F supply-air temperature into the zone. As the supply-air temperature fluctuates above 55° or below 50°F, the dampers will be modulated (open or close) to bring the supply-air temperature back within the set point limits. Integrated EconoMiSer IV operation on single-stage units requires a 2-stage thermostat (Y1 and Y2).

For EconoMiSer IV operation, there must be a thermostat call for the fan (G). This will move the damper to its minimum position during the occupied mode.

If the increase in cooling capacity causes the supply-air temperature to drop below 45°F, then the outdoor-air damper position will be fully closed. If the supply-air temperature continues to fall, the outdoor-air damper will close. Control returns to normal once the supply-air temperature rises above 48°F.

If optional power exhaust is installed, as the outdoor-air damper opens and closes, the power exhaust fans will be energized and deenergized.

If field-installed accessory CO<sub>2</sub> sensors are connected to the EconoMiSer IV control, a demand controlled ventilation strategy will begin to operate. As the CO<sub>2</sub> level in the zone increases above the CO<sub>2</sub> set point, the minimum position of the damper will be increased proportionally. As the CO<sub>2</sub> level decreases because of the increase in fresh air, the outdoor-air damper will be proportionally closed. Damper position will follow the higher demand condition from DCV mode or free cooling mode.

Damper movement from full closed to full open (or vice versa) will take between 1-1/2 and 2-1/2 minutes.

If free cooling can be used as determined from the appropriate changeover command (switch, dry bulb, enthalpy curve, differential dry bulb, or differential enthalpy), a call for cooling (Y1 closes at the thermostat) will cause the control to modulate the dampers open to maintain the supply air temperature set point at 50° to 55° F.

As the supply air temperature drops below the set point range of 50° to 55° F, the control will modulate the outdoor-air dampers closed to maintain the proper supply-air temperature.

#### heating - units with economizer iv

When the room temperature calls for heat, the heating controls are energized as described in the Heating, Units Without Economizer section. When the thermostat is satisfied, the economizer damper moves to the minimum position.

#### cooling - units with economizer2, premierlink™ CONTROL AND A THERMOSTAT

When free cooling is not available, the compressors will be controlled by the PremierLink control in response to the Y1 and Y2 inputs from the thermostat.

The PremierLink control will use the following information to determine if free cooling is available:

- Indoor fan has been on for at least 30 seconds.
- The SPT, SAT, and OAT inputs must have valid readings.
- OAT must be less than 75°F.
- OAT must be less than SPT.
- Enthalpy must be LOW (may be jumpered if an enthalpy sensor not available).
- Economizer position is NOT forced.

Pre-cooling occurs when there is no call from the thermostat except G. Pre-cooling is defined as the economizer modulates to provide 70°F supply air.

When free cooling is available the PremierLink control will control the compressors and economizer to provide a supply-air temperature determined to meet the Y1 and Y2 calls from the thermostat using the following three routines. The three control routines are based on OAT.

The 3 routines are based on OAT where:

SASP = Supply Air Set Point

DXCTLO = Direct Expansion Cooling Lockout Set Point

PID = Proportional Integral

#### **Routine 1** (OAT < DXCTLO)

- Y1 energized – economizer maintains a SASP = (SATLO1 + 3).
- Y2 energized – economizer maintains a SASP = (SATLO2 + 3).

#### **Routine 2** (DXCTLO < OAT < 68°F)

- If only Y1 energized, the economizer maintains a SASP = (SATLO1 + 3).
- If SAT > SASP + 5 and economizer position > 80%, economizer will go to minimum position for 3 minutes or until SAT > 68°F.
- First stage of mechanical cooling will be energized.
- Integrator resets.
- Economizer opens again and controls to current SASP after stage one on for 90 seconds.
- With Y1 and Y2 energized Economizer maintains an SASP = SATLO2 + 3.

- If SAT > SASP + 5 and economizer position >80%, economizer will go to minimum position for 3 minutes or until SAT > 68°F.
- If compressor one is on then second stage of mechanical cooling will be energized; otherwise the first stage will be energized.
- Integrator resets.
- Economizer opens again and controls to SASP after stage one on for 90 seconds.

**Routine 3 (OAT > 68)**

- Economizer is opened 100%.
- Compressors 1 and 2 are cycled based on Y1 and Y2 using minimum on and off times and watching the supply air temperature as compared to SATLO1 and SATLO2 set points.

If optional power exhaust is installed, as the outdoor-air damper opens and closes, the power exhaust fans will be energized and deenergized.

If field-installed accessory CO<sub>2</sub> sensors are connected to the PremierLink™ control, a PID-controlled demand ventilation strategy will begin to operate. As the CO<sub>2</sub> level in the zone increases above the CO<sub>2</sub> set point, the minimum position of the damper will be increased proportionally. As the CO<sub>2</sub> level decreases because of the increase in fresh air, the outdoor-air damper will be proportionally closed.

**HEATING - UNITS WITH ECONOMISER2, PREMIER-LINK CONTROL AND A THERMOSTAT**

When the thermostat calls for heating, terminal W1 is energized. The PremierLink control will move the economizer damper to the minimum position if there is a call for G and closed if there is a call for W1 without G. In order to prevent thermostat from short cycling, the unit is locked into the heating mode for at least 10 minutes when W1 is energized. The induced-draft motor is then energized and the burner ignition sequence begins.

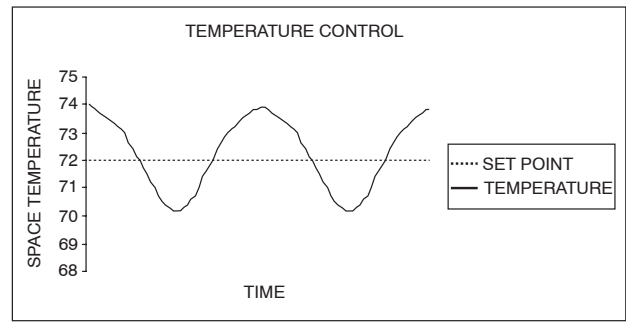
On units equipped for two stages of heat, when additional heat is needed, W2 is energized and the high-fire solenoid on the main gas valve (MGV) is energized. When the thermostat is satisfied and W1 is deenergized, the IFM stops after a 45-second time-off delay unless G is still maintained.

**COOLING - UNITS WITH ECONOMISER2, PREMIER-LINK CONTROL AND A ROOM SENSOR**

When free cooling is not available, the compressors will be controlled by the PremierLink controller using a PID Error reduction calculation as indicated by Fig 51.

The PremierLink controller will use the following information to determine if free cooling is available:

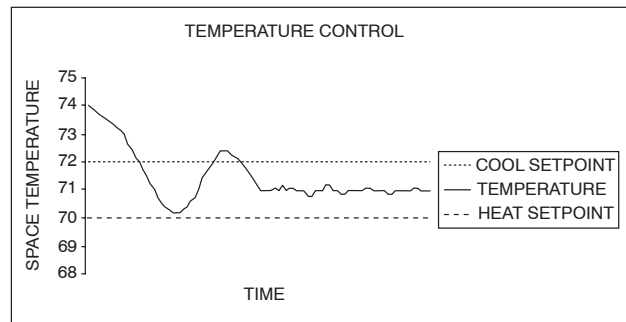
- Indoor fan has been on for at least 30 seconds.
- The SPT, SAT, and OAT inputs must have valid readings.
- OAT must be less than 75°F.
- OAT must be less than SPT.
- Enthalpy must be LOW (may be jumpered if an enthalpy sensor is not available).
- Economizer position is NOT forced.



NOTE: PremierLink control performs smart staging of 2 stages of DX cooling and up to 3 stages of heat.

C06042

**Fig. 51 – DX Cooling Temperature Control Example**



C06043

**Fig. 52 – Economizer Temperature Control Example**

When free cooling is available, the outdoor-air damper is positioned through the use of a Proportional Integral (PID) control process to provide a calculated supply-air temperature into the zone. The supply air will maintain the space temperature between the heating and cooling set points as indicated in Fig. 52. The PremierLink control will integrate the compressor stages with the economizer based on similar logic as the three routines listed in the previous section. The SASP will float up and down based on the error reduction calculations that compare space temperature and space set point.

When outside-air temperature conditions require the economizer to close for a compressor stage-up sequence, the economizer control integrator is reset to zero after the stage-up sequence is completed. This prevents the supply-air temperature from dropping too quickly and creating a freeze condition that would make the compressor turn off prematurely.

The high space set point is used for DX (direct expansion) cooling control, while the economizer space set point is a calculated value between the heating and cooling set points. The economizer set point will always be at least one degree below the cooling set point, allowing for a smooth transition from mechanical cooling with economizer assist, back to economizer cooling as the cooling set point is achieved. The compressors may be used for initial cooling then the PremierLink controller will modulate the economizer using an error reduction calculation to hold the space temperature between the heating and cooling set points. (See Fig. 52.)

The controller uses the following conditions to determine economizer cooling:

- Enthalpy is Low
- SAT reading is available
- OAT reading is available



- SPT reading is available
- $OAT \leq SPT$
- Economizer Position is NOT forced

If any of the above conditions are **not** met, the economizer submaster reference (ECSR) is set to maximum limit and the damper moves to minimum position. The operating sequence is complete. The ECSR is recalculated every 30 seconds.

If an optional power exhaust is installed, as the outdoor-air damper opens and closes, the power exhaust fans will be energized and deenergized.

If field-installed accessory CO<sub>2</sub> sensors are connected to the PremierLink™ control, a PID-controlled demand ventilation strategy will begin to operate. As the CO<sub>2</sub> level in the zone increases above the CO<sub>2</sub> set point, the minimum position of the damper will be increased proportionally. As the CO<sub>2</sub> level decreases because of the increase in fresh air, the outdoor-air damper will be proportionally closed.

### HEATING - UNIT WITH ECONOMIZER2, PREMIER-LINK CONTROL AND A ROOM SENSOR

Every 40 seconds the controller will calculate the required heat stages (maximum of 3) to maintain Supply-Air Temperature (SAT) if the following qualifying conditions are met:

- Indoor fan has been on for at least 30 seconds.
- COOL mode is not active.
- OCCUPIED, TEMP. COMPENSATED START or HEAT mode is active.
- SAT reading is available.
- Fire shutdown mode is not active.

If all of the above conditions are met, the number of heat stages is calculated; otherwise the required number of heat stages will be set to 0.

If the PremierLink controller determines that heat stages are required, the economizer damper will be moved to minimum position if occupied and closed if unoccupied.

Staging should be as follows:

If Heating PID STAGES=2

- HEAT STAGES=1 (50% capacity) will energize HS1
- HEAT STAGES=2 (100% capacity) will energize HS2

If Heating PID STAGES=3 and AUXOUT = HS3

- HEAT STAGES=1 (33% capacity) will energize HS1
- HEAT STAGES=2 (66% capacity) will energize HS2
- HEAT STAGES=3 (100% capacity) will energize HS3

In order to prevent short cycling, the unit is locked into the Heating mode for at least 10 minutes when HS1 is deenergized. When HS1 is energized the induced-draft motor is then energized and the burner ignition sequence begins. On units equipped for two stages of heat, when additional heat is needed, HS2 is energized and the high-fire solenoid on the main gas valve (MGV) is energized. When the space condition is satisfied and HS1 is deenergized the IFM stops after a 45-second time-off delay unless in the occupied mode. The fan will run continuously in the occupied mode as required by national energy and fresh air standards.

### UNITS WITH HUMIDI-MIZER™ ADAPTIVE DEHUMIDIFICATION SYSTEM

#### Normal Design Operation

When the rooftop operates under the normal sequence of operation, the compressors will cycle to maintain indoor conditions. (See Fig. 53.)

The Humidi-MiZer adaptive dehumidification system includes a factory-installed Motormaster® low ambient control to keep the

head and suction pressure high, allowing normal design cooling mode operation down to 0° F.

#### Subcooling Mode

When subcooling mode is initiated, this will energize (close) the liquid line solenoid valve (LLSV) forcing the hot liquid refrigerant to enter into the subcooling coil. (See Fig. 54.)

As the hot liquid refrigerant passes through the subcooling/ reheat dehumidification coil, it is exposed to the cold supply airflow coming through the evaporator coil. The liquid is further subcooled to a temperature approaching the evaporator leaving-air temperature. The liquid then enters a thermostatic expansion valve (TXV) where the liquid drops to a lower pressure. The TXV does not have a pressure drop great enough to change the liquid to a 2-phase fluid, so the liquid then enters the Acutrol™ device at the evaporator coil.

The liquid enters the evaporator coil at a temperature lower than in standard cooling operation. This lower temperature increases the latent capacity of the rooftop unit. The refrigerant passes through the evaporator and is turned into a vapor. The air passing over the evaporator coil will become colder than during normal operation. However, as this same air passes over the subcooling coil, it will be slightly warmed, partially reheating the air.

Subcooling mode operates only when the outside air temperature is warmer than 40°F. A factory-installed temperature switch located in the condenser section will lock out subcooling mode when the outside temperature is cooler than 40°F.

The scroll compressors are equipped with crankcase heaters to provide protection for the compressors due to the additional refrigerant charge required by the subcooling/reheat coil.

When in subcooling mode, there is a slight decrease in system total gross capacity (5% less), a lower gross sensible capacity (20% less), and a greatly increased latent capacity (up to 40% more).

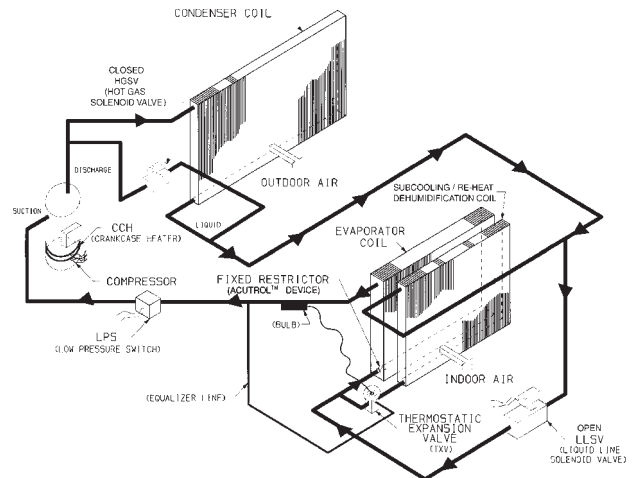


Fig. 53 – Humidi-MiZer Normal Design Cooling Operation

C06135

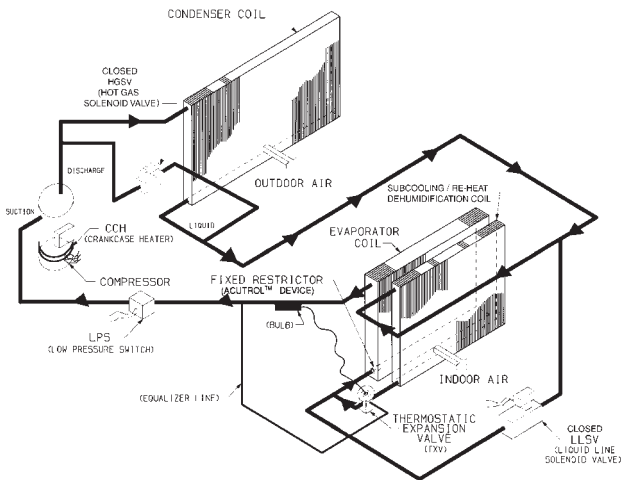
**SERVICE**

**⚠ WARNING**

**ELECTRICAL SHOCK HAZARD**

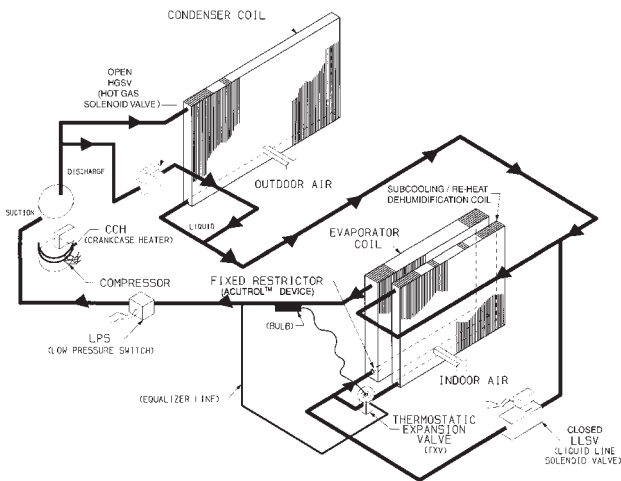
Failure to follow this warning could cause personal injury or death.

When servicing unit, shut off all electrical power to unit and install lockout tag to avoid shock hazard or injury from rotating parts.



**Fig. 54 – Humidi-MiZer Subcooling Mode Operation**

C06136



**Fig. 55 – Humidi-MiZer™ Hot Gas Reheat Mode Operation**

C06137

**Hot Gas Reheat Mode**

When the humidity levels in the space require humidity control, a hot gas solenoid valve (specific to hot gas reheat mode only) will open to bypass a portion of hot gas refrigerant around the condenser coil. (See Fig. 55.)

This hot gas will mix with liquid refrigerant leaving the condenser coil and flow to the subcooling/reheat dehumidification coil. Now the conditioned air coming off the evaporator will be cooled and dehumidified, but will be warmed to neutral conditions (72°F to 75°F) by the subcooling/reheat dehumidification coil.

The net effect of the rooftop when in hot gas reheat mode is to provide nearly all latent capacity removal from the space when sensible loads diminish (when outdoor temperature conditions are moderate). When in hot gas reheat mode, the unit will operate to provide mostly latent capacity and extremely low sensible heat ratio capability.

Similar to the subcooling mode of operation, hot gas reheat mode operates only when the outside air temperature is warmer than 40°F. Below this temperature, a factory installed outside air temperature switch will lockout this mode of operation.

See Table 39 for the Humidi-MiZer adaptive dehumidification system sequence of operation.

**Step 1 —Cleaning**

Inspect unit interior at the beginning of heating and cooling season and as operating conditions require.

**EVAPORATOR COIL**

1. Turn unit power off, tag disconnect. Remove evaporator coil access panel.
2. If economizer or two-position damper is installed, remove economizer by disconnecting Molex plug and removing mounting screws.
3. Slide filters out of unit.
4. Clean coil using a commercial coil cleaner or dishwasher detergent in a pressurized spray canister. Wash both sides of coil and flush with clean water. For best results, back-flush toward return-air section to remove foreign material. Flush condensate pan after completion.
5. Reinstall economizer and filters.
6. Reconnect wiring.
7. Replace access panels.

**Condenser coil**

Inspect coil monthly. Clean condenser coil annually, and as required by location and outdoor air conditions.

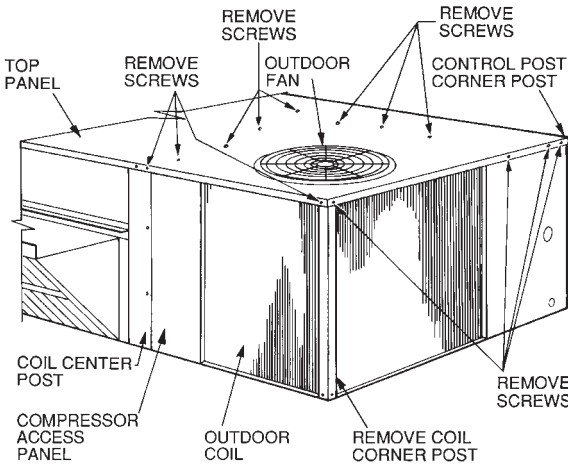
**One-Row Coils**

Wash coil with commercial coil cleaner. It is not necessary to remove top panel.

**2-Row Coils**

Clean coil as follows:

1. Turn off unit power, tag disconnect.
2. Remove top panel screws on condenser end of unit.
3. Remove condenser coil corner post. (See Fig. 56.) To hold top panel open, place coil corner post between top panel and center post. (See Fig. 57.)



**Fig. 56 – Cleaning Condenser Coil**

C06044

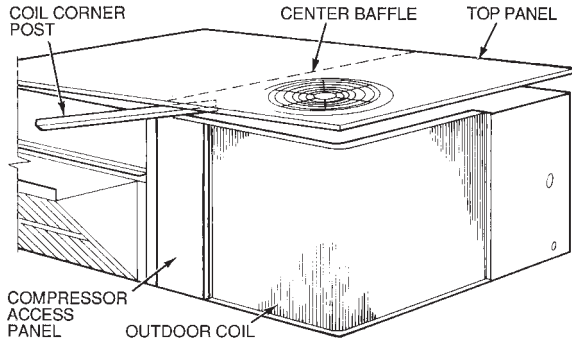
**Table 39—Humidi-Mizer Adaptive Dehumidification System Sequence of Operation and System Response — Single Compressor Unit (48HE003-006, 48HJ004-007)**

THERMOSTAT INPUT			ECONOMIZER FUNCTION		48HE, HJ UNIT OPERATION			
H	Y1	Y2	OAT. < Economizer Set Point	Economizer	Comp. 1	Subcooling Mode	Hot Gas Reheat Mode	
Off	—	—	Normal Operation					
On	On	On	No	Off	On	Yes	No	
On	On	Off	No	Off	On	Yes	No	
On	On	On	Yes	On	On	Yes	No	
On	On	Off	Yes	On	On	No	Yes	
On	Off	Off	No	Off	On	No	Yes	

NOTE: On a thermostat call for W1, all cooling and dehumidification will be off.

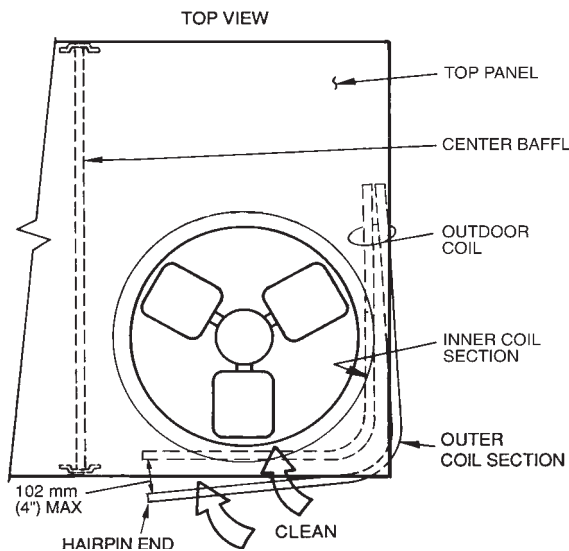
**LEGEND**

OAT – Outdoor Air Temperature



**Fig. 57 – Propping Up Top Panel**

C06045



**Fig. 58 – Separating Coil Sections**

C06046

4. Remove screws securing coil to compressor plate and compressor access panel.
5. Remove fastener holding coil sections together at return end of condenser coil. Carefully separate the outer coil section 3 to 4 in. from the inner coil section. (See Fig. 58.)
6. Use a water hose or other suitable equipment to flush down between the 2 coil sections to remove dirt and debris. Clean the outer surfaces with a stiff brush in the normal manner.
7. Secure inner and outer coil rows together with a field-supplied fastener.
8. Reposition the outer coil section and remove the coil corner post from between the top panel and center post. Reinstall the coil corner post and replace all screws.

**condensate drain**

Check and clean each year at the start of the cooling season. In winter, keep the drain dry or protect it against freeze-up.

**filters**

Clean or replace at the start of each heating and cooling season, or more often if operating conditions require it. Replacement filters must be the same dimensions as the original filters.

**outdoor-air inlet screens**

Clean the screens with steam or hot water and a mild detergent. Do not use disposable filters in place of screens.

**Step 2 —Lubrication**

**compressor**

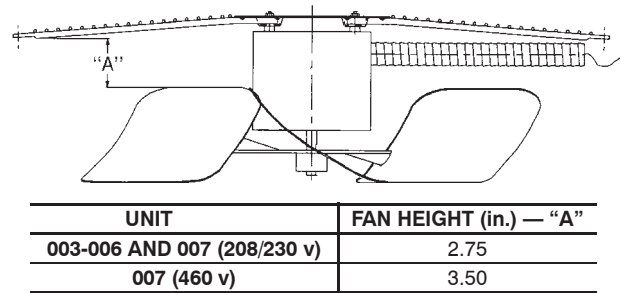
The compressor is charged with the correct amount of oil at the factory.

**fan motor bearings**

Fan motor bearings are permanently lubricated. No further lubrication is required. No lubrication of condenser-fan or evaporator-fan motors is required.

**Step 3 —Condenser-Fan Adjustment**

Shut off unit power supply. Remove condenser-fan assembly (grille, motor, motor cover, and fan) and loosen fan hub setscrews. Adjust fan height as shown in Fig. 59. Tighten setscrews and replace condenser-fan assembly.



**Fig. 59 – Condenser-Fan Adjustment**

C06138

**Step 4 —EconoMiSer IV Adjustment**

Refer to Optional EconoMiSer IV and EconoMiSer2 section.

**Step 5 —Evaporator Fan Belt Inspection**

Check condition of evaporator belt or tension during heating and cooling inspections or as conditions require. Replace belt or adjust as necessary.

**Step 6 —High Pressure Switch**

The high-pressure switch contains a Schrader core depressor, and is located on the compressor hot gas line. This switch opens at 428 psig and closes at 320 psig. No adjustments are necessary.

**48HE, HJ**

**Step 7 —Loss-of-Charge Switch**

The loss-of-charge switch contains a Schrader core depressor, and is located on the compressor liquid line. This switch opens at 7 psig and closes at 22 psig. No adjustments are necessary.

**Step 8 —Freeze-Stat**

The freeze-stat is a bimetal temperature-sensing switch that is located on the “hair-pin” end of the evaporator coil. The switch protects the evaporator coil from freeze-up due to lack of airflow. The switch opens at 30°F and closes at 45°F. No adjustments are necessary.

**Step 9 —Refrigerant Charge**

Amount of refrigerant charge is listed on unit nameplate (also refer to Table 1). Refer to HVAC Servicing Procedures literature available at your local distributor and the following procedures.

Unit panels must be in place when unit is operating during charging procedure. Unit must operate a minimum of 10 minutes before checking or adjusting refrigerant charge.

An accurate superheat, thermocouple-type or thermistor-type thermometer, and a gauge manifold are required when using the superheat charging method for evaluating the unit charge. *Do not use mercury or small dial-type thermometers because they are not adequate for this type of measurement.*

**No charge**

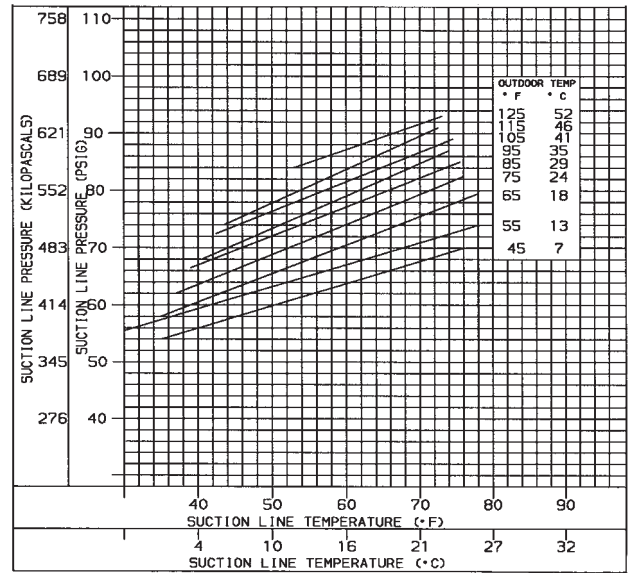
Use standard evacuating techniques. After evacuating system to 500 microns, weigh in the specified amount of refrigerant. (Refer to Table 1 or 2 and unit information plate.)

**Low charge cooling**

Using Cooling Charging Charts, Fig. 60-63, vary refrigerant until the conditions of the charts are met. Note the charging charts are different from type normally used. Charts are based on charging the units to the correct superheat for the various operating conditions. Accurate pressure gage and temperature sensing device are required. Connect the pressure gauge to the service port on the suction line. Mount the temperature sensing device on the suction line and insulate it so that outdoor ambient temperature does not affect the reading. Indoor-air cfm must be within the normal operating range of the unit.

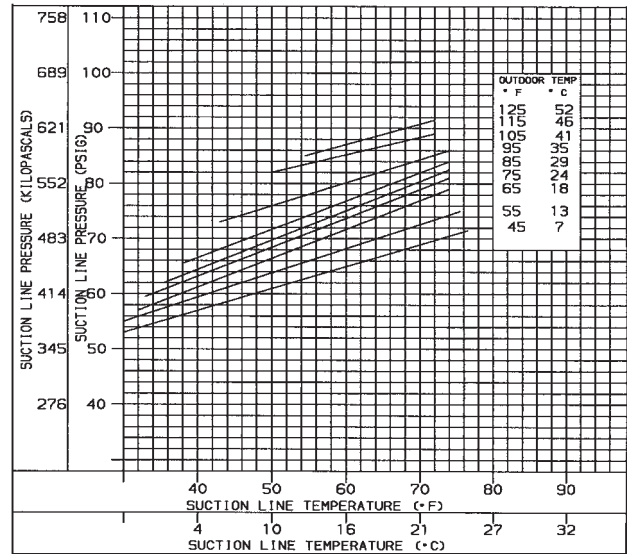
**HUMIDI-MIZER™ SYSTEM CHARGING**

The system charge for units with the Humidi-MiZer adaptive dehumidification system is greater than that of the standard unit alone. The charge for units with this option is indicated on the unit nameplate drawing. Also refer to Fig. 64-67. To charge systems using the Humidi-MiZer adaptive dehumidification system, fully evacuate, recover, and recharge the system to the nameplate specified charge level. To check or adjust refrigerant charge on systems using the Humidi-MiZer adaptive dehumidification system, charge per Fig. 64-67.



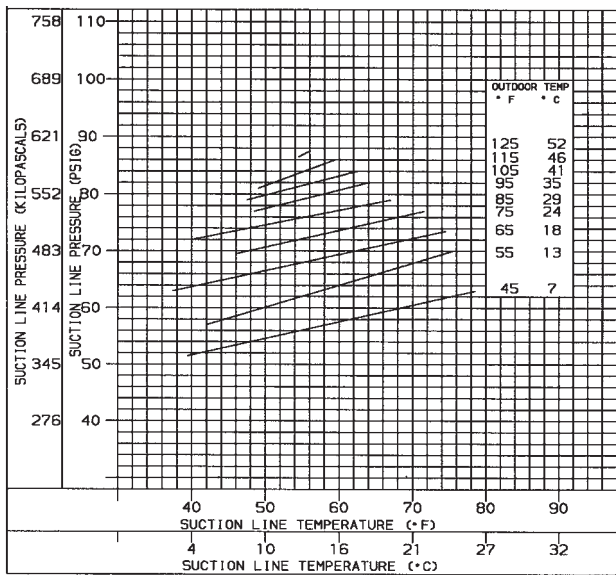
C06139

**Fig. 60 – Cooling Charging Chart, Standard 48HJ004**



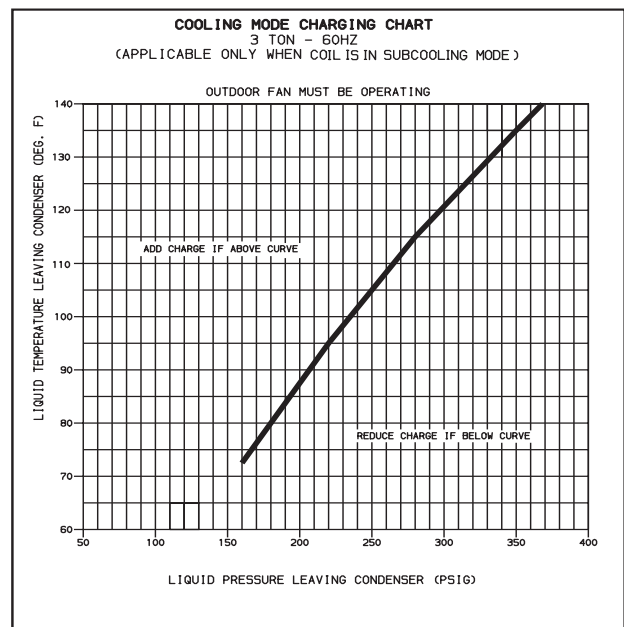
C06140

**Fig. 61 – Cooling Charging Chart, Standard 48HJ005**



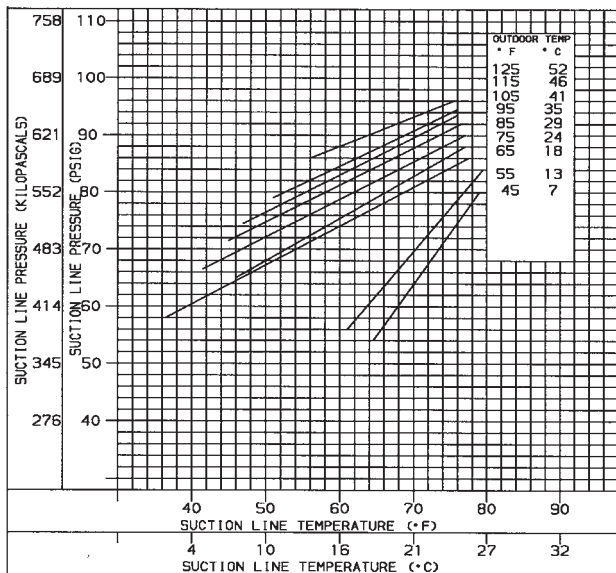
**Fig. 62 – Cooling Charging Chart, Standard 48HJ006**

C06141



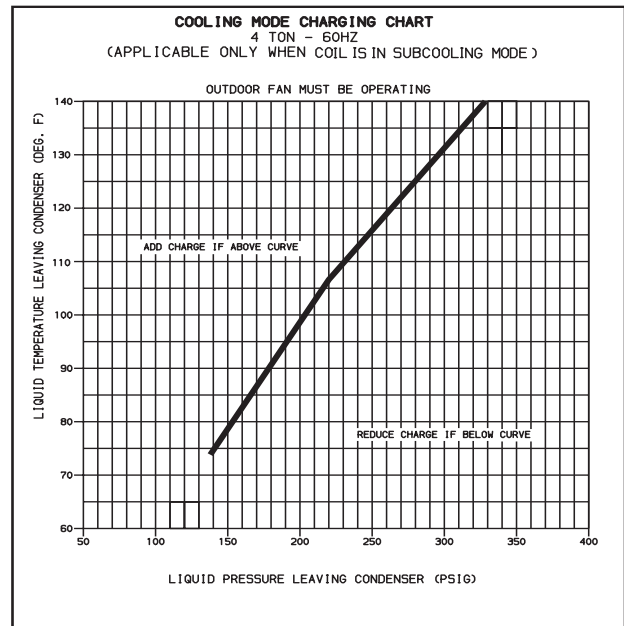
**Fig. 64 – Cooling Charging Chart, 48HJ004 with Optional Humidi-MiZer Adaptive Dehumidification System**

C06143



**Fig. 63 – Cooling Charging Chart, Standard 48HJ007**

C06142



**Fig. 65 – Cooling Charging Chart, 48HJ005 with Optional Humidi-MiZer Adaptive Dehumidification System**

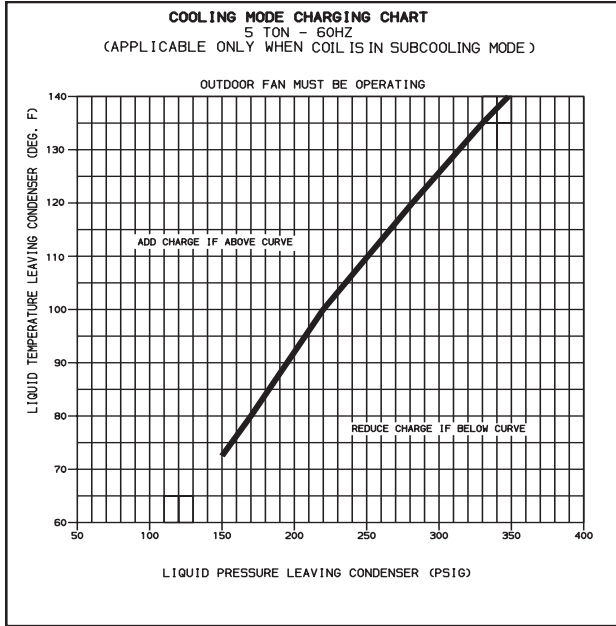
C06144

**NOTE:** When using the charging charts, it is important that only the subcooling/reheat dehumidification coil liquid line solenoid valve be energized. The subcooling/reheat dehumidification coil liquid line solenoid valve **MUST** be energized to use the charging charts and the outdoor motor speed controller jumpered to run the fan at full speed.

**48HE, HJ**

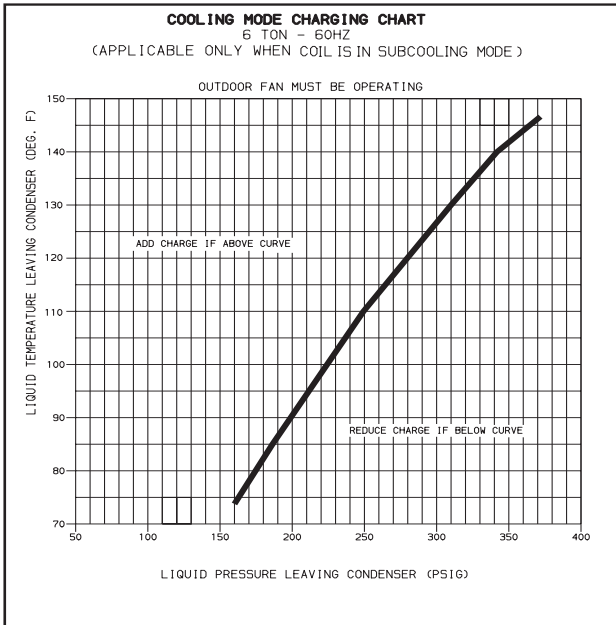
The charts reference a liquid pressure (psig) and temperature at a point between the condenser coil and the subcooling/reheat dehumidification coil. A tap is provided on the unit to measure liquid pressure entering the subcooling/reheat dehumidification coil.

**IMPORTANT:** The subcooling mode charging charts (Fig. 64-67) are to be used **ONLY** with units having the Humidi-MiZer adaptive dehumidification system. **DO NOT** use standard charge (Fig. 60-63) for units with Humidi-MiZer system, and **DO NOT** use Fig. 64-67 for standard units.



**Fig. 66 – Cooling Charging Chart, 48HJ005 with Optional Humidi-MiZer Adaptive Dehumidification System**

C06145



**Fig. 67 – Cooling Charging Chart, 48HJ007 with Optional Humidi-MiZer Adaptive Dehumidification System**

C06146

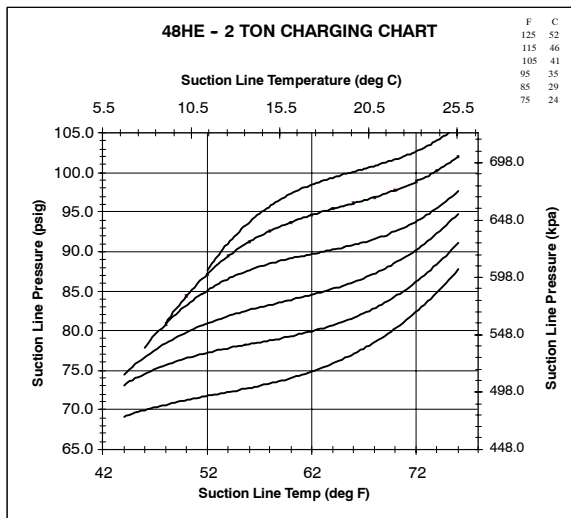
**TO USE COOLING CHARGING CHART, STANDARD UNIT**

Take the outdoor ambient temperature and read the suction pressure gauge. Refer to charts to determine what suction temperature should be. If suction temperature is high, add refrigerant. If suction temperature is low, carefully recover some of the charge. Recheck the suction pressure as charge is adjusted.

Example (Fig. 59):

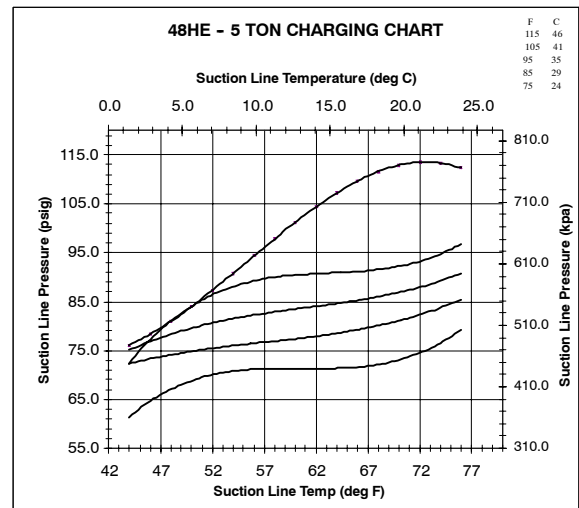
- Outdoor Temperature ..... 75°F
  - Suction Pressure ..... 70 psig
  - Suction Temperature should be ..... 48°F
- (Suction temperature may vary  $\pm 5^\circ\text{F}$ .)

If a charging device is used, temperature and pressure readings must be accomplished using the charging charts.



C06148

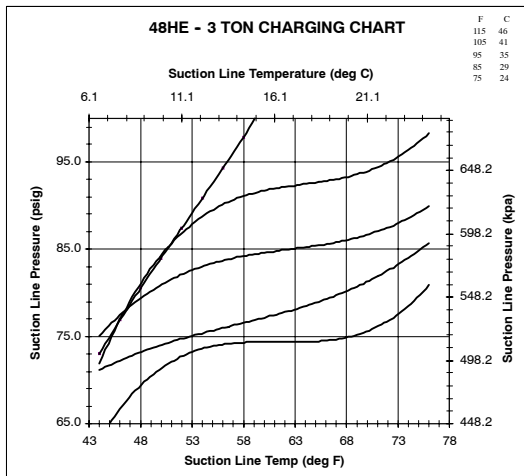
**Fig. 68 – Cooling Charging Chart, Standard 48HE003**



C06151

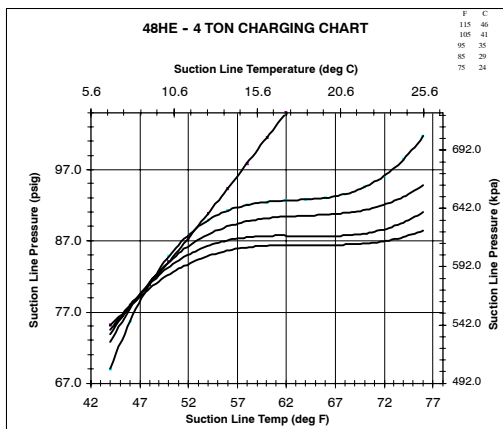
**Fig. 71 – Cooling Charging Chart, Standard 48HE006**

**48HE, HJ**



C06149

**Fig. 69 – Cooling Charging Chart, Standard 48HE004**



C06150

**Fig. 70 – Cooling Charging Chart, Standard 48HE005**

**TO USE COOLING CHARGING CHARTS, UNITS WITH HUMIDI-MIZER™ ADAPTIVE DEHUMIDIFICATION SYSTEM**

Refer to charts (Fig. 64-67) to determine the proper leaving condenser pressure and temperature.

Example (Fig. 64):

Leaving Condenser Pressure . . . . . 250 psig

Leaving Condenser Temperature . . . . . 105°F

**NOTE:** When using the charging charts, it is important that only the subcooling/reheat dehumidification coil liquid line solenoid valve be energized. The subcooling/reheat dehumidification coil liquid line solenoid valve **MUST** be energized to use the charging charts and the outdoor motor speed controller jumpered to run the fan at full speed.

**Step 10 —Flue Gas Passageways**

To inspect the flue collector box and upper areas of the heat exchanger:

1. Remove the combustion blower wheel and motor assembly according to directions in Combustion-Air Blower section below.
2. Remove the 3 screws holding the blower housing to the flue cover.
3. Remove the flue cover to inspect the heat exchanger.
4. Clean all surfaces as required using a wire brush.

**Step 11 —Combustion-Air Blower**

Clean periodically to ensure proper airflow and heating efficiency. Inspect blower wheel every fall and periodically during heating season. For the first heating season, inspect blower wheel bimonthly to determine proper cleaning frequency.

To inspect blower wheel, remove draft hood and screen. Shine a flashlight into opening to inspect wheel. If cleaning is required, remove motor and wheel as follows:

1. Slide burner access panel out.
2. Remove the 5 screws that attach induced-draft motor assembly to the vestibule cover.
3. Slide the motor and blower wheel assembly out of the blower housing. The blower wheel can be cleaned at this point. If additional cleaning is required, continue with Steps 4 and 5.
4. To remove blower from the motor shaft, remove 2 setscrews.
5. To remove motor, remove the 4 screws that hold the motor to mounting plate. Remove the motor cooling fan

by removing one setscrew. Then remove nuts that hold motor to mounting plate.

6. To reinstall, reverse the procedure outlined above.

**Step 12 —Limit Switch**

Remove blower access panel (Fig. 8). Limit switch is located on the fan deck.

**Step 13 —Burner Ignition**

Unit is equipped with a direct spark ignition 100% lockout system. Integrated Gas Unit Controller (IGC) is located in the control box (Fig. 13). A single LED on the IGC provides a visual display of operational or sequential problems when the power supply is uninterrupted. The LED can be observed through the viewport. When a break in power occurs, the IGC will be reset (resulting in a loss of fault history) and the evaporator fan on/off times delay will be reset. During servicing, refer to the label on the control box cover or Table 40 for an explanation of LED error code descriptions.

If lockout occurs, unit may be reset by interrupting power supply to unit for at least 5 seconds.

**Table 40—LED Error Code Description\***

LED INDICATION	ERROR CODE DESCRIPTION
<b>ON</b>	Normal Operation
<b>OFF</b>	Hardware Failure
<b>1 Flash†</b>	Evaporator Fan On/Off Delay Modified
<b>2 Flashes</b>	Limit Switch Fault
<b>3 Flashes</b>	Flame Sense Fault
<b>4 Flashes</b>	4 Consecutive Limit Switch Faults
<b>5 Flashes</b>	Ignition Lockout Fault
<b>6 Flashes</b>	Induced-Draft Motor Fault
<b>7 Flashes</b>	Rollout Switch Fault
<b>8 Flashes</b>	Internal Control Fault
<b>9 Flashes</b>	Software Lockout

**LEGEND**

**LED** — Light-Emitting Diode

\*A 3-second pause exists between LED error code flashes. If more than one error code exists, all applicable codes will be displayed in numerical sequence.

†Indicates a code that is not an error. The unit will continue to operate when this code is displayed.

**IMPORTANT:** Refer to Troubleshooting Tables for additional information.

**Step 14 —Main Burners**

At the beginning of each heating season, inspect for deterioration or blockage due to corrosion or other causes. Observe the main burner flames and adjust, if necessary.



**CAUTION**

**FURNACE DAMAGE HAZARD**

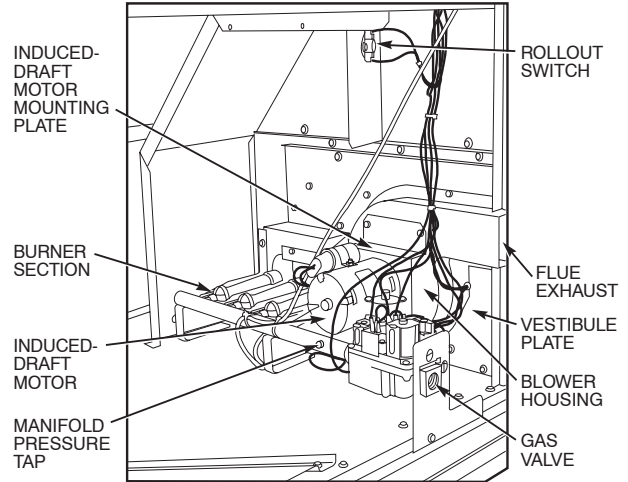
Failure to follow this caution may result in reduced furnace life.

When servicing gas train, do not hit or plug orifice spuds.

**REMOVAL AND REPLACEMENT OF GAS TRAIN**

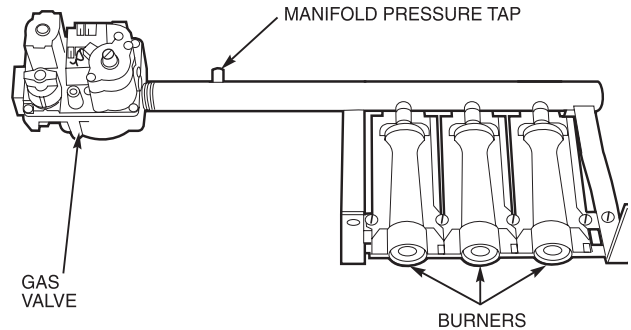
(See Fig. 72 and 73)

1. Shut off manual gas valve.
2. Shut off power to unit, tag disconnect.
3. Remove compressor access panel.
4. Slide out burner compartment side panel.
5. Disconnect gas piping at unit gas valve.
6. Remove wires connected to gas valve. Mark each wire.
7. Remove induced-draft motor, igniter, and sensor wires at the Integrated Gas Unit Controller (IGC).
8. Remove the 2 screws that attach the burner rack to the vestibule plate.
9. Remove the gas valve bracket.
10. Slide the burner tray out of the unit (Fig. 73).
11. To reinstall, reverse the procedure outlined above.



**Fig. 72 – Burner Section Details**

C06152

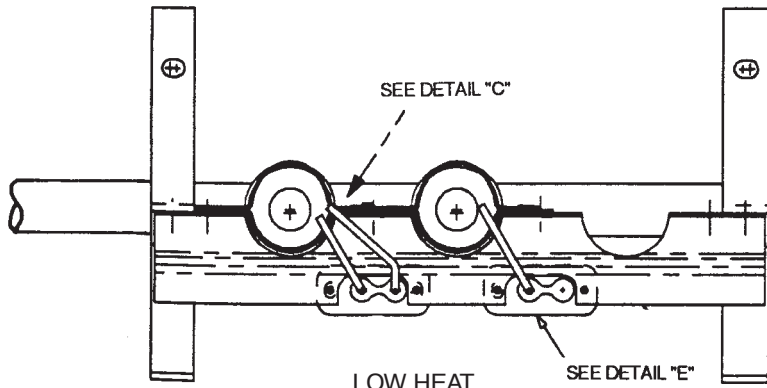


**Fig. 73 – Burner Tray Details**

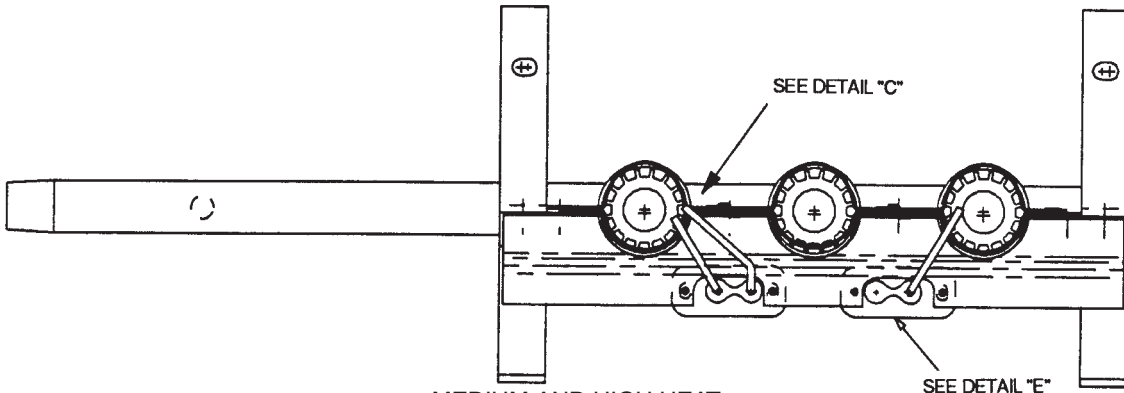
C06153

12. Reinstall burners on rack.



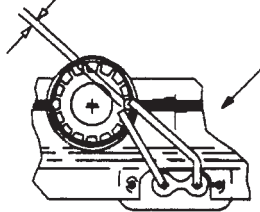


LOW HEAT  
 48HJE/H004, 48HJD/G005-007 — 72,000 BTUH INPUT  
 48HJM004, 48HJL005,006 — 60,000 BTUH INPUT  
 48HEF003, 48HEE004, 48HED005 -



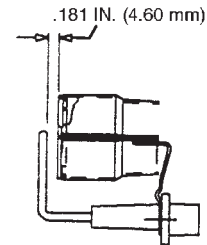
MEDIUM AND HIGH HEAT  
 48HJE/H005-007, 48HJF/K004 — 115,000 BTUH INPUT  
 48HJF/K005-007 — 150,000 BTUH INPUT  
 48HJM005,006; 48HJN004 — 90,000 BTUH INPUT  
 48HJN005,006 — 120,000 BTUH INPUT  
 48HEF004, 48HEE/F005, 48HED/E/F006 -

SPARK GAP  
 .120/.141 IN. (3.05/3.56 mm)



DETAIL "C"

SPARK GAP MUST BE POSITIONED TO IGNITE ON FIRST TRY. (PLACE SPARK GAP WITHIN BURNER CIRCUMFERENCE AS SHOWN)



DETAIL 'E'

**Fig. 74 – Spark Gap Adjustment**

C06154

**Cleaning and Adjustment**

1. Remove burner rack from unit as described above.
2. Inspect burners and, if dirty, remove burners from rack.
3. Using a soft brush, clean burners and cross-over port as required.
4. Adjust spark gap. (See Fig. 74.)

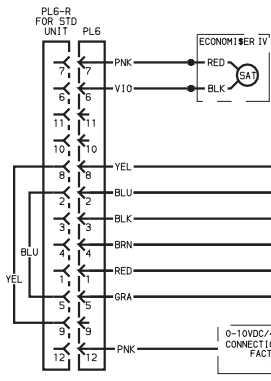
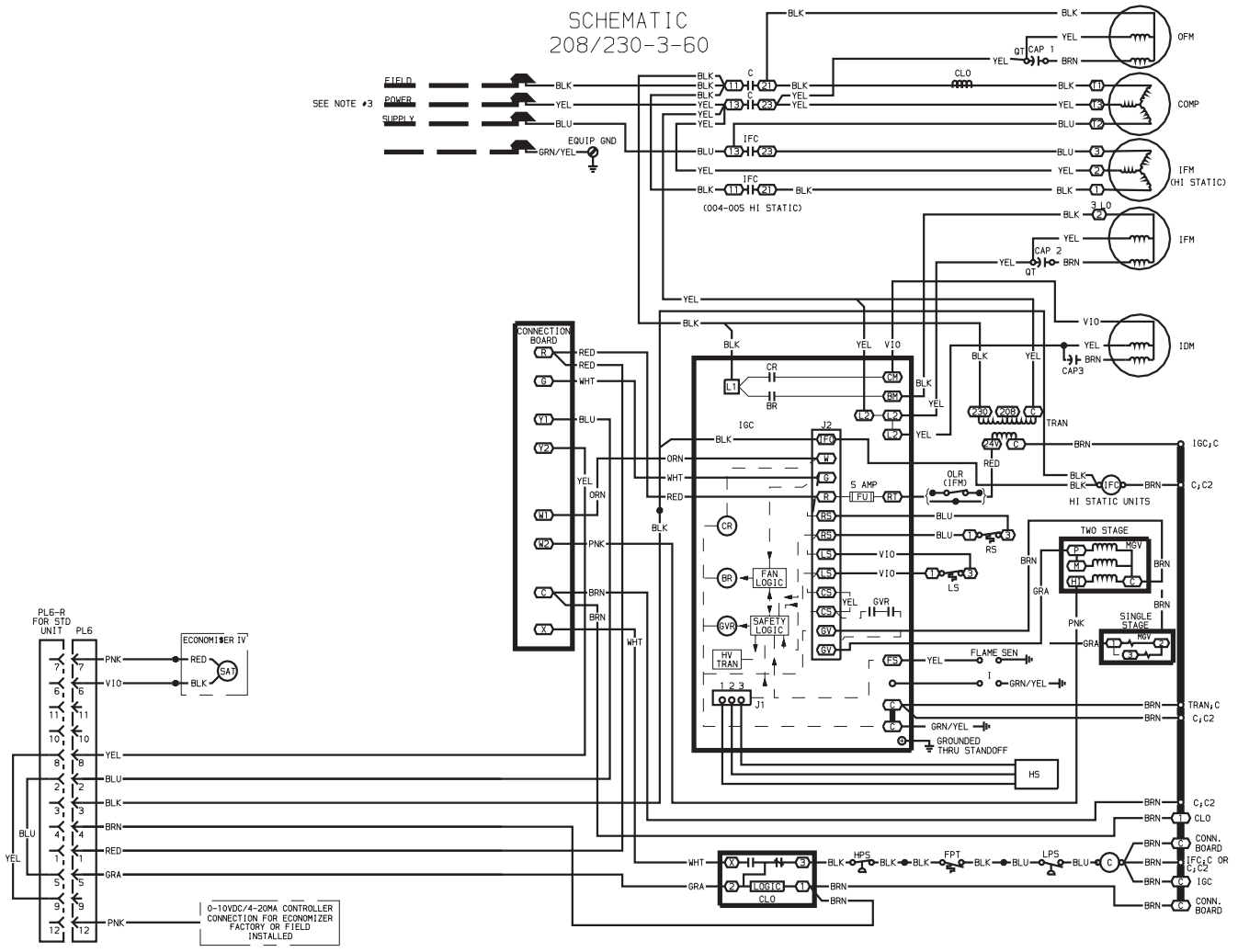
5. Reinstall burner rack as described above.

**Step 15 —Replacement Parts**

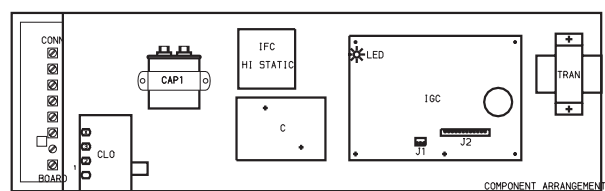
A complete list of replacement parts may be obtained from any Carrier distributor upon request. Refer to Fig. 75 for a typical unit wiring schematic.

48HE, HJ

SCHEMATIC  
208/230-3-60



0-10VDC/4-20MA CONTROLLER CONNECTION FOR ECONOMIZER FACTORY OR FIELD INSTALLED



- NOTES:
1. If any of the original wire furnished must be replaced, it must be replaced with type 90 C wire or its equivalent.
  2. Three phase motors are protected under primary single phasing conditions.
  3. Use copper conductors only.
  4. TRAN is wired for 230 v unit. If unit is to be run with 208 v power supply, disconnect BLK wire from 230 v tap (ORN) and connect to 208 v tap (RED). Insulate end of 230 v tap.

LEGEND

- |  |  |   |
|--|--|---|
| <b>C</b> — Contactor, Compressor             | <b>OFM</b> — Outdoor (Condenser) Fan Motor | Splice  |
| <b>CAP</b> — Capacitor                       | <b>OLR</b> — Overload Relay                | Splice (Marked)   |
| <b>CLO</b> — Compressor Lockout              | <b>P</b> — Plug                            | Factory Wiring  |
| <b>COMP</b> — Compressor Motor               | <b>PL</b> — Plug Assembly                  | Field Control Wiring  |
| <b>EQUIP</b> — Equipment                     | <b>QT</b> — Quadruple Terminal             | Field Power Wiring  |
| <b>FPT</b> — Freeze Up Protection Thermostat | <b>RS</b> — Rollout Switch                 | Accessory or Optional Wiring                                |
| <b>FU</b> — Fuse                             | <b>SAT</b> — Supply Air Temperature Sensor | To indicate common potential only; not to represent wiring. |
| <b>GND</b> — Ground                          | <b>TRAN</b> — Transformer                  |   |
| <b>HPS</b> — High-Pressure Switch            | Field Splice                               |   |
| <b>HS</b> — Hall-Effect Sensor               | Marked Wire                                |   |
| <b>I</b> — Ignitor                           | Terminal (Marked)                          |   |
| <b>IDM</b> — Induced-Draft Motor             | Terminal (Unmarked)                        |   |
| <b>IFC</b> — Indoor Fan Contactor            | Terminal Block                             |   |
| <b>IFM</b> — Indoor Fan Motor                |  |   |
| <b>IGC</b> — Integrated Gas Unit Controller  |  |   |
| <b>LPS</b> — Low-Pressure Switch             |  |   |
| <b>LS</b> — Limit Switch                     |  |   |
| <b>MGV</b> — Main Gas Valve                  |  |   |

Fig. 75 — Typical Wiring Schematic and Component Arrangement (208/230-3-60 Shown)

C06147

# TROUBLESHOOTING

## Step 1 —Unit Troubleshooting

Refer to Tables 35-39 for unit troubleshooting details.

## Step 2 —EconoMi\$er IV Troubleshooting

See Table 40 for EconoMi\$er IV logic.

A functional view of the EconoMi\$er IV is shown in Fig. 69. Typical settings, sensor ranges, and jumper positions are also shown. An EconoMi\$er IV simulator program is available from Carrier to help with EconoMi\$er IV training and troubleshooting.

### EconoMi\$er IV preparation

This procedure is used to prepare the EconoMi\$er IV for troubleshooting. No troubleshooting or testing is done by performing the following procedure.

**NOTE:** This procedure requires a 9-v battery, 1.2 kilo-ohm resistor, and a 5.6 kilo-ohm resistor which are not supplied with the EconoMi\$er IV.

**IMPORTANT:** Be sure to record the positions of all potentiometers before starting troubleshooting.

1. Disconnect power at TR and TR1. All LEDs should be off. Exhaust fan contacts should be open.
2. Disconnect device at P and P1.
3. Jumper P to P1.
4. Disconnect wires at T and T1. Place 5.6 kilo-ohm resistor across T and T1.
5. Jumper TR to 1.
6. Jumper TR to N.
7. If connected, remove sensor from terminals S<sub>O</sub> and +. Connect 1.2 kilo-ohm 4074EJM checkout resistor across terminals S<sub>O</sub> and +.
8. Put 620-ohm resistor across terminals S<sub>R</sub> and +.
9. Set minimum position, DCV set point, and exhaust potentiometers fully CCW (counterclockwise).
10. Set DCV maximum position potentiometer fully CW (clockwise).
11. Set enthalpy potentiometer to D.
12. Apply power (24 vac) to terminals TR and TR1.

### differential enthalpy

To check differential enthalpy:

1. Make sure EconoMi\$er IV preparation procedure has been performed.
2. Place 620-ohm resistor across S<sub>O</sub> and +.
3. Place 1.2 kilo-ohm resistor across S<sub>R</sub> and +. The Free Cool LED should be lit.
4. Remove 620-ohm resistor across S<sub>O</sub> and +. The Free Cool LED should turn off.
5. Return EconoMi\$er IV settings and wiring to normal after completing troubleshooting.

### single enthalpy

To check single enthalpy:

1. Make sure EconoMi\$er IV preparation procedure has been performed.
2. Set the enthalpy potentiometer to A (fully CCW). The Free Cool LED should be lit.
3. Set the enthalpy potentiometer to D (fully CW). The Free Cool LED should turn off.
4. Return EconoMi\$er IV settings and wiring to normal after completing troubleshooting.

### dcv (demand controlled ventilation) and power exhaust

To check DCV and Power Exhaust:

1. Make sure EconoMi\$er IV preparation procedure has been performed.
2. Ensure terminals AQ and AQ1 are open. The LED for both DCV and Exhaust should be off. The actuator should be fully closed.
3. Connect a 9-v battery to AQ (positive node) and AQ1 (negative node). The LED for both DCV and Exhaust should turn on. The actuator should drive to between 90 and 95% open.
4. Turn the Exhaust potentiometer CW until the Exhaust LED turns off. The LED should turn off when the potentiometer is approximately 90%. The actuator should remain in position.
5. Turn the DCV set point potentiometer CW until the DCV LED turns off. The DCV LED should turn off when the potentiometer is approximately 9v. The actuator should drive fully closed.
6. Turn the DCV and Exhaust potentiometers CCW until the Exhaust LED turns on. The exhaust contacts will close 30 to 120 seconds after the Exhaust LED turns on.
7. Return EconoMi\$er IV settings and wiring to normal after completing troubleshooting.

### dcv minimum and maximum position

To check the DCV minimum and maximum position:

1. Make sure EconoMi\$er IV preparation procedure has been performed.
2. Connect a 9-v battery to AQ (positive node) and AQ1 (negative node). The DCV LED should turn on. The actuator should drive to between 90 and 95% open.
3. Turn the DCV Maximum Position potentiometer to midpoint. The actuator should drive to between 20 and 80% open.
4. Turn the DCV Maximum Position potentiometer to fully CCW. The actuator should drive fully closed.
5. Turn the Minimum Position potentiometer to midpoint. The actuator should drive to between 20 and 80% open.
6. Turn the Minimum Position Potentiometer fully CW. The actuator should drive fully open.
7. Remove the jumper from TR and N. The actuator should drive fully closed.
8. Return EconoMi\$er IV settings and wiring to normal after completing troubleshooting.

### supply-air input

To check supply-air input:

1. Make sure EconoMi\$er IV preparation procedure has been performed.
2. Set the Enthalpy potentiometer to A. The Free Cool LED turns on. The actuator should drive to between 20 and 80% open.
3. Remove the 5.6 kilo-ohm resistor and jumper T to T1. The actuator should drive fully open.
4. Remove the jumper across T and T1. The actuator should drive fully closed.
5. Return EconoMi\$er IV settings and wiring to normal after completing troubleshooting.

### econoMi\$er IV troubleshooting completion

This procedure is used to return the EconoMi\$er IV to operation. No troubleshooting or testing is done by performing the following procedure.

1. Disconnect power at TR and TR1.
2. Set enthalpy potentiometer to previous setting.

3. Set DCV maximum position potentiometer to previous setting.
4. Set minimum position, DCV set point, and exhaust potentiometers to previous settings.
5. Remove 620-ohm resistor from terminals S<sub>R</sub> and +.
6. Remove 1.2 kilo-ohm checkout resistor from terminals S<sub>O</sub> and +. If used, reconnect sensor from terminals S<sub>O</sub> and +.

7. Remove jumper from TR to N.
8. Remove jumper from TR to 1.
9. Remove 5.6 kilo-ohm resistor from T and T1. Reconnect wires at T and T1.
10. Remove jumper from P to P1. Reconnect device at P and P1.
11. Apply power (24 vac) to terminals TR and TR1.

**Table 41—LED Error Code Service Analysis**

SYMPTOM	CAUSE	REMEDY
<b>Hardware Failure. (LED OFF)</b>	Loss of power to control module (IGC).	Check 5 amp fuse on IGC, power to unit, 24-v circuit breaker, and transformer. Units without a 24-v circuit breaker have an internal overload in the 24-v transformer. If the overload trips, allow 10 minutes for automatic reset.
<b>Fan ON/OFF Delay Modified (LED/FLASH)</b>	High limit switch opens during heat exchanger warm-up period before fan-on delay expires. Limit switch opens within three minutes after blower-off delay timing in Heating mode.	Ensure unit is fired on rate and temperature rise is correct.  Ensure units' external static pressure is within application guidelines.
<b>Limit Switch Fault. (LED 2 Flashes)</b>	High temperature limit switch is open.	Check the operation of the indoor (evaporator) fan motor. Ensure that the supply-air temperature rise is in accordance with the range on the unit nameplate.
<b>Flame Sense Fault. (LED 3 Flashes)</b>	The IGC sensed flame that should not be present.	Reset unit. If problem persists, replace control board.
<b>4 Consecutive Limit Switch Faults. (LED 4 Flashes)</b>	Inadequate airflow to unit.	Check operation of indoor (evaporator) fan motor and that supply-air temperature rise agrees with range on unit nameplate information.
<b>Ignition Lockout. (LED 5 Flashes)</b>	Unit unsuccessfully attempted ignition for 15 minutes.	Check ignitor and flame sensor electrode spacing, gaps, etc. Ensure that flame sense and ignition wires are properly terminated. Verify that unit is obtaining proper amount of gas.
<b>Induced-Draft Motor Fault. (LED 6 Flashes)</b>	IGC does not sense that induced-draft motor is operating.	Check for proper voltage. If motor is operating, check the speed sensor plug/IGC Terminal J2 connection. Proper connection: PIN 1— White, PIN 2 — Red, PIN 3 — Black.
<b>Rollout Switch Fault. (LED 7 Flashes)</b>	Rollout switch has opened.	Rollout switch will automatically reset, but IGC will continue to lock out unit. Check gas valve operation. Ensure that induced-draft blower wheel is properly secured to motor shaft. Reset unit at unit disconnect.
<b>Internal Control Fault. (LED 8 Flashes)</b>	Microprocessor has sensed an error in the software or hardware.	If error code is not cleared by resetting unit power, replace the IGC.
<b>Temporary Software Lockout (LED 9 Flashes)</b>	Electrical interference is impeding the IGC software.	Reset 24-v to control board or turn thermostat off and then on. Fault will automatically reset itself in one hour.



## CAUTION

### COMPONENT DAMAGE HAZARD

Failure to follow this caution may result in component damage.

If the IGC must be replaced, be sure to ground yourself to dissipate any electrical charge that may be present before handling new control board. The IGC is sensitive to static electricity and may be damaged if the necessary precautions are not taken.

#### LEGEND

**IGC** – Integrated Gas Unit Controller

**LED** – Light–Emitting Diode

**IMPORTANT:** Refer to heating troubleshooting for additional heating section troubleshooting information.

**Table 42— Heating Service Analysis**

<b>PROBLEM</b>	<b>CAUSE</b>	<b>REMEDY</b>
<b>Burners Will Not Ignite.</b>	Misaligned spark electrodes.	Check flame ignition and sensor electrode positioning. Adjust as needed.
	No gas at main burners.	Check gas line for air purge as necessary. After purging gas line of air, allow gas to dissipate for at least 5 minutes before attempting to relight unit. Check gas valve.
	Water in gas line.	Drain water and install drip leg to trap water.
	No power to furnace.	Check power supply, fuses, wiring, and circuit breaker.
	No 24 v power supply to control circuit.	Check transformer. Transformers with internal overcurrent protection require a cool-down period before resetting. Check 24-v circuit breaker; reset if necessary.
	Miswired or loose connections.	Check all wiring and wirenut connections.
	Burned-out heat anticipator in thermostat.	Replace thermostat.
	Broken thermostat wires.	Run continuity check. Replace wires, if necessary.
<b>Inadequate Heating.</b>	Dirty air filter.	Clean or replace filter as necessary.
	Gas input to unit too low.	Check gas pressure at manifold. Clock gas meter for input. If too low, increase manifold pressure or replace with correct orifices.
	Unit undersized for application.	Replace with proper unit or add additional unit.
	Restricted airflow.	Clean filter, replace filter, or remove any restrictions.
	Blower speed too low.	Use high speed tap, increase fan speed, or install optional blower, as suitable for individual units, Adjust pulley.
	Limit switch cycles main burners.	Check rotation of blower, thermostat heat anticipator settings, and temperature rise of unit. Adjust as needed.
	Too much outdoor air.	Adjust minimum position. Check economizer operation.
<b>Poor Flame Characteristics.</b>	Incomplete combustion (lack of combustion air) results in: Aldehyde odors, CO (carbon monoxide), sooting flame, or floating flame.	Check all screws around flue outlets and burner compartment. Tighten as necessary.
		Cracked heat exchanger.
		Overfired unit — reduce input, change orifices, or adjust gas line or manifold pressure.
		Check vent for restriction. Clean as necessary.
<b>Burners Will Not Turn Off.</b>	Unit is locked into Heating mode for a one minute minimum.	Check orifice to burner alignment.
		Wait until mandatory one-minute time period has elapsed or reset power to unit.

**48HE,HJ**

**Table 43—Humidi-MiZer™ Adaptive Dehumidification System Subcooling Mode Service Analysis**

<b>PROBLEM</b>	<b>CAUSE</b>	<b>REMEDY</b>
<b>Subcooling Mode (Liquid Reheat) Will Not Energize.</b>	No power to control transformer from evaporator-fan motor.	Check power source and evaporator-fan relay. Ensure all wire connections are tight.
	No power from control transformer to liquid line solenoid valve.	1. Fuse open; check fuse. Ensure continuity of wiring. 2. Low-pressure switch open. Cycle unit off and allow low-pressure switch to reset. Replace switch if it will not close. 3. Transformer bad; check transformer.
	Liquid line solenoid valve will not operate.	1. Solenoid coil defective; replace. 2. Solenoid valve stuck open; replace.
	Liquid line solenoid valve will not open.	Valve is stuck closed; replace valve.
<b>Low System Capacity.</b>	Low refrigerant charge or frosted evaporator coil.	1. Check charge amount. Charge per Fig. 64-67. 2. Evaporator coil frosted; check and replace low-pressure switch if necessary.
<b>Loss of Compressor Superheat Conditions with Subcooling/Reheat Dehumidification Coil Energized.</b>	Thermostatic expansion valve (TXV).	1. Check TXV bulb mounting, and secure tightly to suction line. 2. Replace TXV if stuck open or closed.

**Table 44—Humidi-MiZer™ Adaptive Dehumidification System Hot Gas Reheat Mode Service Analysis**

<b>PROBLEM</b>	<b>CAUSE</b>	<b>REMEDY</b>
<b>Reheat Mode Will Not Energize.</b>	No power to control transformer from evaporator-fan motor.	Check power source and evaporator-fan relay. Ensure all wire connections are tight.
	No power from control transformer to hot gas line solenoid valve	1. Fuse open; check fuse. Ensure continuity of wiring. 2. Low-pressure switch open. Cycle unit off and allow low-pressure switch to reset. Replace switch if it will not close. 3. Transformer bad; check transformer.
	Hot gas line solenoid valve will not operate.	1. Solenoid coil defective; replace. 2. Solenoid valve stuck closed; replace.
	Low refrigerant charge or frosted evaporator coil.	1. Check charge amount. Charge per Fig. 64–67. 2. Evaporator coil frosted; check and replace low-pressure switch if necessary.
<b>Loss of Compressor Superheat Conditions with Subcooling/Reheat Dehumidification Coil Energized.</b>	Thermostatic expansion valve (TXV).	1. Check TXV bulb mounting, and secure tightly to suction line. 2. Replace TXV if stuck open or closed.
<b>Excessive Superheat.</b>	Liquid line solenoid valve will not operate.	Valve is stuck, replace valve.
	Hot gas line solenoid valve will not close.	Valve is stuck; replace valve.

**Table 45—Cooling Service Analysis**

<b>PROBLEM</b>	<b>CAUSE</b>	<b>REMEDY</b>
<b>Compressor and Condenser Fan Will Not Start.</b>	Power failure.	Call power company.
	Fuse blown or circuit breaker tripped.	Replace fuse or reset circuit breaker.
	Defective thermostat, contactor, transformer, or control relay.	Replace component.
	Insufficient line voltage.	Determine cause and correct.
	Incorrect or faulty wiring.	Check wiring diagram and rewire correctly.
<b>Compressor Will Not Start But Condenser Fan Runs.</b>	Thermostat setting too high.	Lower thermostat setting below room temperature.
	Faulty wiring or loose connections in compressor circuit.	Check wiring and repair or replace.
	Compressor motor burned out, seized, or internal overload open.	Determine cause. Replace compressor.
	Defective run/start capacitor, overload, start relay.	Determine cause and replace.
<b>Compressor Cycles (Other Than Normally Satisfying Thermostat).</b>	One leg of 3-phase power dead.	Replace fuse or reset circuit breaker. Determine cause.
	Refrigerant overcharge or undercharge.	Recover refrigerant, evacuate system, and recharge to nameplate.
	Defective compressor.	Replace and determine cause.
	Insufficient line voltage.	Determine cause and correct.
	Blocked condenser.	Determine cause and correct.
	Defective run/start capacitor, overload, or start relay.	Determine cause and replace.
	Defective thermostat.	Replace thermostat.
	Faulty condenser-fan motor or capacitor.	Replace.
<b>Compressor Operates Continuously.</b>	Restriction in refrigerant system.	Locate restriction and remove.
	Dirty air filter.	Replace filter.
	Unit undersized for load.	Decrease load or increase unit size.
	Thermostat set too low.	Reset thermostat.
	Low refrigerant charge.	Locate leak, repair, and recharge.
	Leaking valves in compressor.	Replace compressor.
	Air in system.	Recover refrigerant, evacuate system, and recharge.
<b>Excessive Head Pressure.</b>	Condenser coil dirty or restricted.	Clean coil or remove restriction.
	Dirty air filter.	Replace filter.
	Dirty condenser coil.	Clean coil.
	Refrigerant overcharged.	Recover excess refrigerant.
	Air in system.	Recover refrigerant, evacuate system, and recharge.
<b>Head Pressure Too Low.</b>	Condenser air restricted or air short-cycling.	Determine cause and correct.
	Low refrigerant charge.	Check for leaks, repair, and recharge.
	Compressor valves leaking.	Replace compressor.
<b>Excessive Suction Pressure.</b>	Restriction in liquid tube.	Remove restriction.
	High heat load.	Check for source and eliminate.
	Compressor valves leaking.	Replace compressor.
<b>Suction Pressure Too Low.</b>	Refrigerant overcharged.	Recover excess refrigerant.
	Dirty air filter.	Replace filter.
	Low refrigerant charge.	Check for leaks, repair, and recharge.
	Metering device or low side restricted.	Remove source of restriction.
	Insufficient evaporator airflow.	Increase air quantity. Check filter and replace if necessary.
	Temperature too low in conditioned area.	Reset thermostat.
<b>Evaporator Fan Will Not Shut Off.</b>	Outdoor ambient below 25 F.	Install low-ambient kit.
	Time off delay not finished.	Wait for 30-second off delay.

48HE, HJ

Table 46—EconoMiSer IV Input/Output Logic

Demand Control Ventilation (DCV)	INPUTS				OUTPUTS			
	Enthalpy*		Y1	Y2	Compressor		N Terminal†	
	Outdoor	Return			Stage 1	Stage 2	Occupied	Unoccupied
Below set (DCV LED Off)	High (Free Cooling LED Off)	Low	On	On	On	On	Minimum position	Closed
			On	Off	On	Off		
			Off	Off	Off	Off		
Above set (DCV LED On)	High (Free Cooling LED Off)	Low	On	On	On	On	Modulating** (between min. position and full-open)	Modulating** (between closed and full-open)
			On	Off	On	Off		
			Off	Off	Off	Off		
Below set (DCV LED Off)	Low (Free Cooling LED On)	High	On	On	On	On	Minimum position	Closed
			On	Off	On	Off		
			Off	Off	Off	Off		
Above set (DCV LED On)	High (Free Cooling LED Off)	Low	On	On	On	On	Modulating†† (between min. position and DCV maximum)	Modulating†† (between closed and DCV maximum)
			On	Off	On	Off		
			Off	Off	Off	Off		
Below set (DCV LED Off)	Low (Free Cooling LED On)	High	On	On	On	On	Modulating***	Modulating†††
			On	Off	On	Off		
			Off	Off	Off	Off		

\*For single enthalpy control, the module compares outdoor enthalpy to the ABCD set point.

†Power at N terminal determines Occupied/Unoccupied setting: 24 vac (Occupied), no power (Unoccupied).

\*\*Modulation is based on the supply-air sensor signal.

††Modulation is based on the DCV signal.

\*\*\*Modulation is based on the greater of DCV and supply-air sensor signals, between minimum position and either maximum position (DCV) or fully open (supply-air signal).

†††Modulation is based on the greater of DCV and supply-air sensor signals, between closed and either maximum position (DCV) or fully open (supply-air signal).

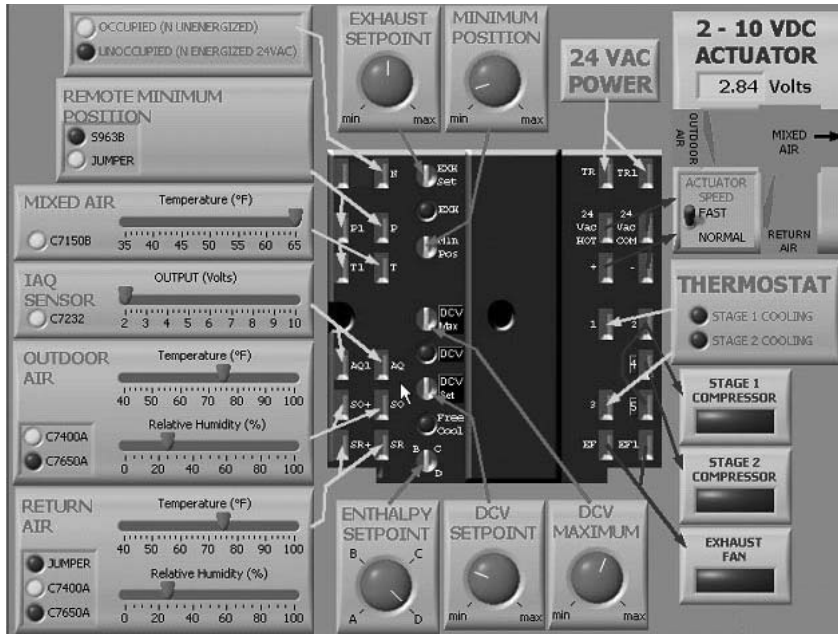


Fig. 76 – EconoMiSer IV Functional View

C06053

48HE, HJ

**START-UP CHECKLIST**  
(Remove and Store in Job File)

**I. PRELIMINARY INFORMATION**

MODEL NO.: \_\_\_\_\_

SERIAL NO.: \_\_\_\_\_

DATE: \_\_\_\_\_

TECHNICIAN: \_\_\_\_\_

**II. PRE-START-UP (insert checkmark in box as each item is completed)**

- VERIFY THAT JOBSITE VOLTAGE AGREES WITH VOLTAGE LISTED ON RATING PLATE
- VERIFY THAT ALL PACKAGING MATERIALS HAVE BEEN REMOVED FROM UNIT
- REMOVE ALL SHIPPING HOLDDOWN BOLTS AND BRACKETS PER INSTALLATION INSTRUCTIONS
- VERIFY THAT CONDENSATE CONNECTION IS INSTALLED PER INSTALLATION INSTRUCTIONS
- CHECK ALL ELECTRICAL CONNECTIONS AND TERMINALS FOR TIGHTNESS
- CHECK GAS PIPING FOR LEAKS
- CHECK THAT RETURN (INDOOR) AIR FILTERS ARE CLEAN AND IN PLACE
- VERIFY THAT UNIT INSTALLATION IS LEVEL
- CHECK FAN WHEELS AND PROPELLER FOR LOCATION IN HOUSING/ORIFICE AND SETSCREW TIGHTNESS
- CHECK TO ENSURE THAT ELECTRICAL WIRING IS NOT IN CONTACT WITH REFRIGERANT LINES OR SHARP METAL EDGES
- CHECK PULLEY ALIGNMENT AND BELT TENSION PER INSTALLATION INSTRUCTIONS

**III. START-UP**

**ELECTRICAL**

SUPPLY VOLTAGE	L1-L2	L2-L3	-	L3-L1	-
COMPRESSOR AMPS	L1	-	L2	-	L3
INDOOR-FAN AMPS	L1	-	L2	-	L3

**TEMPERATURES**

OUTDOOR-AIR TEMPERATURE	-	DB	
RETURN-AIR TEMPERATURE	-	DB	WB
COOLING SUPPLY AIR	-	DB	-
HEATING SUPPLY AIR	-	DB	

**PRESSURES (Cooling Mode)**

GAS INLET PRESSURE	-	IN.WG
GAS MANIFOLD PRESSURE	—	IN.WG (HIGH FIRE)
REFRIGERANT SUCTION	-	PSIG
REFRIGERANT DISCHARGE	-	PSIG

- VERIFY THAT 3-PHASE FAN MOTOR AND BLOWER ARE ROTATING IN CORRECT DIRECTION. IF THEY ARE NOT ROTATING IN CORRECT DIRECTION, LOCKING COLLAR MUST BE RE-TIGHTENED AFTER CORRECTING DIRECTION OF ROTATION
- VERIFY THAT 3-PHASE SCROLL COMPRESSOR IS ROTATING IN THE CORRECT DIRECTION
- VERIFY REFRIGERANT CHARGE USING CHARGING CHARTS

48HE,HJ