

**48KC**

**Single Package Rooftop  
Gas Heating/Electric Cooling Unit  
with Puron® (R-410A) Refrigerant  
Sizes: 04, 05, 06**



# Installation Instructions

**NOTE:** Read the entire instruction manual before starting the installation

## TABLE OF CONTENTS


SAFETY CONSIDERATIONS .....	2	Factory-Option Thru-Base Connections (Electrical Connections) .....	20
Rated Indoor Airflow (cfm) .....	3	Units without Thru-Base Connections .....	21
INSTALLATION .....	8	Field Control Wiring .....	21
Jobsite Survey .....	8	Thermostat .....	21
Step 1 - Plan for Unit Location .....	8	Unit without Thru-Base Connection Kit .....	21
Roof Mount .....	8	Heat Anticipator Settings .....	21
Step 2 - Plan for Sequence of Unit Installation .....	8	Humidi-MiZer® Control Connections .....	22
Curb-Mount Installation .....	8	Humidi-MiZer - Space RH Controller .....	22
Pad-Mount Installation .....	9	EconoMiSer® X (Factory-Installed Option) .....	24
Frame-Mount Installation .....	9	PremierLink™ (Factory Option) .....	25
Step 3 - Inspect Unit .....	9	Supply Air Temperature (SAT) Sensor .....	28
Step 4 - Provide Unit Support .....	9	Outdoor Air Temperature (OAT) Sensor .....	28
Roof Curb Mount .....	9	EconoMiSer2 .....	28
Slab Mount (Horizontal Units Only) .....	9	Field Connections .....	28
Alternate Unit Support (In Lieu of Curb or Slab Mount) .....	9	Space Sensors .....	30
Step 5 - Field Fabricate Ductwork .....	9	Connect Thermostat .....	30
Step 6 - Rig and Place Unit .....	11	Configure the Unit for Thermostat Mode .....	30
Positioning on Curb .....	12	Economizer Controls .....	31
Step 7 - Convert to Horizontal & Connect Ductwork ..	12	Indoor Air Quality (CO <sub>2</sub> sensor) .....	31
Step 8 - Install Outside Air Hood .....	12	Outdoor Air Quality Sensor .....	31
Economizer and Two Position Damper Hood		Space Relative Humidity Sensor or	
Package Removal and Setup — Factory Option ..	12	Humidistat Connections .....	32
Economizer Hood and Two-Position Hood .....	13	Smoke Detector/Fire Shutdown (FSD) .....	32
Step 9 - Units with Hinged Panels Only .....	13	Filter Status Switch .....	33
Step 10 - Install Flue Hood .....	14	Supply Fan Status Switch .....	33
Step 11 - Install Gas Piping .....	14	Remote Occupied Switch .....	33
Factory-Option Thru-Base Connections (Gas Connections) .....	15	Power Exhaust (output) .....	33
Step 12 - Install External Condensate Trap and Line ..	17	CCN Communication Bus .....	33
Step 13 - Make Electrical Connections .....	17	RTU Open Control System .....	35
Field Power Supply .....	17	Supply Air Temperature (SAT) Sensor .....	38
Units with Factory-Installed		Outdoor Air Temperature (OAT) Sensor .....	38
Non-Fused Disconnect .....	18	EconoMiSer2 .....	38
Units without Factory-Installed		Field Connections .....	39
Non-Fused Disconnect .....	19	Space Temperature (SPT) Sensors .....	39
All Units .....	19	Indoor Air Quality (CO <sub>2</sub> ) Sensor .....	39
Convenience Outlets .....	19	Outdoor Air Quality Sensor .....	40
		Space Humidity Sensor or Humidistat .....	40
		Smoke Detector/Fire Shutdown (FSD) .....	41
		Connecting Discrete Inputs .....	41
		Communication Wiring - Protocols .....	42

General ..... 42  
 Local Access ..... 43  
 RTU Open Troubleshooting ..... 43  
 Outdoor Air Enthalpy Control ..... 44  
 Differential Enthalpy Control ..... 44  
 Return Air Enthalpy Sensor ..... 45  
 Smoke Detectors ..... 45  
 Step 14 - Adjust Factory-Installed Options ..... 49  
 Step 15 - Install Accessories ..... 49  
 UNIT START-UP CHECKLIST ..... 51


**SAFETY CONSIDERATIONS**

Improper installation, adjustment, alteration, service, maintenance, or use can cause explosion, fire, electrical shock or other conditions which may cause personal injury or property damage. Consult a qualified installer, service agency, or your distributor or branch for information or assistance. The qualified installer or agency must use factory-authorized kits or accessories when modifying this product. Refer to the individual instructions packaged with the kits or accessories when installing.

Follow all safety codes. Wear safety glasses and work gloves. Use quenching cloths for brazing operations and have a fire extinguisher available. Read these instructions thoroughly and follow all warnings or cautions attached to the unit. Consult local building codes and appropriate national electrical codes (in USA, ANSI/NFPA70, National Electrical Code (NEC); in Canada, CSA C22.1) for special requirements.

It is important to recognize safety information. This is the safety-alert symbol . When you see this symbol on the unit and in instructions or manuals, be alert to the potential for personal injury.


Understand the signal words DANGER, WARNING, CAUTION, and NOTE. These words are used with the safety-alert symbol. DANGER identifies the most serious hazards which **will** result in severe personal injury or death. WARNING signifies hazards which **could** result in personal injury or death. CAUTION is used to identify unsafe practices, which **may** result in minor personal injury or product and property damage. NOTE is used to highlight suggestions which **will** result in enhanced installation, reliability, or operation.

** WARNING**

**FIRE, EXPLOSION HAZARD**

Failure to follow this warning could result in personal injury or death.

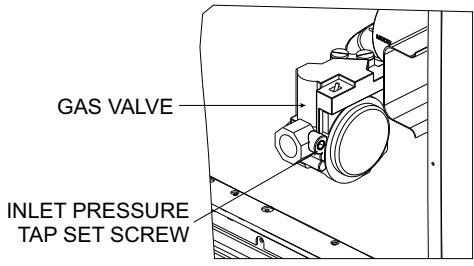
Disconnect gas piping from unit when leak testing at pressure greater than 0.5 psig (3450 Pa). Pressures greater than 0.5 psig (3450 Pa) will cause gas valve damage resulting in hazardous condition. If gas valve is subjected to pressure greater than 0.5 psig (3450 Pa), it must be replaced before use. When pressure testing field-supplied gas piping at pressures of 0.5 psig (3450 Pa) or less, a unit connected to such piping must be isolated by closing the manual gas valve.

** WARNING**

**FIRE HAZARD**


Failure to follow this warning could result in personal injury, death, and/or property damage.

Inlet pressure tab set screw must be tightened and 1/8 in. NPT pipe plug must be installed to prevent gas leaks.



GAS VALVE

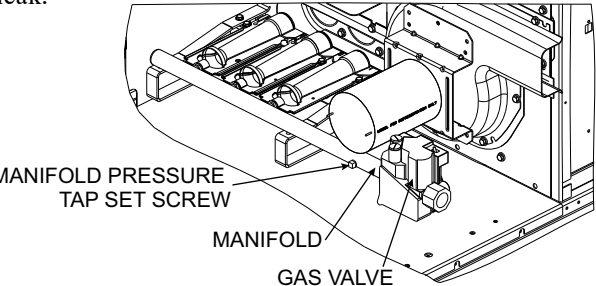
INLET PRESSURE TAP SET SCREW

** WARNING**

**FIRE HAZARD**

Failure to follow this warning could result in personal injury, death, and/or property damage.


Manifold pressure tap set screw must be tightened and 1/8 in. NPT pipe plug must be installed to prevent gas leak.



MANIFOLD PRESSURE TAP SET SCREW

MANIFOLD

GAS VALVE


** WARNING**

**CARBON-MONOXIDE POISONING HAZARD**

Failure to follow instructions could result in severe personal injury or death due to carbon-monoxide poisoning, if combustion products infiltrate into the building.

Check that all openings in the outside wall around the vent (and air intake) pipe(s) are sealed to prevent infiltration of combustion products into the building.

Check that furnace vent (and air intake) terminal(s) are not obstructed in any way during all seasons.

** WARNING**

**ELECTRICAL SHOCK HAZARD**

Failure to follow this warning could cause personal injury or death.

Before performing service or maintenance operations on unit, always turn off main power switch to unit and install lock(s) and lockout tag(s). Unit may have more than one power switch.

## **⚠ WARNING**

### **UNIT OPERATION AND SAFETY HAZARD**

Failure to follow this warning could cause personal injury, death and/or equipment damage.

Puron® (R-410A) refrigerant systems operate at higher pressures than standard R-22 systems. Do not use R-22 service equipment or components on Puron refrigerant equipment.

## **⚠ WARNING**

### **PERSONAL INJURY AND ENVIRONMENTAL HAZARD**

Failure to follow this warning could cause personal injury or death.

Relieve pressure and recover all refrigerant before system repair or final unit disposal.

Wear safety glasses and gloves when handling refrigerants. Keep torches and other ignition sources away from refrigerants and oils.

## **⚠ CAUTION**

### **CUT HAZARD**

Failure to follow this caution may result in personal injury.

Sheet metal parts may have sharp edges or burrs. Use care and wear appropriate protective clothing, safety glasses and gloves when handling parts and servicing air conditioning equipment.

### **Rated Indoor Airflow (cfm)**

The following table lists the rated indoor airflow used for the AHRI efficiency rating for the units covered in this document.

<b>Model Number</b>	<b>Full Load Airflow (cfm)</b>
48KC*A/B04	1050
48KC*A/B05	1400
48KC*A/B06	1750

48KC

Position:	1	2	3	4	5	6	7	8	9	10	11	12	13	14	15	16	17	18
Example:	4	8	K	C	D	A	0	4	A	0	A	5	-	0	A	0	A	0

**48KC**

**Unit Heat Type**  
48 - Gas Heat Packaged Rooftop

**Model Series - WeatherMaker®**  
KC - Standard 14 SEER Efficiency

**Heat Options**  
 D = Low Gas Heat  
 E = Medium Gas Heat  
 F = High Gas Heat  
 L = Low Nox — Low Gas Heat  
 M = Low Nox — Medium Gas Heat  
 N = Low Nox — High Gas Heat  
 S = Low Heat w/ Stainless Steel Exchanger  
 R = Medium Heat w/ Stainless Steel Exchanger  
 T = High Heat w/ Stainless Steel Exchanger  
 (Low Nox models include — Stainless Steel HX)

**Refrig. Systems Options**  
 A = Standard One Stage Cooling Models  
 B = Standard One Stage Cooling Models with Humidi-MiZer®

**Cooling Tons**  
 04 - 3 ton  
 05 - 4 ton  
 06 - 5 ton

**Sensor Options**  
 A = None  
 B = RA Smoke Detector  
 C = SA Smoke Detector  
 D = RA + SA Smoke Detector  
 E = CO<sub>2</sub>  
 F = RA Smoke Detector and CO<sub>2</sub>  
 G = SA Smoke Detector and CO<sub>2</sub>  
 H = RA + SA Smoke Detector and CO<sub>2</sub>

**Indoor Fan Options**  
 0 = Direct Drive ECM  
 2 = Medium Static Option  
 3 = High Static Option

**Coil Options - Round Tube/Plate Fin Condenser Coil (Outdoor - Indoor - Hail Guard)**  
 A = Al/Cu - Al/Cu  
 B = Precoat Al/Cu - Al/Cu  
 C = E-coat Al/Cu - Al/Cu  
 D = E-coat Al/Cu - E-coat Al/Cu  
 E = Cu/Cu - Al/Cu  
 F = Cu/Cu - Cu/Cu  
 M = Al/Cu -Al/Cu — Louvered Hail Guard  
 N = Precoat Al/Cu - Al/Cu — Louvered Hail Guard  
 P = E-coat Al/Cu - Al/Cu — Louvered Hail Guard  
 Q = E-coat Al/Cu - E-coat Al/Cu — Louvered Hail Guard  
 R = Cu/Cu - Al/Cu — Louvered Hail Guard  
 S = Cu/Cu - Cu/Cu — Louvered Hail Guard

**Factory Assigned**  
 0 = Standard  
 1 = LTL

**Electrical Options**  
 A = None  
 C = Non-Fused Disconnect  
 D = Thru-The-Base Connections  
 F = Non-Fused Disconnect and Thru-The-Base Connections

**Service Options**  
 0 = None  
 1 = Unpowered Convenience Outlet  
 2 = Powered Convenience Outlet  
 3 = Hinged Access Panels  
 4 = Hinged Access Panels and Unpowered Convenience Outlet  
 5 = Hinged Panels and Powered Convenience Outlet

**Intake / Exhaust Options**  
 A = None  
 B = Temperature Economizer w/ Barometric Relief  
 F = Enthalpy Economizer w/ Barometric Relief  
 K = 2-Position Damper  
 U = Temperature Ultra Low Leak Economizer w/ Barometric Relief  
 W = Enthalpy Ultra Low Leak Economizer w/ Barometric Relief

**Base Unit Controls**  
 0 = Electro-mechanical Controls can be used with W7212 EconoMi\$er IV (Non-Fault Detection and Diagnostic)  
 1 = PremierLink Controller  
 2 = RTU Open Multi-Protocol Controller  
 6 = Electro-mechanical with W7220 Economizer controller Controls. Can be used with W7220 EconoMi\$er X (with Fault Detection and Diagnostic)

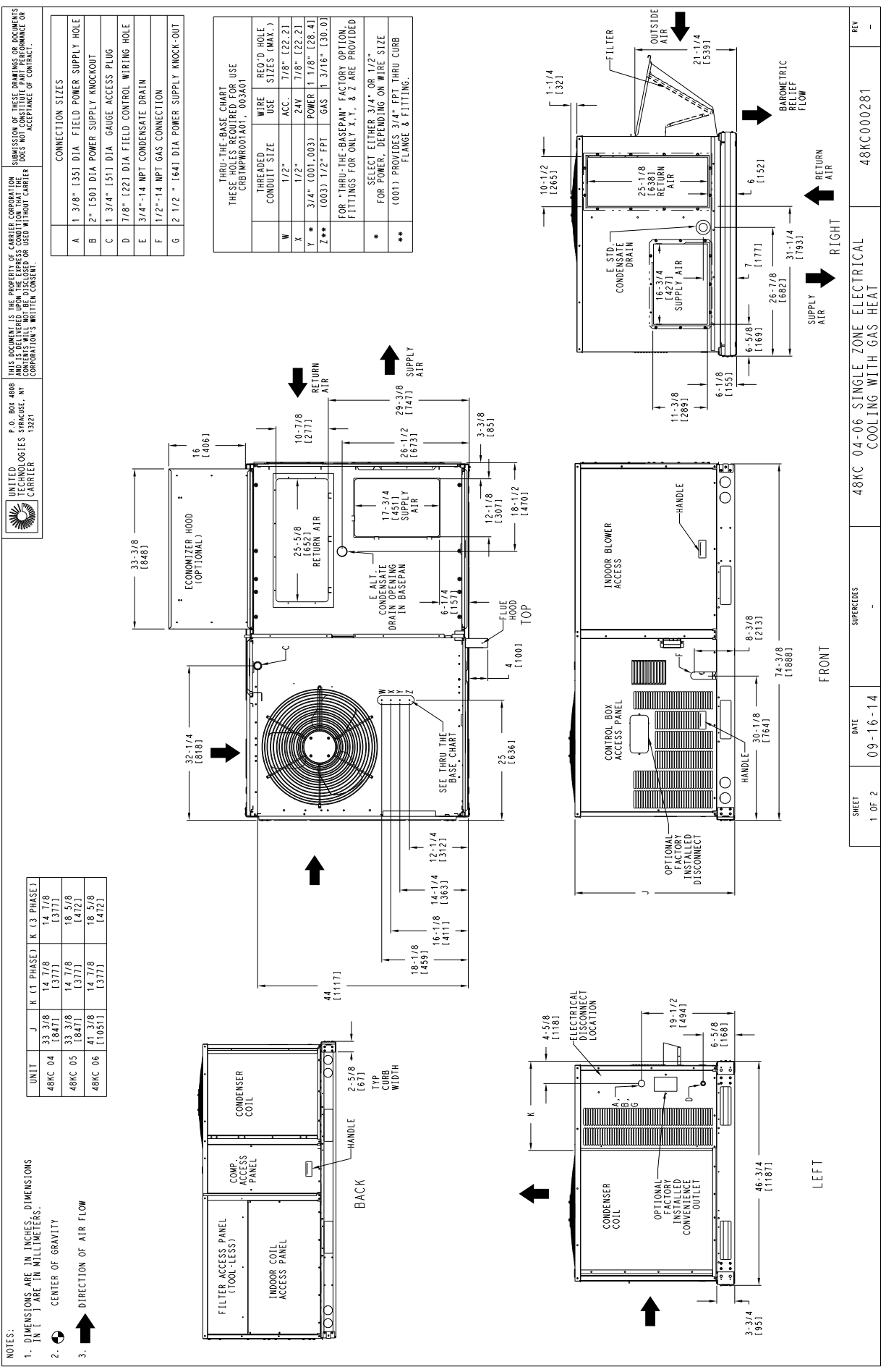
**Design Revision**  
 - = Factory Design Revision

**Voltage**  
 1 = 575/3/60  
 3 = 208-230/1/60  
 5 = 208-230/3/60  
 6 = 460/3/60

**Note: On single phase (-3 voltage code) models, the following are not available as a factory installed option:**  
 - Humidi-MiZer  
 - Coated Coils or Cu Fin Coils  
 - Louvered Hail Guards  
 - Economizer or 2 Position Damper  
 - Powered 115 Volt Convenience Outlet

**Fig. 1 - 48KC 04-06 Model Number Nomenclature (Example)**

C14312



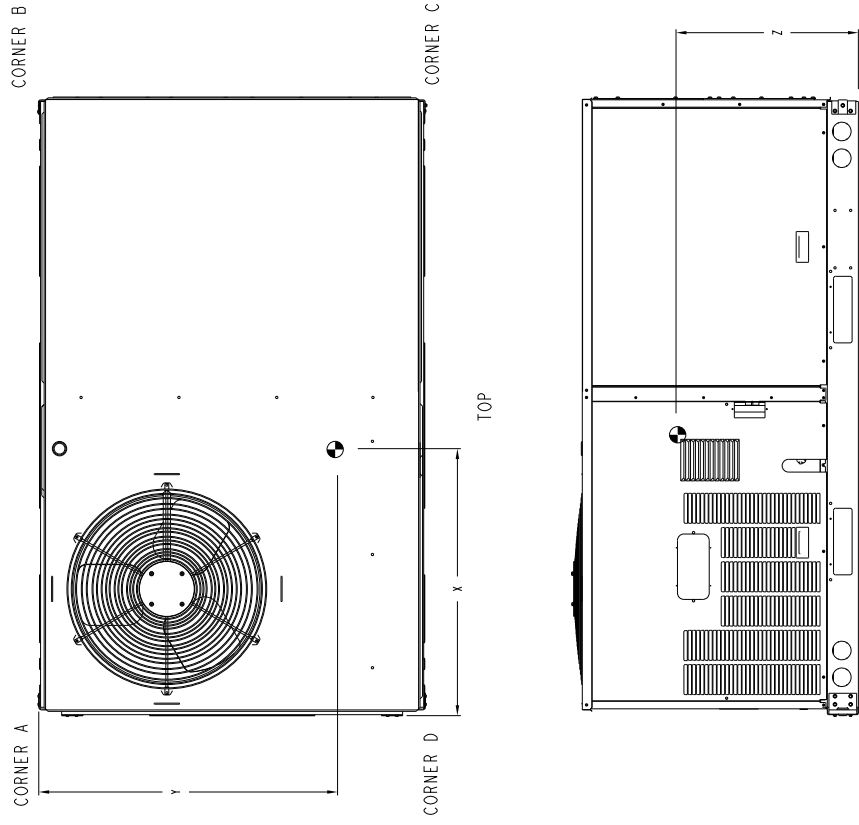
**Fig. 2 - Unit Dimensional Drawing**



UNITED TECHNOLOGIES STRACOSUE, NY CORPORATION'S WRITTEN CONSENT.  
 P. O. BOX 4808  
 THIS DOCUMENT IS THE PROPERTY OF CARRIER CORPORATION AND IS DELIVERED UPON THE EXPRESS CONDITION THAT THE USER SHALL NOT REPRODUCE OR USE IT FOR ANY PURPOSES WITHOUT CARRIER'S WRITTEN CONSENT.  
 THIS DOCUMENT IS THE PROPERTY OF CARRIER CORPORATION AND IS DELIVERED UPON THE EXPRESS CONDITION THAT THE USER SHALL NOT REPRODUCE OR USE IT FOR ANY PURPOSES WITHOUT CARRIER'S WRITTEN CONSENT.

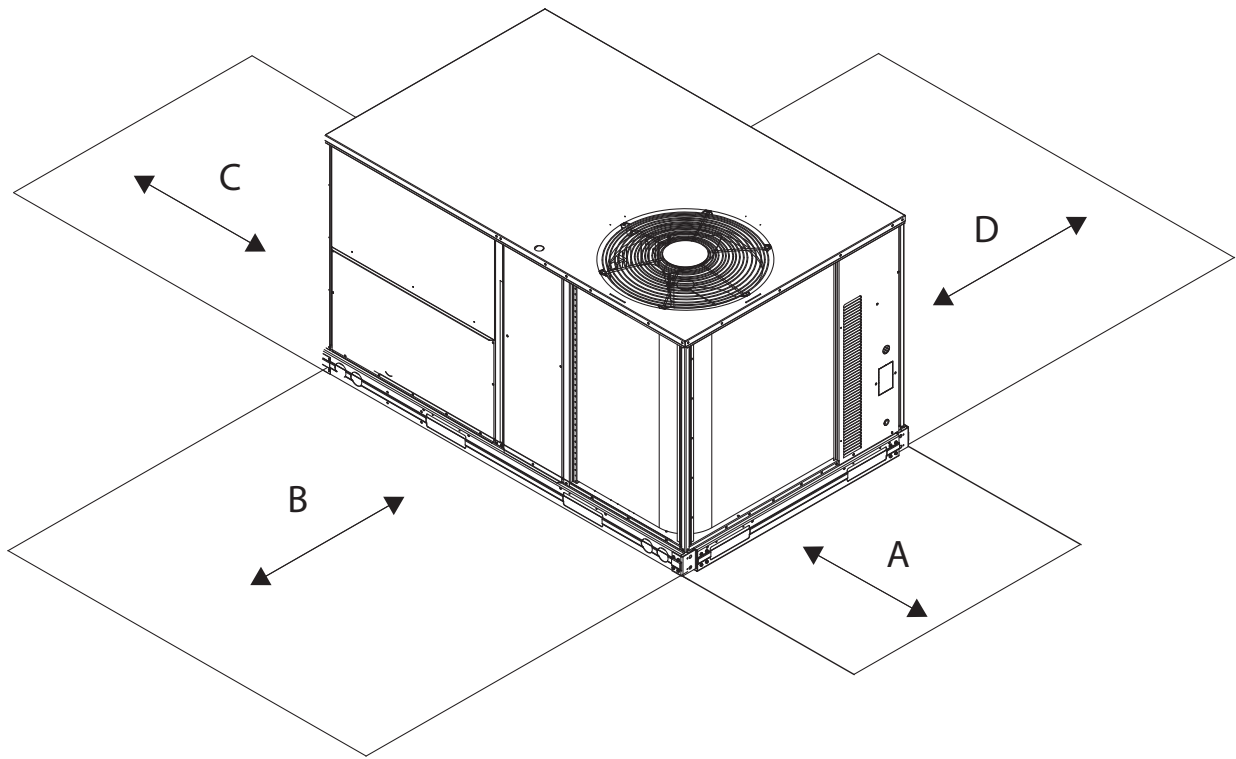
UNIT	STD. UNIT WEIGHT		CORNER WEIGHT (A)		CORNER WEIGHT (B)		CORNER WEIGHT (C)		CORNER WEIGHT (D)		C. G.		HEIGHT						
	LBS.	KG.	LBS.	KG.	LBS.	KG.	LBS.	KG.	LBS.	KG.	X	Y	Z	Z					
48KC 04	490	222	120	54	111	50	125	56	135	61	35	3/4	[908]	24	3/4	[628]	18	7/8	[479]
48KC 05	544	246	130	58	126	57	142	64	146	66	36	3/4	[933]	24	3/4	[628]	18	7/8	[479]
48KC 06	597	270	141	64	156	70	158	71	142	64	39	1/8	[993]	23	1/2	[597]	20	1/8	[511]

\* STANDARD UNIT WEIGHT IS WITH LOW GAS HEAT AND WITHOUT PACKAGING.  
 FOR OTHER OPTIONS AND ACCESSORIES, REFER TO THE PRODUCT DATA CATALOG.



SHEET 2 OF 2	DATE 09-16-14	SUPERCEDES -	48KC 04-06 SINGLE ZONE ELECTRICAL COOLING WITH GAS HEAT	REV -
-----------------	------------------	-----------------	---	----------

**Fig. 2 - Unit Dimensional Drawing (cont.)**



48KC

C08337

LOCATION	DIMENSION	CONDITION
A	48-in (1219 mm) 18-in (457 mm) 18-in (457 mm) 12-in (305 mm)	Unit disconnect is mounted on panel No disconnect, convenience outlet option Recommended service clearance Minimum clearance
B	42-in (1067 mm) 36-in (914 mm) Special	Surface behind servicer is grounded (e.g., metal, masonry wall) Surface behind servicer is electrically non-conductive (e.g., wood, fiberglass) Check sources of flue products within 10-ft of unit fresh air intake hood
C	36-in (914 mm) 18-in (457 mm)	Side condensate drain is used Minimum clearance
D	48-in (1219 mm) 42-in (1067 mm) 36-in (914 mm) Special	No flue discharge accessory installed, surface is combustible material Surface behind servicer is grounded (e.g., metal, masonry wall, another unit) Surface behind servicer is electrically non-conductive (e.g., wood, fiberglass) Check for adjacent units or building fresh air intakes within 10-ft (3 m) of this unit's flue outlet

**NOTE:** Unit not designed to have overhead obstruction. Contact Application Engineering for guidance on any application planning overhead obstruction or for vertical clearances.

**Fig. 3 - Service Clearance Dimensional Drawing**

# INSTALLATION

## Jobsite Survey

Complete the following checks before installation.

1. Consult local building codes and the NEC (National Electrical Code) ANSI/NFPA 70 for special installation requirements.
2. Determine unit location (from project plans) or select unit location.
3. Check for possible overhead obstructions which may interfere with unit lifting or rigging.

### Step 1 — Plan for Unit Location

Select a location for the unit and its support system (curb or other) that provides for the minimum clearances required for safety. This includes the clearance to combustible surfaces, unit performance and service access below, around and above unit as specified in unit drawings. See Fig. 3.

**NOTE:** Consider also the effect of adjacent units.

Be sure that unit is installed such that snow will not block the combustion intake or flue outlet.

Unit may be installed directly on wood flooring or on Class A, B, or C roof-covering material when roof curb is used.

Do not install unit in an indoor location. Do not locate air inlets near exhaust vents or other sources of contaminated air. For proper unit operation, adequate combustion and ventilation air must be provided in accordance with Section 5.3 (Air for Combustion and Ventilation) of the National Fuel Gas Code, ANSI Z223.1 (American National Standards Institute) and NFPA (National Fire Protection Association) 54 TIA--54--84--1. In Canada, installation must be in accordance with the CAN1--B149 installation codes for gas burning appliances.

Although unit is weatherproof, avoid locations that permit water from higher level runoff and overhangs to fall onto the unit.

Locate mechanical draft system flue assembly at least 4 ft (1.2 m) from any opening through which combustion

products could enter the building, and at least 4 ft (1.2 m) from any adjacent building (or per local code). Locate the flue assembly at least 10 ft (3.05 m) from an adjacent unit's fresh air intake hood if within 3 ft (0.91 m) of same elevation (or per local code). When unit is located adjacent to public walkways, flue assembly must be at least 7 ft (2.1 m) above grade.

Select a unit mounting system that provides adequate height to allow installation of condensate trap per requirements. Refer to Step 12 — Install External Condensate Trap and Line – for required trap dimensions.

### Roof Mount —

Check building codes for weight distribution requirements. Unit operating weight is shown in Table 1.

### Step 2 — Plan for Sequence of Unit Installation

The support method used for this unit will dictate different sequences for the steps of unit installation. For example, on curb-mounted units, some accessories must be installed on the unit before the unit is placed on the curb. Review the following for recommended sequences for installation steps.

### Curb-mounted Installation —

- Install curb
- Install field-fabricated ductwork inside curb
- Install accessory thru-base service connection package (affects curb and unit) (refer to accessory installation instructions for details)
- Prepare bottom condensate drain connection to suit planned condensate line routing (refer to Step 12 for details)
- Rig and place unit
- Install outdoor air hood
- Install flue hood
- Install gas piping
- Install condensate line trap and piping
- Make electrical connections
- Install other accessories

**Table 1 – Operating Weights**

48KC**	UNITS LB (KG)	UNITS LB (KG)	UNITS LB (KG)
	04	05	06
Base Unit	490 (222)	544 (246)	597 (270)
Economizer			
Vertical	50 (23)	50 (23)	50 (23)
Horizontal	80 (36)	80 (36)	80 (36)
Humidi-MiZer® System	50 (23)	50 (23)	50 (23)
Cu Fins	25 (11)	43 (20)	56 (25)
Powered Outlet	35 (16)	35 (16)	35 (16)
Curb			
14-in/356 mm	115 (52)	115 (52)	115 (52)
24-in/610 mm	197 (89)	197 (89)	197 (89)



**Pad-mounted Installation —**

- Prepare pad and unit supports
- Check and tighten the bottom condensate drain connection plug
- Rig and place unit
- Convert unit to side duct connection arrangement
- Install field-fabricated ductwork at unit duct openings
- Install outdoor air hood
- Install flue hood
- Install gas piping
- Install condensate line trap and piping
- Make electrical connections
- Install other accessories

**Frame-mounted Installation —**

Frame-mounted applications generally follow the sequence for a curb installation. Adapt as required to suit specific installation plan.

**Step 3 — Inspect Unit**

Inspect unit for transportation damage. File any claim with transportation agency.  
 Confirm before installation of unit that voltage, amperage and circuit protection requirements listed on unit data plate agree with power supply provided.

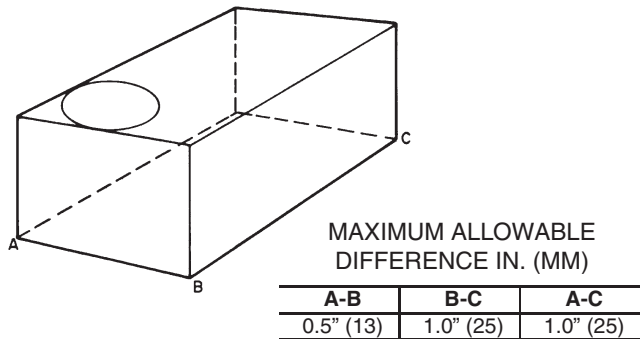
**Step 4 — Provide Unit Support**

**Roof Curb Mount —**

Accessory roof curb details and dimensions are shown in Fig. 5 (on page 10). Assemble and install accessory roof curb in accordance with instructions shipped with the curb.

**NOTE:** The gasketing of the unit to the roof curb is critical for a watertight seal. Install gasket supplied with the roof curb as shown in Fig. 5. Improperly applied gasket can also result in air leaks and poor unit performance.

Curb should be level. This is necessary for unit drain to function properly. Unit leveling tolerances are shown in Fig. 4. Refer to Accessory Roof Curb Installation Instructions for additional information as required.



**Fig. 4 - Unit Leveling Tolerances**

C06110

Install insulation, cant strips, roofing felt, and counter flashing as shown. *Ductwork must be attached to curb and*

*not to the unit. The accessory thru-the-base power and gas connection package must be installed before the unit is set on the roof curb.* If field-installed thru-the-roof curb gas connections are desired, use factory-supplied 1/2-in. pipe coupling and gas plate assembly to mount the thru-the-roof curb connection to the roof curb. Gas connections and power connections to the unit must be field installed after the unit is installed on the roof curb.

If electric and control wiring is to be routed through the basepan, attach the accessory thru-the-base service connections to the basepan in accordance with the accessory installation instructions.

**Slab Mount (Horizontal Units Only) —**

Provide a level concrete slab that extends a minimum of 6 in. (150 mm) beyond unit cabinet. Install a gravel apron in front of condenser coil air inlet to prevent grass and foliage from obstructing airflow.

**NOTE:** Horizontal units may be installed on a roof curb if required.

**Alternate Unit Support (In Lieu of Curb or Slab Mount) —**

A non-combustible sleeper rail can be used in the unit curb support area. If sleeper rails cannot be used, support the long sides of the unit with a minimum of 3 equally spaced 4-in. x 4-in. (102 mm x 102 mm) pads on each side.

**Step 5 — Field Fabricate Ductwork**

Cabinet return-air static pressure (a negative condition) shall not exceed 0.35 in. wg (87 Pa) with economizer or 0.45 in. wg (112 Pa) without economizer.

For vertical ducted applications, secure all ducts to roof curb and building structure. *Do not connect ductwork to unit.*

Fabricate supply ductwork so that the cross sectional dimensions are equal to or greater than the unit supply duct opening dimensions for the first 18 in. (458 mm) of duct length from the unit basepan.

Insulate and weatherproof all external ductwork, joints, and roof openings with counter flashing and mastic in accordance with applicable codes.

Ducts passing through unconditioned spaces must be insulated and covered with a vapor barrier.

If a plenum return is used on a vertical unit, the return should be ducted through the roof deck to comply with applicable fire codes.

A minimum clearance is not required around ductwork.

**▲ CAUTION**

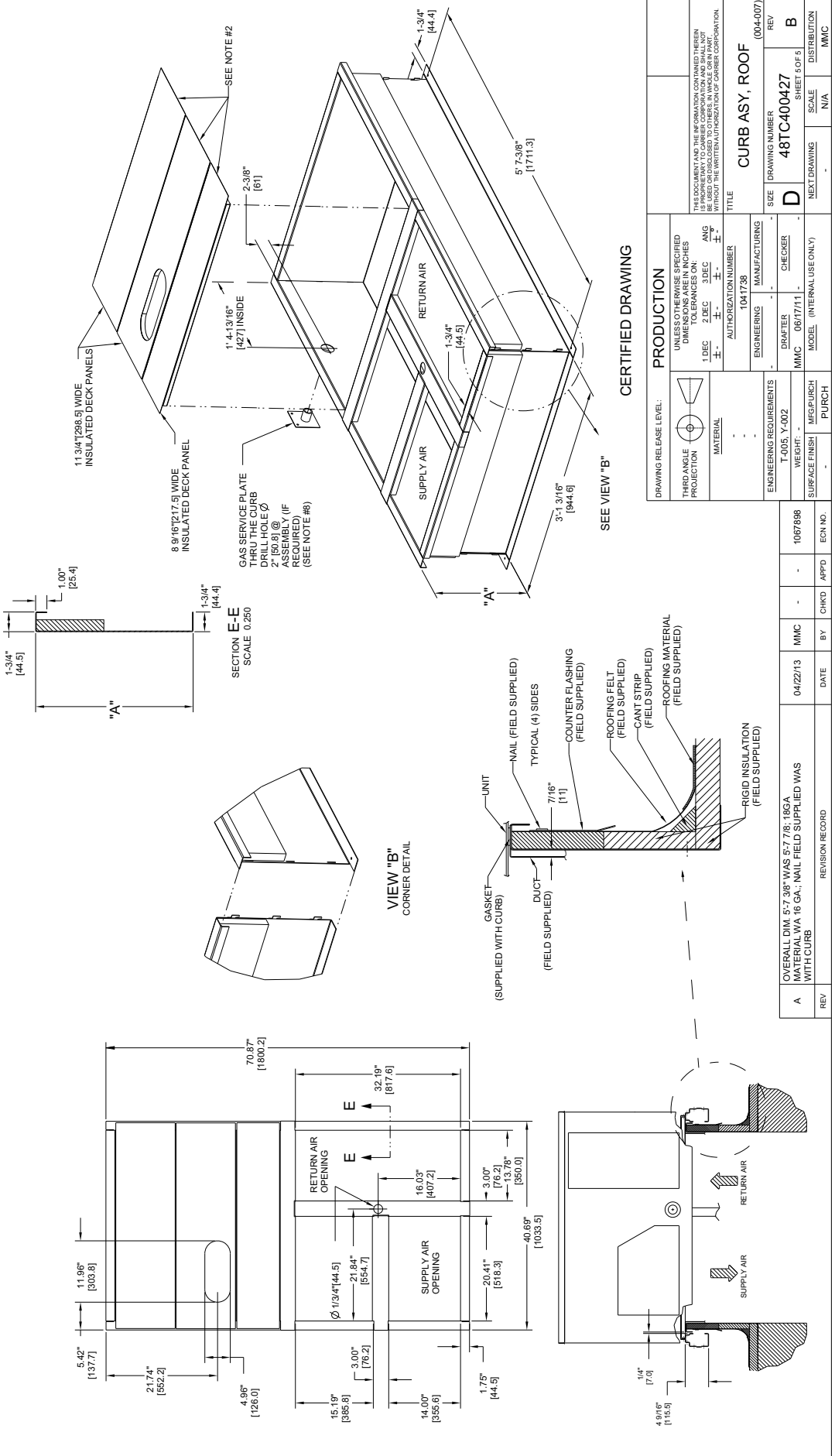
**PROPERTY DAMAGE HAZARD**

Failure to follow this caution may result in damage to roofing materials.

Membrane roofs can be cut by sharp sheet metal edges. Be careful when placing any sheet metal parts on such roof.

ROOF CURB ACCESSORY #	A	CONNECTOR PKG. ACC.	GAS CONNECTION TYPE	GAS FITTING	POWER WIRING FITTING	CONTROL WIRING FITTING	ACCESSORY CONVENIENCE OUTLET WIRING CONNECTOR
CRRFURB001A01	14" [356]	CRBTMPWR001A01	THRU THE CURB	3/4" [19] NPT	3/4" [19] NPT	1/2" [12.7] NPT	1/2" [12.7] NPT
CRRFURB002A01	24" [610]	CRBTMPWR003A01	THRU THE BOTTOM	1/2" [12.7] NPT	1/2" [12.7] NPT		

- NOTES:
1. ROOF CURB ACCESSORY IS SHIPPED DISASSEMBLED.
  2. INSULATED PANELS: 25.4 [1"] THK POLYURETHANE FOAM, 44.5 [1.34"] # DENSITY.
  3. DIMENSIONS IN PARENTHESIS ARE IN MILLIMETERS.
  4. DIMENSIONS IN BRACKETS ARE IN INCHES.
  5. ATTACH DUCTWORK TO CURB. IF FLANGES OF DUCT REST ON CURB.
  6. SERVICE CLEARANCE 4 FEET ON EACH SIDE.
  7. DIRECTION OF AIR FLOW.
  8. CONNECTOR PACKAGE CRBTMPWR001A01 IS FOR THRU-THE-CURB GAS TYPE PACKAGE CRBTMPWR003A01 IS FOR THRU-THE-BOTTOM TYPE GAS CONNECTIONS.



DRAWING RELEASE LEVEL:		PRODUCTION	
THIRD ANGLE PROJECTION	UNLESS OTHERWISE SPECIFIED DIMENSIONS ARE IN INCHES	1. DEC 2011	2. DEC 2011
MATERIAL	ANG	±	±
ENGINEERING REQUIREMENTS	MANUFACTURING	1041738	
T-005, Y-002	CHECKER		
WEIGHT	DRFTR	MMC	06/17/11
SURFACE FINISH	MGFPURCH	MODEL	(INTERNAL USE ONLY)
	PURCH		
TITLE		SIZE	DRAWING NUMBER
CURB ASY., ROOF		D	481C400427
		SCALE	DISTRIBUTION
		N/A	MMC

REV	DATE	BY	CHKD	APPD	ECONO
A	04/22/13	MMC			1067698

REV	DATE	BY	CHKD	APPD	ECONO

Fig. 5 - Roof Curb Details

### Step 6 — Rig and Place Unit

Keep unit upright and do not drop. Spreader bars are required. Rollers may be used to move unit across a roof. Level by using unit frame as a reference. See Table 1 and Fig. 6 for additional information.

Lifting holes are provided in base rails as shown in Fig. 6. Refer to rigging instructions on unit.

Rigging materials under unit (cardboard to prevent base pan damage) must be removed PRIOR to placing the unit on the roof curb.

When using the standard side drain connection, ensure the red plug in the alternate bottom connection is tight. Do this before setting the unit in place. The red drain pan plug can be tightened with a 1/2-in. square socket drive extension. For

further details see “Step 12 - Install External Condensate Trap and Line” on page 17.

## ⚠ CAUTION

### UNIT DAMAGE HAZARD

Failure to follow this caution may result in equipment damage.

All panels must be in place when rigging. Unit is not designed for handling by fork truck.

Before setting the unit onto the curb, recheck gasketing on curb.

## ⚠ CAUTION - NOTICE TO RIGGERS: ⚠ AVERTISSEMENT - REMARQUE À L'ATTENTION DES MONTEURS

ALL PANELS MUST BE IN PLACE WHEN RIGGING.  
TOUS LES CAPOTS DOIVENT ÊTRE EN PLACE AVANT LE LEVAGE

- Hook rigging shackles through holes in base rail, as shown in detail “A”.
- Use wooden top skid, when rigging, to prevent rigging straps from damaging unit.
- Spreader bars required to lift and transport the unit.
- Accrocher les manilles des élingues de levages dans les trous situés dans le rail de base comme indiqué au détail « A ».
- Utiliser des cales en bois lors du levage pour éviter que les élingues n'endommagent le haut de l'appareil.
- Barres d'écartement requises pour soulever et transporter l'unité.

PLACE ALL SEAL STRIP IN PLACE BEFORE PLACING UNIT ON ROOF CURB.  
INSTALLER TOUTES LES BANDES D'ISOLATION EN PLACE AVANT DE PLACER L'APPAREIL SUR LE REBORD DE TOIT.

### DETAIL A DÉTAIL « A »

	MAX WEIGHT		A		B		C	
	LB	KG	IN	MM	IN	MM	IN	MM
<b>48KC04</b>	795	361	74.5	1890	39.0	990	33.5	850
<b>48KC05</b>	890	405	74.5	1890	39.0	990	33.5	850
<b>48KC06</b>	1020	464	74.5	1890	39.0	990	41.5	1055
<b>50KC04</b>	760	345	74.5	1890	38.0	965	33.5	850
<b>50KC05</b>	850	386	74.5	1890	38.0	965	33.5	850
<b>50KC06</b>	985	448	74.5	1890	38.0	965	41.5	1055
<b>50KCQ04</b>	755	343	74.5	1890	38.5	980	33.5	850
<b>50KCQ05</b>	870	395	74.5	1890	37.5	955	41.5	1055
<b>50KCQ06</b>	925	420	74.5	1890	37.5	955	41.5	1055

48KC000261 -

48KC

Fig. 6 - Rigging Label

**Positioning on Curb —**

Position unit on roof curb so that the following clearances are maintained: 1/4 in. (6.4 mm) clearance between the roof curb and the base rail inside the front and rear, 0.0 in. clearance between the roof curb and the base rail inside on the duct end of the unit. This will result in the distance between the roof curb and the base rail inside on the condenser end of the unit being approximately 1/4 in. (6.4 mm).

Although unit is weatherproof, guard against water from higher level runoff and overhangs.

*Flue vent discharge must have a minimum horizontal clearance of 4 ft (1220 mm) from electric and gas meters, gas regulators, and gas relief equipment. Minimum distance between unit and other electrically live parts is 48 inches (1220 mm).*

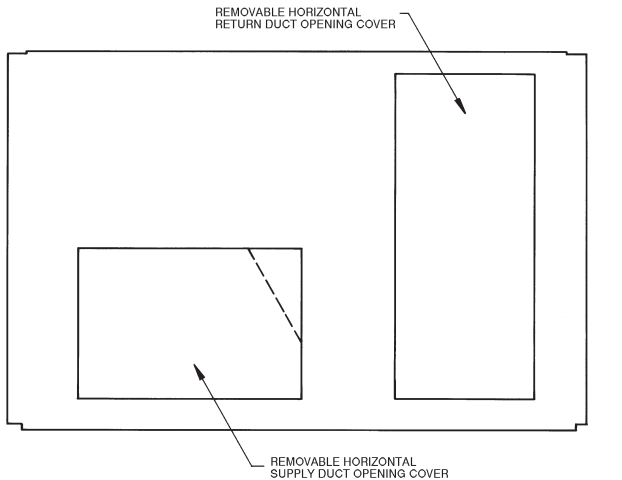
Flue gas can deteriorate building materials. Orient unit such that flue gas will not affect building materials. Locate mechanical draft system flue assembly at least 48 in. (1220 mm) from an adjacent building or combustible material.

**NOTE:** Installation of accessory flue discharge deflector kit will reduce the minimum clearance to combustible material to 18 in. (460 mm).

After unit is in position, remove rigging skids and shipping materials.

**Step 7 — Convert to Horizontal and Connect Ductwork (when required)**

Unit is shipped in the vertical duct configuration. Unit *without* factory-installed economizer or return air smoke detector option may be field-converted to horizontal ducted configuration. To convert to horizontal configuration, remove screws from side duct opening covers and remove covers. Using the same screws, install covers on vertical duct openings with the insulation-side down. Seals around duct openings must be tight. See Fig. 7.



**Fig. 7 - Horizontal Conversion Panels**

Field-supplied flanges should be attached to horizontal duct openings and all ductwork should be secured to the flanges. Insulate and weatherproof all external ductwork, joints, and roof or building openings with counter flashing and mastic in accordance with applicable codes.

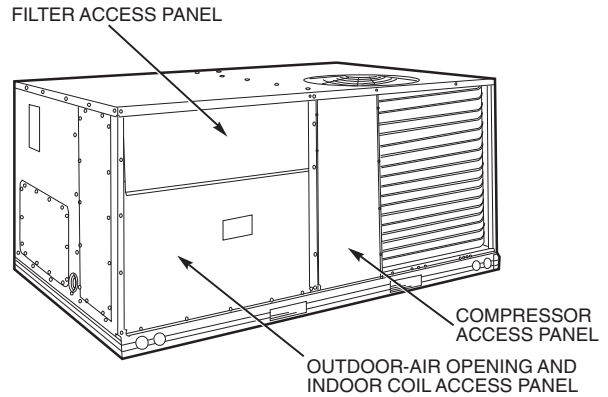
Do not cover or obscure visibility to the unit's informative data plate when insulating horizontal ductwork.

**Step 8 — Install Outside Air Hood**

**Economizer and Two Position Damper Hood Package Removal and Setup - Factory Option**

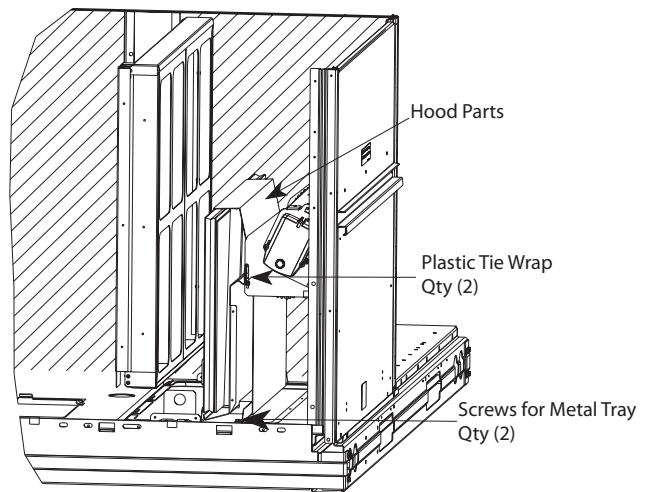
**NOTE:** Economizer and two position damper are not available as factory installed options for single phase (-3 voltage code) models.

1. The hood is shipped in knock-down form and must be field assembled. The indoor coil access panel is used as the hood top while the hood sides, divider and filter are packaged together, attached to a metal support tray using plastic stretch wrap, and shipped in the return air compartment behind the indoor coil access panel. The hood assembly's metal tray is attached to the basepan and also attached to the damper using two plastic tie-wraps.
2. To gain access to the hood, remove the filter access panel. (See Fig. 8.)



**Fig. 8 - Typical Access Panel Locations**

3. Locate the (2) screws holding the metal tray to the basepan and remove. Locate and cut the (2) plastic tie-wraps securing the assembly to the damper. (See Fig. 9) Be careful to not damage any wiring or cut tie-wraps securing any wiring.



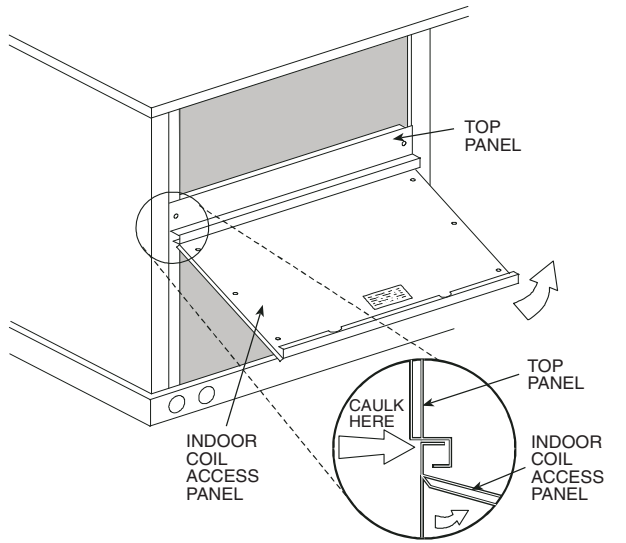
**Fig. 9 - Economizer and Two-Position Damper Hood Parts Location**

- Carefully lift the hood assembly (with metal tray) through the filter access opening and assemble per the steps outlined in *Economizer Hood and Two-Position Hood*, below.

**Economizer Hood and Two-Position Hood —**

**NOTE:** If the power exhaust accessory is to be installed on the unit, the hood shipped with the unit will not be used and must be discarded. Save the aluminum filter for use in the power exhaust hood assembly.

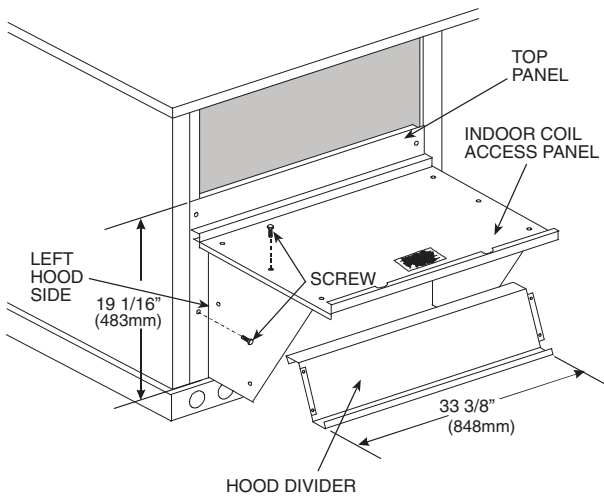
- The indoor coil access panel will be used as the top of the hood. Remove the screws along the sides and bottom of the indoor coil access panel. See Fig. 10.



**Fig. 10 - Indoor Coil Access Panel Relocation**

C06025

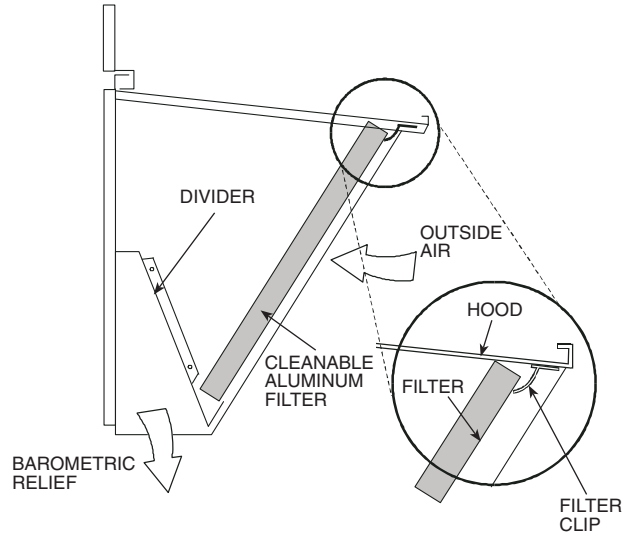
- Swing out indoor coil access panel and insert the hood sides under the panel (hood top). Use the screws provided to attach the hood sides to the hood top. Use screws provided to attach the hood sides to the unit. See Fig. 11.



**Fig. 11 - Economizer Hood Construction**

C06026

- Remove the shipping tape holding the economizer barometric relief damper in place (economizer only).
- Insert the hood divider between the hood sides. See Fig. 11 and 12. Secure hood divider with 2 screws on each hood side. The hood divider is also used as the bottom filter rack for the aluminum filter.
- Open the filter clips which are located underneath the hood top. Insert the aluminum filter into the bottom filter rack (hood divider). Push the filter into position past the open filter clips. Close the filter clips to lock the filter into place. See Fig. 12.
- Caulk the ends of the joint between the unit top panel and the hood top.
- Replace the filter access panel.



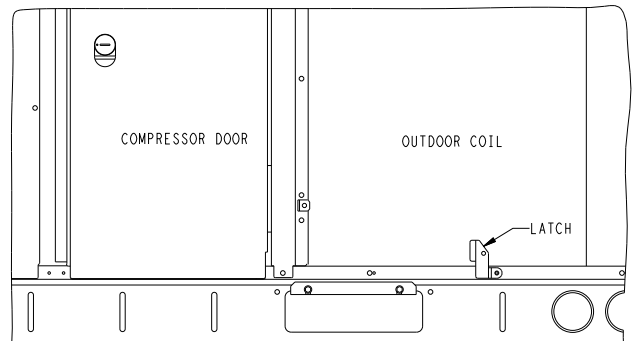
**Fig. 12 - Economizer Filter Installation**

C08634

**Step 9 — Units with Hinged Panels Only**

Relocate latch shipped inside the compressor compartment behind the hinged compressor door to location shown in Fig. 13 after unit installation.

If the unit does not have hinged panels, skip this step and continue at step 10.



**Fig. 13 - Compressor Door Latch Location**

C12101

48KC

## Step 10 — Install Flue Hood

Flue hood is shipped screwed to the basepan beside the burner compartment access panel. Remove from shipping location and using screws provided, install flue hood and screen in location shown in Fig. 14.

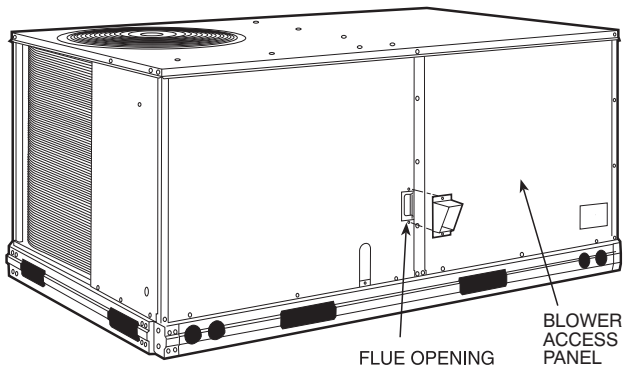


Fig. 14 - Flue Hood Details

C07081

## Step 11 — Install Gas Piping

Installation of the gas piping must be accordance with local building codes and with applicable national codes. In U.S.A., refer to NFPA 54/ANSI Z223.1 National Fuel Gas Code (NFGC). In Canada, installation must be accordance with the CAN/CSA B149.1 and CAN/CSA B149.2 installation codes for gas burning appliances.

This unit is factory equipped for use with Natural Gas fuel at elevations up to 2000 ft (610 m) above sea level. Unit may be field converted for operation at elevations above 2000 ft (610 m) and/or for use with liquefied petroleum fuel. See accessory kit installation instructions regarding these accessories.

**NOTE:** Furnace gas input rate on rating plate is for installation up to 2000 ft (610 m) above sea level. In U.S.A. the input rating for altitudes above 2000 ft (610 m) must be derated by 4% for each 1000 ft (305 m) above sea level. In Canada the input rating must be derated by 10% for altitudes of 2000 ft (610 m) to 4500 ft (1372 m) above sea level.

For natural gas applications, gas pressure at unit gas connection must not be less than 4 in. wg (996 Pa) or greater than 13 in. wg (3240 Pa) while the unit is operating. On 48KCF\*05-06 (high-heat) units, the gas pressure at unit gas connection must not be less than 5 in. wg (1245 Pa) or greater than 13 in. wg (3240 Pa) while the unit is operating. For liquified petroleum applications, the gas pressure must not be less than 11 in. wg (2740 Pa) or greater than 13.6 in. wg (3390 Pa) at the unit connection.

Table 2 – Natural Gas Supply Line Pressure Ranges

UNIT MODEL	UNIT SIZE	MIN	MAX
48KCD/E/L/M/S/R*	04, 05, 06	4.0 in. wg (996 Pa)	13.0 in. wg (3240 Pa)
48KCF/N/T* (High Heat units only)	05, 06	4.0 in. wg (1245 Pa)	13.0 in. wg (3240 Pa)

Table 3 – Liquid Propane Supply Line Pressure Ranges

UNIT MODEL	UNIT SIZE	MIN	MAX
48KCD/E/S/R*	04, 05, 06	11.0 in. wg (2740 Pa)	13.0 in. wg (3240 Pa)
48KCF/T* (High Heat units only)	05, 06	11.0 in. wg (2740 Pa)	13.0 in. wg (3240 Pa)

The gas supply pipe enters the unit at the burner access panel on the front side of the unit, through the long slot at the bottom of the access panel. The gas connection to the unit is made to the 1/2-in. FPT gas inlet port on the unit gas valve

Manifold pressure is factory-adjusted for NG fuel use. Adjust as required to obtain best flame characteristics.

Table 4 – Natural Gas Manifold Pressure Ranges

UNIT MODEL	UNIT SIZE	HIGH FIRE	LOW FIRE
48KCD/E/L/M/S/R*	04, 05, 06	3.5 in. wg (872 Pa)	See NOTE below
48KCF/N/T* (High Heat units only)	05, 06	3.5 in. wg (872 Pa)	See NOTE below
<b>NOTE</b> – LOW FIRE, 1.7 in. Wg (423 Pa), applies to the following three phase voltage units only: 48KCE*04 & 48KCF*05/06			

Manifold pressure for LP fuel use must be adjusted to specified range. Follow instructions in the accessory kit to make initial readjustment.

Table 5 – Liquid Propane Manifold Pressure Ranges

UNIT MODEL	UNIT SIZE	HIGH FIRE	LOW FIRE
48KCD/E/S/R*	04, 05, 06	10.0 in. wg (2490 Pa)	See NOTE below
48KCF/T* (High Heat units only)	05, 06	10.0 in. wg (2490 Pa)	See NOTE below
<b>NOTE</b> – LOW FIRE, 5.0 in. Wg (1245 Pa), applies to the following three phase voltage units only: 48KCE*04 & 48KCF*05/06			

## CAUTION

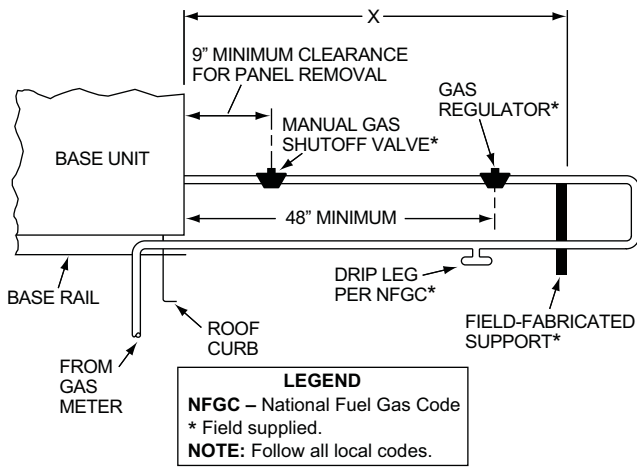
### EQUIPMENT DAMAGE HAZARD

Failure to follow this caution may result in damage to equipment.

When connecting the gas line to the unit gas valve, the installer **MUST** use a backup wrench to prevent damage to the valve.

Install a gas supply line that runs to the unit heating section. Refer to the NFPA 54/NFGC or equivalent code for gas pipe sizing data. Do not use a pipe size smaller than 1/2-in. Size the gas supply line to allow for a maximum pressure drop of 0.5-in wg (124 Pa) between gas regulator source and unit gas valve connection when unit is operating at high-fire flow rate.

The gas supply line can approach the unit in three ways: horizontally from outside the unit (across the roof), thru-curb/under unit basepan (accessory kit required) or through unit basepan (factory-option or accessory kit required). Consult accessory kit installation instructions for details on these installation methods. Observe clearance to gas line components per Fig. 15.

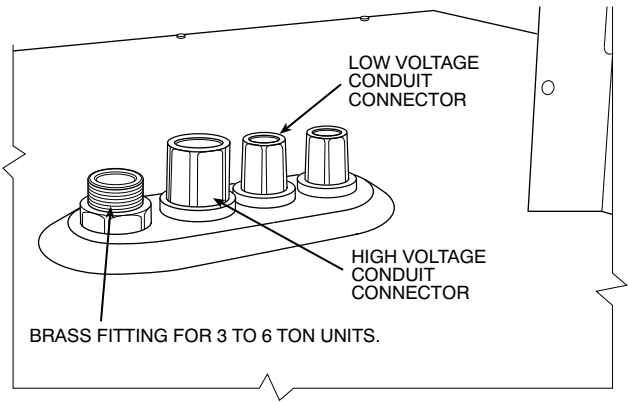


STEEL PIPE NOMINAL DIAMETER (in.)	SPACING OF SUPPORTS X DIMENSION (ft)
1/2	6
3/4 or 1	8
1 1/4 or larger	10

**Fig. 15 - Gas Piping Guide (with Accessory Thru-the-Curb Service Connections)**

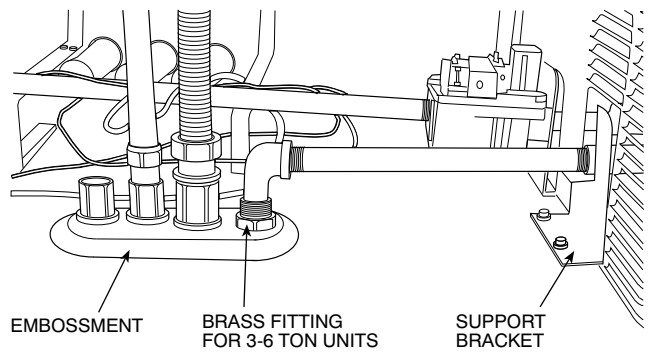
**Factory-Option Thru-Base Connections (Gas Connections)—**

This service connection kit consists of a 1/2-in NPT gas adapter fitting (brass), two 1/2-in electrical bulkhead connector and a 3/4-in electrical bulkhead connector, all factory-installed in the embossed (raised) section of the unit basepan in the condenser section.



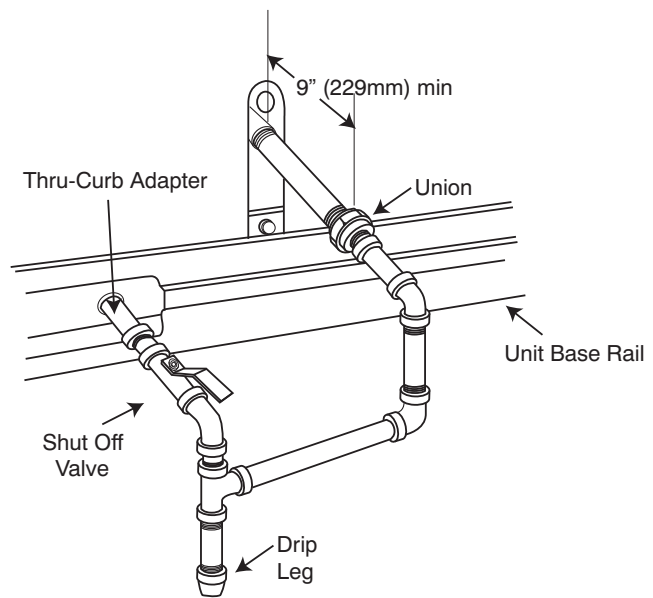
**Fig. 16 - Fittings**

The thru-base gas connector has male and female threads. The male threads protrude above the basepan of the unit; the female threads protrude below the basepan. Check tightness of connector lock nuts before connecting gas piping. Install a 1/2-in NPT street elbow on the thru-base gas fitting. Attach a 1/2-in pipe nipple with minimum length of 16-in (406 mm) (field-supplied) to the street elbow and extend it through the access panel at the gas support bracket. See Fig. 17.



**Fig. 17 - Gas Line Piping for 3 to 5 Ton Units Only**

Other hardware required to complete the installation of the gas supply line will include a manual shutoff valve, a sediment trap (drip leg) and a ground-joint union. A pressure regulator valve may also be required (to convert gas pressure from pounds to inches of pressure). The manual shutoff valve must be located within 6-ft (1.83 m) of the unit. The union, located in the final leg entering the unit, must be located at least 9-in (230 mm) away from the access panel to permit the panel to be removed for service. If a regulator valve is installed, it must be located a minimum of 4-ft (1220 mm) away from the unit's flue outlet. Some municipal codes require that the manual shutoff valve be located upstream of the sediment trap. See Figures 18 and 19 for typical piping arrangements for gas piping that has been routed through the sidewall of the curb. See Fig. 20 for typical piping arrangement when thru-base is used. Ensure that all piping does not block access to the unit's main control box or limit the required working space in front of the control box.



**Fig. 18 - Gas Piping**

48KC

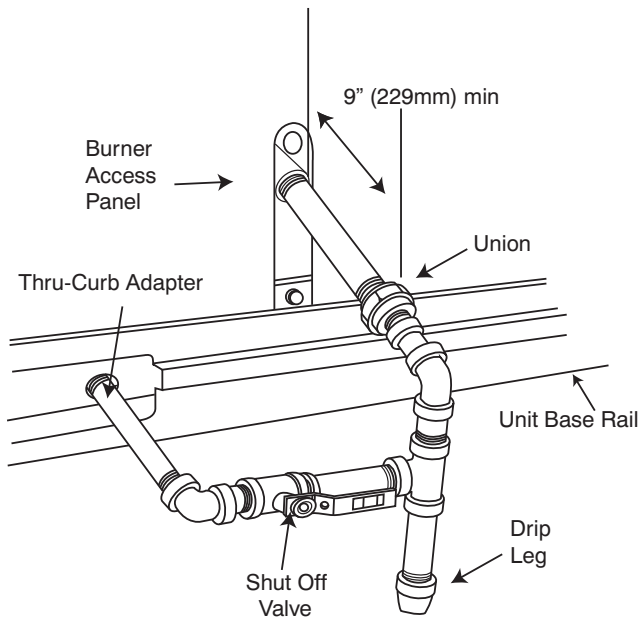


Fig. 19 - Gas Piping

C07470

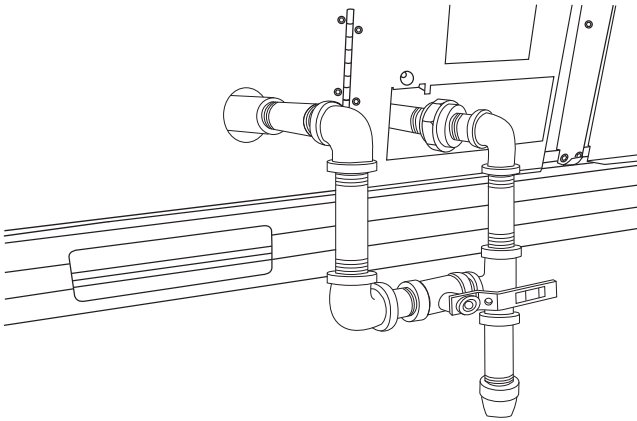


Fig. 20 - Gas Piping Thru-Base Connections

C08018

When installing the gas supply line, observe local codes pertaining to gas pipe installations. Refer to the NFPA 54/ANSI Z223.1 NFGC latest edition (in Canada, CAN/CSA B149.1). In the absence of local building codes, adhere to the following pertinent recommendations:

1. Avoid low spots in long runs of pipe. Grade all pipe  $\frac{1}{4}$ -in. in every 15 ft (7 mm in every 5 m) to prevent traps. Grade all horizontal runs downward to risers. Use risers to connect to heating section and to meter.
2. Protect all segments of piping system against physical and thermal damage. Support all piping with appropriate straps, hangers, etc. Use a minimum of one hanger every 6 ft (1.8 m). For pipe sizes larger than  $\frac{1}{2}$ -in., follow recommendations of national codes.
3. Apply joint compound (pipe dope) sparingly and only to male threads of joint when making pipe connections. Use only pipe dope that is resistant to action of liquefied petroleum gases as specified by local and/or national codes. If using PTFE (Teflon) tape, ensure the material is Double Density type and is labeled for use on gas lines. Apply tape per manufacturer's instructions.

4. Pressure-test all gas piping in accordance with local and national plumbing and gas codes before connecting piping to unit.

**NOTE:** Pressure test the gas supply system after the gas supply piping is connected to the gas valve. The supply piping must be disconnected from the gas valve during the testing of the piping systems when test pressure is in excess of 0.5 psig (3450 Pa). Pressure test the gas supply piping system at pressures equal to or less than 0.5 psig (3450 Pa). The unit heating section must be isolated from the gas piping system by closing the external main manual shutoff valve and slightly opening the ground-joint union. Check for gas leaks at the field-installed and factory-installed gas lines after all piping connections have been completed. Use soap-and-water solution (or method specified by local codes and/or regulations).

## ⚠ WARNING

### FIRE OR EXPLOSION HAZARD

Failure to follow this warning could result in personal injury, death and/or property damage.

- Connect gas pipe to unit using a backup wrench to avoid damaging gas controls.
- Never purge a gas line into a combustion chamber.
- Never test for gas leaks with an open flame. Use a commercially available soap solution made specifically for the detection of leaks to check all connections.
- Use proper length of pipe to avoid stress on gas control manifold.

**NOTE:** If orifice hole appears damaged or it is suspected to have been redrilled, check orifice hole with a numbered drill bit of correct size. Never redrill an orifice. A burr-free and squarely aligned orifice hole is essential for proper flame characteristics.

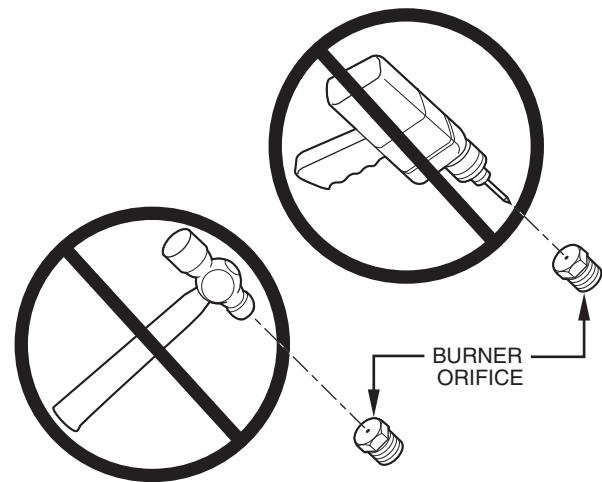


Fig. 21 - Orifice Hole

A93059

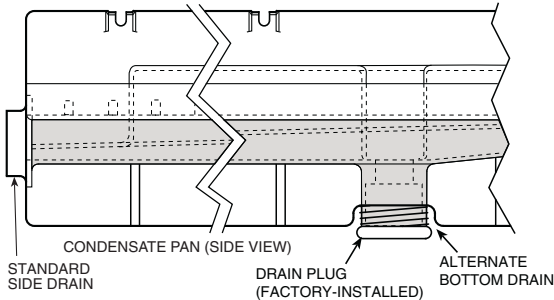


## Step 12 — Install External Condensate Trap and Line

The unit has one  $\frac{3}{4}$ -in. condensate drain connection on the end of the condensate pan and an alternate connection on the bottom. See Fig. 22. Unit airflow configuration does not determine which drain connection to use. Either drain connection can be used with vertical or horizontal applications.

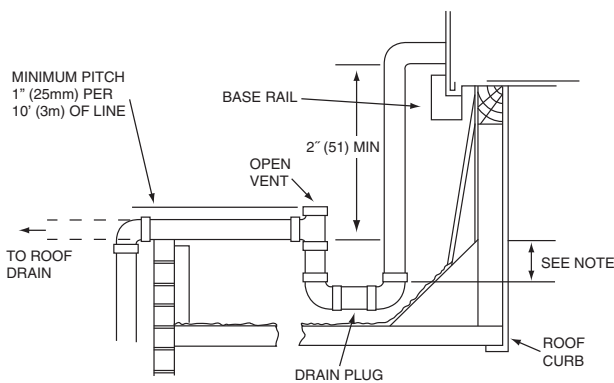
To use the alternate bottom drain connection, remove the red drain plug from the bottom connection (use a  $\frac{1}{2}$ -in. square socket drive extension) and install it in the side drain connection.

The piping for the condensate drain and external trap can be completed after the unit is in place. See Fig. 23.



C08021

**Fig. 22 - Condensate Drain Pan (Side View)**



C08022

**Fig. 23 - Condensate Drain Piping Details**

*All units must have an external trap for condensate drainage. Install a trap at least 4-in. (102 mm) deep and protect against freeze-up. If drain line is installed downstream from the external trap, pitch the line away from the unit at 1-in. per 10 ft (25 mm in 3 m) of run. Do not use a pipe size smaller than the unit connection ( $\frac{3}{4}$ -in.).*

## Step 13 — Make Electrical Connections

### ⚠ WARNING

#### ELECTRICAL SHOCK HAZARD

Failure to follow this warning could result in personal injury or death.

*Do not use gas piping as an electrical ground.* Unit cabinet must have an uninterrupted, unbroken electrical ground to minimize the possibility of personal injury if an electrical fault should occur. This ground may consist of electrical wire connected to unit ground lug in control compartment, or conduit approved for electrical ground when installed in accordance with NEC (National Electrical Code); ANSI/NFPA 70, latest edition (in Canada, Canadian Electrical Code CSA [Canadian Standards Association] C22.1), and local electrical codes.

**NOTE:** Field-supplied wiring shall conform with the limitations of minimum 63°F (33°C) rise.

#### Field Power Supply —

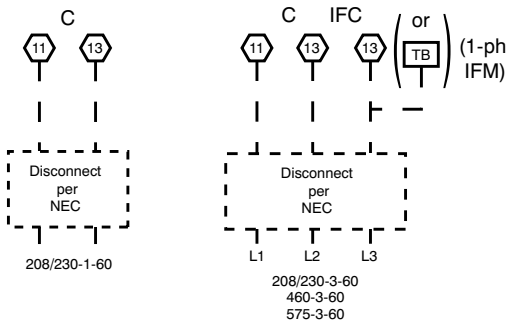
If equipped with optional Powered Convenience Outlet: The power source leads to the convenience outlet's transformer primary are not factory connected. Installer must connect these leads according to required operation of the convenience outlet. If an always-energized convenience outlet operation is desired, connect the source leads to the line side of the unit-mounted disconnect. (Check with local codes to ensure this method is acceptable in your area.) If a de-energize via unit disconnect switch operation of the convenience outlet is desired, connect the source leads to the load side of the unit disconnect. On a unit without a unit-mounted disconnect, connect the source leads to compressor contactor C and indoor fan contactor IFC pressure lugs with unit field power leads.

Refer to Fig. 30 for power transformer connections and the discussion on connecting the convenience outlet on page 15.

Field power wires are connected to the unit at line-side pressure lugs on compressor contactor C and indoor fan contactor IFC (see wiring diagram label for control box component arrangement) or at factory-installed option non-fused disconnect switch. Max wire size is #2 AWG (copper only). See Fig. 24 and unit label diagram for field power wiring connections.

**NOTE:** TEST LEADS - Unit may be equipped with short leads (pigtails) on the field line connection points on contactor C or optional disconnect switch. These leads are for factory run-test purposes only; remove and discard before connecting field power wires to unit connection points. Make field power connections directly to line connection pressure lugs only.

Units Without Non-Fused Disconnect Option



Units With Non-Fused Disconnect Option

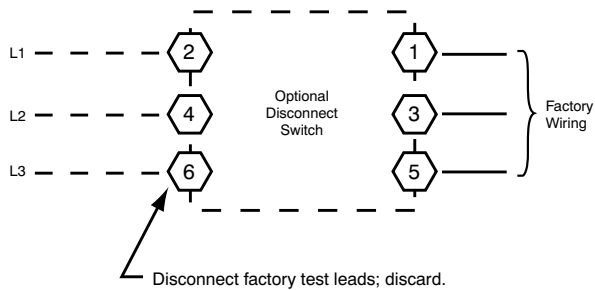


Fig. 24 - Power Wiring Connections

**WARNING**

**FIRE HAZARD**

Failure to follow this warning could result in intermittent operation or performance satisfaction.

Do not connect aluminum wire between disconnect switch and 48KC unit. Use only copper wire. (See Fig. 25.)

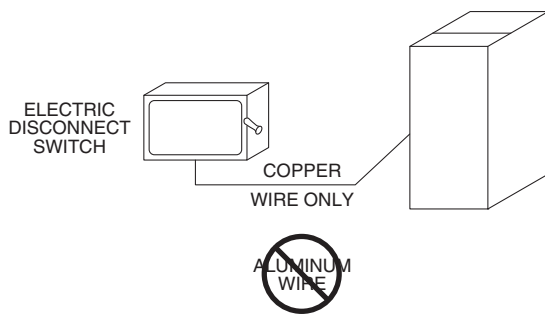
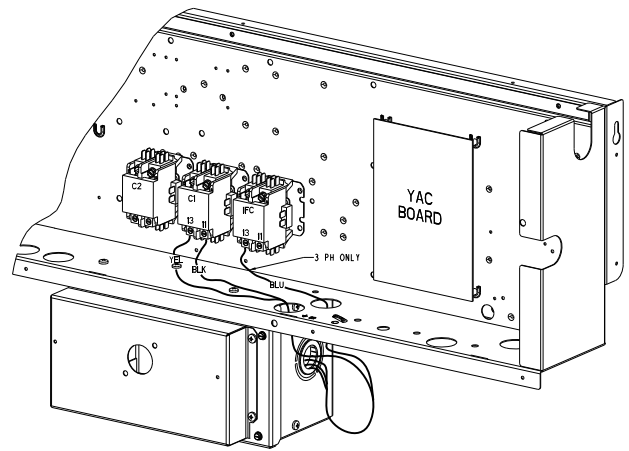


Fig. 25 - Disconnect Switch and Unit

**Units with Factory-Installed Non-Fused Disconnect —**

The factory-installed option non-fused disconnect (NFD) switch is located in a weatherproof enclosure located under the main control box. The manual switch handle and shaft are shipped in the disconnect enclosure. Assemble the shaft and handle to the switch at this point. Discard the factory test leads (see Fig. 24).

Connect field power supply conductors to LINE side terminals when the switch enclosure cover is removed to attach the handle.

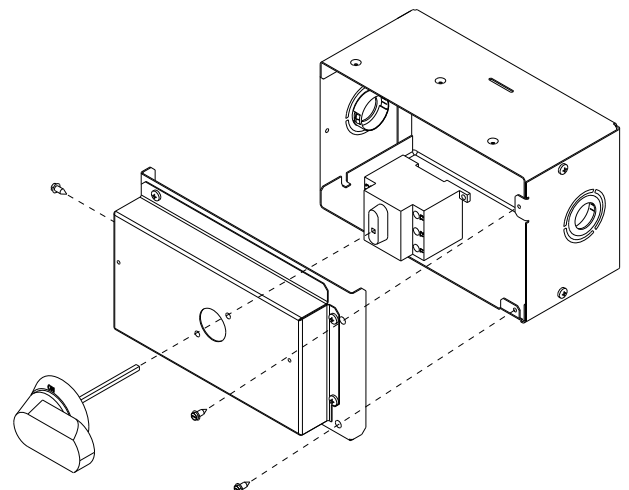


C12278

Fig. 26 - Location of Non-Fused Disconnect Enclosure

**To field install the NFD shaft and handle:**

1. Remove the unit front pane (see Fig. 2).
2. Remove (3) hex screws on the NFD enclosure - (2) on the face of the cover and (1) on the left side cover.
3. Remove the front cover of the NFD enclosure.
4. Make sure the NFD shipped from the factory is at OFF position (the arrow on the black handle knob is at OFF).
5. Insert the shaft with the cross pin on the top of the shaft in the horizontal position.
6. Measure from the tip of the shaft to the top surface of the black pointer; the measurement should be 3.75 - 3.88 in. (95 - 99 mm).
7. Tighten the locking screw to secure the shaft to the NFD.
8. Turn the handle to the OFF position with red arrow pointing at OFF.
9. Install the handle on to the painted cover horizontally with the red arrow pointing to the left.
10. Secure the handle to the painted cover with (2) screws and lock washers supplied.
11. Engaging the shaft into the handle socket, re-install (3) hex screws on the NFD enclosure.
12. Re-install the unit front panel.



C12279

Fig. 27 - Handle and Shaft Assembly for NFD

**Units Without Factory-Installed  
Non-Fused Disconnect —**

When installing units, provide a disconnect switch per NEC (National Electrical Code) of adequate size. Disconnect sizing data is provided on the unit informative plate. Locate on unit cabinet or within sight of the unit per national or local codes. Do not cover unit informative plate if mounting the disconnect on the unit cabinet.

**All Units —**

All field wiring must comply with NEC and all local codes. Size wire based on MCA (Minimum Circuit Amps) on the unit informative plate. See Fig. 24 and the unit label diagram for power wiring connections to the unit power terminal blocks and equipment ground. Maximum wire size is #2 ga AWG (copper only) per pole on contactors.

Provide a ground-fault and short-circuit over-current protection device (fuse or breaker) per NEC Article 440 (or local codes). Refer to unit informative data plate for MOCP (Maximum Over-current Protection) device size.

All field wiring must comply with the NEC and local requirements.

All units except 208/230-v units are factory wired for the voltage shown on the nameplate. *If the 208/230-v unit is to be connected to a 208-v power supply, the control transformer must be rewired by moving the black wire with the 1/4-in. female spade connector from the 230-v connection and moving it to the 200-v 1/4-in. male terminal on the primary side of the transformer.* Refer to unit label diagram for additional information. Field power wires will be connected line-side pressure lugs on the power terminal block or at factory-installed option non-fused disconnect.

**NOTE:** Check all factory and field electrical connections for tightness.

**Convenience Outlets —**

**⚠ WARNING**

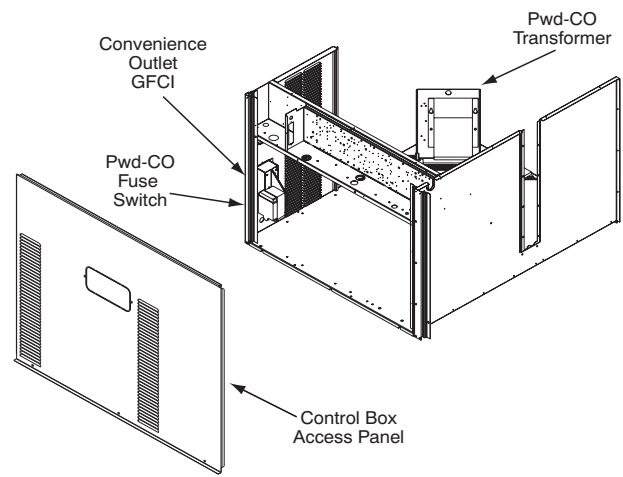
**ELECTRICAL OPERATION HAZARD**

Failure to follow this warning could result in personal injury or death.

Units with convenience outlet circuits may use multiple disconnects. Check convenience outlet for power status before opening unit for service. Locate its disconnect switch, if appropriate, and open it. Lock-out and tag-out this switch, if necessary.

Two types of convenience outlets are offered on 48KC models: Non-powered and unit-powered. Both types provide a 125-volt GFCI (ground-fault circuit-interrupter) duplex receptacle rated at 15-A behind a hinged waterproof access cover, located on the end panel of the unit. See Fig. 28.

**NOTE:** Unit powered convenience outlets are not available as factory installed options for single phase (-3 voltage code) models.



**Fig. 28 - Convenience Outlet Location**

**Installing Weatherproof Cover:** A weatherproof while-in-use cover for the factory-installed convenience outlets is now required by UL standards. This cover cannot be factory-mounted due its depth; it must be installed at unit installation. For shipment, the convenience outlet is covered with a blank cover plate.

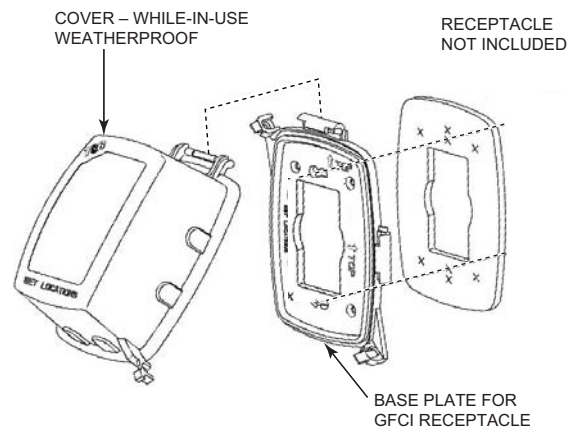
The weatherproof cover kit is shipped in the unit's control box. The kit includes the hinged cover, a backing plate and gasket.

**DISCONNECT ALL POWER TO UNIT AND CONVENIENCE OUTLET. LOCK-OUT AND TAG-OUT ALL POWER.**

Remove the blank cover plate at the convenience outlet; discard the blank cover.

Loosen the two screws at the GFCI duplex outlet, until approximately 1/2-in (13 mm) under screw heads are exposed. Press the gasket over the screw heads. Slip the backing plate over the screw heads at the keyhole slots and align with the gasket; tighten the two screws until snug (do not over-tighten).

Mount the weatherproof cover to the backing plate as shown in Fig. 29. Remove two slot fillers in the bottom of the cover to permit service tool cords to exit the cover. Check for full closing and latching.



**Fig. 29 - Weatherproof Cover Installation**

C08128

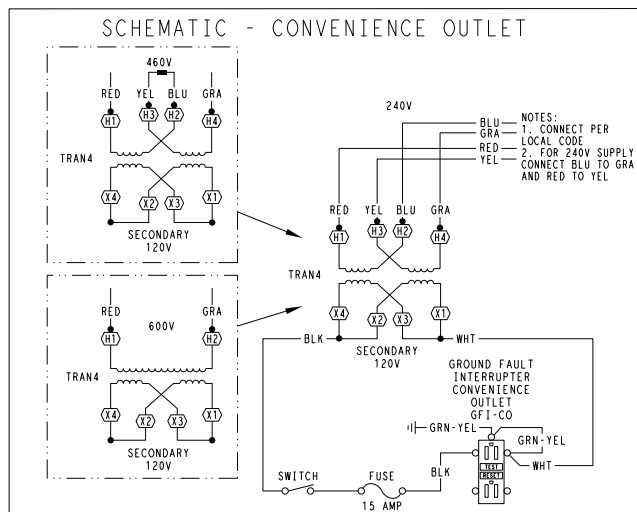
**48KC**

C09022

**Non-powered type:** This type requires the field installation of a general-purpose 125-volt 15-A circuit powered from a source elsewhere in the building. Observe national and local codes when selecting wire size, fuse or breaker requirements and disconnect switch size and location. Route 125-v power supply conductors into the bottom of the utility box containing the duplex receptacle.

**Unit-powered type:** A unit-mounted transformer is factory-installed to stepdown the main power supply voltage to the unit to 115-v at the duplex receptacle. This option also includes a manual switch with fuse, located in a utility box and mounted on a bracket behind the convenience outlet; access is through the unit's control box access panel. See Fig. 28.

The primary leads to the convenience outlet transformer are not factory-connected. Selection of primary power source is a customer-option. If local codes permit, the transformer primary leads can be connected at the line-side terminals on the unit-mounted non-fused disconnect switch; this will provide service power to the unit when the unit disconnect switch is open. Other connection methods will result in the convenience outlet circuit being de-energized when the unit disconnect switch is open. See Fig. 30.



C08283

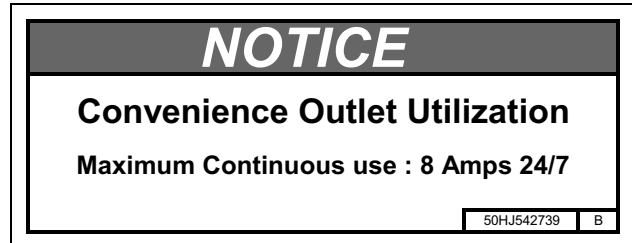
UNIT VOLTAGE	CONNECT AS	PRIMARY CONNECTIONS	TRANSFORMER TERMINALS
208, 230	240	L1: RED +YEL L2: BLU + GRA	H1 + H3 H2 + H4
460	480	L1: RED Splice BLU + YEL L2: GRA	H1 H2 + H3 H4
575	600	L1: RED L2: GRA	H1 H2

**Fig. 30 - Powered Convenience Outlet Wiring**

**Using unit-mounted convenience outlets:** Units with unit-mounted convenience outlet circuits will often require that two disconnects be opened to de-energize all power to the unit. Treat all units as electrically energized until the convenience outlet power is also checked and de-energization is confirmed. Observe National Electrical

Code Article 210, Branch Circuits, for use of convenience outlets.

**Fuse on power type:** The factory fuse is a Bussman "Fusetron" T-15, non-renewable screw-in (Edison base) type plug fuse.



C13415

**Fig. 31 - Convenience Outlet Utilization Notice Label**

**Duty Cycle:** the unit-powered convenience outlet has a duty cycle limitation. The transformer is intended to provide power on an intermittent basis for service tools, lamps, etc; it is not intended to provide 15-amps loading for continuous duty loads (such as electric heaters for overnight use). Observe a 50% limit on circuit loading above 8-amps.

**Convenience outlet usage rating:**

Continuous usage: 8 amps maximum

Test the GFCI receptacle by pressing the TEST button on the face of the receptacle to trip and open the receptacle. Check for proper grounding wires and power line phasing if the GFCI receptacle does not trip as required. Press the RESET button to clear the tripped condition.

**Factory-Option Thru-Base Connections (Electrical Connections) —**

This service connection kit consists of a 1/2-in NPT gas adapter fitting (brass), a 1/2-in electrical bulkhead connector and a 3/4-in electrical bulkhead connector, all factory-installed in the embossed (raised) section of the unit basepan in the condenser section. The 3/4-in bulkhead connector enables the low-voltage control wires to pass through the basepan. The 1/2-in electrical bulkhead connector allows the high-voltage power wires to pass through the basepan. See Fig. 16.

Check tightness of connector lock nuts before connecting electrical conduits.

Field-supplied and field-installed liquid tight conduit connectors and conduit may be attached to the connectors on the basepan. Pull correctly rated high voltage and low voltage through appropriate conduits. Connect the power conduit to the internal disconnect (if unit is so equipped) or to the external disconnect (through unit side panel). A hole must be field cut in the main control box bottom on the left side so the 24-v control connections can be made. Connect the control power conduit to the unit control box at this hole.

### Units without Thru-Base Connections —

1. Install power wiring conduit through side panel openings. Install conduit between disconnect and control box.
2. Install power lines to terminal connections as shown in Fig. 24.

Voltage to compressor terminals during operation must be within voltage range indicated on unit nameplate. See Table 13. On 3-phase units, voltages between phases must be balanced within 2% and the current within 10%. Use the formula shown in the legend for Table 13, Note 2 (on page 48) to determine the percent of voltage imbalance. Operation on improper line voltage or excessive phase imbalance constitutes abuse and may cause damage to electrical components. Such operation would invalidate any applicable Carrier warranty.

### Field Control Wiring —

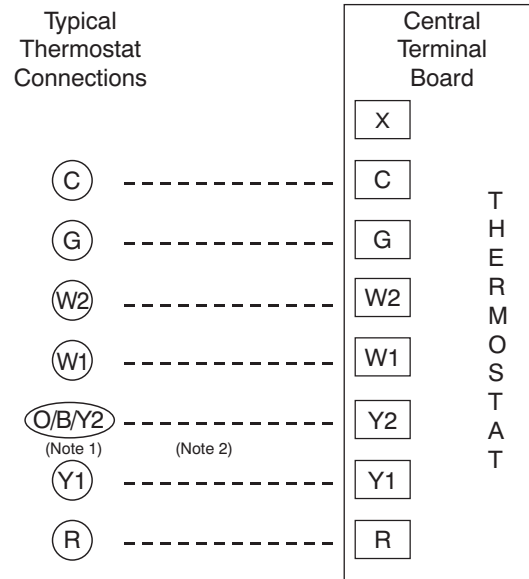
The 48KC unit requires an external temperature control device. This device can be a thermostat (field-supplied) or a PremierLink controller (available as factory-installed option or as field-installed accessory, for use on a Carrier Comfort Network or as a stand alone control) or the RTU Open Controller for Building Management Systems using non-CCN protocols (RTU Open is available as a factory-installed option only).

### Thermostat —

Install a Carrier-approved accessory thermostat according to installation instructions included with the accessory. For complete economizer function, select a two-stage cooling thermostat. Locate the thermostat accessory on a solid wall in the conditioned space to sense average temperature in accordance with the thermostat installation instructions.

If the thermostat contains a logic circuit requiring 24-v power, use a thermostat cable or equivalent single leads of different colors with minimum of seven leads. If the thermostat does not require a 24-v source (no “C” connection required), use a thermostat cable or equivalent with minimum of six leads. Check the thermostat installation instructions for additional features which might require additional conductors in the cable.

For wire runs up to 50 ft. (15 m), use no. 18 AWG (American Wire Gage) insulated wire [35°C (95°F) minimum]. For 50 to 75 ft. (15 to 23 m), use no. 16 AWG insulated wire [35°C (95°F) minimum]. For over 75 ft. (23 m), use no. 14 AWG insulated wire [35°C (95°F) minimum]. All wire sizes larger than no. 18 AWG cannot be directly connected to the thermostat and will require a junction box and splice at the thermostat.



Note 1: Typical multi-function marking. Follow manufacturer's configuration Instructions to select Y2.

Note 2: Y2 to Y2 connection required on single-stage cooling units when integrated economizer function is desired.

--- Field Wiring

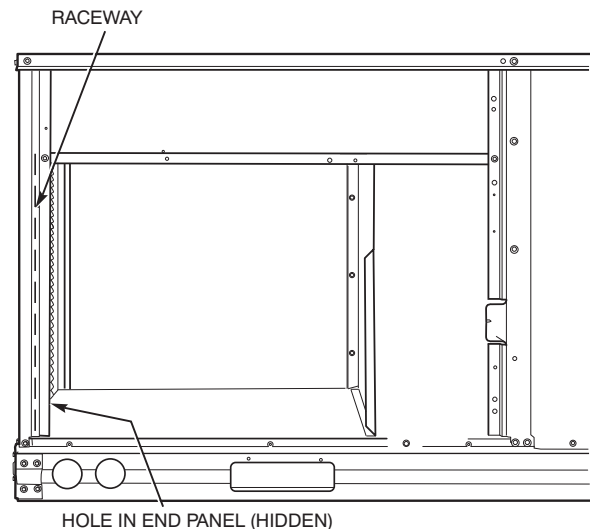
C08069

Fig. 32 - Low-Voltage Connections

### Unit without Thru-Base Connection Kit —

Pass the thermostat control wires through the hole provided in the corner post; then feed the wires through the raceway built into the corner post to the control box. Pull the wires over to the terminal strip on the upper-left corner of the Controls Connection Board. See Fig. 33.

**NOTE:** If thru-the-bottom connections accessory is used, refer to the accessory installation instructions for information on routing power and control wiring.



C08027

Fig. 33 - Field Control Wiring Raceway

### Heat Anticipator Settings —

Set heat anticipator settings at 0.14 amp for the first stage and 0.14 amp for second-stage heating, when available.

48KC

## Humidi-MiZer® Control Connections

### Humidi-MiZer – Space RH Controller —

**NOTE:** The Humidi-MiZer is a factory installed option which is only available for units equipped with belt-drive motors. Humidi-MiZer is not available for single phase (-3 voltage code) models.

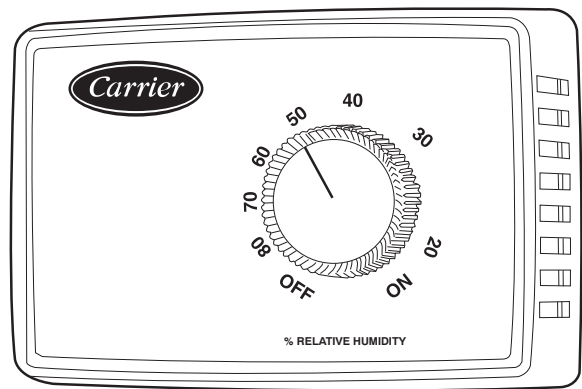
The Humidi-MiZer dehumidification system requires a field-supplied and -installed space relative humidity control device. This device may be a separate humidistat control (contact closes on rise in space RH above control setpoint) or a combination thermostat-humidistat control device such as Carrier's EDGE® Pro Thermidistat with isolated contact set for dehumidification control. The humidistat is normally used in applications where a temperature control is already provided (units with PremierLink™ control).

#### To connect the Carrier humidistat (HL38MG029):

1. Route the humidistat 2-conductor cable (field-supplied) through the hole provided in the unit corner post.
2. Feed wires through the raceway built into the corner post (see Fig. 33) to the 24-v barrier located on the left side of the control box. The raceway provides the UL-required clearance between high-voltage and low-voltage wiring.
3. Use wire nuts to connect humidistat cable to two PINK leads in the low-voltage wiring as shown in Fig. 36.

#### To connect the Thermidistat device (33CS2PPRH-03):

1. Route the Thermidistat multi-conductor thermostat cable (field-supplied) through the hole provided in the unit corner post.
2. Feed wires through the raceway built into the corner post (see Fig. 33) to the 24-v barrier located on the left side of the control box. The raceway provides the UL-required clearance between high-voltage and low-voltage wiring.
3. The Thermidistat has dry contacts at terminals D1 and D2 for dehumidification operation (see Fig. 37). The dry contacts must be wired between CTB terminal R and the PINK lead to the LTLO switch with field-supplied wire nuts. Refer to the installation instructions included with the Carrier Edge Thermidistat device (Form 33CS-74SI or latest) for more information.



C09295

Fig. 34 - Accessory Field-Installed Humidistat



C09296

Fig. 35 - EDGE Pro Thermidistat

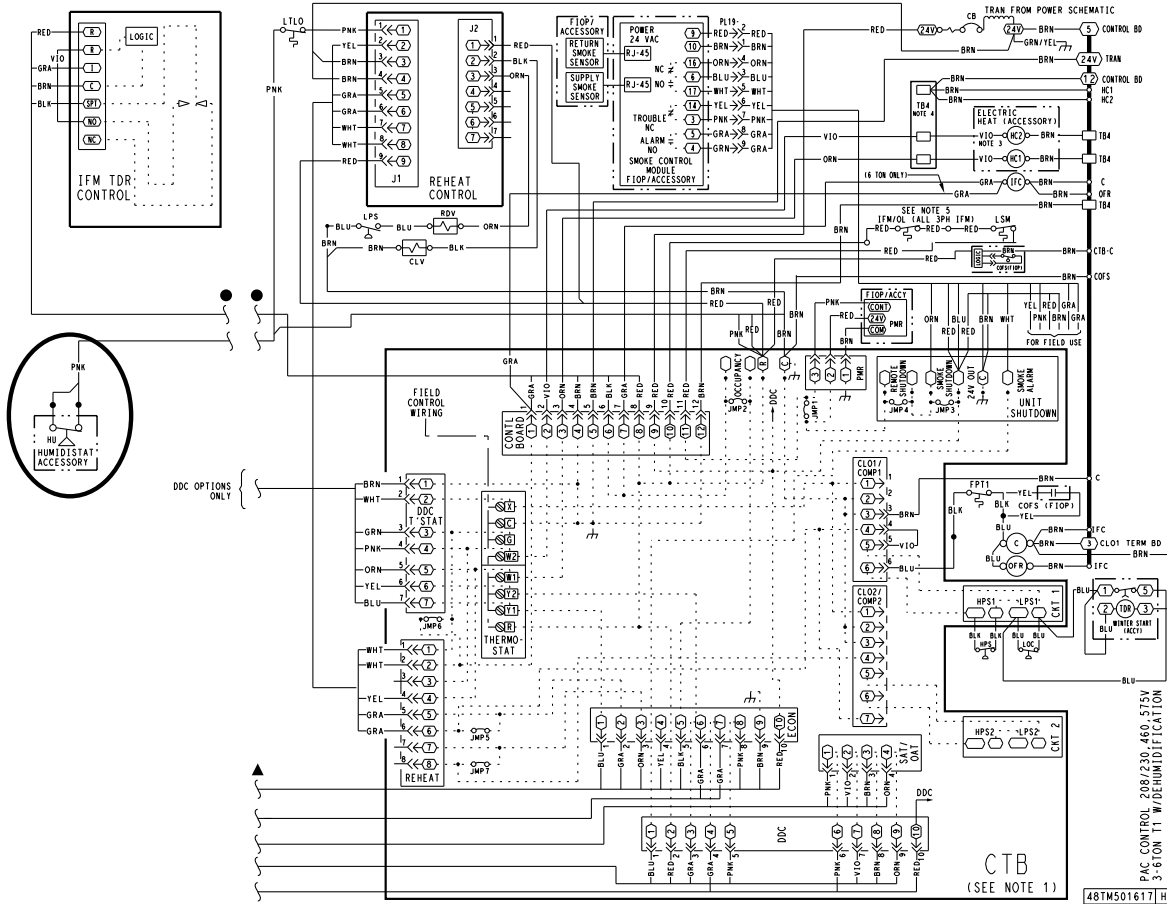


Fig. 36 - Typical Humidi-MiZer® Adaptive Dehumidification System Humidistat Wiring

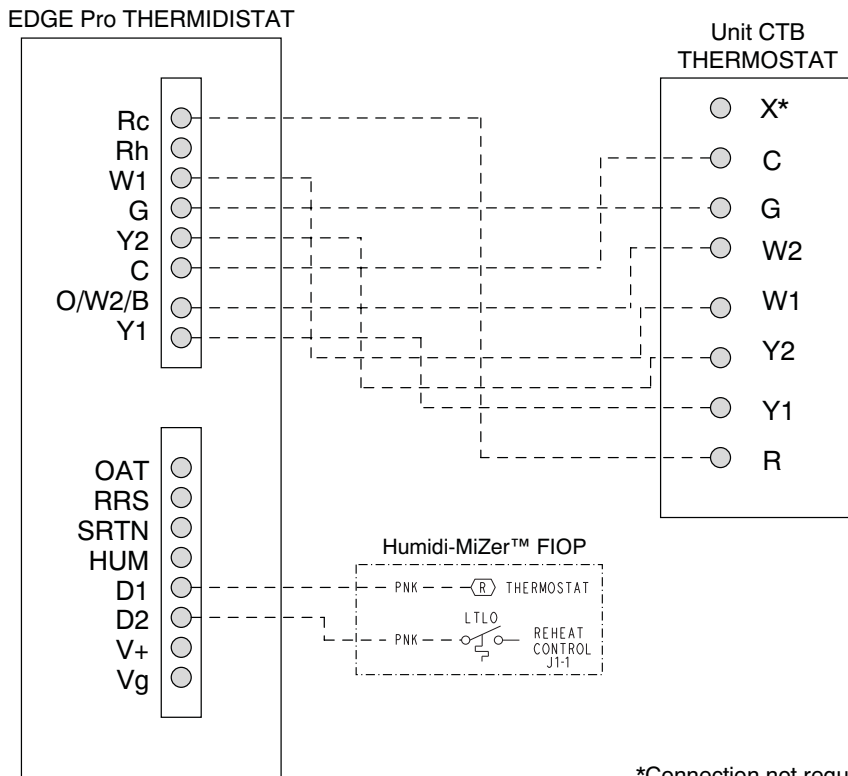


Fig. 37 - Typical Rooftop Unit with Humidi-MiZer Adaptive Dehumidification System with EDGE Pro Thermidistat Device

48KC

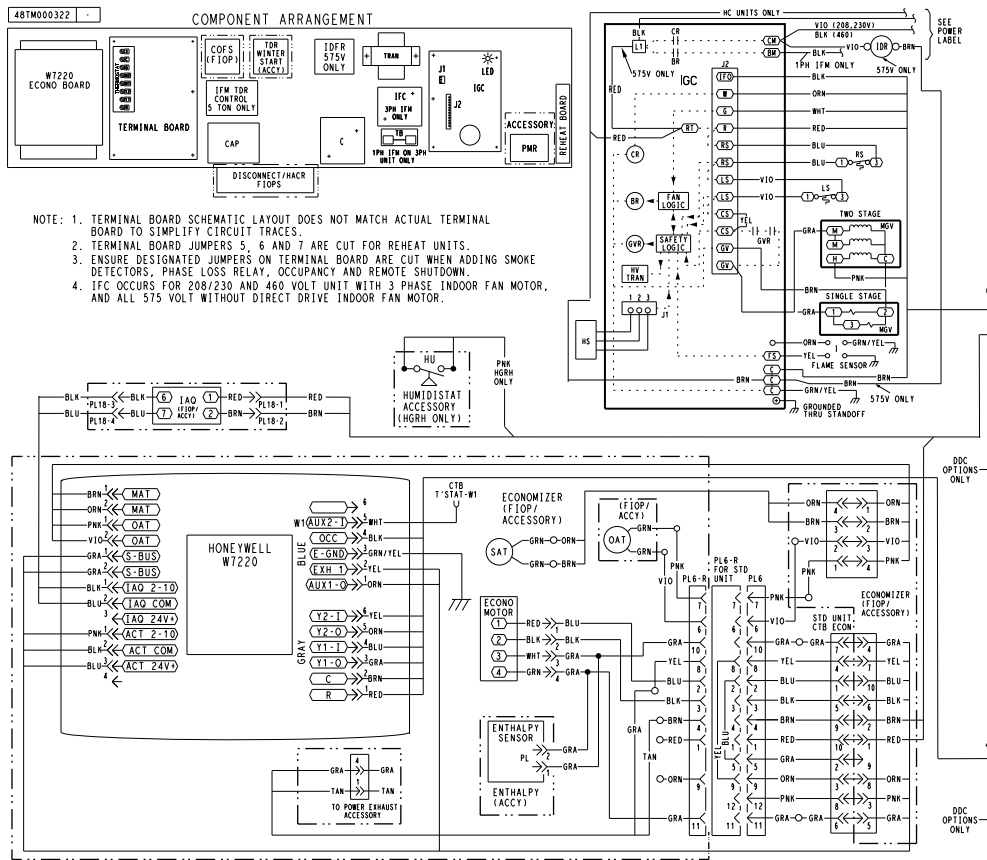
C14242

C09298

# EconoMiSer® X (Factory-Installed Option)

For details on operating 48KC units equipped with the factory-installed EconoMiSer X option, refer to *Factory-Installed Economizers for TC/TCQ/HC/HCQ/LC/KC/KCQ Rooftop Units, 3 to 27.5 Nominal Tons. Economizer Supplement Related to California Title 24* (Catalog No. SUP-TI24-02SI, or later).

48KC

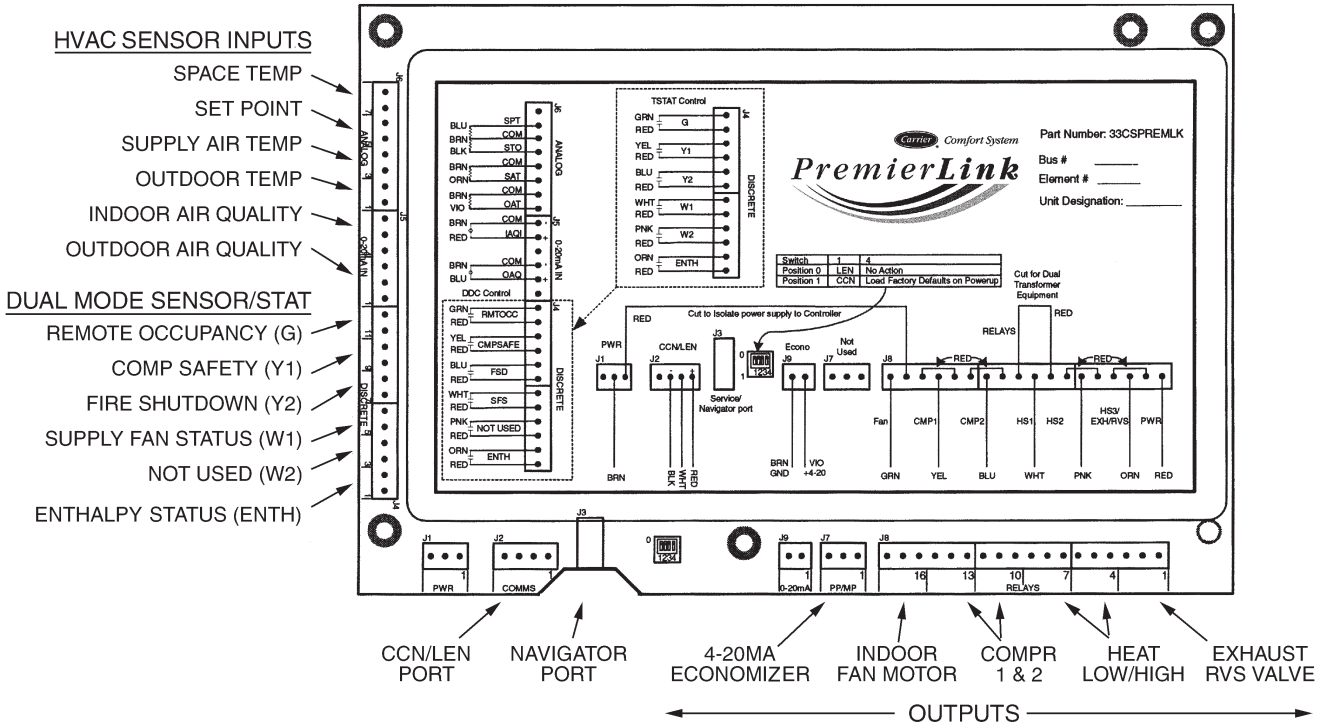


**Fig. 38 - EconoMiSer X W7220 Controller Wiring Diagram**

C14243



**PremierLink™ (Factory-Option)**



48KC

**Fig. 39 - PremierLink Controller**

C08199

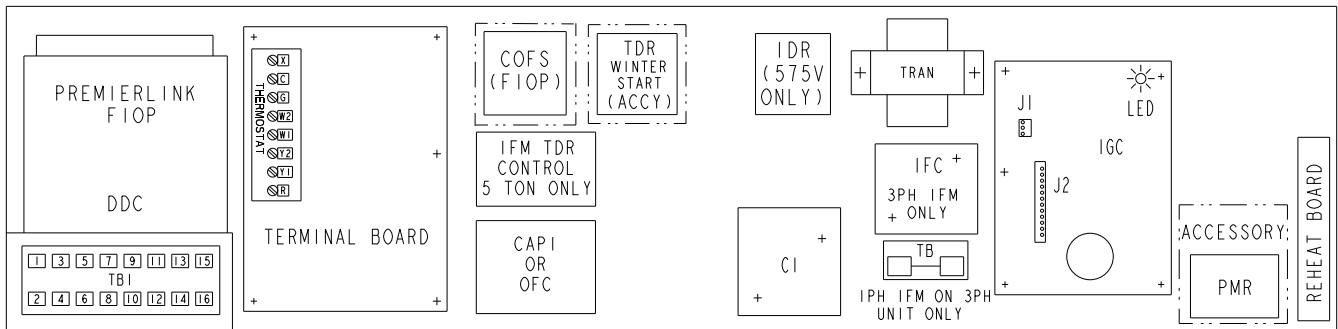
The PremierLink controller (see Fig. 39) is compatible with Carrier Comfort Network® (CCN) devices. This control is designed to allow users the access and ability to change factory-defined settings, thus expanding the function of the standard unit control board. CCN service access tools include System Pilot™, Touch Pilot™ and Service Tool. (Standard tier display tools Navigator™ and Scrolling Marquee are not suitable for use with latest PremierLink controller (Version 2.x).)

The PremierLink control is factory-mounted in the 48KC unit's main control box to the left of the Central Terminal Board (CTB) (see Fig. 40). Factory wiring is completed through harnesses connected to the CTB thermostat. Field connections are made at a 16-pole terminal block (TB1) located on the bottom shelf of the unit control box in front

of the PremierLink controller. The factory-installed PremierLink control includes the supply-air temperature (SAT) sensor. The outdoor air temperature (OAT) sensor is included in the FIOP/accessory EconoMi\$er® 2 package.

The PremierLink controller requires the use of a Carrier electronic thermostat or a CCN connection for time broadcast to initiate its internal timeclock. This is necessary for broadcast of time of day functions (occupied/unoccupied).

**NOTE:** PremierLink controller is shipped in Sensor mode. To be used with a thermostat, the PremierLink controller must be configured to Thermostat mode. Refer to PremierLink Configuration instructions for Operating Mode.



**Fig. 40 - 48KC Control Box – PremierLink Location**

C14244

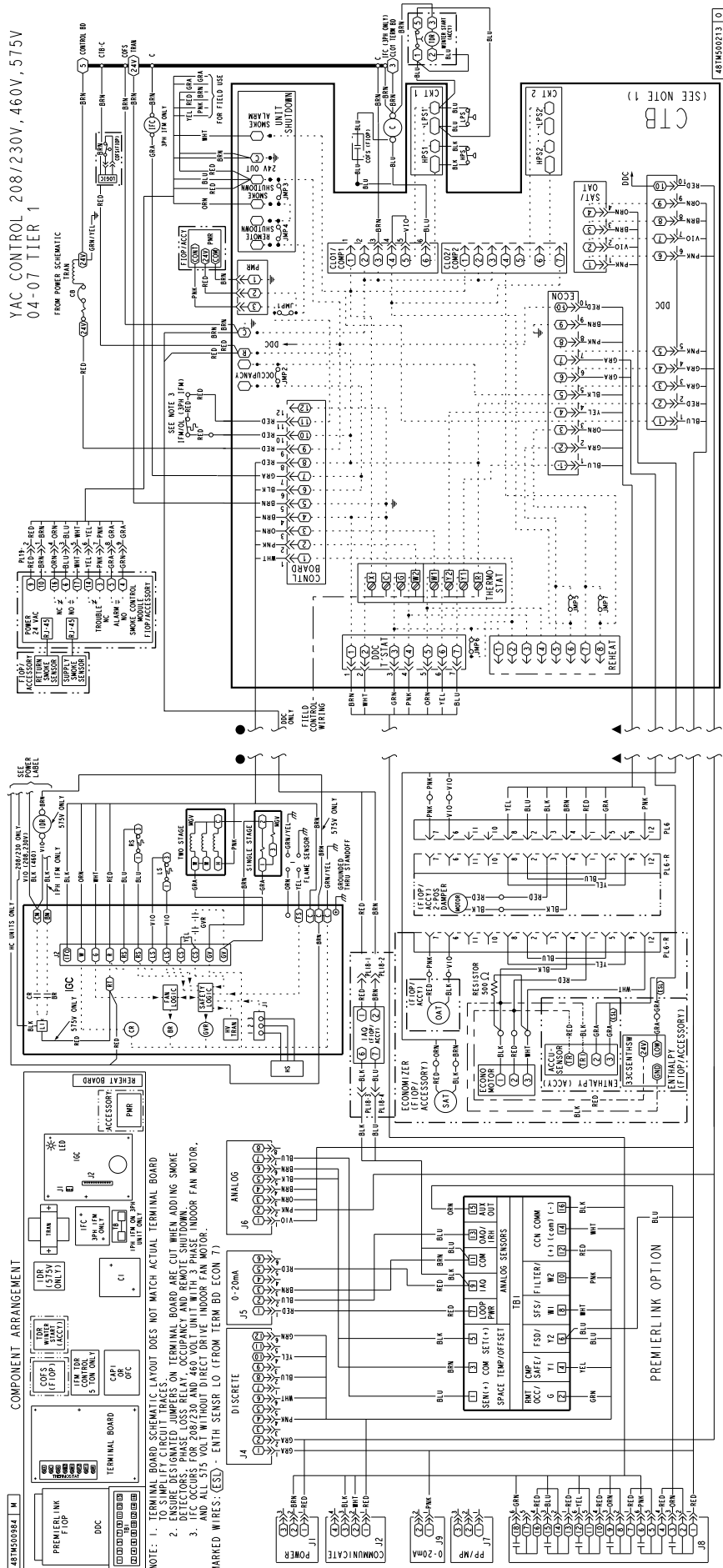


Fig. 41 - PremierLink Wiring Schematic

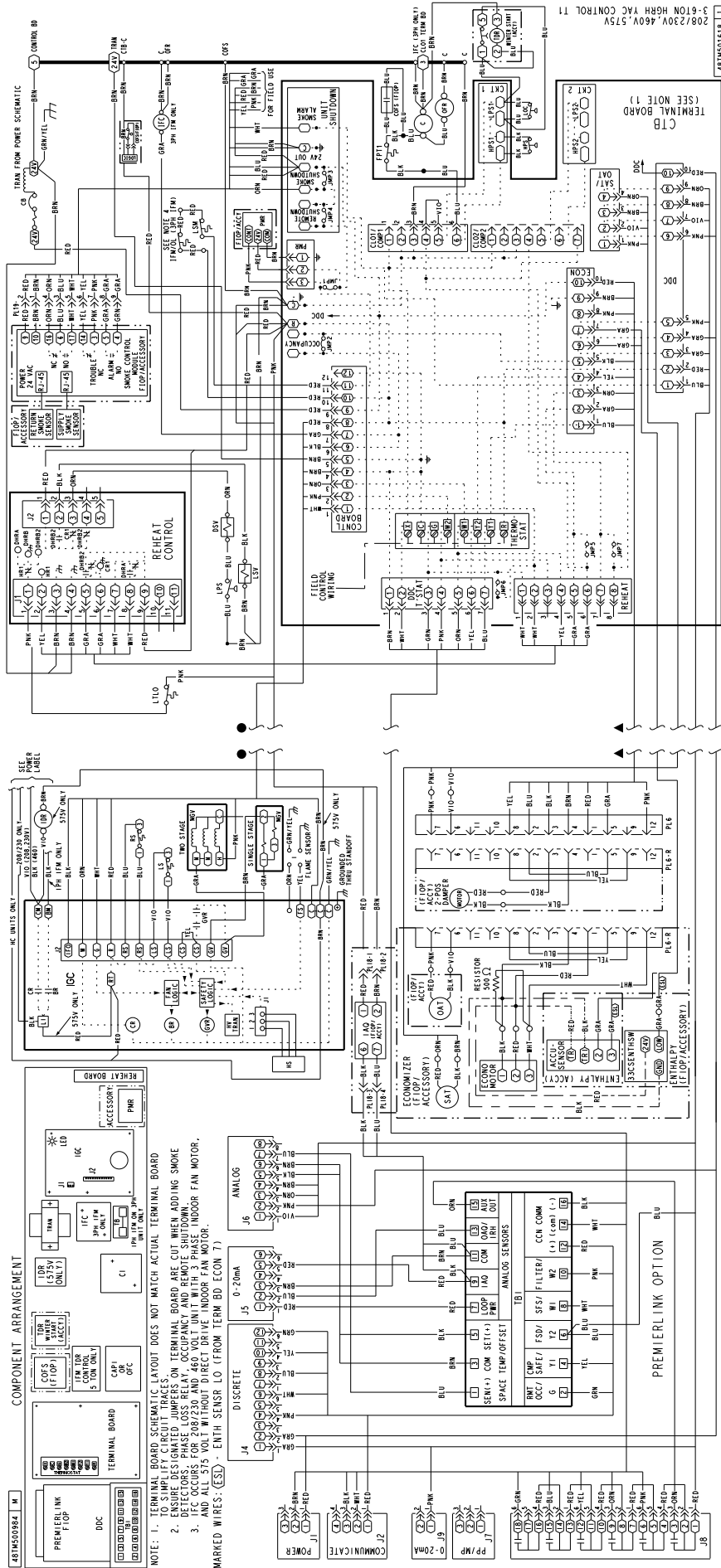
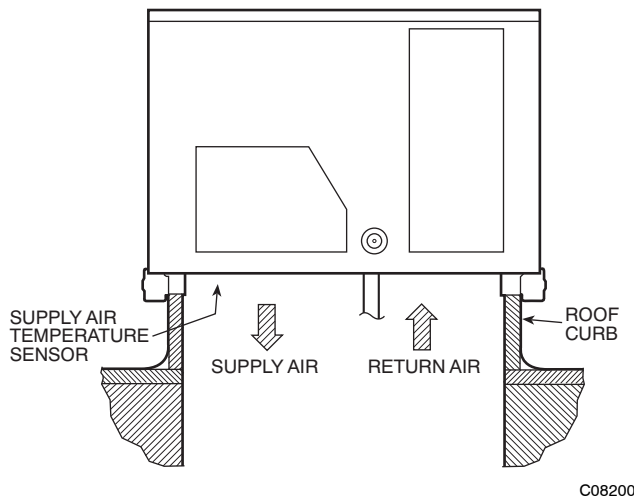


Fig. 42 - PremierLink Wiring Schematic with Humidi-MiZer®

### Supply Air Temperature (SAT) Sensor —

On FIOP-equipped 48KC unit, the unit is supplied with a supply-air temperature (SAT) sensor (33ZCSENSAT). This sensor is a tubular probe type, approx 6-inches (152 mm) in length. It is a nominal 10-k ohm thermistor.

The SAT is factory-wired. The SAT probe is wire-tied to the supply-air opening (on the horizontal opening end) in its shipping position. Remove the sensor for installation. Re-position the sensor in the flange of the supply-air opening or in the supply air duct (as required by local codes). Drill or punch a 1/2-in. hole in the flange or duct. Use two field-supplied, self-drilling screws to secure the sensor probe in a horizontal orientation. See Fig. 43.



**Fig. 43 - Typical Mounting Location for Supply Air Temperature (SAT) Sensor on Small Rooftop Units**

**NOTE:** Refer to Form 33CS-68SI for complete PremierLink configuration, operating sequences and troubleshooting information. Have a copy of this manual available at unit start-up.

**NOTE:** The sensor must be mounted in the discharge airstream downstream of the cooling coil and any heating devices. Be sure the probe tip does not come in contact with any of the unit’s heater surfaces.

### Outdoor Air Temperature (OAT) Sensor —

The OAT is factory-mounted in the EconoMiSer®2 (FIOP or accessory). It is a nominal 10k ohm thermistor attached to an eyelet mounting ring.

### EconoMiSer2 —

The PremierLink™ control is used with EconoMiSer2 (option or accessory) for outdoor air management. The damper position is controlled directly by the PremierLink control; EconoMiSer2 has no internal logic device.

Outdoor air management functions can be enhanced with field-installation of these accessory control devices:

- Enthalpy control (outdoor air or differential sensors)
- Space CO<sub>2</sub> sensor
- Outdoor air CO<sub>2</sub> sensor

Refer to Table 6 for accessory part numbers.

### Field Connections

Field connections for accessory sensor and input devices are made at the 16-pole terminal block (TB1) located on the control box bottom shelf in front of the PremierLink control (See Figs. 41 and 42). Some input devices also require a 24-vac signal source; connect at CTB terminal R at “THERMOSTAT” connection strip for this signal source. See connections figures on following pages for field connection locations (and for continued connections at the PremierLink board inputs).

Table 7 provides a summary of field connections for units equipped with Space Sensor. Table 8 provides a summary of field connections for units equipped with Space Thermostat.

**Table 6 – PremierLink Sensor Usage**

APPLICATION	OUTDOOR AIR TEMPERATURE SENSOR	RETURN AIR TEMPERATURE SENSOR	OUTDOOR AIR ENTHALPY SENSOR	RETURN AIR ENTHALPY SENSOR
Differential Dry Bulb Temperature with PremierLink (PremierLink requires 4–20 mA Actuator)	Included – CRTEMPN001A00	Required – 33ZCT55SPT or equivalent	–	–
Single Enthalpy with PremierLink (PremierLink requires 4–20mA Actuator)	Included – Not Used	–	Requires – 33CSENTHSW	–
Differential Enthalpy with PremierLink (PremierLink requires 4–20mA Actuator)	Included – Not Used	–	Requires – 33CSENTHSW or equivalent	Requires – 33CSENTSEN or equivalent

**NOTES:**

CO<sub>2</sub> Sensors (Optional):

- 33ZCSENC02 – Room sensor (adjustable). Aspirator box is required for duct mounting of the sensor.
- 33ZCASPC02 – Aspirator box used for duct-mounted CO<sub>2</sub> room sensor.
- 33ZCT55CO2 – Space temperature and CO<sub>2</sub> room sensor with override.
- 33ZCT56CO2 – Space temperature and CO<sub>2</sub> room sensor with override and setpoint.

**Table 7 – Space Sensor Mode**

TB1 TERMINAL	FIELD CONNECTION	INPUT SIGNAL
1	T55 – SEN/T56 – SEN	Analog (10k thermistor)
2	RMTOCC	Discrete, 24VAC
3	T55 – SEN/T56 – SEN	Analog (10k thermistor)
4	CMPSAFE	Discrete, 24VAC
5	T56 – SET	Analog (10k thermistor)
6	FSD	Discrete, 24VAC
7	LOOP – PWR	Analog, 24VDC
8	SPS	Discrete, 24VAC
9	IAQ – SEN	Analog, 4 – 20mA
10	FILTER	Discrete, 24VAC
11	IAQ – COM/OAQ – COM/RH – COM	Analog, 4 – 20mA
12	CCN + (RED)	Digital, , 5VDC
13	OAQ – SEN/RH – SEN	Analog, 4 – 20mA
14	CCN Gnd (WHT)	Digital, 5VDC
15	AUX OUT (Power Exhaust)	(Output) Discrete 24VAC
16	CCN – (BLK)	Digital, 5VDC

**LEGEND:**

- |         |   |     |  |
|---------|---|-----|--|
| T55     | – Space Temperature Sensor                    | FSD | – Fire Shutdown                          |
| T56     | – Space Temperature Sensor                    | IAQ | – Indoor Air Quality (CO <sub>2</sub> )  |
| CCN     | – Carrier Comfort Network (communication bus) | OAQ | – Outdoor Air Quality (CO <sub>2</sub> ) |
| CMPSAFE | – Compressor Safety                           | RH  | – Relative Humidity                      |
| FILTER  | – Dirty Filter Switch                         | SFS | – Supply Fan Status                      |

**Table 8 – Thermostat Mode**

TB1 TERMINAL	FIELD CONNECTION	INPUT SIGNAL
1	RAT SEN	Analog (10k thermistor)
2	G	Discrete, 24VAC
3	RAT SEN	Analog (10k thermistor)
4	Y1	Discrete, 24VAC
5		
6	Y2	Discrete, 24VAC
7	LOOP – PWR	Analog, 24VDC
8	W1	Discrete, 24VAC
9	IAQ – SEN	Analog, 4 – 20mA
10	W2	Discrete, 24VAC
11	IAQ – COM/OAQ – COM/RH – COM	Analog, 4 – 20mA
12	CCN + (RED)	Digital, 5VDC
13	OAQ – SEN/RH – SEN	Analog, 4 – 20mA
14	CCN Gnd (WHT)	Digital, 5VDC
15	AUX OUT (Power Exhaust)	(Output) Discrete 24VAC
16	CCN – (BLK)	Digital, 5VDC

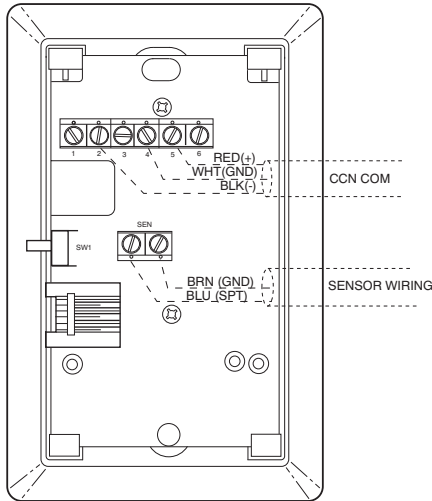
**LEGEND:**

- |     |   |    |                           |
|-----|---|----|---------------------------|
| CCN | – Carrier Comfort Network (communication bus) | RH | – Relative Humidity       |
| G   | – Thermostat Fan                              | W1 | – Thermostat Heat Stage 1 |
| IAQ | – Indoor Air Quality (CO <sub>2</sub> )       | W2 | – Thermostat Heat Stage 2 |
| OAQ | – Outdoor Air Quality (CO <sub>2</sub> )      | Y1 | – Thermostat Cool Stage 1 |
| RAT | – Return Air Temperature                      | Y2 | – Thermostat Cool Stage 2 |

48KC

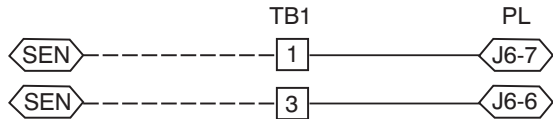
## Space Sensors —

The PremierLink controller is factory-shipped configured for Space Sensor Mode. A Carrier T-55 or T-56 space sensor must be used. T-55 space temperature sensor provides a signal of space temperature to the PremierLink control. T-56 provides same space temperature signal plus it allows for adjustment of space temperature setpoints from the face of the sensor by the occupants.



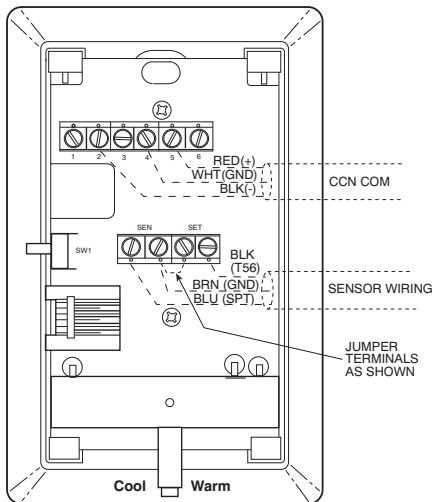
**Fig. 44 - T-55 Space Temperature Sensor Wiring**

**Connect T-55:** See Fig. 44 for typical T-55 internal connections. Connect the T-55 SEN terminals to TB1 terminals 1 and 3 (see Fig. 45).

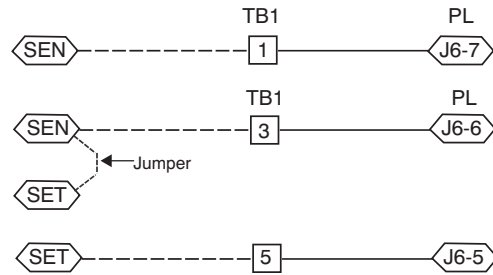


**Fig. 45 - PremierLink T-55 Sensor**

**Connect T-56:** See Fig. 46 for T-56 internal connections. Install a jumper between SEN and SET terminals as illustrated. Connect T-56 terminals to TB1 terminals 1, 3 and 5 (see Fig. 47).



**Fig. 46 - T-56 Internal Connections**

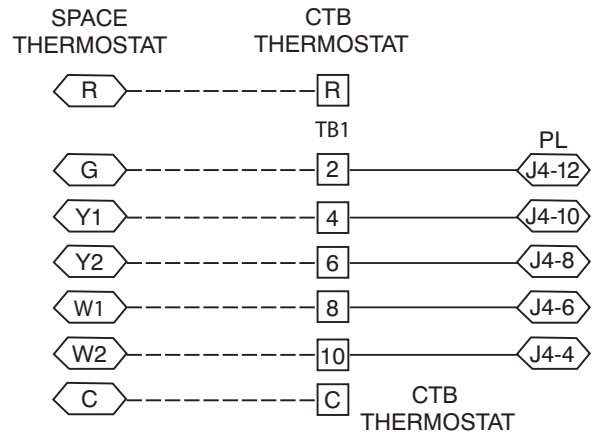


**Fig. 47 - PremierLink T-56 Sensor**

## Connect Thermostat —

A 7-wire thermostat connection requires a 24-v power source and a common connection. Use the R and C terminals on the CTB's THERMOSTAT connection strip for these. Connect the thermostat's Y1, Y2, W1, W2 and G terminals to PremierLink TB1 as shown in Fig. 48.

If the 48KC unit is equipped with factory-installed smoke detector(s), disconnect the factory BLU lead at TB1-6 (Y2) before connecting the thermostat. Identify the BLU lead originating at CTB-DDC-1; disconnect at TB1-6 and tape off. Confirm that the second BLU lead at TB1-6 remains connected to PremierLink J4-8.



**Fig. 48 - Space Thermostat Connections**

If the 48KC unit has an economizer system and free-cooling operation is required, a sensor representing Return Air Temperature must also be connected (field-supplied and installed). This sensor may be a T-55 Space Sensor (see Fig. 44) installed in the space or in the return duct, or it may be sensor PNO 33ZCSENSAT, installed in the return duct. Connect this sensor to TB1-1 and TB1-3 per Fig. 45.

## Configure the Unit for Thermostat Mode —

Connect to the CCN bus using a CCN service tool and navigate to PremierLink Configuration screen for Operating Mode. Default setting is Sensor Mode (value 1). Change the value to 0 to reconfigure the controller for Thermostat Mode.

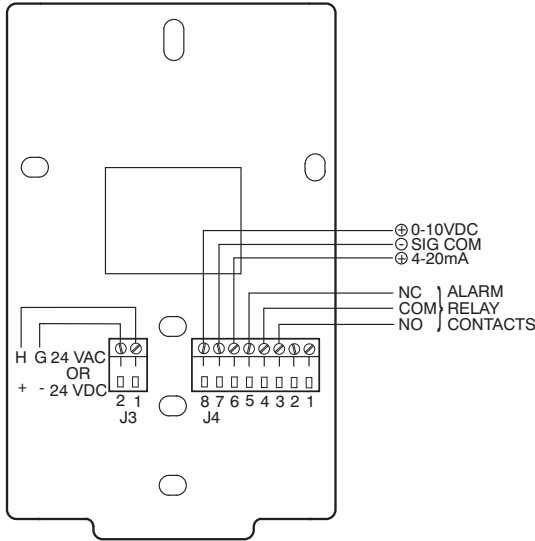
When the PremierLink is configured for Thermostat Mode, these functions are not available: Fire Shutdown (FSD), Remote Occupied (RMTOCC), Compressor Safety (CMPSAFE), Supply Fan Status (SFS), and Filter Pressure Switch (FILTER).

## Economizer Controls

### Indoor Air Quality (CO<sub>2</sub>) Sensor —

The indoor air quality sensor accessory monitors space carbon dioxide (CO<sub>2</sub>) levels. This information is used to monitor IAQ levels. Several types of sensors are available, for wall mounting in the space or in return duct, with and without LCD display, and in combination with space temperature sensors. Sensors use infrared technology to measure the levels of CO<sub>2</sub> present in the space air.

The CO<sub>2</sub> sensors are all factory set for a range of 0 to 2000 ppm and a linear mA output of 4 to 20. Refer to the instructions supplied with the CO<sub>2</sub> sensor for electrical requirements and terminal locations. See Fig. 49 for typical CO<sub>2</sub> sensor wiring schematic.



C08635

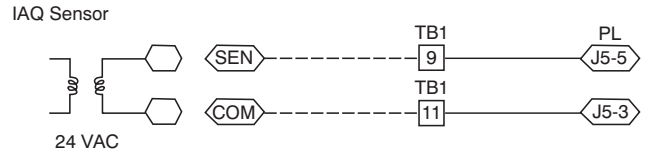
**Fig. 49 - Indoor/Outdoor Air Quality (CO<sub>2</sub>) Sensor (33ZCSENCO2) - Typical Wiring Diagram**

To accurately monitor the quality of the air in the conditioned air space, locate the sensor near a return-air grille (if present) so it senses the concentration of CO<sub>2</sub> leaving the space. The sensor should be mounted in a location to avoid direct breath contact.

Do not mount the IAQ sensor in drafty areas such as near supply ducts, open windows, fans, or over heat sources. Allow at least 3 ft (0.9 m) between the sensor and any corner. Avoid mounting the sensor where it is influenced by the supply air; the sensor gives inaccurate readings if the supply air is blown directly onto the sensor or if the supply air does not have a chance to mix with the room air before it is drawn into the return airstream.

**Wiring the Indoor Air Quality Sensor:** For each sensor, use two 2-conductor 18 AWG (American Wire Gauge) twisted-pair cables (unshielded) to connect the separate isolated 24 vac power source to the sensor and to connect the sensor to the control board terminals.

To connect the sensor to the control, identify the positive (4 to 20 mA) and ground (SIG COM) terminals on the sensor. See Fig. 49. Connect the 4-20 mA terminal to terminal TB1-9 and connect the SIG COM terminal to terminal TB1-11. See Fig. 50.



C08636

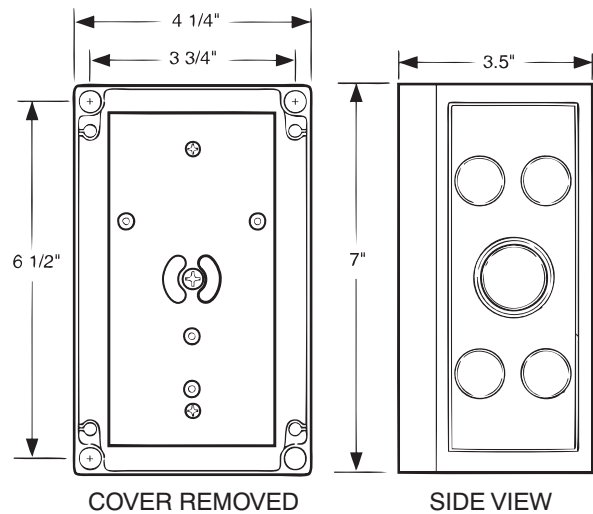
**Fig. 50 - Indoor CO<sub>2</sub> Sensor (33ZCSENCO2) Connections**

Refer to Form 33CS-68SI, PremierLink Installation, Start-up, and Configuration Instructions, for detailed configuration information

### Outdoor Air Quality Sensor

#### (PNO 33ZCSENCO2 plus weatherproof enclosure) —

The outdoor air CO<sub>2</sub> sensor is designed to monitor carbon dioxide (CO<sub>2</sub>) levels in the outside ventilation air and interface with the ventilation damper in an HVAC system. The OAQ sensor is packaged with an outdoor cover. See Fig. 51. The outdoor air CO<sub>2</sub> sensor must be located in the economizer outside air hood.

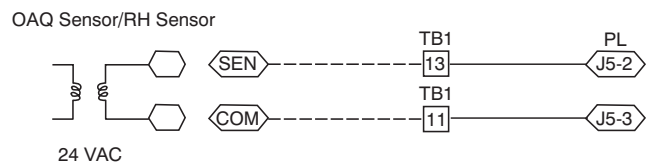


C07135

**Fig. 51 - Outdoor Air Quality Sensor Cover**

**Wiring the Outdoor Air CO<sub>2</sub> Sensor:** A dedicated power supply is required for this sensor. A two-wire cable is required to wire the dedicated power supply for the sensor. The two wires should be connected to the power supply and terminals 1 and 2.

To connect the sensor to the control, identify the positive (4 to 20 mA) and ground (SIG COM) terminals on the OAQ sensor. See Fig. 49. Connect the 4 to 20 mA terminal to the TB1-13 terminal of the 48KC. Connect the SIG COM terminal to the TB1-11 terminal of the 48KC. See Fig. 52.



C08275

**Fig. 52 - Outdoor CO<sub>2</sub> Sensor Connections**

## Space Relative Humidity Sensor or Humidistat Connections —

**NOTE:** The accessory space relative humidity sensor and humidistat are not available for single phase (-3 voltage code) models.

**Space Relative Humidity Sensor connections:** The accessory space relative humidity sensor (33ZCSENSORH-02) is installed on an interior wall to measure the relative humidity of the air within the occupied space.

The use of a standard 2 X 4 inch electrical box to accommodate the wiring is recommended for installation. The sensor can be mounted directly on the wall, if acceptable by local codes.

48KC

### ⚠ CAUTION

#### UNIT DAMAGE HAZARD

Failure to follow this caution may result in permanent damage to the sensor.

DO NOT clean or touch the sensing element with chemical solvents as they can permanently damage the sensor.

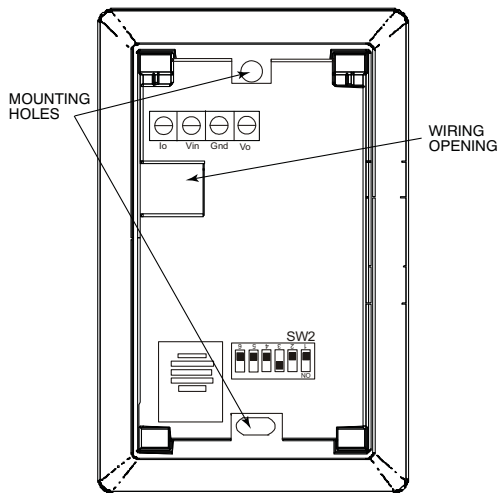
### ⚠ CAUTION

#### UNIT PERFORMANCE HAZARD

Failure to follow this caution will result in inaccurate sensor readings.

DO NOT mount the sensor in drafty areas such as near heating or air-conditioning ducts, open windows, fans, or over heat sources such as baseboard heaters, radiators, or wall-mounted dimmers. Sensors mounted in those areas will produce inaccurate readings.

If the sensor is installed directly on a wall service, install the humidity sensor using 2 screws and 2 hollow wall anchors (field supplied). Do not over tighten screws. See Fig. 53.



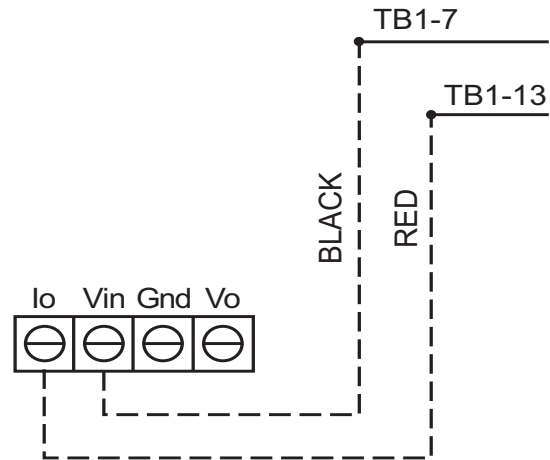
**Fig. 53 - Space Relative Humidity Sensor Installation**

C11084

The sensor must be mounted vertically on the wall. The Carrier logo should be orientated correctly when the sensor is properly mounted.

Avoid corner locations. Allow at least 4 ft between the sensor and any corner. Airflow near corners tends to be reduced, resulting in erratic sensor readings. The sensor should be vertically mounted approximately 5 ft up from the floor, beside the space temperature sensor.

For wiring distances up to 500 feet, use a 3-conductor, 18 or 20 AWG cable. ACCN communication cable can be used, although the shield is not required. The shield must be removed from the sensor end of the cable if this cable is used. See Fig. 54 for wiring details.



C11180

**Fig. 54 - Space Relative Humidity Sensor Connection**

The power for the sensor is provided by the PremierLink control on terminal J5-4 (+33 to +35vdc).

#### To wire the sensor:

1. At the sensor, remove 4 inches from the jacket from the cable. Strip ¼ inch of insulation from each conductor. Route the cable through the wire clearance opening in the center of the sensor. See Fig. 53.
2. Connect a field-supplied BLACK wire to the sensor screw terminal marked Vin.
3. Connect a field-supplied RED wire into the sensor screw terminal marked Io.
4. Connect the field-supplied RED wire from the sensor to TB1-13.
5. Connect the field-supplied BLACK wire from the sensor to TB1-7.

#### Smoke Detector/Fire Shutdown (FSD) —

This function is available only when PremierLink is configured for (Space) Sensor Mode. The unit is factory-wired for PremierLink FSD operation when PremierLink is factory-installed.

On 48KC units equipped with factory-installed Smoke Detector(s), the smoke detector controller implements the unit shutdown through its NC contact set connected to the unit's CTB input. The FSD function is initiated via the smoke detector's Alarm NO contact set. The PremierLink communicates the smoke detector's tripped status to the CCN building control. See Figs. 41 and 42, PremierLink wiring schematics.

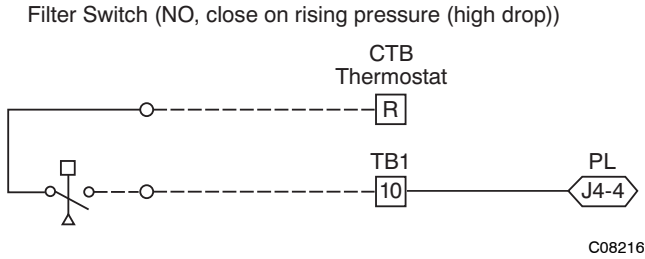


### Filter Status Switch —

This function is available only when PremierLink is configured for (Space) Sensor Mode.

PremierLink control can monitor return filter status in two ways: By monitoring a field-supplied/installed filter pressure switch or via supply fan runtime hours.

Using switch input: Install the dirty filter pressure switch according to switch manufacturer's instructions, to measure pressure drop across the unit's return filters. Connect one side of the switch's NO contact set to CTB's THERMOSTAT-R terminal. Connect the other side of the NO contact set to TB1-10. Setpoint for Dirty Filter is set at the switch. See Fig. 55.



**Fig. 55 - PremierLink Filter Switch Connection**

When the filter switch's NO contact set closes as filter pressure drop increases (indicating dirt-laden filters), the input signal to PremierLink causes the filter status point to read "DIRTY".

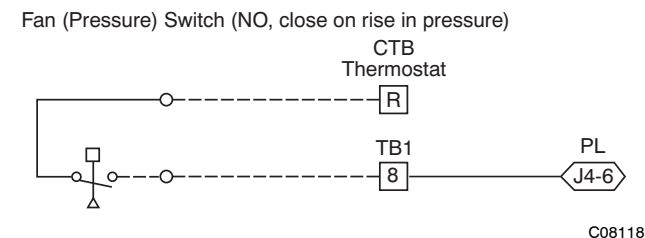
**Using Filter Timer Hours:** Refer to Form 33CS-68SI for instructions on using the PremierLink Configuration screens and on unit alarm sequence.

### Supply Fan Status Switch —

The PremierLink control can monitor supply fan operation through a field-supplied/installed differential pressure switch. This sequence will prevent (or interrupt) operation of unit cooling, heating and economizer functions until the pressure switch contacts are closed indicating proper supply fan operation.

Install the differential pressure switch in the supply fan section according to switch manufacturer's instructions. Arrange the switch contact to be open on no flow and to close as pressure rises indicating fan operation.

Connect one side of the switch's NO contact set to CTB's THERMOSTAT-R terminal. Connect the other side of the NO contact set to TB1-8. Setpoint for Supply Fan Status is set at the switch. See Fig. 56.

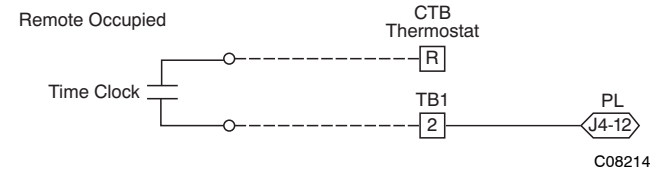


**Fig. 56 - PremierLink Wiring Fan Pressure Switch Connection**

### Remote Occupied Switch —

The PremierLink control permits a remote timeclock to override the control's on-board occupancy schedule and place the unit into Occupied mode. This function may also provide a "Door Switch" time delay function that will terminate cooling and heating functions after a 2-20 minute delay.

Connect one side of the NO contact set on the timeclock to CTB's THERMOSTAT-R terminal. Connect the other side of the timeclock contact to the unit's TB1-2 terminal (see Fig. 57).

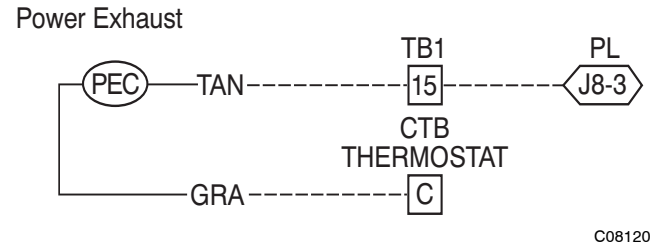


**Fig. 57 - PremierLink Wiring Remote Occupied**

Refer to Form 33CS-68SI for additional information on configuring the PremierLink control for Door Switch timer function.

### Power Exhaust (output) —

Connect the accessory Power Exhaust contactor coils(s) per Fig. 58.



**Fig. 58 - PremierLink Power Exhaust Output Connection**

**NOTE:** The Power Exhaust and Humidi-MiZer<sup>®</sup> options can not be used with PremierLink at the same time as both options require connection at TB1-15 (AUX OUT).

### CCN Communication Bus —

The PremierLink controller connects to the bus in a daisy chain arrangement. Negative pins on each component must be connected to respective negative pins, and likewise, positive pins on each component must be connected to respective positive pins. The controller signal pins must be wired to the signal ground pins. Wiring connections for CCN must be made at the 3-pin plug.

At any baud (9600, 19200, 38400 baud), the number of controllers is limited to 239 devices maximum. Bus length may not exceed 4000 ft, with no more than 60 total devices on any 1000-ft section. Optically isolated RS-485 repeaters are required every 1000 ft.

**NOTE:** Carrier device default is 9600 band.

48KC

**Communications Bus Wire Specifications:** The CCN Communication Bus wiring is field-supplied and field-installed. It consists of shielded 3-conductor cable with drain (ground) wire. The cable selected must be identical to the CCN Communication Bus wire used for the entire network.

See Table 9 for recommended cable.

**Table 9 – Recommended Cables**

MANUFACTURER	CABLE PART NO.
Alpha	2413 or 5463
American	A22503
Belden	8772
Columbia	02525

**NOTE:** Conductors and drain wire must be at least 20 AWG, stranded, and tinned copper. Individual conductors must be insulated with PVC, PVC/nylon, vinyl, Teflon, or polyethylene. An aluminum/polyester 100% foil shield and an outer jacket of PVC, PVC/nylon, chrome vinyl, or Teflon with a minimum operating temperature range of -20°C to 60°C is required. Do not run communication wire in the same conduit as or next to any AC voltage wiring.

The communication bus shields must be tied together at each system element. If the communication bus is entirely within one building, the resulting continuous shield must be connected to ground at only one single point. If the communication bus cable exits from one building and enters another building, the shields must be connected to the grounds at a lightning suppressor in each building (one point only).

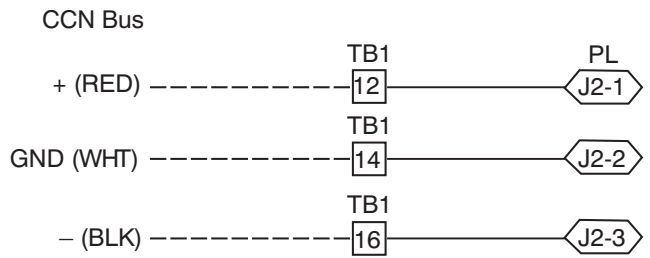
**Connecting CCN bus:**

**NOTE:** When connecting the communication bus cable, a color code system for the entire network is recommended to simplify installation and checkout. See Table 10 for the recommended color code.

**Table 10 – Color Code Recommendations**

SIGNAL TYPE	CCN BUS WIRE COLOR	CCN PLUG PIN NUMBER
+	Red	1
Ground	White	2
-	Black	3

Connect the CCN (+) lead (typically RED) to the unit’s TB1-12 terminal. Connect the CCN (ground) lead (typically WHT) to the unit’s TB1-14 terminal. Connect the CCN (-) lead (typically BLK) to the unit’s TB1-16 terminal. See Fig. 59.



C08276

**Fig. 59 - PremierLink CCN Bus Connections**

## RTU Open Control System

The RTU Open control is factory-mounted in the 48KC unit's main control box, to the left of the CTB. See Fig. 61 (or Fig. 62). Factory wiring is completed through harnesses connected to the CTB. Field connections for RTU Open sensors will be made at the Phoenix connectors on the RTU Open board. The factory-installed RTU Open control includes the supply-air temperature (SAT) sensor. The outdoor air temperature (OAT) sensor is included in the FIOP/accessory EconoMi\$er<sup>®</sup> 2 package.

The RTU Open controller is an integrated component of the Carrier rooftop unit. Its internal application programming provides optimum performance and energy efficiency. RTU Open enables the unit to run in 100% stand-alone control mode, Carrier's i-Vu<sup>®</sup> Open network, or a Third Party Building Automation System (BAS). On-board DIP switches allow you to select your protocol (and baud rate) of choice among the four most popular protocols in use today: BACnet, Modbus, Johnson N2 and LonWorks. (See Fig. 60.)

Refer to Table 11, RTU Open Controller Inputs and Outputs for locations of all connections to the RTU Open board.

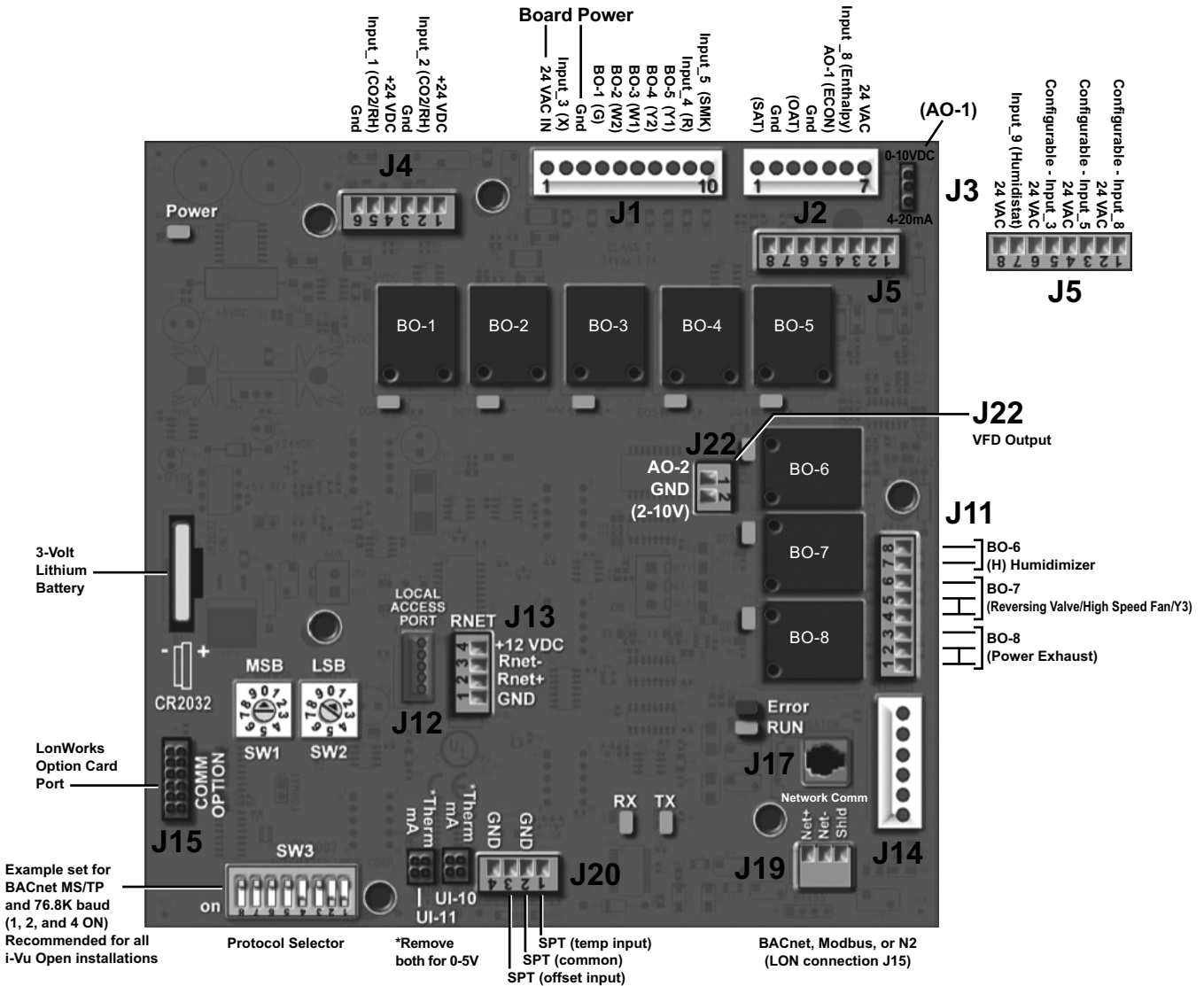


Fig. 60 - RTU Open Multi-Protocol Control Board

C14129

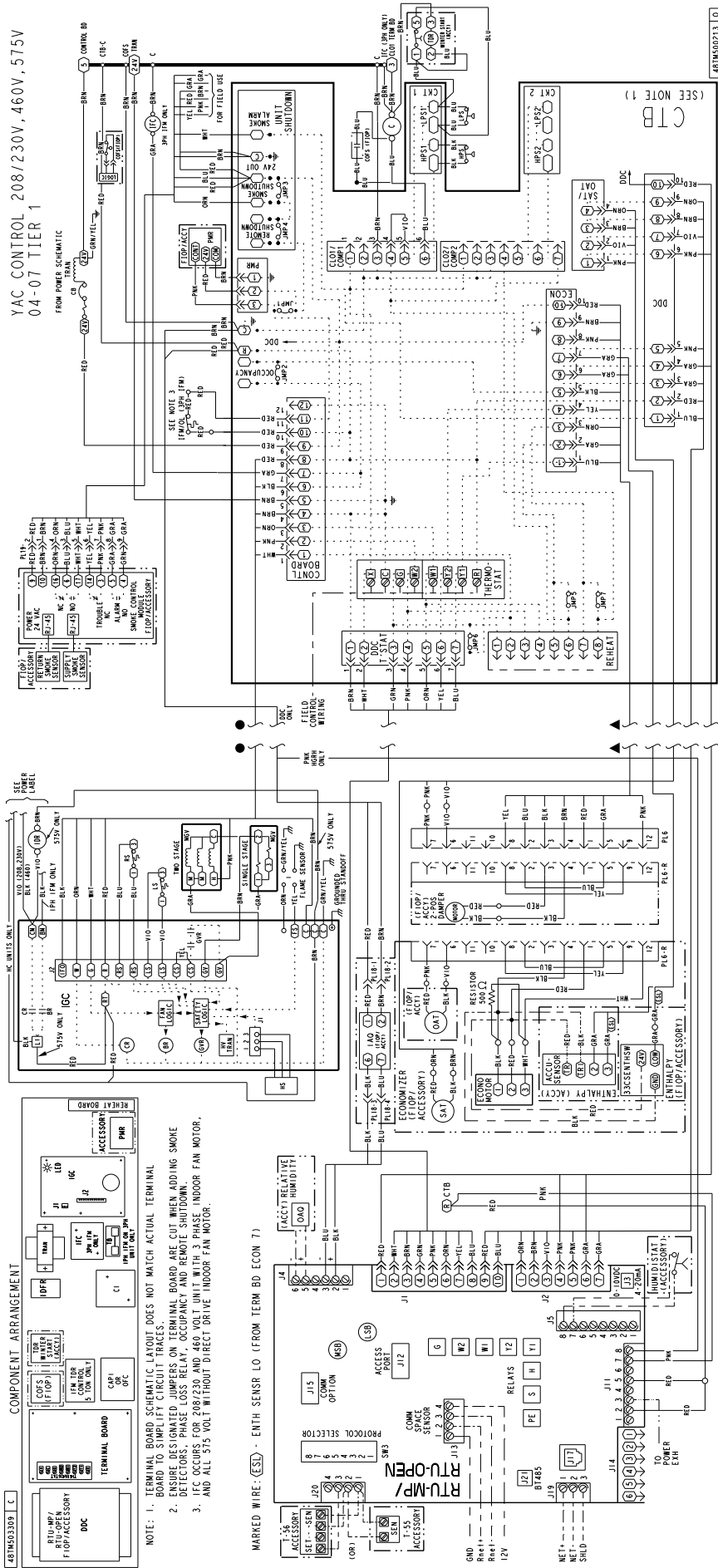


Fig. 61 - RTU Open System Control Wiring Diagram

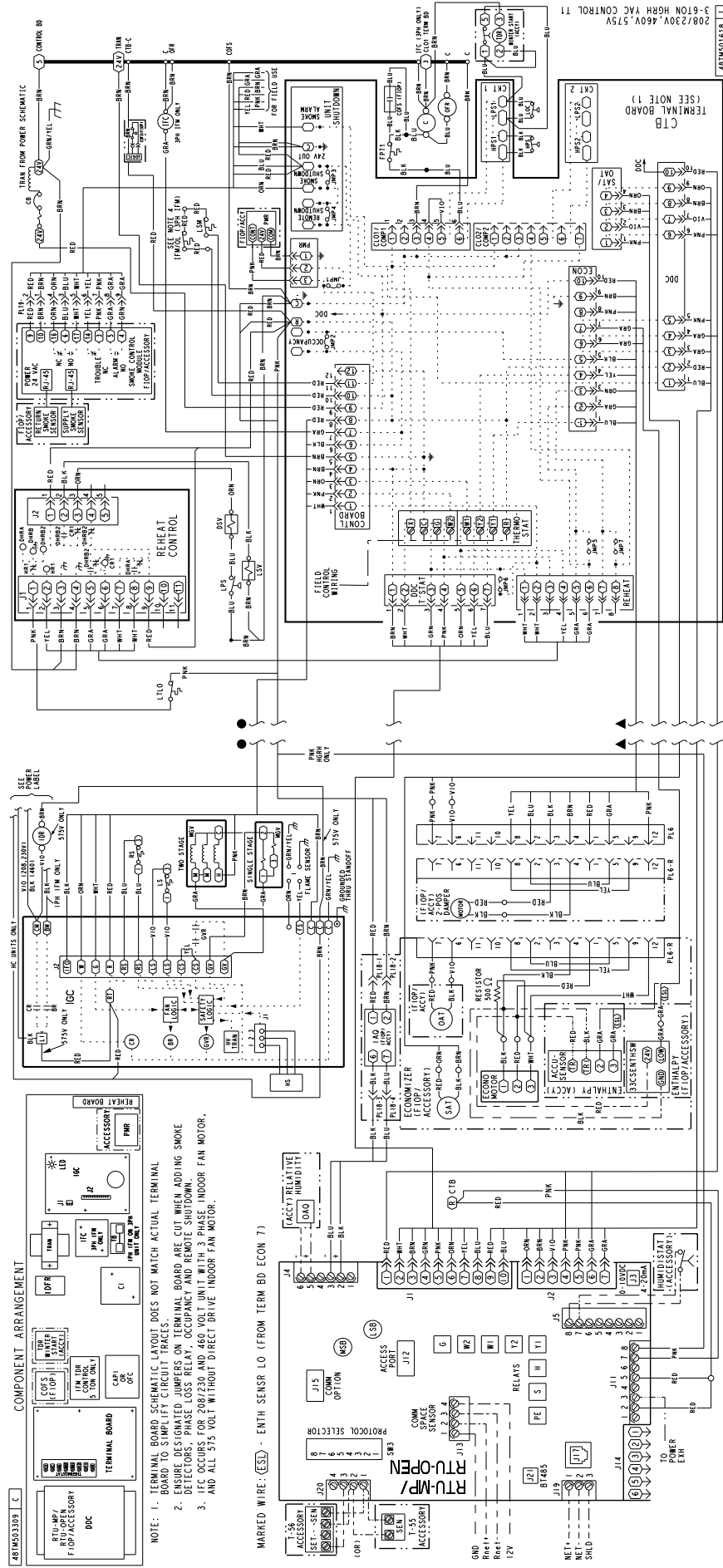


Fig. 62 - RTU Open System Control Wiring Diagram with Humidi-MiZer®

**Table 11 – RTU Open Controller Inputs and Outputs**

POINT NAME	BACnet OBJECT NAME	TYPE OF I/O	CONNECTION PIN NUMBER(S)	CHANNEL DESIGNATION
<b>DEDICATED INPUTS</b>				
Space Temp / Zone Temp	zone_temp	AI (10K Thermistor)	J20-1 & 2	Analog Input 10
Supply Air Temperature	sa_temp	AI (10K Thermistor)	J2-1 & 2	Analog Input 6
Outside Air Temperature	oa_temp	AI (10K Thermistor)	J2-3 & 4	Analog Input 7
Space Temperature Offset Pot	stpt_adj_offset	AI (100K Potentiometer)	J20-3 & 4	Analog Input 11
Safety Chain Feedback	safety_status	BI (24 VAC)	J1-9	Binary Input 4
Compressor Safety Status <sup>(1)</sup>	comp_status	BI (24 VAC)	J1-2	Binary Input 3
Fire Shutdown Status	firedown_status	BI (24 VAC)	J1-10	Binary Input 5
Enthalpy Status	enthalpy_status	BI (24 VAC)	J2-6 & 7	Binary Input 8
Humidistat Input Status	humstat_status	BI (24 VAC)	J5-7 & 8	Binary Input 9
Zone Temperature	n/a	n/a	J13-1-4	Rnet
<b>CONFIGURABLE INPUTS <sup>(4)</sup></b>				
Indoor Air CO2	iaq	AI (4-20 mA)	J4-2 & 3 or J4-5 & 6	Analog Input 2
Outdoor Air CO2	oaq	AI (4-20 mA)		Analog Input 1
Space Relative Humidity	space_rh	AI (4-20 mA)	J5-1 & 2 or J5-3 & 4, J5-5 & 6 or J5-7 & 8 <sup>(3)</sup>	Analog Input 10
Supply Fan Status <sup>(2)</sup>	sfan_status	BI (24 VAC)		Binary Input 3, 5, 8, or 9, except where intrinsic input is used
Filter Status <sup>(2)</sup>	filter_status	BI (24 VAC)		Binary Input 3, 5, 8, or 9, except where intrinsic input is used
Door Contact <sup>(2)</sup>	door_contact_status	BI (24 VAC)		Binary Input 3, 5, 8, or 9, except where intrinsic input is used
Remote Occupancy input <sup>(2)</sup>	occ_contact_status	BI (24 VAC)		Binary Input 3, 5, 8, or 9, except where intrinsic input is used
IGC input <sup>(2)</sup>	igcovr_status	BI (24 VAC)		Binary Input 9. Mandatory input on gas heat units.
<b>OUTPUTS</b>				
Economizer Output	econ_output	AO (4-20mA)	J2-5	Analog Output 1
Supply Fan VFD	vfd_output	AO (2-10Vdc)	J22-1 & 2	Analog Output 2
Supply Fan Relay	sfan	BO Relay (24VAC, 1A)	J1-4	Binary Output 1 (G)
Cool 1 Relay State	comp_1	BO Relay (24VAC, 1A)	J1-8	Binary Output 5 (Y1)
Cool 2 Relay State	comp_2	BO Relay (24VAC, 1A)	J1-7	Binary Output 4 (Y2)
Cool 3 Relay State	comp_3	BO Relay (24VAC, 1A)	J11-5 & 6	Binary Output 7 (Y3)
Heat 1 Relay State	heat_1	BO Relay (24VAC, 1A)	J1-6	Binary Output 3 (W1)
Heat 2 Relay State	heat_2	BO Relay (24VAC, 1A)	J1-5	Binary Output 2 (W2)
Power Exhaust Relay State	pexh	BO Relay (24VAC, 1A)	J11-2 & 3 (N.O.)	Binary Output 8 (PE)
Dehumidification Relay	dehum	BO Relay (24VAC, 1A)	J11-7 & 8 (N.O.)	Binary Output 6

**LEGEND**

- AI – Analog Input
- AO – Analog Output
- BI – Binary Input
- BO – Binary Output

<sup>(1)</sup> Safety Chain Feedback: 24Vac required at this terminal to provide "Run Enable" status. See Input/Output section for additional instructions.

<sup>(2)</sup> These inputs are configurable. If installed, they take the place of the default input on the specific channel. See appropriate Input Configuration Section for wiring and setup instructions.

<sup>(3)</sup> Parallel pins J5-1 = J2-6, J5-3 = J1-10, J5-5 = J1-2 are used for field installation.

<sup>(4)</sup> Refer to the input configuration and accessory sections of the RTU Open Multi-Protocol Controller Controls, Start-Up, Operation and Troubleshooting manual for more detail.

**48KC**

The RTU Open controller requires the use of a Carrier space sensor. A standard thermostat cannot be used with the RTU Open system.

**Supply Air Temperature (SAT) Sensor —**

On FIOP-equipped 48KC unit, the unit is supplied with a supply-air temperature (SAT) sensor (33ZCSENSAT). This sensor is a tubular probe type, approx 6-inches (152 mm) in length. It is a nominal 10-k ohm thermistor.

The SAT is factory-wired. The SAT probe is wire-tied to the supply-air opening (on the horizontal opening end) in its shipping position. Remove the sensor for installation. Re-position the sensor in the flange of the supply-air opening or in the supply air duct (as required by local codes). Drill or punch a 1/2-in. hole in the flange or duct. Use two field-supplied, self-drilling screws to secure the sensor probe in a horizontal orientation. See Fig. 43.

**Outdoor Air Temperature (OAT) Sensor —**

The OAT is factory-mounted in the EconoMiSer<sup>®</sup>2 (FIOP or accessory). It is a nominal 10k ohm thermistor attached to an eyelet mounting ring.

**EconoMiSer2 —**

The RTU Open control is used with EconoMiSer2 (option or accessory) for outdoor air management. The damper position is controlled directly by the RTU Open control; EconoMiSer2 has no internal logic device.

Outdoor air management functions can be enhanced with field-installation of these accessory control devices:

- Enthalpy control (outdoor air or differential sensors)
- Space CO<sub>2</sub> sensor
- Outdoor air CO<sub>2</sub> sensor

## Field Connections

Field connections for accessory sensors and input devices are made the RTU Open, at plugs J1, J2, J4, J5, J11 and J20. All field control wiring that connects to the RTU Open must be routed through the raceway built into the corner post as shown in Fig. 33. The raceway provides the UL required clearance between high- and low-voltage wiring. Pass the control wires through the hole provided in the corner post, then feed the wires thorough the raceway to the RTU Open. Connect to the wires to the removable Phoenix connectors and then reconnect the connectors to the board.

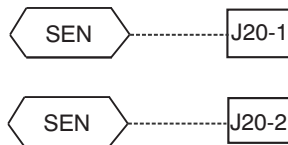
### Space Temperature (SPT) Sensors —

There are two types of SPT sensors available from Carrier, resistive input non-communicating (T55, T56, and T59) and Rnet communicating (SPS, SPPL, SPP, and SPPF) sensors. Each type has a variety of options consisting of: timed override button, set point adjustment, a LCD screen, and communication tie in. Space temperature can be also be written to from a building network or zoning system. However, it is still recommended that return air duct sensor be installed to allow stand-alone operation for back-up. Refer to the configuration section for details on controller configurations associated with space sensors.

- 33ZCT55SPT, space temperature sensor with override button (T-55)
- 33ZCT56SPT, space temperature sensor with override button and setpoint adjustment (T-56)
- 33ZCT59SPT, space temperature sensor with LCD (liquid crystal display) screen, override button, and setpoint adjustment (T-59)

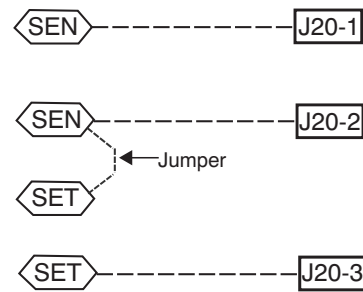
Use 20 gauge wire to connect the sensor to the controller. The wire is suitable for distances of up to 500 ft. Use a three-conductor shielded cable for the sensor and setpoint adjustment connections. If the setpoint adjustment (slidebar) is not required, then an unshielded, 18 or 20 gauge, two-conductor, twisted pair cable may be used.

**Connect T-55:** See Fig. 44 for typical T-55 internal connections. Connect the T-55 SEN terminals to RTU Open J20-1 and J20-2. See Fig. 63.



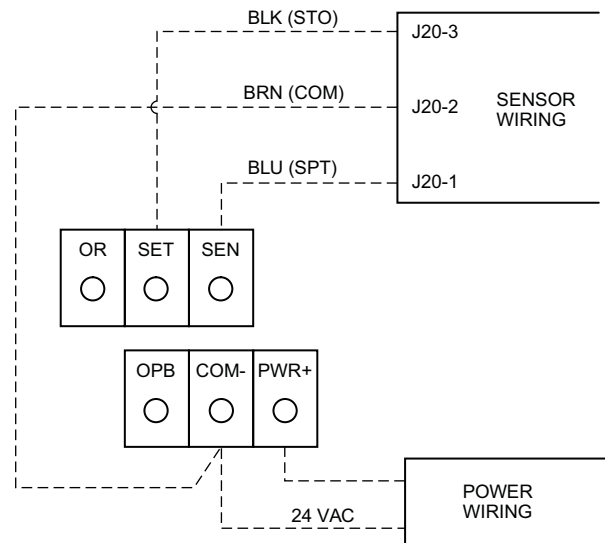
**Fig. 63 - RTU Open T-55 Sensor Connections**

**Connect T-56:** See Fig. 46 for T-56 internal connections. Install a jumper between SEN and SET terminals as illustrated. Connect T-56 terminals to RTU Open J20-1, J20-2 and J20-3 per Fig. 64.



**Fig. 64 - RTU Open T-56 Sensor Connections**

**Connect T-59:** The T-59 space sensor requires a separate, isolated power supply of 24 VAC. See Fig. 65 for internal connections at the T-59. Connect the SEN terminal (BLU) to RTU Open J20-1. Connect the COM terminal (BRN) to J20-2. Connect the SET terminal (STO or BLK) to J20-3.



NOTE: Must use a separate isolated transformer.

**Fig. 65 - Space Temperature Sensor Typical Wiring (33ZCT59SPT)**

### Indoor Air Quality (CO<sub>2</sub>) Sensor —

The indoor air quality sensor accessory monitors space carbon dioxide (CO<sub>2</sub>) levels. This information is used to monitor IAQ levels. Several types of sensors are available, for wall mounting in the space or in return duct, with and without LCD display, and in combination with space temperature sensors. Sensors use infrared technology to measure the levels of CO<sub>2</sub> present in the space air.

The CO<sub>2</sub> sensors are all factory set for a range of 0 to 2000 ppm and a linear mA output of 4 to 20. Refer to the instructions supplied with the CO<sub>2</sub> sensor for electrical requirements and terminal locations. See Fig. 49 for typical CO<sub>2</sub> sensor wiring schematic.

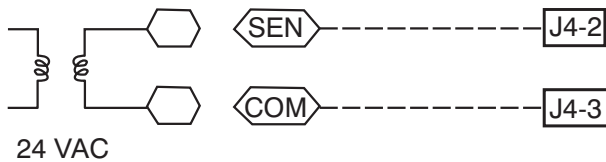
To accurately monitor the quality of the air in the conditioned air space, locate the sensor near a return-air grille (if present) so it senses the concentration of CO<sub>2</sub> leaving the space. The sensor should be mounted in a location to avoid direct breath contact.

Do not mount the IAQ sensor in drafty areas such as near supply ducts, open windows, fans, or over heat sources. Allow at least 3 ft (0.9 m) between the sensor and any corner. Avoid mounting the sensor where it is influenced by the supply air; the sensor gives inaccurate readings if the supply air is blown directly onto the sensor or if the supply air does not have a chance to mix with the room air before it is drawn into the return airstream.

**Wiring the Indoor Air Quality Sensor:** For each sensor, use two 2-conductor 18 AWG (American Wire Gage) twisted-pair cables (unshielded) to connect the separate isolated 24 vac power source to the sensor and to connect the sensor to the control board terminals.

To connect the sensor to the control, identify the positive (4 to 20 mA) and ground (SIG COM) terminals on the sensor. See Fig. 49. Connect the 4-20 mA terminal to RTU Open J4-2 and connect the SIG COM terminal to RTU Open J4-3. See Fig. 66.

IAQ Sensor



C08462

**Fig. 66 - RTU Open / Indoor CO<sub>2</sub> Sensor (33ZCSENCO2) Connections**

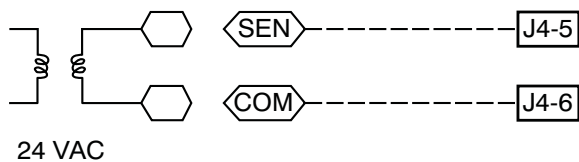
**Outdoor Air Quality Sensor (PNO 33ZCSENCO2 plus weatherproof enclosure) —**

The outdoor air CO<sub>2</sub> sensor is designed to monitor carbon dioxide (CO<sub>2</sub>) levels in the outside ventilation air and interface with the ventilation damper in an HVAC system. The OAQ sensor is packaged with an outdoor cover. See Fig. 51. The outdoor air CO<sub>2</sub> sensor must be located in the economizer outside air hood.

**Wiring the Outdoor Air CO<sub>2</sub> Sensor:** A dedicated power supply is required for this sensor. A two-wire cable is required to wire the dedicated power supply for the sensor. The two wires should be connected to the power supply and terminals 1 and 2.

To connect the sensor to the control, identify the positive (4 to 20 mA) and ground (SIG COM) terminals on the OAQ sensor. See Fig. 49. Connect the 4 to 20 mA terminal to RTU Open J4-5. Connect the SIG COM terminal to RTU Open J4-6. See Fig. 67

OAQ Sensor



C11086

**Fig. 67 - RTU Open / Outdoor CO<sub>2</sub> Sensor (33ZCSENCO2) Connections**

**Space Relative Humidity Sensor or Humidistat —**

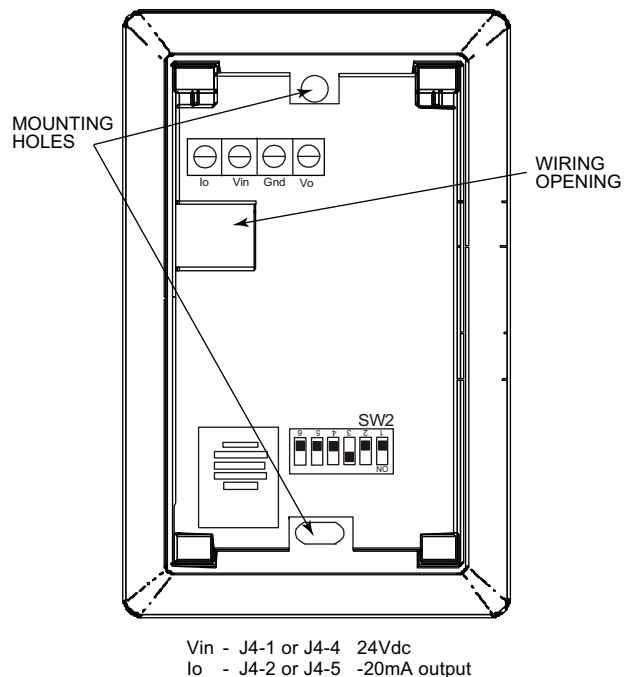
**NOTE:** The accessory space relative humidity sensor and humidistat are not available for single phase (-3 voltage code) models.

**Humidi-MiZer<sup>®</sup> Control Wiring:** In units equipped with the Humidi-MiZer option there are two pink (PNK) wires loose in the control box used to control the dehumidification function of the unit. These pink wires are meant to be tied to a space humidistat or thermidistat on an electromechanical unit. On RTU Open equipped units these pink wires must be connected to J11-7 & 8 to allow the Open board to operate the dehumidification function for the unit. Disconnect the J11 Phoenix style connector from the board and use the plug screws to secure the pink wires in pins 7 and 8, reconnect the plug to the board at J11.

**Relative Humidity Sensors (Space or Duct Mounted):** The accessory space humidity sensor (33ZCSENSRH-02) or duct humidity sensor (33ZCSENDRH-02) is used to measure the relative humidity of air within the space or return air duct. The RH reading is used to control the Humidi-MiZer option of the rooftop unit. For wiring distances up to 500 ft (152 m), use a 3-conductor, 18 or 20 AWG shielded cable. The shield must be removed from the sensor end of the cable and grounded at the unit end. The current loop power for sensor is provided by the RTU Open controller as 24vdc. Refer to the instructions supplied with the RH sensor for the electrical requirements and terminal locations. RTU Open configurations must be changed after adding an RH sensor. See Fig. 68 and 69 for typical RH sensor wiring.

- J4-1 or J4-4 = 24vdc loop power
- J4-2 or J4-5 = 4-20mA signal input

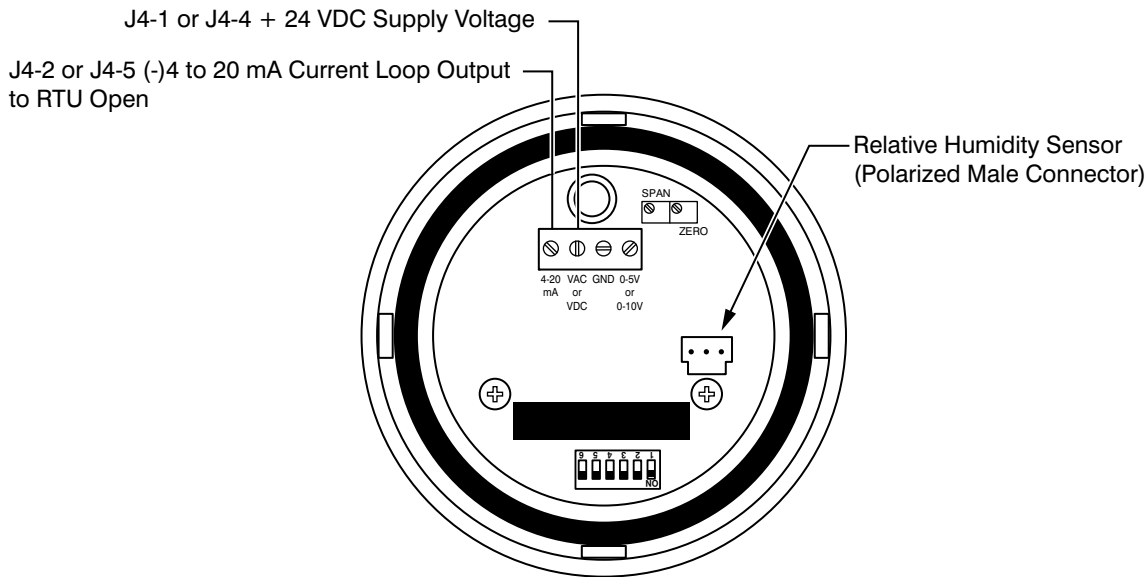
**NOTE:** The factory default for dehumidification control is normally open humidistat.



C11087

**Fig. 68 - Space Relative Humidity Sensor Typical Wiring**





**Fig. 69 - Duct Relative Humidity Sensor Typical Wiring**

C12756

**48KC**

**Humidistat:** The accessory humidistat provides the RTU Open insight to the relative humidity in the space. The humidistat reads the RH level in the space and compares it to its setpoint to operate a dry contact. The humidistat is a dedicated input on the configurable input 9 and tells the RTU Open when the RH level is HIGH or LOW. The normal condition for humidity is LOW. A normally open humidistat is the factory default control for the Humidi-MiZer<sup>®</sup> option.

To wire in the field:

- J5-8 = 24 VAC source for dry contact
- J5-7 = Signal input

**Smoke Detector/Fire Shutdown (FSD) —**

On 48KC units equipped with factory-installed Smoke Detector(s), the smoke detector controller implements the unit shutdown through its NC contact set connected to the unit's CTB input. The FSD function is initiated via the smoke detector's Alarm NO contact set. The RTU Open controller communicates the smoke detector's tripped status to the BAS building control. See Figs. 61 and 62, the RTU Open System Control wiring schematics.

The Fire Shutdown Switch configuration, *MENU* → *Config* → *Inputs* → *input 5*, identifies the normally open status of this input when there is no fire alarm.

**Connecting Discrete Inputs —**

**Filter Status:** The filter status accessory is a field-installed accessory. This accessory detects plugged filters. When installing this accessory, the unit must be configured for filter status by setting *MENU* → *Config* → *Inputs* → *input 3, 5, 8, or 9* to Filter Status and normally open (N/O) or normally closed (N/C). Input 8 or 9 is recommended for easy of installation. Refer to Fig. 60 and Fig. 61 or Fig. 62 for wire terminations at J5.

**Fan Status:** The fan status accessory is a field-installed accessory. This accessory detects when the indoor fan is blowing air. When installing this accessory, the unit must be configured for fan status by setting *MENU* → *Config* → *Inputs* → *input 3, 5, 8, or 9* to Fan Status and normally open (N/O) or normally closed (N/C). Input 8 or 9 is recommended for easy of installation. Refer to Fig. 60 and Figs. 61 or 62 for wire terminations at J5.

**Remote Occupancy:** The remote occupancy accessory is a field-installed accessory. This accessory overrides the unoccupied mode and puts the unit in occupied mode. When installing this accessory, the unit must be configured for remote occupancy by setting *MENU* → *Config* → *Inputs* → *input 3, 5, 8, or 9* to Remote Occupancy and normally open (N/O) or normally closed (N/C).

Also set *MENU* → *Schedules* → *occupancy source* to DI on/off. Input 8 or 9 is recommended for easy of installation. Refer to Fig. 60 and Table 11 for wire terminations at J5.

**Power Exhaust (output):** The relay used by the RTU Open board to control power exhaust is a dry contact which means it does not have 24vac. This 24vac must be connected to the relay to allow it to operate the power exhaust relay in the PE accessory. A 24vac source must be provided to J11-2 on the RTU Open control board. This can be provided by the unit's transformer from various sources. The "R" terminal on the unit's low voltage terminal board (LVTB) is a logical source. Refer to Fig. 60 and Figs. 61 or 62 for wire terminations at J11.

## Communication Wiring - Protocols

### General —

Protocols are the communication languages spoken by control devices. The main purpose of a protocol is to communicate information in the most efficient method possible. Different protocols exist to provide different kinds of information for different applications. In the BAS application, many different protocols are used, depending on manufacturer. Protocols do not change the function of a controller; just make the front end user different.

The RTU Open can be set to communicate on four different protocols: BACnet, Modbus, N2, and LonWorks. Switch 3 (SW3) on the board is used to set protocol and baud rate. Switches 1 and 2 (SW1 and SW2) are used to set the board's network address. See Fig. 70 and 71 for protocol switch settings and address switches. The 3rd party connection to the RTU Open is through plug J19. See Fig. 72 for wiring.

**NOTE:** Power must be cycled after changing the SW1-3 switch settings.

Refer to the *RTU Open v3 Integration Guide* for more detailed information on protocols, 3rd party wiring, and networking.

48KC

SW3 Protocol Selection

PROTOCOL	DS8	DS7	DS6	DS5	DS4	DS3	DS2	DS1
BACnet MS/TP (Master)	Unused	OFF	OFF	OFF	ON	OFF	Select Baud	Select Baud
Modbus (Slave)	Unused	OFF	OFF	ON	ON	OFF	Select Baud	Select Baud
N2 (Slave)	Unused	OFF	OFF	OFF	ON	ON	OFF	OFF
LonWorks	Unused	ON	ON	OFF	ON	OFF	OFF	ON

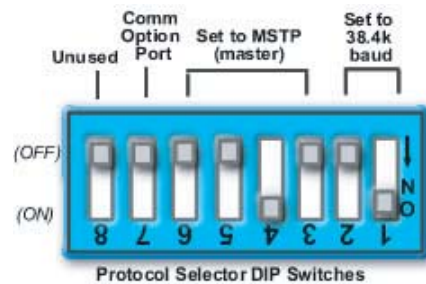
NOTE:

DS = Dip Switch

BACnet MS/TP SW3 example shown

Baud Rate Selections

BAUD RATE	DS2	DS1
9600	OFF	OFF
19,200	ON	OFF
38,400	OFF	ON
76,800	ON	ON



C07166

Fig. 70 - RTU Open SW3 Dip Switch Settings



C10815

Fig. 71 - RTU Open Address Switches

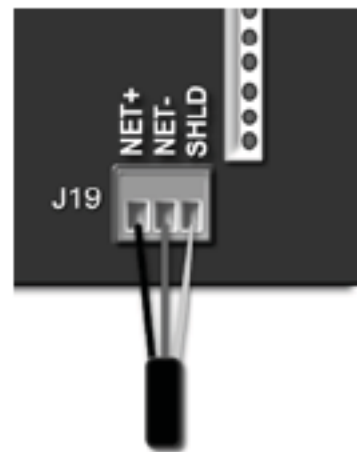


Fig. 72 - Network Wiring

C10816

## Local Access

### Wall Mounted Equipment Touch

The Equipment Touch is a wall mounted interface used to connect to the RTU Open to access the control information, read sensor values, and maintenance. This is an accessory interface that does not come with the RTU Open controller. You wire the Equipment Touch to the RTU Open's J13 local access port. There are 2 password protected levels in the display (User and Admin). See the Equipment Touch Installation and Setup Guide for more information. See Appendix A for navigation and screen content.

### Field Assistant

Field Assistant is a computer program included with the purchase of the Tech Tool Kit (USB-TKIT). This is a field Tech Tool to set-up, service, or download application software to the RTU Open controller and includes a USB Link Cable. The link cable connects a USB port to the J12 local access port. The Field Assistant's menu structure is similar and functions the same as i-Vu<sup>®</sup>. See Fig. 73.

### RTU Open Troubleshooting —

**Communication LEDs** The LEDs indicate if the controller is speaking to the devices on the network. The LEDs should reflect communication traffic based on the baud rate set. The higher the baud rate the more solid the LEDs will appear. See Table 12.

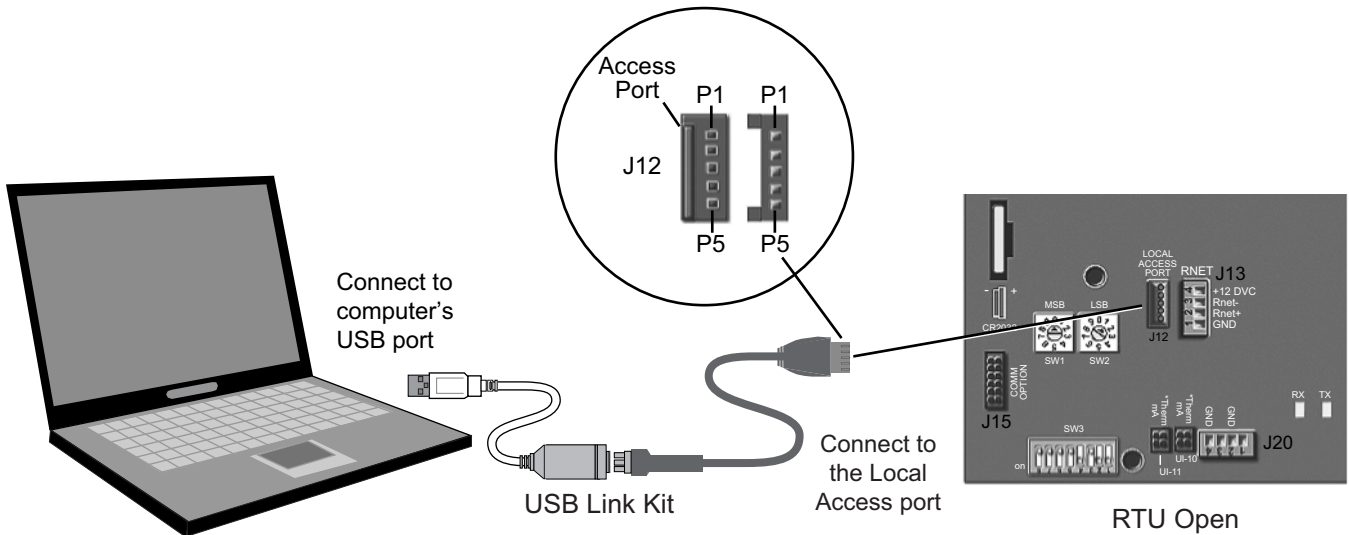


Fig. 73 - PC Running Field Assistant

C14131

**Table 12 – LEDs**  
The LEDs on the RTU Open show the status of certain functions

If this LED is on...	Status is...
<b>Power</b>	The RTU Open has power
<b>Rx</b>	The RTU Open is receiving data from the network segment
<b>Tx</b>	The RTU Open is transmitting data over the network segment
<b>BO#</b>	The binary output is active

The **Run** and **Error** LEDs indicate control module and network status

If Run LED shows...	And Error LED shows...	Status is...
2 flashes per second	Off	Normal
2 flashes per second	2 flashes, alternating with <b>Run</b> LED	Five minute auto–restart delay after system error
2 flashes per second	3 flashes, then off	Control module has just been formatted
2 flashes per second	4 flashes, then pause	Two or more devices on this network have the same MSTP network address
2 flashes per second	On	Exec halted after frequent system errors or control programs halted
5 flashes per second	On	Exec start–up aborted, Boot is running
5 flashes per second	Off	Firmware transfer in progress, Boot is running
7 flashes per second	7 flashes per second, alternating with <b>Run</b> LED	Ten second recovery period after brownout
14 flashes per second	14 flashes per second, alternating with <b>Run</b> LED	Brownout
On	On	Failure. Try the following solutions: <ul style="list-style-type: none"> <li>• Turn the RTU Open off, then on.</li> <li>• Format the RTU Open.</li> <li>• Download memory to the RTU Open.</li> <li>• Replace the RTU Open.</li> </ul>

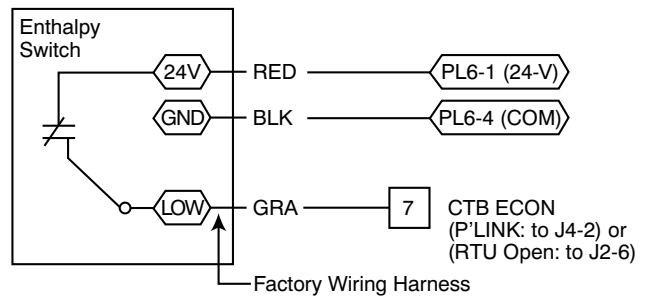
48KC

**NOTE:** Refer to the *RTU Open Multi-Protocol Controller Controls, Start-Up, Operation and Troubleshooting* manual for complete configuration of RTU Open, operating sequences and troubleshooting information. Refer to the *RTU Open v3 Integration Guide* for details on configuration and troubleshooting of connected networks. Have a copy of these manuals available at unit start-up.

**Outdoor Air Enthalpy Control (PNO 33CSENTHSW)**

The enthalpy control (33CSENTHSW) is available as a field-installed accessory to be used with the EconoMiSer<sup>®</sup>2 damper system. The outdoor air enthalpy sensor is part of the enthalpy control. (The separate field-installed accessory return air enthalpy sensor (33CSENTSEN) is required for differential enthalpy control. See Fig. 74.)

Locate the enthalpy control in the economizer next to the Actuator Motor. Locate two GRA leads in the factory harness and connect the gray lead labeled “ESL” to the terminal labeled “LOW”. See Fig. 74. Connect the enthalpy control power input terminals to economizer actuator power leads RED (connect to 24V) and BLK (connect to GND).



C11160  
**Fig. 74 - Enthalpy Switch (33CSENTHSW) Connections**

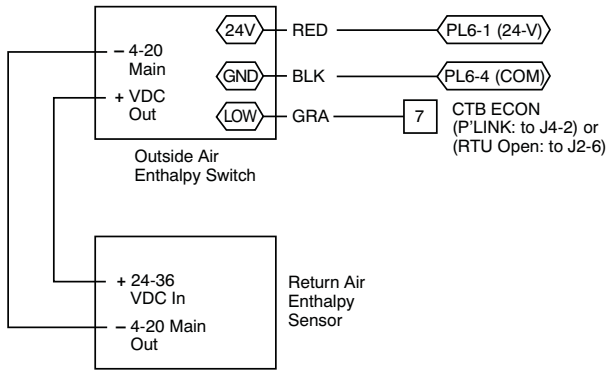
The outdoor enthalpy changeover setpoint is set at the enthalpy controller.

**Differential Enthalpy Control —**

Differential enthalpy control is provided by sensing and comparing the outside air and return air enthalpy conditions. Install the outdoor air enthalpy control as described above. Add and install a return air enthalpy sensor.

## Return Air Enthalpy Sensor —

Mount the return-air enthalpy sensor (33SENTSEN) in the return-air section of the economizer. The return air sensor is wired to the enthalpy controller (33CSENTHSW). See Fig. 75.



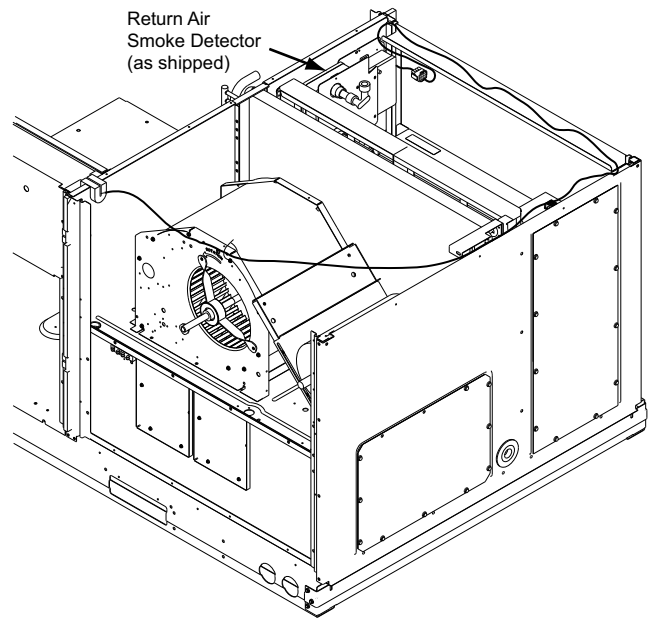
C11161

**Fig. 75 - Outside and Return Air Enthalpy Sensor Wiring**

## Smoke Detectors

Smoke detectors are available as factory-installed options on 48KC models. Smoke detectors may be specified for Supply Air only or for Return Air without or with economizer or in combination of Supply Air and Return Air. All components necessary for operation are factory-provided and mounted. The unit is factory-configured for immediate smoke detector shutdown operation; additional wiring or modifications to unit terminal board may be necessary to complete the unit and smoke detector configuration to meet project requirements.

Units equipped with factory-optional Return Air smoke detectors require a relocation of the sensor module at unit installation. See Fig. 76 for the as shipped location.



C12282

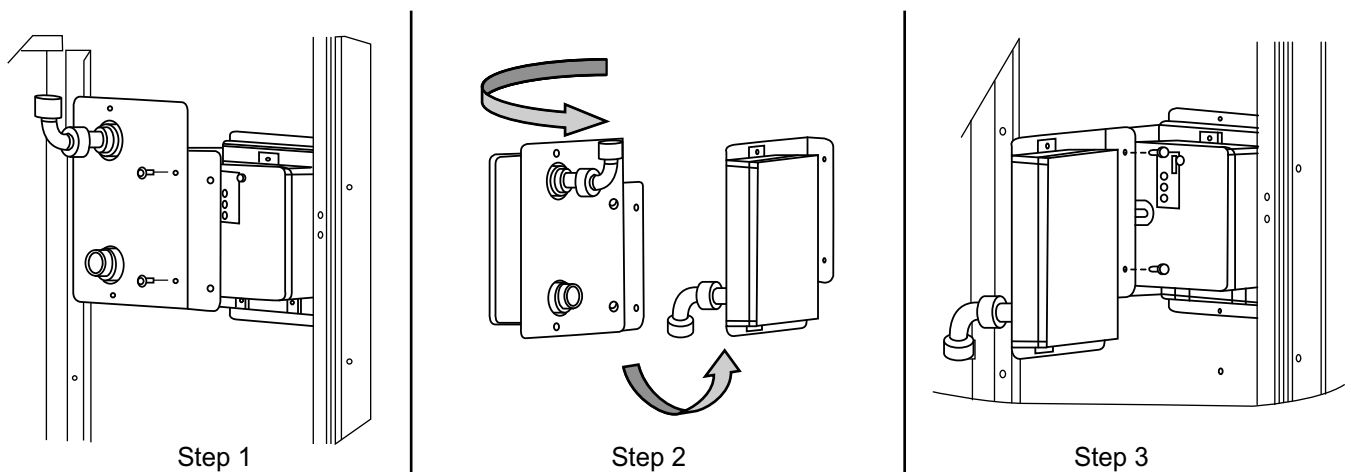
**Fig. 76 - Return Air Smoke Detector, Shipping Position**

## Completing Installation of Return Air Smoke Sensor:

1. Unscrew the two screws holding the Return Air Smoke Detector assembly. See Fig. 77, Step 1. Save the screws.
2. Turn the assembly 90 and then rotate end to end. Make sure that the elbow fitting is pointing down. See Fig. 77, Step 2.
3. Screw the sensor and detector plate into its operating position using screws from Step 1. See Fig. 77, Step 3.
4. Connect the flexible tube on the sampling inlet to the sampling tube on the basepan.

## Additional Application Data —

Refer to Catalog No. HKRNKA-1XA for discussions on additional control features of these smoke detectors including multiple unit coordination.



C12283

**Fig. 77 - Completing Installation of Return Air Smoke Sensor**

**Table 13 – Unit Wire/Fuse or HACR Breaker Sizing Data**

UNIT	NOM. V-Ph-Hz	IFM TYPE	NO C.O. or UNPWR C.O.						w/ PWRD C.O.													
			NO PE.			w/ P.E. (pwrd fr/ unit)			NO PE.			w/ P.E. (pwrd fr/ unit)										
			MCA	MAX FUSE or HACR BRKR	DISC. SIZE FLA LRA	MCA	MAX FUSE or HACR BRKR	DISC. SIZE FLA LRA	MCA	MAX FUSE or HACR BRKR	DISC. SIZE FLA LRA	MCA	MAX FUSE or HACR BRKR	DISC. SIZE FLA LRA								
<b>48KC**04</b>	208/230-1-60	DD-STD	30	45	29	88	32	45	31	90	34	50	34	50	34	93	36	50	36	95		
		MED	27	40	26	93	29	45	28	95	32	45	31	98	45	31	98	34	45	34	100	
		HIGH	29	45	28	118	31	45	30	120	34	50	34	123	50	36	123	36	50	36	125	
	208/230-3-60	DD-STD	22	30	22	82	24	30	24	84	27	30	27	87	30	30	87	29	35	29	89	
		STD	20/19	25/25	19/19	111	22/21	30/30	21/21	113	24/24	30/30	25/24	116	30/30	30/30	116	26/26	30/30	27/26	118	
		MED	20/19	25/25	19/19	111	22/21	30/30	21/21	113	24/24	30/30	25/24	116	30/30	30/30	116	26/26	30/30	27/26	118	
	48KC**04	460-3-60	HIGH	23/23	30/30	23/23	147	25/25	30/30	25/25	149	28/28	30/30	28/28	152	30/30	30/30	152	35/35	30/30	30/30	154
			DD-STD	12	15	12	43	13	15	13	44	14	20	14	45	20	20	14	20	20	16	46
			STD	11	15	10	57	12	15	11	58	13	15	13	59	15	15	13	15	15	14	60
	48KC**05	575-3-60	MED	11	15	10	57	12	15	11	58	13	15	13	59	15	15	13	15	15	14	60
			HIGH	12	15	12	75	13	15	13	76	15	20	15	77	20	20	15	20	20	16	78
			DD-STD	10	15	10	42	12	15	12	44	11	15	12	44	15	15	12	15	15	14	46
208/230-1-60	STD	7	15	7	45	9	15	9	47	9	15	9	47	15	15	9	15	15	11	49		
	MED	7	15	7	45	9	15	9	47	9	15	9	47	15	15	9	15	15	11	49		
	HIGH	9	15	8	60	10	15	10	62	10	15	10	62	15	15	10	15	15	12	64		
208/230-3-60	DD-STD	37	50	35	128	39	50	37	130	41	60	41	133	60	60	41	133	60	43	135		
	MED	34	50	32	133	36	50	35	135	39	60	38	138	60	60	38	138	60	40	140		
	HIGH	34	50	32	158	38	50	37	160	41	60	40	163	60	60	40	163	60	43	165		
48KC**05	460-3-60	DD-STD	26	30	26	94	28	40	28	96	31	40	32	99	40	40	32	99	45	34	101	
		STD	24/24	30/30	23/23	123	26/26	30/30	26/25	125	29/29	40/40	29/29	128	40/40	40/40	29/29	128	40/40	31/31	130	
		MED	24/24	30/30	23/23	123	26/26	30/30	26/25	125	29/29	40/40	29/29	128	40/40	40/40	29/29	128	40/40	31/31	130	
48KC**05	575-3-60	HIGH	27/27	40/40	27/27	159	29/29	40/40	29/29	161	32/32	45/45	33/33	164	45/45	45/45	33/33	164	45/45	35/35	166	
		DD-STD	13	15	13	47	14	20	14	48	15	20	15	49	20	20	15	20	20	16	50	
		STD	12	15	11	61	13	15	12	62	14	15	13	63	15	15	13	63	15	15	64	
48KC**05	575-3-60	MED	12	15	11	61	13	15	12	62	14	15	13	63	15	15	13	63	15	15	64	
		HIGH	13	15	13	79	14	20	14	80	15	20	15	81	20	20	15	20	20	17	82	
		DD-STD	11	15	11	39	13	15	13	41	13	15	13	41	15	15	13	41	15	15	43	
48KC**05	575-3-60	STD	9	15	8	42	11	15	10	44	10	15	10	44	15	15	10	44	15	15	46	
		MED	9	15	8	42	11	15	10	44	10	15	10	44	15	15	10	44	15	15	46	
		HIGH	10	15	9	57	12	15	12	59	12	15	11	59	15	15	11	59	15	15	61	

See "Legend and Notes for Table 13 on page 48.

**Table 13 – Unit Wire/Fuse or HACR Breaker Sizing Data (cont)**

UNIT	NOM. V-Ph-Hz	IFM TYPE	NO C.O. or UNPWR C.O.						w/ PWRD C.O.									
			NO PE.			w/ P.E. (pwrd fr/ unit)			NO PE.			w/ P.E. (pwrd fr/ unit)						
			MCA	MAX FUSE or HACR BRKR	DISC. SIZE FLA LRA	MCA	MAX FUSE or HACR BRKR	DISC. SIZE FLA LRA	MCA	MAX FUSE or HACR BRKR	DISC. SIZE FLA LRA	MCA	MAX FUSE or HACR BRKR	DISC. SIZE FLA LRA				
48KC**06	208/230-1-60	DD-STD	41	60	39	144	42	60	41	146	45	60	44	149	47	60	47	151
		MED	38	60	36	149	40	60	38	151	43	60	42	154	45	60	44	156
		HIGH	40	60	38	174	42	60	41	176	45	60	44	179	47	60	46	181
	208/230-3-60	DD-STD	29	40	28	120	31	45	31	122	34	45	34	125	36	50	36	127
		STD	27/27	40/40	26/26	149	29/29	40/40	28/28	151	32/31	45/45	31/31	154	34/33	45/45	34/33	156
		MED	30/30	45/45	30/29	185	32/32	45/45	32/32	187	35/35	50/50	35/35	190	37/37	50/50	37/37	192
460-3-60	HIGH	30/30	45/45	30/29	185	32/32	45/45	32/32	187	35/35	50/50	35/35	190	37/37	50/50	37/37	192	
	DD-STD	14	20	14	58	15	20	15	59	16	20	16	60	17	20	17	61	
	STD	13	15	12	72	14	20	13	73	15	20	14	74	16	20	16	75	
575-3-60	MED	14	20	14	90	15	20	15	91	17	20	16	92	18	20	18	93	
	HIGH	14	20	14	90	15	20	15	91	17	20	16	92	18	20	18	93	
	DD-STD	12	15	12	46	14	15	14	48	13	15	13	48	15	20	16	50	
48KC**06	575-3-60	STD	9	15	9	49	11	15	11	51	11	15	11	51	13	15	13	53
		MED	11	15	10	64	12	15	12	66	12	15	12	66	14	15	14	68
		HIGH	11	15	10	64	12	15	12	66	12	15	12	66	14	15	14	68

See "Legend and Notes for Table 13 on page 48.



**Legend and Notes for Table 13**

**LEGEND:**

- BRKR – Circuit breaker
- CO – Convenience outlet
- DD – Direct drive (indoor fan motor)
- DISC – Disconnect
- FLA – Full load amps
- IFM – Indoor fan motor
- LRA – Locked rotor amps
- MCA – Minimum circuit amps
- MOCP – MAX FUSE or HACR Breaker
- PE – Power exhaust
- PWRD CO – Powered convenience outlet
- UNPWR CO – Unpowered convenience outlet

**NOTES:**

1. In compliance with NEC requirements for multimotor and combination load equipment (refer to NEC Articles 430 and 440), the overcurrent protective device for the unit shall be fuse or HACR breaker. Canadian units may be fuse or circuit breaker.

**2. Unbalanced 3-Phase Supply Voltage**

Never operate a motor where a phase imbalance in supply voltage is greater than 2%. Use the following formula to determine the percentage of voltage imbalance.

$$\% \text{ Voltage Imbalance} = 100 \times \frac{\text{max voltage deviation from average voltage}}{\text{average voltage}}$$

Example: Supply voltage is 230-3-60



- AB = 224 v
- BC = 231 v
- AC = 226 v

$$\begin{aligned} \text{Average Voltage} &= \frac{(224 + 231 + 226)}{3} = \frac{681}{3} \\ &= 227 \end{aligned}$$

Determine maximum deviation from average voltage.

(AB)  $227 - 224 = 3 \text{ v}$

(BC)  $231 - 227 = 4 \text{ v}$

(AC)  $227 - 226 = 1 \text{ v}$

Maximum deviation is 4 v.

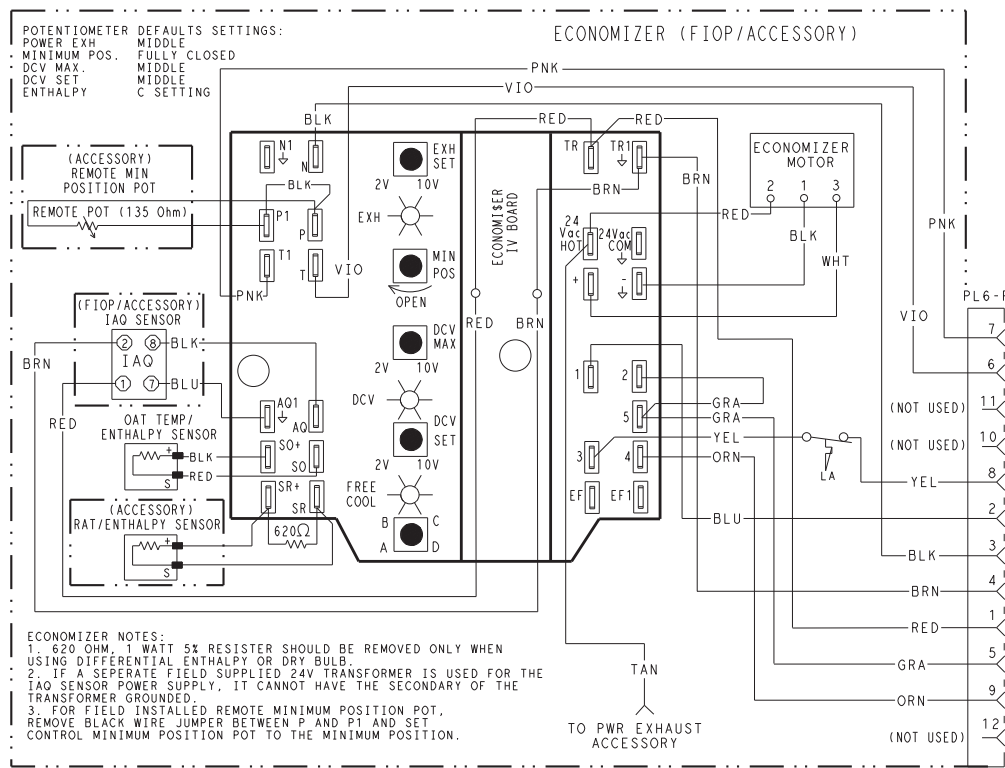
Determine percent of voltage imbalance.

$$\begin{aligned} \% \text{ Voltage Imbalance} &= 100 \times \frac{4}{227} \\ &= 1.76\% \end{aligned}$$

This amount of phase imbalance is satisfactory as it is below the maximum allowable 2%.

**IMPORTANT:** If the supply voltage phase imbalance is more than 2%, contact your local electric utility company immediately.





**Fig. 78 - EconoMiSer® IV Wiring**

C09302

**48KC**

**Step 14 — Adjust Factory-Installed Options**

**Smoke Detectors —**

Smoke detector(s) will be connected at the Controls Connections Board, at terminals marked “Smoke Shutdown”. Cut jumper JMP 3 when ready to energize unit.

**EconoMiSer IV Occupancy Switch —**

Refer to Fig. 78 for general EconoMiSer IV wiring. External occupancy control is managed through a connection on the Controls Connections Board.

If external occupancy control is desired, connect a time clock or remotely controlled switch (closed for Occupied, open for Unoccupied sequence) at terminals marked OCCUPANCY. Cut jumper JMP 2 to complete the installation.

**Step 15 — Install Accessories**

Available accessories include:

- Curb
- Thru-base connection kit (must be installed before unit is set on curb)
- LP conversion kit
- Flue discharge deflector

- Manual outside air damper
- Two-Position motorized outside air damper
- EconoMiSer X (with control)
- EconoMiSer IV (with control)
- EconoMiSer2 (without control/for external signal)
- Power Exhaust
- Differential dry-bulb sensor (EconoMiSer IV)
- Outdoor enthalpy sensor
- Differential enthalpy sensor
- CO<sub>2</sub> sensor
- DDC interface (PremierLink™)
- Louvered hail guard
- Motormaster head pressure controls
- Phase monitor control

Refer to separate installation instructions for information on installing these accessories.

**Pre-Start and Start-Up —**

This completes the mechanical installation of the unit. Refer to the unit’s Service Manual for detailed Pre-Start and Start-Up instructions. Download the latest versions from HVAC Partners ([www.hvacpartners.com](http://www.hvacpartners.com)).



# UNIT START-UP CHECKLIST

(Remove and Store in Job File)

**NOTE: To avoid injury to personnel and damage to equipment or property when completing the procedures listed in this start-up checklist, use good judgement, follow safe practices, and adhere to the safety considerations/information as outlined in the preceding sections of this Installation Instructions document.**

MODEL NO.: \_\_\_\_\_

SERIAL NO.: \_\_\_\_\_

## I. PRE-START-UP

- VERIFY THAT ALL PACKAGING MATERIALS HAVE BEEN REMOVED FROM UNIT
- VERIFY INSTALLATION OF OUTDOOR AIR HOOD
- VERIFY INSTALLATION OF FLUE EXHAUST AND INLET HOOD
- VERIFY THAT CONDENSATE CONNECTION IS INSTALLED PER INSTRUCTIONS
- VERIFY THAT ALL ELECTRICAL CONNECTIONS AND TERMINALS ARE TIGHT
- VERIFY GAS PRESSURE TO UNIT GAS VALVE IS WITHIN SPECIFIED RANGE
- CHECK GAS PIPING FOR LEAKS
- CHECK THAT INDOOR-AIR FILTERS ARE CLEAN AND IN PLACE
- CHECK THAT OUTDOOR AIR INLET SCREENS ARE IN PLACE
- VERIFY THAT UNIT IS LEVEL
- CHECK FAN WHEELS AND PROPELLER FOR LOCATION IN HOUSING/ORIFICE AND VERIFY SETSCREW IS TIGHT
- VERIFY THAT FAN SHEAVES ARE ALIGNED AND BELTS ARE PROPERLY TENSIONED
- VERIFY THAT SCROLL COMPRESSORS ARE ROTATING IN THE CORRECT DIRECTION
- VERIFY INSTALLATION OF THERMOSTAT
- VERIFY THAT CRANKCASE HEATERS HAVE BEEN ENERGIZED FOR AT LEAST 24 HOURS

## II. START-UP

### ELECTRICAL

SUPPLY VOLTAGE	L1-L2 _____	L2-L3 _____	L3-L1 _____
COMPRESSOR AMPS 1	L1 _____	L2 _____	L3 _____
COMPRESSOR AMPS 2	L1 _____	L2 _____	L3 _____
SUPPLY FAN AMPS	L1 _____	L2 _____	L3 _____

### TEMPERATURES

OUTDOOR-AIR TEMPERATURE \_\_\_\_\_ °F DB (DRY BULB)

RETURN-AIR TEMPERATURE \_\_\_\_\_ °F DB \_\_\_\_\_ °F WB (WET BULB)

COOLING SUPPLY AIR TEMPERATURE \_\_\_\_\_ °F

GAS HEAT SUPPLY AIR \_\_\_\_\_ °F

### PRESSURES

GAS INLET PRESSURE \_\_\_\_\_ IN. WG

GAS MANIFOLD PRESSURE STAGE 1 \_\_\_\_\_ IN. WG

STAGE 2 \_\_\_\_\_ IN. WG

REFRIGERANT SUCTION CIRCUIT A \_\_\_\_\_ PSIG

CIRCUIT B \_\_\_\_\_ PSIG

REFRIGERANT DISCHARGE CIRCUIT A \_\_\_\_\_ PSIG

CIRCUIT B \_\_\_\_\_ PSIG

- VERIFY REFRIGERANT CHARGE USING CHARGING CHARTS

## GENERAL

- ECONOMIZER MINIMUM VENT AND CHANGEOVER SETTINGS TO JOB REQUIREMENTS (IF EQUIPPED)
- VERIFY SMOKE DETECTOR UNIT SHUTDOWN BY UTILIZING MAGNET TEST

## III. HUMIDI-MIZER® SYSTEM START-UP

**NOTE:** Units equipped with RTU-Open controls have Service Test menus or modes that can assist with the Humidi-MiZer System Start-Up function and provide the means to make the observations listed for this start-up.

### STEPS

- 1. CHECK CTB FOR JUMPER 5, 6, 7  
JUMPER 5, 6, 7 MUST BE CUT AND OPEN
- 2. OPEN HUMIDISTAT CONTACTS
- 3. START UNIT IN COOLING (CLOSE Y1)

#### OBSERVE AND RECORD

- A. SUCTION PRESSURE \_\_\_\_\_ PSIG
  - B. DISCHARGE PRESSURE \_\_\_\_\_ PSIG
  - C. ENTERING AIR TEMPERATURE \_\_\_\_\_ °F
  - D. LIQUID LINE TEMPERATURE  
AT OUTLET OR REHEAT COIL \_\_\_\_\_ °F
  - E. CONFIRM CORRECT ROTATION FOR COMPRESSOR
  - F. CHECK FOR CORRECT RAMP-UP OF OUTDOOR FAN MOTOR AS CONDENSER COIL WARMS
- 4. CHECK UNIT CHARGE PER CHARGING CHART
  - 5. SWITCH UNIT TO HIGH-LATENT MODE (SUBCOOLER) BY CLOSING HUMIDISTAT WITH Y1 CLOSED

#### OBSERVE

- A. REDUCTION IN SUCTION PRESSURE (5 TO 7 PSI EXPECTED)
  - B. DISCHARGE PRESSURE UNCHANGED
  - C. LIQUID TEMPERATURE DROPS TO 50 TO 55°F RANGE
  - D. LSV SOLENOID ENERGIZED (VALVE CLOSSES)
- 6. SWITCH UNIT TO DEHUMID (REHEAT) BY OPENING Y1

#### OBSERVE

- A. SUCTION PRESSURE INCREASES TO NORMAL COOLING LEVEL
  - B. DISCHARGE PRESSURE DECREASES (35 TO 50 PSI)
  - C. LIQUID TEMPERATURE RETURNS TO NORMAL COOLING LEVEL
  - D. LSV SOLENOID ENERGIZED (VALVE CLOSSES)
  - E. DSV SOLENOID ENERGIZED, VALVE OPENS
- 7. WITH UNIT IN DEHUMID MODE CLOSE W1  
COMPRESSOR AND OUTDOOR FAN STOP; LSV AND DSV SOLENOIDS DE-ENERGIZED
  - 8. OPEN W1 RESTORE UNIT TO DEHUMID MODE
  - 9. OPEN HUMIDISTAT INPUT  
COMPRESSOR AND OUTDOOR FAN STOP; LSV AND DSV SOLENOIDS DE-ENERGIZED
  - 10. RESTORE SETPOINTS FOR THERMOSTAT AND HUMIDISTAT