

48LC

WeatherExpert® Series

Single Package Rooftop

Gas Heat/Electric Cooling Unit

with Puron® (R-410A) Refrigerant

Size: 07



Installation Instructions

NOTE: Read the entire instruction manual before starting the installation.

TABLE OF CONTENTS

SAFETY CONSIDERATIONS	2
Rated Indoor Airflow (cfm)	3
INSTALLATION	7
Jobsite Survey	7
Step 1 - Plan for Unit Location	7
Roof Mount	8
Step 2 - Plan for Sequence of Unit Installation	8
Curb-Mounted Installation	8
Pad-Mounted Installation	8
Frame-Mounted Installation	8
Step 3 - Inspect Unit	8
Step 4 - Provide Unit Support	8
Roof Curb Mount	8
Slab Mount (Horizontal Units Only)	10
Alternate Unit Support (In Lieu of Curb or Slab Mount)	10
Step 5 - Field Fabricate Ductwork	10
Step 6 - Rig and Place Unit	10
Positioning on Curb	11
Step 7 - Convert to Horizontal and Connect Ductwork	11
Step 8 - Install Outside Air Hood	12
Economizer Hood Package Removal and Setup — Factory Option	12
Economizer Hood	12
Step 9 - Install Flue Hood	13
Step 10 - Install Gas Piping	13
Factory-Option Thru-Base Connections (Gas Connections)	14
Step 11 - Install External Condensate Trap and Line ..	16
Step 12 - Make Electrical Connections	17
Field Power Supply	17
Units With Factory-Installed Non-Fused Disconnect or HACR	25
Units Without Factory-Installed Non-Fused Disconnect or HACR	26
All Units	26
Convenience Outlets	26
HACR	28
Factory-Option Thru-Base Connections (Electrical Connections)	28
Units Without Thru-Base Connections	28
Field Control Wiring	28
Thermostat	28
Unit without Thru-Base Connection Kit	29
Heat Anticipator Settings	29
Humidi-MiZer® System Control Connections	29
Humidi-MiZer System - Space RH Controller ..	29
RTU Open Controller (Factory-Installed Option) ...	29
SystemVu™ Controller (Factory-Installed Option) ..	29
Integrated Staging Control (ISC) Board	30
ISC Board — Sequence of Operation	30
General	30
Ventilation	30
Cooling	31
Humidi-MiZer System (Optional)	31
Economizer (Optional)	31
Low Ambient Cooling Operation Down to 40°F (4°C)	32
Heating	32
EconoMiSer® X (Factory-Installed Option)	33
Unit Installation	33
Enthalpy Sensor Relocation	33
W7220 Economizer Controller	33
User Interface	33
Keypad	33
Menu Structure	34
Connections and Applications	39
W7220 Economizer Module Wiring	39
Economizer Control Configurations	40
Enthalpy Changeover Control	40
Enthalpy Settings	40
Demand Controlled Ventilation	42
Economizer Occupancy Control	43
Hardware	44
Actuators	44
Supply Air Temperature Sensor	44
Outside Air Temperature Sensor	44
Enthalpy Control Sensor Configuration	44
Operating Sequences	45
Staged Air Volume (3-Speed) Fan Motor	45

W7220 Economizer Control	45
Base Unit Controls	45
Cooling, Unit With EconoMi\$er® X Without CO ₂ Sensor	45
Heating With EconoMi\$er X	47
Demand Controlled Ventilation	48
Setup and Configuration	48
Initial Menu Display	48
Time-out and Screensaver	48
Checkout	48
Status	49
Calibration of Sensors	49
Resetting All Defaults	49
Troubleshooting	49
Power Up Delay	49
Power Loss (Outage or Brownout)	49
Alarms	49
Clearing Alarms	49
Control Set Point and Configuration Log	52
Staged Air Volume (SAV™) with Variable Frequency Drive	54
Multi-Speed VFD Display Kit (Field-Installed Accessory)	55
Connecting the Keypad to the VFD	56
Program the VFD for 3 Discrete Indoor Fan Speeds .	57
Smoke Detectors	64
Step 13 - Adjust Factory-Installed Options	65
Step 14 - Install Accessories	65
Step 15 - Check Belt Tension	65
UNIT START-UP CHECKLIST	67

SAFETY CONSIDERATIONS

Improper installation, adjustment, alteration, service, maintenance, or use can cause explosion, fire, electrical shock or other conditions which may cause personal injury or property damage. Consult a qualified installer, service agency, or your distributor or branch for information or assistance. The qualified installer or agency must use factory-authorized kits or accessories when modifying this product. Refer to the individual instructions packaged with the kits or accessories when installing.

Follow all safety codes. Wear safety glasses and work gloves. Use quenching cloths for brazing operations and have a fire extinguisher available. Read these instructions thoroughly and follow all warnings or cautions attached to the unit. Consult local building codes and appropriate national electrical codes (in USA, ANSI/NFPA 70, National Electrical Code (NEC); in Canada, CSA C22.1) for special requirements.

It is important to recognize safety information. This is the safety-alert symbol . When you see this symbol on the unit and in instructions or manuals, be alert to the potential for personal injury.

Understand the signal words DANGER, WARNING, CAUTION, and NOTE. These words are used with the

safety-alert symbol. DANGER identifies the most serious hazards which **will** result in severe personal injury or death. WARNING signifies hazards which **could** result in personal injury or death. CAUTION is used to identify unsafe practices, which **may** result in minor personal injury or product and property damage. NOTE is used to highlight suggestions which **will** result in enhanced installation, reliability, or operation.

WARNING

FIRE, EXPLOSION HAZARD

Failure to follow this warning could result in personal injury or death.

Disconnect gas piping from unit when leak testing at pressure greater than 0.5 psig (3450 Pa). Pressures greater than 0.5 psig (3450 Pa) will cause gas valve damage resulting in hazardous condition. If gas valve is subjected to pressure greater than 0.5 psig (3450 Pa), it must be replaced before use. When pressure testing field-supplied gas piping at pressures of 0.5 psig (3450 Pa) or less, a unit connected to such piping must be isolated by closing the manual gas valve.

WARNING

FIRE HAZARD

Failure to follow this warning could result in personal injury, death, and/or property damage.

Inlet pressure tab set screw must be tightened and 1/8 in. NPT pipe plug must be installed to prevent gas leaks.

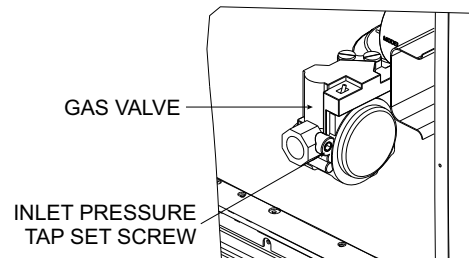

WARNING

FIRE HAZARD

Failure to follow this warning could result in personal injury, death, and/or property damage.

Manifold pressure tap set screw must be tightened and 1/8 in. NPT pipe plug must be installed to prevent gas leak.

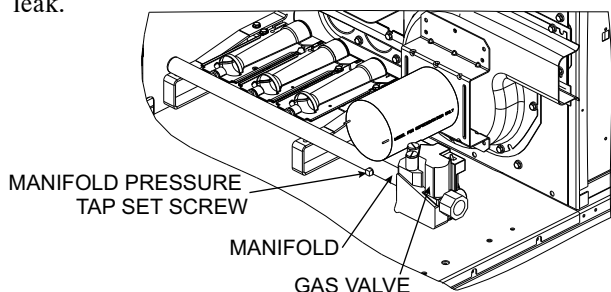

⚠ WARNING

CARBON-MONOXIDE POISONING HAZARD

Failure to follow instructions could result in severe personal injury or death due to carbon-monoxide poisoning, if combustion products infiltrate into the building.

Check that all openings in the outside wall around the vent (and air intake) pipe(s) are sealed to prevent infiltration of combustion products into the building.

Check that furnace vent (and air intake) terminal(s) are not obstructed in any way during all seasons.

⚠ WARNING

ELECTRICAL SHOCK HAZARD

Failure to follow this warning could cause personal injury or death.

Before performing service or maintenance operations on unit, always turn off main power switch to unit and install lock(s) and lockout tag(s). Unit may have more than one power switch.

⚠ WARNING

UNIT OPERATION AND SAFETY HAZARD

Failure to follow this warning could cause personal injury, death and/or equipment damage.

Puron® (R-410A) refrigerant systems operate at higher pressures than standard R-22 systems. Do not use R-22 service equipment or components on Puron refrigerant equipment.

⚠ WARNING

PERSONAL INJURY AND ENVIRONMENTAL HAZARD

Failure to follow this warning could cause personal injury or death.

Relieve pressure and recover all refrigerant before system repair or final unit disposal.

Wear safety glasses and gloves when handling refrigerants. Keep torches and other ignition sources away from refrigerants and oils.

⚠ CAUTION

CUT HAZARD

Failure to follow this caution may result in personal injury.

Sheet metal parts may have sharp edges or burrs. Use care and wear appropriate protective clothing, safety glasses and gloves when handling parts and servicing air-conditioning equipment.

Rated Indoor Airflow (cfm)

This table lists the rated indoor airflow used for the AHRI efficiency rating for the units covered in this document.

Model Number	Full Load Airflow (cfm)
48LC**07	2250

Position:	1	2	3	4	5	6	7	8	9	10	11	12	13	14	15	16	17	18
Example:	4	8	L	C	D	0	0	7	A	1	A	5	-	0	A	0	A	0

Unit Heat Type
48 - Gas Heat Packaged Rooftop

Model Series - WeatherExpert®
LC - Ultra High Efficiency

Heat Options
D = Low Gas Heat
E = Medium Gas Heat
F = High Gas Heat
S = Low Heat w/ Stainless Steel Exchanger
R = Medium Heat w/ Stainless Steel Exchanger
T = High Heat w/ Stainless Steel Exchanger

Refrig. Systems Options
0 = Three stage cooling capacity control with TXV
A = Three stage cooling capacity control with TXV and Humidi-MiZer® System

Cooling Tons
07 - 6 ton

Sensor Options
A = None
B = RA Smoke Detector
C = SA Smoke Detector
D = RA + SA Smoke Detector
E = CO₂
F = RA Smoke Detector and CO₂
G = SA Smoke Detector and CO₂
H = RA + SA Smoke Detector and CO₂

Indoor Fan Options
1 = Standard Static Belt Drive with VFD controller
2 = Medium Static Belt Drive with VFD controller
3 = High Static Belt Drive with VFD controller

Coil Options: Fin/Tube (Condenser- Evaporator - Hail Guard)
A = Al/Cu - Al/Cu
B = Precoat Al/Cu - Al/Cu
C = E-coat Al/Cu - Al/Cu
D = E-coat Al/Cu - E-coat Al/Cu
E = Cu/Cu - Al/Cu
F = Cu/Cu - Cu/Cu
M = Al/Cu -Al/Cu — Louvered Hail Guard
N = Precoat Al/Cu - Al/Cu — Louvered Hail Guard
P = E-coat Al/Cu - Al/Cu — Louvered Hail Guard
Q = E-coat Al/Cu - E-coat Al/Cu — Louvered Hail Guard
R = Cu/Cu - Al/Cu — Louvered Hail Guard
S = Cu/Cu - Cu/Cu — Louvered Hail Guard

Packaging
0 = Standard
1 = LTL

Electrical Options
A = None
B = HACR Circuit Breaker
C = Non-Fused Disconnect
D = Thru-The-Base Connections
E = HACR Circuit Breaker and Thru-The Base Connections
F = Non-Fused Disconnect and Thru-The-Base Connections

Service Options
0 = None
1 = Unpowered Convenience Outlet
2 = Powered Convenience Outlet
3 = Hinged Panels
4 = Hinged Panels and Unpowered Convenience Outlet
5 = Hinged Panels and Powered Convenience Outlet

Intake / Exhaust Options
A = None
B = Standard Leak Temperature Economizer with Barometric Relief
E = Standard Leak Enthalpy Economizer with Barometric Relief
N = Ultra Low Leak Temperature Economizer with Barometric Relief
R = Ultra Low Leak Enthalpy Economizer with Barometric Relief

Base Unit Controls
0 = Electro-mechanical Controls
1 = RTU Open Multi-Protocol Controller
4 = SystemVu™ Controller

Design Revision
- = Factory Design Revision

Voltage
1 = 575/3/60
5 = 208-230/3/60
6 = 460/3/60

Fig. 1 - 48LC 07 Model Number Nomenclature (Example)

a48-9318

UNIT: 48LC 07
 OUTDOOR COIL TYPE: RTPF
 DIMENSIONS: 49-3/8 (1253), 36-3/8 (925), 15-7/8 (403)

NOTES:
 1. DIMENSIONS ARE IN INCHES. DIMENSIONS IN () ARE IN MILLIMETERS.
 2. CENTER OF GRAVITY
 3. DIRECTION OF AIR FLOW

UNITED TECHNOLOGIES STRACUSE, NY CORPORATION'S WRITTEN CONSENT.
 P.O. BOX 4808
 13221

THIS DOCUMENT IS THE PROPERTY OF CARRIER CORPORATION AND IS BELIEVED UPON THE EXPRESS CONDITION THAT THE USER WILL NOT REPRODUCE OR USE WITHOUT CARRIER CORPORATION'S WRITTEN CONSENT.

COMMISSION OF THESE DRAWINGS OR DOCUMENTS DOES NOT CONSTITUTE PART PERFORMANCE OR ACCEPTANCE OF CONTRACT.

CONNECTION SIZES	
A	1 3/8" (351) DIA FIELD POWER SUPPLY KNOCKOUT
B	2 1/2" (641) DIA POWER SUPPLY KNOCKOUT
C	1 3/4" (511) DIA GAUGE ACCESS PLUG
D	7/8" (223) DIA. FIELD CONTROL WIRING HOLE
E	3/4" - 14 NPT CONDENSATE DRAIN
F	3/4" - 14 NPT GAS CONNECTION
G	2" (511) DIA. POWER SUPPLY KNOCK-OUT

THRU-THE-BASE CHART (FIELD INST.)					
THESE HOLES REQUIRED FOR USE WITH ACCY KITS: CROBHPRO02A01: GAS THRU CURB CROBHPRO04A01: GAS THRU BASEPAN					
W	X	Y	Z	WIRE CONDUIT SIZE	REQ'D HOLE USE SIZES (MAX.)
1/2"	1/2"	1/2"	1/2"	7/8"	(22.2)
1 1/4"	(002.004)	POWER	1 3/4"	(44.4)	
(004)	3/4" FPT	GAS	1 3/4"	(44.4)	
* (002) PROVIDES 3/4" FPT THRU CURB FLANGE & FITTING. HOLE SIZE: 2" (50.8)					

THRU-THE-BASE CHART (FIELD INST.)
 TOP "THRU-THE-BASE" FACTORY OPTION FITTINGS FOR ONLY X, Y, & Z ARE PROVIDED. ** FOR BELOW LISTED MODELS, A FIELD SUPPLIED 1/2" ADAPTER IS REQUIRED BETWEEN BASE PAN FITTING AND GAS VALVE:
 **

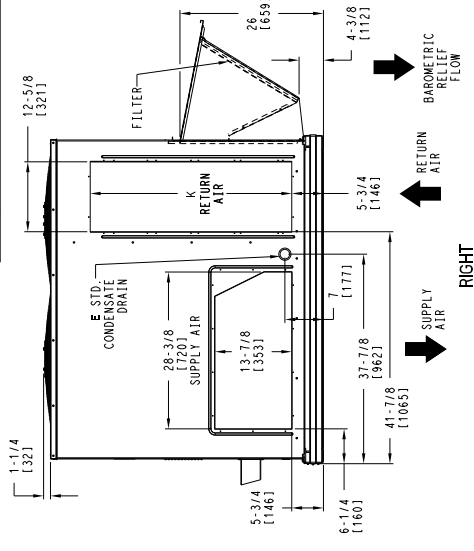
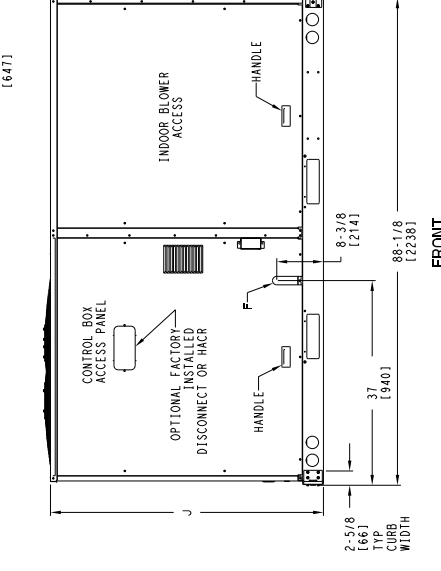
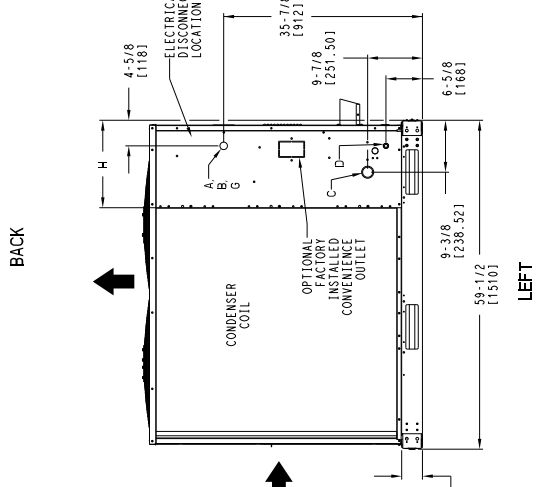
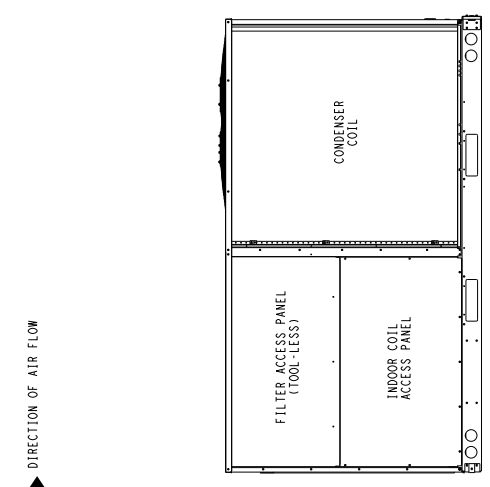
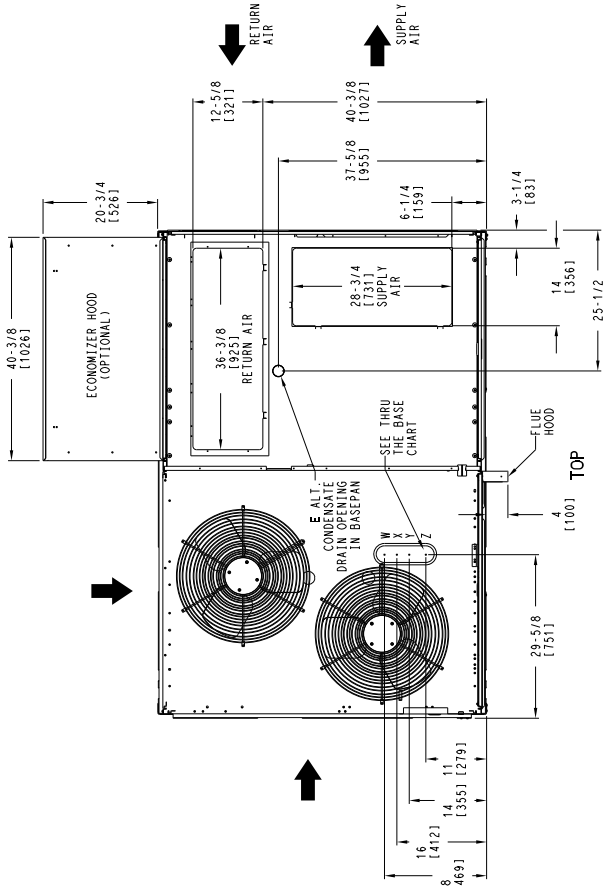

SHEET	DATE	SUPERSEDES	REV
1 OF 2	7/11/14	48LC 07 SINGLE ZONE ELECTRICAL COOLING WITH GAS HEAT	B
	5/8/13	48LC500391	

Fig. 2 - Unit Dimensional Drawing

UNITED TECHNOLOGIES STRAKEUSE, NY
CARRIER

P.O. BOX 4808
13221

THIS DOCUMENT IS THE PROPERTY OF CARRIER CORPORATION AND IS BELIEVED UPON THE EXPRESS CONDITION THAT THE USER WILL NOT REPRODUCE OR USE WITHOUT CARRIER CORPORATION'S WRITTEN CONSENT.

SUBMISSION OF THESE PRINTINGS OR DOCUMENTS DOES NOT CONSTITUTE PART PERFORMANCE OR ACCEPTANCE OF CONTRACT.

UNIT	OUTDOOR COIL TYPE	STD. UNIT WEIGHT ***		CORNER WEIGHT (A)		CORNER WEIGHT (B)		CORNER WEIGHT (C)		CORNER WEIGHT (D)		C.G.								
		LBS.	KG.	LBS.	KG.	LBS.	KG.	LBS.	KG.	LBS.	KG.	X	Y	Z						
48LC 07	RTPF	1032	468	226	102	204	92	286	130	317	144	41	3/4	1060	24	3/4	629	20	3/4	1527

*** STANDARD UNIT WEIGHT IS WITH LOW GAS HEAT AND WITHOUT PACKAGING. FOR OTHER OPTIONS AND ACCESSORIES, REFER TO THE PRODUCT DATA CATALOG.

CORNER B

CORNER A

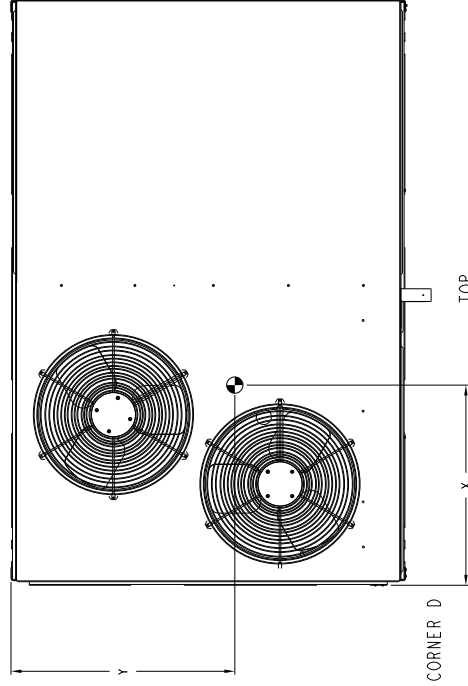

CORNER C

CORNER D

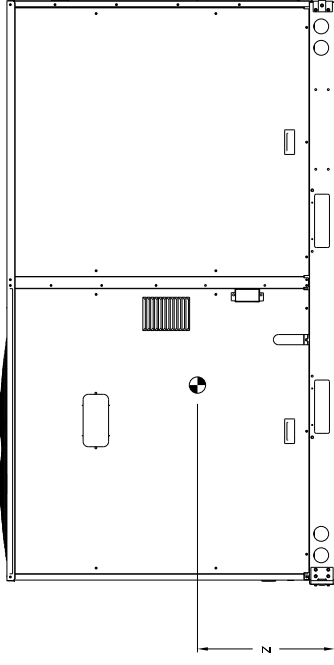

FRONT

SHEET	DATE	SUPERCHGDS	REV
2 OF 2	7/11/14	5/8/13	B

48LC 07 SINGLE ZONE ELECTRICAL COOLING WITH GAS HEAT 48LC500391

Fig. 2 - Unit Dimensional Drawing (cont)

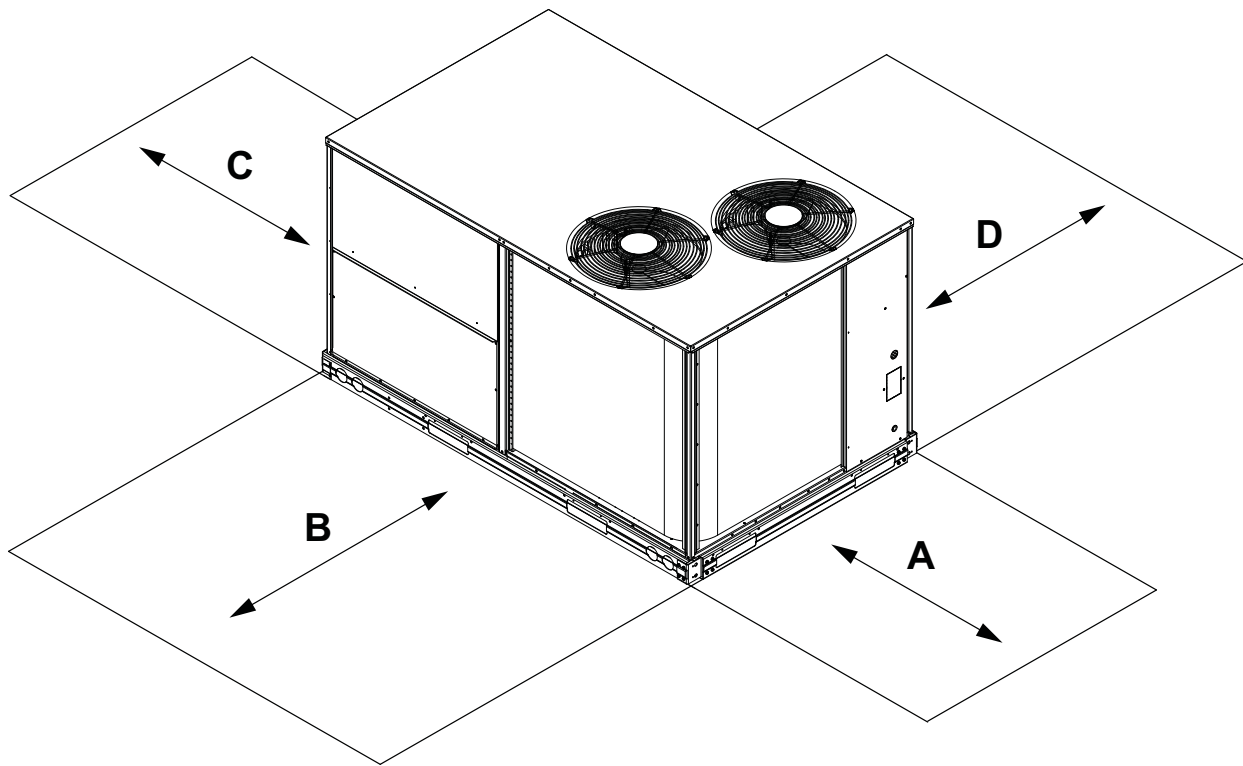

C13093

LOCATION	DIMENSION	CONDITION
A	48-in (1219 mm) 18-in (457 mm) 18-in (457 mm) 12-in (305 mm)	Unit disconnect is mounted on panel No disconnect, convenience outlet option Recommended service clearance Minimum clearance
B	42-in (1067 mm) 36-in (914 mm) Special	Surface behind servicer is grounded (e.g., metal, masonry wall) Surface behind servicer is electrically non-conductive (e.g., wood, fiberglass) Check sources of flue products within 10-ft of unit fresh air intake hood
C	36-in (914 mm) 18-in (457 mm)	Side condensate drain is used Minimum clearance
D	48-in (1219 mm) 42-in (1067 mm) 36-in (914 mm) Special	No flue discharge accessory installed, surface is combustible material Surface behind servicer is grounded (e.g., metal, masonry wall, another unit) Surface behind servicer is electrically non-conductive (e.g., wood, fiberglass) Check for adjacent units or building fresh air intakes within 10-ft (3 m) of this unit's flue outlet

NOTE: Unit not designed to have overhead obstruction. Contact Application Engineering for guidance on any application planning overhead obstruction or for vertical clearances.

Fig. 3 - Service Clearance Dimensional Drawing

INSTALLATION

Jobsite Survey

Complete the following checks before installation.

1. Consult local building codes and the NEC (National Electrical Code) ANSI/NFPA 70 for special installation requirements.
2. Determine unit location (from project plans) or select unit location.
3. Check for possible overhead obstructions which may interfere with unit lifting or rigging.

Step 1 — Plan for Unit Location

Select a location for the unit and its support system (curb or other) that provides for the minimum clearances required for safety. This includes the clearance to combustible surfaces,

unit performance and service access below and around unit as specified in Fig. 3.

NOTE: Consider also the effect of adjacent units.

Be sure that unit is installed such that snow will not block the combustion intake or flue outlet.

Unit may be installed directly on wood flooring or on Class A, B, or C roof-covering material when roof curb is used.

Do not install unit in an indoor location. Do not locate air inlets near exhaust vents or other sources of contaminated air. For proper unit operation, adequate combustion and ventilation air must be provided in accordance with Section 5.3 (Air for Combustion and Ventilation) of the National Fuel Gas Code, ANSI Z223.1 (American National Standards Institute) and NFPA (National Fire Protection Association) 54 TIA--54--84--1. In Canada, installation must be in accordance with the CAN1--B149 installation codes for gas burning appliances.

Although unit is weatherproof, avoid locations that permit water from higher level runoff and overhangs to fall onto the unit.

Locate mechanical draft system flue assembly at least 4 ft (1.2 m) from any opening through which combustion products could enter the building, and at least 4 ft (1.2 m) from any adjacent building (or per local code). Locate the flue assembly at least 10 ft (3.05 m) from an adjacent unit's fresh air intake hood if within 3 ft (0.91 m) of same elevation (or per local code). When unit is located adjacent to public walkways, flue assembly must be at least 7 ft (2.1 m) above grade.

Select a unit mounting system that provides adequate height to allow installation of condensate trap per requirements. Refer to Step 11 — Install External Condensate Trap and Line for required trap dimensions.

Roof Mount —

Check building codes for weight distribution requirements. Unit operating weight is shown in Table 1.

Table 1 – Operating Weights

48LC**07	UNITS LB (KG)
Base Unit	1032 (468)
Economizer	
Vertical	75 (34)
Horizontal	122 (55)
Powered Outlet	35 (16)
Curb	
14-in/356 mm	143 (65)
24-in/610 mm	245 (111)

Step 2 — Plan for Sequence of Unit Installation

The support method used for this unit will dictate different sequences for the steps of unit installation. For example, on curb-mounted units, some accessories must be installed on the unit before the unit is placed on the curb. Review the following for recommended sequences for installation steps.

Curb-mounted Installation —

- Install curb
- Install field-fabricated ductwork inside curb
- Install accessory thru-base service connection package (affects curb and unit) (refer to accessory installation instructions for details)
- Prepare bottom condensate drain connection to suit planned condensate line routing (refer to Step 11 for details)

- Rig and place unit
- Install outdoor air hood
- Install flue hood
- Install gas piping
- Install condensate line trap and piping
- Make electrical connections
- Install other accessories

Pad-mounted Installation —

- Prepare pad and unit supports
- Check and tighten the bottom condensate drain connection plug
- Rig and place unit
- Convert unit to side duct connection arrangement
- Install field-fabricated ductwork at unit duct openings
- Install outdoor air hood
- Install flue hood
- Install gas piping
- Install condensate line trap and piping
- Make electrical connections
- Install other accessories

Frame-mounted Installation —

Frame-mounted applications generally follow the sequence for a curb installation. Adapt as required to suit specific installation plan.

Step 3 — Inspect Unit

Inspect unit for transportation damage. File any claim with transportation agency.

Confirm before installation of unit that voltage, amperage and circuit protection requirements listed on unit data plate agree with power supply provided.

Step 4 — Provide Unit Support

Roof Curb Mount —

Accessory roof curb details and dimensions are shown in Fig. 4. Assemble and install accessory roof curb in accordance with instructions shipped with the curb.

NOTE: The gasketing of the unit to the roof curb is critical for a watertight seal. Install gasket supplied with the roof curb as shown in Fig. 4. Improperly applied gasket can also result in air leaks and poor unit performance.

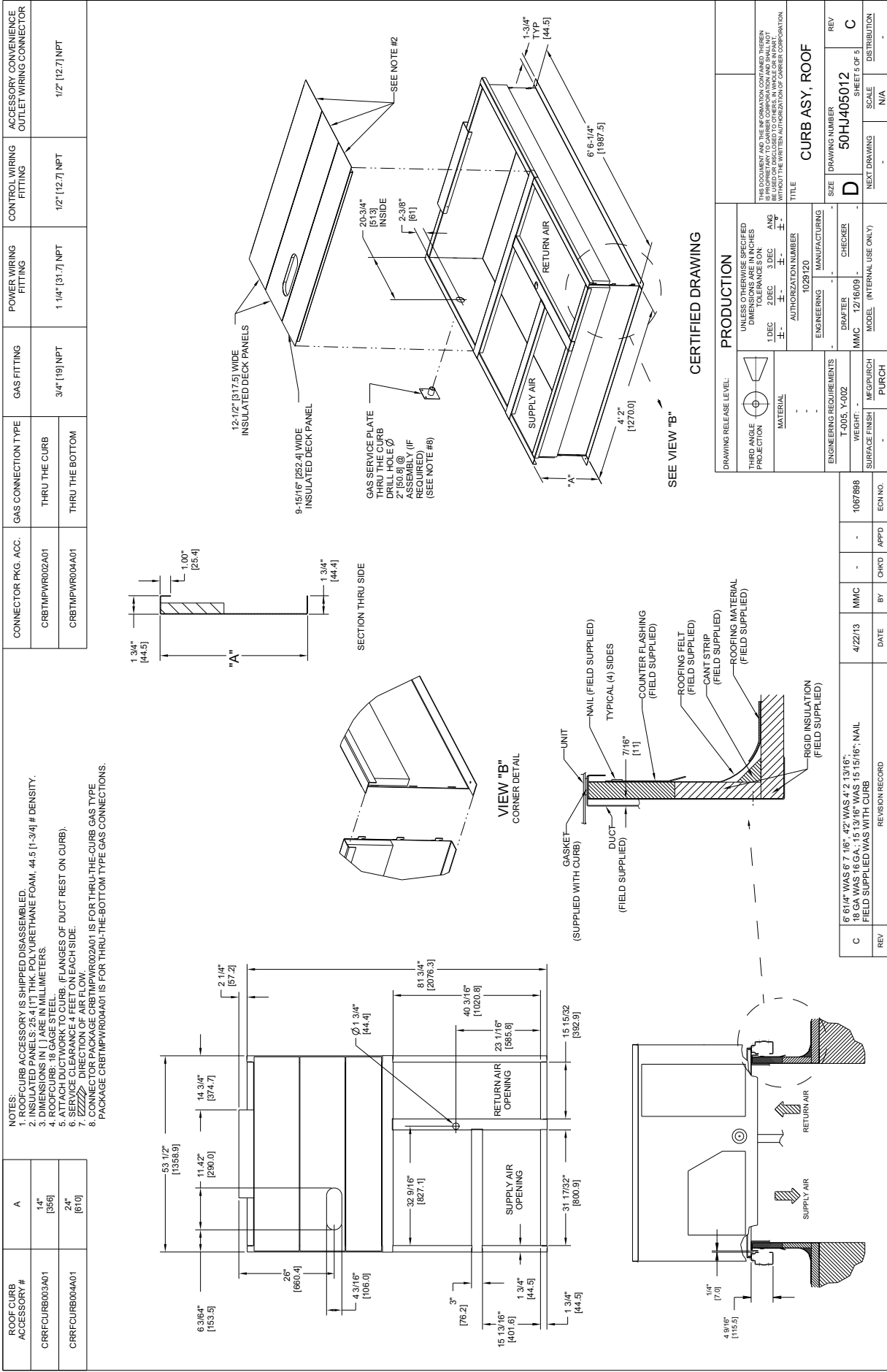

Fig. 4 - Roof Curb Details

Curb should be level. This is necessary for unit drain to function properly. Unit leveling tolerances are shown in Fig. 5. Refer to Accessory Roof Curb Installation Instructions for additional information as required.

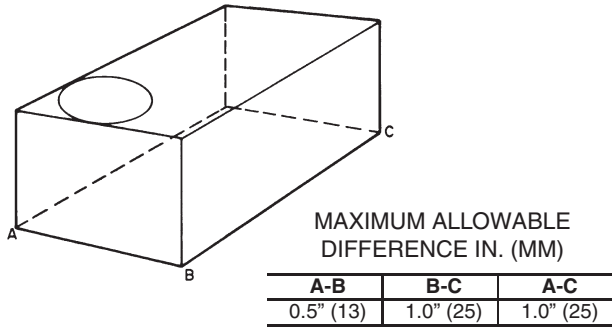

Fig. 5 - Unit Leveling Tolerances

C06110

Install insulation, cant strips, roofing felt, and counter flashing as shown. *Ductwork must be attached to curb and not to the unit. The accessory thru-the-base power and gas connection package must be installed before the unit is set on the roof curb.* If field-installed thru-the-roof curb gas connections are desired, use factory-supplied 1/2-in. pipe coupling and gas plate assembly to mount the thru-the-roof curb connection to the roof curb. Gas connections and power connections to the unit must be field-installed after the unit is installed on the roof curb.

If electric and control wiring is to be routed through the basepan, attach the accessory thru-the-base service connections to the basepan in accordance with the accessory installation instructions.

Slab Mount (Horizontal Units Only) —

Provide a level concrete slab that extends a minimum of 6 in. (150 mm) beyond unit cabinet. Install a gravel apron in front of condenser coil air inlet to prevent grass and foliage from obstructing airflow.

NOTE: Horizontal units may be installed on a roof curb if required.

Alternate Unit Support (In Lieu of Curb or Slab Mount) —

A non-combustible sleeper rail can be used in the unit curb support area. If sleeper rails cannot be used, support the long sides of the unit with a minimum of 3 equally spaced 4-in. x 4-in. (102 mm x 102 mm) pads on each side.

Step 5 — Field Fabricate Ductwork

Cabinet return-air static pressure (a negative condition) shall not exceed 0.35 in. wg (87 Pa) with economizer or 0.45 in. wg (112 Pa) without economizer.

For vertical ducted applications, secure all ducts to roof curb and building structure. *Do not connect ductwork to unit.*

Fabricate supply ductwork so that the cross sectional dimensions are equal to or greater than the unit supply duct opening dimensions for the first 18 in. (458 mm) of duct length from the unit basepan.

Insulate and weatherproof all external ductwork, joints, and roof openings with counter flashing and mastic in accordance with applicable codes.

Ducts passing through unconditioned spaces must be insulated and covered with a vapor barrier.

If a plenum return is used on a vertical unit, the return should be ducted through the roof deck to comply with applicable fire codes.

A minimum clearance is not required around ductwork.

⚠ CAUTION

PROPERTY DAMAGE HAZARD

Failure to follow this caution may result in damage to roofing materials.

Membrane roofs can be cut by sharp sheet metal edges. Be careful when placing any sheet metal parts on such roof.

Step 6 — Rig and Place Unit

Keep unit upright and do not drop. Spreader bars are required. Rollers may be used to move unit across a roof. Level by using unit frame as a reference. See Table 1 and Fig. 6 for additional information.

Lifting holes are provided in base rails as shown in Fig. 6. Refer to rigging instructions on unit.

Rigging materials under unit (cardboard or wood) must be removed **PRIOR** to placing the unit on the roof curb.

When using the standard side drain connection, ensure the red plug in the alternate bottom connection is tight. Do this before setting the unit in place. The red plug can be tightened with a 1/2-in. square socket drive extension. For further details see Step 11 — Install External Condensate Trap and Line on page 16.

Before setting the unit onto the curb, recheck gasketing on curb.

⚠ CAUTION

UNIT DAMAGE HAZARD

Failure to follow this caution may result in equipment damage.

All panels must be in place when rigging. Unit is not designed for handling by fork truck when packaging is removed.

If using top crate as spreader bar, once unit is set, carefully lower wooden crate off building roof top to ground. Ensure that no people or obstructions are below prior to lowering the crate.

⚠ CAUTION - NOTICE TO RIGGERS:
⚠ AVERTISSEMENT - REMARQUE À L'ATTENTION DES MONTEURS

ALL PANELS MUST BE IN PLACE WHEN RIGGING.
TOUS LES CAPOTS DOIVENT ÊTRE EN PLACE AVANT LE LEVAGE

- Hook rigging shackles through holes in base rail, as shown in Detail "A".
- Use wooden top skid, when rigging, to prevent rigging straps from damaging unit.
- Max weight includes base unit plus shipping pallet plus all available FIOP's which could be on that size unit.
- "B" dimension is based on base unit plus economizer option only. This dimension may vary slightly with units configured with other FIOP options.
- Spreader bars required to lift and transport the unit.
- Accrocher les manilles des élingues de levages dans les trous situés dans le rail de base comme indiqué au Détail "A".
- Utiliser des cales en bois lors du levage pour éviter que les élingues n'endommagent le haut de l'appareil.
- Le poids maximum inclut la configuration de base, le poids de la palette d'expédition, ainsi que toutes les options pouvant être installées en usine (FIOP) pour la plateforme sélectionnée.
- La dimension de "B" provient de la configuration de base qui inclut l'option economizer seulement. Cette dimension peut varier légèrement en fonction des différentes options sélectionnées installées en usine (FIOP).
- Barres d'écartement requises pour soulever et transporter l'unité.

PLACE ALL SEAL STRIP IN PLACE BEFORE PLACING UNIT ON ROOF CURB.
 INSTALLER TOUTES LES BANDES D'ISOLATION EN PLACE AVANT DE PLACER L'APPAREIL SUR LE REBORD DE TOIT.

DUCT END
 PASSAGES CONDUITES

DETAIL A
DÉTAIL "A"

MODEL	MAX WEIGHT		A		B		C	
	LB	KG	IN	MM	IN	MM	IN	MM
48LC_007	1145	520	88	2235	32	812	49 1/2	1257
50LC_007	1080	491	88	2235	30 3/8	772	49 1/2	1257

48TM504503 REV -

C13094

Fig. 6 - Rigging Label

Positioning on Curb —

Position unit on roof curb so that the following clearances are maintained: 1/4 in. (6.4 mm) clearance between the roof curb and the base rail inside the front and back, 0.0 in. clearance between the roof curb and the base rail inside on the duct end of the unit. This will result in the distance between the roof curb and the base rail inside on the condenser end of the unit being approximately 3-5/16 in. (84 mm).

Although unit is weatherproof, guard against water from higher level runoff and overhangs.

Flue vent discharge must have a minimum horizontal clearance of 4 ft (1220 mm) from electric and gas meters, gas regulators, and gas relief equipment. Minimum distance between unit and other electrically live parts is 48 in. (1220 mm).

Flue gas can deteriorate building materials. Orient unit such that flue gas will not affect building materials.

Locate mechanical draft system flue assembly at least 48 in. (1220 mm) from an adjacent building or combustible material.

NOTE: Installation of accessory flue discharge deflector kit will reduce the minimum clearance to combustible material to 18 in. (460 mm).

After the unit is in position remove all riggings, shipping materials and top skid. Recycle or dispose of all shipping materials.

Step 7 — Convert to Horizontal and Connect Ductwork (when required)

Unit is shipped in the vertical duct configuration. Unit without factory-installed economizer or return air smoke detector option may be field-converted to horizontal ducted configuration. To convert to horizontal configuration, remove screws from side duct opening covers and remove covers. Using the same screws, install covers on vertical duct openings with the insulation-side down. Seals around duct openings must be tight. See Fig. 7.

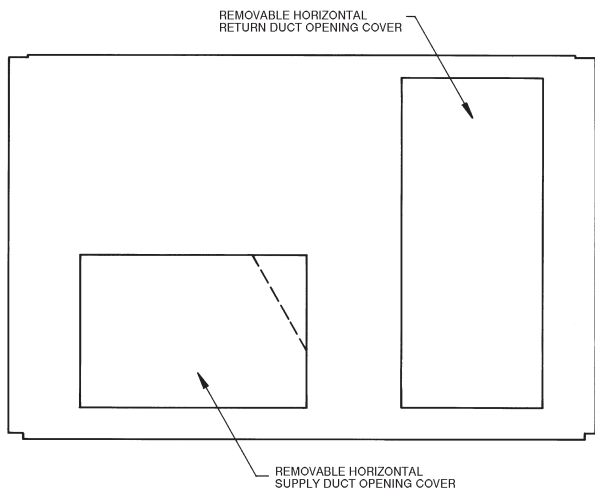

C06108

Fig. 7 - Horizontal Conversion Panels

Field-supplied flanges should be attached to horizontal duct openings and all ductwork should be secured to the flanges. Insulate and weatherproof all external ductwork, joints, and roof or building openings with counter flashing and mastic in accordance with applicable codes.

Do not cover or obscure visibility to the unit's informative data plate when insulating horizontal ductwork.

Step 8 — Install Outside Air Hood

Economizer Hood Package Removal and Setup - Factory Option

1. The hood is shipped in knock-down form and must be field assembled. The indoor coil access panel is used as the hood top while the hood sides, divider and filter are packaged together, attached to a metal support tray using plastic stretch wrap, and shipped in the return air compartment behind the indoor coil access panel. The hood assembly's metal tray is attached to the basepan and also attached to the damper using two plastic tie-wraps.
2. To gain access to the hood, remove the filter access panel. (See Fig. 8.)

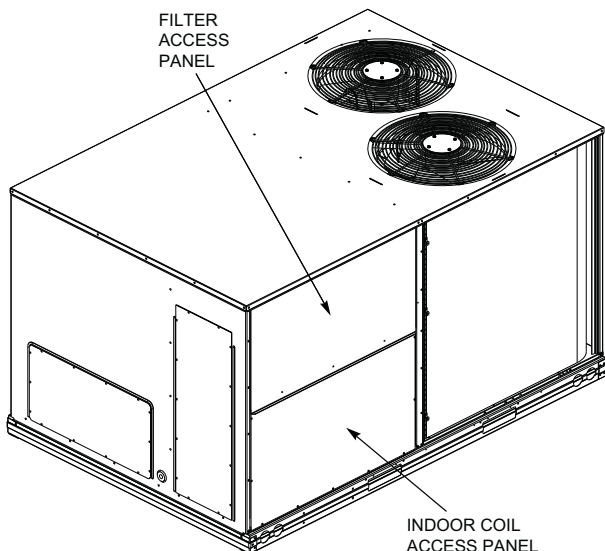

C13095

Fig. 8 - Access Panel Locations

3. Locate the (2) screws holding the metal tray to the basepan and remove. Locate and cut the (2) plastic tie-wraps securing the assembly to the damper. (See Fig. 9.) Be careful to not damage any wiring or cut tie-wraps securing any wiring.

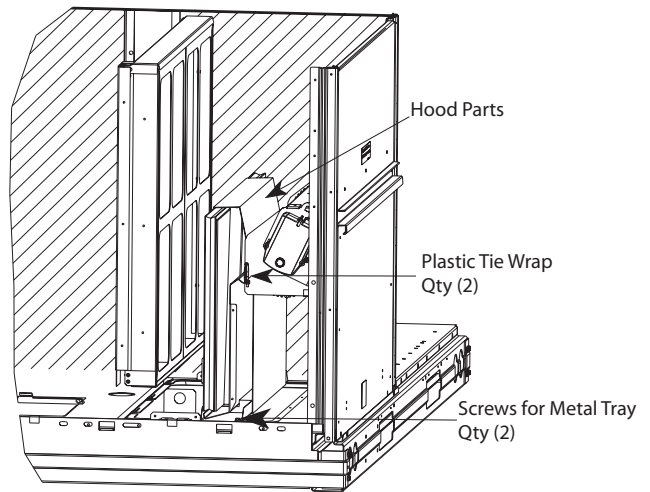

C08639

Fig. 9 - Economizer Hood Parts Location

4. Carefully lift the hood assembly (with metal tray) through the filter access opening and assemble per the steps outlined in *Economizer Hood*, below.

Economizer Hood —

NOTE: If the power exhaust accessory is to be installed on the unit, the hood shipped with the unit will not be used and must be discarded. Save the aluminum filter for use in the power exhaust hood assembly.

1. The indoor coil access panel will be used as the top of the hood. Remove the screws along the sides and bottom of the indoor coil access panel. See Fig. 10.

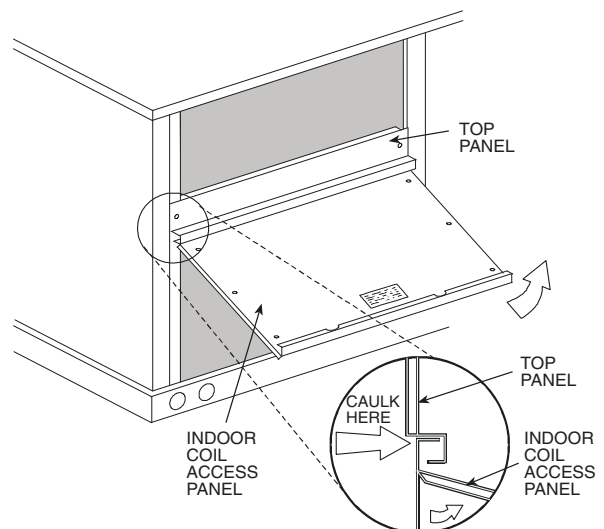

C06025

Fig. 10 - Indoor Coil Access Panel Relocation

2. Swing out indoor coil access panel and insert the hood sides under the panel (hood top). Use the screws provided to attach the hood sides to the hood top. Use screws provided to attach the hood sides to the unit. See Fig. 11.

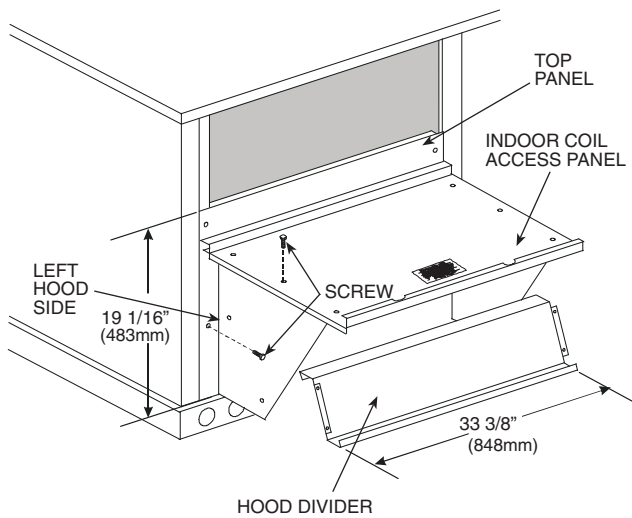

Fig. 11 - Economizer Hood Construction

C06026

3. Remove the shipping tape holding the economizer barometric relief damper in place (economizer only).
4. Insert the hood divider between the hood sides. See Fig. 11 and 12. Secure hood divider with 2 screws on each hood side. The hood divider is also used as the bottom filter rack for the aluminum filter.
5. Open the filter clips which are located underneath the hood top. Insert the aluminum filter into the bottom filter rack (hood divider). Push the filter into position past the open filter clips. Close the filter clips to lock the filter into place. See Fig. 12.
6. Caulk the ends of the joint between the unit top panel and the hood top.
7. Replace the filter access panel.

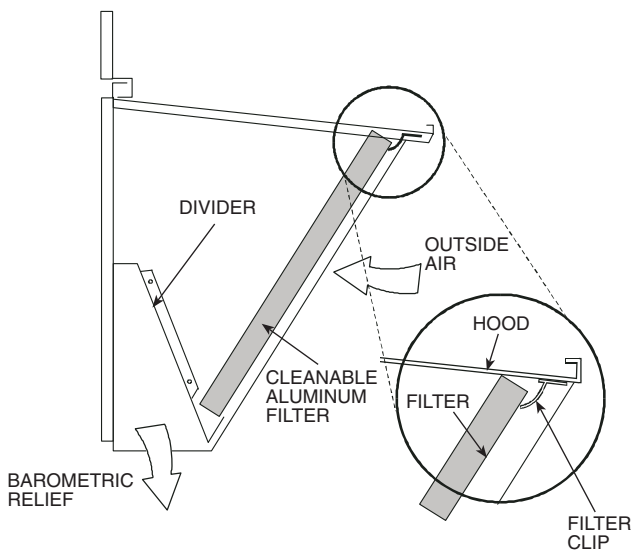

Fig. 12 - Economizer Filter Installation

C08634

Step 9 — Install Flue Hood

Flue hood is shipped screwed to the basepan beside the burner compartment access panel. Remove from shipping location and using screws provided, install flue hood and screen in location shown in Fig. 13.

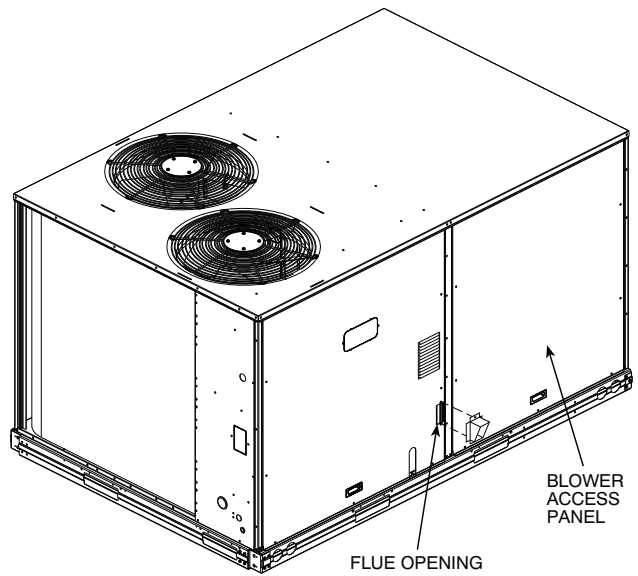

Fig. 13 - Flue Hood Details

C13096

Step 10 — Install Gas Piping

Installation of the gas piping must be accordance with local building codes and with applicable national codes. In U.S.A., refer to NFPA 54/ANSI Z223.1 National Fuel Gas Code (NFGC). In Canada, installation must be accordance with the CAN/CSA B149.1 and CAN/CSA B149.2 installation codes for gas burning appliances.

This unit is factory equipped for use with Natural Gas fuel at elevations up to 2000 ft (610 m) above sea level. Unit may be field converted for operation at elevations above 2000 ft (610 m) and/or for use with liquefied petroleum fuel. See accessory kit installation instructions regarding these accessories.

NOTE: Furnace gas input rate on rating plate is for installation up to 2000 ft (610 m) above sea level. In U.S.A. the input rating for altitudes above 2000 ft (610 m) must be derated by 4% for each 1000 ft (305 m) above sea level.

For natural gas applications, gas pressure at unit gas connection must not be less than 4 in. wg (996 Pa) or greater than 13 in. wg (3240 Pa) while the unit is operating. On 48LCF/T007 (high-heat) units, the gas pressure at unit gas connection must not be less than 5 in. wg (1245 Pa) or greater than 13 in. wg (3240 Pa) while the unit is operating. For liquefied petroleum applications, the gas pressure must not be less than 11 in. wg (2740 Pa) or greater than 13.0 in. wg (3240 Pa) at the unit connection.

Table 2 – Natural Gas Supply Line Pressure Ranges

UNIT MODEL	UNIT SIZE	MIN	MAX
48LCD/E/S/R0	07	4.0 in. wg (996 Pa)	13.0 in. wg (3240 Pa)
48LCF/T0 (High Heat units only)	07	5.0 in. wg (1245 Pa)	13.0 in. Wg (3240 Pa)

Table 3 – Liquid Propane Supply Line Pressure Ranges

UNIT MODEL	UNIT SIZE	MIN	MAX
48LCD/F/E/S/R/T0	07	11.0 in. wg (2740 Pa)	13.0 in. wg (3240 Pa)

The gas supply pipe enters the unit at the burner access panel on the front side of the unit, through the long slot at the bottom of the access panel. The gas connection to the unit is made to the 3/4-in. FPT gas inlet port on the unit gas valve.

Manifold pressure is factory-adjusted for natural gas (NG) fuel use. Adjust as required to obtain best flame characteristics.

Table 4 – Natural Gas Manifold Pressure Ranges

UNIT MODEL	UNIT SIZE	HIGH FIRE	LOW FIRE
48LCD/E/S/R0	07	3.5 in. wg (872 Pa)	1.7 in. wg (423 Pa)
48LCF/T0 (High Heat units only)	07	3.5 in. wg (872 Pa)	2.0 in. wg (498 Pa)

Manifold pressure for liquid propane (LP) fuel use must be adjusted to specified range. Follow instructions in the accessory kit to make initial readjustment.

Table 5 – Liquid Propane Manifold Pressure Ranges

UNIT MODEL	UNIT SIZE	HIGH FIRE	LOW FIRE
48LCD/E/S/R0	07	10.0 in. wg (2490 Pa)	5.0 in. wg (1245 Pa)
48LCF/T0 (High Heat units only)	07	10.0 in. wg (2490 Pa)	5.7 in. wg (1420 Pa)

⚠ CAUTION

EQUIPMENT DAMAGE HAZARD

Failure to follow this caution may result in damage to equipment.

When connecting the gas line to the unit gas valve, the installer **MUST** use a backup wrench to prevent damage to the valve.

Install a gas supply line that runs to the unit heating section. Refer to the NFPA 54/NFPA or equivalent code for gas pipe sizing data. Do not use a pipe size smaller than 1/2-in. Size the gas supply line to allow for a maximum pressure drop of 0.5-in. wg (124 Pa) between gas regulator source and unit gas valve connection when unit is operating at high-fire flow rate.

The gas supply line can approach the unit in three ways: horizontally from outside the unit (across the roof), thru-curb/under unit basepan (accessory kit required) or through unit basepan (factory-option or accessory kit

required). Consult accessory kit installation instructions for details on these installation methods. Observe clearance to gas line components per Fig. 14.

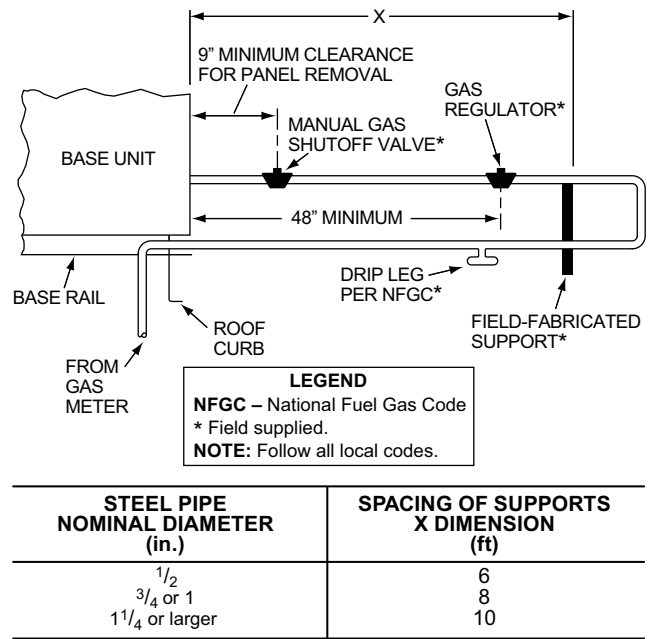

Fig. 14 - Gas Piping Guide (with Accessory Thru-the-Curb Service Connections)

Factory-Option Thru-Base Connections (Gas Connections) —

This service connection kit consists of a 3/4-in. NPT gas adapter fitting (brass), two 1/2-in. electrical bulkhead connectors and a 3/4-in. electrical bulkhead connector, all factory-installed in the embossed (raised) section of the unit basepan in the condenser section.

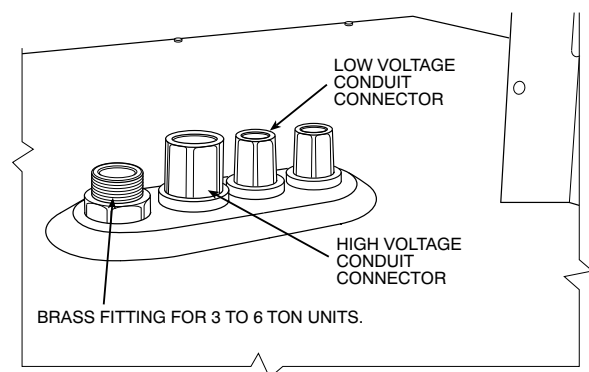
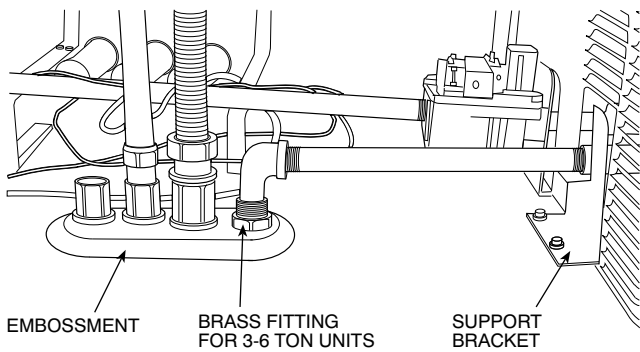

Fig. 15 - Fittings

The thru-base gas connector has male and female threads. The male threads protrude above the basepan of the unit; the female threads protrude below the basepan.

Check tightness of connector lock nuts before connecting gas piping.

Install a 3/4-in NPT street elbow on the thru-base gas fitting. Attach a 3/4-in. pipe nipple with minimum length of 16-in. (406 mm) (field-supplied) to the street elbow and extend it through the access panel at the gas support bracket. See Fig. 16.



C13411

Fig. 16 - Gas Line Piping for 6 Ton Units

Other hardware required to complete the installation of the gas supply line will include a manual shutoff valve, a sediment trap (drip leg) and a ground-joint union. A pressure regulator valve may also be required (to convert gas pressure from pounds to inches of pressure). The manual shutoff valve must be located within 6-ft (1.83 m) of the unit. The union, located in the final leg entering the unit, must be located at least 9-in. (230 mm) away from the access panel to permit the panel to be removed for service. If a regulator valve is installed, it must be located a minimum of 4-ft (1220 mm) away from the unit's flue outlet. Some municipal codes require that the manual shutoff valve be located upstream of the sediment trap. See Fig. 17 and 18 for typical piping arrangements for gas piping that has been routed through the sidewall of the curb. See Fig. 19 for typical piping arrangement when thru-base is used. Ensure that all piping does not block access to the unit's main control box or limit the required working space in front of the control box.

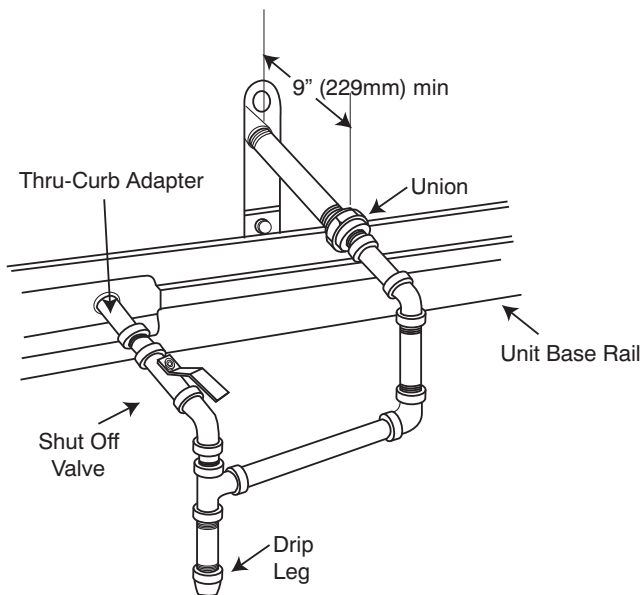

C07469

Fig. 17 - Gas Piping with Direct Drip Leg

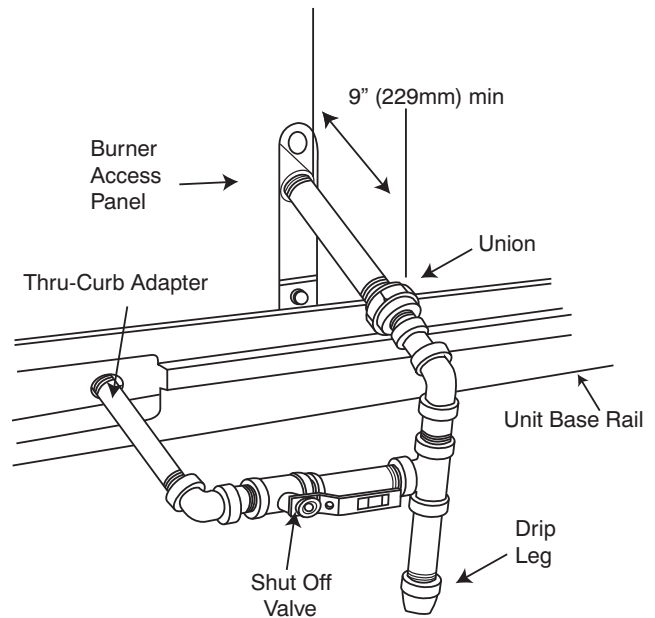

C07470

Fig. 18 - Gas Piping with Offset Drip Leg

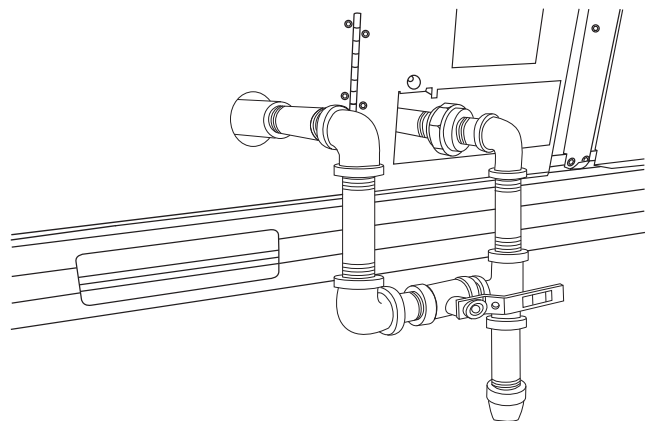

C08018

Fig. 19 - Gas Piping Thru-Base Connections

When installing the gas supply line, observe local codes pertaining to gas pipe installations. Refer to the NFPA 54/ANSI Z223.1 NFGC latest edition (in Canada, CAN/CSA B149.1). In the absence of local building codes, adhere to the following pertinent recommendations:

1. Avoid low spots in long runs of pipe. Grade all pipe $\frac{1}{4}$ -in. in every 15 ft (7 mm in every 5 m) to prevent traps. Grade all horizontal runs downward to risers. Use risers to connect to heating section and to meter.
2. Protect all segments of piping system against physical and thermal damage. Support all piping with appropriate straps, hangers, etc. Use a minimum of one hanger every 6 ft (1.8 m). For pipe sizes larger than $\frac{1}{2}$ -in., follow recommendations of national codes.
3. Apply joint compound (pipe dope) sparingly and only to male threads of joint when making pipe connections. Use only pipe dope that is resistant to action of liquefied petroleum gases as specified by local and/or national codes. If using PTFE (Teflon*) tape, ensure the material is Double Density type and is labeled for use on gas lines. Apply tape per manufacturer's instructions.

* Teflon is a registered trademark of DuPont.

4. Pressure-test all gas piping in accordance with local and national plumbing and gas codes before connecting piping to unit.

NOTE: Pressure test the gas supply system after the gas supply piping is connected to the gas valve. The supply piping must be disconnected from the gas valve during the testing of the piping systems when test pressure is in excess of 0.5 psig (3450 Pa). Pressure test the gas supply piping system at pressures equal to or less than 0.5 psig (3450 Pa). The unit heating section must be isolated from the gas piping system by closing the external main manual shutoff valve and slightly opening the ground-joint union.

Check for gas leaks at the field-installed and factory-installed gas lines after all piping connections have been completed. Use soap-and-water solution (or method specified by local codes and/or regulations).

⚠ WARNING

FIRE OR EXPLOSION HAZARD

Failure to follow this warning could result in personal injury, death and/or property damage.

- Connect gas pipe to unit using a backup wrench to avoid damaging gas controls.
- Never purge a gas line into a combustion chamber.
- Never test for gas leaks with an open flame. Use a commercially available soap solution made specifically for the detection of leaks to check all connections.
- Use proper length of pipe to avoid stress on gas control manifold.

NOTE: If orifice hole appears damaged or it is suspected to have been redrilled, check orifice hole with a numbered drill bit of correct size. Never redrill an orifice. A burr-free and squarely aligned orifice hole is essential for proper flame characteristics.

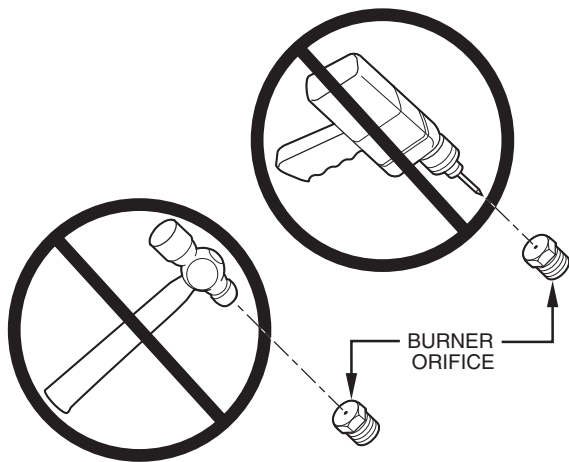

Fig. 20 - Orifice Hole

A93059

Step 11 — Install External Condensate Trap and Line

The unit has one $\frac{3}{4}$ -in. condensate drain connection on the end of the condensate pan and an alternate connection on the bottom. See Fig. 21. Unit airflow configuration does not determine which drain connection to use. Either drain connection can be used with vertical or horizontal applications.

To use the alternate bottom drain connection, remove the red drain plug from the bottom connection (use a $\frac{1}{2}$ -in. square socket drive extension) and install it in the side drain connection.

The piping for the condensate drain and external trap can be completed after the unit is in place. See Fig. 22.

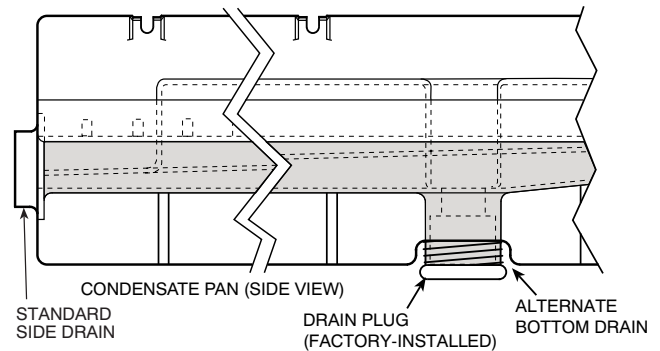

C08021

Fig. 21 - Condensate Drain Pan (Side View)

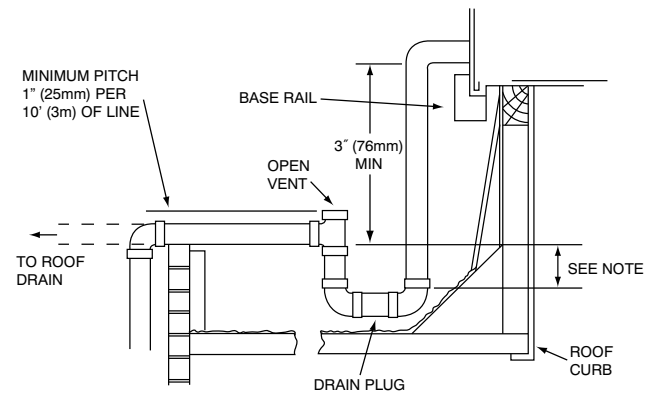

NOTE: Trap should be deep enough to offset maximum unit static difference. A 4" (102mm) trap is recommended.

C11291

Fig. 22 - Condensate Drain Piping Details

All units must have an external trap for condensate drainage. Install a trap at least 4-in. (102 mm) deep and protect against freeze-up. If drain line is installed downstream from the external trap, pitch the line away from the unit at 1-in. per 10 ft (25 mm in 3 m) of run. Do not use a pipe size smaller than the unit connection ($\frac{3}{4}$ -in.).

Step 12 — Make Electrical Connections

⚠ WARNING

ELECTRICAL SHOCK HAZARD

Failure to follow this warning could result in personal injury or death.

Do not use gas piping as an electrical ground. Unit cabinet must have an uninterrupted, unbroken electrical ground to minimize the possibility of personal injury if an electrical fault should occur. This ground may consist of electrical wire connected to unit ground lug in control compartment, or conduit approved for electrical ground when installed in accordance with NEC (National Electrical Code); ANSI/NFPA 70, latest edition (in Canada, Canadian Electrical Code CSA [Canadian Standards Association] C22.1), and local electrical codes.

NOTE: Field-supplied wiring shall conform with the limitations of minimum 63°F (33°C) rise.

Field Power Supply —

If equipped with optional Powered Convenience Outlet: The power source leads to the convenience outlet's transformer primary are not factory connected. Installer must connect these leads according to required operation of the convenience outlet. If an always-energized convenience outlet operation is desired, connect the source leads to the line side of the unit-mounted disconnect. (Check with local codes to ensure this method is acceptable in your area.) If a de-energize via unit disconnect switch operation of the convenience outlet is desired, connect the source leads to the load side of the unit disconnect. On a unit without a unit-mounted disconnect, connect the source leads to compressor contactor C and indoor fan contactor IFC pressure lugs with unit field power leads (see Fig. 23).

Refer to Fig. 38 for power transformer connections and the discussion on connecting the convenience outlet on page 26.

Field power wires will be connected line-side pressure lugs on the power terminal block or at factory-installed option non-fused disconnect or HACR.

Field power wires are connected to the unit at line-side pressure lugs on compressor contactor C and indoor fan contactor IFC (see wiring diagram label for control box component arrangement), at factory-installed option non-fused disconnect switch or HACR. Max wire size is #4 AWG (copper only) per pole on contactors and #2ga AWG (copper only) per pole on optional non-fused disconnect or HACR. See Fig. 23 and the unit label diagram for field power wiring connections.

NOTE: TEST LEADS - Unit may be equipped with short leads (pigtails) on the field line connection points on contactor C or optional disconnect switch. These leads are for factory run-test purposes only; remove and discard before connecting field power wires to unit connection points. Make field power connections directly to line connection pressure lugs only.

Units Without Disconnect or HACR Option

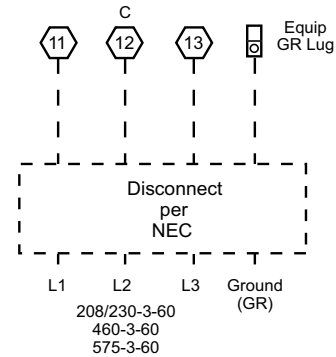

Units With Disconnect or HACR Option

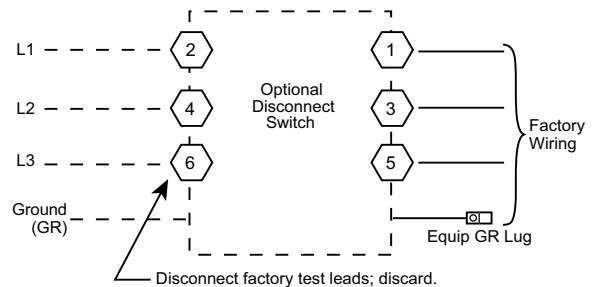

C13261

Fig. 23 - Power Wiring Connections

⚠ WARNING

FIRE HAZARD

Failure to follow this warning could result in intermittent operation or performance satisfaction.

Do not connect aluminum wire between disconnect switch and 48LC unit. Use only copper wire. (See Fig. 24.)

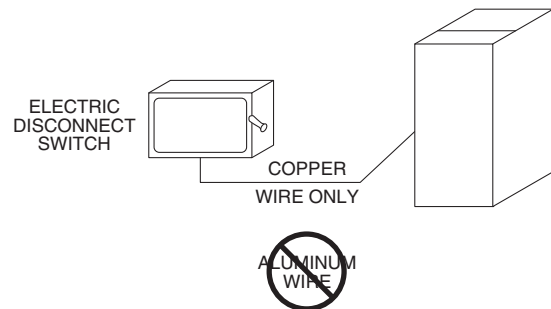

A93033

Fig. 24 - Disconnect Switch and Unit

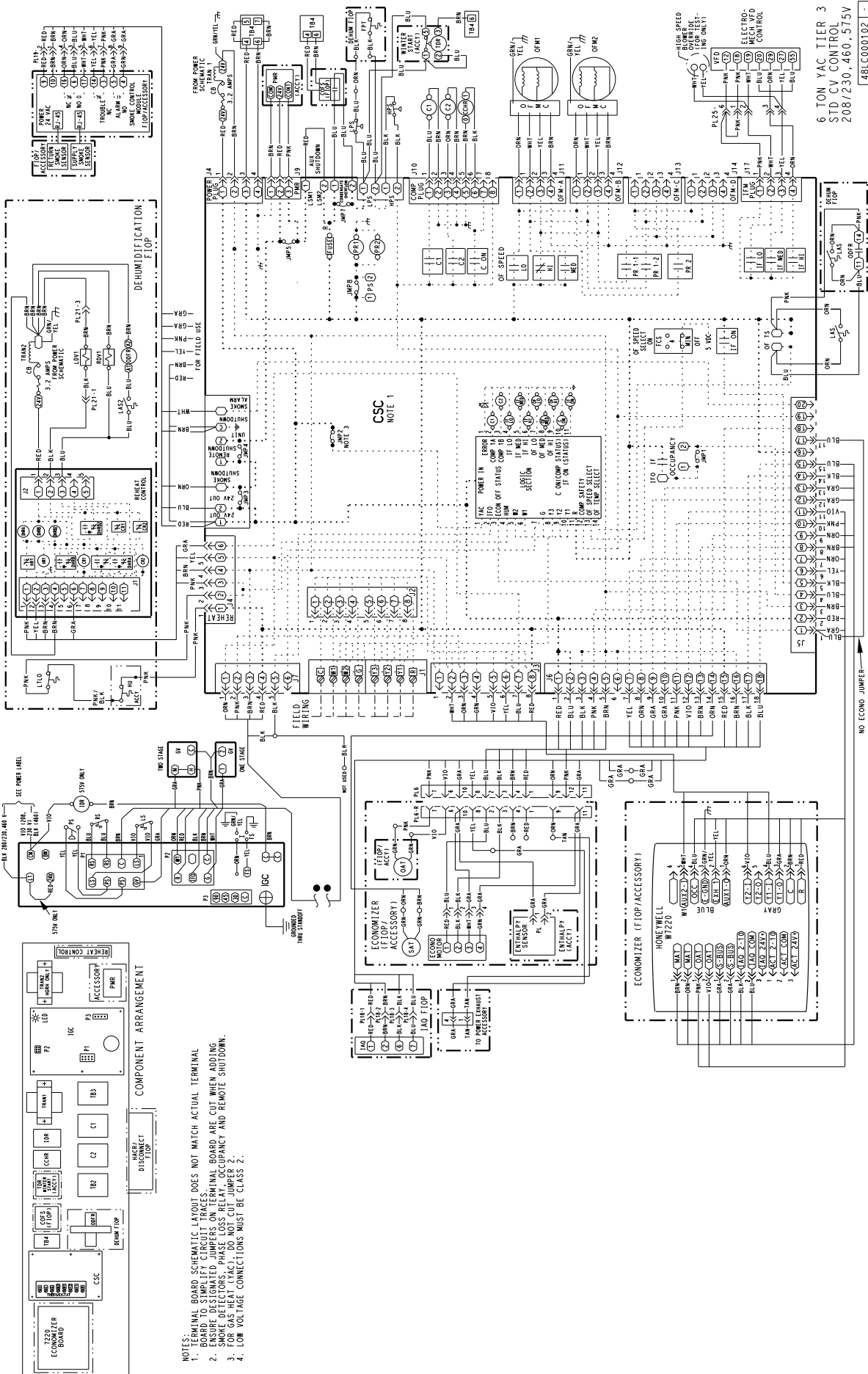
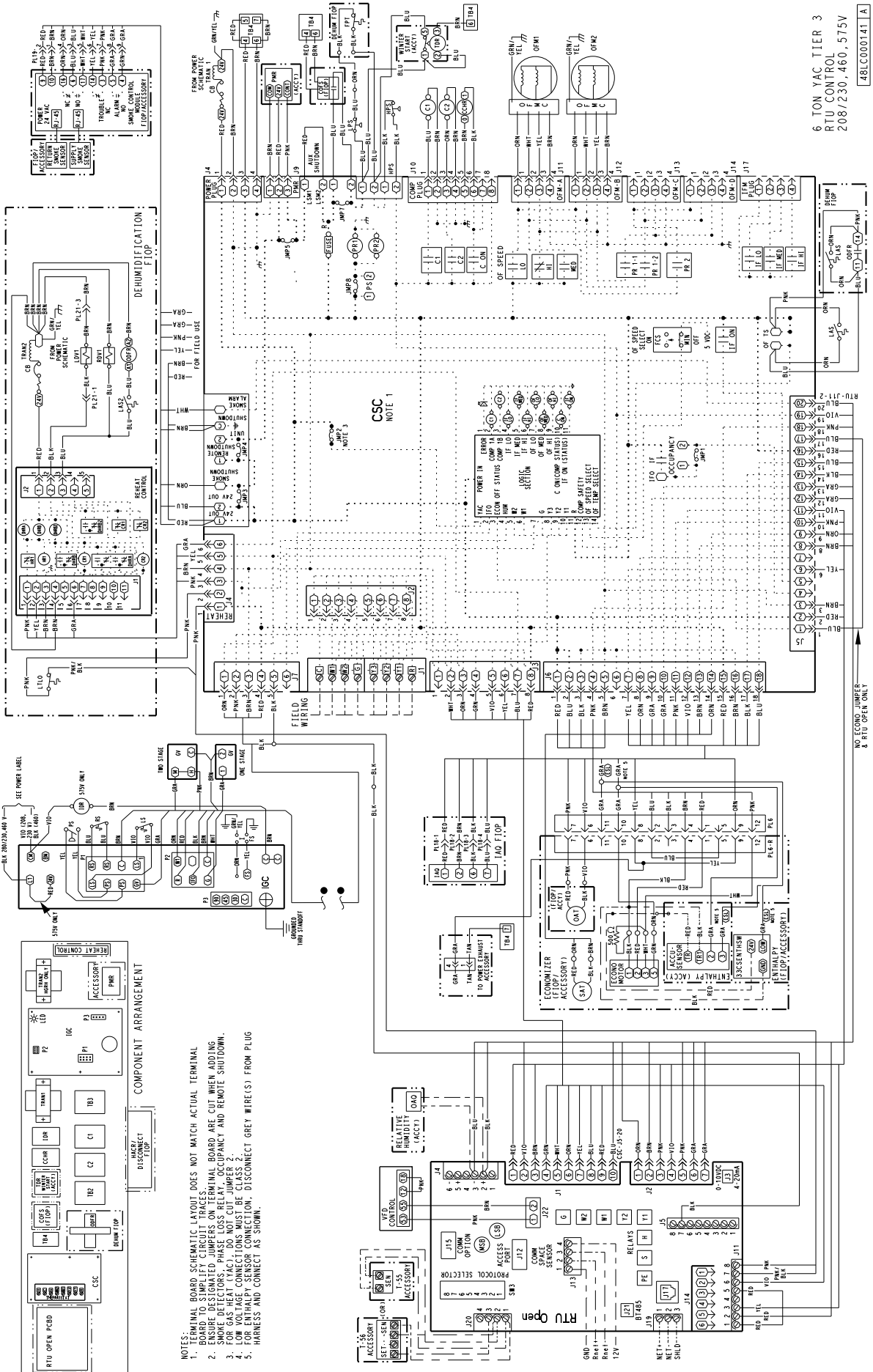

Fig. 25 - 48LC 07 Electro-mechanical Control Wiring Diagram



- NOTES:
1. TERMINAL BOARD SCHEMATIC LAYOUT DOES NOT MATCH ACTUAL TERMINAL BOARD. ENSURE DESIGNATED JUMPERS ON TERMINAL BOARD ARE CUT WHEN ADDING.
 2. SMOKE DETECTORS, PHASE LOSS RELAY, OCCUPANCY AND REMOTE SHUTDOWN.
 3. FOR GAS HEAT (HAC), DO NOT CUT JUMPER 2.
 4. FOR EXHAUSTY SENSOR CONNECTION, DISCONNECT GREY WIRE(S) FROM PLUG HARNESS AND CONNECT AS SHOWN.

Fig. 26 - 48LC 07 RTU Open Control Wiring Diagram

6 TON VAC TIER 3
PIC CONTROL FIOP
208/230, 460, 575V

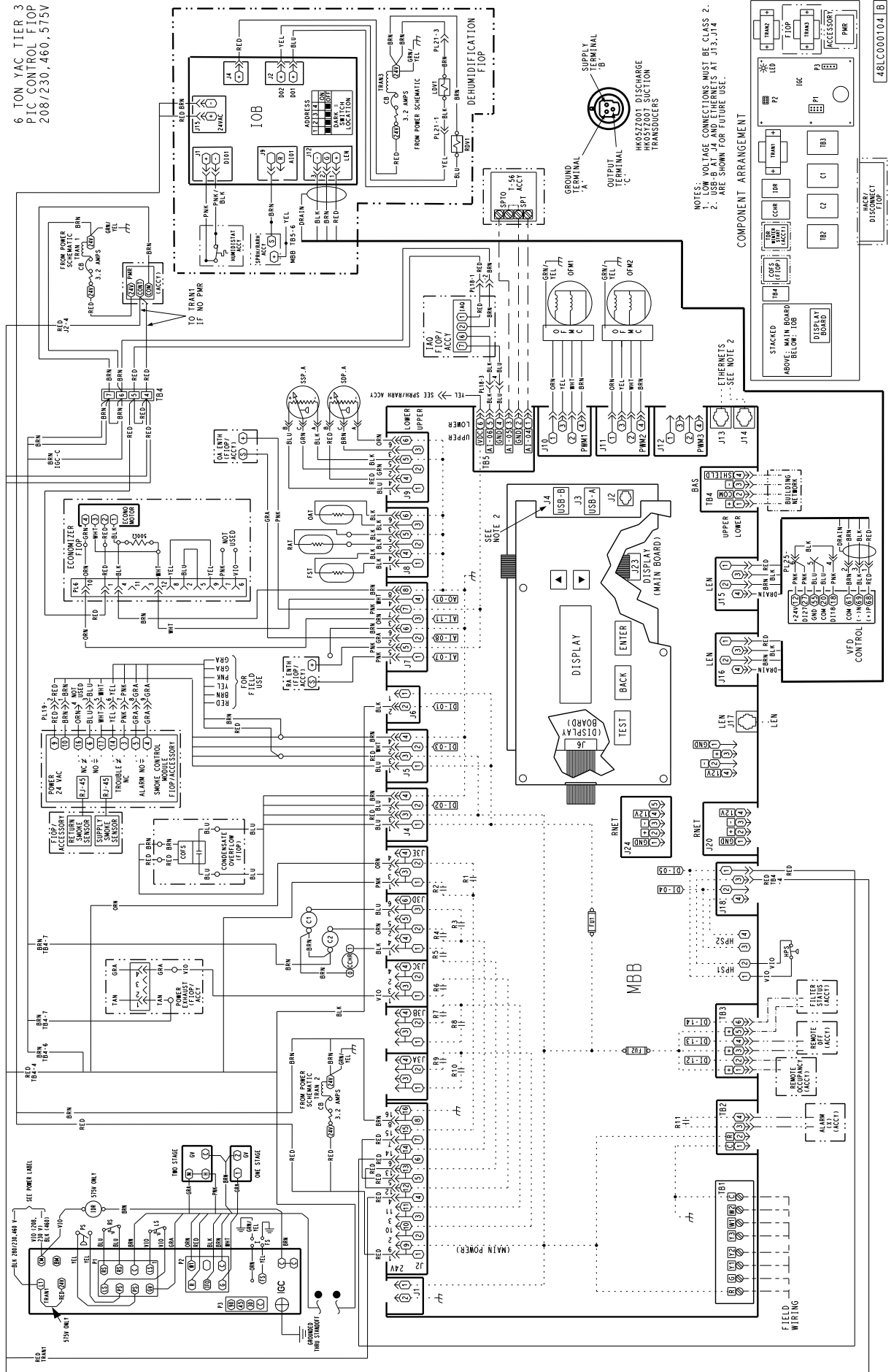
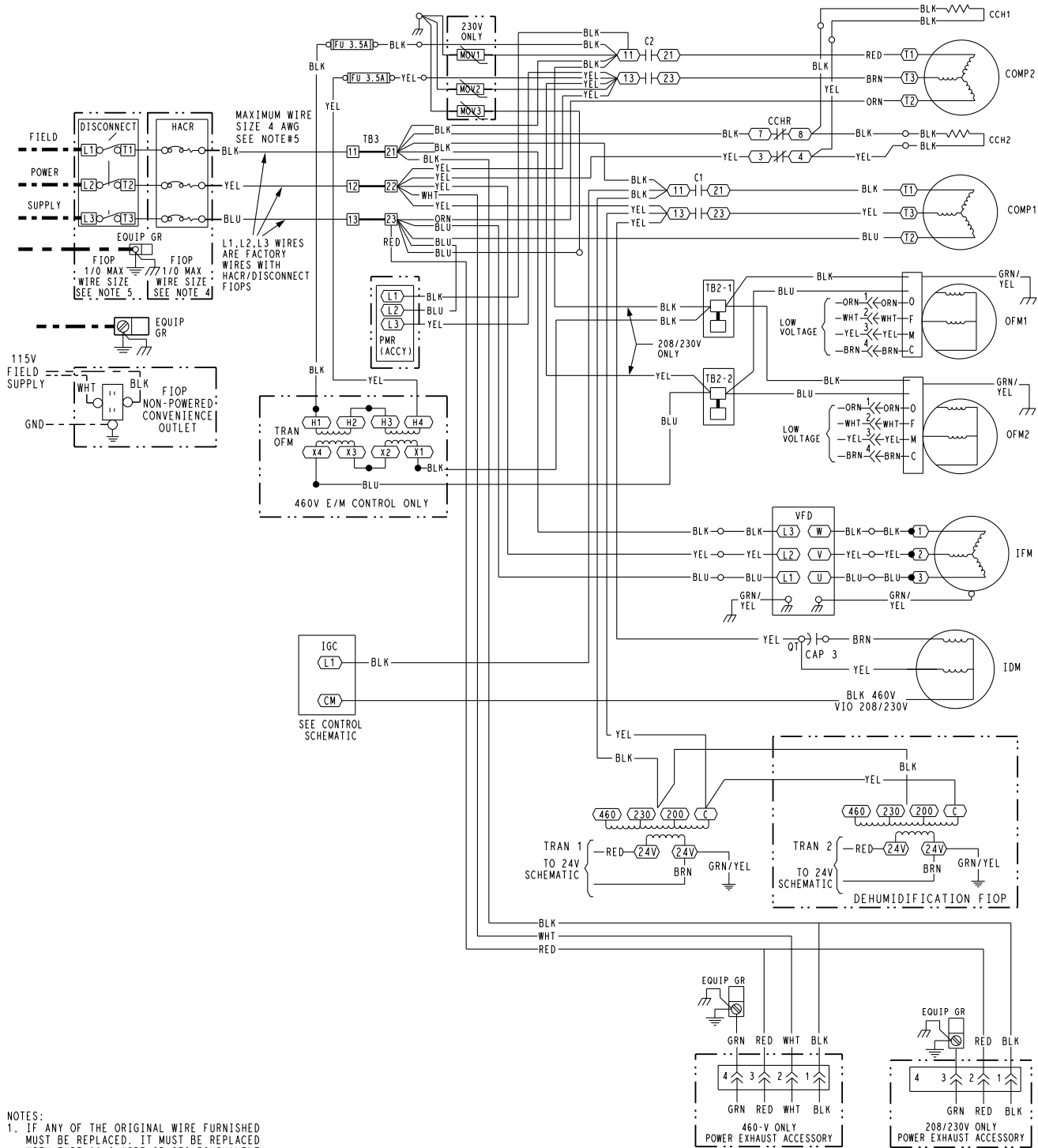

Fig. 27 - 48LC 07 SystemVu™ Control Wiring Diagram



- NOTES:
1. IF ANY OF THE ORIGINAL WIRE FURNISHED MUST BE REPLACED. IT MUST BE REPLACED WITH TYPE 90 C WIRE OR ITS EQUIVALENT.
 2. COMPRESSOR AND FAN MOTORS ARE THERMALLY PROTECTED. THREE PHASE MOTORS ARE PROTECTED AGAINST PRIMARY SINGLE PHASING CONDITIONS.
 3. 208/230V UNIT TRAN IS WIRED FOR 230V UNIT. IF UNIT IS TO BE RUN WITH 208V POWER SUPPLY DISCONNECT BLK WIRE FROM 230V TAP AND CONNECT TO 200V TAP.
 4. USE COPPER, COPPER CLAD ALUMINUM OR ALUMINUM CONDUCTORS.
 5. USE COPPER CONDUCTOR ONLY.

YAC POWER TIER3 - 6 TON 208/230,
460V 3Ø
48LC500463 B

a48-9325

Fig. 28 - 48LC 07 Power Wiring Diagram, Electro-mechanical and RTU Open Controls, 208/230V and 460V Units

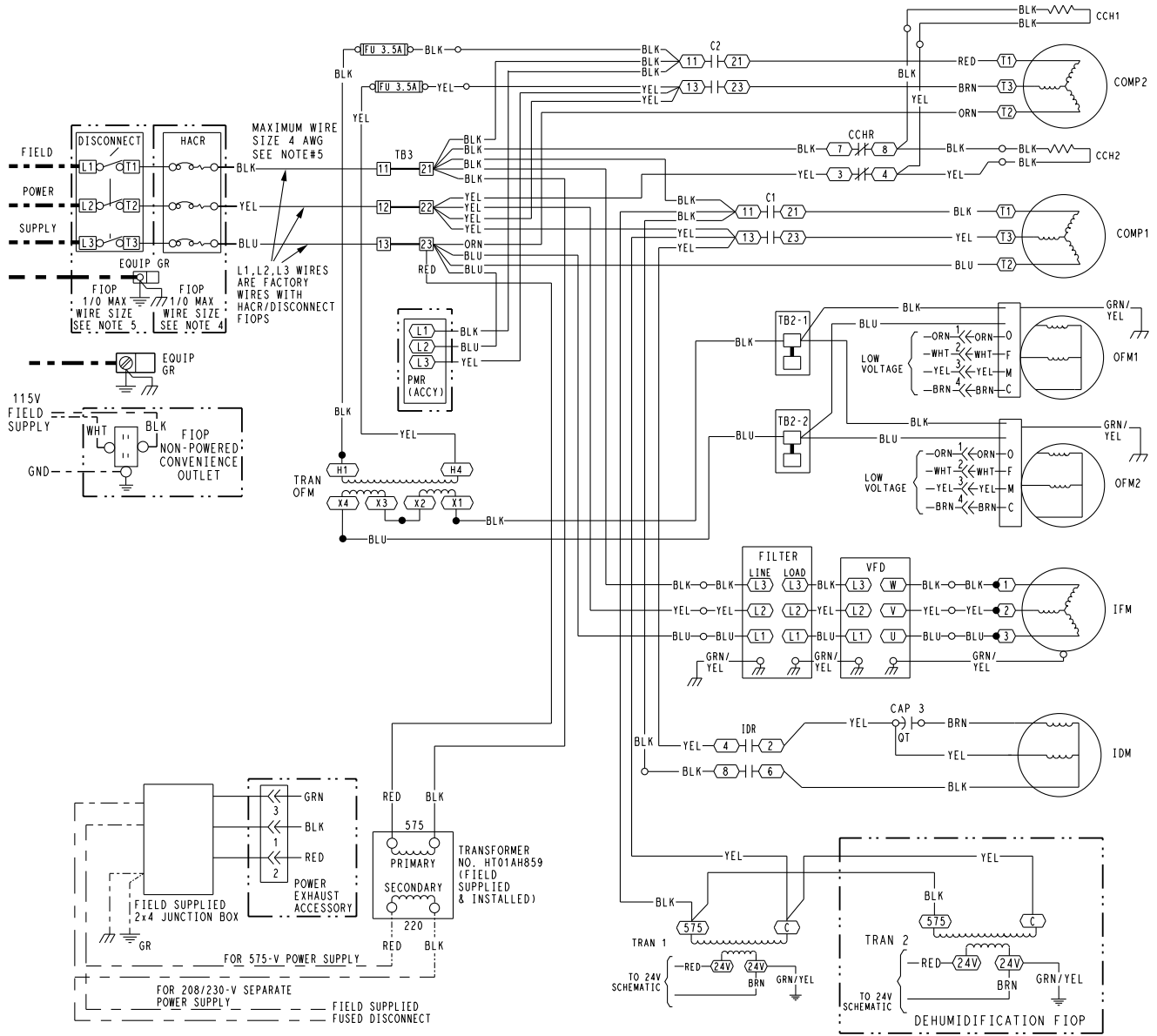

NOTES:

1. IF ANY OF THE ORIGINAL WIRE FURNISHED MUST BE REPLACED, IT MUST BE REPLACED WITH TYPE 90 C WIRE OR ITS EQUIVALENT.
2. COMPRESSOR AND FAN MOTORS ARE THERMALLY PROTECTED. THREE PHASE MOTORS ARE PROTECTED AGAINST PRIMARY SINGLE PHASING CONDITIONS.
3. TRAN 1 IS WIRED FOR 575V UNIT.
4. USE COPPER, COPPER CLAD ALUMINUM OR ALUMINUM CONDUCTORS.
5. USE COPPER CONDUCTOR ONLY.

YAC POWER TIER3 - 6 TON 575V 3Ø

48LC500464 B

a48-9326

Fig. 29 - 48LC 07 Power Wiring, Electro-mechanical and RTU Open Controls, Diagram, 575V Units

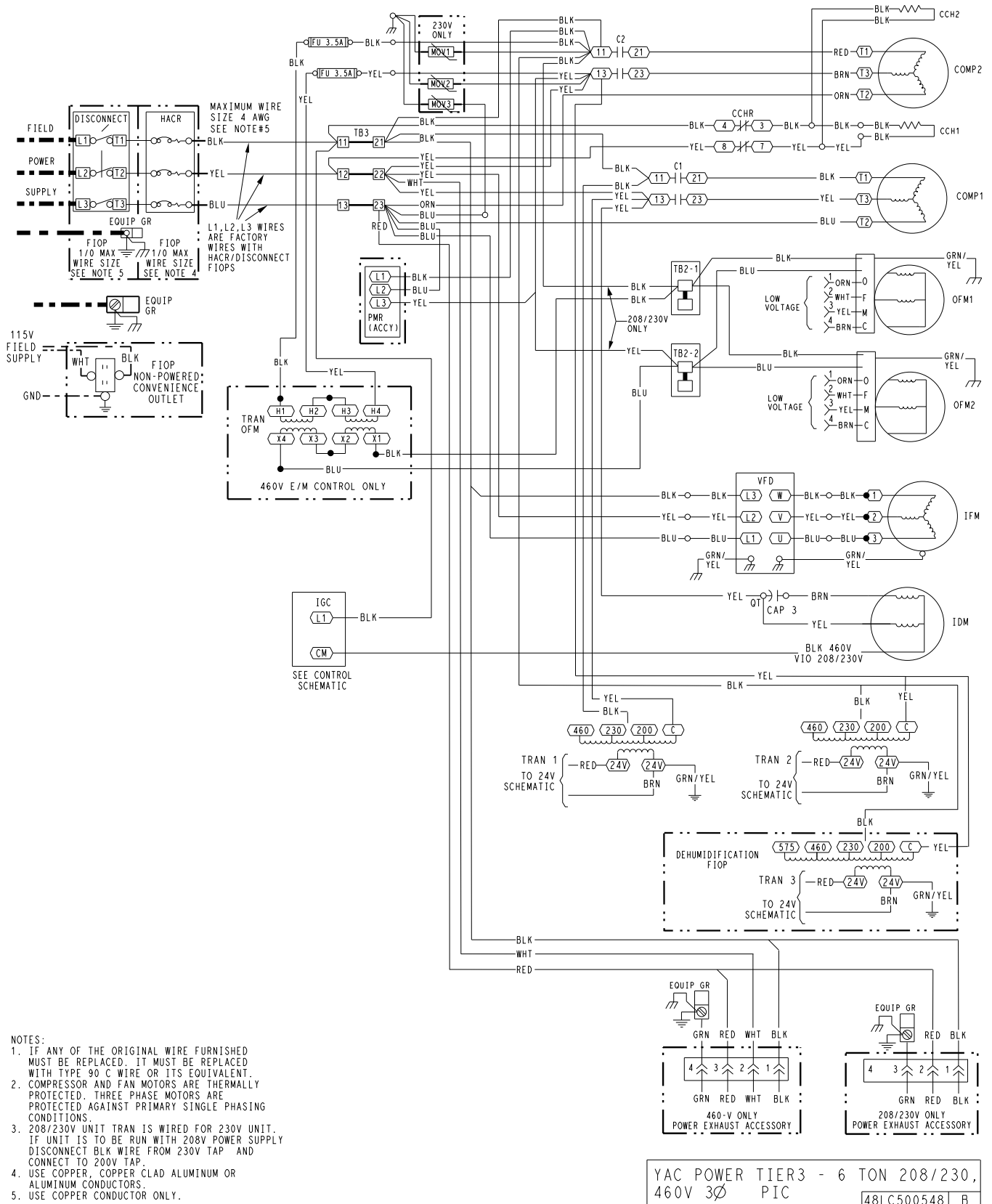

- NOTES:
1. IF ANY OF THE ORIGINAL WIRE FURNISHED MUST BE REPLACED, IT MUST BE REPLACED WITH TYPE 90 C WIRE OR ITS EQUIVALENT.
 2. COMPRESSOR AND FAN MOTORS ARE THERMALLY PROTECTED. THREE PHASE MOTORS ARE PROTECTED AGAINST PRIMARY SINGLE PHASING CONDITIONS.
 3. 208/230V UNIT TRAN IS WIRED FOR 230V UNIT. IF UNIT IS TO BE RUN WITH 208V POWER SUPPLY DISCONNECT BLK WIRE FROM 230V TAP AND CONNECT TO 200V TAP.
 4. USE COPPER, COPPER CLAD ALUMINUM OR ALUMINUM CONDUCTORS.
 5. USE COPPER CONDUCTOR ONLY.

YAC POWER TIER3 - 6 TON 208/230V, 460V 3Ø PIC 48LC500548 B

a48-9327

Fig. 30 - 48LC 07 Power Wiring Diagram, SystemVu™ Control, 208/230V and 460V Units

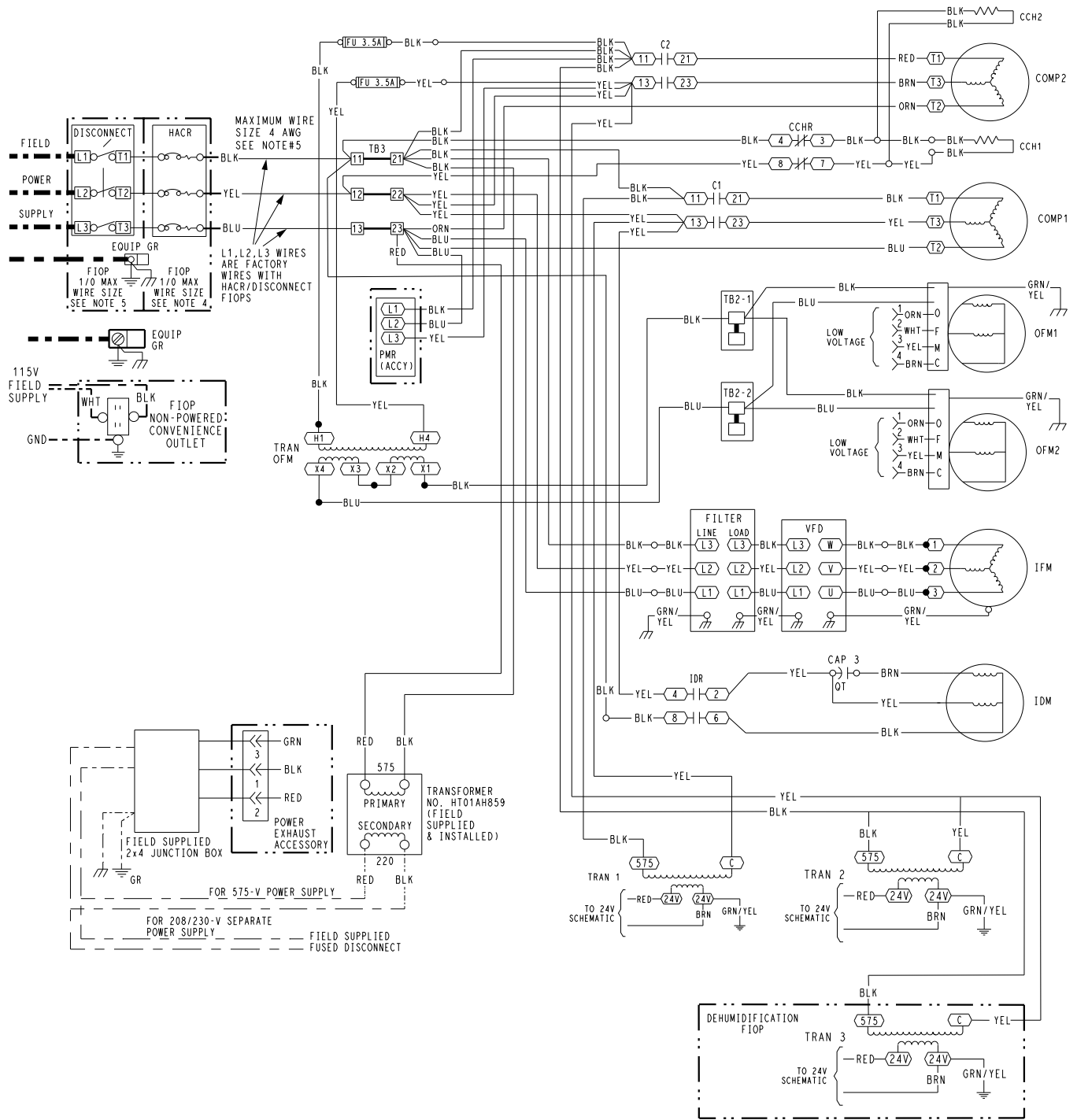

NOTES:

1. IF ANY OF THE ORIGINAL WIRE FURNISHED MUST BE REPLACED, IT MUST BE REPLACED WITH TYPE 90 C WIRE OR ITS EQUIVALENT.
2. COMPRESSOR AND FAN MOTORS ARE THERMALLY PROTECTED. THREE PHASE MOTORS ARE PROTECTED AGAINST PRIMARY SINGLE PHASING CONDITIONS.
3. TRAN IS WIRED FOR 575V UNIT.
4. USE COPPER, COPPER CLAD ALUMINUM OR ALUMINUM CONDUCTORS.
5. USE COPPER CONDUCTOR ONLY.

YAC POWER TIER3 - 6 TON 575V 3Ø PIC	
48LC500549	C

a48-9328

Fig. 31 - 48LC 07 Power Wiring, SystemVu™ Control, Diagram, 575V Units

Units With Factory-Installed Non-Fused Disconnect or HACR —

The factory-installed optional non-fused disconnect (NFD) or HACR switch is located in a weatherproof enclosure located under the main control box. The manual switch handle and shaft is shipped in the disconnect or HACR enclosure. Assemble the shaft and handle to the switch at this point. Discard the factory test leads (see Fig. 23).

Connect field power supply conductors to LINE side terminals when the switch enclosure cover is removed to attach the handle.

To field install the NFD shaft and handle:

1. Remove the unit front panel (see Fig. 2).
2. Remove (3) hex screws on the NFD enclosure - (2) on the face of the cover and (1) on the left side cover.
3. Remove the front cover of the NFD enclosure.
4. Make sure the NFD shipped from the factory is at OFF position (the arrow on the black handle knob is at OFF).
5. Insert the shaft with the cross pin on the top of the shaft in the horizontal position.
6. Measure from the tip of the shaft to the top surface of the black pointer; the measurement should be 3.75 to 3.88 in. (95 to 99 mm).
7. Tighten the locking screw to secure the shaft to the NFD.
8. Turn the handle to the OFF position with red arrow pointing at OFF.
9. Install the handle on to the painted cover horizontally with the red arrow pointing to the left.
10. Secure the handle to the painted cover with (2) screws and lock washers supplied.
11. Engaging the shaft into the handle socket, re-install (3) hex screws on the NFD enclosure.
12. Re-install the unit front panel.

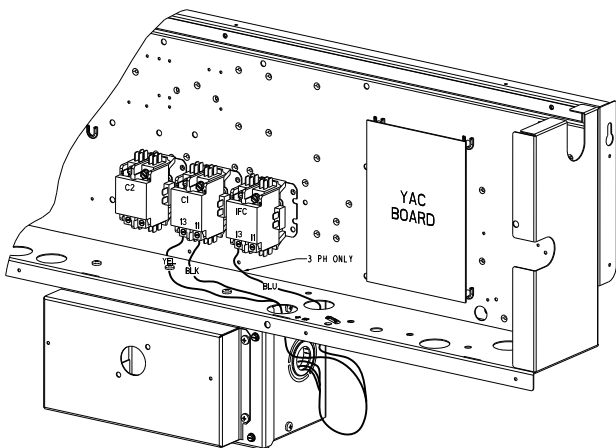

C12278

Fig. 32 - Location of Non-Fused Disconnect Enclosure

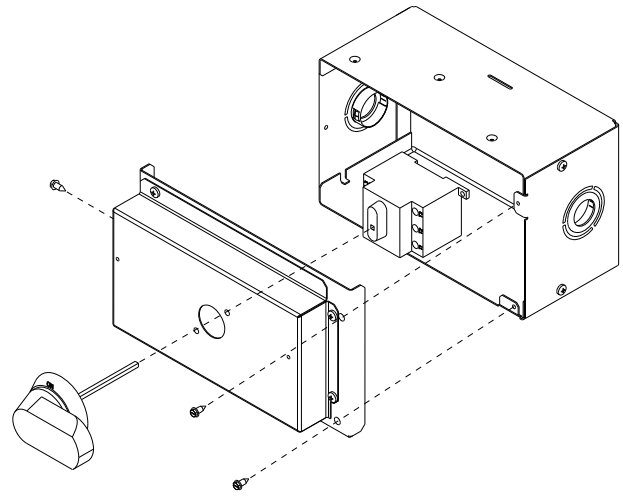

C12279

Fig. 33 - Handle and Shaft Assembly for NFD

To field install the HACR shaft and handle:

1. Remove the unit front panel (see Fig. 2).
2. Remove (3) hex screws on the HACR enclosure - (2) on the face of the cover and (1) on the left side cover.
3. Remove the front cover of the HACR enclosure.
4. Make sure the HACR shipped from the factory is at OFF position (the white arrow pointing at OFF).
5. Insert the shaft all the way with the cross pin on the top of the shaft in the horizontal position.
6. Tighten the locking screw to secure the shaft to the HACR.
7. Turn the handle to the OFF position with red arrow pointing at OFF.
8. Install the handle on to the painted cover horizontally with the red arrow pointing to the left.
9. Secure the handle to the painted cover with (2) screws and lock washers supplied.
10. Engaging the shaft into the handle socket, re-install (3) hex screws on the HACR enclosure.
11. Re-install the unit front panel.

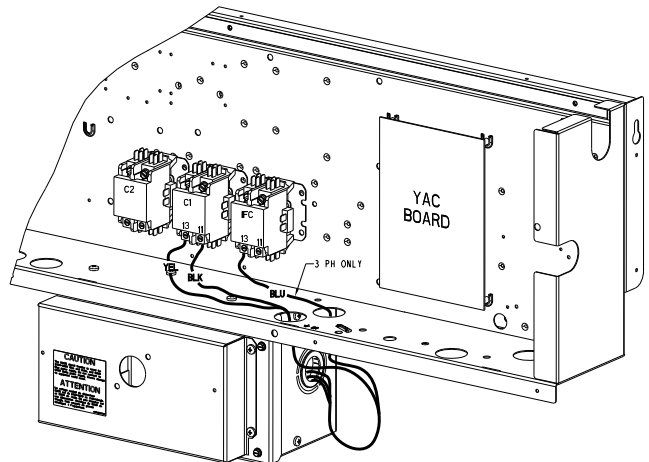

C12280

Fig. 34 - Location of HACR Enclosure

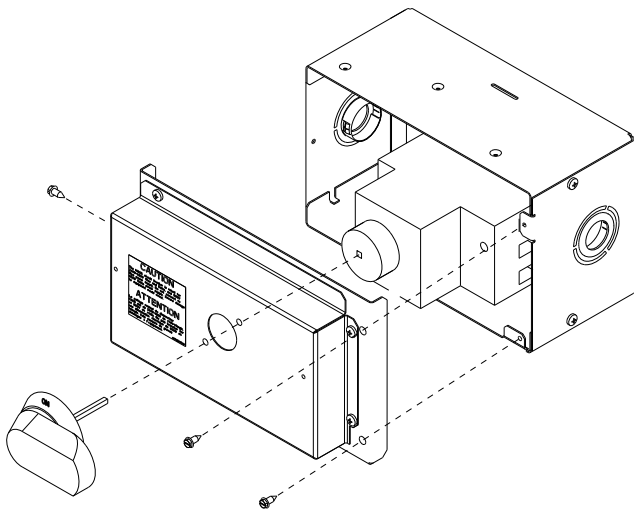

C12281

Fig. 35 - Handle and Shaft Assembly for HACR

Units Without Factory-Installed Non-Fused Disconnect or HACR —

When installing units, provide a disconnect switch per NEC (National Electrical Code) of adequate size. Disconnect sizing data is provided on the unit informative plate. Locate on unit cabinet or within sight of the unit per national or local codes. Do not cover unit informative plate if mounting the disconnect on the unit cabinet.

All Units —

All field wiring must comply with NEC and all local codes. Size wire based on MCA (Minimum Circuit Amps) on the unit informative plate. See Fig. 23 and unit label diagram for power wiring connections to the unit and equipment ground. Maximum wire size is #4 ga AWG (copper only) per pole on contactors and #2 ga AWG (copper only) per pole on optional non-fused disconnect or HACR.

Provide a ground-fault and short-circuit over-current protection device (fuse or breaker) per NEC Article 440 (or local codes). Refer to unit informative data plate for MOCP (Maximum Over-current Protection) device size.

NOTE: Units ordered with factory-installed HACR do not need an additional ground-fault and short-circuit over-current protective device unless required by local codes.

All field wiring must comply with the NEC and local requirements.

All units except 208/230-v units are factory wired for the voltage shown on the nameplate. *If the 208/230-v unit is to be connected to a 208-v power supply, the control transformer must be rewired by moving the black wire with the 1/4-in. female spade connector from the 230-v connection and moving it to the 200-v 1/4-in. male terminal on the primary side of the transformer.* Refer to unit label diagram for additional information.

Voltage to compressor terminals during operation must be within voltage range indicated on unit nameplate. See Tables 21 - 22. On 3-phase units, voltages between phases must be balanced within 2% and the current within 10%. Use the formula shown in the legend for Tables 21

and 22, Note 3 (see page 64) to determine the percent of voltage imbalance. Operation on improper line voltage or excessive phase imbalance constitutes abuse and may cause damage to electrical components. Such operation would invalidate any applicable Carrier warranty.

NOTE: Check all factory and field electrical connections for tightness.

Convenience Outlets —

⚠ WARNING

ELECTRICAL OPERATION HAZARD

Failure to follow this warning could result in personal injury or death.

Units with convenience outlet circuits may use multiple disconnects. Check convenience outlet for power status before opening unit for service. Locate its disconnect switch, if appropriate, and open it. Lock-out and tag-out this switch, if necessary.

Two types of convenience outlets are offered on 48LC models: Non-powered and unit-powered. Both types provide a 125-volt GFCI (ground-fault circuit-interrupter) duplex receptacle rated at 15-A behind a hinged waterproof access cover, located on the end panel of the unit. See Fig. 36.

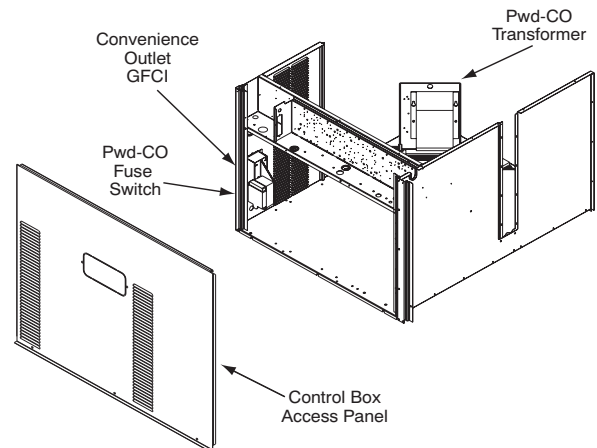

C08128

Fig. 36 - Convenience Outlet Location

Installing Weatherproof Cover: A weatherproof while-in-use cover for the factory-installed convenience outlets is now required by UL standards. This cover cannot be factory-mounted due its depth; it must be installed at unit installation. For shipment, the convenience outlet is covered with a blank cover plate.

The weatherproof cover kit is shipped in the unit's control box. The kit includes the hinged cover, a backing plate and gasket.

DISCONNECT ALL POWER TO UNIT AND CONVENIENCE OUTLET. LOCK-OUT AND TAG-OUT ALL POWER.

Remove the blank cover plate at the convenience outlet; discard the blank cover.

Loosen the two screws at the GFCI duplex outlet, until approximately 1/2-in. (13 mm) under screw heads are exposed. Press the gasket over the screw heads. Slip the backing plate over the screw heads at the keyhole slots and align with the gasket; tighten the two screws until snug (do not over-tighten).

Mount the weatherproof cover to the backing plate as shown in Fig. 37. Remove two slot fillers in the bottom of the cover to permit service tool cords to exit the cover. Check for full closing and latching.

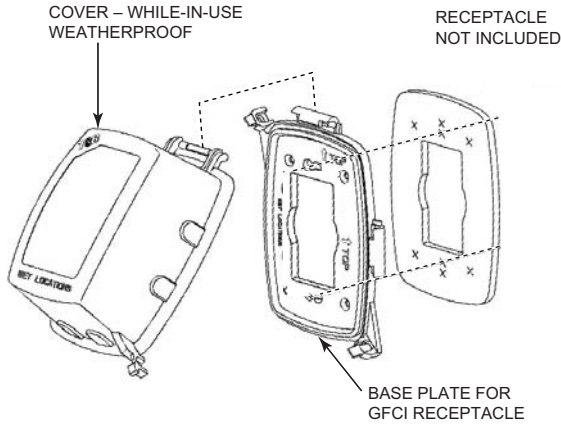

Fig. 37 - Weatherproof Cover Installation

C09022

Non-powered type: This type requires the field installation of a general-purpose 125-volt 15-A circuit powered from a source elsewhere in the building. Observe national and local codes when selecting wire size, fuse or breaker requirements and disconnect switch size and location. Route 125-v power supply conductors into the bottom of the utility box containing the duplex receptacle.

Unit-powered type: A unit-mounted transformer is factory-installed to stepdown the main power supply voltage to the unit to 115-v at the duplex receptacle. This option also includes a manual switch with fuse, located in a utility box and mounted on a bracket behind the convenience outlet; access is through the unit's control box access panel. See Fig. 36.

The primary leads to the convenience outlet transformer are not factory-connected. Selection of primary power source is a customer-option. If local codes permit, the transformer primary leads can be connected at the line-side terminals on the unit-mounted non-fused disconnect or HACR breaker switch; this will provide service power to the unit when the unit disconnect switch or HACR switch is open. Other connection methods will result in the convenience outlet circuit being de-energized when the unit disconnect or HACR switch is open. See Fig. 38.

Using unit-mounted convenience outlets: Units with unit-mounted convenience outlet circuits will often require that two disconnects be opened to de-energize all power to the unit. Treat all units as electrically energized until the convenience outlet power is also checked and de-energization is confirmed. Observe National Electrical

Code Article 210, Branch Circuits, for use of convenience outlets.

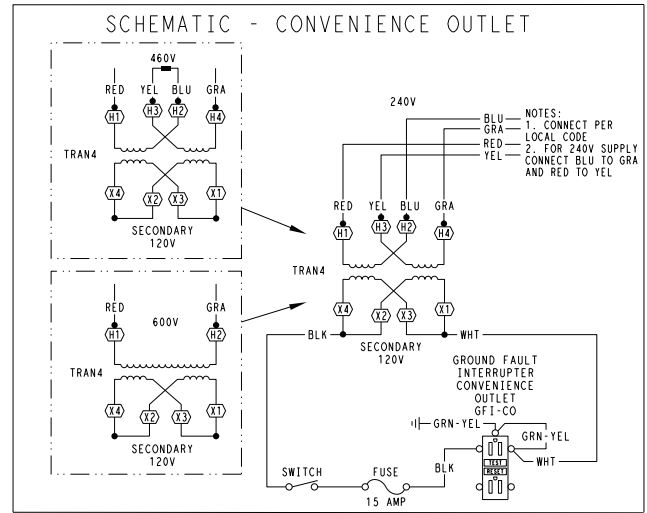

C08283

UNIT VOLTAGE	CONNECT AS	PRIMARY CONNECTIONS	TRANSFORMER TERMINALS
208, 230	240	L1: RED + YEL L2: BLU + GRA	H1 + H3 H2 + H4
460	480	L1: RED Splice BLU + YEL L2: GRA	H1 H2 + H3 H4
575	600	L1: RED L2: GRA	H1 H2

Fig. 38 - Powered Convenience Outlet Wiring

Fuse on power type: The factory fuse is a Bussman “Fusetron” T-15, non-renewable screw-in (Edison base) type plug fuse.

Duty Cycle: the unit-powered convenience outlet has a duty cycle limitation. The transformer is intended to provide power on an intermittent basis for service tools, lamps, etc; it is not intended to provide 15-amps loading for continuous duty loads (such as electric heaters for overnight use). Observe a 50% limit on circuit loading above 8-amps.

Convenience outlet usage rating:

See Fig. 39, below.

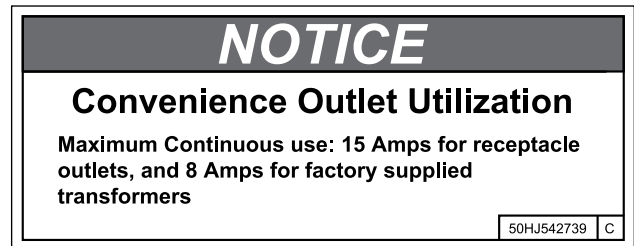

a48-9320

Fig. 39 - Convenience Outlet Utilization Notice Label

Test the GFCI receptacle by pressing the TEST button on the face of the receptacle to trip and open the receptacle. Check for proper grounding wires and power line phasing if the GFCI receptacle does not trip as required. Press the RESET button to clear the tripped condition.

HACR —

The amp rating of the HACR factory-installed option is based on the size, voltage, indoor motor and other electrical options of the unit as shipped from the factory. If field-installed accessories are added or changed in the field (i.e. power exhaust, etc.), the HACR may no longer be of the proper amp rating and therefore will need to be removed from the unit. See unit nameplate and label on factory-installed HACR for the amp rating of the HACR that was shipped with the unit from the factory. See unit nameplates for the proper fuse, HACR or maximum over-current protection device required on the unit with field-installed accessories.

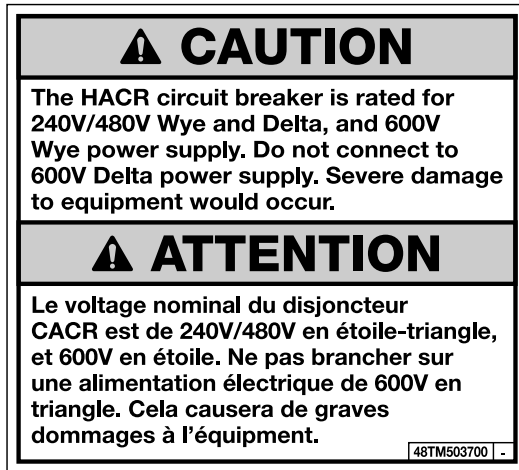

Fig. 40 - HACR Caution Label

Factory-Option Thru-Base Connections (Electrical Connections) —

This service connection kit consists of a 1/2-in. electrical bulkhead connector and a 1 1/4-in. electrical bulkhead connector, all factory-installed in the embossed (raised) section of the unit basepan in the condenser section. The 1/2-in. bulkhead connector enables the low-voltage control wires to pass through the basepan. The 1 1/4-in. electrical bulkhead connector allows the high-voltage power wires to pass through the basepan. See Fig. 15.

Check tightness of connector lock nuts before connecting electrical conduits.

Field-supplied and field-installed liquid tight conduit connectors and conduit may be attached to the connectors on the basepan. Pull correctly rated high voltage and low voltage through appropriate conduits. Connect the power conduit to the internal disconnect (if unit is so equipped) or to the external disconnect (through unit side panel). A hole must be field cut in the main control box bottom on the left side so the 24-v control connections can be made. Connect the control power conduit to the unit control box at this hole.

Units Without Thru-Base Connections —

1. Install power wiring conduit through side panel openings. Install conduit between disconnect and control box.
2. Install power lines to terminal connections as shown in Fig. 23.

Field Control Wiring —

The 48LC unit requires an external temperature control device such as a thermostat (field-supplied).

Thermostat —

Install a Carrier-approved accessory thermostat according to installation instructions included with the accessory. For complete economizer function and 3 stage compressor operation select a three-stage cooling thermostat. If a 3-stage cooling thermostat is not available use a 2-stage cooling thermostat instead, but note that this will limit cooling to just 2 stages. Locate the thermostat accessory on a solid wall in the conditioned space to sense average temperature in accordance with the thermostat installation instructions.

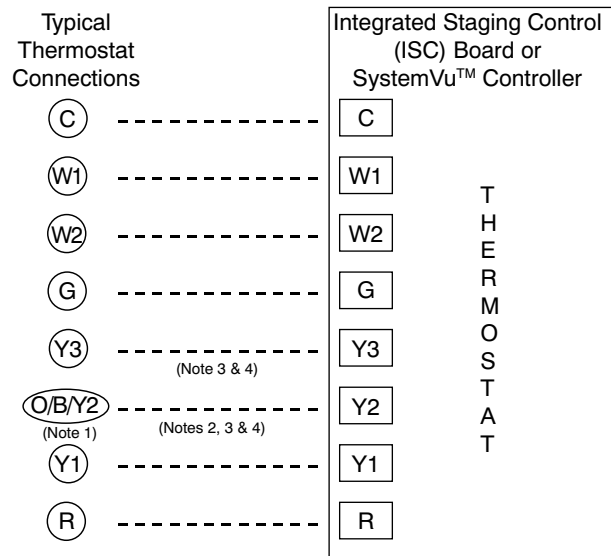

- Note 1: Typical multi-function marking. Follow manufacturer's configuration Instructions to select Y2.
- Note 2: Y2 to Y3 connection required for 2-stage cooling operation and when integrated economizer function is desired.
- Note 3: To Connect a 2-Stage Thermostat: Y2 to Y3 connection required for 2-stage cooling operation which provides low and high cooling states.
- Note 4: SystemVu controller is default configured for 3-stage cooling and 2-stage heating thermostats; it can be configured for other thermostat types.
- Field Wiring

Fig. 41 - Low-Voltage Connections

If the thermostat contains a logic circuit requiring 24-v power, use a thermostat cable or equivalent single leads of different colors with minimum of eight leads. If the thermostat does not require a 24-v source (no "C" connection required), use a thermostat cable or equivalent with minimum of seven leads. Check the thermostat installation instructions for additional features which might require additional conductors in the cable.

For wire runs up to 50 ft (15 m), use no. 18 AWG (American Wire Gage) insulated wire (35°C minimum). For 50 to 75 ft (15 to 23 m), use no. 16 AWG insulated wire (35°C minimum). For over 75 ft (23 m), use no. 14 AWG insulated wire (35°C minimum). All wire sizes larger than no. 18 AWG cannot be directly connected to the thermostat and will require a junction box and splice at the thermostat.

Unit without Thru-Base Connection Kit —

Pass the thermostat control wires through the hole provided in the corner post; then feed the wires through the raceway built into the corner post (see Fig. 42) to the control box. Pull the wires over to the terminal strip on the upper-left corner of the Controls Connection Board.

NOTE: If thru-the-bottom connections accessory is used, refer to the accessory installation instructions for information on routing power and control wiring.

Heat Anticipator Settings —

Set heat anticipator settings at 0.14 amp for the first stage and 0.14 amp for second-stage heating, when available.

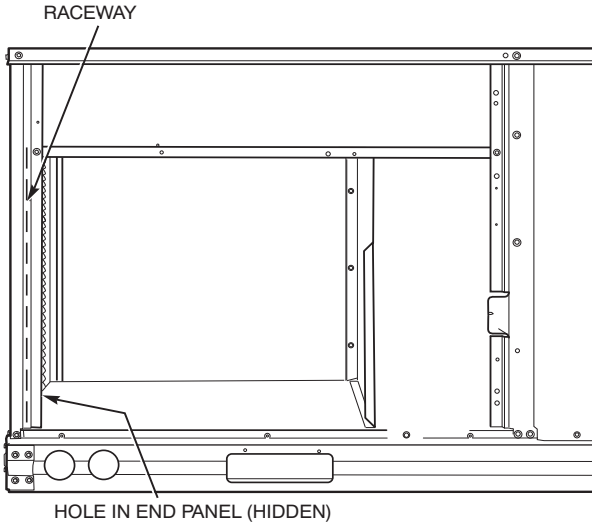

Fig. 42 - Field Control Wiring Raceway

C08027

Humidi-MiZer® System Control Connections

NOTE: It is suggested to ensure the Auto-Changeover function of an installed thermostat is enabled when used in conjunction with the Humidi-MiZer Adaptive Dehumidification system.

Humidi-MiZer System – Space RH Controller —

The Humidi-MiZer dehumidification system requires a field-supplied and installed space relative humidity control device. This device may be a separate humidistat control (contact closes on rise in space RH above control setpoint) or a combination thermostat-humidistat control device with isolated contact set for dehumidification control.

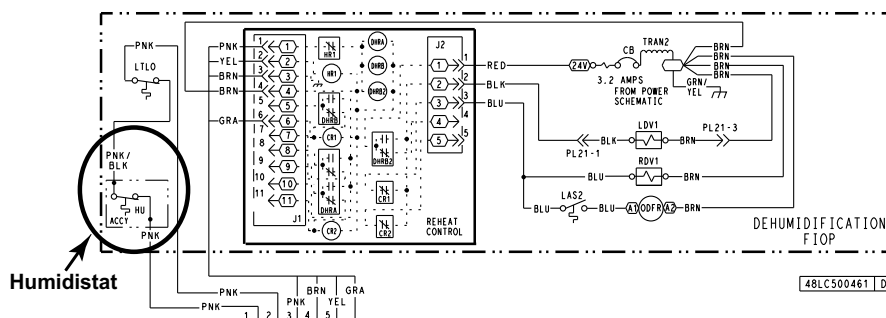

Fig. 44 - Typical Humidi-MiZer Adaptive Dehumidification System Humidistat Wiring

a48-9329

NOTE: Use of a humidistat device is not permitted on 48LC units equipped with RTU Open control; these units require use of a field-supplied RH sensor (33ZCSENSRH-02 or 33ZHCSENDRH-02, or a ZS series sensor with humidity sensing. SystemVu™ controls requires a Space Humidistat (HL38MG029) or a Wall Mount Space Humidity Sensor (33ZCSENSRH-01) or a Duct Mount Humidity Sensor (33ZCSENDRH-01).

To connect the Carrier humidistat (HL38MG029):

1. Route the humidistat 2-conductor cable (field-supplied) through the hole provided in the unit corner post.
2. Feed wires through the raceway built into the corner post (see Fig. 42) to the 24-v barrier located on the left side of the control box. The raceway provides the UL-required clearance between high-voltage and low-voltage wiring.
3. Use wire nuts to connect humidistat cable to the leads in the low-voltage wiring (as shown in Fig. 44), connecting PNK to PNK and PNK/BLK to PNK/BLK.

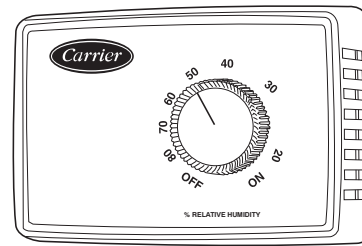

Fig. 43 - Accessory Field-Installed Humidistat

C09295

NOTE: 48LC**07 units require a 3--stage cooling thermostat device and are not compatible with Carrier's Edge® Pro thermostat.

RTU Open Controller (Factory-Installed Option)

For details on operating 48LC**07 units equipped with the factory-installed RTU Open controller option refer to *48/50LC 07-26 Factory Installed Option RTU Open Multi-Protocol Controller Controls, Start-up, Operation and Troubleshooting* manual.

SystemVu Controller (Factory-Installed Option)

For details on operating 48LC**07 units equipped with the factory-installed SystemVu control option refer to *48/50LC 04-26 Single Package Rooftop Units with SystemVu Controls Version 2.X Controls, Start-up, Operation and Troubleshooting* manual.

→

Integrated Staging Control (ISC) Board

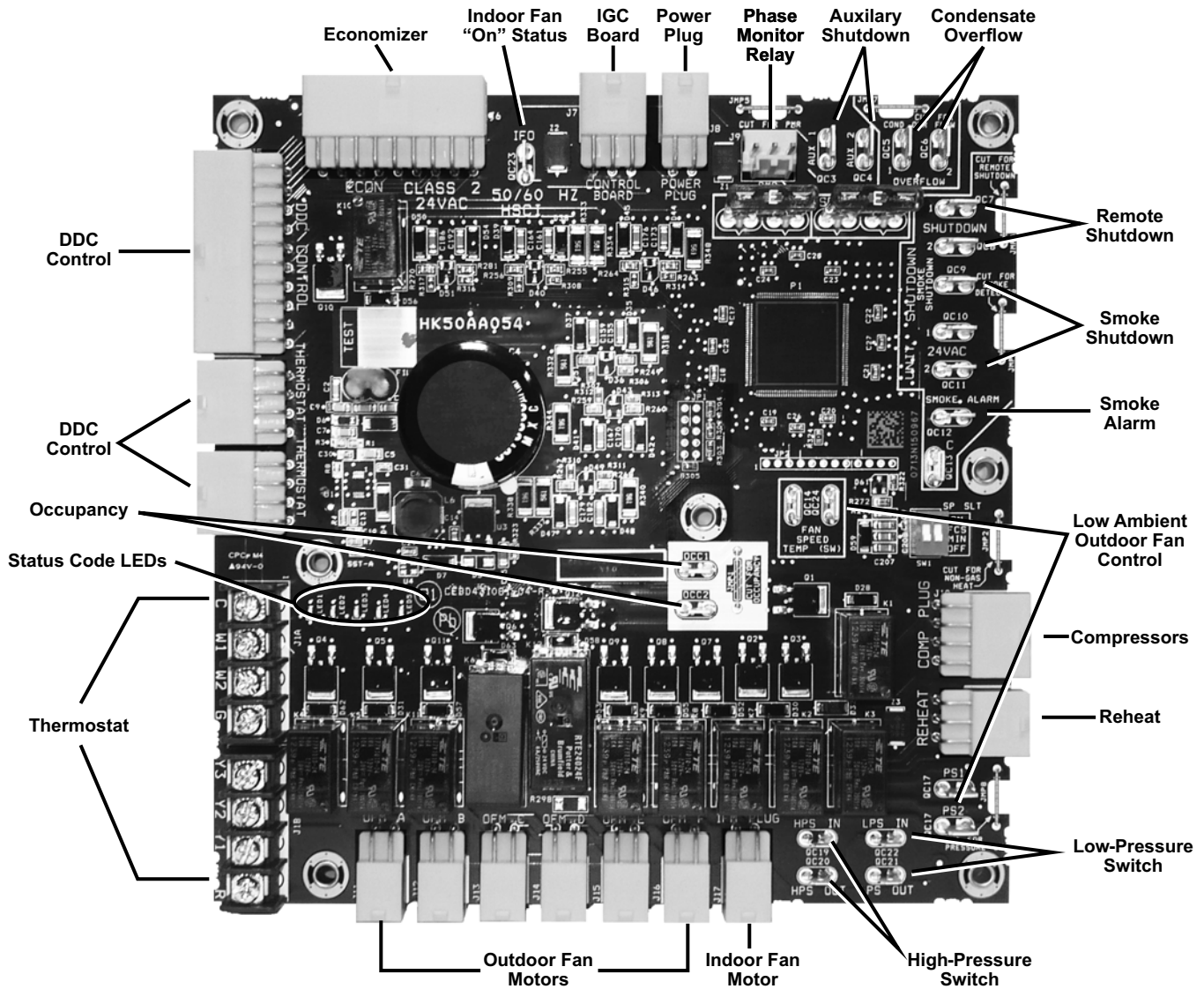

Fig. 45 - Integrated Staging Control (ISC) Board

a48-9321

ISC Board - Sequence of Operation

General —

The Carrier Integrated Staging Control (ISC) is intended for use with a standard thermostat or direct digital controls (DDC) capable of three cooling stages. After initial power to the board, a Green LED will blink with a 1 second duty cycle indicating the unit is running properly. In the event of the ISC board failing, the Green LED will be OFF or continuously ON. When the unit is not running properly, the Green LED will blink along with Red LED lights. The Red LED light configuration will indicate the type of error the board has identified. See Fig. 45 for LED locations and Table 6 for a list of the status codes.

The ISC board can be remotely shutdown by removing Jumper 4 and wiring to the Remote Shutdown terminal. The Smoke Control Module can shutdown the unit by removing Jumper 3 and wiring to the Smoke Shutdown terminal. The Smoke Alarm terminal on the ISC Board

provides a pass thru connection should a smoke alarm signal be connected. In the case of the RTU Open option, the RTU Open controller provides the signal which is passed thru the ISC board to the Smoke Alarm terminal.

The crankcase heater will run at all times except when the compressors are running. An auxiliary power supply (24Vac) available at TB-4 Terminal is provided to power auxiliary equipment. An optional Phase Monitor Relay can be wired to the PMR terminal by removing Jumper 5. An optional Condensate Flow Switch can be wired to the COFS Terminal by removing Jumper 7.

Ventilation —

In the Ventilation/Fan Mode (G on the thermostat), the indoor-fan will run at low speed and the damper will operate at minimum position.

Table 6 – Status Code Descriptions for ISC Board LEDs

ERROR#	ERROR NAME	LED INDICATION				
		LED01	LED02	LED03	LED04	LED05
1	Check Smoke Detector/PMR/AUX		RED	Blinking Green LED (Note 1)		
2	Check HPS/LPS/COFS	RED	RED			
3	Call for Y3 with no call for Y1. Check Y1 wiring.				RED	
4	Call for Y3 with no call for Y1/Y2. Check Y1 wiring.				RED	RED
5	Call for Y2 with no call for Y1. Check Y1 wiring.		RED		RED	
6	Call for W2 with no call for W1. Check W1 wiring.	RED				RED
7	Call for heat (W1/W2) and cooling (Y1/Y2/Y3). Check thermostat wiring.	RED	RED		RED	RED
8	Call for heat (W1/W2) with no IFM. Check G wiring.		RED		RED	RED
9	Call for cooling (Y1/Y2/Y3) with no G. Check G wiring	RED	RED		RED	
10	Call for heat (W1/W2) and cooling (Y1/Y2/Y3) with no G. Check thermostat and G wiring.	RED	RED			RED
11	Check ISC Board and the thermostat wiring	RED				RED
12	Call for Economizer Y1 Feedback (ECON) from economizer with no call for Y1 from thermostat. Check thermostat and economizer wiring.	RED				
13	Check ISC Board and the thermostat wiring	RED				RED
14	Check ISC Board and the thermostat wiring					RED
15	Check ISC Board and the thermostat wiring		RED			RED

- NOTES: 1. Green LED Blinking at 1Hz indicates normal operation.
2. Solid red LED indicates an error exists, see above LED configuration.

Cooling —

In the Cooling Mode, the small and large compressors will be sequenced to maintain the thermostat temperature setpoint. The chart below shows the cooling operation based on the following conditions.

INPUT	OUTPUT			
	Compressor C1	Compressor C2	Indoor Fan Speed	Outdoor Fan Speed
Thermostat				
First Stage Cooling (Y1)	On	Off	Low	Low (700 rpm)
Second Stage Cooling (Y2)	Off	On	Medium	Medium (800 rpm)
Third Stage Cooling (Y3)	On	On	High	High (1000 rpm)

The outdoor fan and VFD controlled indoor-fan will operate at low, medium and high speed. The indoor-fan speed (rpm) is factory set by the CFM and static pressure requirements for the unit installed.

Humidi-MiZer® System (Optional) —

In the Dehumidification Mode, both compressors will run and Indoor airflow will be rise to High Speed.

At subcooler reheating mode (reheat-1), during part load conditions when the room temperature and humidity are above the set point, the unit initiates the sub-cooling mode of operation; a call for cooling and dehumidification. RDV (Reheat Discharge Valve) and TWV (Three Way Valve) close; Indoor and Outdoor airflow will rise until reaching 100% of Speed.

At hot-gas-bypass reheating mode (reheat-2), when there is a call for dehumidification without a call for cooling, a portion of the hot gas from the compressor bypasses the condenser coil when RDV opens and hot gas is fed into the liquid line, TWV closes in this mode and the system provides mainly latent cooling. Indoor airflow will rise

until reaching 100% of Speed, Outdoor airflow will run at High speed as long as outdoor temperature is above 80°F (26.7°C); when operating in this mode below 80°F (26.7°C) OAT, the system outdoor fan will operate as shown in the table below based on Size:

LC Size	RPM	Number of Fans On	Number of Fans Off
07	250	2	0

Economizer (Optional) —

When the economizer is in Free Cooling Mode and a demand for cooling exists (Y1 on the thermostat), the economizer will modulate the outdoor-air damper to provide a 50°F (10°C) to 55°F (13°C) mixed-air temperature into the zone and run the indoor-fan at high speed. As mixed-air temperature fluctuates above 55°F (13°C) or below 50°F (10°C) dampers will be modulated (open or close) to bring the mixed-air temperature back within control. Upon more call for cooling (Y2 on the thermostat), the outdoor-air damper will maintain its current position, compressor C1 will run and the outdoor-fan will run at low speed. If there is further demand for cooling, the outdoor-air damper will maintain its current position, only compressor C2 will run and the outdoor-fan will run at medium speed. The VFD controlled indoor-fan will operate at high speed regardless of the cooling demand.

If the increase in cooling capacity causes the mixed-air temperature to drop below 45°F (7°C), the outdoor-air damper will return to the minimum position. If the mixed-air temperature continues to fall, the outdoor-air damper will close. Control returns to normal once the mixed-air temperature rises above 48°F (9°C). The power exhaust fans will be energized and de-energized, if installed, as the outdoor-air damper opens and closes.

In field-installed accessory CO₂ sensors are connected to the Economizer, a demand controlled ventilation strategy

will begin to operate. As the CO₂ level in the zone increases above the CO₂ set-point, the minimum position of the damper will be increased proportionally. As the CO₂ level decreases because of the increase of fresh air, the outdoor-air damper will be proportionally closed. For economizer operation, there must be a thermostat call for the fan (G). If the unit is occupied and the fan is on, the damper will operate at minimum position. Otherwise, the damper will be closed.

Low Ambient Cooling Operation down to 40°F (4°C) —

In Low Ambient RTU conditions when the temperature is between 55°F (13°C) and 40°F (4°C), the Low Ambient Switch (LAS) will be active and the outdoor fans will run to the pre-set factory outdoor-fan speed. When the temperature is greater than 65°F (18°C), the Low Ambient Switch will deactivate and the outdoor fans will run in the standard cooling mode. If the Outdoor Fan Select Switch (see Fig. 46) is in the ON position, the outdoor fans will run in the Fan Cycle Speed Mode (FCS) set to 250 rpm. If the Outdoor Fan Select Switch is in the OFF position, the outdoor fans will run in the Minimum Fan Speed Mode (MIN) set to 160 rpm regardless of the cooling demand.

LC Size 07 units have a SPST normally open Low Ambient Switch wired across the TS and OF terminal and a jumper placed across the PS terminal (see Fig. 47). When the LAS is active, the switch will close making contact to the OF terminal. This is done for units that require all outdoor fans to run at the same pre-set factory Low Ambient Speed.

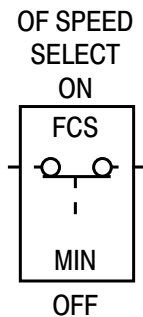

Fig. 46 - Outdoor Fan Speed Select Switch a48-9341

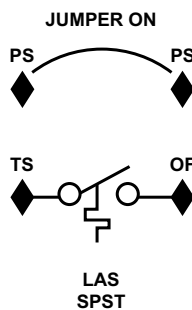

Fig. 47 - Schematic of SPST Low Ambient Switch C13328

The Low Ambient Temperature Outdoor Fan Control Table (below) shows the operation of the outdoor fan for size 07 units.

Table 7 – Low Ambient Temperature Outdoor Fan Control

LC Size	No. of Fans On	No. of Fans Off	Switch	Outdoor Fan Select Switch	RPM
07	2	0	SPST	Up	250

Heating —

In the Heating Mode (W1 and G on the thermostat), the ISC board sends power to W on the IGC board. Assuming the unit is controlled through a room thermostat set for fan auto, the indoor-fan motor will energize and the outdoor-air dampers will open to their minimum position. The ISC board upon seeing W1 and G ON will turn the indoor fan to high speed.

The IGC board starts its gas ignition process. A check is made to ensure that the rollout switch and limit switch are closed. If the check was successful, the induced draft motor is energized, and when its speed is satisfactory, as proven by the flue gas pressure switch, the ignition activation period begins. The burners will ignite within 5 seconds. If the burners do not light, there is a 22-second delay before another 5-second attempt. This sequence is repeated for 15 minutes or until the burners light. If, after the 15 minutes, the burners still have not lit, heating is locked out. To reset the control, break 24VAC power to the thermostat.

When gas ignition occurs, the IGC board will continue to monitor the condition of the rollout switch, the limit switches, the flue gas pressure switch, as well as the flame sensor.

When W1 is turned OFF, the IGC board turns off the gas valve. The IGC board has a delay time before it turns IFO=OFF. At this time, the ISC board sees W1=OFF and IFO=ON. The ISC will keep the indoor fan ON high speed. Once the IGC board delay times out, the ISC board will see W1=OFF and IFO=OFF, which then turns the indoor fan OFF.

If the call for W1 lasted less than 1 minute, the heating cycle will not terminate until 1 minute after W1 became active. If the unit is controlled through a room thermostat set for fan auto, the indoor fan motor will continue to operate for an additional 45 seconds then stop. If the over temperature limit opens after the indoor motor is stopped, but within 10 minutes of W1 becoming inactive, on the next cycle the time will be extended by 15 seconds. The maximum delay is 3 minutes. Once modified, the fan OFF delay will not change back to 45 seconds unless power is reset to the control. A LED indicator is provided on the IGC to monitor operation.

When additional heat is required, W2 closes and initiates power to the second stage of the main gas valve. When the thermostat is satisfied, the gas valve closes, interrupting the flow of gas to the main burners.

EconoMi\$er® X (Factory-Installed Option)

EconoMi\$er X is an economizer system which is available for 48LC 07 units.

The factory-installed option consists of:

- Either a Low leak or a Standard leak economizer damper assembly
- Direct-drive damper actuator with local equipment bus communications
- W7220 economizer controller with keypad and display
- Supply Air Temperature sensor (20K ohm)
- Outdoor changeover condition sensor (either 20K ohm dry-bulb or enthalpy sensor)

Unit Installation —

All damper hardware and standard economizer control components except the enthalpy sensor are factory-mounted in their operating location. Complete the unit installation by relocating the enthalpy sensor (when provided; see below), then assembling and mounting the unit's outside air hood. Refer to the base unit's installation instruction manual for directions on locating the hood parts package and assembling the hood with filters.

Enthalpy Sensor Relocation —

See Fig. 56 for view of the enthalpy sensor. Locate the enthalpy sensor on the side of the economizer housing; remove mounting screws and save screws. Confirm the DIP switches are set at OFF, OFF, OFF (see Table 15). Move the enthalpy sensor to the front face of the economizer housing and mount per label.

W7220 Economizer Controller

The economizer controller used on electro-mechanical units is the Honeywell W7220.

The W7220 provides typical economizer functions, including:

- Management of outside air damper for base unit Occupied (damper open and modulating) and unit OFF or Unoccupied status (damper closed)
- Free-cooling using all outside air when outdoor conditions permit Integrated cooling operation using outside air and mechanical cooling when required
- Demand Controlled Ventilation (DCV) for modulating ventilation airflow according to space CO₂ level (requires factory-option or field-installed CO₂ sensor)

The W7220 control also includes a new capability that will adjust the damper control points during DCV or minimum ventilation operation as the indoor fan speed is changed. This control function ensures that required space ventilation airflow quantities are maintained during reduced fan speed operation.

Additional control capabilities include automatic detection of new sensors and detection of sensor failure or loss of communication.

The W7220 control module includes an integral user interface with keypad and LCD display that permits direct input of setpoint values and configurations and display of status and alarms.

The W7220 controller is located in the RTU base unit's Control Box. See the Installation Instructions for this base unit for the location of the Control Box access panel.

User Interface —

The user interface consists of a 2-line LCD display and a 4-button keypad on the front of the economizer controller.

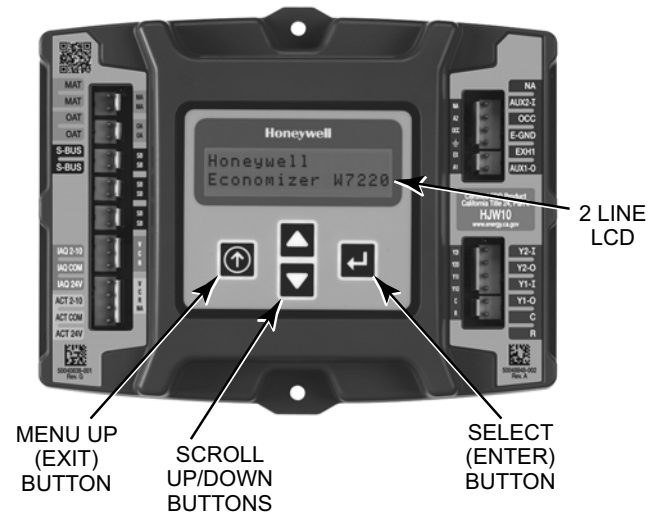

Fig. 48 - W7220 Controller

C14206

Keypad

The four navigation buttons (see Fig. 48) are used to scroll through the menus and menu items, select menu items, and to change parameter and configuration settings.

Using the Keypad with Menus

To use the keypad when working with menus:

- Press the ▲ (Up arrow) button to move to the previous menu.
- Press the ▼ (Down arrow) button to move to the next menu.
- Press the ↵ (Enter) button to display the first item in the currently displayed menu.
- Press the ⤴ (Menu Up/Exit) button to exit a menu's item and return to the list of menus.

The Menus in display order are:

- STATUS
- SETPOINTS
- SYSTEM SETUP
- ADVANCED SETUP
- CHECKOUT
- ALARMS

Using the Keypad with Settings and Parameters

To use the keypad when working with Setpoints, System and Advanced Settings, Checkout tests and Alarms:

1. Navigate to the desired menu.
 2. Press the \leftarrow (Enter) button to display the first item in the currently displayed menu.
 3. Use the \blacktriangle and \blacktriangledown buttons to scroll to the desired parameter.
 4. Press the \leftarrow (Enter) button to display the value of the currently displayed item.
 5. Press the \blacktriangle button to increase (change) the displayed parameter value.
 6. Press the \blacktriangledown button to decrease (change) the displayed parameter value.
- NOTE:** When values are displayed, pressing and holding the \blacktriangle or \blacktriangledown button causes the display to automatically increment.
7. Press the \leftarrow (Enter) button to accept the displayed value and store it in nonvolatile RAM.
 8. "CHANGE STORED" displays.

9. Press the \leftarrow (Enter) button to return to the current menu parameter.
10. Press the \oplus (Menu Up/Exit) button to return to the previous menu.

Menu Structure

IMPORTANT: Table 8 illustrates the complete hierarchy. Your menu parameters may be different depending on your configuration. For example if you do not have a DCV (CO₂) sensor, then none of the DCV parameters appear.

The menu hierarchy has been modified to reflect controller configuration for 2-speed indoor fan application in the Staged Air Volume option.

NOTE: Some parameters in the menus use the letters MA or MAT, indicating a mixed air temperature sensor location before the cooling coil. This unit application has the control sensor located after the cooling coil, in the fan section, where it is designated as (Cooling) Supply Air Temperature or SAT sensor.

Table 8 – Menu Structure*

Menu	Parameter	Parameter Default Value	Parameter Range and Increment †	EXPANDED PARAMETER NAME Notes
STATUS	ECON AVAIL	NO	YES/NO	ECONOMIZING AVAILABLE YES = economizing available; the system can use outside air for free cooling when required
	ECONOMIZING	NO	YES/NO	ECONOMIZING ACTIVE YES = Outside air being used for Cooling Stage 1. NO = Economizing not active
	OCCUPIED	NO	YES/NO	OCCUPIED YES = OCC signal received from space thermostat or unitary controller. YES = 24 Vac on terminal OCC. NO = 0 Vac on terminal OCC.
	HEAT PUMP	n/a **	COOL HEAT	HEAT PUMP MODE (Not available on 2-Speed configuration)
	COOL Y1 –IN	OFF	ON/OFF	FIRST STAGE COOLING DEMAND (Y1–IN) Y1–I signal from space thermostat or unitary controller for Cooling Stage 1. ON = 24 Vac on terminal Y1–I OFF = 0 Vac on terminal Y1–I
	COOL Y1 –OUT	OFF	ON/OFF	FIRST STAGE COOLING RELAY OUTPUT ON = 24 Vac on terminal Y1–O; Stage 1 mechanical cooling called on OFF = 0 Vac on terminal Y1–O; no mechanical cooling
	COOL Y2–IN	OFF	ON/OFF	SECOND STAGE COOLING DEMAND (Y2–IN) Y2–I signal from space thermostat or unitary controller for Cooling Stage 2. ON = 24 Vac on terminal Y2–I OFF = 0 Vac on terminal Y2–I
	COOL Y2–OUT	OFF	ON/OFF	SECOND STAGE COOLING RELAY OUTPUT ON = 24 Vac on terminal Y2–O; Stage 2 mechanical cooling called on OFF = 0 Vac on terminal Y2–O; no Stage 2 mechanical cooling
	MA TEMP	nn°F (or °C)	0 to 140°F (–18 to 60°C)	SUPPLY AIR TEMPERATURE, Cooling Mode Displays value of measured mixed/cooled air from SAT sensor in fan section. Displays --- if not connected, short or out-of-range. See Menu Note 2
	DA TEMP	nn°F (or °C)	0 to 140°F (–18 to 60°C)	DISCHARGE AIR TEMPERATURE, after Heating section (Accessory sensor required) Displays when Discharge Air sensor is connected and displays measured discharge temperature. Displays --- if sensor sends invalid value, if not connected, short or out-of-range.
	OA TEMP	nn°F (or °C)	–40 to 140°F (–40 to 60°C)	OUTSIDE AIR TEMPERATURE Displays measured value of outdoor air temperature. Displays --- if sensor sends invalid value, if not connected, short or out-of-range.
	OA HUM	nn%	0 to 100%	OUTSIDE AIR RELATIVE HUMIDITY Displays measured value of outdoor humidity from OA enthalpy sensor.

Table 8 - Menu Structure * (cont)

Menu	Parameter	Parameter Default Value	Parameter Range and Increment †	EXPANDED PARAMETER NAME Notes
STATUS (cont)	RA TEMP	nn°F (or °C)	0 to 140°F (-18 to 60°C)	RETURN AIR TEMPERATURE (Accessory sensor required) Displays measured value of return air temperature from RAT sensor.
	RA HUM	nn%	0 to 100%	RETURN AIR RELATIVE HUMIDITY (Accessory enthalpy sensor required) Displays measured value of return air humidity from RA sensor.
	IN CO2	___ppm	0 to 2000 ppm	SPACE/RETURN AIR CO2 (CO ₂ sensor required, accessory or factory option) Displays value of measured CO ₂ from CO ₂ sensor. Invalid if not connected, short or out-of-range
	DCV STATUS	n/a	ON/OFF	DEMAND CONTROLLED VENTILATION STATUS (CO ₂ sensor required, accessory or factory option) Displays ON if IN CO ₂ value above setpoint DCV SET and OFF if below setpoint DCV SET.
	DAMPER OUT	2.0V	2.0 to 10.0V	Displays voltage output to the damper actuator. 0% = OSA Damper fully closed 100% = OSA Damper full open
	ACT POS	nn%	0 to 100%	Displays actual position of outdoor air damper actuator 2.0V = OSA Damper fully-closed 10.0V = OSA Damper full open
	ACT COUNT	n/a	1 to 65535	Displays number of times actuator has cycled. 1 Cycle equals accrued 180° of actuator movement in any direction
	ACTUATOR	n/a	OK/Alarm (on Alarm menu)	Displays Error if voltage or torque is below actuator range
	EXH1 OUT	OFF	ON/OFF	EXHAUST STAGE 1 RELAY OUTPUT Output of EXH1 terminal: ON = relay closed OFF = relay open
	EXH2 OUT	OFF	ON/OFF	EXHAUST STAGE 2 RELAY OUTPUT Output of AUX terminal; displays only if AUX = EXH2 ON = relay closed OFF = relay open
	MECH COOL ON	0	0, 1, or 2	Displays stage of mechanical cooling that is active.
	FAN SPEED	n/a	LOW or HIGH	SUPPLY FAN SPEED Displays speed setting of fan on a 2-speed fan unit.
	W (HEAT ON)	n/a	ON/OFF	HEAT DEMAND STATUS Displays status of heat demand on a 2-speed fan unit.

Table 8 - Menu Structure* (cont)

Menu	Parameter	Parameter Default Value	Parameter Range and Increment †	EXPANDED PARAMETER NAME Notes
SETPOINTS	MAT SET	53°F (12°C)	38 to 65°F; (3 to 18°C) increment by 1	SUPPLY AIR SETPOINT Setpoint determines where the economizer will modulate the OA damper to maintain the mixed air temperature. See Menu Note 2.
	LOW T LOCK	32°F (0°C)	-45 to 80°F; (-43 to 27°C) increment by 1	COMPRESSOR LOW TEMPERATURE LOCKOUT Setpoint determines outdoor temperature when the mechanical cooling cannot be turned on.
	DRYBLB SET	63°F (17°C)	48 to 80°F (9 to 27°C) increment by 1	OA DRY BULB TEMPERATURE CHANGEOVER SETPOINT Setpoint determines where the economizer will assume outdoor air temperature is good for free cooling; e.g.: at 63°F (17°C), unit will economize at 62°F (16.7°C) and below and not economize at 64°F (17.8°C) and above. There is a 2°F (1.1°C) deadband. See Menu Note 3
	ENTH CURVE	ES3	ES1, ES2, ES3, ES4, or ES5	ENTHALPY CHANGEOVER CURVE (Requires enthalpy sensor option) Enthalpy boundary "curves" for economizing using single enthalpy.
	DCV SET	1100ppm	500 to 2000 ppm; increment by 100	DEMAND CONTROLLED VENTILATION SETPOINT Displays only if CO ₂ sensor is connected. Setpoint for Demand Controlled Ventilation of space. Above the setpoint, the OA dampers will modulate open to bring in additional OA to maintain a space ppm level below the setpoint.
	MIN POS L	6.0 V	2 to 10 Vdc	VENTILATION MINIMUM POSITION AT LOW SPEED Displays ONLY if a CO ₂ sensor is NOT connected.
	MIN POS H	4.4 V	2 to 10 Vdc	VENTILATION MINIMUM POSITION AT HIGH SPEED Displays ONLY if a CO ₂ sensor is NOT connected.
	VENTMAX L	6.0 V	2 to 10 Vdc	DCV MAXIMUM DAMPER POSITION AT LOW SPEED (Requires CO ₂ sensor connected)
	VENTMAX H	4.4 V	2 to 10 Vdc	DCV MAXIMUM DAMPER POSITION AT HIGH SPEED (Requires CO ₂ sensor connected)
	VENTMIN L	3.7 V	2 to 10 Vdc	DCV MINIMUM DAMPER POSITION AT LOW SPEED (Requires CO ₂ sensor connected)
	VENTMIN H	2.8 V	2 to 10 Vdc	DCV MINIMUM DAMPER POSITION AT HIGH SPEED (Requires CO ₂ sensor connected)
	EXH1 L SET	65%	0 to 100%; Increment by 1	EXHAUST FAN STAGE 1 SETPOINT AT LOW SPEED Setpoint for OA damper position when exhaust fan1 is powered by the economizer
	EXH1 H SET	50%	0 to 100%; Increment by 1	EXHAUST FAN STAGE 1 SETPOINT AT HIGH SPEED Setpoint for OA damper position when exhaust fan1 is powered by the economizer
	EXH2 L SET	80%	0 to 100%; Increment by 1	EXHAUST FAN STAGE 2 SETPOINT AT LOW SPEED Setpoint for OA damper position when exhaust fan1 is powered by the economizer. Only used when AUX1-O is set to EHX2.
EXH2 H SET	75%	0 to 100%; Increment by 1	EXHAUST FAN STAGE 2 SETPOINT AT HIGH SPEED Setpoint for OA damper position when exhaust fan1 is powered by the economizer. Only used when AUX1-O is set to EHX2.	

Table 8 - Menu Structure* (cont)

Menu	Parameter	Parameter Default Value	Parameter Range and Increment †	EXPANDED PARAMETER NAME Notes
SYSTEM SETUP	INSTALL	01/01/10		Display order = MM/DD/YY Setting order = DD, MM, then YY.
	UNITS DEG	°F	°F or °C	Sets economizer controller in degrees Fahrenheit or Celsius.
	EQUIPMENT	CONV	Conventional or HP	CONV = conventional; HP O/B = Enable Heat Pump mode. Not available with 2–speed See Menu Note 4
	AUX2 I	W	W required for 2–speed mode	W = Informs controller that system is in heating mode. SD = Enables configuration of shutdown (not available on 2–Speed) See Menu Note 4
	FAN TYPE	2speed	2speed required	Sets the economizer controller for operation of 1 speed or 2 speed indoor fan system. See Menu Note 4.
	FAN CFM	5000cfm	100 to 15000 cfm; increment by 100	UNIT DESIGN AIRFLOW (CFM) Enter ONLY of using DCVCAL ENA = AUTO The value is found in the Project Submittal documents for the specific RTU.
	AUX OUT	NONE	NONE EXH2 SYS	Select OUTPUT for AUX1 O relay NONE = not configured (output is not used) EXH2 = second damper position relay closure for second exhaust fan SYS = use output as an alarm signal
	OCC	INPUT	INPUT or ALWAYS	OCCUPIED MODE BY EXTERNAL SIGNAL When using a setback thermostat with occupancy out (24 Vac), the 24 Vac is input to the OCC terminal. RTU control circuit provides 24–Vac to OCC through OCCUPIED terminals on Integrated Staging Control. Board
	FACTORY DEFAULT	NO	NO or YES	Resets all set points to factory defaults when set to YES. LCD will briefly flash YES and change to NO but all parameters will change to the factory default values. RECHECK AUX2 I and FANTYPE for required 2–speed values.
ADVANCED SETUP	MA LO SET	45°F (7°C)	35 to 55°F; (2 to 12°C) Incremented by 1°	SUPPLY AIR TEMPERATURE LOW LIMIT Temperature to achieve Freeze Protection (close damper and alarm if temperature falls below setup value)
	FREEZE POS	CLO	CLO or MIN	FREEZE PROTECTION DAMPER POSITION Damper position when freeze protection is active CLO = closed MIN = MIN POS or VENTMAX
	CO2 ZERO	0ppm	0 to 500 ppm: Increment by 10	CO ₂ ppm level to match CO ₂ Sensor start level.
	CO2 SPAN	2000ppm	1000 to 3000 ppm; Increment by 50	CO ₂ ppm span to match CO ₂ sensor.
	STG3 DLY	2.0h	0 min, 5 min, 15 min, then 15 min intervals. Up to 4 h or OFF	COOLING STAGE 3 DELAY Delay after stage 2 for cool has been active. Turns on 2 nd stage of cooling when economizer is 1 st stage and mechanical cooling is 2 nd
	SD DMPR POS	CLO	CLO or OPN	Function NOT AVAILABLE with 2–speed mode
	DCVCAL ENA	MAN	MAN (manual)	Turns on the DCV automatic control of the dampers. Resets ventilation.
	MATTCAL	0.0°F (or C)	+/-2.5°F (+/-1.4°C)	SUPPLY AIR TEMPERATURE CALIBRATION Allows for the operator to adjust for an out of calibration supply air temperature (SAT) sensor
	OA T CAL	1.0°F (or C)	+/-2.5°F (+/-1.4°C)	OUTSIDE AIR TEMPERATURE CALIBRATION Allows for the operator to adjust for an out of calibration outside air temperature (OAT) sensor
	OA H CAL	0% RH	+/-10% RH	OUTSIDE AIR HUMIDITY CALIBRATION Allows for the operator to adjust for an out of outside air enthalpy sensor
	RA T CAL	2.0°F (or C)	+/-2.5°F (+/-1.4°C)	RETURN AIR TEMPERATURE CALIBRATION Allows for the operator to adjust for an out of calibration return air temperature (RA) sensor
	RA H CAL	0% RH	+/-10% RH	RETURN AIR HUMIDITY CALIBRATION Allows for the operator to adjust for an out of calibration return air enthalpy sensor
	DA T CAL	0.0°F (or C)	+/-2.5°F (+/-1.4°C)	DISCHARGE AIR TEMPERATURE CALIBRATION Allows for the operator to adjust for an out of calibration discharge air temperature (DAT) sensor
	2SP FAN DELAY	5 Minutes	0 to 20 minutes in 1 minute increments	TIME DELAY ON 2 nd STAGE ECONOMIZING While in the Economizing mode, this is the delay between thermostat Y2 call and Y1–O output to mechanical cooling stage, to allow high speed fan operation to attempt to cool space first.

Table 8 - Menu Structure* (cont)

Menu	Parameter	Parameter Default Value	Parameter Range and Increment †	EXPANDED PARAMETER NAME Notes
CHECKOUT	DAMPER VMIN .HS	n/a	n/a	Positions OA damper to VMIN High Speed position
	DAMPER VMAX .HS	n/a	n/a	Positions OA damper to VMAX High Speed position
	DAMPER OPEN	n/a	n/a	Positions OA damper to the full open position.
	DAMPER CLOSE	n/a	n/a	Positions damper to the fully closed position
	CONNECT Y1 –O	n/a	n/a	Closes the Y1 –O relay (Y1 –O)
	CONNECT Y2 –O	n/a	n/a	Closes the Y2 –O relay (Y2 –O)
	CONNECT AUX1O	n/a	n/a	Energizes the AUX1O output. If Aux setting is: <ul style="list-style-type: none"> • NONE – not action taken • ERV – 24 Vac out. Turns on or signals an ERV that the conditions are not good for economizing but are good for ERV operation. †† • SYS – 24 Vac out. Issues a system alarm
ALARMS()				Alarms display only when they are active. The menu title “ALARMS()” includes the number of active alarms in parenthesis ().
	MA T SENS ERR	n/a	n/a	SUPPLY AIR TEMPERATURE SENSOR ERROR
	CO2 SENS ERR	n/a	n/a	CO2 SENSOR ERROR
	OA T SENS ERR	n/a	n/a	OUTSIDE AIR TEMPERATURE SENSOR ERROR OAT sensor connected at input terminals OAT
	OA SYLK SENS ERR	n/a	n/a	OUTSIDE AIR TEMPERATURE SENSOR ERROR OAT sensor connected on S– bus
	DA T SENS ERR	n/a	n/a	DISCHARGE AIR TEMPERATURE SENSOR ERROR
	SYS ALARM	n/a	n/a	When AUX is set to SYS and there is any alarm (e.g., failed sensors, etc.), the AUX terminal has 24 Vac out.
	ACT UNDER V	n/a	n/a	ACTUATOR VOLTAGE LOW Voltage received at actuator is below expected range
	ACT OVER V	n/a	n/a	ACTUATOR VOLTAGE HIGH Voltage received at actuator is above expected range
	ACT STALLED	n/a	n/a	ACTUATOR STALLED Actuator stopped before reaching commanded position

* Table 8 illustrates the complete hierarchy, your menu parameters may be different depending on your configuration. For example if you do not have a DCV (CO₂) sensor, then none of the DCV parameters appear.

† When values are displayed, pressing and holding the ▲ or ▼ button causes the display to automatically increment.

** n/a = not applicable

†† ERV Operation: When in Cooling mode AND the conditions are NOT OK for economizing – the ERV terminal will be energized. In the Heating mode the ERV terminal will be energized when the OA is below the ERV OAT setpoint in the setpoint menu.

Menu Notes

1. **STATUS** -> **OCCUPIED** – The factory-standard Occupancy signal originates with a thermostat or other controller call for indoor fan operation at ISC terminal G. This signal passes through the Integrated Staging Control Board’s OCCUPIED jumper JMP1 to the ECONO connector and to the W7220’s OCC input terminal. An external timeclock or relay is required to implement an Occupancy schedule on the economizer damper position.
2. **STATUS** -> **MA TEMP, SETPOINTS** -> **MAT SET** – The W7220 menu parameters and labels include designations MA, MAT and Mixed Air for the economizer cooling control sensor. On these rooftop units, the economizer control sensor is located downstream of the evaporator/indoor coil in the supply fan section where this sensor is designated as Supply Air Temperature (SAT) sensor.
3. **SETPOINTS** -> **DRYBLB SET** – This point is not displayed if a Return Air (differential) temperature sensor or an Outdoor Air enthalpy sensor is connected.
4. **SYSTEM SETUP** parameters must be configured as noted for 2-Speed unit operation:
EQUIPMENT = CONV
AUX2 I = W
FAN TYPE = 2SPEED

Connections and Applications

W7220 Economizer Module Wiring —

Use Fig. 49 and Tables 9 and 10 to locate the wiring terminals for the Economizer module.

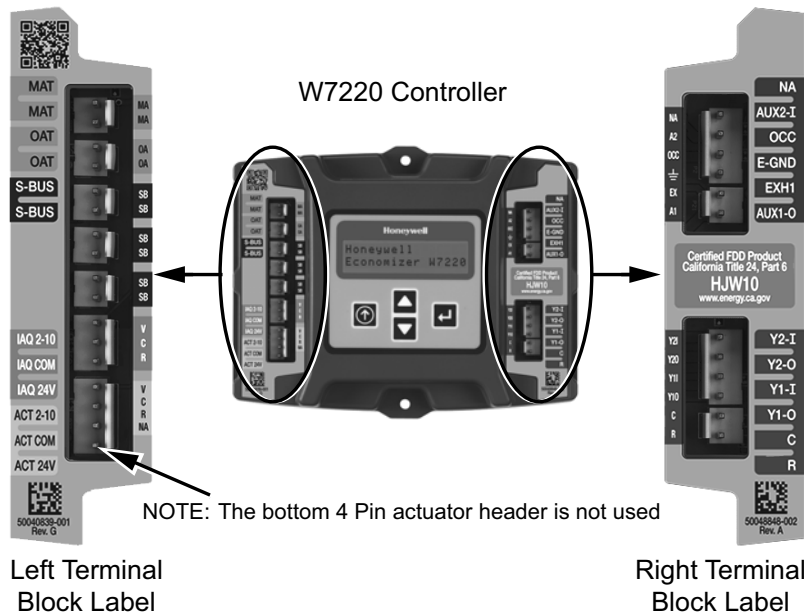

Fig. 49 - W7220 Economizer Module Terminal Connection Labels

C14156

Table 9 – Economizer Module - Left Hand Terminal Blocks

Label	Type	Description
Top Left Terminal Block		
MAT MAT	20k NTC and COM	Supply Air Temperature Sensor (polarity insensitive connection)
OAT OAT	20k NTC and COM	Outdoor Air Temperature Sensor (polarity insensitive connection)
S-BUS S-BUS	S-Bus (Sylk Bus)	Enthalpy Control Sensor (polarity insensitive connection)
Bottom Left Terminal Block		
IAQ 2-10	2-10 Vdc	Air Quality Sensor Input (e.g. CO ₂ sensor)
IAQ COM	COM	Air Quality Sensor Common
IAQ 24V	24 Vac	Air Quality Sensor 24 Vac Source
ACT 2-10	2-10 Vdc	Damper Actuator Output (2-10 Vdc)
ACT COM	COM	Damper Actuator Output Common
ACT 24V	24 Vac	Damper Actuator 24 Vac Source

Table 10 – Economizer Module - Right Hand Terminal Blocks

Label	Type	Description
Top Right Terminal Block		
N/A	n/a	The first terminal is not used
AUX2-I	24 Vac IN	Input from Thermostat W1 indicating base unit is in Heat mode, damper controls to High Fan Speed setpoints
OCC	24 Vac IN	Occupied / Unoccupied Input
E-GND	E-GND	Earth Ground – System Required
EXH1	24 Vac OUT	Exhaust Fan 1 Output
AUX1-O	24 Vac OUT	Programmable: Exhaust fan 2 output or ERV or System Alarm output
Bottom Right Terminal Block		
Y2-I	24 Vac IN	Y2 in – Cooling Stage 2 Input from space thermostat
Y2-O	24 Vac OUT	Y2 out – Cooling Stage 2 Output to stage 2 mechanical cooling
Y1-I	24 Vac IN	Y1 in – Cooling Stage 2 Input from space thermostat
Y1-O	24 Vac OUT	Y1 out – Cooling Stage 2 Output to stage 2 mechanical cooling
C	COM	24 Vac Common
R	24 Vac	24 Vac Power (Hot)

Refer to Fig. 50 and 51 for sensor and controls connections.

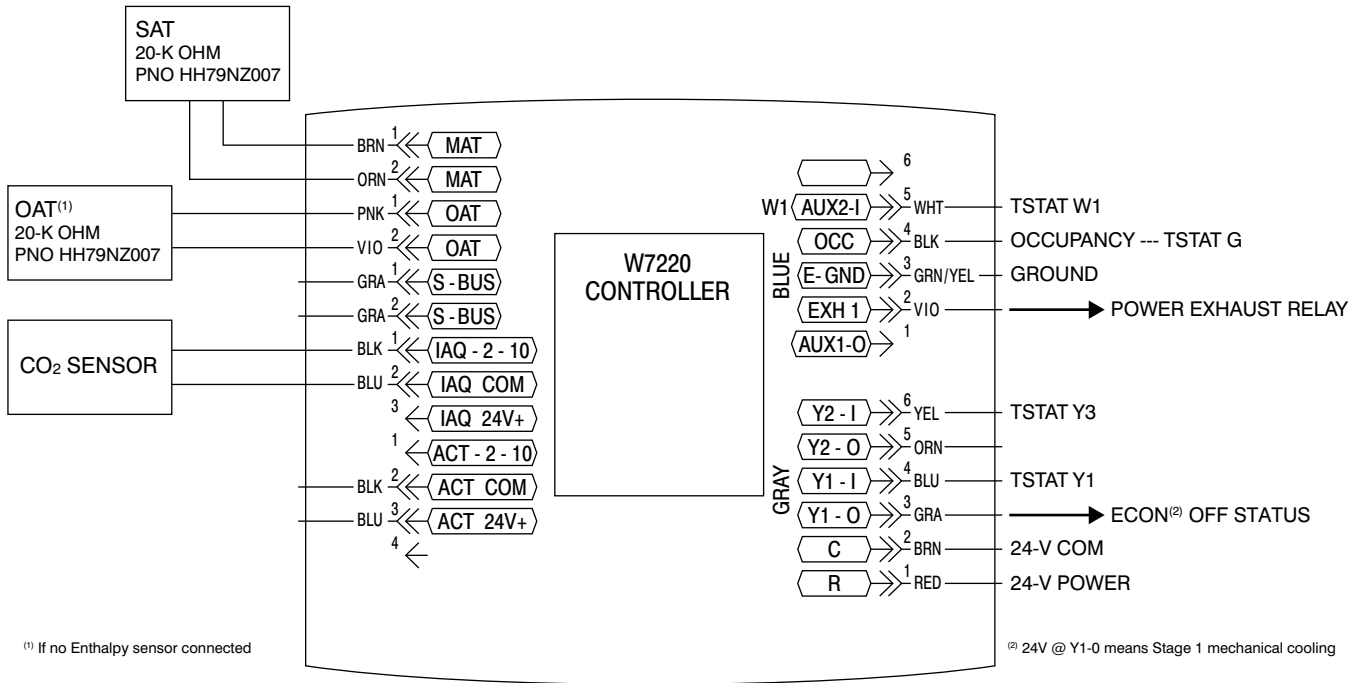

Fig. 50 - W7220 Sensor and Control I/O Connections

a48-9347

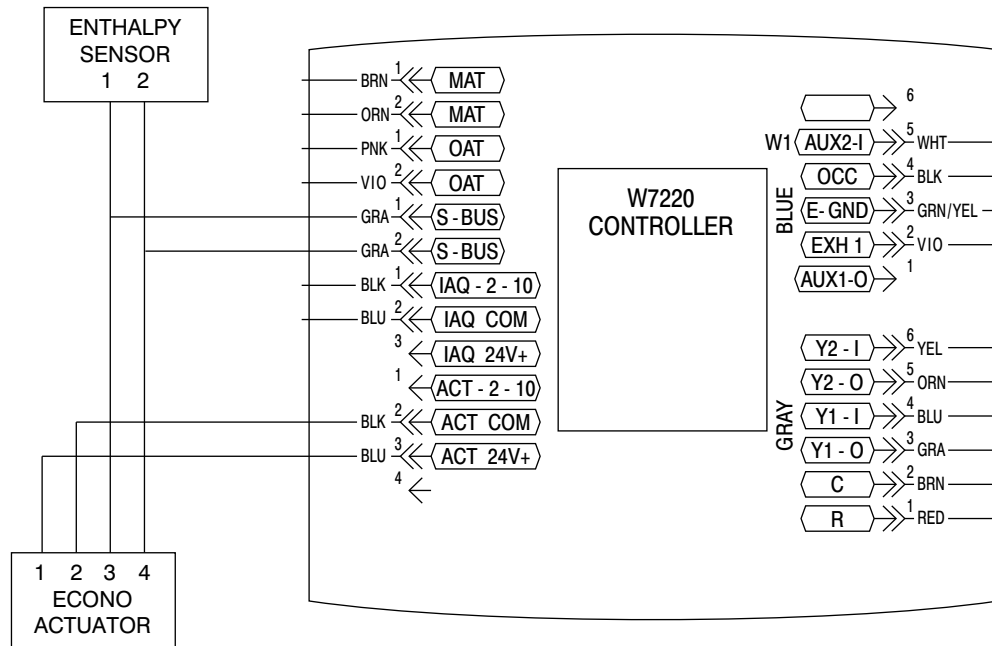

Fig. 51 - Actuator/S-BUS

a48-9348

Economizer Control Configurations

Enthalpy Changeover Control —

Economizer changeover based on outdoor air enthalpy requires an outdoor air enthalpy sensor to replace the OAT sensor. The enthalpy sensor is available as a factory-installed option or as a field-installed accessory (part number HH57AC081). See Fig. 1 for model number nomenclature; check Position #15 for codes N or R indicating a factory-installed enthalpy sensor. Use Fig. 52

and Table 11 to select the enthalpy changeover setting to enter in menu item SETPOINTS -> ENTH CURVE.

Enthalpy Settings —

When the OA temperature, enthalpy and dew point are below the respective setpoints, the Outdoor Air can be used for economizing. Fig. 52 shows the new single enthalpy boundaries in the W7220. There are 5 boundaries (setpoints ES1 through ES5), which are defined by dry bulb temperature, enthalpy and dew point.

Refer to Table 11 for ENTH CURVE setpoint values.

The W7220 calculates the enthalpy and dew point using the OA temperature and humidity input from the OA enthalpy sensor. When the OA temperature, OA humidity and OA dew point are all below the selected boundary, the economizer sets the economizing mode to YES, economizing is available.

When all of the OA conditions are above the selected boundary, the conditions are not good to economize and the mode is set to NO.

Fig. 52 shows the 5 current boundaries. There is also a high limit boundary for differential enthalpy. The high limit boundary is ES1 when there are no stages of mechanical cooling energized and HL (high limit) when a compressor stage is energized.

Table 11 provides the values for each boundary limit.

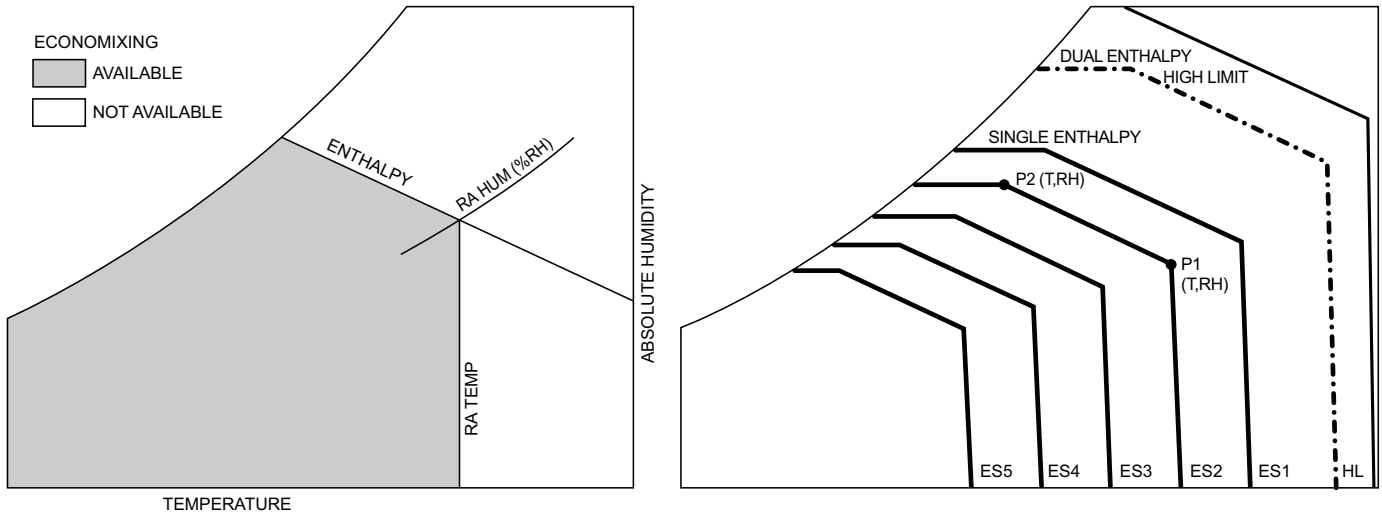

C12015

Fig. 52 - Single Enthalpy Curve and Boundaries

Table 11 – Single Enthalpy and Dual Enthalpy High Limit Curves (EN Units)

Enthalpy Curve	Temp. Dry-Bulb (°F)	Temp. Dewpoint (°F)	Enthalpy (btu/lb/da)	Point P1		Point P2	
				Temp. (°F)	Humidity %RH	Temp. (°F)	Humidity %RH
ES1	80.0	60.0	28.0	80.0	36.8	66.3	80.1
ES2	75.0	57.0	26.0	75.0	39.6	63.3	80.0
ES3	70.0	54.0	24.0	70.0	42.3	59.7	81.4
ES4	65.0	51.0	22.0	65.0	44.8	55.7	84.2
ES5	60.0	48.0	20.0	60.0	46.9	51.3	88.5
HL	86.0	66.0	32.4	86.0	38.9	72.4	80.3

Demand Controlled Ventilation —

Demand Controlled Ventilation (DCV) function requires a space air CO₂ sensor be connected to the W7220 controller. The CO₂ sensor provides a 2 to 10 vdc signal proportional to the space CO₂ level. This sensor is available as a factory-installed option (located in the unit's return air plenum) or as a field-installed accessory. See Fig. 1 for model number nomenclature; check Position #9 for codes E, F, G or H indicating a factory-installed CO₂ sensor. The W7220 automatically recognizes the connection of this sensor and self-enables the DCV function after the Configuration period.

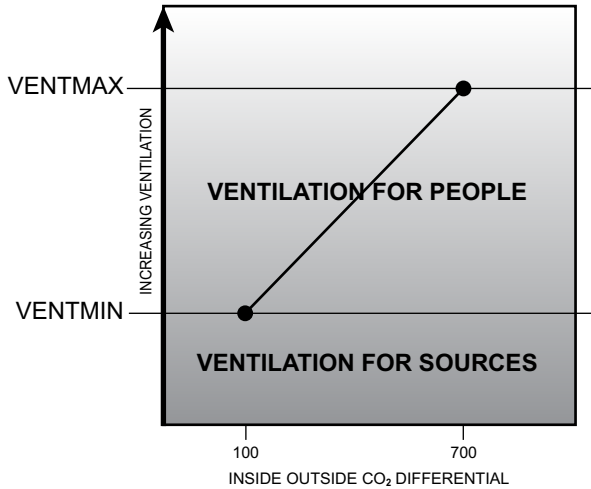

C12167

Fig. 53 - DCV Single-Speed System Setpoints

DCV With Single-Speed Fan System: During DCV, the outside air damper modulates between two user configurations depending upon the signal level of the space or return air CO₂ sensor representing the space occupancy level. The lower of these two positions is referred to as the Minimum IAQ Damper Position (designated VENTMIN) while the higher is referred to as Economizer Minimum Position (designated MINIMUM POSITION or VENTMAX). The VENTMIN position

should be set to an economizer position that brings in enough fresh air to remove contaminants and CO₂ generated by sources other than people; this airflow rate is designated Va. The VENTMAX should be set to an economizer position that brings in enough fresh air to remove contaminants and CO₂ generated by all sources including people at the design condition for maximum space occupancy; this airflow rate is designated Vbz.

DCV With Two-Speed Fan System: Ventilation codes require that the same ventilation rates (Vbz and Va, expressed as CFM) be provided regardless of supply fan speed. When the supply fan speed is reduced, the internal static pressure in the unit's return plenum also decreases. If the same outside air damper position is retained, the airflow rate through the OA damper decreases below the Va and Vbz levels. To restore ventilation rates to design levels, the damper positions VENTMIN and VENTMAX must be automatically adjusted when the fan speed changes. The W7220 provides this function when it is configured for 2-speed fan operation through a second set of damper position setpoints.

During operation at High fan speed, the damper setpoint limits are designated VENTMIN H and VENTMAX H. Damper operation is same as described under Single-Speed Fan above.

During operation at Low fan speed, the damper setpoint limits change to VENTMIN L and VENTMAX L. These settings are higher than the comparable High speed settings and cause the outside air damper to open more to allow the same Va and Vbz airflow rates to be admitted to the space.

Adjust the DCV setpoints VENTMAX H and VENTMAX L with supply fan speed in High speed and Low speed respectively to provide the design load ventilation airflow rate Vbz by measuring outside air temperature, return air temperature and supply air temperature. Make damper position adjustments with at least 10°F temperature difference between the outdoor and return-air temperatures.

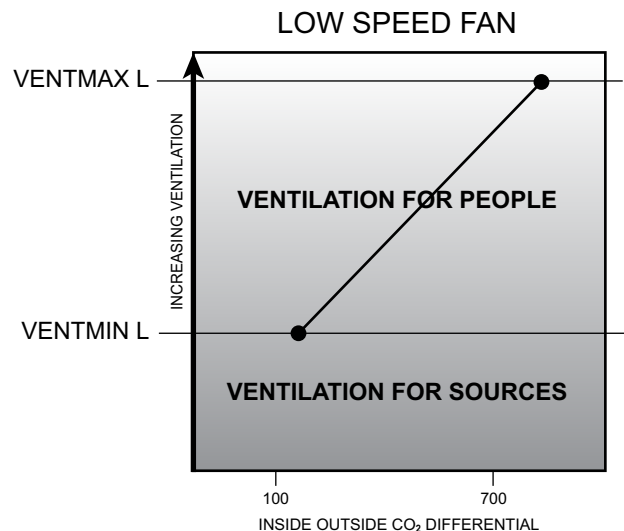
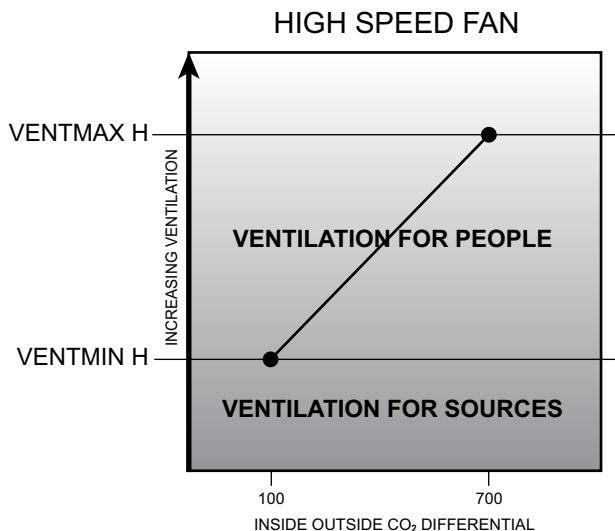

C12168

Fig. 54 - DCV 2-Speed System Setpoints — Same Ventilation CFM at Both Speeds

To determine the damper setpoint position, perform the following procedure for each condition setpoint, with mechanical cooling OFF:

Calculate the appropriate supply air temperature using the following formula:

$$TS = (TO \times Vbz/CFM) + TR \times (CFM - Vbz)/CFM$$

- TS = Supply Air Temperature
- TO = Outdoor Air Temperature
- Vbz = Design Maximum Ventilation CFM
- CFM= Unit Supply Airflow Rate
- TR = Return Air Temperature

As an example:

- Unit Airflow Rate at High Speed is 4000 CFM
- Ventilation CFM at design occupancy Vbz is 1200 CFM
- TO = 60 F
- TR = 75 F

$$\begin{aligned} \text{Required TS} &= 60 \times (1200/4000) + 75 \times (4000 - 1200/4000) \\ &= 60 \times 0.30 + 75 \times 0.70 = 18.0 + 52.5 \\ &= 70.5 \end{aligned}$$

At the W7220 keypad, enter the parameter SETUP -> VENTMAX H and adjust the setpoint value until the observed Supply Air Temperature (MA TEMP) reaches 70.5. Press the ↵ “Enter” key to save this setpoint to controller memory.

When determining VENTMIN setpoints, substitute the value for Va in place of Vbz in the formula.

DCV Setpoint: The SETPOINTS parameter DCV SET defines the space CO₂ level above which the DCV mode begins to open the outside air damper beyond its VENTMIN ventilation lower limit. This setpoint should be a minimum of 100 ppm greater than the outdoor ambient CO₂ level to ensure the outside air will be capable of diluting the space CO₂ level. A typical value for outdoor CO₂ is 400 ppm; adjust the setpoint DCV SET to 500 ppm if outdoor CO₂ level is not known. The factory default value for DCV SET is 1100 ppm.

Economizer Occupancy Control —

The 24-v signal that terminates at the W7220’s OCC input to place the economizer control in Occupied mode when the supply fan starts is routed through the rooftop unit’s Integrated Staging Control Board at its OCCUPANCY jumper. To implement an occupancy control for the economizer operation, connect a contact set at ISC OCCUPANCY quick-connect terminals and cut jumper JMP1. To allow automatic occupancy mode, close the control contacts. To place the economizer in Unoccupied mode, open the control contacts.

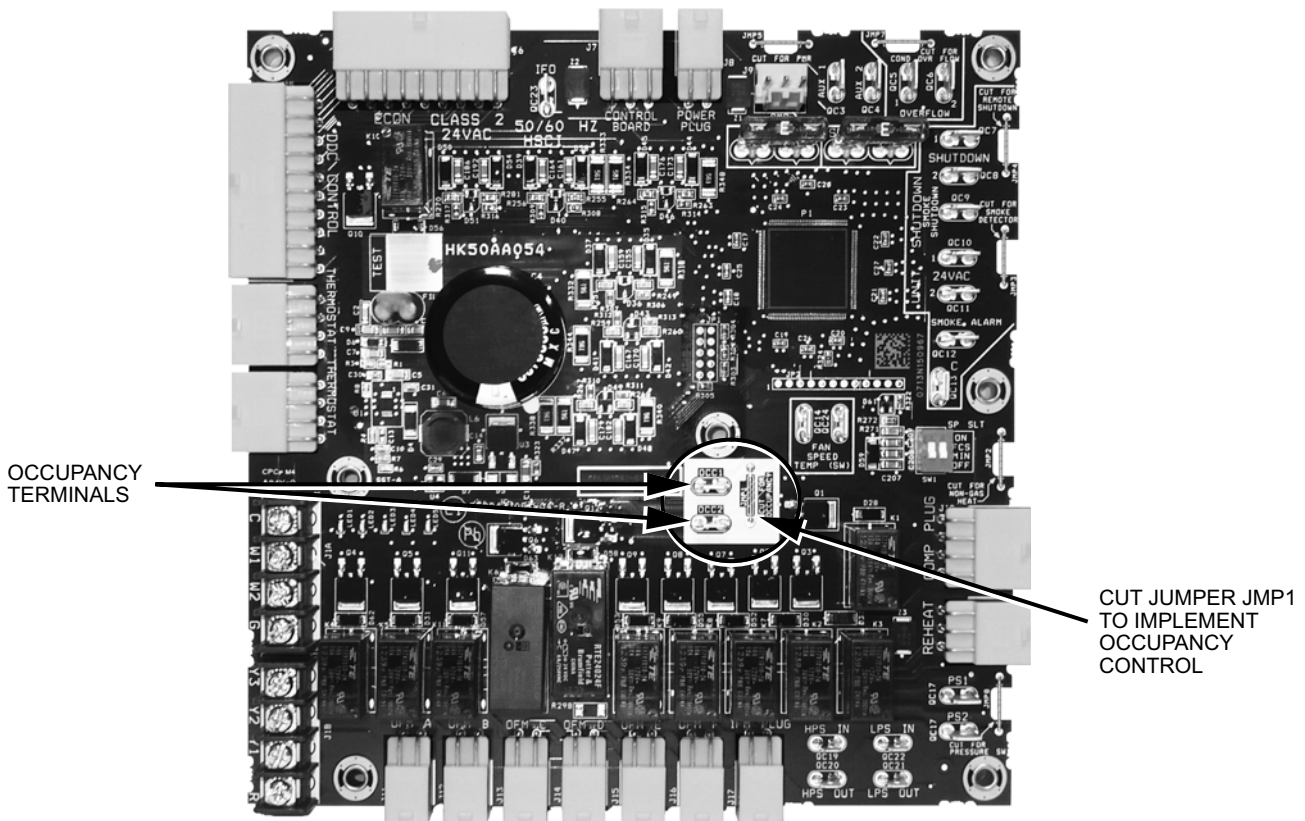

Fig. 55 - Integrated Staging Control (ISC) Board - Occupancy Terminals and Jumper

C13674

Hardware

Actuators —

The EconoMiSer® X damper actuators are direct-coupled types with spring-return. Power is 24-v from the W7220 outputs. Range of rotation is 95-degrees; timing for full-range movement is 90 seconds to drive open in normal operation, 30 seconds in Test Mode and 25 seconds for spring return.

These actuators are S-bus enabled. The S-bus is a proprietary local equipment network that connects the W7220 controller, one S-enabled actuator and up to three S-type enthalpy sensors on a two-wire communication network. The S-bus is polarity-insensitive. Devices attached to the S-bus are automatically recognized by the controller.

Actuator command position is defined in a 2-10 vdc value. 2.0-v is outside air damper position fully-closed (0% open); 10.0-v is damper position fully-open (100% open). See Table 12 to correlate control voltage values to outside air damper opening percentage.

Table 12 – Actuator Voltage vs. Damper Position

Vdc	% Open	Vdc	% Open	Vdc	% Open
2.0	0	4.8	35	7.6	70
2.4	5	5.2	40	8.0	75
2.8	10	5.6	45	8.4	80
3.2	15	6.0	50	8.8	85
3.6	20	6.4	55	9.2	90
4.0	25	6.8	60	9.6	95
4.4	30	7.2	65	10.0	100

These units use a 3-Nm (27 lb-in.) torque model, Honeywell Series MS3103K actuator.

Supply Air Temperature Sensor —

The W7220 controller uses a 20-k ohm analog sensor for Supply Air Temperature (SAT). The thermistor is attached to a ring terminal. The ring terminal is attached to the unit's supply fan housing, downstream of the unit's indoor coil. The SAT sensor is connected to the W7220 input terminals marked MAT. See Table 13 for sensor resistance to temperature correlations.

The W7220 controller requires a valid signal from its SAT channel in order to function. If the SAT connection to the W7220 is lost, the W7220 will initiate an alarm condition immediately. No economizing operation will be permitted until this alarm is cleared.

Table 13 – SAT/OAT Sensor Characteristics

Deg C	Ohms	Deg F	Ohms
-30	415156	-20	386130
-25	301540	0	193070
-20	221210	20	101820
-15	163834	32	70200
-10	122453	40	55420
-5	92382	45	47771
0	70200	50	41258
5	53806	55	35725
10	41561	60	31035
15	32341	65	27069
20	25346	70	23719
25	20000	77	20000
30	15886	80	18473
35	12698	100	11544
40	10212	120	6768
45	8261		
50	6720		

Outside Air Temperature Sensor —

EconoMiSer X systems equipped with outdoor dry bulb temperature changeover control include a 20-k ohm analog sensor to measure Outdoor Air Temperature (OAT). This is the same sensor used for the SAT function; see Table 13 for resistance vs temperature characteristics.

The OAT sensor is attached to the outside air damper frame. It is connected to the W7220's OAT input terminals.

If an accessory enthalpy sensor is added to an EconoMiSer X system with factory dry bulb changeover, disconnect this OAT sensor wiring at the W7220's OAT input terminals.

Enthalpy Control Sensor Configuration—

The W7220 economizer control system can accommodate up to three S-bus enthalpy sensors. On EconoMiSer X models with factory-installed Enthalpy Changeover control, one S-bus sensor is provided in the economizer outdoor section. Additional sensors may be added to measure Return Air and Discharge Air conditions.

The Enthalpy Control sensor (Part Number: HH57AC081) communicates with the W7220 Economizer controller on the two-wire local equipment network bus (S-bus) and can either be wired using a two-pin header or using a side connector. This sensor is used for all OAT (Outdoor Air Temperature), RAT (Return Air Temperature) and DAT (Discharge Air Temperature), depending on how its three position DIP switch is set.

Use Fig. 56 and Table 14 to locate the wiring terminals for each Enthalpy Control sensor.

Use Fig. 56 and Table 15 to set the DIP switches for the desired use (location) of the sensor.

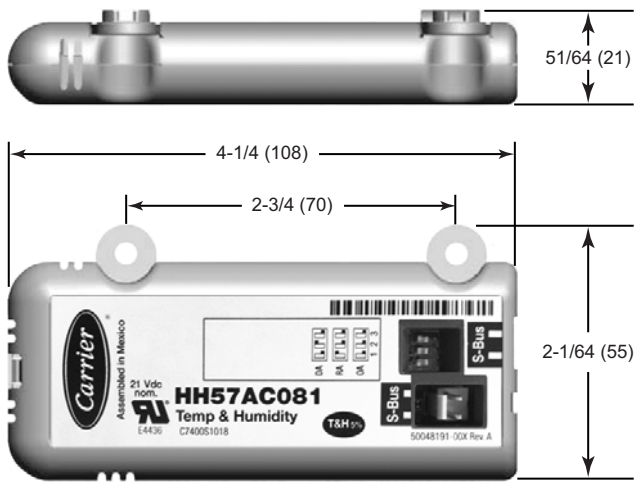

NOTE: Dimensions are in inches. Dimensions in () are in mm.

a50-9614

Fig. 56 - Enthalpy Control Sensor, Dimensions and DIP Switch Location

Table 14 – Enthalpy Control Sensor Wiring Terminations*

Terminal		Type	Description
Nbr	Label		
1	S-BUS	S-BUS	S-Bus Communications (Enthalpy Control Sensor Bus)
2	S-BUS	S-BUS	S-Bus Communications (Enthalpy Control Sensor Bus)

* Terminals are polarity insensitive.

Table 15 – Enthalpy Control Sensor DIP Switch Settings

Use	DIP Switch Positions for Switches 1, 2, & 3		
	1	2	3
DA	OFF	ON	OFF
RA	ON	OFF	OFF
OA	OFF	OFF	OFF

Legend

DA = Discharge Air
 RA = Return Air
 OA = Outside Air

When a S-bus sensor is connected to an existing network, it will take 60 minutes for the network to recognize and auto-configure itself to use the new sensor. During the 60 minute setup period, no alarms for sensor failures (except SAT) will be issued and no economizing function will be available.

Operating Sequences

Staged Air Volume (3-Speed) Fan Motor —

The Integrated Staging Control (ISC) Board in the main unit determines the operating speed (LOW/MED/HIGH) of the indoor fan based on space thermostat demand conditions. See Table 16 for this logic.

Table 16 – Supply Fan Speed Logic without Economizer

T*STAT OUTPUT				
G/OCC	0-V	24-V	0-V	0-V
Y1	0-V	24-V	0-V	0-V
Y2	0-V	0-V	24-V	0-V
Y3	0-V	0-V	0-V	24-V
W1	0-V	0-V	0-V	24-V
W2	0-V	0-V	0-V	24-V
SUPPLY FAN MOTOR SPEED	OFF	LOW	MED	HIGH

W7220 Economizer Control —

Tables 17 and 18 provide the W7220 Input/Output Logic. Table 17 describes economizer functions for a unit without a CO₂ sensor. Table 18 describes economizer functions for a unit with Demand Controlled Ventilation (CO₂ sensor connected). The supply fan speed is included in these tables for reference; this is neither an input or output of the W7220 controller.

Base Unit Controls —

Base unit includes standard electro-mechanical controls, Staged Air Volume (3-speed supply fan motor with VFD), EconoMi\$er® X (with W7220 controller) and thermostat or unitary controller that energizes the G terminal in cooling and heating to control the supply fan operation.

Cooling, Unit With EconoMi\$er X Without CO₂ Sensor —

For Occupied mode operation of the EconoMi\$er X control, there must be a 24-v signal at terminal G at the unit's Integrated Staging Control Board from the thermostat; supply fan motor will start and run in Low Speed. The signal at G is connected to W7220 input OCC, placing the EconoMi\$er X control in Occupied mode; the economizer actuator is commanded open to the MIN POS L ventilation position. Removing the signal at OCC places the EconoMi\$er X control in Unoccupied mode; the economizer actuator is driven back to full-closed position.

When free cooling using outside air is not available, the unit cooling sequence will be controlled directly by the space thermostat. Thermostat call for Stage 1 Cooling energizes ISC terminals G and Y1; supply fan motor starts and runs in Low Speed. The Y1 demand is received at W7220 terminal Y1-I. Outside air damper position will be at MIN POS L. W7220 output Y1-O is energized; first stage mechanical cooling starts.

As space temperature falls and space cooling load is satisfied, the thermostat will remove its call for first stage cooling; ISC terminal Y1 call is removed. The W7220 input Y1-I is removed; output Y1-O is de-energized, stopping first stage cooling.

When ISC terminal Y1 is de-energized, terminal G may remain energized, indicating Continuous Fan operation.

The supply fan motor will continue to run in Low Speed. W7220 input OCC remains energized; the outside air damper remains in MIN POS L. If ISC terminal G is also de-energized with Y1, indicating AUTO Fan operation, then the supply fan motor will stop. The W7220 input at OCC is removed; the outside air damper closes.

If the space temperature continues to rise, the thermostat will call for second stage cooling; ISC terminal Y2 is also energized. The supply fan motor shifts to MED Speed. Outside air damper position will remain in MIN POS L, second stage cooling starts.

As space temperature falls, the thermostat will remove its call for second stage cooling; ISC terminal Y2 call is removed. The supply fan motor shifts back to Low Speed. The outside air damper remains at MIN POS L and the ISC board will stop second stage mechanical cooling.

If the space temperature continues to rise, the thermostat will call for third stage cooling; ISC terminal Y-3 is also energized. The supply fan motor shifts to High Speed. The outside air damper position will shift to MIN POS H, third stage cooling starts.

As space temperature falls, the thermostat will remove its call for third stage cooling; ISC terminal Y3 call is removed. The supply fan will shift to Medium Speed. The outside air damper position is repositioned to MIN POS L and stop third stage mechanical cooling.

When free cooling is available as determined by the appropriate changeover command (outdoor dry bulb,

outdoor enthalpy, differential dry bulb or differential enthalpy), a space thermostat call for Stage 1 Cooling energizes ISC terminals G and Y1; supply fan motor starts and runs in High Speed. The G demand is received at W7220 input OCC; outside air damper moves to MIN POS L. The Y1 demand is received at W7220 terminal Y1-I. The W7220 economizer control will modulate the outside air damper open and closed to maintain the unit cooling supply air temperature at setpoint MAT SET (default 53°F (12°C)). Compressor will not run.

During free cooling operation, a supply air temperature (SAT) above MAT SET will cause the outside air damper to modulate between MIN POS L setpoint and 100% open. As SAT decreases and approaches setpoint MA LO SET (default 45°F (7°C)), the outside air damper will maintain at the MIN POS L setting. With SAT below MA LO SET, the outside air damper will be closed or at minimum (see FREEZE POS) When SAT rises to MA LO SET plus 3°F, the outside air damper will re-open to MIN POS L setting.

Should 100% outside air not be capable of satisfying the space cooling load, space temperature will rise and the thermostat will call for second stage cooling; ISC terminal Y2 is also energized. The supply fan motor remains at High Speed. Outside air damper position will remain at MIN POS L, starting second stage cooling (Compressor 1 operation). Damper will modulate to maintain SAT at MAT SET concurrent with Compressor 1 operation.

Table 17 – W7220 Input/Output without CO₂ Sensor

INPUTS				Ref: FAN SPD*	OUTPUTS			
DEMAND CONTROLLED VENTILATION	OUTSIDE AIR Good to economize?	Y1-I	Y2-I		Mechanical Cooling Stage		Occupancy	
					Y1-O/1ST	Y2-O/2ND	OCC Yes	OCC No
NO CO ₂ SENSOR	No	Off	Off	Low	0-v/Off	0-v/Off	MIN POS L	Closed
		On	Off	Low	24-v/On	0-v/Off	MIN POS L	Closed
		On	On	High	24-v/On	24-v/On	MIN POS H	Closed
	Yes	Off	Off	Low	0-v/Off	0-v/Off	MIN POS L	Closed
		On	Off	Low	0-v/Off	0-v/Off	Modulating: MIN POS L to Full-Open	Modulating: Closed to Full-Open
		On	On	High	2SP DELAY†; 24v/On	0-v/Off **	Modulating: MIN POS H to Full-Open	Modulating: Closed to Full-Open

* Fan Speed for reference only; this is not an input or output function of the W7220.

† See Menu ADV SETUP -> 2SP FAN DELAY for details.

** See Menu ADV SETUP -> STG# DLY. With Stage 3 delay enabled, control can turn on 2nd stage of cooling Y2-O after delay if the call for Y2-I has not been satisfied.

Table 18 – W7220 Input/Output with Demand Controlled Ventilation (DCV)

INPUTS				Ref: FAN SPD*	OUTPUTS			
DEMAND CONTROLLED VENTILATION	OUTSIDE AIR Good to economize?	Y1-I	Y2-I		Mechanical Cooling Stage		Occupancy	
					Y1-O/1ST	Y2-O/2ND	OCC Yes	OCC No
Below set	No	Off	Off	Low	0-v/Off	0-v/Off	VENTMIN L	Closed
		On	Off	Low	24-v/On	0-v/Off	VENTMIN L	Closed
		On	On	High	24-v/On	24-v/On	VENTMIN H	Closed
	Yes	Off	Off	Low	0-v/Off	0-v/Off	VENTMIN L	Closed
		On	Off	Low	0-v/Off	0-v/Off	Modulating: VENTMIN L to Full-Open	Modulating: Closed to Full-Open
		On	On	High	2SP DELAY †; 24v/On	0-v/Off **	Modulating: VENTMIN H to Full-Open	Modulating: Closed to Full-Open
Above set	No	Off	Off	Low	0-v/Off	0-v/Off	Modulating: VENTMIN L to VENTMAX L	Closed
		On	Off	Low	24-v/On	0-v/Off	Modulating: VENTMIN L to VENTMAX L	Closed
		On	On	High	24-v/On	24-v/On	Modulating: VENTMIN H to VENTMAX H	Closed
	Yes	Off	Off	Low	0-v/Off	0-v/Off	Modulating: VENTMIN L to VENTMAX L	Closed
		On	Off	Low	0-v/Off	0-v/Off	Modulating: VENTMIN L to Full-Open	Modulating: Closed to Full-Open
		On	On	High	2SP DELAY †; 24v/On	0-v/Off **	Modulating: VENTMIN H to Full-Open	Modulating: Closed to Full-Open

* Fan Speed for reference only; this is not an input or output function of the W7220.

† See Menu ADV SETUP -> 2SP FAN DELAY for details.

** See Menu ADV SETUP -> STG# DLY. With Stage 3 delay enabled, control can turn on 2nd stage of cooling Y2-O after delay if the call for Y2-I has not been satisfied.

As space temperature falls, the thermostat will remove its call for second stage cooling; ISC terminal Y2 call is removed. The supply fan motor remains High Speed. The outside air damper limit is repositioned to between MIN POS L and 100% open. Second stage cooling (Compressor 1 operation) stops. As space temperature continues to fall and space cooling load is satisfied, the thermostat will remove its call for first stage cooling; ISC terminal Y1 call is removed. The W7220 input Y1-I is removed; free cooling mode ends. Outside air damper will remain at MIN POS L if supply fan remains in operation (CONT FAN) or to closed if supply fan stops (AUTO FAN).

Should 100% outside air and second stage cooling (Compressor 1 operation) not be capable of satisfying the space cooling load, space temperature will rise and the thermostat will call for third stage cooling; ISC terminal Y3 is also energized, starting third stage cooling (Compressor 2 operation). The supply fan motor will remain at High Speed. The Y3 demand is received at W7220 input Y2-I. The outdoor air damper position will modulate from MIN POS H to 100% Open to maintain SAT at MAT SET concurrent with Compressor 2 operation.

As space temperature falls, the thermostat will remove its call for third stage cooling; ISC terminal Y3 call is removed. The supply fan will remain at High Speed. The W7220 input Y2-I is also removed; the outside air damper is repositioned to modulate from MIN POS L to 100% Open, third stage cooling (Compressor 2 operation) stops.

Power Exhaust: If accessory power exhaust is installed, the power exhaust fan motors will be energized by the economizer control as the dampers open above the setpoint EXH1 SET L during Low Speed operation or EXH1 SET H during High Speed fan operation. The EXH1 output will be de-energized as the dampers close below the EXH1 setpoint value.

Damper movement from full closed to full open (or vice versa) will take approximately 1-1/2 minutes.

Heating With EconoMiSer® X —

When the space temperature calls for heat (W1 closes), ISC terminal W1 is energized. The supply fan will start and run in High Speed. The W1 signal will connect to W7220 input AUX2I; the outside air damper will move to MIN POS H. Unit heating sequence will follow base unit control sequences.

Demand Controlled Ventilation —

If a space or return air CO₂ sensor is connected to the EconoMiSer[®] X control, a Demand Controlled Ventilation strategy will operate automatically.

When the space CO₂ level is below setpoint DCV SET (default 1100 ppm), the minimum ventilation position for the outside air damper will be reset to lower settings suited for offsetting CO₂ loads from space sources not including people. The settings will vary according to supply fan speed. When the supply fan speed is Low, the DCV minimum ventilation point is VENTMIN L. When the supply fan speed is High, the DCV minimum ventilation point is VENTMAX H.

As the CO₂ level in the space increases above the setpoint DCV SET (default 1100 ppm), the DCV ventilation position of the outside air damper will be increased proportionally, until the Maximum Ventilation setting is reached. The settings will vary according to supply fan speed. When the supply fan speed is Low, the DCV maximum ventilation point is VENTMAX L. When the supply fan speed is High, the DCV maximum ventilation point is VENTMAX H.

DCV operation will float between its VENTMIN and VENTMAX settings, never exceeding the VENTMAX limit as the space CO₂ level varies according to changes in people occupancy levels.

During concurrent demand for DCV and free cooling, the outdoor-damper will follow the higher demand condition from the DCV mode or from the free-cooling mode.

Setup and Configuration

Before being placed into service, the W7220 Economizer module must be setup and configured for the installed system according to project control specifications.

Inspect all wiring connections at the Economizer module's terminals, and verify compliance with the installation wiring diagrams.

Initial Menu Display —

On initial start up, Honeywell displays on the first line and Economizer W7220 on the second line. After a brief pause, the revision of the software appears on the first line and the second line will be blank.

Time-out and Screensaver —

When no buttons have been pressed for 10 minutes, the LCD displays a screen saver, which cycles through the Status items. Each Status items displays in turn and cycles to the next item after 5 seconds.

IMPORTANT: During setup, the Economizer module is live at all times.

Setup and configuration involves stepping through three menus and enabling required functions and re-selecting setpoints to meet project requirements. The menus used are SYSTEM SETUP, ADV SETUP and SETPOINTS.

Obtain a copy of the project control specifications before starting setup and configuration process.

NOTE: W7220 will be in the “set up” mode for the first 60 minutes after powered. If a sensor for OA air or S-bus device (sensor, actuator) is disconnected during the set up mode, the W7220 will not alarm that failure. The SAT sensor is a system “critical” sensor, if the SAT sensor is removed during the set up mode, the W7220 will alarm. After 60 minutes the W7220 controller will change to operation mode and all components removed or failed will alarm in the operation mode.

For this application with the 2-speed supply fan option, note that parameters EQUIPMENT, AUX2I and FAN TYPE have required settings. Check that these parameters are set at these required settings:

EQUIPMENT must be CONV
AUX2I must be W
FAN SPEED must be 2SPEED

Press the ⏮ (EXIT) button to exit the SYSTEM SETUP menu and return to top level menu. Scroll down to ADV SETUP menu and press ⏴ (ENTER) button to enter this menu. Scroll down through the list of parameters and adjust settings as required. Be sure that the message CHANGE STORED appears with every change in parameter setting.

Press the ⏮ (EXIT) button to exit the ADV SETUP menu and return to top level menu. Scroll down to SETPOINTS menu and press ⏴ (ENTER) button to enter this menu. Scroll down through the list of parameters and adjust settings as required. Be sure that the message CHANGE STORED appears with every change in parameter setting.

SETPOINT Defaults: The default setpoint values represent many years of successful experience with economizing systems. Any changes that represent significant deviations from the default values should be well considered.

DCV SETPOINT: The default value for DCV SET is 1100 ppm. It is recommended that this setpoint be adjusted down to 500 ppm (or CO₂ level of outdoor air plus 100 ppm, whichever is higher) to permit an earlier initiation of the DCV mode as space occupancy increases.

Checkout

For checkout, review the Status of each configured parameter by observing the scrolling display from the Screensaver mode or by entering the STATUS menu.

Use the Checkout menu (see Table 8 on page 38) to test the damper operation and any configured outputs. Only items that are configured are shown in the Checkout menu.

To perform a Checkout test:

1. Scroll to the desired test in the Checkout menu using the the ▲ and ▼ buttons.
2. Press the ← button to select the item.
3. RUN? appears.
4. Press the ← button to start the test.
5. The unit pauses and then displays IN PROGRESS.
6. When the test is complete, DONE appears.
7. When all desired parameters have been tested, press the ⬆ (Menu up) button to end the test.

The Checkout tests can all be performed at the time of installation or at any time during the operation of the system as a test that the system is operable.

▲ CAUTION

EQUIPMENT DAMAGE HAZARD

Failure to follow this caution may result in equipment damage.

Be sure to allow enough time for compressor startup and shutdown between checkout tests so that you do not short-cycle the compressors.

Status —

Use the STATUS menu (see pages 34 and 35) to check the parameter values for the various devices and sensors configured.

Calibration of Sensors —

There are up to six sensor calibration settings available in the ADV SETUP menu (depending on which sensors are connected to the W7220). See page 37 for this menu.

Resetting All Defaults —

Menu SYSTEM SETUP contains parameter FACTORY DEFAULT. This parameter will reset all setpoints back to factory default values.

To reset all values to defaults, scroll to the SYSTEM SETUP menu, enter the menu and scroll to parameter FACTORY DEFAULT. Enter this parameter and change the display value from NO to YES. Press ENTER ←.

After resetting all values, scroll up in SYSTEM SETUP to ensure the three parameters requiring special values for use with 2-speed fan system are correct.

Troubleshooting

Power Up Delay—

Upon power up (or after a power outage or brownout) the W7220 controller module begins a 5-minute power up delay before enabling mechanical cooling.

Power Loss (Outage or Brownout) —

All setpoints and advanced settings are restored after any power loss or interruption.

NOTE: If the power goes below 18 Vac, the W7220 controller module assumes a power loss and the 5-minute power up delay will become functional when power returns above 18 Vac.

Alarms —

The Economizer module provides alarm messages that display on the 2-line LCD.

NOTE: Upon power up, the module waits 60 minutes before checking for alarms. This allows time for all the configured devices (e.g. sensors, actuator) to become operational. The exception is the SAT sensor which will alarm immediately.

If one or more alarms are present and there has been no keypad activity for at least 5 minutes, the Alarms menu displays and cycles through the active alarms. You can also navigate to the Alarms menu at any time. The list of alarms included in Table 8 (see page 38) is not a complete list of available alarm messages. Each sensor has alarms for temperature, humidity and enthalpy. The list of possible alarms will vary from unit to unit as different sensors are connected.

Clearing Alarms —

Once the alarm has been identified and the cause has been removed (e.g. replaced faulty sensor) the alarm can be cleared from the display.

To clear an alarm, perform the following:

1. Navigate to the desired alarm.
2. Press the ← button.
3. ERASE? displays.
4. Press the ← button.
5. ALARM ERASED displays.
6. Press the ⬆ (Menu up/Exit) button to complete the action and return to the previous menu.

NOTE: If the alarm still exists after you clear it, it is redisplayed within 5 seconds.

Table 19 – Operating Issues and Concerns

Issue or Concern	Possible Cause and Remedy
My outdoor temperature reading on the STATUS menu is not accurate.	Check the sensor wiring: <ul style="list-style-type: none"> • Enthalpy sensors are to be wired to the S–Bus terminals. • Temperature sensors are to be wired to the OAT and MAT terminals.
If my enthalpy sensor drifts in accuracy over time, can I re–calibrate it?	The sensor are not able to be re–calibrated in the field. However there is a menu item under the ADVANCED menu where you are able to input a limited offset in temperature and humidity for each sensor you have connected to the economizer.
Can I go back to factory defaults and start over?	Under the SYSTEM SETUP menu you can change the setpoints to the factory defaults.
Will I be able to see the LCD screen when it is in the unit?	The LCD screen has a backlight that is always illuminated.
What is a good setpoint for the Supply Air Temperature (SAT)?	The supply air temperature is the temperature of air that you want to supply to the space. In a commercial building, this is between 50 to 55°F (10 to 13°C). The supply air is the mixing of the return air and the outdoor air.
I am using enthalpy sensors. Why did the control ask me to input a dry bulb changeover temperature?	In the event the humidity sensor in the enthalpy sensors fails, the backup algorithm in the control is to default to the temperature sensor in the enthalpy sensor.
In checkout, the outdoor damper closes when I command it to open.	Check the actuator linkage or rotation. In the CHECKOUT mode, the outdoor damper should drive open or closed with the return air damper having the opposite effect.
How do I set my minimum position?	The minimum position is set using the VENTMIN and VENTMAX setup in the SETPOINTS menu. VENTMIN is the minimum ventilation required when using an occupancy sensor and VENTMAX is the minimum ventilation when not using an occupancy sensor for Demand Controlled Ventilation. The VENTMAX position is set the same as with the potentiometer on the analog economizers and is the output voltage to the damper actuator. The range is 2 Vdc closed OA damper and 10 Vdc open OA damper.
What if my damper does not go completely closed in the checkout operation?	Check the damper linkage or hub to make sure the damper is able to close completely.
How do I set the OCC?	There are two settings for the OCC setting, INPUT and ALWAYS. INPUT is from the space thermostat, if it has an occupancy output. ALWAYS is the unit in the occupied mode, if the economizer is powered (fan on).
Does the economizer save my program values if the unit loses power?	Yes, once the changes are stored in the controller they will be stored until they are changed by the operator.
If the unit is left in checkout, how long will the unit stay in checkout mode without input?	The unit will remain in checkout for 10 minutes, then return to normal operation.

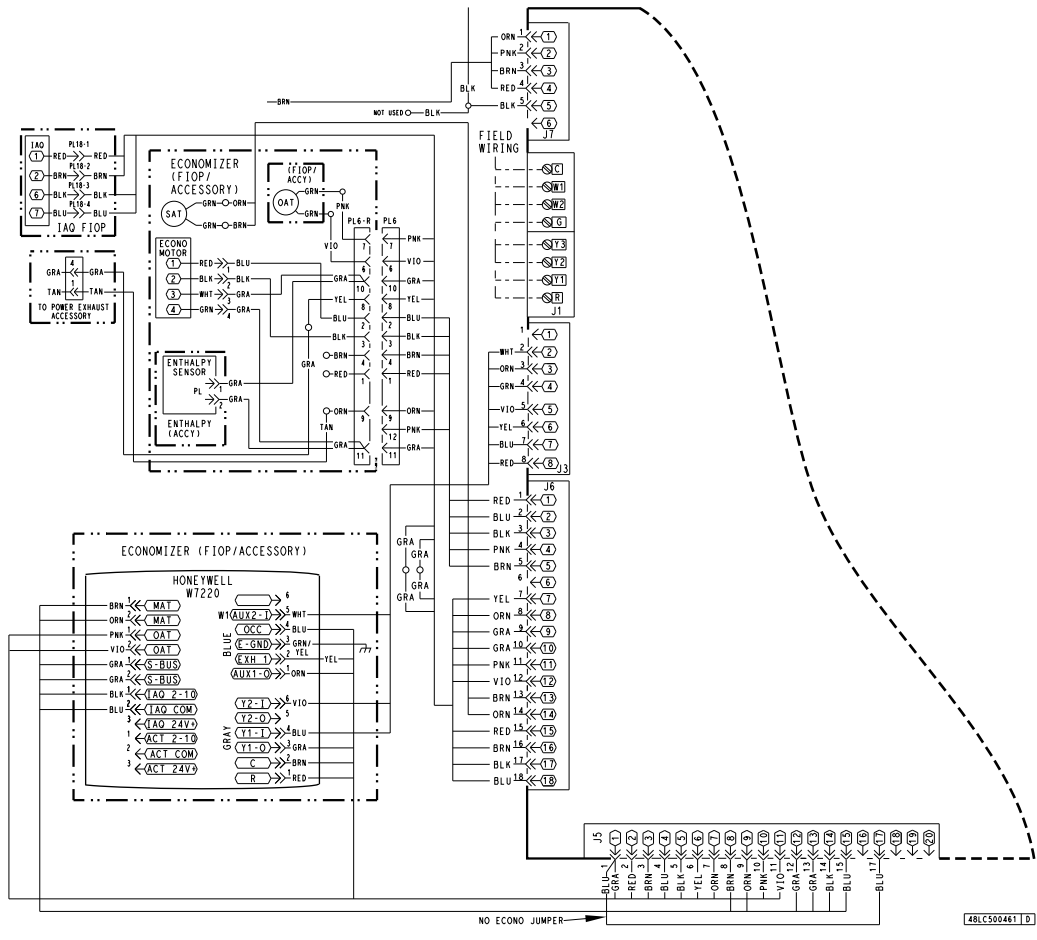

Fig. 57 - Typical EconMiSer® X Wiring Diagram

a48-9322

CONTROL SET POINT AND CONFIGURATION LOG

Project Name/Location: _____

Model Number: _____

Serial Number: _____

Date: _____

Technician _____

Menu Tables:

1. SYSTEM SETUP
2. ADVANCED SETUP
3. SETPOINTS

Menu 1: System Setup

Parameter	Project Value	Parameter Default Value	Parameter Range and Increment	Notes
INSTALL		01/01/10		Display order = MM/DD/YY Setting order = DD, MM, then YY
UNITS DEG		_F	_F or _C	Sets economizer controller in degrees Fahrenheit or Celsius.
EQUIPMENT		CONV	CONV required for 2-speed mode	CONV = conventional; HP O/B = Enable Heat Pump mode; not available with 2-speed See Menu Note 4 (on page 38)
AUX2 I		W	W required for 2-speed mode	W = Informs controller that system is in heating mode. SD = Enables configuration of shutdown (not available on 2-speed) See Menu Note 4 (on page 38)
FAN TYPE		2speed	2speed required	Sets the economizer controller for operation of 1 speed or 2 speed indoor fan system. See Menu Note 4 (on page 38)
FAN CFM		5000cfm	100 to 15000 cfm;	UNIT DESIGN AIRFLOW (CFM) Enter ONLY if using DCVCAL ENA = AUTO The value is found in the Project Submittal documents for the specific RTU.
AUX OUT		NONE	NONE ERV EXH2 SYS	Select OUTPUT for AUX1 O relay NONE = not configured (output is not used) ERV = Energy Recovery Ventilator EXH2 = second damper position relay closure for second exhaust fan SYS = use output as an alarm signal
OCC		INPUT	INPUT or ALWAYS	OCCUPIED MODE BY EXTERNAL SIGNAL When using a setback thermostat with occupancy out (24 Vac), the 24-Vac is input to the OCC terminal. RTU control circuit provides 24-Vac to OCC through OCCUPIED terminals on Integrated Staging Control Board.
FACTORY DEFAULT		NO	NO or YES	Resets all set points to factory defaults when set to YES. LCD will briefly flash YES and change to NO but all parameters will change to the factory default values. RECHECK AUX2 I and FANTYPE for required 2-speed values.

Menu 2: Advanced Setup

Parameter	Project Value	Parameter Default Value	Parameter Range and Increment	Notes
MA LO SET		45°F (7°C)	35 to 55°F; (2 to 13°C) incremented by 1°	SUPPLY AIR TEMPERATURE LOW LIMIT Temperature to achieve Freeze Protection (close damper and alarm if temperature at SAT location falls below setup value)
FREEZE POS		CLO	CLO or MIN	FREEZE PROTECTION DAMPER POSITION Damper position when freeze protection is active CLO = closed MIN = MIN POS or VENTMAX
CO2 ZERO		0ppm	0 to 500 ppm; Increment by 10	CO ₂ ppm level to match CO ₂ Sensor start level.
CO2 SPAN		2000ppm	1000 to 3000 ppm; Increment by 50	CO ₂ ppm span to match CO ₂ sensor.
STG3 DLY		2.0h	0 min, 5 min, 15 min, then 15 min intervals. Up to 4 h or OFF	COOLING STAGE 3 DELAY Delay after stage 2 for cool has been active. Turns on 2nd stage of cooling when economizer is 1st stage and mechanical cooling is 2nd
SD DMPR POS		CLO	CLO or OPN	Function NOT AVAILABLE with 2--speed mode
DCVCAL ENA		MAN	MAN (manual)	Turns on the DCV automatic control of the dampers. Resets ventilation
MAT T CAL	0.0	1.0°F (or °C)	+/- 2.5°F (+/-1.4°C)	SUPPLY AIR TEMPERATURE CALIBRATION Allows for the operator to adjust for an out of calibration supply air temperature (SAT) sensor
OA T CAL	2.0	3.0°F (or °C)	+/- 2.5°F (+/-1.4°C)	OUTSIDE AIR TEMPERATURE CALIBRATION Allows for the operator to adjust for an out of calibration outside air temperature (OAT) sensor
OA H CAL		0% RH	+/- 10% RH	OUTSIDE AIR HUMIDITY CALIBRATION Allows for the operator to adjust for an out of calibration of outside air enthalpy sensor
RA T CAL	4.0	5.0°F (or °C)	+/- 2.5°F (+/-1.4°C)	RETURN AIR TEMPERATURE CALIBRATION Allows for the operator to adjust for an out of calibration return air temperature (RA) sensor
RA H CAL		0% RH	+/- 10% RH	RETURN AIR HUMIDITY CALIBRATION Allows for the operator to adjust for an out of calibration return air enthalpy sensor
DA T CAL	0.0	1.0°F (or °C)	+/- 2.5°F (+/-1.4°C)	DISCHARGE AIR TEMPERATURE CALIBRATION Allows for the operator to adjust for an out of calibration discharge air temperature (DAT) sensor
2SP FAN DELAY		5 Minutes	0 to 20 minutes in 1 minute increments	TIME DELAY ON 2ND STAGE ECONOMIZING While in the Economizing mode, this is the delay between thermostat Y2 call and Y1-O output to mechanical cooling stage, to allow high speed fan operation to attempt to cool space first.

Menu 3: Setpoints

Parameter	Project Value	Parameter Default Value	Parameter Range and Increment	Notes
MAT SET		53°F (12°C)	38 to 65°F; (3 to 18°C) increment by 1°	SUPPLY AIR SETPOINT Setpoint determines where the economizer will modulate the OA damper to maintain the supply air temperature. See Menu Note 2 (on page 38).
LOW T LOCK		32°F (0°C)	-45 to 80°F (-43 to 27°C) increment by 1°	COMPRESSOR LOW TEMPERATURE LOCKOUT Setpoint determines outdoor temperature when the mechanical cooling cannot be turned on.
DRYBLB SET		63°F (17°C)	48 to 80°F; (9 to 27°C) increment by 1°	OA DRY BULB TEMPERATURE CHANGEOVER SETPOINT Setpoint determines where the economizer will assume outdoor air temperature is good for free cooling; e.g.: at 63°F (17°C), unit will economize at 62°F (16.7°C) and below and not economize at 64°F (17.8°C) and above. There is a 2°F (1.1°C) deadband. See Menu Note 3 (on page 38).
ENTH CURVE		ES3	ES1, ES2, ES3, ES4, or ES5	ENTHALPY CHANGEOVER CURVE (Requires enthalpy sensor option) Enthalpy boundary "curves" for economizing using single enthalpy.
DCV SET		1100ppm	500 to 2000 ppm; increment by 100	DEMAND CONTROLLED VENTILATION SETPOINT Displays only if CO ₂ sensor is connected. Setpoint for Demand Controlled Ventilation of space. Above the setpoint, the OA dampers will modulate open to bring in additional OA to maintain a space ppm level below the setpoint.
MIN POS L		6.0 V	2 to 10Vdc	VENTILATION MINIMUM POSITION AT LOW SPEED Displays ONLY if a CO ₂ sensor is NOT connected.
MIN POS H		4.4 V	2 to 10Vdc	VENTILATION MINIMUM POSITION AT HIGH SPEED Displays ONLY if a CO ₂ sensor is NOT connected.
VENTMAX L		6.0 V	2 to 10Vdc	DCV MAXIMUM DAMPER POSITION AT LOW SPEED (Requires CO ₂ sensor connected)
VENTMAX H		4.4 V	2 to 10Vdc	DCV MAXIMUM DAMPER POSITION AT HIGH SPEED (Requires CO ₂ sensor connected)
VENTMIN L		3.7 V	2 to 10Vdc	DCV MINIMUM DAMPER POSITION AT LOW SPEED (Requires CO ₂ sensor connected)
VENTMIN H		2.8 V	2 to 10Vdc	DCV MINIMUM DAMPER POSITION AT HIGH SPEED (Requires CO ₂ sensor connected)
ERV OAT SP		32°F (0°C)	0 to 50°F; (-18 to 10°C) increment by 1°	ENERGY RECOVERY VENTILATION UNIT OUTDOOR AIR TEMPERATURE SETPOINT Only when AUX1 O = ERV
EXH1 L SET		65%	0 to 100%; increment by 1	EXHAUST FAN STAGE 1 SETPOINT AT LOW SPEED Setpoint for OA damper position when exhaust fan1 is powered by the economizer.
EXH1 H SET		50%	0 to 100%; increment by 1	EXHAUST FAN STAGE 1 SETPOINT AT HIGH SPEED Setpoint for OA damper position when exhaust fan1 is powered by the economizer.
EXH2 L SET		80%	0 to 100%; increment by 1	EXHAUST FAN STAGE 2 SETPOINT AT LOW SPEED Setpoint for OA damper position when exhaust fan 2 is powered by the economizer. Only used when AUX1 -O is set to EHX2.
EXH2 H SET		75%	0 to 100%; increment by 1	EXHAUST FAN STAGE 2 SETPOINT AT HIGH SPEED Setpoint for OA damper position when exhaust fan 2 is powered by the economizer. Only used when AUX1 -O is set to EHX2.

Staged Air Volume (SAV™) with Variable Frequency Drive

The Staged Air Volume (SAV) system utilizes a Variable Frequency Drive (VFD) to automatically adjust the indoor fan motor speed in sequence with the unit's ventilation, cooling and heating operation. Per ASHRAE 90.1-2016 during the first stage of cooling operation the SAV system

will adjust the fan motor to provide 66% of the design airflow rate for the unit. When the call for the second stage of cooling is required, the SAV system will allow the design airflow rate for the unit established (100%). During the heating mode, the SAV system will allow total design airflow rate (100%) operation. During ventilation mode, the SAV system will operate the fan motor at 66% speed.

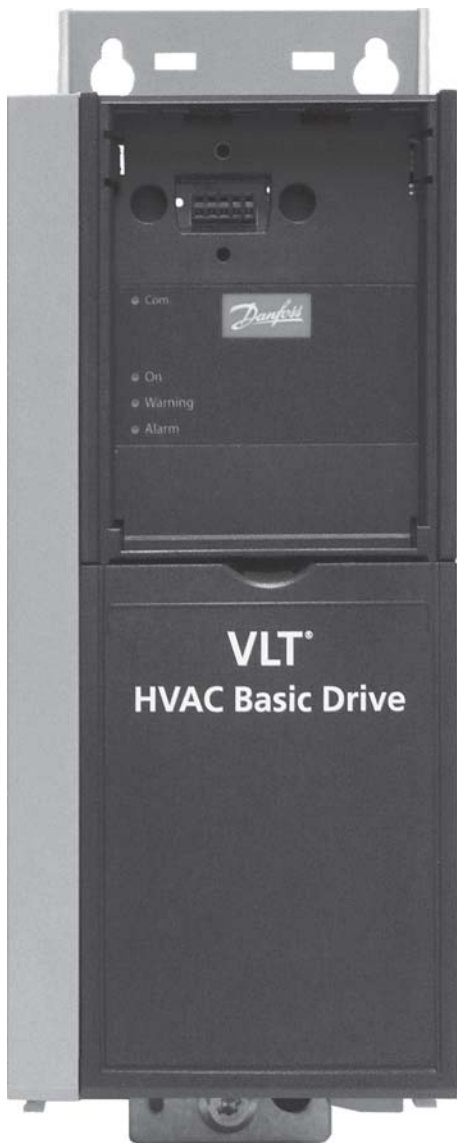

Fig. 58 - Variable Frequency Drive (VFD)

C13110

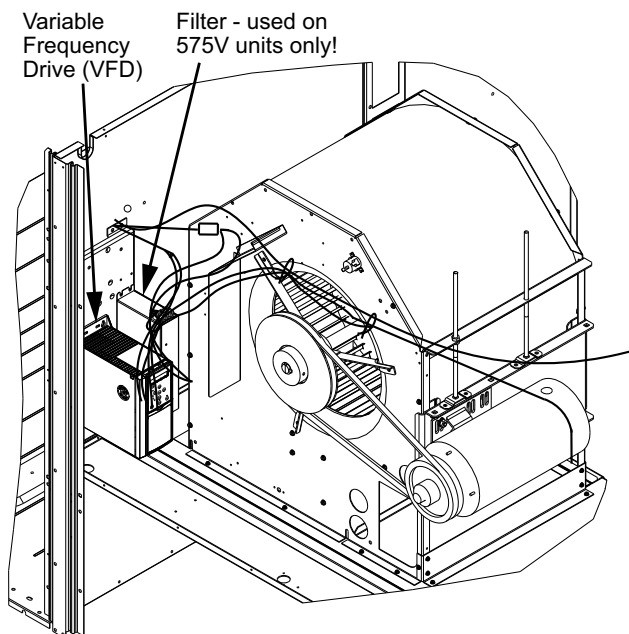

Fig. 59 - VFD Location

C13111

Multi-Speed VFD Display Kit (Field-Installed Accessory)

NOTE: The Remote VFD Keypad is part of the Multi-Speed VFD display kit (PN: CRDISKIT002A00) which is a field-installed accessory. It is not included with the 48LC 07 base unit.

The VFD keypad as shown in Fig. 60 consists of the following sections:

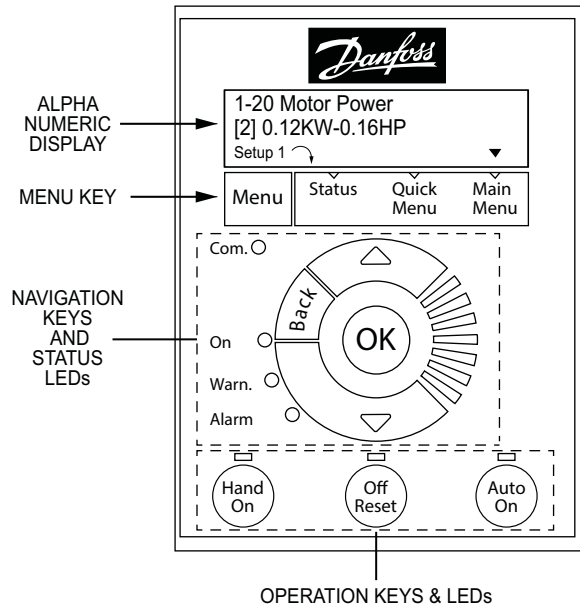

OPERATION KEYS & LEDs

Fig. 60 - VFD Keypad

C13112

Alpha Numeric Display: The LCD display is back lit with 2 alpha-numeric lines. All data is displayed on the LCD.

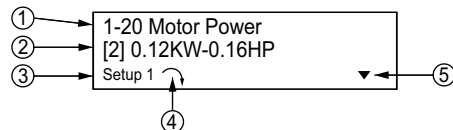

C13113

1	Parameter number and name.
2	Parameter value.
3	Setup number shows the active setup and the edit setup. If the same set-up acts as both the active and edit set-up, only that setup number is shown (factory setting). When the active and edit setup differ, both numbers are shown in the display (SETUP 12). The flashing number indicates the edit setup.
4	The symbol in the number 4 position in the figure above indicates motor direction. The arrow point either clockwise or counter-clockwise to show the motor's current direction.
5	The position of the triangle indicates the currently selected menu: Status, Quick Menu or Main Menu.

Menu Key: Use the Menu key to select between Status, Quick Menu or Main Menu. The triangle icon at the bottom of the LCD display indicates the currently selected mode. (See number 5 in the table above.)

Navigation Keys and Status LEDs: The Navigation keys and Status LEDs are detailed in the following table.

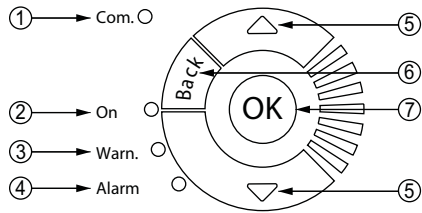

C13114

1	Com. LED: Flashes when bus communications is communicating.
2	Green LED/On: Control selection is working.
3	Yellow LED/Warn.: Indicates a warning.
4	Flashing Red LED/Alarm: Indicates an alarm.
5	Arrows ▲▼: Use the Up and Down arrow keys to navigate between parameter groups, parameters and within parameters. Also used for setting local reference.
6	Back key: Press to move to the previous step or layer in the navigation structure.
7	OK key: Press to select the currently displayed parameter and for accepting changes to parameter settings.

Operation Keys and LEDs: The following table details the functions of the Operating keys. An illuminated yellow LED above the key indicates the active key.

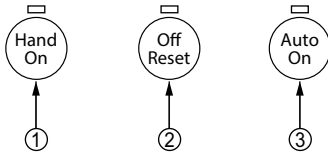

C13115

1	Hand On key: Starts the motor and enables control of the variable frequency drive (VFD) via the VFD Keypad option. NOTE: Please note that terminal 27 Digital Input (5-12 Terminal 27 Digital Input) has coast inverse as default setting. This means that the Hand On key will not start the motor if there is no 24V to terminal 27, so be sure to connect terminal 12 to terminal 27.
2	Off/Reset key: Stops the motor (off). If in alarm mode the alarm will be reset.
3	Auto On key: The variable frequency drive is controlled either via control terminals or serial communication.

Connecting the Keypad to the VFD

The VFD keypad can be mounted directly to the variable frequency drive, provided you can easily access the front panel of the VFD. If you do not have easy access to the VFD front panel, use the cable included with the kit to connect the keypad to the VFD.

Connecting the Keypad Directly to the VFD —

1. Place the bottom of the VFD keypad into the variable frequency drive as shown in Fig. 61.

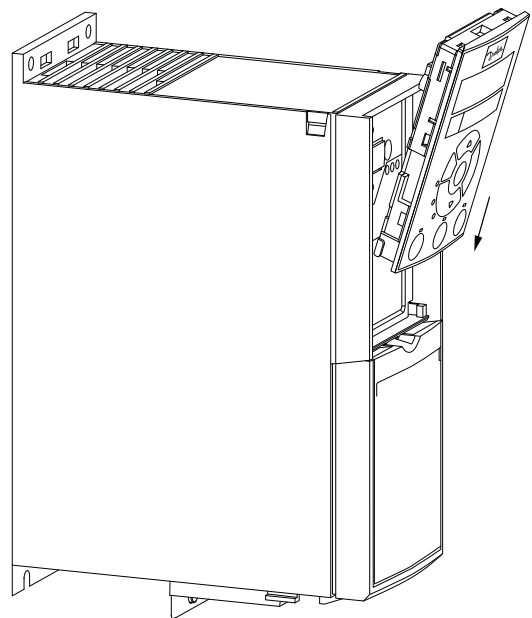

C13116

Fig. 61 - Align Bottom of VFD Keypad with Opening in VFD Front Panel

2. Push the top of the VFD keypad into the variable frequency drive as shown in Fig. 62.

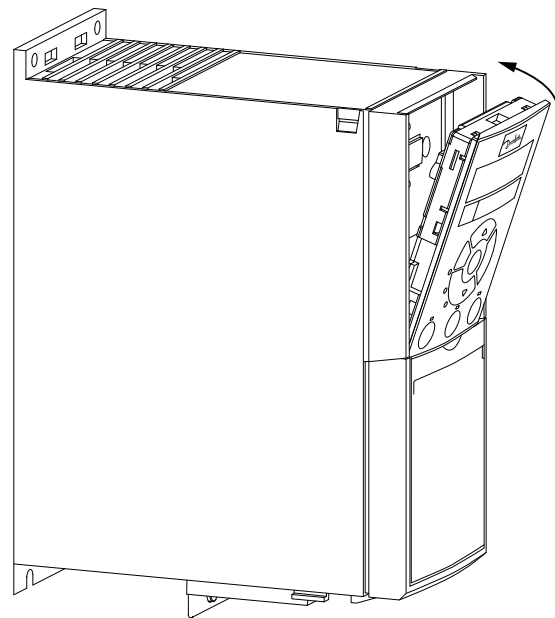

C13117

Fig. 62 - Secure Keypad in Place

Using the Cable to Connect the Keypad to the VFD —

The VFD keypad can be connected to the variable frequency drive via the cable included with the Multi-Speed VFD display kit (PN: CRDISKIT002A00).

1. Connect the male end of the cable to the front panel of the variable frequency drive. Use 2 of the screws included with the kit to secure the cable to the VFD.
2. Connect the female end of the cable to the back panel of the VFD Remote keypad. Secure the cable to the remote keypad using the 2 remaining screws from the kit.

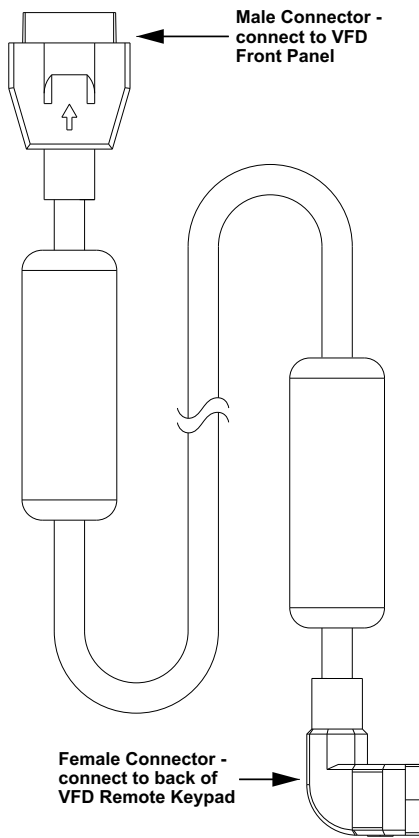

Fig. 63 - VFD Remote Keypad Cable

C13118

Program the VFD for 3 Discrete Indoor Fan Speeds

IMPORTANT: 48LC 07 units are programmed at the factory for 3 discrete indoor fan speeds. The following procedure is only to be used to recover this function after an event such as a system crash.

NOTE: This procedure requires use of the VFD Keypad which is included as part of the field-installed Multi-Speed VFD display kit (PN: CRDISKIT002A00). If the VFD keypad is not already installed, install it. See “Connecting the Keypad to the VFD” for details.

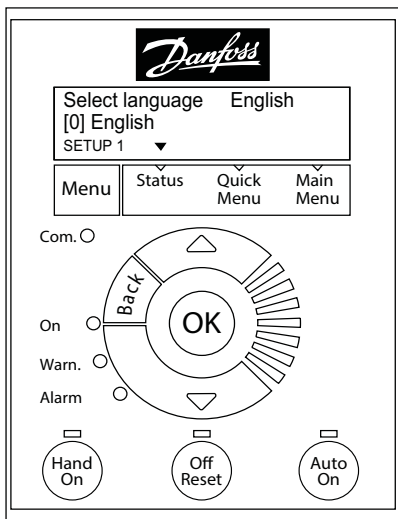

Fig. 64 - Keypad with Power Up Screen Displayed

C13119

To program the VFD for 3 discrete indoor fan motor speeds:

1. At Power-Up:

At the first power up the LCD displays the Select Language screen. The default setting is English. To change the language, press the **OK** key and use the **▲** and **▼** keys to scroll to the desired language and then press **OK**.

2. Selecting Regional Settings:

a. Press the **Off Reset** key.

b. Press the **Menu** key to move the **▼**(triangle icon) so it is positioned over Main Menu. The display show the following -

0- ** Operation / Display
1- ** Load and Motor

c. Press the **OK** key, the display changes to -

0-0* Basic Settings
0-1* Set-up Operations

d. With the top row highlighted, press **OK**. The display changes to -

0-01 Language
[0] English

NOTE: If English is not the desired language press **OK**, select the desired language and press **OK** again.

e. Press **▼**(Down Arrow key) once; the display changes to -

0-03 Regional Settings
[0] International

f. Press **OK**; the [0] is now highlighted.

g. Press **▼**(Down Arrow) key once; the display changes to -

0-03 Regional Settings
[1] North America

h. Press **OK**

NOTE: If the Alarm 060 appears, follow Step 3 to clear the alarm. Make sure to press **Off Reset** when done. If there is no alarm, continue at Step 4.

3. Clearing Alarm 060: External Interlock:

a. Press the **Menu** key twice to position the **▼**(triangle icon) over Main Menu; the display changes to -

0- ** Operation / Display
1- ** Load and Motor

b. Press the **▼**(Down Arrow) key until the following display appears -

4- ** Limits / Warnings
5- ** Digital In/Out

c. Press **OK**. The display changes to -

5-0* Digital I/O mode
5-1* Digital Inputs

- d. Press **▼(Down Arrow)** once to highlight the bottom row and press **OK**. The display changes to -

5-10 Terminal 18 Digital In...
[8] Start

- e. Press **▼(Down Arrow)** twice; the following display appears-

5-12 Terminal 27 Digital In...
[7] External Interlock

- f. Press **OK** to highlight the number in the bracket.
g. Press **▼(Down Arrow)** until the following display appears -

5-12 Terminal 27 Digital In...
[0] No operation

- h. Press **OK**.
i. Press **Off Reset**. The Alarm indicator disappears.

4. Entering Grid Type:

- a. Press the **Menu** key to move the **▼**(triangle icon) so it is positioned over Main Menu. The display show the following -

0-0* Basic Settings
0-1* Set-up Operations

- b. Press **OK** twice: the display changes to -

0-01 Language
[0] English

- c. Press **▼(Down Arrow)** three times, to reach the following display -

0-06 Grid Type
[102] 200-240V/60Hz

- d. Press **OK** to highlight the number in the bracket and then use the **▲** and **▼(Up and Down Arrow)** keys to select the desired voltage and Hertz for the unit.
e. Press **OK** to accept the selection and continue.

5. Entering Motor Data:

- a. Press the **Menu** key to move the **▼**(triangle icon) so it is positioned over Main Menu. The display show the following -

0- ** Operation / Display
1- ** Load and Motor

- b. Press **▼(Down Arrow)** once to highlight the bottom row.

- c. Press **OK**, the display changes to -

1-0* General Settings
1-1* Motor Selection

- d. Press **▼(Down Arrow)** twice to reach the following display -

1-1* Motor Selection
1-2* Motor Data

- e. Press **OK**, the following display appears -

1-20 Motor Power
[9] 1.5kW - 2 hp

NOTE: The number in the bracket may be different from what is shown above.

- f. Press **OK** and then use the **▲** and **▼(Up and Down Arrow)** keys to scroll to the proper motor horsepower. Press **OK** again to set the selected hp.

- g. Press **▼(Down Arrow)** once, the following display appears -

1-22 Motor Voltage
230V

- h. Press **OK** to highlight the voltage value. Use the **▲** and **▼(Up and Down Arrow)** keys to select the nameplate voltage. Press **OK** again to set the selected voltage.

- i. Press **▼(Down Arrow)** once to display the following -

1-23 Motor Frequency
60Hz

- j. Press **OK** to highlight the Frequency value and then use the **▲** and **▼(Up and Down Arrow)** keys to select the nameplate Hz. Press **OK** again to set the selected Hz.

- k. Press **▼(Down Arrow)** once to display the following -

1-24 Motor Current
6.61A

- l. Press **OK** to highlight the Current value and then use the **▲** and **▼(Up and Down Arrow)** keys to select the Max Amps value provided. Press **OK** again to set the selected Max Amps.

NOTE: The Max Amps is greater than the nameplate value. Check the VFD Unit Parameters (see Table 20 on page 62) and use the value listed for the given unit in the column labeled "Motor Current Must-Hold Amps".

- m. Press **▼(Down Arrow)** once to display the following -

1-25 Motor Nominal Speed
1740rpm

- n. Press **OK** to highlight the rpm value and then use the **▲** and **▼(Up and Down Arrow)** keys to select the nameplate rpm. Press **OK** again to set the selected rpm.

6. Entering Parameters for 1-71, 1-73, 1-82, and 1-90:

- a. Press the **Menu** key to move the **▼**(triangle icon) so it is positioned over Main Menu. The display show the following -

0- ** Operation / Display
1- ** Load and Motor

- b. Press **▼(Down Arrow)** once to highlight the bottom row.

c. Press **OK**, the display changes to -

1-0* General Settings
1-1* Motor Selection

d. Press **▼(Down Arrow)** until the following display appears -

1-6* Load Depen. Setting
1-7* Start Adjustments

e. Press **OK**, the following display appears -

1-71 Start Delay
2.0s

f. Press **OK** to highlight the number and then use the **▲** and **▼ (Up and Down Arrow)** keys to select the number provided in Table 20. Press **OK** again to set the selected value.

g. Press **▼(Down Arrow)** twice, the following display appears -

1-73 Flying Start
[1] Enabled

h. Press **OK** to highlight the number in the bracket and then use the **▲** and **▼ (Up and Down Arrow)** keys to select the number provided in Table 20. Press **OK** again to set the selected value.

i. Press the **Back** key once, the following display appears -

1-6* Load Depen. Setting
1-7* Start Adjustments

j. Press **▼(Down Arrow)** once, the following display appears -

1-7* Start Adjustments
1-8* Stop Adjustments

k. Press **OK**, the following display appears -

1-80 Function at Stop
[0] Coast

l. Press **▼(Down Arrow)** once, the following display appears -

1-82 Min Speed for Functio...
1.0 Hz

m. Press **OK** to highlight the number and then use the **▲** and **▼ (Up and Down Arrow)** keys to select the number provided in Table 20. Press **OK** again to set the selected value.

n. Press the **Back** key once, the following display appears -

1-7* Start Adjustments
1-8* Stop Adjustments

o. Press **▼(Down Arrow)** once, the following display appears -

1-8* Stop Adjustments
1-9* Motor Temperature

p. Press **OK**, the following display appears -

1-90 Motor Thermal Prote...
[4] ETR trip 1

q. Press **OK** to highlight the number in the bracket then use the **▲** and **▼ (Up and Down Arrow)** keys to select the number provided in Table 20. Press **OK** again to set the selected value.

7. Setting References:

a. Press the **Menu** key to move the **▼(triangle icon)** so it is positioned over Main Menu. The display show the following -

0- ** Operation / Display
1- ** Load and Motor

b. Press **▼(Down Arrow)** three times, the following display appears -

2- ** Brakes
3- ** Reference / Ramps

c. Press **OK**, the following display appears -

3-0* Reference Limits
3-1* References

d. Press **OK** again, the following display appears -

3-02 Minimum Reference
0.000

NOTE: If the bottom row displays a number other than 0.000, press **OK** and use the **▲** and **▼ (Up and Down Arrow)** key to select 0.000.

e. Press **▼(Down Arrow)** once, the following display appears -

3-03 Maximum Reference
60.000

NOTE: If the bottom row displays a number other than 60.000, press **OK** and use the **▲** and **▼ (Up and Down Arrow)** key to select 60.000.

f. Press the **Back** key until the following display appears -

3-0* Reference Limits
3-1* References

g. Press **▼(Down Arrow)** once to move the highlight to the bottom row and then press **OK**. The following display appears -

3-10 Preset Reference
[0]0.00%

h. Press **OK** once to highlight the number in the bracket. Press **OK** again; the highlight moves to the current percent value.

Use the **▲** and **▼ (Up and Down Arrow)** keys and the following table to enter the required Preset Reference values.

[0]0.00%	Stop
[1]LL.LL%	Low Speed (see Table 20, column labeled "Preset References 3-10[1]" for the proper % for each unit)
[2]MM.MM%	Medium Speed (see Table 20, column labeled "Preset References 3-10[2]" for the proper % for each unit)
[3]100%	Override (High Speed)
[4]100%	High Speed (100% or close to 100% to achieve the required CFM at high speed)
[5]0.00%	Stop
[6]0.00%	Stop
[7]0.00%	Stop

8. Setting the Ramp Time:

- a. Press the **Back** key until the following display appears -

3-0* Reference Limits
3-1* References

- b. Press **▼(Down Arrow)** twice, the following display appears -

3-1* References
3-4* Ramp 1

- c. Press **OK**, the following display appears -

3-41 Ramp 1 Ramp up Time
3.00s

- d. Press **OK** again to highlight the bottom row and use the **▲** and **▼(Up and Down Arrow)** keys to select 10.00s. Press **OK** again to set the selected Ramp up Time.

- e. Press **▼(Down Arrow)** once, the following display appears -

3-42 Ramp 1 Ramp Down Time
3.00s

- f. Press **OK** again to highlight the bottom row and use the **▲** and **▼(Up and Down Arrow)** keys to select 10.00s. Press **OK** again to set the selected Ramp Down Time.

9. Setting Limits:

- a. Press the **Back** key until the following display appears -

2- ** Brakes
3- ** Reference / Ramps

- b. Press **▼(Down Arrow)** once, the following display appears -

3- ** Reference / Ramps
4- ** Limits / Warnings

- c. Press **OK**, the following display appears -

4-1* Motor Limits
4-4* Adj. Warning 2

- d. Press **OK** again, the following display appears -

4-10 Motor Speed Direction
[2] Both Directions

- e. Press **▼(Down Arrow)** once, the following display appears -

4-12 Motor Speed Low Limi...
0.0Hz

- f. Press **▼(Down Arrow)** again, the following display appears -

4-14 Motor Speed High Limi...
65.0Hz

NOTE: Press **OK** to highlight the Hz value and then use the **▲** and **▼(Up and Down Arrow)** keys to enter the required values.

- g. Press **▼(Down Arrow)** once, the following display appears -

4-18 Current Limit
110%

NOTE: Press **OK** to highlight the % value and then use the **▲** and **▼(Up and Down Arrow)** keys to enter the required value. See Table 20 for proper selection of the value for this parameter then press **OK** to set the selected value.

- h. Press **▼(Down Arrow)** once, the following display appears -

4-19 Max Output Frequency
65.0Hz

NOTE: Press **OK** to highlight the Hz value and then use the **▲** and **▼(Up and Down Arrow)** keys to enter the required values.

10. Setting Digital Inputs:

- a. Press the **Back** key until the following display appears -

3- ** Reference / Ramps
4- ** Limits / Warnings

- b. Press **▼(Down Arrow)** once, the following display appears -

4- ** Limits / Warnings
5- ** Digital In/Out

- c. Press **OK**, the following display appears -

5-0* Digital I/O mode
5-1* Digital Inputs

- d. Press **▼(Down Arrow)** once to move the highlight to the bottom row and then press **OK**. The following display appears -

5-10 Terminal 18 Digital In...
[8] Start

- e. Press **▼(Down Arrow)** again. The following display appears -

5-11 Terminal 19 Digital In...
[16] Preset ref bit 0

- f. Press **▼(Down Arrow)** again. The following display appears -

5-12 Terminal 27 Digital In...
[17] Preset ref bit 1

- g. Press **▼(Down Arrow)** again. The following display appears -

5-13 Terminal 29 Digital In...
[18] Preset ref bit 2

NOTE: By pressing **OK** the number in the bracket can be changed until the desired number appears. Press **OK** again to set the selected value.

11. Setting Analog Inputs:

- a. Press the **Back** key until the following display appears -

4- ** Limits / Warnings
5- ** Digital In/Out

- b. Press **▼(Down Arrow)** until the following display appears -

5- ** Digital In/Out
6- ** Analog In/Out

- c. Press **OK**, the following display appears -

6- ** Analog In/Out
6- 1* Analog Input 53

- d. Press **▼(Down Arrow)** once to move the highlight to the bottom row and then press **OK**. The following display appears -

6-10 Terminal 53 Low Voltage
2V

- e. Press **▼(Down Arrow)** once to move the highlight to the bottom row and then press **OK**. The following display appears -

6-11 Terminal 53 High Voltage
[10V]

- f. Press **▼(Down Arrow)** once to move the highlight to the bottom row and then press **OK**. The following display appears -

6-14 Set Min Reference
[0 Hz]

- g. Press **▼(Down Arrow)** once to move the highlight to the bottom row and then press **OK**. The following display appears -

6-15 Set Max Reference
[60 Hz]

12. Setting Reset Mode and RFI Filter:

- a. Press the **Back** key until the following display appears -

0- ** Operation / Display
1- ** Load and Motor

- b. Press **▼(Down Arrow)** until the following display appears -

13- ** Smart Logic
14- ** Special Functions

- c. Press **OK**, the following display appears -

14- 0* Inverter Switching
14- 1* Mains On/Off

- d. Press **▼(Down Arrow)** twice. The following display appears -

14- 1* Mains On/Off
14- 2* Reset Functions

- e. Press **OK**, the following display appears -

14-20 Reset Mode
[0] Manual reset

- f. Press **OK** to highlight the number in the bracket.

- g. Use the **▲** and **▼ (Up and Down Arrow)** keys to change the number to 3 for 3 automatic resets and then press **OK**. The display changes to -

14-20 Reset Mode
[3] Automatic reset x 3

- h. Press **▼(Down Arrow)** once, the following display appears -

14-21 Automatic Restart T...
10s

- i. Press **OK** to highlight the number of seconds and use the **▲** and **▼ (Up and Down Arrow)** keys to select 600 seconds. Press **OK** again to set the selected value.

- j. Press the **Back** key once, the following display appears -

14- 1* Mains On/Off
14- 2* Reset Functions

- k. Press **▼(Down Arrow)** twice, the following display appears -

14- 4* Energy Optimising
14- 5* Environment

- l. Press **OK**, the following display appears -

14-50 RFI Filter
[1] On

- m. Press **OK** to highlight the number in the bracket and use the **▲** and **▼ (Up and Down Arrow)** keys to select [0]. Press **OK** again to set the selected value.

13. To Complete Reprogramming:

- a. Press the **Auto On** key before disconnecting the VFD Remote Keypad from the variable frequency drive.

Table 20 – VFD Unit Parameters - 48LC 07 Units

Voltage	Regional Settings		Motor				Grid Type	Motor Power	Motor Voltage	Motor Frequency (Hz)	Motor Current (Must-Hold Amps)	Motor Nominal Speed (rpm)	Star Delay (Sec)	Flying Start	Min Speed for Function (Hz)	Motor Thermal Protection	Preset Reference		
	Unit Size	Motor Option	Motor P/N	VFD Carrier P/N	VFD Mfr P/N	0-03											0-06	1-20	1-22
208/230V	07	STD	HD56FR233	HK30WA370	131L9795	[1]	[102]	[9]	230	60	5.8	1695	2.0	[1]	1.0	[4]	0%	66.50%	66.50%
460V	07	STD	HD56FR463	HK30WA376	131L9863	[1]	[122]	[9]	460	60	2.9	1690	2.0	[1]	1.0	[4]	0%	66.50%	66.50%
575V	07	STD	HD56FR579	HK30WA382	131N0225	[1]	[132]	[9]	575	60	3.1	1690	2.0	[1]	1.0	[4]	0%	66.50%	66.50%
208/230V	07	MID	HD56FR233	HK30WA370	131L9795	[1]	[102]	[9]	230	60	5.8	1695	2.0	[1]	1.0	[4]	0%	66.50%	66.50%
460V	07	MID	HD56FR463	HK30WA376	131L9863	[1]	[122]	[9]	460	60	2.9	1690	2.0	[1]	1.0	[4]	0%	66.50%	66.50%
575V	07	MID	HD56FR579	HK30WA382	131N0225	[1]	[132]	[9]	575	60	3.1	1690	2.0	[1]	1.0	[4]	0%	66.50%	66.50%
208/230V	07	HIGH	HD58FE654	HK30WA371	131L9796	[1]	[102]	[10]	230	60	9.2	1735	2.0	[1]	1.0	[4]	0%	66.50%	66.50%
460V	07	HIGH	HD58FE654	HK30WA377	131L9864	[1]	[122]	[10]	460	60	4.2	1735	2.0	[1]	1.0	[4]	0%	66.50%	66.50%
575V	07	HIGH	HD58FE577	HK30WA383	131N0227	[1]	[132]	[11]	575	60	4.9	1710	2.0	[1]	1.0	[4]	0%	66.50%	66.50%

Voltage	Unit Size	Motor Option	Preset Reference (cont)							Ramp Up Time (Sec)	Ramp Down Time (Sec)	Current Limit	Terminal 18 Digital Input	Terminal 19 Digital Input	Terminal 27 Digital Input	Terminal 29 Digital Input	Terminal 53 Low Voltage	Terminal 53 High Voltage	Terminal 53 Low Reference	Terminal 53 High Reference	Reset Mode	Auto. Restart Time (S)	RFI Filter
			3-10 [3]	3-10 [4]	3-10 [5]	3-10 [6]	3-10 [7]	4-18	5-10														
208/230V	07	STD	100%	100%	0%	0%	0%	10.00	10.00	100%	[8]	[16]	[17]	[18]	2	[10]	0	[60]	[3]	600	[0]		
460V	07	STD	100%	100%	0%	0%	0%	10.00	10.00	100%	[8]	[16]	[17]	[18]	2	[10]	0	[60]	[3]	600	[0]		
575V	07	STD	100%	100%	0%	0%	0%	10.00	10.00	100%	[8]	[16]	[17]	[18]	2	[10]	0	[60]	[3]	600	[0]		
208/230V	07	MID	100%	100%	0%	0%	0%	10.00	10.00	100%	[8]	[16]	[17]	[18]	2	[10]	0	[60]	[3]	600	[0]		
460V	07	MID	100%	100%	0%	0%	0%	10.00	10.00	100%	[8]	[16]	[17]	[18]	2	[10]	0	[60]	[3]	600	[0]		
575V	07	MID	100%	100%	0%	0%	0%	10.00	10.00	100%	[8]	[16]	[17]	[18]	2	[10]	0	[60]	[3]	600	[0]		
208/230V	07	HIGH	100%	100%	0%	0%	0%	10.00	10.00	100%	[8]	[16]	[17]	[18]	2	[10]	0	[60]	[3]	600	[0]		
460V	07	HIGH	100%	100%	0%	0%	0%	10.00	10.00	100%	[8]	[16]	[17]	[18]	2	[10]	0	[60]	[3]	600	[0]		
575V	07	HIGH	100%	100%	0%	0%	0%	10.00	10.00	100%	[8]	[16]	[17]	[18]	2	[10]	0	[60]	[3]	600	[0]		

Table 21 – Unit Wire/Fuse or HACR Breaker Sizing Data

48LC UNIT	NOM. V-Ph-Hz	IFM TYPE	NO C.O. or UNPWR C.O.						w/ PWRD C.O.										
			NO PE.			w/ PE. (pwrd fr/ unit)			NO PE.			w/ PE. (pwrd fr/ unit)							
			MCA	MAX FUSE or HACR BRKR	DISC. SIZE FLA LRA	MCA	MAX FUSE or HACR BRKR	DISC. SIZE FLA LRA	MCA	MAX FUSE or HACR BRKR	DISC. SIZE FLA LRA	MCA	MAX FUSE or HACR BRKR	DISC. SIZE FLA LRA					
07	208/ 230-3-60	STD	35/34	45/45	36/35	173	38/38	50/50	40/40	40/40	177	39/39	50/50	41/41	178	43/43	50/50	45/45	182
		MED	35/34	45/45	36/35	173	38/38	50/50	40/40	40/40	177	39/39	50/50	41/41	178	43/43	50/50	45/45	182
		HIGH	37/37	50/45	39/38	203	41/40	203	50/50	43/42	207	42/41	50/50	44/43	208	46/45	50/50	49/48	212
	460-3-60	STD	20	25	20	87	21	25	22	22	89	22	25	23	89	24	25	25	91
		MED	20	25	20	87	21	25	22	22	89	22	25	23	89	24	25	25	91
		HIGH	20	25	21	103	22	25	23	23	105	23	25	24	105	24	30	26	107
575-3-60	STD	15	20	16	67	19	20	20	20	71	17	20	18	69	21	25	22	73	
	MED	15	20	16	67	19	20	20	20	71	17	20	18	69	21	25	22	73	
	HIGH	17	20	18	80	21	25	22	22	84	19	20	20	82	23	25	24	86	

See "Legend and Notes for Tables 21 and 22" on page 64.

Table 22 – Unit Wire Sizing Data with Factory-Installed HACR Breaker

48LC UNIT	NOM. V-Ph-Hz	IFM TYPE	NO C.O. or UNPWR C.O.						w/ PWRD C.O.										
			NO PE.			w/ PE. (pwrd fr/ unit)			NO PE.			w/ PE. (pwrd fr/ unit)							
			MCA	HACR BRKR	DISC. SIZE FLA LRA	MCA	HACR BRKR	DISC. SIZE FLA LRA	MCA	HACR BRKR	DISC. SIZE FLA LRA	MCA	HACR BRKR	DISC. SIZE FLA LRA					
07	208/ 230-3-60	STD	35/35	45/45	36/35	173	38/38	50/50	40/40	40/40	177	39/39	50/50	41/41	178	43/43	50/50	45/45	182
		MED	35/35	45/45	36/35	173	38/38	50/50	40/40	40/40	177	39/39	50/50	41/41	178	43/43	50/50	45/45	182
		HIGH	37/37	50/50	39/38	203	41/41	203	50/50	43/42	207	42/42	50/50	44/43	208	46/46	50/50	49/48	212
	460-3-60	STD	20	25	20	87	21	25	22	22	89	22	25	23	89	24	25	25	91
		MED	20	25	20	87	21	25	22	22	89	22	25	23	89	24	25	25	91
		HIGH	20	25	21	103	22	25	23	23	105	23	25	24	105	24	30	26	107
575-3-60	STD	15	20	16	67	19	20	20	20	71	17	20	18	69	21	25	22	73	
	MED	15	20	16	67	19	20	20	20	71	17	20	18	69	21	25	22	73	
	HIGH	17	20	18	80	21	25	22	22	84	19	20	20	82	23	25	24	86	

See "Legend and Notes for Tables 21 and 22" on page 64.

Legend and Notes for Tables 21 and 22

LEGEND:

BRKR	-	Circuit breaker
C.O.	-	Convenience outlet
DISC.	-	Disconnect
FLA	-	Full load amps
LRA	-	Locked rotor amps
MCA	-	Minimum circuit amps
P.E.	-	Power exhaust
Pwr'd fr/ unit	-	Powered from unit
PWRD C.O.	-	Powered convenience outlet
UNPWR C.O.	-	Unpowered convenience outlet

NOTES:

- In compliance with NEC requirements for multimotor and combination load equipment (refer to NEC Articles 430 and 440), the overcurrent protective device for the unit shall be fuse or HACR breaker. Canadian units may be fuse or circuit breaker.
- For 208/230 v units, where one value is shown it is the same for either 208 or 230 volts.
- Unbalanced 3-Phase Supply Voltage**
Never operate a motor where a phase imbalance in supply voltage is greater than 2%. Use the following formula to determine the percentage of voltage imbalance.

$$\% \text{ Voltage Imbalance} = 100 \times \frac{\text{max voltage deviation from average voltage}}{\text{average voltage}}$$

Example: Supply voltage is 230-3-60



$$\begin{aligned} AB &= 224 \text{ v} \\ BC &= 231 \text{ v} \\ AC &= 226 \text{ v} \end{aligned}$$

$$\begin{aligned} \text{Average Voltage} &= \frac{(224 + 231 + 226)}{3} = \frac{681}{3} \\ &= 227 \end{aligned}$$

Determine maximum deviation from average voltage.

$$(AB) 227 - 224 = 3 \text{ v}$$

$$(BC) 231 - 227 = 4 \text{ v}$$

$$(AC) 227 - 226 = 1 \text{ v}$$

Maximum deviation is 4 v.

Determine percent of voltage imbalance.

$$\begin{aligned} \% \text{ Voltage Imbalance} &= 100 \times \frac{4}{227} \\ &= 1.76\% \end{aligned}$$

This amount of phase imbalance is satisfactory as it is below the maximum allowable 2%.

IMPORTANT: If the supply voltage phase imbalance is more than 2%, contact your local electric utility company immediately.

Smoke Detectors

Smoke detectors are available as factory-installed options on 48LC models. Smoke detectors may be specified for Supply Air only or for Return Air without or with economizer or in combination of Supply Air and Return Air. All components necessary for operation are factory-provided and mounted. The unit is factory-configured for immediate smoke detector shutdown operation; additional wiring or modifications to

the Integrated Staging Control (ISC) board may be necessary to complete the unit and smoke detector configuration to meet project requirements.

Units equipped with factory-optional Return Air smoke detectors require a relocation of the sensor module at unit installation. See Fig. 65 for the as shipped location.

Completing Installation of Return Air Smoke Sensor:

- Unscrew the two screws holding the Return Air Smoke Detector assembly. See Fig. 66, Step 1. Save the screws.
- Turn the assembly 90 degrees and then rotate end to end. Make sure that the elbow fitting is pointing down. See Fig. 66, Step 2.
- Screw the sensor and detector plate into its operating position using screws from Step 1. See Fig. 66, Step 3.
- Connect the flexible tube on the sampling inlet to the sampling tube on the base pan.

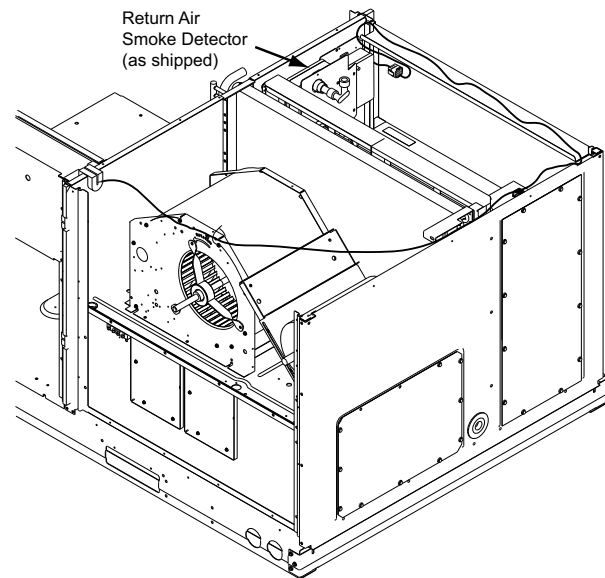

C12282

Fig. 65 - Return Air Smoke Detector, Shipping Position

Additional Application Data —

Refer to *Factory Installed Smoke Detectors for Small and Medium Rooftop Units 2 to 25 Tons* for discussions on additional control features of these smoke detectors including multiple unit coordination.

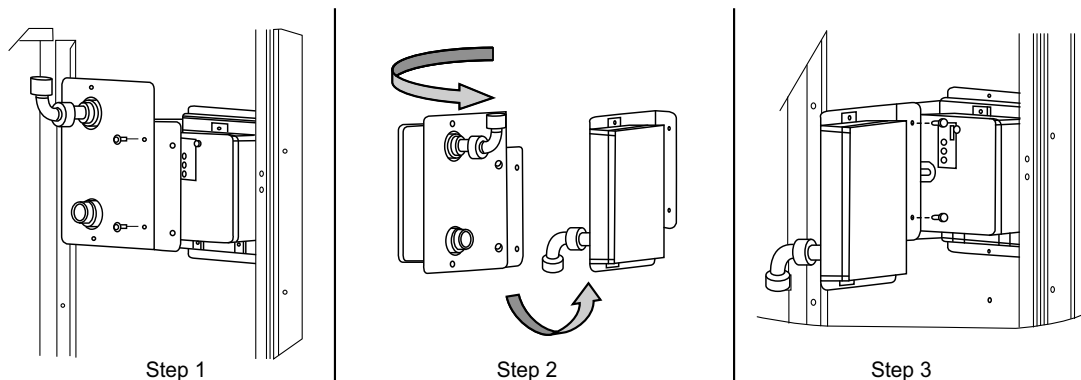

Fig. 66 - Completing Installation of Return Air Smoke Sensor

C12283

Step 13 — Adjust Factory-Installed Options

Smoke Detectors —

Smoke detector(s) will be connected at the Integrated Staging Control (ISC) board, at terminals marked “Smoke Shutdown”. Remove jumper JMP 3 when ready to energize unit.

Step 14 — Install Accessories

Available field-installed accessories include:

- Roof Curb (must be installed before unit)
- Thru-base connection kit (must be installed before unit is set on curb)
- EconoMi\$er[®] X (with control)
- Power Exhaust
- Outdoor enthalpy sensor
- Differential enthalpy sensor
- CO₂ sensor
- Temperature and Humidity sensors
- Louvered hail guard
- Phase monitor control

Refer to separate installation instructions for information on installing these accessories. See Price Pages for a complete list of field-installed accessories.

Step 15 — Check Belt Tension

Measure the belt span length as shown in Fig. 67. Calculate the required deflection by multiplying the belt span length by 1/64. For example, if the belt span length is 32 inches: $32 \times 1/64 = 1/2$ inch deflection.

Belt Force - Deflection Method -

Check the belt tension with a spring-force belt force deflection gauge.

1. Place a straightedge along the belt between the two pulleys. Measure the distance between the motor shaft and the blower shaft.
2. Set the tension gauge to the desired tension (see Table 1 in Fig. 67). Place the large O-ring at that point.
3. Press the tension checker downward on the belt until the large O-ring is at the bottom of the straightedge.
4. Adjust the belt tension as needed.

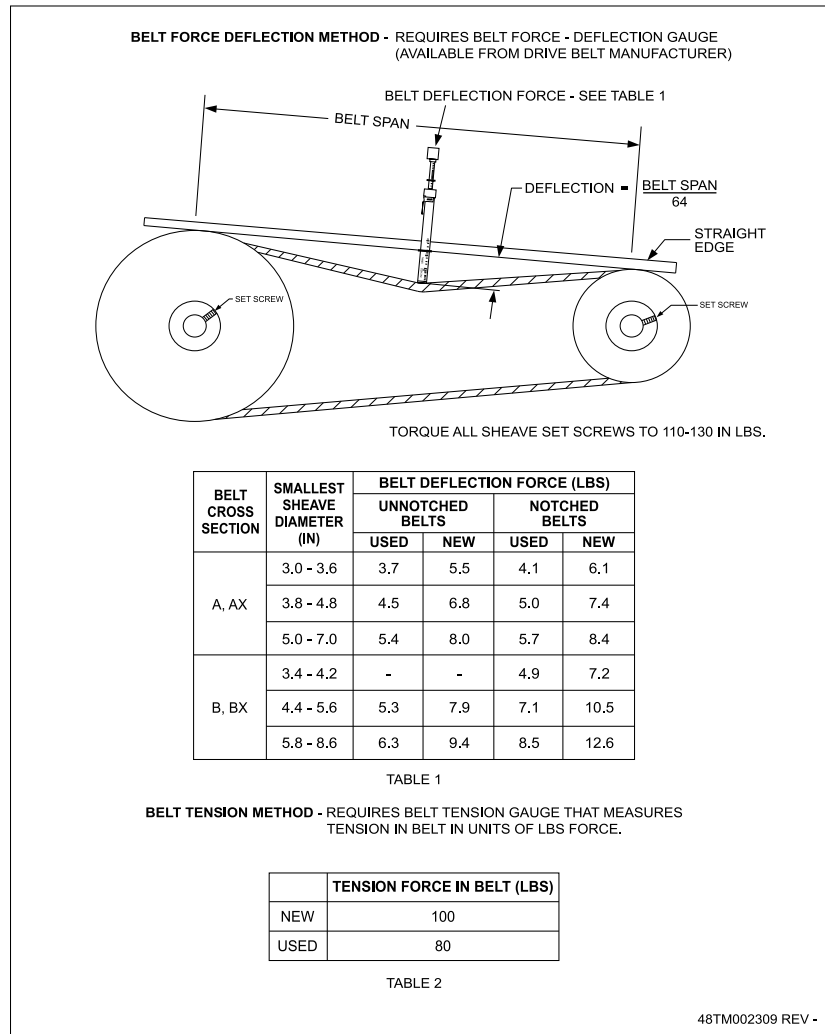
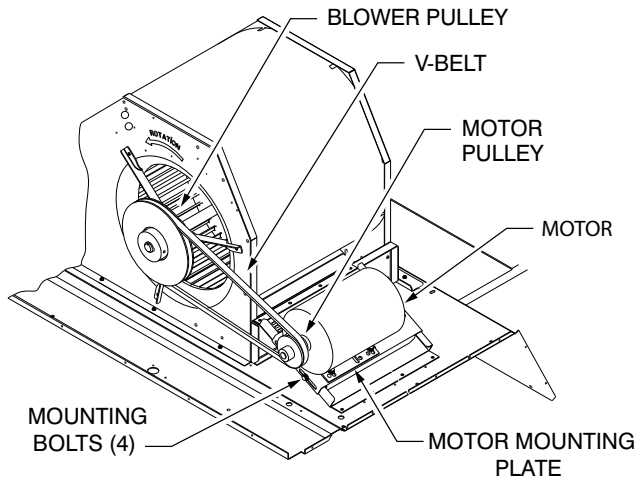

Fig. 67 - V-Belt Force Label

Adjust belt tension by loosening the motor mounting plate front bolts and rear bolt (see Fig. 68) and sliding the plate towards the fan (to reduce tension) or away from the fan (to increase tension). Ensure the blower shaft and motor shaft are parallel to each other (pulleys aligned). Tighten all bolts securely when finished.

Pre-Start and Start-Up —

This completes the mechanical installation of the unit. Refer to the unit's Service Manual for detailed Pre-Start and Start-Up instructions. Download the latest versions from HVAC Partners (www.hvacpartners.com).



C11504

Fig. 68 - Belt Drive Motor Mounting

UNIT START-UP CHECKLIST

(Remove and Store in Job File)

NOTE: To avoid injury to personnel and damage to equipment or property when completing the procedures listed in this start-up checklist, use good judgement, follow safe practices, and adhere to the safety considerations/information as outlined in the preceding sections of this Installation Instructions document.

MODEL NO.: _____

SERIAL NO.: _____

I. PRE-START-UP

- VERIFY THAT ALL PACKAGING MATERIALS HAVE BEEN REMOVED FROM UNIT
- VERIFY INSTALLATION OF OUTDOOR AIR HOOD
- VERIFY INSTALLATION OF FLUE EXHAUST AND INLET HOOD
- VERIFY THAT CONDENSATE CONNECTION IS INSTALLED PER INSTRUCTIONS
- VERIFY THAT ALL ELECTRICAL CONNECTIONS AND TERMINALS ARE TIGHT
- VERIFY GAS PRESSURE TO UNIT GAS VALVE IS WITHIN SPECIFIED RANGE
- CHECK GAS PIPING FOR LEAKS
- CHECK THAT INDOOR-AIR FILTERS ARE CLEAN AND IN PLACE
- CHECK THAT OUTDOOR AIR INLET SCREENS ARE IN PLACE
- VERIFY THAT UNIT IS LEVEL
- CHECK FAN WHEELS AND PROPELLER FOR LOCATION IN HOUSING/ORIFICE AND VERIFY SETSCREW IS TIGHT
- VERIFY THAT FAN SHEAVES ARE ALIGNED AND BELTS ARE PROPERLY TENSIONED
- VERIFY THAT SCROLL COMPRESSORS ARE ROTATING IN THE CORRECT DIRECTION
- VERIFY INSTALLATION OF THERMOSTAT
- VERIFY THAT CRANKCASE HEATERS HAVE BEEN ENERGIZED FOR AT LEAST 24 HOURS

II. START-UP

ELECTRICAL

SUPPLY VOLTAGE	L1-L2	_____	L2-L3	_____	L3-L1	_____
COMPRESSOR AMPS 1	L1	_____	L2	_____	L3	_____
COMPRESSOR AMPS 2	L1	_____	L2	_____	L3	_____
SUPPLY FAN AMPS	L1	_____	L2	_____	L3	_____

TEMPERATURES

OUTDOOR-AIR TEMPERATURE _____ °F DB (DRY BULB)

RETURN-AIR TEMPERATURE _____ °F DB _____ °F WB (WET BULB)

COOLING SUPPLY AIR TEMPERATURE _____ °F

GAS HEAT SUPPLY AIR _____ °F

PRESSURES

GAS INLET PRESSURE _____ IN. WG

GAS MANIFOLD PRESSURE STAGE 1 _____ IN. WG

STAGE 2 _____ IN. WG

REFRIGERANT SUCTION CIRCUIT A _____ PSIG

CIRCUIT B _____ PSIG

REFRIGERANT DISCHARGE CIRCUIT A _____ PSIG

CIRCUIT B _____ PSIG

- VERIFY REFRIGERANT CHARGE USING CHARGING CHARTS

GENERAL

- ECONOMIZER MINIMUM VENT AND CHANGEOVER SETTINGS TO JOB REQUIREMENTS (IF EQUIPPED)
- VERIFY SMOKE DETECTOR UNIT SHUTDOWN BY UTILIZING MAGNET TEST

III. HUMIDI-MIZER[®] SYSTEM START-UP

NOTE: Units equipped with either SystemVu™ or RTU-Open controls have Service Test menus or modes that can assist with the Humidi-MiZer System Start-Up function and provide the means to make the observations listed for this start-up.

STEPS

- 1. CHECK CTB FOR JUMPER 5, 6, 7
JUMPER 5, 6, 7 MUST BE CUT AND OPEN
- 2. OPEN HUMIDISTAT CONTACTS
- 3. START UNIT IN COOLING (CLOSE Y1)

OBSERVE AND RECORD

- A. SUCTION PRESSURE _____ PSIG
- B. DISCHARGE PRESSURE _____ PSIG
- C. ENTERING AIR TEMPERATURE _____ °F
- D. LIQUID LINE TEMPERATURE
AT OUTLET OR REHEAT COIL _____ °F
- E. CONFIRM CORRECT ROTATION FOR COMPRESSOR
- F. CHECK FOR CORRECT RAMP-UP OF OUTDOOR FAN MOTOR AS CONDENSER COIL WARMS
- 4. CHECK UNIT CHARGE PER CHARGING CHART
- 5. SWITCH UNIT TO HIGH-LATENT MODE (SUBCOOLER) BY CLOSING HUMIDISTAT WITH Y1 CLOSED

OBSERVE

- A. REDUCTION IN SUCTION PRESSURE (5 TO 7 PSI EXPECTED)
- B. DISCHARGE PRESSURE UNCHANGED
- C. LIQUID TEMPERATURE DROPS TO 50 TO 55°F RANGE
- D. LSV SOLENOID ENERGIZED (VALVE CLOSSES)
- 6. SWITCH UNIT TO DEHUMID (REHEAT) BY OPENING Y1

OBSERVE

- A. SUCTION PRESSURE INCREASES TO NORMAL COOLING LEVEL
- B. DISCHARGE PRESSURE DECREASES (35 TO 50 PSI)
- C. LIQUID TEMPERATURE RETURNS TO NORMAL COOLING LEVEL
- D. LIQUID SOLENOID VALVE (LSV) ENERGIZED (VALVE CLOSSES)
- E. DISCHARGE SOLENOID VALVE (DSV) ENERGIZED, VALVE OPENS
- 7. WITH UNIT IN DEHUMID MODE CLOSE W1
COMPRESSOR AND OUTDOOR FAN STOP; LSV AND DSV SOLENOIDS DE-ENERGIZED
- 8. OPEN W1 RESTORE UNIT TO DEHUMID MODE
- 9. OPEN HUMIDISTAT INPUT
COMPRESSOR AND OUTDOOR FAN STOP; LSV AND DSV SOLENOIDS DE-ENERGIZED
- 10. RESTORE SETPOINTS FOR THERMOSTAT AND HUMIDISTAT

REPEAT PROCESS FOR 2 COMPRESSOR SYSTEMS