



# Single Package Rooftop with Gas Heat/Electric Cooling Horizontal Air Flow Unit with Puron® (R-410A) Refrigerant

## Installation Instructions

48TC units for installation in the United States contain use of Carrier's Staged Air Volume (SAV™) 2-speed indoor fan control system. This complies with the U.S. Department of Energy (DOE) efficiency standard of 2018.

48TC units for installation outside the United States may or may not contain use of the SAV 2-speed indoor fan control system as they are not required to comply with the U.S. Department of Energy (DOE) efficiency standard of 2018.

For specific details on operation of the Carrier SAV 2-speed indoor fan system refer to the Variable Frequency Drive (VFD) Factory-Installed Option 2-Speed Motor Control Installation, Setup, and Troubleshooting manual.

### CONTENTS

	Page
<b>SAFETY CONSIDERATIONS</b> .....	1
<b>GENERAL</b> .....	2
<b>INSTALLATION</b> .....	10
Job-Site Survey .....	10
Step 1 — Plan for Unit Location .....	11
Step 2 — Plan for Sequence of Unit Installation .....	11
Step 3 — Inspect Unit .....	11
Step 4 — Provide Unit Support .....	11
Step 5 — Rig and Place Unit .....	12
Step 6 — Field Fabricate Ductwork .....	16
Step 7 — Horizontal Duct Connection .....	16
Step 8 — Install Outside Air Hood (Factory- Option) .....	16
Step 9 — Install Flue Hood and Combustion Air Hood .....	17
Step 10 — Install Gas Piping .....	17
Step 11 — Install External Condensate Trap and Line .....	19
Step 12 — Make Electrical Connections .....	20
Humidi-MiZer® Control Connections .....	24
Staged Air Volume (SAV) with Variable Frequency Drive (Factory-Installed Option) .....	26
EconoMiSer® X (Factory-Installed Option) .....	26
PremierLink™ Controller (Factory-Option) .....	40
Field Connections .....	44
Economizer Controls .....	47
RTU Open Control System .....	51
Communication Wiring Protocols .....	57
Local Access .....	58
Outdoor Air Enthalpy Control (P/N 33CENTHSW) .....	59
Smoke Detectors .....	59
Step 13 — Adjust Factory-Installed Options .....	61
Step 14 — Install Accessories .....	61
Step 15 — Check Belt Tension .....	61
Pre-Start and Start-Up .....	62
<b>START-UP CHECKLIST</b> .....	CL-1, CL-2

### SAFETY CONSIDERATIONS

Improper installation, adjustment, alteration, service, maintenance, or use can cause explosion, fire, electrical shock or other conditions which may cause personal injury or property damage. Consult a qualified installer, service agency, or your

distributor or branch for information or assistance. The qualified installer or agency must use factory-authorized kits or accessories when modifying this product. Refer to the individual instructions packaged with the kits or accessories when installing.

Follow all safety codes. Wear safety glasses and work gloves. Use quenching cloths for brazing operations and have a fire extinguisher available. Read these instructions thoroughly and follow all warnings or cautions attached to the unit. Consult local building codes and appropriate national electrical codes (in USA, ANSI/NFPA70, National Electrical Code (NEC); in Canada, CSA C22.1) for special requirements.

It is important to recognize safety information. This is the safety-alert symbol . When you see this symbol on the unit and in instructions or manuals, be alert to the potential for personal injury.

Understand the signal words DANGER, WARNING, CAUTION, and NOTE. These words are used with the safety-alert symbol. DANGER identifies the most serious hazards which will result in severe personal injury or death. WARNING signifies hazards which could result in personal injury or death. CAUTION is used to identify unsafe practices, which may result in minor personal injury or product and property damage. NOTE is used to highlight suggestions which will result in enhanced installation, reliability, or operation.

**WARNING**

Failure to follow this warning could result in personal injury or death. Disconnect gas piping from unit when leak testing at pressure greater than 0.5 psig (3450 Pa). Pressures greater than 0.5 psig (3450 Pa) will cause gas valve damage resulting in hazardous condition. If gas valve is subjected to pressure greater than 0.5 psig (3450 Pa), it must be replaced before use. When pressure testing field-supplied gas piping at pressures of 0.5 psig (3450 Pa) or less, a unit connected to such piping must be isolated by closing the manual gas valve.

**WARNING**

Failure to follow this warning could cause personal injury or death. Before performing service or maintenance operations on unit, always turn off main power switch to unit and install lock(s) and lockout tag(s). Unit may have more than one power switch.

**⚠ WARNING**

Failure to follow this warning could cause personal injury, death and/or equipment damage.

Puron® (R-410A) refrigerant systems operate at higher pressures than standard R-22 systems. Do not use R-22 service equipment or components on Puron refrigerant equipment.

**⚠ WARNING**

Failure to follow this warning could cause personal injury or death.

Relieve pressure and recover all refrigerant before system repair or final unit disposal.

Wear safety glasses and gloves when handling refrigerants. Keep torches and other ignition sources away from refrigerants and oils.

**⚠ CAUTION**

Failure to follow this caution may result in personal injury.

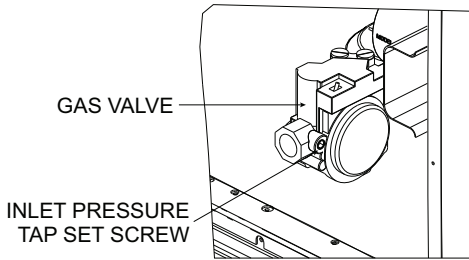
Sheet metal parts may have sharp edges or burrs. Use care and wear appropriate protective clothing, safety glasses and gloves when handling parts and servicing air conditioning equipment.

**⚠ WARNING**

**FIRE HAZARD**

Failure to follow this warning could result in personal injury, death, and/or property damage.

Inlet pressure tap set screw must be tightened and 1/8 in. NPT pipe plug must be installed to prevent gas leaks.

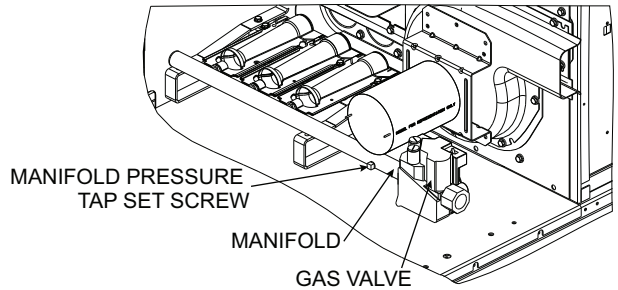


**⚠ WARNING**

**FIRE HAZARD**

Failure to follow this warning could result in personal injury, death, and/or property damage.

Manifold pressure tap set screw must be tightened and 1/8 in. NPT pipe plug must be installed to prevent gas leaks.



**⚠ WARNING**

**CARBON-MONOXIDE POISONING HAZARD**

Failure to follow instructions could result in severe personal injury or death due to carbon-monoxide poisoning, if combustion products infiltrate into the building.

Check that all openings in the outside wall around the vent (and air intake) pipe(s) are sealed to prevent infiltration of combustion products into the building.

Check that furnace vent (and air intake) terminal(s) are not obstructed in any way during all seasons.

**GENERAL**

These installation instructions cover the 48TC units with gas heat and electric cooling. Units are pre-wired and pre-charged with environmentally sound Puron® (R-410A) refrigerant at the factory. See Fig. 1 for model number nomenclature. See Fig. 2-4 for unit dimensions. See Fig. 5 for service clearances.

**Rated Indoor Airflow (cfm)** — Table 1 lists the rated indoor airflow used for the AHRI efficiency rating for the units covered in this document.

**Table 1 — AHRI Efficiency — Rated Indoor Airflow**

MODEL NUMBER	FULL LOAD AIRFLOW (CFM)
48TC*D/E18	4900
48TC*D/E21	5700
48TC*D/E25	6500
48TC*D/E29	8125

Position:	1	2	3	4	5	6	7	8	9	10	11	12	13	14	15	16	17	18
Example:	4	8	T	C	D	D	2	5	A	5	A	5	-	0	A	0	A	0

**Unit Heat Type**  
48 - Gas Heat Packaged Rooftop

**Model Series - WeatherMaker®**  
TC - Standard Efficiency

**Heat Options**  
D = Low Gas Heat  
E = Medium Gas Heat  
F = High Gas Heat  
S = Low Heat w/ Stainless Steel Exchanger  
R = Medium Heat w/ Stainless Steel Exchanger  
T = High Heat w/ Stainless Steel Exchanger

**Refrig. Systems Options**  
D = Two stage cooling model  
E = Two stage cooling models with Humidi-MiZer® System

**Cooling Tons (Horizontal Air Flow)**  
18 = 15 tons  
21 = 17.5 tons  
25 = 20 tons  
29 = 25 tons

**Sensor Options**  
A = None  
B = RA Smoke Detector  
C = SA Smoke Detector  
D = RA + SA Smoke Detector  
E = CO<sub>2</sub>  
F = RA Smoke Detector and CO<sub>2</sub>  
G = SA Smoke Detector and CO<sub>2</sub>  
H = RA + SA Smoke Detector and CO<sub>2</sub>  
J = Condensate Overflow Switch  
K = Condensate Overflow Switch and RA Smoke Detectors  
L = Condensate Overflow Switch and RA and SA Smoke Detectors

**Indoor Fan Options & Air Flow Configuration**  
5 = Standard Static/Horizontal Supply, Return Air Flow (except 29 size models)  
6 = Medium Static/Horizontal Supply, Return Air Flow (Standard on 29 size models)  
7 = High Static/Horizontal Supply, Return Air Flow  
F = Medium Static, High Efficiency Motor/Horizontal Supply, Return Air Flow  
G = High Static, High Efficiency Motor/Horizontal Supply, Return Air Flow

**NOTE:**  
Not all possible options are displayed. See the current 48TC Horizontal 15 to 25 Ton Price Pages for more details.

**Packaging**  
0 = Standard

**Electrical Options**  
A = None  
C = Non-Fused Disconnect  
G = 2-Speed Indoor Fan (VFD) Controller  
J = 2 Speed Fan Controller (VFD) & Non-Fused Disconnect

**Service Options**  
0 = None  
1 = Unpowered Convenience Outlet  
2 = Powered Convenience Outlet  
3 = Hinged Panels  
4 = Hinged Panels & Unpowered Convenience Outlet  
5 = Hinged Panels & Powered Convenience Outlet

**Intake / Exhaust Options**  
A = None  
B = Temperature Economizer w/ Barometric Relief  
F = Enthalpy Economizer w/ Barometric Relief  
K = 2-Position Damper  
P = Manual Outdoor Air Damper  
U = Temp Ultra Low Leak Economizer w/ Barometric Relief  
W = Enthalpy Ultra Low Leak Economizer w/ Barometric Relief

**Base Unit Controls**  
0 = Electro-mechanical Controls. Can be used with W7212 EconoMiSer IV (Non-Fault Detection and Diagnostic)  
1 = PremierLink™ Controller  
2 = RTU Open Multi-Protocol Controller  
6 = Electro-mechanical w/ 2-Speed Fan and W7220 Economizer Controller. Can be used with W7220 EconoMiSer X (with Fault Detection and Diagnostic)

**Design Revision**  
- = Factory Design Revision

**Voltage**  
1 = 575/3/60  
5 = 208-230/3/60  
6 = 460/3/60

**Coil Options – RTPF (Outdoor - Indoor - Hail Guard)**  
A = Al/Cu - Al/Cu  
B = Precoat Al/Cu - Al/Cu  
C = E-coat Al/Cu - Al/Cu  
D = E-coat Al/Cu - E-coat Al/Cu  
E = Cu/Cu - Al/Cu  
F = Cu/Cu - Cu/Cu  
M = Al/Cu -Al/Cu — Louvered Hail Guard  
N = Precoat Al/Cu - Al/Cu — Louvered Hail Guard  
P = E-coat Al/Cu - Al/Cu — Louvered Hail Guard  
Q = E-coat Al/Cu - E-coat Al/Cu — Louvered Hail Guard  
R = Cu/Cu - Al/Cu — Louvered Hail Guard  
S = Cu/Cu - Cu/Cu — Louvered Hail Guard

**Fig. 1 — 48TC MRT Horizontal Airflow Units Model Number Nomenclature (Example)**

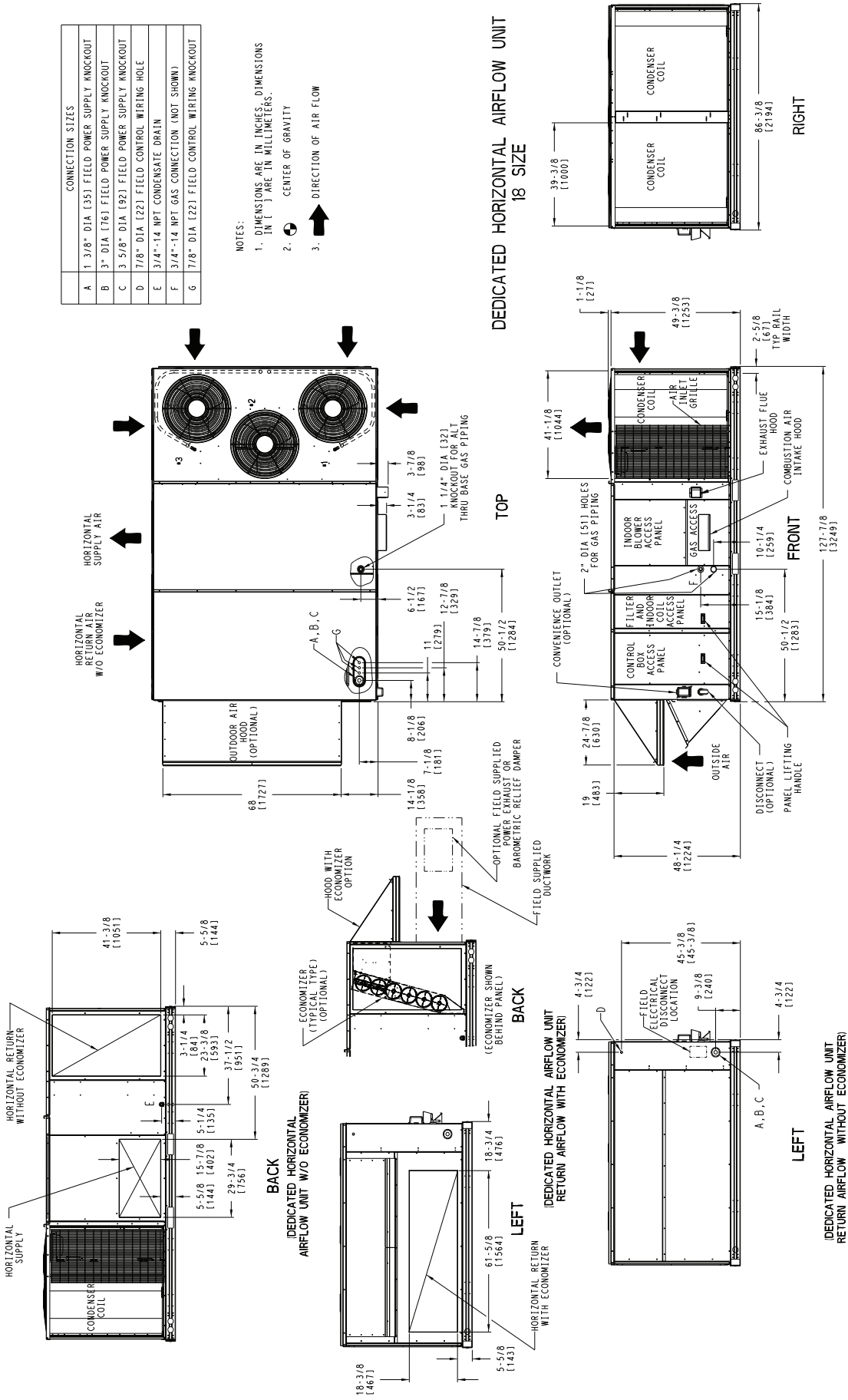


Fig. 2 — Unit Dimensional Drawing — 18 Size Unit



UNIT	OUTDOOR COIL TYPE	STD UNIT WEIGHT *		CORNER WEIGHT (A)		CORNER WEIGHT (B)		CORNER WEIGHT (C)		CORNER WEIGHT (D)		C.G.					
		LBS.	KG.	LBS.	KG.	LBS.	KG.	LBS.	KG.	LBS.	KG.	X	Y	Z			
48TC18	RTPF	1892	860	401	182	449	204	565	257	505	230	48	1219	67 3/8	1711	16 1/2	419
RTPF - ROUND TUBE, PLATE FIN (COPPER/ALUM) MCHX - NOVATION (ALUM/ALUM)																	

\* STANDARD UNIT WEIGHT IS WITH LOW GAS HEAT AND WITHOUT PACKAGING.

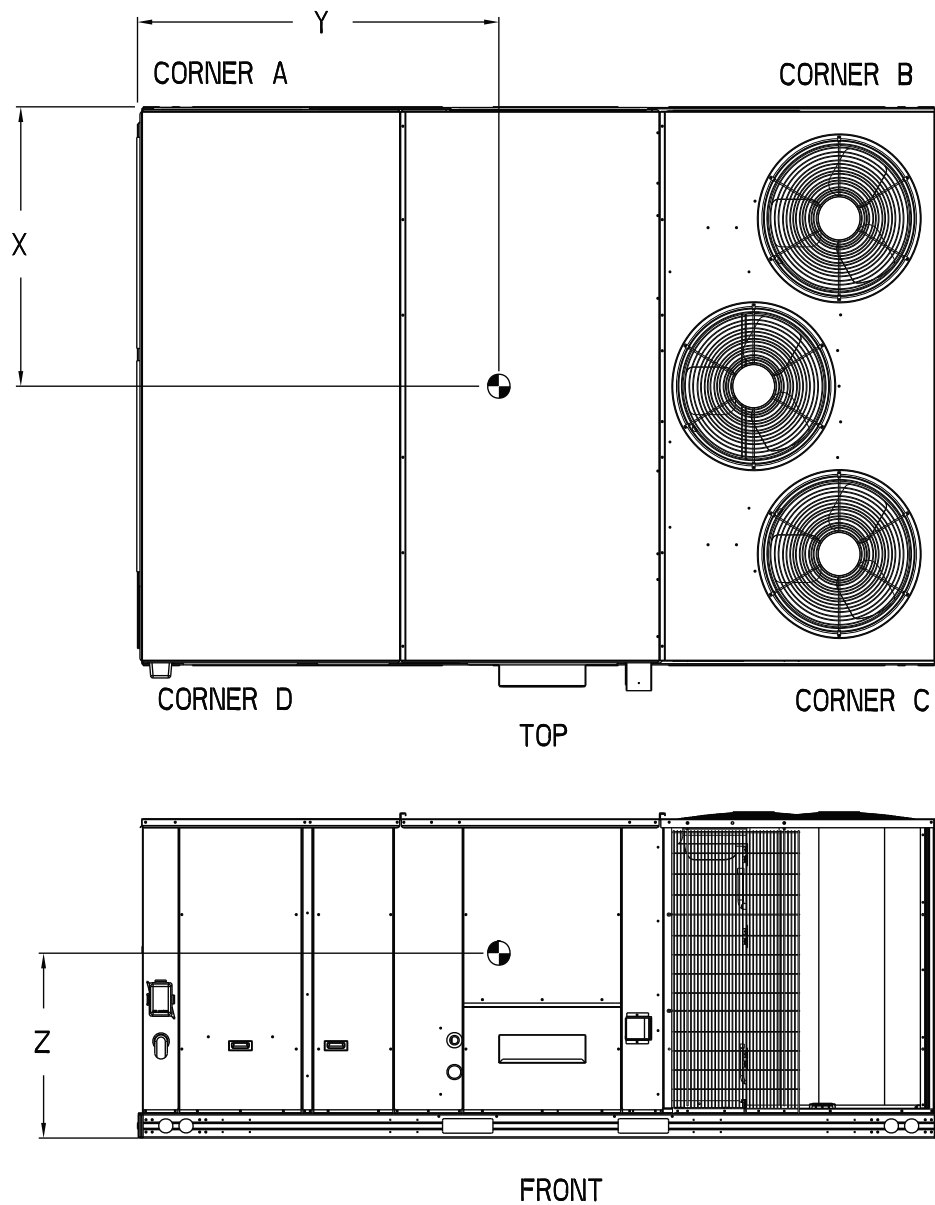


Fig. 2 — Unit Dimensional Drawing – 18 Size Unit (cont)

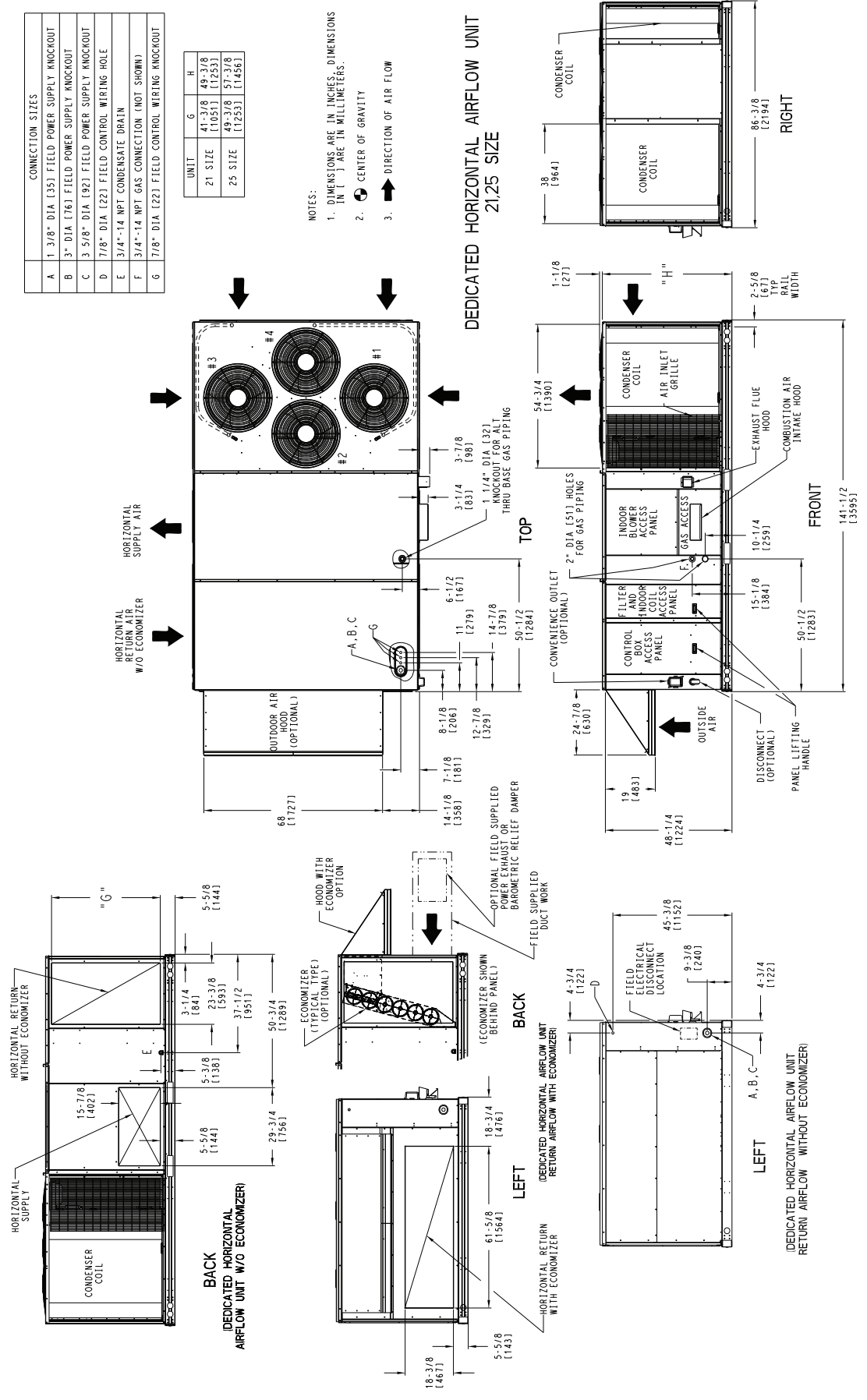


Fig. 3 — Unit Dimensional Drawing – 21 and 25 Size Unit

UNIT	OUTDOOR COIL TYPE	STD UNIT WEIGHT *		CORNER WEIGHT (A)		CORNER WEIGHT (B)		CORNER WEIGHT (C)		CORNER WEIGHT (D)		C.G.		
		LBS.	KG.	LBS.	KG.	LBS.	KG.	LBS.	KG.	LBS.	KG.	X	Y	Z
48TC21	RTPF	2102	956	474	215	390	177	593	269	582	265	47 1/2 [1207]	71 1/4 [1810]	16 1/2 [419]
48TC25	RTPF	2247	1021	540	246	556	253	598	272	581	264	44 5/8 [1133]	71 5/8 [1819]	19 [483]

RTPF - ROUND TUBE, PLATE FIN (COPPER/ALUM)  
MCHX - NOVATION (ALUM/ALUM)

\* STANDARD UNIT WEIGHT IS WITH LOW GAS HEAT AND WITHOUT PACKAGING.

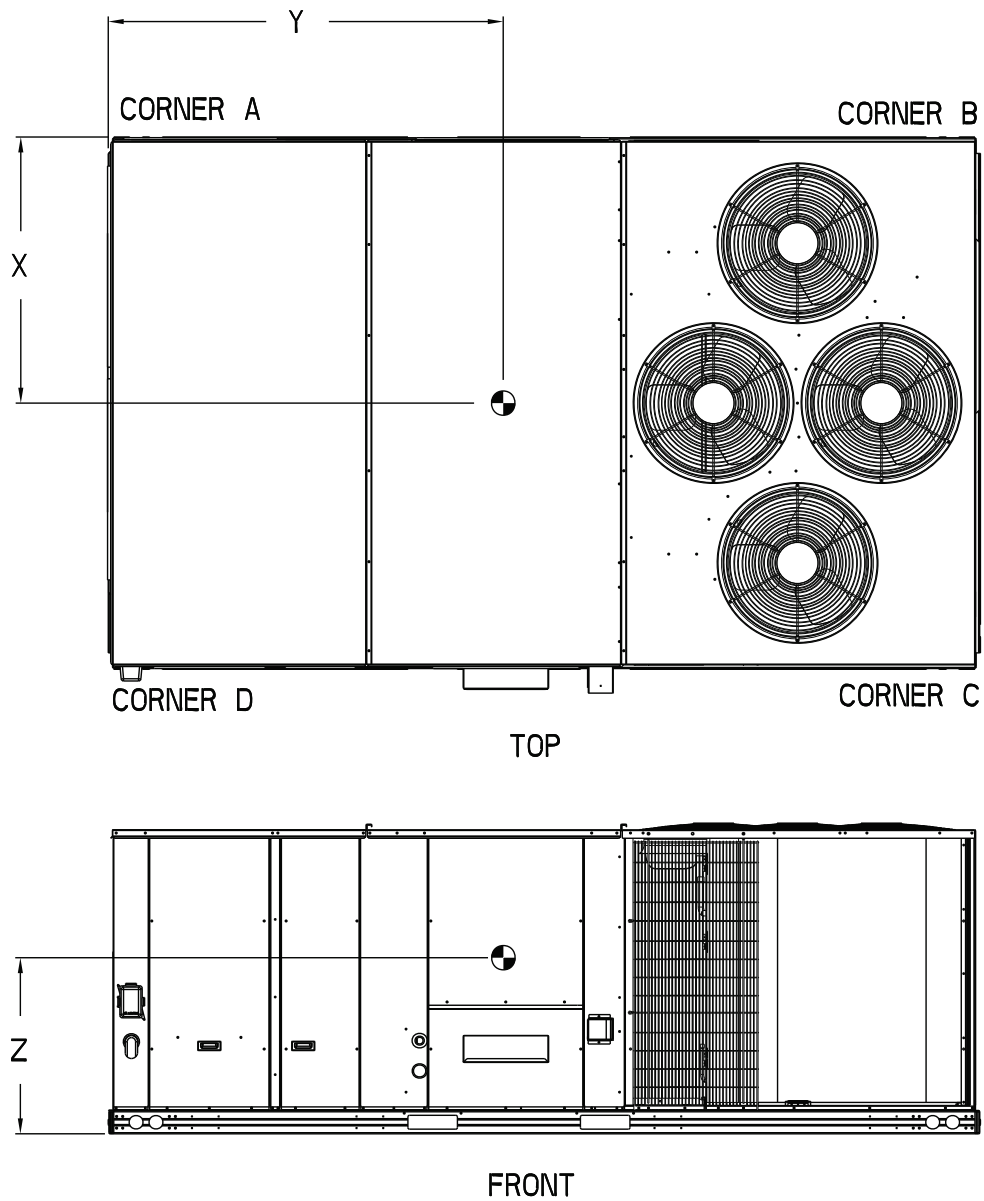


Fig. 3 — Unit Dimensional Drawing – 21 and 25 Size Unit (cont)

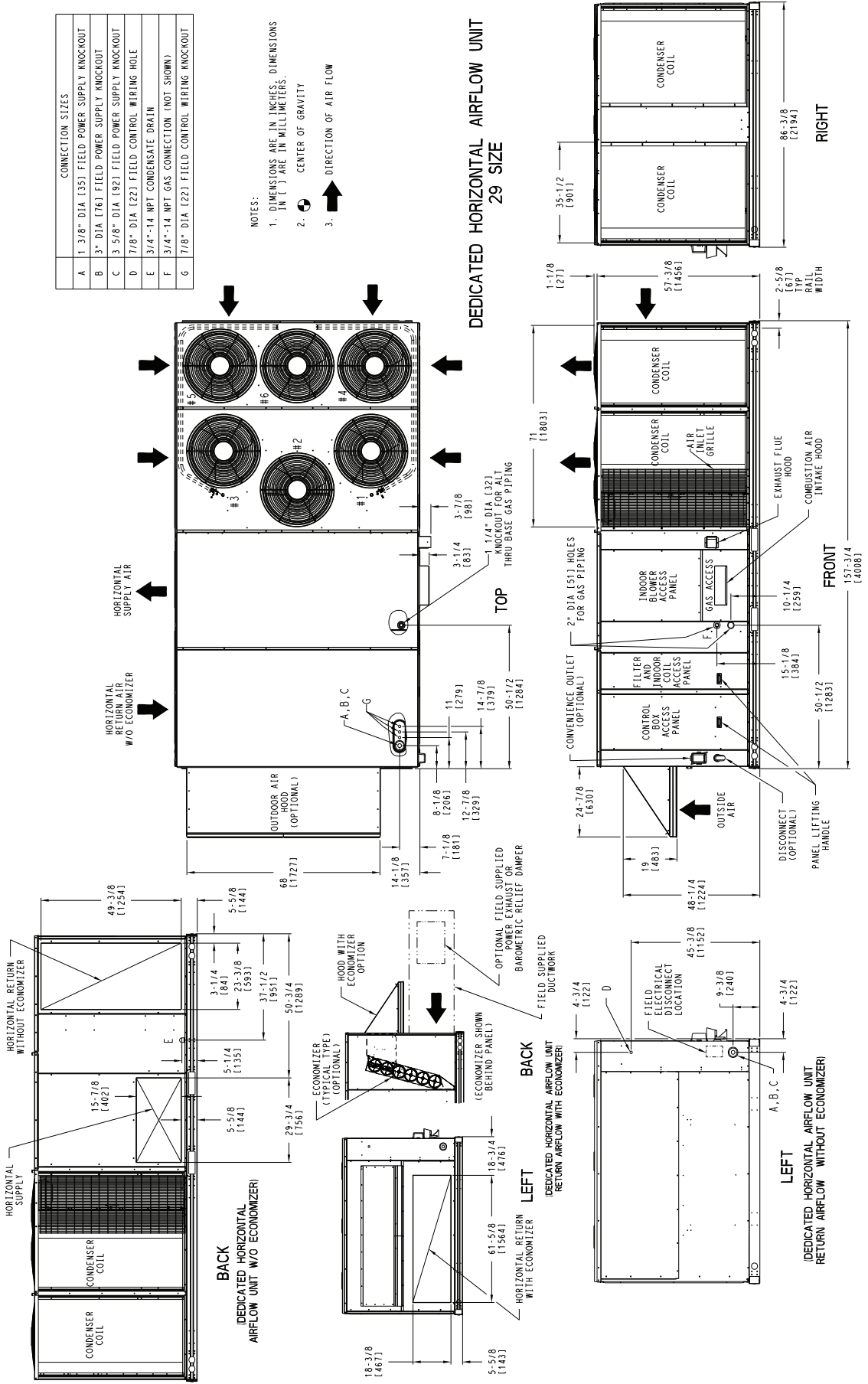


Fig. 4 — Unit Dimensional Drawing – 29 Size Unit

UNIT	STD UNIT WEIGHT *		CORNER WEIGHT (A)		CORNER WEIGHT (B)		CORNER WEIGHT (C)		CORNER WEIGHT (D)		C.G.		
	LBS.	KG.	LBS.	KG.	LBS.	KG.	LBS.	KG.	LBS.	KG.	X	Y	Z
48TC29	2292	1042	577	262	559	254	583	265	602	274	44 [1118]	77 1/2 [1969]	19 [483]

\* STANDARD UNIT WEIGHT IS WITH LOW GAS HEAT AND WITHOUT PACKAGING.

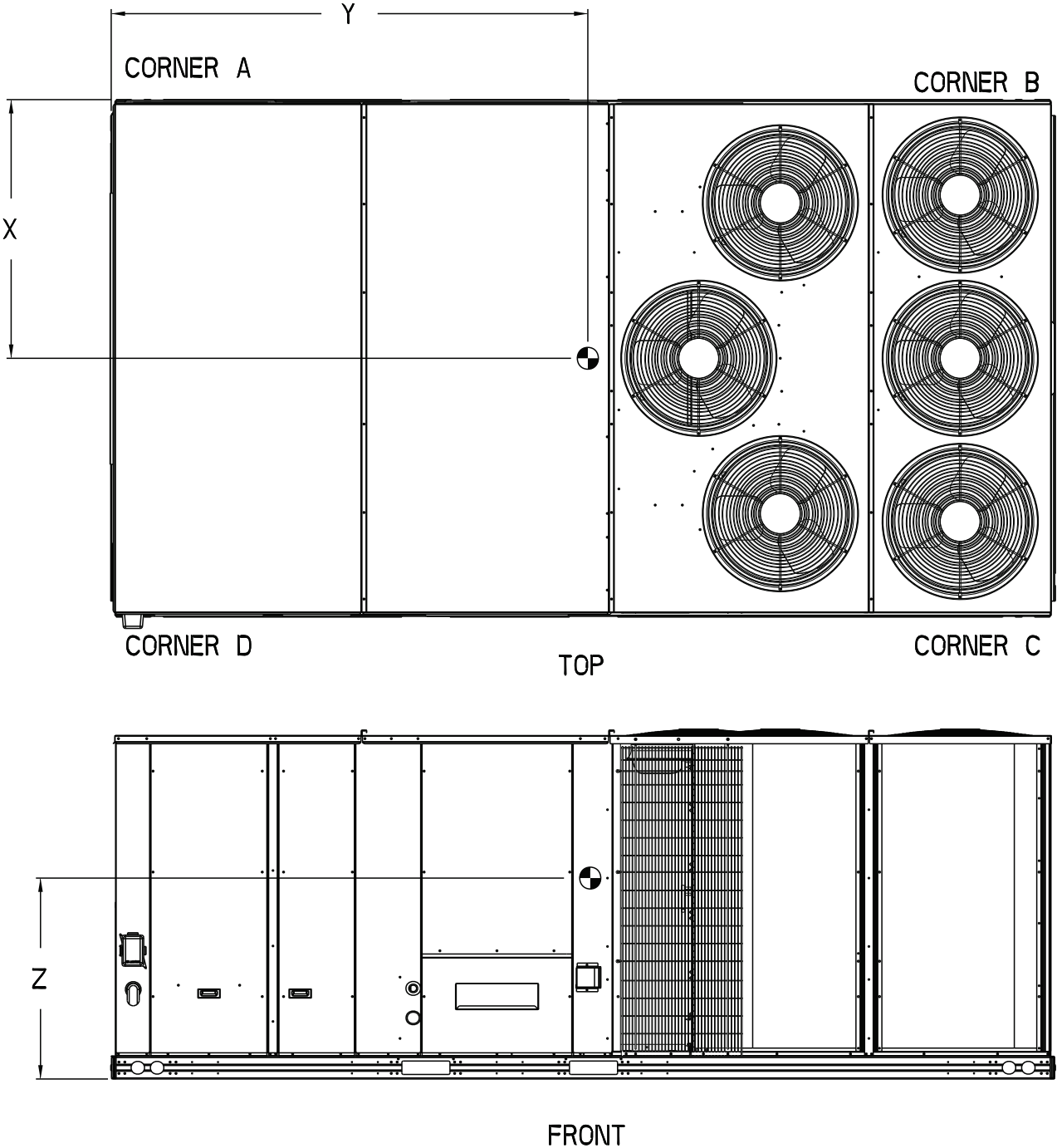
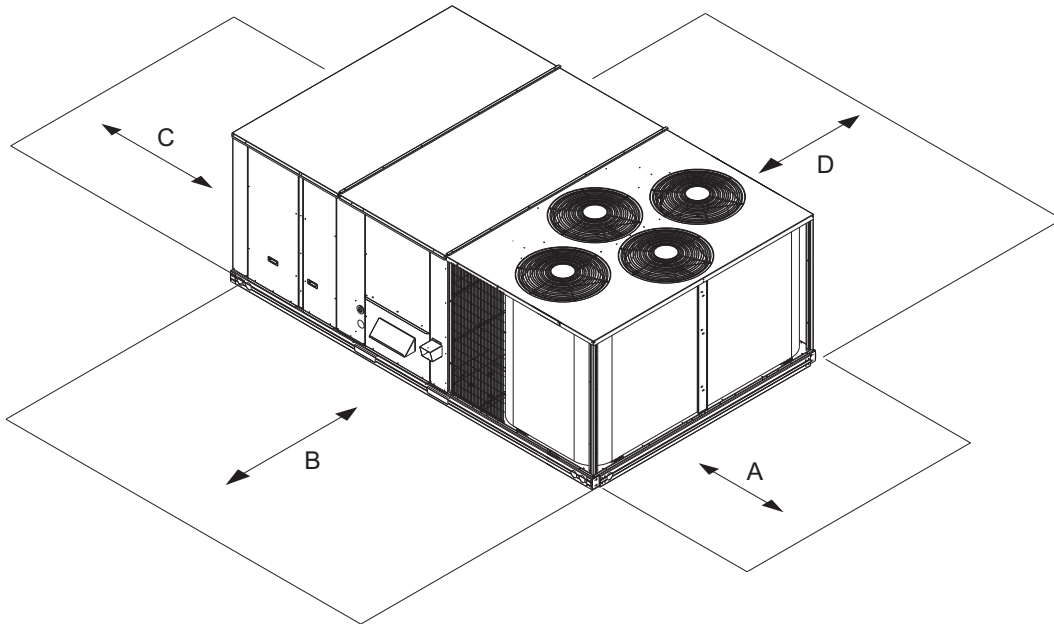


Fig. 4 — Unit Dimensional Drawing – 29 Size Unit (cont)



LOCATION	DIMENSION in. (mm)	CONDITION
A	36 (914)	Recommended clearance for air flow and service
B	42 (1067)	Recommended clearance for air flow and service
C	18 (457)	No convenience outlet No economizer No field-installed disconnect on the economizer hood side (factory-installed disconnect installed)
	36 (914)	Convenience outlet installed Vertical surface behind servicer is electrically non-conductive (e.g. wood, fiberglass).
	42 (1067)	Convenience outlet installed Vertical surface behind servicer is electrically conductive (e.g. metal, masonry)
	96 (2438)	Economizer and/or power exhaust installed Check for sources of flue products with 10 feet (3 meters) of economizer fresh air intake
D	42 (1067)	Recommended clearance for service

NOTE: Unit not designed to have overhead obstruction. Contact Application Engineering for guidance on any application planning overhead obstruction or for vertical clearances.

**Fig. 5 — Service Clearance Dimensional Drawing**

**Table 2 — Operating Weights**

48TC	UNITS — lb (kg)			
	18	21	25	29
<b>Base Unit</b>	1892 (860)	2102 (956)	2247 (1021)	2292 (1042)
<b>Economizer</b>	246 (112)	246 (112)	246 (112)	246 (112)
<b>Powered Outlet</b>	35 (16)	35 (16)	35 (16)	35 (16)
<b>Humidi-MiZer® System</b>	110 (50)	120 (54)	120 (54)	120 (54)
<b>Curb</b>				
<b>14-in. (356 mm)</b>	240 (109)	255 (116)	255 (116)	255 (116)
<b>24-in. (610 mm)</b>	340 (154)	355 (161)	355 (161)	355 (161)

NOTE: Unit is not designed to have overhead obstruction. Contact Application Engineering for guidance on any application planning overhead obstruction or for vertical clearances.

## INSTALLATION

**Job-Site Survey** — Complete the following checks before installation.

1. Consult local building codes and the NEC (National Electrical Code) ANSI/NFPA 70 for special installation requirements.
2. Determine unit location (from project plans) or select unit location.
3. Check for possible overhead obstructions which may interfere with unit lifting or rigging.



**Step 1 — Plan for Unit Location** — Select a location for the unit and its support system (curb or other) that provides for the minimum clearances required for safety. This includes the clearance to combustible surfaces, unit performance and service access below, around and above unit as specified in unit drawings. See Fig. 5.

NOTE: Consider also the effect of adjacent units.

Be sure that unit is installed such that snow will not block the combustion intake or flue outlet.

Unit may be installed directly on wood flooring or on class A, B, or C roof-covering material when roof curb is used.

Do not install unit in an indoor location. Do not locate air inlets near exhaust vents or other sources of contaminated air. For proper unit operation, adequate combustion and ventilation air must be provided in accordance with Section 5.3 (Air for Combustion and Ventilation) of the National Fuel Gas Code, ANSI Z223.1 (American National Standards Institute) and NFPA (National Fire Protection Association) 54 TIA-54-84-1. In Canada, installation must be in accordance with the CAN1-B149 installation codes for gas burning appliances.

Although unit is weatherproof, avoid locations that permit water from higher level runoff and overhangs to fall onto the unit.

Locate mechanical draft system flue assembly at least 4 ft (1.2 m) from any opening through which combustion products could enter the building, and at least 4 ft (1.2 m) from any adjacent building (or per local code). Locate the flue assembly at least 10 ft (3.05 m) from an adjacent unit's fresh air intake hood if within 3 ft (0.91 m) of same elevation (or per local code). When unit is located adjacent to public walkways, flue assembly must be at least 7 ft (2.1 m) above grade.

Select a unit mounting system that provides adequate height to allow installation of condensate trap per requirements. Refer to Step 11 — Install External Condensate Trap and Line — for required trap dimensions.

ROOF MOUNT — Check building codes for weight distribution requirements. Unit operating weight is shown in Table 2.

**Step 2 — Plan for Sequence of Unit Installation** — The support method used for this unit will dictate different sequences for the steps of unit installation. Review the following for recommended sequences for installation steps.

ROOF CURB MOUNT

- Install curb
- Install thru-base service connection fittings (affects curb and unit)
- Rig and place unit
- Remove duct covers and top skid
- Install smoke detector return air sensor tube
- Install field-fabricated ductwork at unit duct opening
- Install outside air hood
- Install combustion air hood
- Install flue hood
- Install gas piping
- Install condensate line trap and piping
- Make electrical connections
- Install other accessories

PAD-MOUNTED INSTALLATION

- Prepare pad and unit supports
- Rig and place unit
- Remove duct covers and top skid
- Install smoke detector return air sensor tube
- Install field-fabricated ductwork at unit duct openings
- Install outdoor air hood

- Install combustion air hood
- Install flue hood
- Install gas piping
- Install condensate line trap and piping
- Make electrical connections
- Install other accessories

FRAME-MOUNTED INSTALLATION — Frame-mounted applications generally follow the sequence for a curb installation. Adapt as required to suit specific installation plan.

**Step 3 — Inspect Unit** — Inspect unit for transportation damage. File any claim with transportation agency.

Confirm before installation of unit that voltage, amperage and circuit protection requirements listed on unit data plate agree with power supply provided.

On units with hinged panel option, check to be sure all latches are tight and in closed position.

Locate the carton containing the outside air hood parts in the rear blower assembly. Do not remove carton until unit has been rigged and located in final position.

**Step 4 — Provide Unit Support**

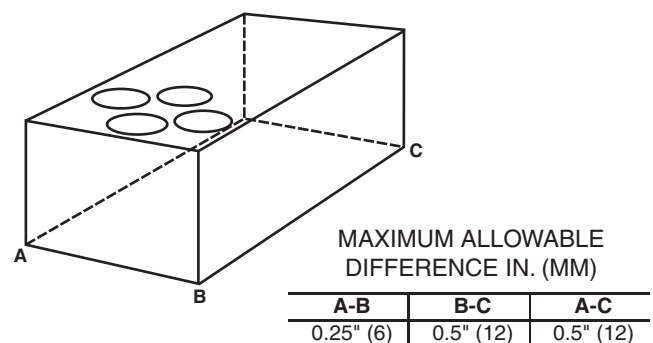
SLAB MOUNT — Provide a level concrete slab that extends a minimum of 6-in. (150 mm) beyond unit cabinet. Install a gravel apron in front of condenser coil air inlet to prevent grass and foliage from obstructing airflow.

NOTE: Horizontal units may be installed on a roof curb if required.

ROOF CURB MOUNT — Accessory roof curb details and dimensions are shown in Fig. 9-11. Assemble and install accessory roof curb in accordance with instructions shipped with the curb.

NOTE: Although gasketing is supplied with the roof curb it is not necessary for horizontal unit installations.

Curb should be level. This is necessary for unit drain to function properly. Unit leveling tolerances are shown in Fig. 6. Refer to Accessory Roof Curb Installation Instructions for additional information as required.

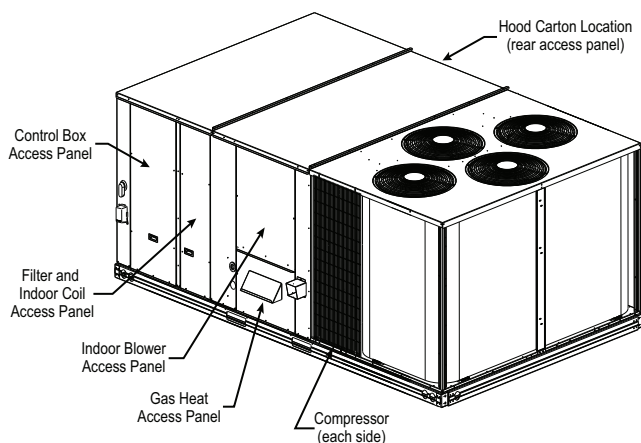


**Fig. 6 — Unit Leveling Tolerances**

Install insulation, cant strips, roofing felt, and counter flashing as shown. *Thru-the-base power connection must be installed before the unit is set on the roof curb.* If field-installed thru-the-roof curb gas connections are desired remove knockout in basepan located in the gas section, see Fig. 7 for gas section location and Fig. 2-4 for the knockout location. Gas connections and power connections to the unit must be field-installed after the unit is installed on the roof curb.

Level by using unit frame as a reference. See Table 1 (on page 2) and Fig. 8 for additional information.

Lifting holes are provided in base rails as shown in Fig. 8. Refer to rigging instructions on unit.



**Fig. 7 — Typical Access Panel and Compressor Locations**

If electric and control wiring is to be routed through the basepan, remove knockouts in basepan located in control box area of access panel. See Fig. 2-4 for basepan knockout locations for location. Attach the service connections to the basepan.

**ALTERNATE UNIT SUPPORT (IN LIEU OF SLAB OR CURB MOUNT)** — A non-combustible sleeper rail can be used in the unit curb support area. If sleeper rails cannot be used, support the long sides of the unit with a minimum of 4 equally spaced 4-in. x 4-in. (102 mm x 102 mm) pads on each side. Locate pads so that they support the rails. Make sure to avoid the fork openings.

**Step 5 — Rig and Place Unit** — Keep unit upright and do not drop. Spreader bars are not required if top crating is left on unit. Rollers may be used to move unit across a roof.

**⚠ CAUTION**

**UNIT DAMAGE HAZARD**

Failure to follow this caution may result in equipment damage.

All panels must be in place when rigging. Unit is not designed for handling by fork truck when packaging is removed.

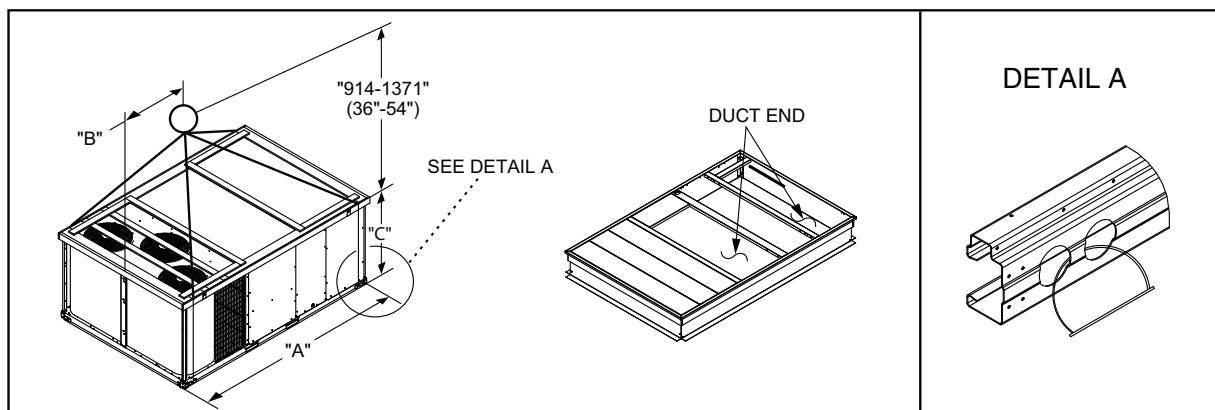
Although unit is weatherproof, guard against water from higher level runoff and overhangs.

*Flue vent discharge must have a minimum horizontal clearance of 48 in. (1220 mm) from electric and gas meters, gas regulators, and gas relief equipment. Minimum distance between unit and other electrically live parts is 48 inches (1220 mm).*

Flue gas can deteriorate building materials. Orient unit such that flue gas will not affect building materials. Locate mechanical draft system flue assembly at least 48 in. (1220 mm) from an adjacent building or combustible material.

After unit is in position, remove rigging skids and shipping materials.

**POSITIONING ON CURB** — Position unit on roof curb so that the following clearances are maintained: 1/4 in. (6 mm) clearance between the roof curb and the base rail inside the right and left, 1/2 in. (12 mm) clearance between the roof curb and the base rail inside the front and back. This will result in the distance between the roof curb and the base rail inside on the condenser end of the unit being approximately equal to Details A and B in Figs. 9-11.



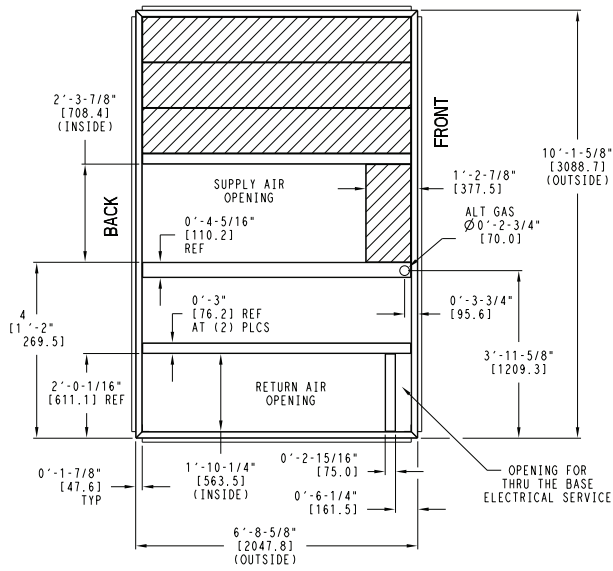
UNIT	MAX WEIGHT		DIMENSIONS					
			A		B		C	
	LB	KG	in.	mm	in.	mm	in.	mm
48TC**18	2339	1061	127.8	3249	58.7	1491	52.3	1328
48TC**21	2549	1156	141.5	3595	71.5	1816	52.3	1328
48TC**25	2699	1224	141.5	3595	71.5	1816	60.3	1532
48TC**29	2748	1246	157.8	4007	80.3	2040	60.3	1532

**NOTES:**

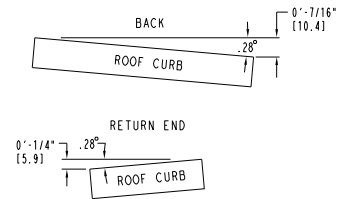
- Dimensions in ( ) are inches.
- Hook rigging shackles through holes in base rail, as shown in detail "A." Holes in base rails are centered around the unit center of gravity. Use wooden top to prevent rigging straps from damaging unit.

**Fig. 8 — Rigging Details**

UNIT SIZE	"A"	ROOF CURB ACCESSORY
18	1'-2" [356.0] 2'-0" [610.0]	CRRFCURB045A00 CRRFCURB046A00



- NOTES:
- 1 ROOF CURB ACCESSORY IS SHIPPED UNASSEMBLED.
  - 2 DIMENSIONS IN [ ] ARE IN MILLIMETERS.
  - 3 ROOF CURB GALVANIZED STEEL.
  - 4 ATTACH DUCTWORK TO CURB (FLANGES ON DUCT REST ON CURB)
  - 5 SERVICE CLEARANCE 4 FT ON EACH SIDE
- ➔ DIRECTION OF AIR FLOW



MAX CURB LEVELING TOLERANCES

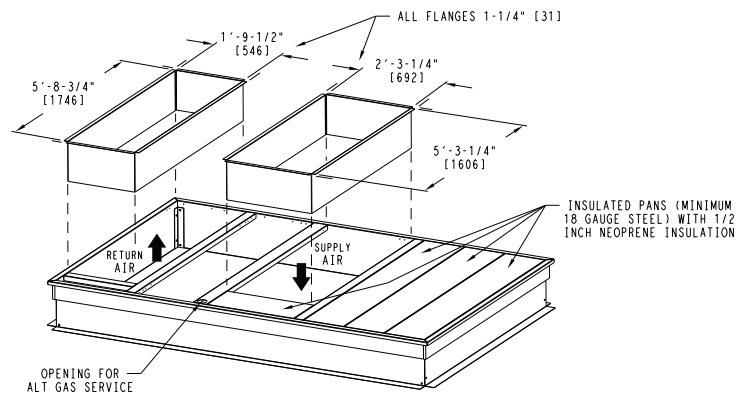
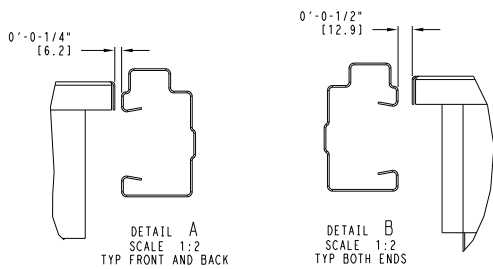
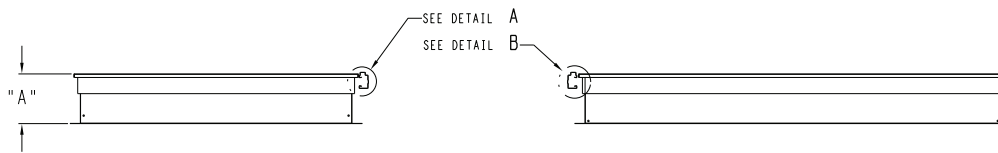
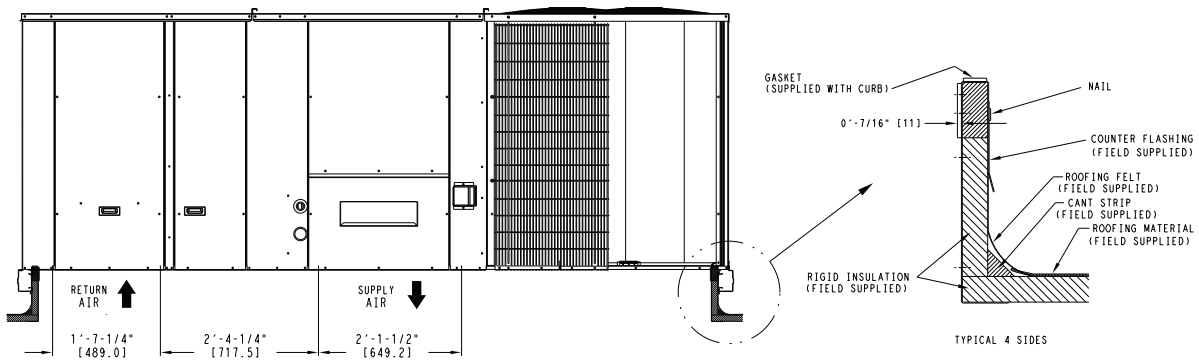
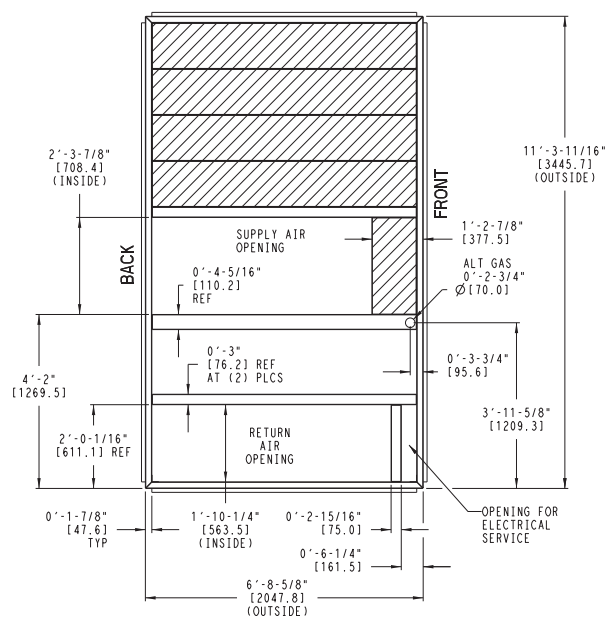


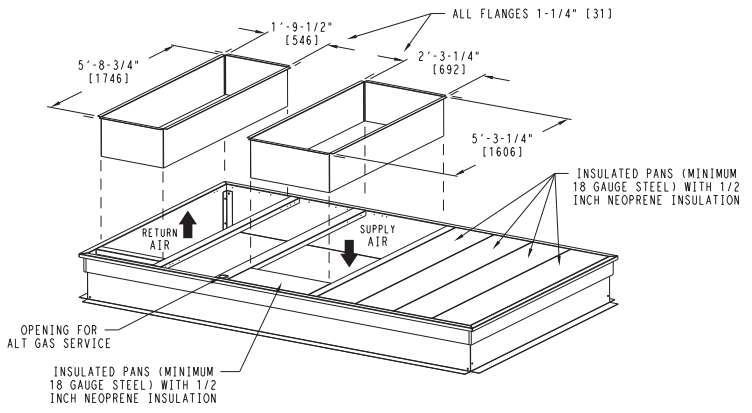
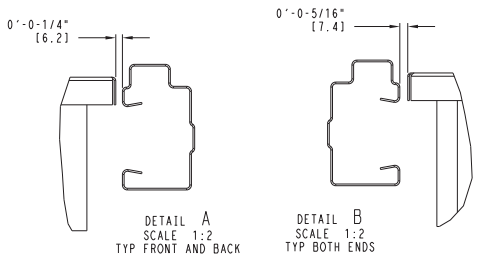
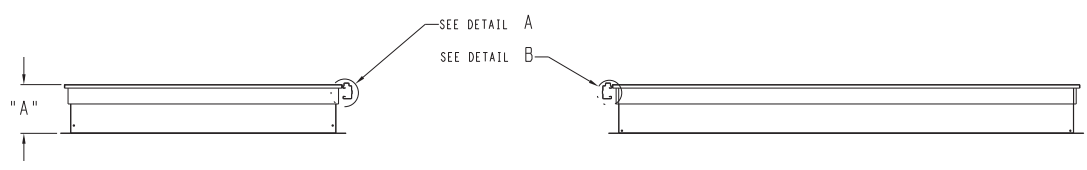
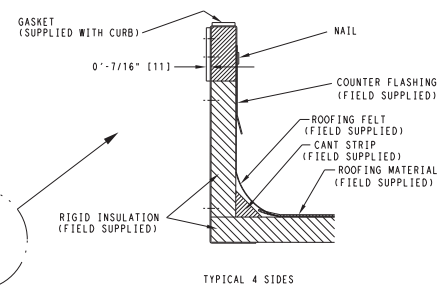
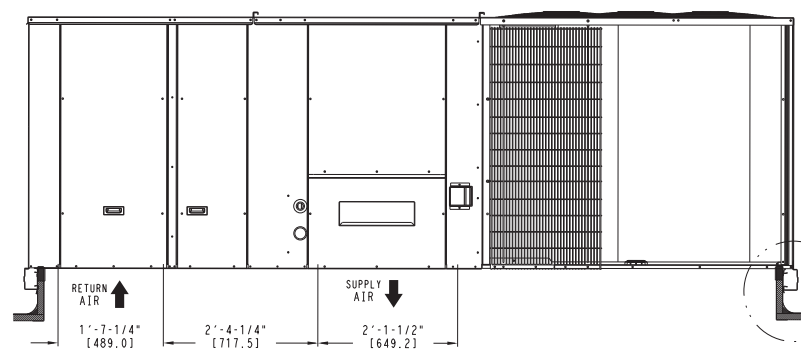
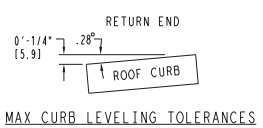
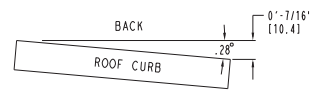
Fig. 9 — Roof Curb Details — 18 Size Unit

UNIT SIZE	"A"	ROOF CURB ACCESSORY
21, 25	1'-2" [356.0]	CRRFCURB047A00
	2'-0" [610.0]	CRRFCURB048A00



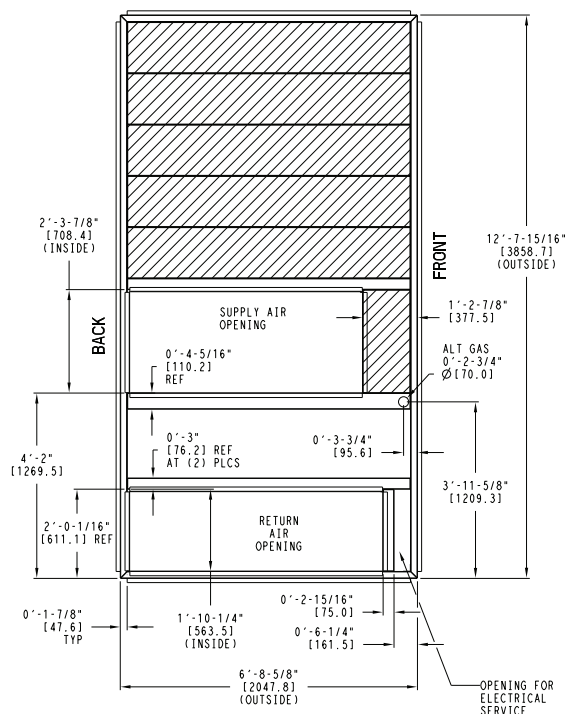
- NOTES:
- 1 ROOF CURB ACCESSORY IS SHIPPED UNASSEMBLED.
  - 2 DIMENSIONS IN ( ) ARE IN MILLIMETERS.
  - 3 ROOF CURB GALVANIZED STEEL.
  - 4 ATTACH DUCTWORK TO CURB (FLANGES ON DUCT REST ON CURB)
  - 5 SERVICE CLEARANCE 4 FT ON EACH SIDE

➔ DIRECTION OF AIR FLOW



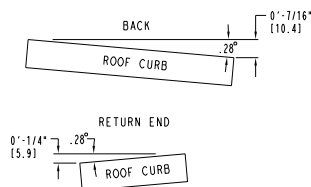
**Fig. 10 — Roof Curb Details — 21 and 25 Size Units**

UNIT SIZE	"A"	ROOF CURB ACCESSORY
29	1'-2" [356.0] 2'-0" [610.0]	CRRFCURB049A00 CRRFCURB050A00



- NOTES:
- 1 ROOF CURB ACCESSORY IS SHIPPED UNASSEMBLED.
  - 2 BOLT HEADS TO BE ON INSIDE OF FLANGE. CLEARANCE IS (11) 0-0-7/16" TYP ALL CORNERS.
  - 3 DIMENSIONS IN [ ] ARE IN MILLIMETERS.
  - 4 ROOF CURB GALVANIZED STEEL.
  - 5 ATTACH DUCTWORK TO CURB (FLANGES ON DUCT REST ON CURB)
  - 6 SERVICE CLEARANCE 4 FT ON EACH SIDE
  - 7 GAS SERVICE PLATE IS PART OF A SEPARATELY SHIPPED ACCESSORY PACKAGE.
  - 8 GAS SERVICE PLATE CAN BE USED WITH EITHER ACCESSORY ROOFCURB.

➔ DIRECTION OF AIR FLOW



MAX CURB LEVELING TOLERANCES

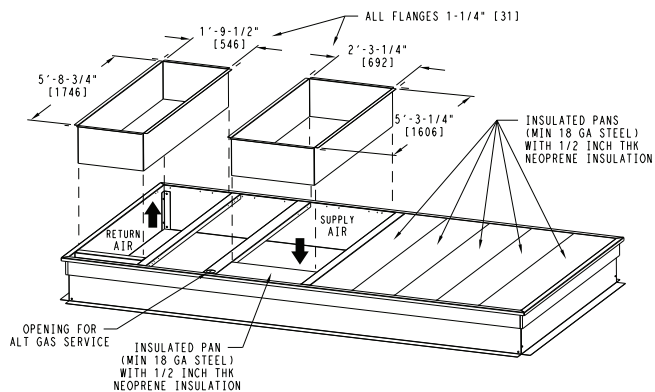
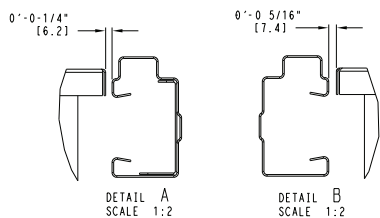
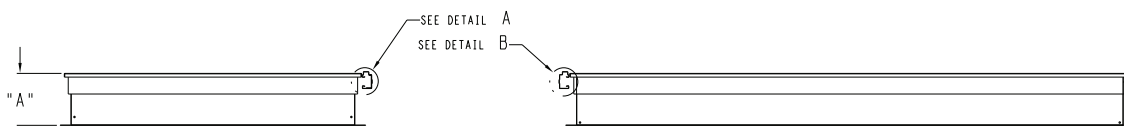
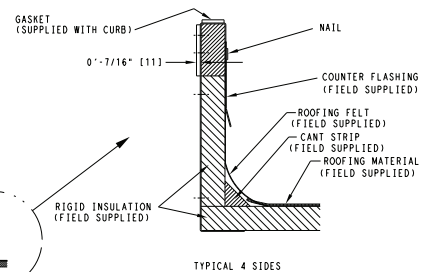
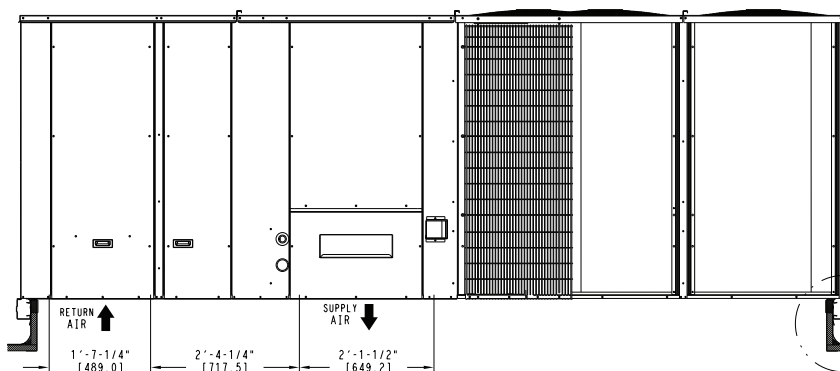


Fig. 11 — Roof Curb Details — 29 Size Units

**Step 6 — Field Fabricate Ductwork —** Cabinet return-air static pressure (a negative condition) shall not exceed 0.5 in. wg (87 Pa) with economizer or without economizer.

Fabricate supply ductwork so that the cross sectional dimensions are equal to or greater than the unit supply duct opening dimensions for the first 18 in. (458 mm) of duct length from the unit basepan.

Insulate and weatherproof all external ductwork, joints, and roof openings with counter flashing and mastic in accordance with applicable codes.

Ducts passing through unconditioned spaces must be insulated and covered with a vapor barrier.

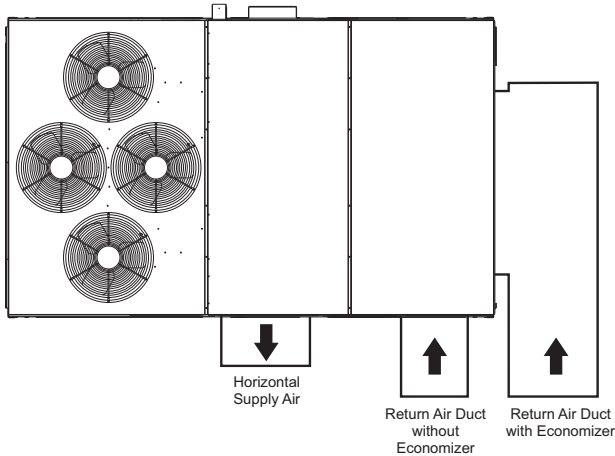
A minimum clearance is not required around ductwork.

**CAUTION**

Failure to follow this caution may result in damage to roofing materials.

Membrane roofs can be cut by sharp sheet metal edges. Be careful when placing any sheet metal parts on such roof.

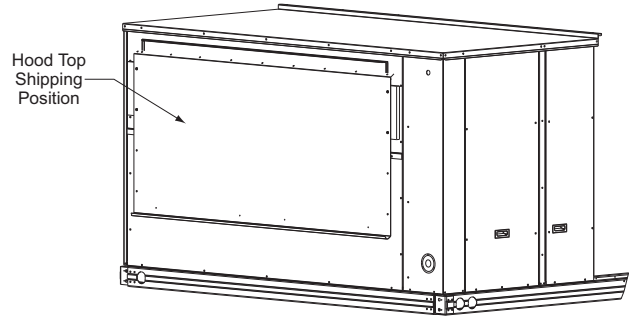
**Step 7 — Horizontal Duct Connection —** Refer to Figs. 2-4 for locations and sizes of the horizontal duct connections. Note that there are two different return air duct connection locations – one for unit without an economizer (on back side of unit) and a different one for unit equipped with an economizer (on left end, under the economizer hood). The supply air duct connection is on the back side. See Fig. 12 for top view depicting typical horizontal duct arrangements.



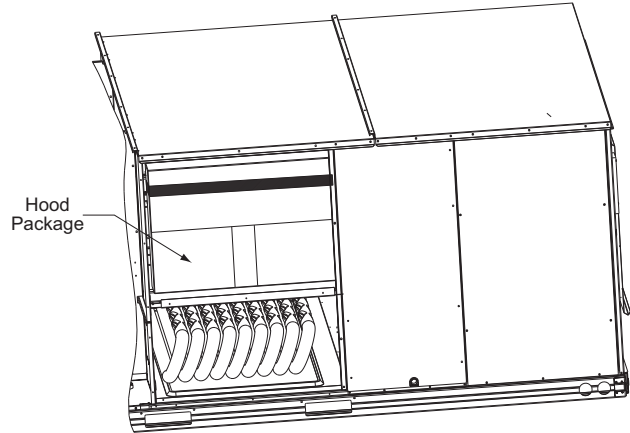
**Fig. 12 — Horizontal Duct Opening Dimensions**

Field-supplied (3/4-inch) flanges should be attached to horizontal duct openings (see Fig. 12) and all ductwork should be secured to the flanges. Insulate and weatherproof all external ductwork, joints, and roof or building openings with counter flashing and mastic in accordance with applicable codes.

**Step 8 — Install Outside Air Hood (Factory-Option) —** The outside air hood for factory-option economizer and two-position damper is shipped in knock-down form and requires field assembly. The panel for the hood top is shipped on the end of the unit (see Fig. 13). The remaining parts for the hood assembly (including side panels, filters and tracks) are shipped in a carton that is secured to the rear of the blower assembly. Access the carton location through rear panel (see Fig. 14).



**Fig. 13 — Hood Top — Shipping Position**



**Fig. 14 — Hood Package — Shipping Location**

To remove the hood parts package:

1. Remove the back blower access panel.
2. Locate and cut the strap, being careful not to damage any wiring.
3. Carefully lift the hood package carton through the back blower access opening.

See Fig. 15 for identification of the various parts of the hood assembly.

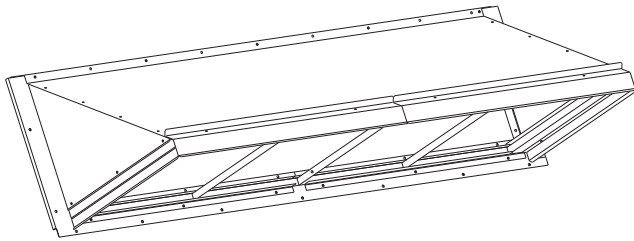
Item #	Description	Qty
1	Angles	4
2	Side Plates	2
3	Hood	1
4	Outdoor Air Screens	4
5	Side Filter Supports	2
6	Side Drip Angles	2
7	Top Diverters	2

**Fig. 15 — Hood Part Identification and Seal Strip Application Areas**



To assemble the outside air hood (see Fig. 16):

1. Remove hood top panel from shipping position on unit end.
2. Install four angles to the upper end panel using the screws provided.
3. Apply seal strip to mating flanges on the side plates of the hood (see Fig. 15).
4. Secure side plates to panel using the screws provided.
5. Apply seal strip to mating flange of the hood (see Fig. 15).
6. Secure top flange using screws provided in kit.
7. Install outdoor air screens by sliding them into the channel formed by the four angles installed in Step 2. Make sure that the screens extend across the entire length of the hood.
8. Install side filter supports using the screws provided.
9. Install side drip angles using the screws provided.
10. Run a continuous length of seal strip across the hood covering the engagement holes in the lower hood.
11. Install top diverter using the screws provided.
12. On units with barometric relief, remove screws at bottom of relief damper. **Do not discard damper door.**

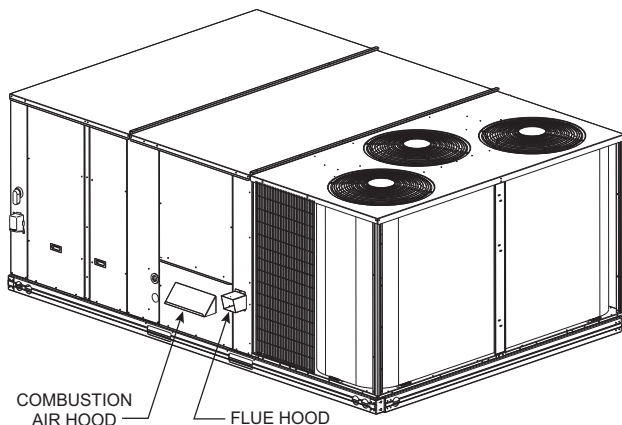


**Fig. 16 — Hood Assembly — Completed**

**Step 9 — Install Flue Hood and Combustion Air Hood**

— The flue hood is shipped screwed to the fan deck inside the burner compartment. Remove the burner access panel and then remove the flue hood from its shipping location. Using the screws provided, install flue hood in the location shown in Fig. 17.

The combustion air hood is attached to the back of the burner access panel. Remove the two screws securing the hood to the back of the burner access panel. Using the two screws, re-attach the hood to the front of the burner access panel as shown in Fig. 17.



**Fig. 17 — Flue Hood and Combustion Air Hood Details**

**Step 10 — Install Gas Piping** — Installation of the gas piping must be in accordance with local building codes and with applicable national codes. In U.S.A., refer to NFPA 54/ANSI Z223.1 National Fuel Gas Code (NFGC). In Canada, installation must be in accordance with the CAN/CSA B149.1 and CAN/CSA B149.2 installation codes for gas burning appliances.

This unit is factory equipped for use with Natural Gas fuel at elevations up to 2000 ft (610 m) above sea level. Unit may be field converted for operation at elevations above 2000 ft (610 m) and/or for use with liquefied petroleum fuel. See accessory kit installation instructions regarding these accessories.

NOTE: Furnace gas input rate on rating plate is for installation up to 2000 ft (610 m) above sea level. In U.S.A. the input rating for altitudes above 2000 ft (610 m) must be derated by 4% for each 1000 ft (305 m) above sea level. In Canada the input rating must be derated by 10% for altitudes of 2000 ft (610 m) to 4500 ft (1372 m) above sea level.

For natural gas applications, gas pressure at unit gas connection must not be less than 5 in. wg (1246 Pa) or greater than 13 in. wg (3240 Pa) while the unit is operating. For liquefied petroleum applications, the gas pressure must not be less than 11 in. wg (2740 Pa) or greater than 13 in. wg (3240 Pa) at the unit connection.

**GAS SUPPLY LINE** — The gas supply pipe enters the unit adjacent to the burner access panel on the front side of the unit, through the grommeted hole. The gas connection to the unit is made to the 3/4 in. FPT gas inlet port on the unit gas valve.

Table 3 lists typical 3/4 inch NPT (National Pipe Thread) field-supplied pipe fittings required for Thru-Base gas supply, starting from the unit gas valve (see Fig. 18).

**Table 3 — Typical 3/4 in. NPT Field Supplied Piping Parts**

ITEM	QTY	DESCRIPTION
1	1	90° Street Elbow
2	1	5 in. Long Nipple
3	1	Ground - Joint Union
4	1	3 in. Long Nipple
5	1	90° Elbow
6	1	12 in. Long Nipple
7	1	90° Elbow
8	1	3 in. Long Nipple
9	1	Tee
10	1	4 in. Long Nipple (Sediment Trap)
11	1	Cap
12	1	3 1/2 in. Long Nipple
13	1	NIBCO* Ball Valve (PN: GB30)
14	1	8 in. Long Nipple
15	1	90° Elbow

Pipe gas supply into 90 degree elbow item 15 (see Table 2) through the hole in the unit basepan.

For typical 3/4 inch NPT field supplied fittings required for NON Thru-Base gas supply starting from the unit gas valve, omit items 14 and 15 from Table 2 and pipe gas supply into TEE. See Fig. 19.

**Table 4 — Natural Gas Supply Line Pressure**

UNIT MODEL	UNIT SIZE	MIN.	MAX.
48TC**	18, 21, 25, 29	5.0 in.wg (1246 Pa)	13.0 in.wg (3240 Pa)

Manifold pressure is factory-adjusted for NG fuel use. Adjust as required to obtain best flame characteristics. See Table 5 for ranges.

\* NIBCO is a registered trademark of NIBCO Inc.

**Table 5 — Natural Gas Manifold Pressure Ranges**

UNIT MODEL	UNIT SIZE	HIGH FIRE	LOW FIRE
48TC**	18, 21, 25, 29	3.0 in.wg (747 Pa)	2.0 in.wg (498 Pa)

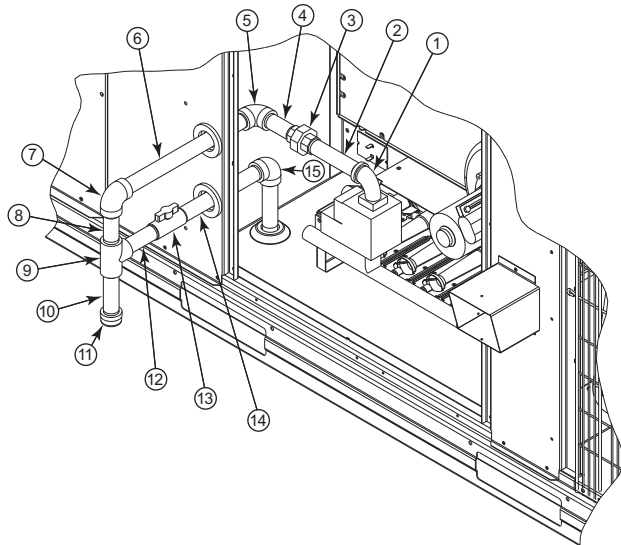
**CAUTION**

Failure to follow this caution may result in damage to equipment.

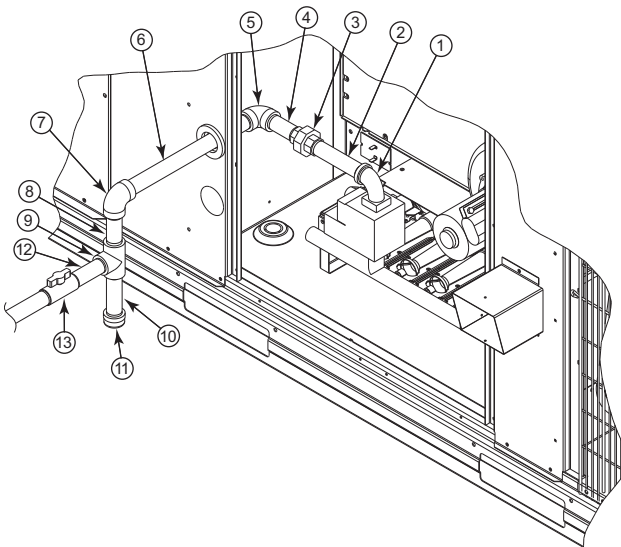
When connecting the gas line to the unit gas valve, the installer **MUST** use a backup wrench to prevent damage to the valve.

Install a gas supply line that runs to the unit heating section. Refer to the NFPA 54/NFPA or equivalent code for gas pipe sizing data. Do not use a pipe smaller than the size specified. Size the gas supply line to allow for a maximum pressure drop of 0.5-in. wg (124 Pa) between gas regulator source and unit gas valve connection when unit is operating at high-fire flow rate.

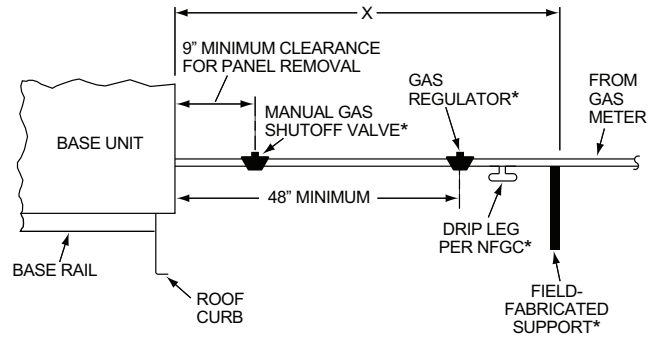
The gas supply line can approach the unit in two ways: horizontally from outside the unit (across the roof), or through unit basepan. Observe clearance to gas line components per Fig. 20.



**Fig. 18 — Gas Supply Line Piping with Thru-Base**



**Fig. 19 — Gas Supply Line Piping**



**LEGEND**

**NFGC** — National Fuel Gas Code

\* Field supplied.

NOTE: Follow all local codes.

STEEL PIPE NOMINAL DIAMETER (in.)	SPACING OF SUPPORTS X DIMENSION (ft)
1/2	6
3/4 or 1	8
1 1/4 or larger	10

**Fig. 20 — Gas Piping Guide**

**FACTORY-OPTION THRU-BASE CONNECTIONS**

**Electrical Connections** — Knockouts are located in the control box area. Remove the appropriate size knockout for high voltage connection. Use the field supplied connector depending on wiring or conduit being utilized. Remove the 7/8-in. (22 mm) knockout and appropriate connector for low voltage wiring. If non-unit powered convenience outlet is being utilized, remove the 7/8-in. (22 mm) knockout and utilize appropriate connector for 115 volt line. See “Step 12 — Make Electrical Connections” on page 20 for details.

**Gas Connections** — Remove the knockout in the base pan and route 3/4 in. gas line up through the opening. Install an elbow and route gas line through opening in panel after first removing plastic bushing. Install a gas shut off followed by a drip leg and ground-joint union. Route gas line into gas section through the grommet (Part #: KA56SL112) at the gas inlet and into the gas valve. See Fig. 17 and Table 3. If a regulator is installed, it must be located 4 feet (1.22 meters) from the flue outlet.

Some municipal codes require that the manual shutoff valve be located upstream of the sediment trap. See Fig. 18 for typical piping arrangements for gas piping that has been routed through the sidewall of the base pan.

When installing the gas supply line, observe local codes pertaining to gas pipe installations. Refer to the NFPA 54/ANSI Z223.1 NFGC latest edition (in Canada, CAN/CSA B149.1). In the absence of local building codes, adhere to the following pertinent recommendations:

1. Avoid low spots in long runs of pipe. Grade all pipe 1/4 in. in every 15 ft (7 mm in every 5 m) to prevent traps. Grade all horizontal runs downward to risers. Use risers to connect to heating section and to meter.
2. Protect all segments of piping system against physical and thermal damage. Support all piping with appropriate straps, hangers, etc. Use a minimum of one hanger every 6 ft (1.8 m). For pipe sizes larger than 1/2-in., follow recommendations of national codes.
3. Apply joint compound (pipe dope) sparingly and only to male threads of joint when making pipe connections. Use only pipe dope that is resistant to action of liquefied petroleum gases as specified by local and/or national codes. If using PTFE (Teflon\*) tape, ensure the material is

\* Teflon is a registered trademark of DuPont.

Double Density type and is labeled for use on gas lines. Apply tape per manufacturer's instructions.

4. Pressure-test all gas piping in accordance with local and national plumbing and gas codes before connecting piping to unit.

NOTE: Pressure test the gas supply system after the gas supply piping is connected to the gas valve. The supply piping must be disconnected from the gas valve during the testing of the piping systems when test pressure is in excess of 0.5 psig (3450 Pa). Pressure test the gas supply piping system at pressures equal to or less than 0.5 psig (3450 Pa). The unit heating section must be isolated from the gas piping system by closing the external main manual shutoff valve and slightly opening the ground-joint union.

Check for gas leaks at the field-installed and factory-installed gas lines after all piping connections have been completed. Use soap-and-water solution (or method specified by local codes and/or regulations).

### ⚠ WARNING

Failure to follow this warning could result in personal injury, death and/or property damage.

- Connect gas pipe to unit using a backup wrench to avoid damaging gas controls.
- Never purge a gas line into a combustion chamber.
- Never test for gas leaks with an open flame. Use a commercially available soap solution made specifically for the detection of leaks to check all connections.
- Use proper length of pipe to avoid stress on gas control manifold.

NOTE: If orifice hole appears damaged or it is suspected to have been redrilled, check orifice hole with a numbered drill bit of correct size. Never redrill an orifice. A burr-free and squarely aligned orifice hole is essential for proper flame characteristics.

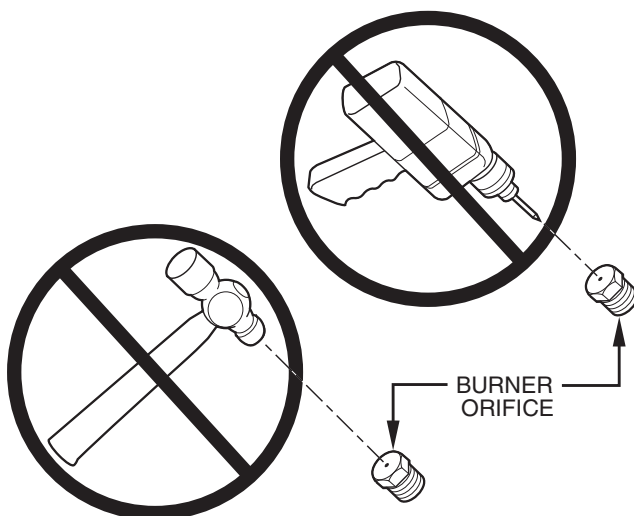


Fig. 21 — Orifice Hole

### Step 11 — Install External Condensate Trap and Line

The unit has one  $\frac{3}{4}$ -in. condensate drain connection on the end of the condensate pan (see Fig. 22). See Fig. 2-4, item "E", in the view labeled "BACK" for the location of the condensate drain connection.

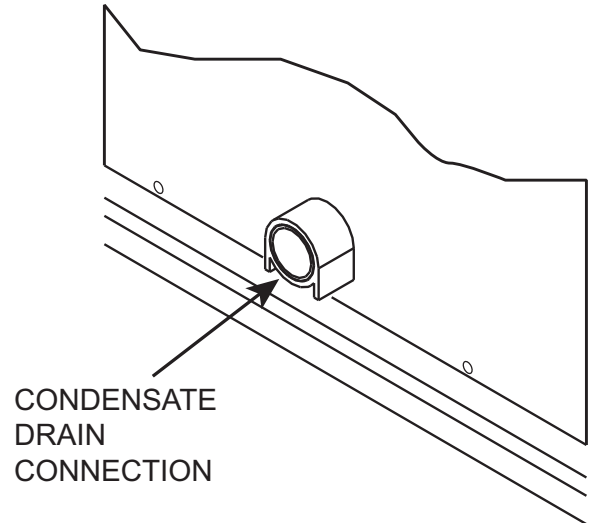
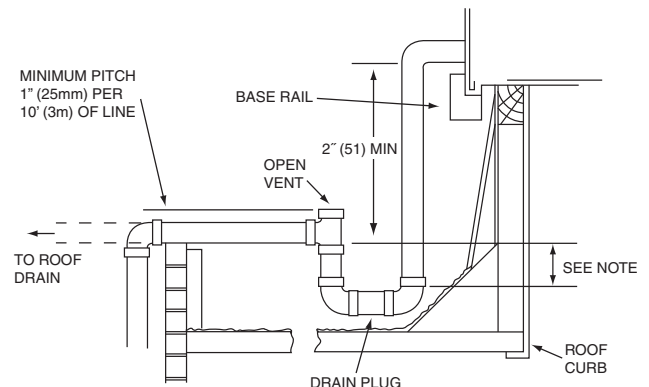


Fig. 22 — Condensate Drain Pan Connection

The piping for the condensate drain and external trap can be completed after the unit is in place. Hand tighten fittings to the drain pan fitting. Provide adequate support for the drain line. Failure to do so can result in damage to the drain pan. See Fig. 23.



NOTE: Trap should be deep enough to offset maximum unit static difference. A 4" (102 mm) trap is recommended.

Fig. 23 — Condensate Drain Piping Details

All units must have an external trap for condensate drainage. Install a trap at least 4-in. (102 mm) deep and protect against freeze-up. If drain line is installed downstream from the external trap, pitch the line away from the unit at 1-in. per 10 ft (25 mm in 3 m) of run. Do not use a pipe size smaller than the unit connection ( $\frac{3}{4}$ -in.).

## Step 12 — Make Electrical Connections

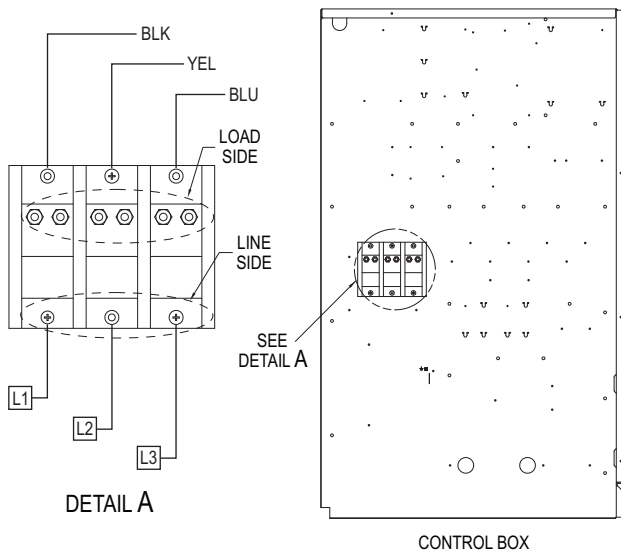
### ⚠ WARNING

Failure to follow this warning could result in personal injury or death.

Do not use gas piping as an electrical ground. Unit cabinet must have an uninterrupted, unbroken electrical ground to minimize the possibility of personal injury if an electrical fault should occur. This ground may consist of electrical wire connected to unit ground lug in control compartment, or conduit approved for electrical ground when installed in accordance with NEC (National Electrical Code); ANSI/NFPA 70, latest edition (in Canada, Canadian Electrical Code CSA [Canadian Standards Association] C22.1), and local electrical codes.

NOTE: Field-supplied wiring shall conform with the limitations of minimum 63°F (33°C) rise.

**FIELD POWER SUPPLY** — If equipped with optional Powered Convenience Outlet: The power source leads to the convenience outlet's transformer primary are not factory connected. Installer must connect these leads according to required operation of the convenience outlet. If an always-energized convenience outlet operation is desired, connect the source leads to the line side of the unit-mounted disconnect. (Check with local codes to ensure this method is acceptable in your area.) If a de-energize via unit disconnect switch operation of the convenience outlet is desired, connect the source leads to the load side of the unit disconnect. On a unit without a unit-mounted disconnect, connect the source leads to the line side with unit field power leads. See Fig. 24.



**Fig. 24 — Location of TB1**

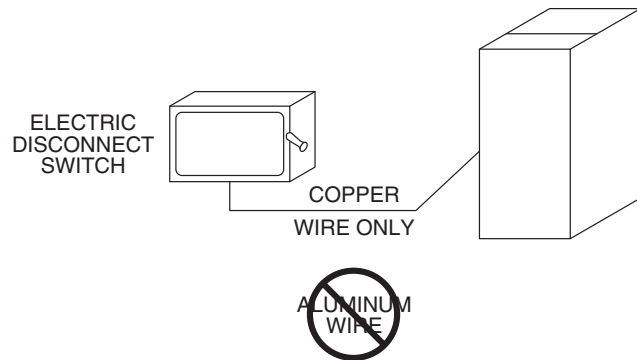
Field power wires are connected to the unit at line-side pressure lugs on the terminal block (see wiring diagram label for control box component arrangement) or at factory-installed option non-fused disconnect switch. Use copper conductors only.

NOTE: Make field power connections directly to line connection pressure lugs only.

### ⚠ WARNING

Failure to follow this warning could result in intermittent operation or unsatisfactory performance.

Do not connect aluminum wire between disconnect switch and air conditioning unit. Use only copper wire. (See Fig. 25.)



**Fig. 25 — Disconnect Switch and Unit**

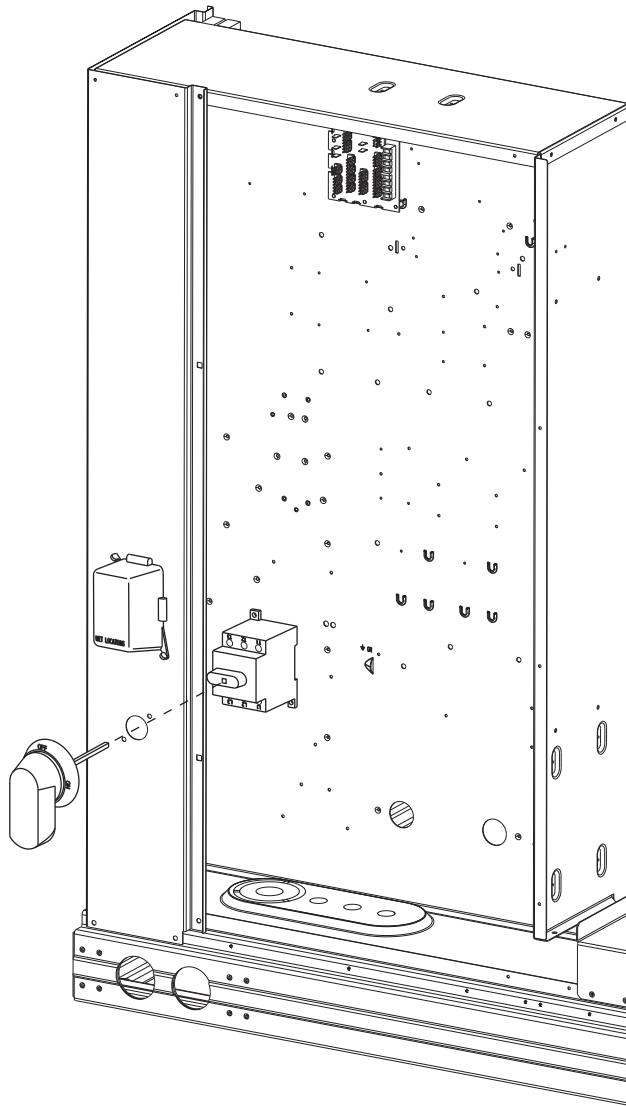
**UNITS WITHOUT FACTORY-INSTALLED NON-FUSED DISCONNECT** — When installing units, provide a disconnect switch per NEC (National Electrical Code) of adequate size. Disconnect sizing data is provided on the unit informative plate. Locate on unit cabinet or within sight of the unit per national or local codes. Do not cover unit informative plate if mounting the disconnect on the unit cabinet.

**UNITS WITH FACTORY-INSTALLED NON-FUSED DISCONNECT** — The factory-installed option non-fused disconnect switch (NFD) is located in the main control box. The manual switch handle and shaft are shipped in the control box and must be mounted on the corner post adjacent to the control box (see Fig. 26). Note that the tape covering the hole for the shaft in the corner post must be removed prior to handle and shaft installation.

**TO FIELD INSTALL THE NFD SHAFT AND HANDLE:**

1. Open the control box panel.
2. Make sure the NFD shipped from the factory is at OFF position (the arrow on the black handle knob or on the silver metal collar is at OFF).
3. Insert the shaft with the cross pin on the top of the shaft in the horizontal position.
4. Measure the tip of the shaft to the outside surface of the corner post to be 0.88 in.
5. Tighten the locking screw to secure the shaft to the NFD.
6. Turn the handle to OFF position with red arrow pointing at OFF.
7. Install the handle on to the corner post vertically with the red arrow pointing up.
8. Secure the handle to the corner post with (2) screws and lock washers supplied.





**Fig. 26 — Handle and Shaft Assembly for NFD**

**ALL UNITS** — All field wiring must comply with NEC and all local code requirements.

Size wire based on MCA (Minimum Circuit Amps) on the unit informative plate. See Fig. 27 for power wiring connections to the unit power terminal block and equipment ground. Maximum wire size is 2/0 AWG per pole.

Provide a ground-fault and short-circuit over-current protection device (fuse or breaker) per NEC Article 440 (or local codes). Refer to unit informative data plate for MOCP (Maximum Over-current Protection) device size.

Voltage to compressor terminals during operation must be within voltage range indicated on unit nameplate. On 3-phase units, voltages between phases must be balanced within 2% and the current within 10%. Use the formula below to determine the percent of voltage imbalance.

**CAUTION**

Failure to follow this caution may result in equipment damage.

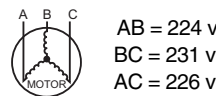
Operation on improper line voltage or excessive phase imbalance constitutes abuse and may cause damage to electrical components. Such operation would invalidate any applicable Carrier warranty.

**IMPORTANT:** Never operate a motor where a phase imbalance in supply voltage is greater than 2%. Use the following formula to determine the percentage of voltage imbalance.

Unbalanced 3-Phase Supply Voltage:

$$\text{Average Imbalance} = 100 \times \frac{\text{max voltage deviation from average voltage}}{\text{average voltage}}$$

Example: Supply voltage is 230-3-60



$$\% \text{ Voltage Imbalance} = 100 \times \frac{(224 + 231 + 226)}{3} = \frac{681}{3} = 227$$

Determine maximum deviation from average voltage.

$$(AB) 227 - 224 = 3 \text{ v}$$

$$(BC) 231 - 227 = 4 \text{ v}$$

$$(AC) 227 - 226 = 1 \text{ v}$$

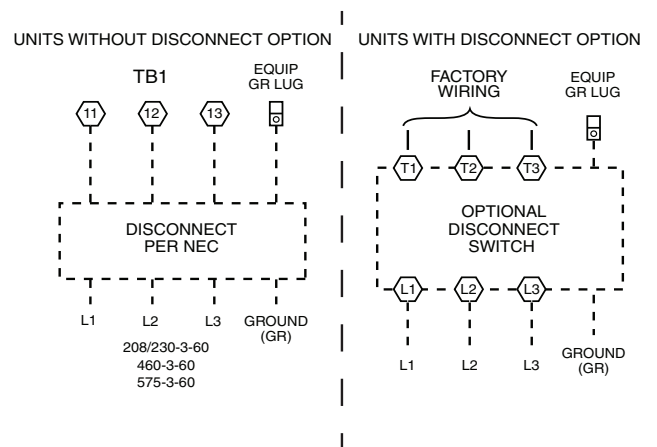
Maximum deviation is 4 v.

Determine percent of voltage imbalance.

$$\% \text{ Voltage Imbalance} = 100 \times \frac{4}{227} = 1.76\%$$

This amount of phase imbalance is satisfactory as it is below the maximum allowable 2%.

**IMPORTANT:** If the supply voltage phase imbalance is more than 2%, contact your local electric utility company immediately.



**Fig. 27 — Power Wiring Connections**

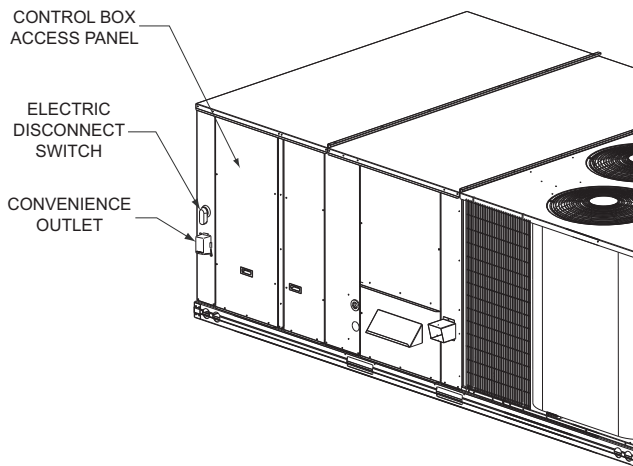
## CONVENIENCE OUTLETS

### **WARNING**

Failure to follow this warning could result in personal injury or death.

Units with convenience outlet circuits may use multiple disconnects. Check convenience outlet for power status before opening unit for service. Locate its disconnect switch, if appropriate, and open it. Lock-out and tag-out this switch, if necessary.

Two types of convenience outlets are offered on 48TC models: Non-unit powered and unit-powered. Both types provide a 125-volt GFCI (ground-fault circuit-interrupter) duplex receptacle rated at 15-A behind a hinged access cover, located on the corner panel of the unit. See Fig. 28.



**Fig. 28 — Convenience Outlet Location**

**Installing Weatherproof Cover** — A weatherproof while-in-use cover for the factory-installed convenience outlets is now required by UL standards. This cover cannot be factory-mounted due to its depth; it must be installed at unit installation. For shipment, the convenience outlet is covered with a blank cover plate.

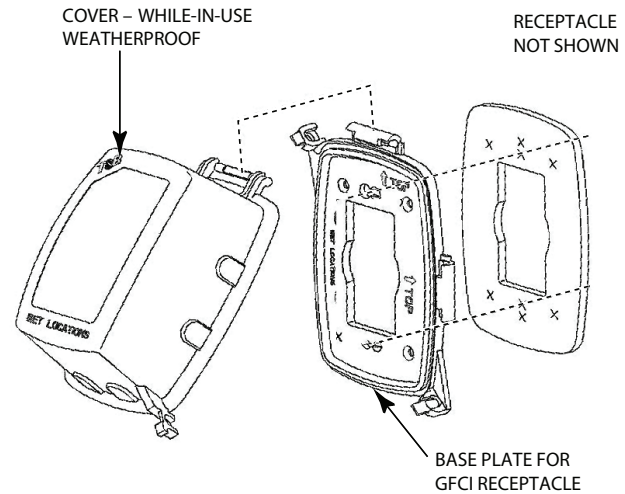
The weatherproof cover kit is shipped in the unit's control box. The kit includes the hinged cover, a backing plate and gasket.

**Disconnect all power to unit and convenience outlet. Lock-out and tag-out all power.**

Remove the blank cover plate at the convenience outlet; discard the blank cover.

Loosen the two screws at the GFCI duplex outlet, until approximately 1/2 in. (13 mm) under screw heads are exposed. Press the gasket over the screw heads. Slip the backing plate over the screw heads at the keyhole slots and align with the gasket; tighten the two screws until snug (do not over-tighten).

Mount the weatherproof cover to the backing plate as shown in Fig. 29. Remove two slot fillers in the bottom of the cover to permit service tool cords to exit the cover. Check for full closing and latching.



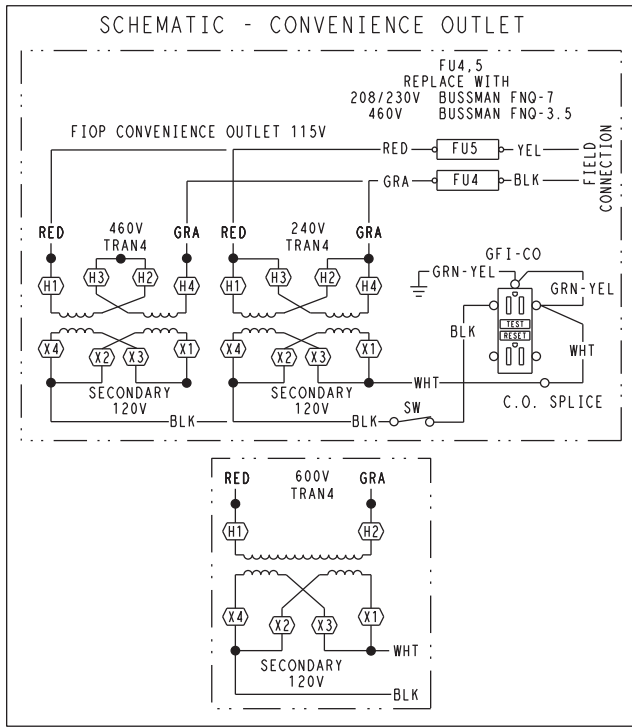
**Fig. 29 — Weatherproof Cover Installation**

**Non-powered type** — Requires the field installation of a general-purpose 125-volt 15-A circuit powered from a source elsewhere in the building. Observe national and local codes when selecting wire size, fuse or breaker requirements and disconnect switch size and location. Route 125-v power supply conductors into the bottom of the utility box containing the duplex receptacle.

**Unit-powered type** — A unit-mounted transformer which is factory-installed to step-down the main power supply voltage to the unit to 115-v at the duplex receptacle. This option also includes a manual switch with fuse, located in a utility box and mounted on a bracket behind the convenience outlet; access is through the unit's control box access panel. See Fig. 30.

The primary leads to the convenience outlet transformer are not factory-connected. If local codes permit, the transformer primary leads can be connected at the line-side terminals on the unit-mounted non-fused disconnect switch; this will provide service power to the unit when the unit disconnect switch is open. See Fig. 30. See Fig. 31 for convenience outlet utilization precautions.





UNIT VOLTAGE	CONNECT AS	PRIMARY CONNECTIONS	TRANSFORMER TERMINALS
208, 230	240	L1: RED+YEL L2: BLU+GRA	H1+H3 H2+H4
460	480	L1: RED Splice BLU+YEL L2: GRA	H1 H2+H3 H4
575	600	L1: RED L2: GRA	H1 H2

Fig. 30 — Powered Convenience Outlet Wiring

NOTICE/AVIS

Convenience Outlet Utilization

Maximum Intermittent Use 15 - Amps  
Maximum Continuous Use 8 - Amps  
Observe a 50% limit on the circuit  
Loading above 8 - Amps

---

Utilisation de la prise utilitaire

Usage intermittent maximum 15 - Amps  
Usage continu maximum 8 - Amps  
Observez une limite de 50% sur le circuit  
Chargement au-dessus de 8 - Amps

50HE501288 2.0

Fig. 31 — Convenience Outlet Utilization Notice

Test the GFCI receptacle by pressing the TEST button on the face of the receptacle to trip and open the receptacle. Check for proper grounding wires and power line phasing if the GFCI receptacle does not trip as required. Press the RESET button to clear the tripped condition.

Using unit-mounted convenience outlets: Units with unit-mounted convenience outlet circuits will often require that two disconnects be opened to de-energize all power to the unit. Treat all units as electrically energized until the convenience outlet power is also checked and de-energization is confirmed. Observe National Electrical Code Article 210, Branch Circuits, for use of convenience outlets.

## FACTORY-OPTION THRU-BASE CONNECTIONS —

All units are equipped with the ability to bring utilities through the base.

Gas is brought up through an embossed area located in the gas section behind the gas entrance post. Access is gained through the gas access panel. A knock out must be removed to accomplish this.

The electrical entrance is located in the control box area and can be accessed through the control box access panel. An embossed area is provided with three knock outs. High voltage is brought through the multi knock out by removing the appropriate size for the size of the fitting required. A 7/8-in. knock out is provided for the low voltage. An additional 7/8-in. knock out is provided for a 115 volt line which is used when the unit is equipped with the non-unit powered convenience outlet option.

All required fittings are field supplied. Install fittings when access to both top and bottom of the base pan is available. See electrical and gas connections for routing and connection information.

### Units Without Thru-Base Connections

1. Install liquid tight conduit between disconnect and control box.
2. Pull correctly rated high voltage wires through the conduit.
3. Install power lines to terminal connections as shown in Fig. 27.

**Field Control Wiring** — The 48TC unit requires an external temperature control device. This device can be a thermostat (field-supplied) or a PremierLink™ controller (available as factory-installed option or as field-installed accessory, for use on a Carrier Comfort Network® or as a stand alone control) or the RTU Open for Building Management Systems using non-CCN protocols (RTU Open is available as a factory-installed option only).

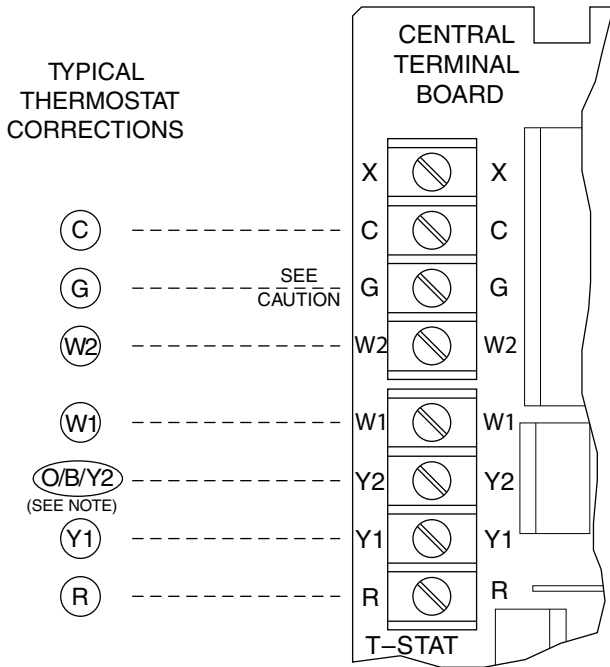
**Thermostat** — Install a Carrier-approved accessory 2-stage thermostat according to installation instructions included with the accessory. Locate the thermostat accessory on a solid wall in the conditioned space to sense average temperature in accordance with the thermostat installation instructions.

If the thermostat contains a logic circuit requiring 24-v power, use a thermostat cable or equivalent single leads of different colors with minimum of seven leads. If the thermostat does not require a 24-v source (no "C" connection required), use a thermostat cable or equivalent with minimum of six leads. Check the thermostat installation instructions for additional features which might require additional conductors in the cable.

For wire runs up to 50 ft (15 m), use no. 18 AWG (American Wire Gauge) insulated wire (35°C minimum). For 50 to 75 ft (15 to 23 m), use no. 16 AWG insulated wire (35°C minimum). For over 75 ft (23 m), use no. 14 AWG insulated wire (35°C minimum). All wire sizes larger than no. 18 AWG cannot be directly connected to the thermostat and will require a junction box and splice at the thermostat.

**Unit Without Thru-Base Connection Kit** — Correctly rated low voltage wire can be routed through the rubber grommet located on the corner post adjacent to the control box access panel. Route wire through the grommet and then route the wire behind the corner post utilizing the factory provided wire ties secured to the control box. This will ensure separation of the field low voltage wire and the high voltage circuit. Route the low voltage wire to the central terminal board. See Fig. 32.

NOTE: If utilizing the through the base connections, route the low voltage wire through the wire ties to the central terminal board.



NOTE: Typical multi-function marking. Follow manufacturer's configuration instructions to select Y2.

--- Field Wiring

contact set for dehumidification control. The humidistat is normally used in applications where a temperature control is already provided (units with PremierLink™ control).

To Connect the Carrier Humidistat (HL38MG029):

1. Route the humidistat 2-conductor cable (field-supplied) through the hole provided in the unit corner post.
2. Feed wires through the raceway built into the corner post (see Fig. 33) to the 24-v barrier located on the left side of the control box. The raceway provides the UL-required clearance between high-voltage and low-voltage wiring.
3. Use wire nuts to connect humidistat cable to two PINK leads in the low-voltage wiring as shown in Fig. 36.

To connect the Thermidistat device (33CS2PPRH- 01)

1. Route the Thermidistat multi-conductor thermostat cable (field-supplied) through the hole provided in the unit corner post.
2. Feed wires through the raceway built into the corner post (see Fig. 34) to the 24-v barrier located on the left side of the control box. The raceway provides the UL-required clearance between high-voltage and low-voltage wiring.
3. The Thermidistat has dry contacts at terminals D1 and D2 for dehumidification operation (see Fig. 37). The dry contacts must be wired between CTB terminal R and the PINK lead to the LTLO switch with field-supplied wire nuts. Refer to the installation instructions included with the Carrier Edge Thermidistat device for more information.

**CAUTION**

Failure to follow this caution may cause a short circuit. Carefully check the connection of control conductor for indoor fan control at terminal G. Connecting the indoor fan lead to terminal C will cause a short circuit condition which can cause component damage inside the unit or at the thermostat.

**Fig. 32 — Typical Low-Voltage Control Connections**

**Heat Anticipator Settings** — Set heat anticipator settings at 0.14 amp for the first stage and 0.14 amp for second-stage heating.

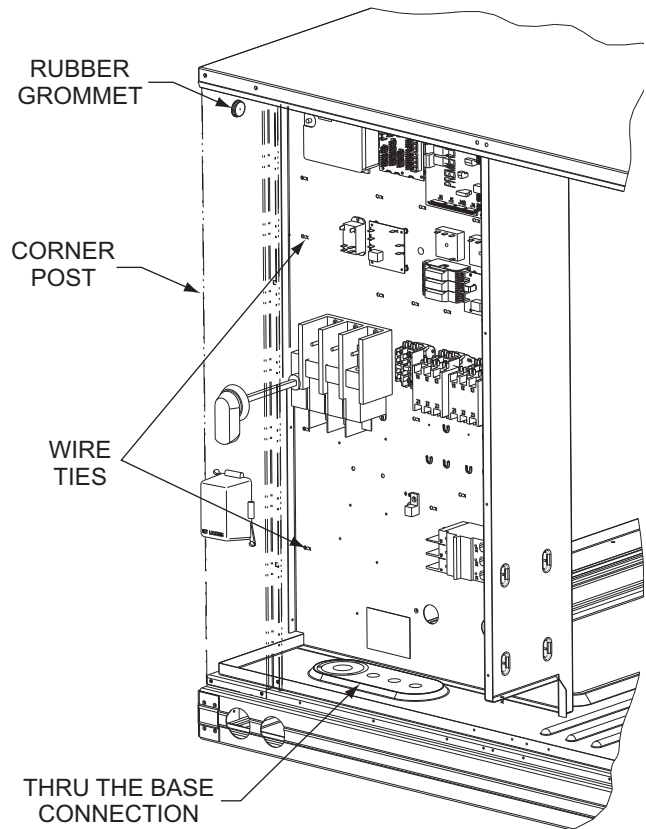
**Transformer Connection for 208-v Power Supply** — All units except 208/230-v units are factory wired for the voltage shown on the nameplate. If the 208/230-v unit is to be connected to a 208-v power supply, the control transformer must be re-wired by moving the black wire with the 1/4-in. female spade connector from the 230-v connection and moving it to the 208-v 1/4-in. male terminal on the primary side of the transformer. Refer to unit label diagram for additional information.

**Humidi-MiZer® Control Connections**

HUMIDI-MIZER – SPACE RH CONTROLLER

NOTE: The Humidi-MiZer system is a factory installed option.

The Humidi-MiZer dehumidification system requires a field-supplied and installed space relative humidity control device. This device may be a separate humidistat control (contact closes on rise in space RH above control setpoint) (see Fig. 34) or a combination thermostat-humidistat control device such as Carrier's Edge® Pro Thermidistat (see Fig. 35) with isolated



**Fig. 33 — Field Control Wiring Raceway**

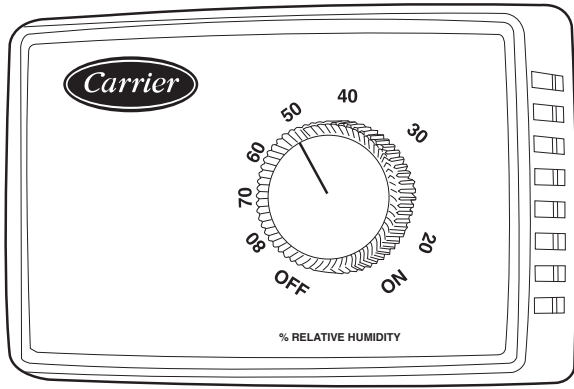


Fig. 34 — Accessory Field-Installed Humidistat



Fig. 35 — Edge Pro Thermidistat

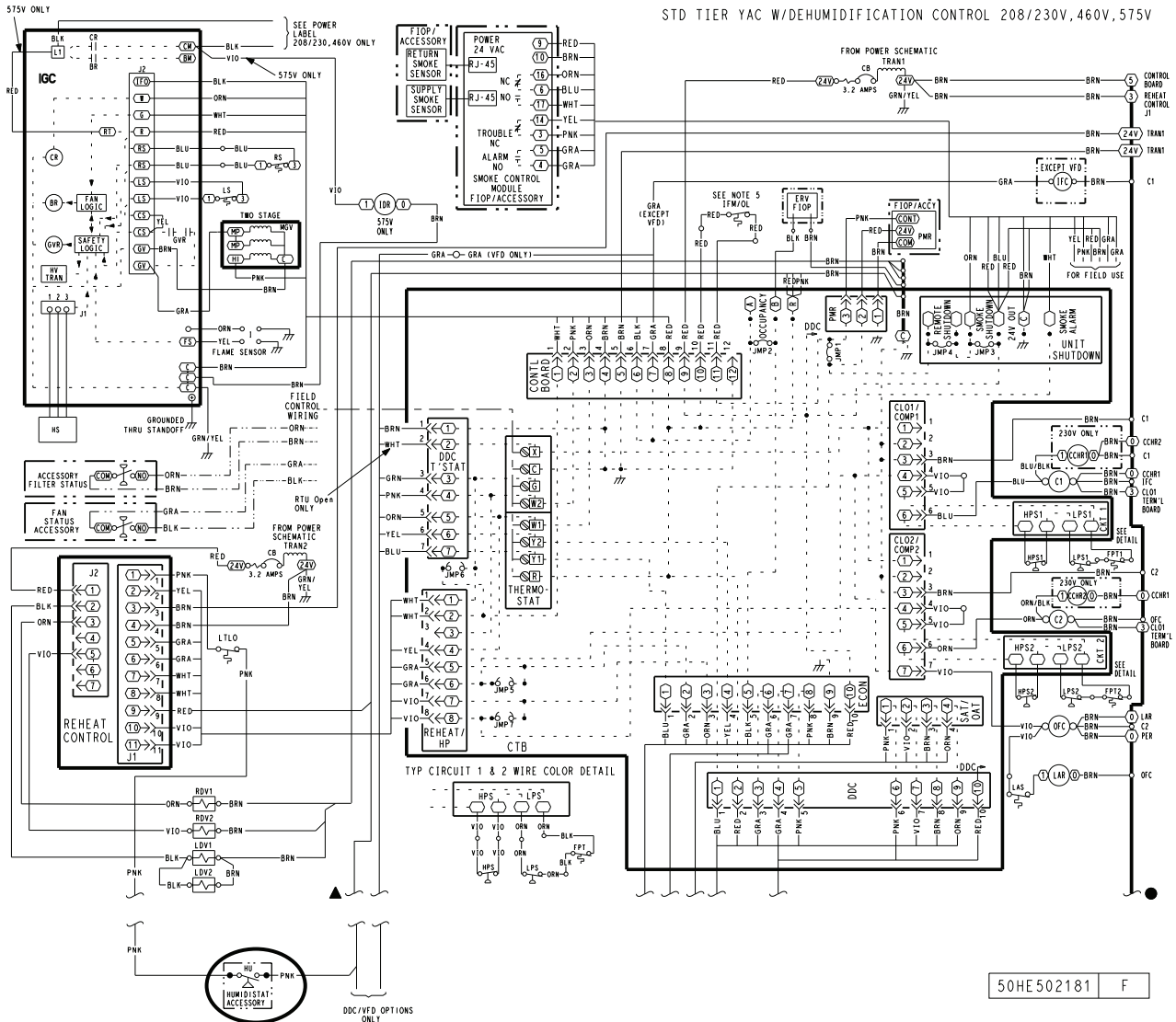
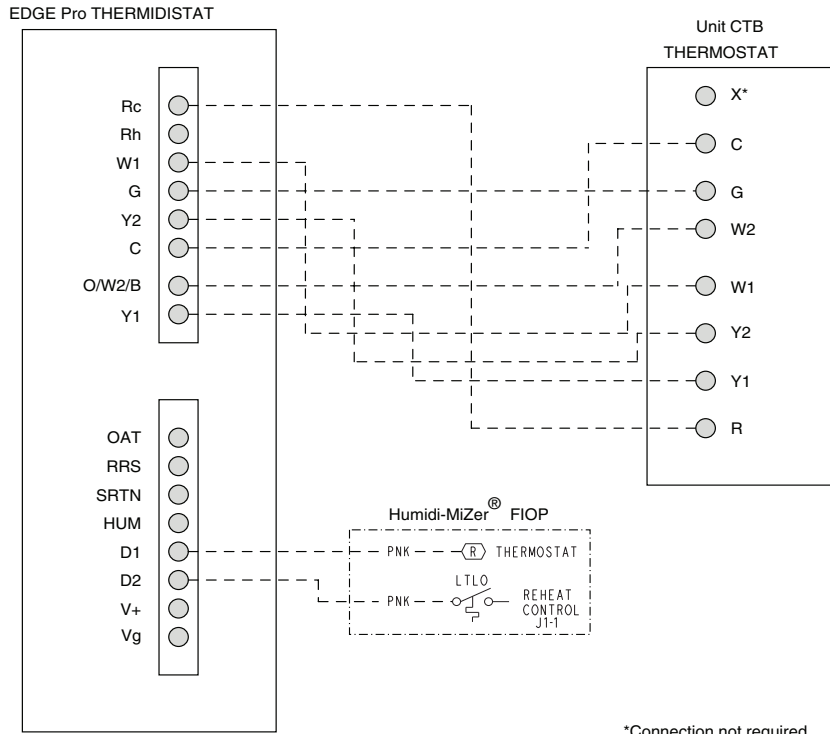


Fig. 36 — Typical Humidi-MiZer® Adaptive Dehumidification System Humidistat Wiring



**Fig. 37 — Typical Rooftop Unit with Humidi-MiZer® Adaptive Dehumidification System with Edge® Pro Thermidistat Device**

**Staged Air Volume (SAV™) with Variable Frequency Drive (Factory-Installed Option)** — For details on operating 48TC 2 stage cooling units equipped with the factory installed Stage Air Volume option, refer to the Variable Frequency Drive (VFD) Installation, Setup, and Troubleshooting Supplement.

**EconoMiSer® X (Factory-Installed Option)**

**PRODUCT DESCRIPTION** — The EconoMiSer X system is an expandable economizer control system, which includes a W7220 economizer module (controller) with an LCD and keypad (see Fig. 38). The W7220 can be configured with optional sensors.



**Fig. 38 — W7220 Economizer Module**

The W7220 economizer module can be used as a stand-alone economizer module wired directly to a commercial set-back space thermostat and sensors to provide Outside Air dry-bulb economizer control.

The W7220 economizer module can be connected to optional sensors for single or differential enthalpy control. The W7220 economizer module provides power and communications for the sensors.

The W7220 economizer module automatically detects sensors by polling to determine which sensors are present. If a sensor loses communications after it has been detected, the W7220 economizer controller indicates a device fail error on its LCD.

**SYSTEM COMPONENTS** — The EconoMiSer X system includes an economizer module, 20k mixed air sensor, damper actuator, and either a 20k outdoor air temperature sensor or S-Bus enthalpy sensors.

**Economizer Module** is the core of the EconoMiSer X system. The module is mounted in the unit’s control box, and includes the user interface for the system. The W7220 economizer module provides the basic inputs and outputs to provide simple economizer control. When used with the optional sensors, the economizer module provides more advanced economizer functionality.

**S-Bus Enthalpy Control Sensors** are a combination temperature and humidity sensor which is powered by and communicates on the S-Bus. Up to three sensors may be configured with the W7220 economizer module. See page 27 for details.

**CO<sub>2</sub> Sensor (optional)** can be added for Demand Controlled Ventilation (DCV).

**SPECIFICATIONS**

**W7220 Economizer Module** is designed for use with 2 to 10 Vdc or bus communicating actuator. The module includes terminals for CO<sub>2</sub> sensor, Mixed Air sensor, and an outdoor dry bulb sensor. Enthalpy and other options are available with bus sensors.

**User Interface** provides status for normal operation, setup parameters, checkout tests, and alarm and error conditions with a 2-line 16 character LCD display and four button keypad.

**Electrical**

Rated Voltage — 20 to 30 Vac RMS, 50/60 Hz

Transformer — 100 va maximum system input

Nominal Power Consumption (at 24 Vac, 60 Hz) — 11.5 VA without sensors or actuators

Relay Digital Output Rating at 30 Vac (maximum power from Class 2 input only) — 1.5A RUN:

3.5A inrush at 0.45PF (200,000 cycles) or

7.5A inrush at 0.45PF (100,000 cycles)

External Sensors Power Output — 21 Vdc ± 5% at 48mA

**IMPORTANT:** All inputs and outputs must be Class 2 wiring.

## INPUTS

### Sensors

NOTE: A Mixed Air (MA) analog sensor is required on all W7220 units; either an Outdoor Air (OA) sensor for dry bulb change over or an OA bus sensor for outdoor enthalpy change over is required in addition to the MA sensor. An additional Return Air (RA) bus sensor can be added to the system for differential enthalpy or dry bulb changeover. For differential dry bulb changeover a 20k ohm sensor is required in the OA and a bus sensor in the RA. DIP switch on RA bus sensor must be set in the RA position.

*Dry Bulb Temperature (optional) and Mixed Air (required), 20k NTC*

2-wire (18 to 22 AWG);

Temperature range -40 to 150°F (-40 to 65°C)

Temperature accuracy -0°F/+2°F

*Temperature and Humidity, C7400S1000 (optional)*

S-Bus; 2-wire (18 to 22 AWG)

Temperature: range -40 to 150°F (-40 to 65°C)

Temperature accuracy -0°F/+2°F

Humidity: range 0 to 100% RH with 5% accuracy.

NOTE: Up to three (3) S-Bus sensors may be connected to the W7220 economizer module. For outdoor air (OA), return air (RA) and discharge (supply) air (DA).

*4 Binary Inputs* — 1-wire 24 Vac + common GND (see page 27 for wiring details). 24 Vac power supply: 20 to 30 Vac 50/60 Hz; 100 VA Class 2 transformer.

## OUTPUTS

**Actuator Signal:** 2-10 Vdc; minimum actuator impedance is 2k ohm; bus two-wire output for bus communicating actuators.

**Exhaust fan, Y1, Y2 and AUX1 O:**

All Relay Outputs (at 30 Vac):

Running: 1.5A maximum

Inrush: 7.5A maximum

## ENVIRONMENTAL

**Operating Temperature:**

-40 to 150°F (-40 to 65°C).

Exception of display operation down to -4°F with full recovery at -4°F from exposure to -40°F

**Storage Temperature:**

-40 to 150°F (-40 to 65°C)

**Shipping Temperature:**

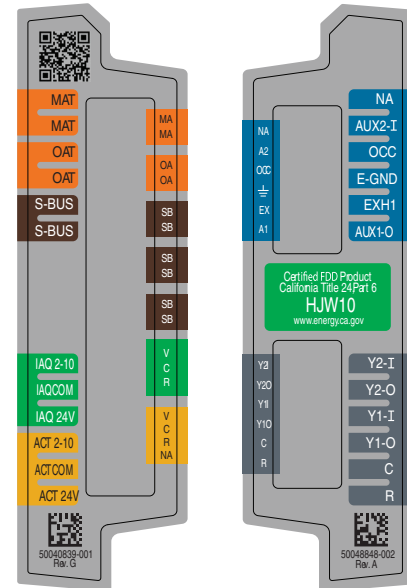
-40 to 150°F (-40 to 65°C)

## Relative Humidity:

5% to 95% RH non-condensing

**ECONOMIZER MODULE WIRING DETAILS** — Use Fig. 39 and Tables 6 and 7 to locate the wiring terminals for the Economizer module.

NOTE: The four terminal blocks are removable. You can slide out each terminal block, wire it, and then slide it back into place.



**Fig. 39 — W7220 Wiring Terminals**

**S-BUS SENSOR WIRING** — The labels on the sensors and controller are color coded for ease of installation. Orange labeled sensors can only be wired to orange terminals on the controller. Brown labeled sensors can only be wired to S-bus (brown) terminals. Use Fig. 40 and Table 8 to locate the wiring terminals for each S-Bus sensor.

Use Fig. 40 and Table 9 to set the DIP switches for the desired use of the sensor.

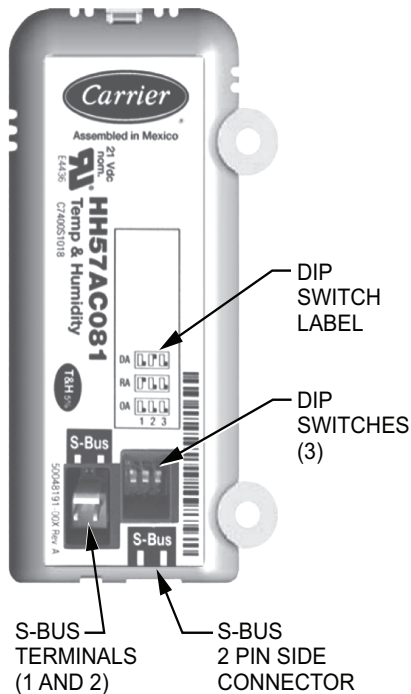
**Table 6 — Economizer Module - Left Hand Terminal Blocks**

LABEL	TYPE	DESCRIPTION
<b>Top Left Terminal Block</b>		
MAT MAT	20k NTC and COM	Mixed Air Temperature Sensor (Polarity Insensitive Connection)
OAT OAT	20k NTC and COM	Outdoor Air Temperature Sensor (Polarity Insensitive Connection)
S-BUS S-BUS	S-BUS (Syk Bus)	Enthalpy Control Sensor (Polarity Insensitive Connection)
<b>Bottom Left Terminal Block</b>		
IAQ 2-10	2-10 vdc	Air Quality Sensor Input (e.g. CO <sub>2</sub> sensor)
IAQ COM	COM	Air Quality Sensor Common
IAQ 24V	24 vac	Air Quality Sensor 24 vac Source
ACT 2-10	2-10 vdc	Damper Actuator Output (2-10 vdc)
ACT COM	COM	Damper Actuator Output Common
ACT 24v	24 vac	Damper Actuator 24 vac Source



**Table 7 — Economizer Module - Right Hand Terminal Blocks**

LABEL	TYPE	DESCRIPTION
<b>Top Right Terminal Blocks</b>		
AUX2 I	24 vac IN	The first terminal is not used.
OCC	24 vac IN	Shut Down (SD) or HEAT (W) Conventional only and Heat Pump Changeover (O-B) in Heat Pump mode.
E-GND	E-GND	Occupied/Unoccupied Input
EXH1	24 vac OUT	Exhaust Fan 1 Output
AUX1 O	24 vac OUT	Programmable: Exhaust fan 2 output or ERV or System alarm output
<b>Bottom Right Terminal Blocks</b>		
Y2-I	24 vac IN	Y2 in - Cooling Stage 2 Input from space thermostat
Y2-O	24 vac OUT	Y2 out - Cooling Stage 2 Output to stage 2 mechanical cooling
Y1-I	24 vac IN	Y1 in - Cooling Stage 2 Input from space thermostat
Y1-O	24 vac OUT	Y1 out - Cooling Stage 2 Output to stage 2 mechanical cooling
C	COM	24 vac Common
R	24 vac	24 vac Power (hot)



**Fig. 40 — S-Bus Sensor DIP Switches**

Use Fig. 40 and Table 8 to locate the wiring terminals for each enthalpy control sensor.

**Table 8 — HH57AC081 Sensor Wiring Terminations**

TERMINAL		TYPE	DESCRIPTION
NUMBER	LABEL		
1	S-BUS	S-BUS	S-BUS Communications (Enthalpy Control Sensor Bus)
2	S-BUS	S-BUS	S-BUS Communications (Enthalpy Control Sensor Bus)

Use Fig. 40 and Table 9 to set the DIP switches for the desired use of the sensor.

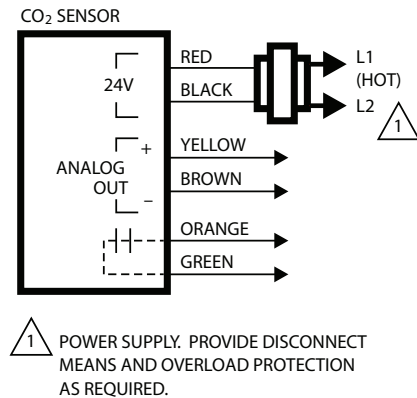
**Table 9 — HH57AC081 Sensor DIP Switch**

USE	DIP SWITCH POSITIONS FOR SWITCHES 1, 2, AND 3		
	1	2	3
DA	OFF	ON	OFF
RA	ON	OFF	OFF
OA	OFF	OFF	OFF

NOTE: When a S-bus sensor is connected to an existing network, it will take 60 minutes for the network to recognize and auto-configure itself to use the new sensor.

During the 60 minute setup period, no alarms for sensor failures (except SAT) will be issued and no economizing function will be available.

CO<sub>2</sub> SENSOR WIRING — When using a CO<sub>2</sub> sensor the black and brown common wires are internally connected and only one is connected to “IAQ COM” on the W7220. Use the power from the W7220 to power the CO<sub>2</sub> sensor OR make sure the ground for the power supplies are common. See Fig. 41 for CO<sub>2</sub> sensor wiring.



**Fig. 41 — CO<sub>2</sub> Sensor Wiring**

INTERFACE OVERVIEW — This section describes how to use the economizer’s user interface for:

- Keypad and menu navigation
- Settings and parameter changes
- Menu structure and selection

USER INTERFACE — The user interface consists of a 2-line LCD display and a 4-button keypad on the front of the economizer controller.

KEYPAD — The four navigation buttons (see Fig. 42) are used to scroll through the menus and menu items, select menu items, and to change parameter and configuration settings.

To use the keypad when working with menus:

- Press the ▲ (Up arrow) button to move to the previous menu.
- Press the ▼ (Down arrow) button to move to the next menu.





**Table 10 — Menu Structure**

MENU	PARAMETER	PARAMETER DEFAULT VALUE	PARAMETER RANGE AND INCREMENT	NOTES
STATUS	ECONO AVAIL	NO	YES/NO	FIRST STAGE COOLING DEMAND (Y1-IN) YES = economizing available; the system can use outside air for free cooling when required
	ECONOMIZING	NO	YES/NO	FIRST STAGE COOLING RELAY OUTPUT YES = outside air being used for 1 stage cooling
	OCCUPIED	NO	YES/NO	OCCUPIED YES = OCC signal received from space thermostat or unitary controller YES = 24 Vac on terminal OCC NO = 0 Vac on terminal OCC
	HEAT PUMP	N/A	COOL HEAT	HEAT PUMP MODE Displays COOL or HEAT when system is set to heat pump (Non-conventional)
	COOL Y1—IN	OFF	ON/OFF	FIRST STAGE COOLING DEMAND (Y1-IN) Y1-I signal from space thermostat or unitary controller for cooling stage 1. ON = 24 Vac on terminal Y1-I OFF = 0 Vac on terminal Y1-I
	COOL Y1—OUT	OFF	ON/OFF	FIRST STAGE COOLING RELAY OUTPUT Cool stage 1 Relay Output to stage 1 mechanical cooling (Y1-OUT terminal)
	COOL Y2—IN	OFF	ON/OFF	SECOND STAGE COOLING DEMAND (Y2-IN) Y2-I signal from space thermostat our unitary controller for second stage cooling. ON = 24 Vac on terminal Y2-I OFF = 0 Vac on terminal Y2-I
	COOL Y2—OUT	OFF	ON/OFF	SECOND STAGE COOLING RELAY OUTPUT Cool Stage 2 Relay Output to mechanical cooling (Y2-OUT terminal)
	MA TEMP	___ . _ F	0 to 140°F	SUPPLY AIR TEMPERATURE, Cooling Mode Displays value of measured mixed air from MAT sensor. Displays ___ . _ F if not connected, short or out-of-range.
	DA TEMP	___ . _ F	0 to 140°F	DISCHARGE AIR TEMPERATURE, after Heating section Displays when Discharge Air sensor is connected and displays measured discharge temperature. Displays ___ . _ F if sensor sends invalid value, if not connected, short or out-of-range.
	OA TEMP	___ . _ F	-40 to 140°F	OUTSIDE AIR TEMP Displays measured value of outdoor air temperature. Displays ___ . _ F if sensor sends invalid value, short or out-of-range.
	OA HUM	__ %	0 to 100%	OUTSIDE AIR RELATIVE HUMIDITY Displays measured value of outdoor humidity from OA sensor. Displays __ % if not connected short, or out-of-range.
	RA TEMP	___ . _ F	0 to 140°F	RETURN AIR TEMPERATURE Displays measured value of return air temperature from RAT sensor. Displays ___ . _ F if sensor sends invalid value, if not connected, short or out-of-range
	RA HUM	__ %	0 to 100%	RETURN AIR RELATIVE HUMIDITY Displays measured value of return air humidity from RA sensor. Displays __ % if sensor sends invalid value, if not connected, short or out-of-range
	IN CO2	___ ppm	0 to 2000 ppm	SPACE/RETURN AIR CO2 Displays value of measured CO <sub>2</sub> from CO <sub>2</sub> sensor. Invalid if not connected, short or out-of-range
	DCV STATUS	N/A	ON/OFF	DEMAND CONTROLLED VENTILATION STATUS Displays ON if above setpoint and OFF if below setpoint, and ONLY if a CO <sub>2</sub> sensor is connected.
	DAMPER OUT	2.0v	2.0 to 10.0v	Displays voltage output to the damper actuator.
	ACT POS	N/A	0 to 100%	Displays actual position of outdoor air damper actuator

**Table 10 — Menu Structure (cont)**

MENU	PARAMETER	PARAMETER DEFAULT VALUE	PARAMETER RANGE AND INCREMENT	NOTES
STATUS (CONT)	ACT COUNT	N/A	1 to 65535	Displays number of times actuator has cycled. 1 cycles equals 180 deg. of actuator movement in any direction.
	ACTUATOR	N/A	OK/Alarm (on Alarm menu)	Displays ERROR if voltage or torque is below actuator range.
	EXH1 OUT	OFF	ON/OFF	EXHAUST STAGE 1 RELAY OUTPUT Output of EXH1 terminal: ON = relay closed OFF = relay open
	EXH2 OUT	OFF	ON/OFF	EXHAUST STAGE 2 RELAY OUTPUT Output of AUX terminal; displays only if AUX = EXH2
	ERV	OFF	ON/OFF	ENERGY RECOVERY VENTILATOR Output of AUX terminal; displays only if AUX = ERV
	MECH COOL ON or HEAT STAGES ON	0	0, 1, or 2	Displays stage of mechanical cooling that is active. Displays the stage of heat pump heating that is active.
	FAN SPEED	N/A	LOW or HIGH	SUPPLY FAN SPEED Displays speed setting of fan on a 2-speed fan unit.
	W (HEAT ON)	N/A	ON/OFF	HEAT DEMAND STATUS Displays status of heat demand on a 2-speed fan unit.
SETPOINTS	MAT SET	53F	38 to 65F; increment by 1	SUPPLY AIR SETPOINT Setpoint determines where the economizer will modulate the OA damper to maintain the mixed air temperature.
	LOW T LOCK	32F	-45 to 80°F; increment by 1	COMPRESSOR LOW TEMPERATURE LOCKOUT Setpoint determines outdoor temperature when the mechanical cooling cannot be turned on. Commonly referred to as the Compressor lockout.
	DRYBLB SET	63F	48 to 80°F; increment by 1	OA DRY BULB TEMPERATURE CHANGEOVER SETPOINT Setpoint determines where the economizer will assume outdoor air temperature is good for free cooling; e.g.; at 63°F unit will economize at 62°F and below and not economize at 64°F and above. There is a 2°F deadband.
	ENTH CURVE	ES3	ES1,ES2,ES3,ES4, or ES5	ENTHALPY CHANGEOVER CURVE Enthalpy boundary "curves" for economizing using single enthalpy.
	DCV SET	1100ppm	500 to 2000ppm; increment by 100	DEMAND CONTROLLED VENTILATION Displays only if CO <sub>2</sub> sensor is connected. Setpoint for Demand Control Ventilation of space. Above the setpoint, the OA dampers will modulate open to bring in additional OA to maintain a space ppm level below the setpoint.
	MIN POS	2.8 V	2 to 10 Vdc	VENTILATION MINIMUM POSITION Displays ONLY if a CO <sub>2</sub> sensor is NOT connected.
	VENTMAX With 2-speed fan units VENTMAX L (low speed fan) and VENTMAX H (high speed fan) settings are required	2.8 V	2 to 10 Vdc	DCV MAXIMUM DAMPER POSITION Displays only if a CO <sub>2</sub> sensor is connected. Used for Vbz (ventilation max cfm) setpoint. Displays 2 to 10 V if <3 sensors (RA, OA, and MA). In AUTO mode dampers controlled by CFM.
			100 to 9990 cfm; increment by 10	If OA, MA, RA, and CO <sub>2</sub> sensors are connected and DCV CAL ENABLE is set to AUTO mode, the OA dampers are controlled by CFM and displays from 100 to 9990 CFM.
			2 to 10 Vdc	With 2-speed fan units VENT L (low speed fan) and MIN POS H (high speed fan) settings are required. Default for VENTMAX L is 3.2V and VENTMAX H is 2.8V
	VENTMIN With 2-speed fan units VENTMIN L (low speed fan) and VENTMIN H (high speed fan) set	2.25 V	2 to 10 Vdc or 100 to 9990 cfm increment by 10	DCV MINIMUM DAMPER POSITION Displays only if a CO <sub>2</sub> sensor is connected. Used for Ba (ventilation min cfm) setpoint. Displays 2 to 10 V if <3 sensors (RA, OA, and MA). Va is only set if DCV is used. This is the ventilation for less than maximum occupancy of the space. In AUTO mode dampers controlled by CFM.
			100 to 9990 cfm; increment by 10	If OA, MA, RA, and CO <sub>2</sub> sensors are connected and DCV CAL ENABLE is set to AUTO mode, the OA dampers are controlled by CFM and displays from 100 to 9990 CFM.
			2 to 10 Vdc	With 2-speed fan units VENTMIN L (low speed fan) and MIN POS H (high speed fan) settings are required. Default for VENTMIN L is 3.2V and VENTMIN H is 2.8V
ERV OAT SP	32°F	0 to 50°F; increment by 1	ENERGY RECOVERY VENTILATOR UNIT OUTDOOR AIR TEMPERATURE SETPOINT Only when AUX1 O = ERV	
EXH1 SET With 2-speed fan units Exh1 L (low speed fan) and Exh1 H (high speed fan) settings are required	50%	0 to 100%; increment by 1	EXHAUST FAN STAGE 1 SETPOINT Setpoint for OA damper position when exhaust fan 1 is powered by the economizer. With 2-speed fan units Exh1 L (low speed fan) and Exh1 H (high speed fan) settings are required. Default for Exh1 L is 65% and Exh1 H is 50%	
EXH2 SET With 2-speed fan units Exh2 L (low speed fan) and Exh2 H (high speed fan) settings are required	75%	0 to 100%; increment by 1	EXHAUST FAN STAGE 2 SETPOINT Setpoint for OA damper position when exhaust fan 2 is powered by the economizer. Only used when AUX1 O is set to EXH2. With 2-speed fan units Exh2 L (low speed fan) and Exh2 H (high speed fan) settings are required. Default for Exh2 L is 80% and Exh2 H is 75%	

**Table 10 — Menu Structure (cont)**

MENU	PARAMETER	PARAMETER DEFAULT VALUE	PARAMETER RANGE AND INCREMENT	NOTES
SYSTEM SETUP	INSTALL	01/01/10	N/A	Display order = MM/DD/YY Setting order = DD, MM, then YY.
	UNITS DEG	F	F or C	Sets economizer controller in degrees Fahrenheit or Celsius
	EQUIPMENT	CONV	Conventional or HP	CONV = conventional; HP O/B = Enable Heat Pump mode. Use AUX2 I for Heat Pump input from thermostat or controller. See Menu Note 7.
	AUX2 IN	W	SD/W or HP(O)/HP(B)	In CONV mode: SD + Enables configuration of shutdown (default); W = Informs controller that system is in heating mode. NOTE: If using 2-speed fan mode, you must program CONV mode for W. Shutdown is not available in 2-speed fan mode. See Menu Note 7. In HP O/B mode: HP(O) = energize heat pump on Cool (default); HP(B) = energize heat pump on heat.
	FAN SPEED	2 speed	1 speed/2 speed	Sets the economizer controller for operation of 1 speed or 2 speed supply fan. NOTE: 2-speed fan option also needs Heat (W1) programmed in AUX 2 In. See Menu Note 7.
	FAN CFM	5000cfm	100 to 15000 cfm; increment by 100	UNIT DESIGN AIRFLOW (CFM) Enter only if using DCVAL ENA = AUTO The value is found on the nameplate label for the specific unit.
	AUX1 OUT	NONE	NONE ERV EXH2 SYS	Select OUTPUT for AUX1 O relay • NONE = not configured (output is not used) • ERV = Energy Recovery Ventilator • EXH2 = second damper position relay closure for second exhaust fan • SYS = use output as an alarm signal
	OCC	INPUT	INPUT or ALWAYS	OCCUPIED MODE BY EXTERNAL SIGNAL When using a setback thermostat with occupancy out (24 vac), the 24 vac is input "INPUT" to the OCC terminal. If no occupancy output from the thermostat then change program to "ALWAYS" OR add a jumper from terminal R to OCC terminal.
	FACTORY DEFAULT	NO	NO or YES	Resets all set points to factory defaults when set to YES. LCD will briefly flash YES and change to NO but all parameters will change to the factory default values. NOTE: RECHECK AUX2 IN and FANTYPE for required 2-speed values.
ADVANCED SETUP	MA LO SET	45°F	35 to 55°F; Incremented by 10	SUPPLY AIR TEMPERATURE LOW LIMIT Temperature to achieve Freeze Protection (close damper and alarm if temperature falls below setup value).
	FREEZE POS	CLO	CLO or MIN	FREEZE PROTECTION DAMPER POSITION Damper position when freeze protection is active (closed or MIN POS).
	CO2 ZERO	0ppm	0 to 500 ppm; Increment by 10	CO <sub>2</sub> ppm level to match CO <sub>2</sub> sensor start level.
	CO2 SPAN	2000ppm	1000 to 3000 ppm; Increment by 10	CO <sub>2</sub> ppm span to match CO <sub>2</sub> sensor.
	STG3 DLY	2.0h	0 min, 5 min, 15 min, then 15 min intervals. Up to 4 hrs or OFF	COOLING STAGE 3 DELAY Delay after stage 2 cool has been active. Turns on second stage of cooling when economizer is first stage and mechanical cooling is second stage. Allows three stages of cooling, 1 economizer and 2 mechanical. OFF = no Stage 3 cooling
	SD DMPR POS	CLO	CLO or OPN	Indicates shutdown signal from space thermostat or unitary controller. When controller receives 24 Vac input on the SD terminal in conventional mode, the OA damper will open if programmed for OPN and OA damper will close if programmed for CLO. All other controls, e.g., fans, etc. will shut off.
	DA LO ALM	45 F (7 C)	35 to 65°F; (2 to 18 C) Incremented by 5 deg.	Used for alarm for when the DA air temperature is too low. Set lower range of alarm, Below this temperature the alarm will show on the display.
	DA HI ALM	80 F (27 C)	70 to 180°F; (21 to 82 C) Incremented by 5 deg.	Used for alarm for when the DA air temperature is too high. Set higher range of alarm, Above this temperature the alarm will show on the display.
	DCVCAL ENA	MAN	MAN (manual) AUTO	Turns on the DCV automatic control of the dampers. Resets ventilation based on the RA, OA, and MA sensor conditions. Requires all 3 RA, OA, and MA sensors.

**Table 10 — Menu Structure (cont)**

MENU	PARAMETER	PARAMETER DEFAULT VALUE	PARAMETER RANGE AND INCREMENT	NOTES
<b>ADVANCED SETUP (CONT)</b>	MAT T CAL	0.0°F	±2.5°F	SUPPLY AIR TEMPERATURE CALIBRATION Allows for the operator to adjust for an out of calibration temperature sensor.
	OAS T CAL	0.0°F	±2.5°F	OUTSIDE AIR TEMPERATURE CALIBRATION Allows for the operator to adjust for an out of calibration temperature sensor.
	OA H CAL	0% RH	±10% RH	OUTSIDE AIR HUMIDITY CALIBRATION Allows for operator to adjust for an out of calibration humidity sensor.
	RA T CAL	0.0°F	±2.5°F	RETURN AIR TEMPERATURE CALIBRATION Allows for the operator to adjust for an out of calibration temperature sensor.
	RA H CAL	0% RH	±10% RH	RETURN AIR HUMIDITY CALIBRATION Allows for operator to adjust for an out of calibration humidity sensor.
	DA T CAL	0.0°F	±2.5°F	DISCHARGE AIR TEMPERATURE CALIBRATION Allows for the operator to adjust for an out of calibration temperature sensor.
	2SP FAN DELAY	5 Minutes	0 to 20 minutes in 1 minute increments	TIME DELAY ON 2nd STAGE ECONOMIZING When in economizing mode this is the delay for the high speed fan to try to satisfy the call for second stage cooling before the first stage mechanical cooling is enabled.
<b>CHECKOUT</b>	DAMPER MINIMUM POSITION	N/A	N/A	The checkout for the damper minimum position is based on the system. See Table 11.
	DAMPER OPEN	N/A	N/A	Position damper to the full open position. Exhaust fan contacts enable during the DAMPER OPEN test. Make sure you pause in the mode to allow exhaust contacts to energize due to the delay in the system.
	DAMPER CLOSE	N/A	N/A	Positions damper to the fully closed position
	CONNECT Y1-O	N/A	N/A	Closes the Y1-O relay (Y1-O)
	CONNECT Y2-O	N/A	N/A	Closes the Y2-O relay (Y2-O)
	CONNECT AUX1-O	N/A	N/A	Energizes the AUX output. If Aux setting is: • NONE — not action taken • ERV — 24 Vac out. Turns on or signals an ERV that the conditions are not good for economizing but are for ERV operation. • SYS — 24 Vac out. Issues a system alarm
	CONNECT EXH1	N/A	N/A	Closes the power exhaust fan 2 relay (EXH1)
<b>ALARMS</b>	Alarms display only when they are active. The menu title "ALARMS(#)" includes the number of active alarms in parenthesis ( ). When using SYLK bus sensors, "SYLK" will appear on the screen, and when using 20k OA temperature sensors, "SENS T" will appear on the screen			
	MA T SENS ERR	N/A	N/A	SUPPLY AIR TEMPERATURE SENSOR ERROR Mixed air sensor has failed or become disconnected - check wiring then replace sensor if the alarm continues.
	CO2 SENS ERR	N/A	N/A	CO <sub>2</sub> SENSOR ERROR CO <sub>2</sub> sensor has failed, gone out of range or become disconnected - check wiring then replace sensor if the alarm continues.
	OA SYLK T ERR	N/A	N/A	OUTSIDE AIR S-BUS SENSOR ERROR Outdoor air enthalpy sensor has failed or become disconnected - check wiring then replace sensor if the alarm continues.
	OA SYLK H ERR	N/A	N/A	
	RA SYLK T ERR	N/A	N/A	RETURN AIR S-BUS SENSOR ERROR Return air enthalpy sensor has failed or become disconnected - check wiring then replace sensor if the alarm continues.
	RA SYLK H ERR	N/A	N/A	
	DA SYLK T ERR	N/A	N/A	DISCHARGE AIR S-BUS SENSOR ERROR Discharge air sensor has failed or become disconnected - check wiring then replace sensor if the alarm continues.
	OA SENS T ERR	N/A	N/A	OUTSIDE AIR TEMPERATURE SENSOR ERROR Outdoor air temperature sensor has failed or become disconnected - check wiring then replace if the alarm continues.
	ACT ERROR	N/A	N/A	ACTUATOR ERROR Actuator has failed or become disconnected - check for stall, over voltage, under voltage and actuator count. Replace actuator if damper is movable and supply voltage is between 21.6 V and 26.4 V. Check actuator count on STATUS menu.
FREEZE ALARM	N/A	N/A	Check if outdoor temperature is below the LOW Temp Lockout on setpoint menu. Check if Mixed air temperature on STATUS menu is below the Lo Setpoint on Advanced menu. When conditions are back in normal range then the alarm will go away.	



**Table 10 — Menu Structure (cont)**

MENU	PARAMETER	PARAMETER DEFAULT VALUE	PARAMETER RANGE AND INCREMENT	NOTES
<b>ALARMS (CONT)</b>	SHUTDOWN ACTIVE	N/A	N/A	AUX2 IN is programmed for SHUTDOWN and 24 V has been applied to AUX 2IN terminal.
	DMP CAL RUNNING	N/A	N/A	<b>DAMPER CALIBRATION ROUTINE RUNNING</b> If DCV Auto enable has been programmed, when the W7220 is completing a calibration on the dampers, this alarm will display. Wait until the calibration is completed and the alarm will go away. Must have OA, MA and RA sensors for DCV calibration; set up in the Advanced setup menu.
	DA SENS ALM	N/A	N/A	<b>DISCHARGE AIR TEMPERATURE SENSOR ALARM</b> Discharge air temperature is out of the range set in the ADVANCED SETUP Menu. Check the temperature of the discharge air.
	SYS ALARM	N/A	N/A	When AUX1-0 is set to SYS and there is any alarm (e.g., failed sensors, etc.), the AUX1-0 terminal has 24 Vac out.
	ACT UNDER V	N/A	N/A	<b>ACTUATOR VOLTAGE LOW</b> Voltage received by actuator is above expected range.
	ACT OVER V	N/A	N/A	<b>ACTUATOR VOLTAGE HIGH</b> Voltage received by actuator is below expected range.
	ACT STALLED	N/A	N/A	<b>ACTUATOR STALLED</b> Actuator stopped before achieving commanded position.

**LEGEND**

- CLO** — Compressor Lockout
- DCV** — Demand Controlled Ventilation
- ERV** — Energy Recovery Ventilator
- LCD** — Liquid Crystal Display
- MA** — Mixed Air
- MAT** — Mixed Air Temperature
- N/A** — Not Applicable
- OA** — Outdoor Air
- OAT** — Outdoor Air Temperature
- OCC** — Occupied
- RA** — Return Air
- RAT** — Return Air Temperature
- RTU** — Rooftop Unit
- SYS** — System

**NOTES:**

1. Table 10 illustrates the complete hierarchy. Your menu parameters may be different depending on your configuration. For example if you do not have a DCV (CO<sub>2</sub>) sensor, then none of the DCV parameters appear.
2. When values are displayed, pressing and holding the ▲ or ▼ button causes the display to automatically increment.

3. ERV Operation: When in cooling mode AND the conditions are NOT OK for economizing - the ERV terminal will be energized. In the Heating mode, the ERV terminal will be energized when the OA is below the ERV OAT setpoint in the setpoint menu.
4. STATUS → OCCUPIED — The factory-standard Occupancy signal originates with a thermostat or other controller call for indoor fan operation at CTB terminal G. This signal passes through the Central Terminal Board's OCCUPIED jumper JMP1 to the ECONO connector and to the W7220's OCC input terminal. An external timeclock or relay is required to implement an Occupancy schedule on the economizer damper position.
5. STATUS → MA TEMP, SETPOINTS → MAT SET — The W7220 menu parameters and labels include designations MA, MAT and Mixed Air for the economizer cooling control sensor. On these rooftop units, the economizer control sensor is located downstream of the evaporator/indoor coil in the supply fan section where this sensor is designated as Supply Air Temperature (SAT) sensor.
6. SETPOINTS → DRYBLB SET — This point is not displayed if a Return Air (differential) temperature sensor or an Outdoor Air enthalpy sensor is connected.
7. SYSTEM SETUP parameters must be configured as noted for 2-Speed unit operation:  
EQUIPMENT = CONV  
AUX2 IN = W  
FAN SPEED = 2SPEED

For damper minimum position settings and readings on the checkout menus see Table 11. For 1 speed fan dry bulb and enthalpy operation (with and without DCV) see Tables 12-15. For 2 speed fan dry bulb and enthalpy operation (with and without DCV) see Tables 16-19.

**Table 11 — Damper Minimum Position Settings and Readings on Checkout Menu**

DEMAND CONTROLLED VENTILATION (CO2 SENSOR)	FAN SPEED	SETPOINTS	CHECKOUT
NO	1	MIN POS	VMAX-HS
		N/A	N/A
	2	MIN POS H	VMAX-HS
MIN POS L		VMAX-LS	
YES	1	VENT MIN	VMAX-HS
		VENT MAX	VMAX-HS
	2	VENT MIN H	VMAX-HS
		VENT MAX H	VMAX-LS
		VENT MIN L	N/A
		VENT MAX L	N/A

**Table 12 — Dry Bulb Operation No DCV (CO<sub>2</sub> Sensor) — 1 Speed Fan**

DEMAND CONTROLLED VENTILATION (DCV)	OUTSIDE AIR GOOD TO ECONOMIZE	Y1-I	Y2-I	FAN SPEED	Y1-O	Y2-O	OCCUPIED	UNOCCUPIED
NONE	NO	OFF	OFF	HIGH	0v/Off	0v/Off	MIN POS	Closed
		ON	OFF	HIGH	24v/On	0v/Off	MIN POS	Closed
		ON	ON	HIGH	24v/On	24v/On	MIN POS	Closed
NONE	YES	OFF	OFF	HIGH	0v/Off	0v/Off	MIN POS	Closed
		ON	OFF	HIGH	0v/Off	0v/Off	MIN POS to Full Open	Closed to Full-Open
		ON	ON	HIGH	24v/On	0v/Off*	MIN POS to Full Open	Closed to Full-Open

\*With stage 3 delay (STG3 DLY) in Advanced setup menu can turn on second stage of mechanical cooling Y2-O after the delay if the call for Y1-I and Y2-I have not been satisfied.

**Table 13 — Dry Bulb Operation with DCV (CO<sub>2</sub> Sensor) — 1 Speed Fan**

DEMAND CONTROLLED VENTILATION (DCV)	OUTSIDE AIR GOOD TO ECONOMIZE	Y1-I	Y2-I	FAN SPEED	Y1-O	Y2-O	OCCUPIED	UNOCCUPIED
Below CO <sub>2</sub> Set	No	OFF	OFF	HIGH	0v/Off	0v/Off	VENTMIN	Closed
		ON	OFF	HIGH	24v/On	0v/Off	VENTMIN	Closed
		ON	ON	HIGH	24v/On	24v/On	VENTMIN	Closed
	Yes	OFF	OFF	HIGH	0v/Off	0v/Off	VENTMIN	Closed
		ON	OFF	HIGH	0v/Off	0v/Off	VENTMIN to Full-Open	Closed to Full-Open
		ON	ON	HIGH	24v/On	0v/Off	VENTMIN to Full-Open	Closed to Full-Open
Above CO <sub>2</sub> Set	No	OFF	OFF	HIGH	0v/Off	0v/Off	VENTMIN to VENTMAX	Closed
		ON	OFF	HIGH	24v/On	0v/Off	VENTMIN to VENTMAX	Closed
		ON	ON	HIGH	24v/On	24v/On	VENTMIN to VENTMAX	Closed
	Yes	OFF	OFF	HIGH	0v/Off	0v/Off	VENTMIN to VENTMAX	Closed
		ON	OFF	HIGH	0v/Off	0v/Off	VENTMIN to Full-Open	Closed to Full-Open
		ON	ON	HIGH	24v/On	0v/Off*	VENTMIN to Full-Open	Closed to Full-Open

\*With stage 3 delay (STG3 DLY) in Advanced setup menu can turn on second stage of mechanical cooling Y2-O after the delay if the call for Y1-I and Y2-I have not been satisfied.

**Table 14 — Enthalpy Operation No DCV (CO<sub>2</sub> Sensor) — 1 Speed Fan**

DEMAND CONTROLLED VENTILATION (DCV)	OUTSIDE AIR GOOD TO ECONOMIZE	Y1-I	Y2-I	FAN SPEED	Y1-O	Y2-O	OCCUPIED	UNOCCUPIED
NONE	NO	OFF	OFF	HIGH	0v/Off	0v/Off	MIN POS	Closed
		ON	OFF	HIGH	24v/On	0v/Off	MIN POS	Closed
		ON	ON	HIGH	24v/On	24v/On	MIN POS	Closed
NONE	YES	OFF	OFF	HIGH	0v/Off	0v/Off	MIN POS	Closed
		ON	OFF	HIGH	0v/Off	0v/Off	MIN POS to Full Open	Closed to Full-Open
		ON	ON	HIGH	24v/On	0v/Off*	MIN POS to Full Open	Closed to Full-Open

\*With stage 3 delay (STG3 DLY) in Advanced setup menu can turn on second stage of mechanical cooling Y2-O after the delay if the call for Y1-I and Y2-I have not been satisfied.

**Table 15 — Enthalpy Operation with DCV (CO<sub>2</sub> Sensor) — 1 Speed Fan**

DEMAND CONTROLLED VENTILATION (DCV)	OUTSIDE AIR GOOD TO ECONOMIZE	Y1-I	Y2-I	FAN SPEED	Y1-O	Y2-O	OCCUPIED	UNOCCUPIED
Below CO <sub>2</sub> Set	No	OFF	OFF	HIGH	0v/Off	0v/Off	VENTMIN	Closed
		ON	OFF	HIGH	24v/On	0v/Off	VENTMIN	Closed
		ON	ON	HIGH	24v/On	24v/On	VENTMIN	Closed
	Yes	OFF	OFF	HIGH	0v/Off	0v/Off	VENTMIN	Closed
		ON	OFF	HIGH	0v/Off	0v/Off	VENTMIN to Full-Open	Closed to Full-Open
		ON	ON	HIGH	24v/On	0v/Off	VENTMIN to Full-Open	Closed to Full-Open
Above CO <sub>2</sub> Set	No	OFF	OFF	HIGH	0v/Off	0v/Off	VENTMIN to VENTMAX	Closed
		ON	OFF	HIGH	24v/On	0v/Off	VENTMIN to VENTMAX	Closed
		ON	ON	HIGH	24v/On	24v/On	VENTMIN to VENTMAX	Closed
	Yes	OFF	OFF	HIGH	0v/Off	0v/Off	VENTMIN to VENTMAX	Closed
		ON	OFF	HIGH	0v/Off	0v/Off	VENTMIN to Full-Open	Closed to Full-Open
		ON	ON	HIGH	24v/On	0v/Off*	VENTMIN to Full-Open	Closed to Full-Open

\*With stage 3 delay (STG3 DLY) in Advanced setup menu can turn on second stage of mechanical cooling Y2-O after the delay if the call for Y1-I and Y2-I have not been satisfied.

**Table 16 — Dry Bulb Operation No DCV (CO<sub>2</sub> Sensor) — 2 Speed Fan**

DEMAND CONTROLLED VENTILATION (DCV)	OUTSIDE AIR GOOD TO ECONOMIZE	Y1-I	Y2-I	FAN SPEED	Y1-O	Y2-O	OCCUPIED	UNOCCUPIED
NONE	NO	OFF	OFF	LOW	0v/Off	0v/Off	MIN POS	Closed
		ON	OFF	LOW	24v/On	0v/Off	MIN POS	Closed
		ON	ON	HIGH	24v/On	24v/On	MIN POS	Closed
NONE	YES	OFF	OFF	LOW	0v/Off	0v/Off	MIN POS	Closed
		ON	OFF	LOW	0v/Off	0v/Off	MIN POS to Full Open	Closed to Full-Open
		ON	ON	HIGH	24v/On	0v/Off*	MIN POS to Full Open	Closed to Full-Open

\*With stage 3 delay (STG3 DLY) in Advanced setup menu can turn on second stage of mechanical cooling Y2-O after the delay if the call for Y1-I and Y2-I have not been satisfied.

**Table 17 — Dry Bulb Operation with DCV (CO<sub>2</sub> Sensor) — 2 Speed Fan**

DEMAND CONTROLLED VENTILATION (DCV)	OUTSIDE AIR GOOD TO ECONOMIZE	Y1-I	Y2-I	FAN SPEED	Y1-O	Y2-O	OCCUPIED	UNOCCUPIED
Below CO <sub>2</sub> Set	No	OFF	OFF	LOW	0v/Off	0v/Off	VENTMIN	Closed
		ON	OFF	LOW	24v/On	0v/Off	VENTMIN	Closed
		ON	ON	HIGH	24v/On	24v/On	VENTMIN	Closed
	Yes	OFF	OFF	LOW	0v/Off	0v/Off	VENTMIN	Closed
		ON	OFF	LOW	0v/Off	0v/Off	VENTMIN to Full-Open	Closed to Full-Open
		ON	ON	HIGH	24v/On	0v/Off	VENTMIN to Full-Open	Closed to Full-Open
Above CO <sub>2</sub> Set	No	OFF	OFF	LOW	0v/Off	0v/Off	VENTMIN to VENTMAX	Closed
		ON	OFF	LOW	24v/On	0v/Off	VENTMIN to VENTMAX	Closed
		ON	ON	HIGH	24v/On	24v/On	VENTMIN to VENTMAX	Closed
	Yes	OFF	OFF	LOW	0v/Off	0v/Off	VENTMIN to VENTMAX	Closed
		ON	OFF	LOW	0v/Off	0v/Off	VENTMIN to Full-Open	Closed to Full-Open
		ON	ON	HIGH	24v/On	0v/Off*	VENTMIN to Full-Open	Closed to Full-Open

\*With stage 3 delay (STG3 DLY) in Advanced setup menu can turn on second stage of mechanical cooling Y2-O after the delay if the call for Y1-I and Y2-I have not been satisfied.

**Table 18 — Enthalpy Operation No DCV (CO<sub>2</sub> Sensor) — 2 Speed Fan**

DEMAND CONTROLLED VENTILATION (DCV)	OUTSIDE AIR GOOD TO ECONOMIZE	Y1-I	Y2-I	FAN SPEED	Y1-O	Y2-O	OCCUPIED	UNOCCUPIED
NO CO <sub>2</sub> SENSOR	NO	OFF	OFF	LOW	0v/Off	0v/Off	MIN POS	Closed
		ON	OFF	LOW	24v/On	0v/Off	MIN POS	Closed
		ON	ON	HIGH	24v/On	24v/On	MIN POS	Closed
	YES	OFF	OFF	LOW	0v/Off	0v/Off	MIN POS	Closed
		ON	OFF	LOW	0v/Off	0v/Off	MIN POS to Full Open	Closed to Full-Open
		ON	ON	HIGH	24v/On	0v/Off*	MIN POS to Full Open	Closed to Full-Open

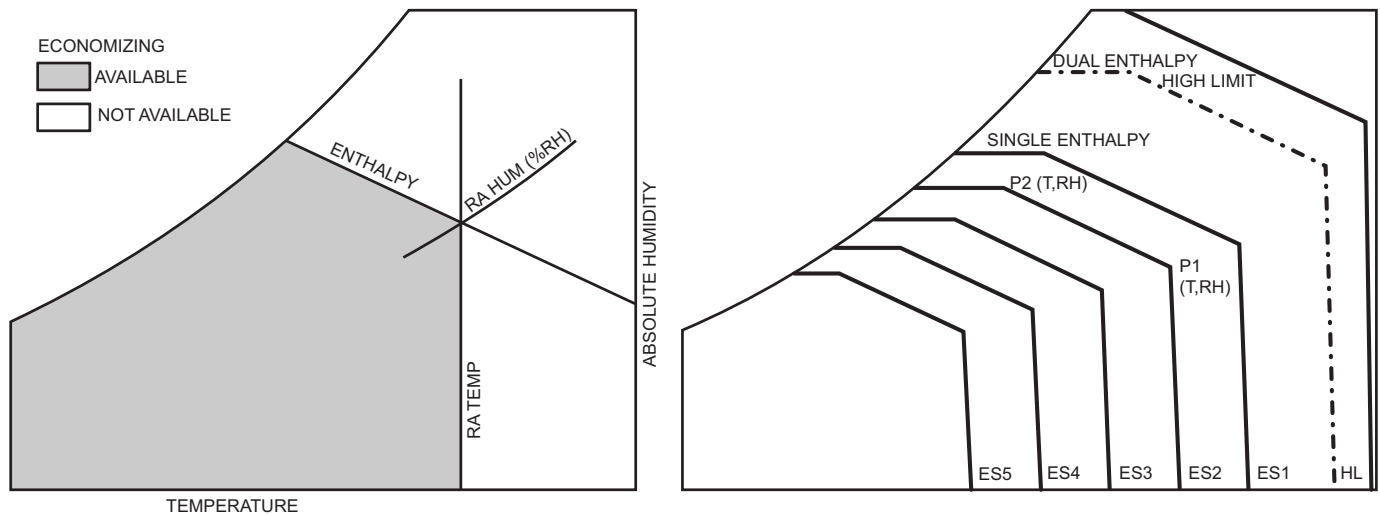
\*With stage 3 delay (STG3 DLY) in Advanced setup menu can turn on second stage of mechanical cooling Y2-O after the delay if the call for Y1-I and Y2-I have not been satisfied.

**Table 19 — Enthalpy Operation with DCV (CO<sub>2</sub> Sensor) — 2 Speed Fan**

DEMAND CONTROLLED VENTILATION (DCV)	OUTSIDE AIR GOOD TO ECONOMIZE	Y1-I	Y2-I	FAN SPEED	Y1-O	Y2-O	OCCUPIED	UNOCCUPIED
Below CO <sub>2</sub> Set	No	OFF	OFF	LOW	0v/Off	0v/Off	VENTMIN	Closed
		ON	OFF	LOW	24v/On	0v/Off	VENTMIN	Closed
		ON	ON	HIGH	24v/On	24v/On	VENTMIN	Closed
	Yes	OFF	OFF	LOW	0v/Off	0v/Off	VENTMIN	Closed
		ON	OFF	LOW	0v/Off	0v/Off	VENTMIN to Full-Open	Closed to Full-Open
		ON	ON	HIGH	24v/On	0v/Off	VENTMIN to Full-Open	Closed to Full-Open
Above CO <sub>2</sub> Set	No	OFF	OFF	LOW	0v/Off	0v/Off	VENTMIN to VENTMAX	Closed
		ON	OFF	LOW	24v/On	0v/Off	VENTMIN to VENTMAX	Closed
		ON	ON	HIGH	24v/On	24v/On	VENTMIN to VENTMAX	Closed
	Yes	OFF	OFF	LOW	0v/Off	0v/Off	VENTMIN to VENTMAX	Closed
		ON	OFF	LOW	0v/Off	0v/Off	VENTMIN to Full-Open	Closed to Full-Open
		ON	ON	HIGH	24v/On	0v/Off*	VENTMIN to Full-Open	Closed to Full-Open

\*With stage 3 delay (STG3 DLY) in Advanced setup menu can turn on second stage of mechanical cooling Y2-O after the delay if the call for Y1-I and Y2-I have not been satisfied.





**Fig. 43 — Single Enthalpy Curve Boundaries**

**Table 20 — Single Enthalpy and Dual Enthalpy High Limit Curves**

ENTHALPY CURVE	TEMP. DRY BULB (F)	TEMP. DEWPOINT (F)	ENTHALPY (btu/lb/da)	POINT P1		POINT P2	
				TEMP. (F)	HUMIDITY (%RH)	TEMP. (F)	HUMIDITY (%RH)
ES1	80	60	28.0	80	36.8	66.3	80.1
ES2	75	57	26.0	75	39.6	63.3	80.0
ES3	70	54	24.0	70	42.3	59.7	81.4
ES4	65	51	22.0	65	44.8	55.7	84.2
ES5	60	48	20.0	60	46.9	51.3	88.5
HL	86	66	32.4	86	38.9	72.4	80.3

**ENTHALPY SETTINGS** — When the OA temperature, enthalpy and dew point are below the respective setpoints, the Outdoor Air can be used for economizing. Figure 43 shows the new single enthalpy boundaries in the W7220. There are 5 boundaries (setpoints ES1 through ES5), which are defined by dry bulb temperature, enthalpy and dew point.

Refer to Table 20 for ENTH CURVE setpoint values.

The W7220 calculates the enthalpy and dew point using the OA temperature and humidity input from the OA enthalpy sensor. When the OA temperature, OA humidity and OA dew point are all below the selected boundary, the economizer sets the economizing mode to YES, economizing is available.

When all of the OA conditions are above the selected boundary, the conditions are not good to economize and the mode is set to NO.

Figure 43 shows the 5 current boundaries. There is also a high limit boundary for differential enthalpy. The high limit boundary is ES1 when there are no stages of mechanical cooling energized and HL (high limit) when a compressor stage is energized.

Table 20 provides the values for each boundary limit.

**TWO-SPEED FAN OPERATION** — The W7220 controller has the capability to work with a system using a 2-speed supply fan. The W7220 does not control the supply directly but uses the following input status to determine the speed of the supply fan and controls the OA damper to the required position, see Table 21.

**Table 21 — Fan Speed**

STATE	FAN SPEED
OCC	Low
Y1	Low
Y2	High
W	High

The W (heating mode) is not controlled by the W7220 but it requires the status to know where to position the OA damper for minimum position for the fan speed.

The 2 speed fan delay is available when the system is programmed for 2 speed fan (in the System Setup menu item). The 2 speed fan delay is defaulted to 5 minutes and can be changed in the Advanced Setup menu item. When the unit has a call for Y1 In and in the free cooling mode and there is a call for Y2 In, the 2-speed fan delay starts and the OA damper will modulate 100% open, the supply fan should be set to high speed by the unit controller.

After the delay one of two actions will happen:

- The Y2 In call will be satisfied with the damper 100% open and fan on high speed and the call will turn off OR
- If the call for additional cooling in the space has not been satisfied then the first stage of mechanical cooling will be enabled through Y1 Out or Y2 Out.

**CHECKOUT** — Inspect all wiring connections at the economizer module's terminals, and verify compliance with the installation wiring diagrams.

For checkout, review the Status of each configured parameter and perform the Checkout tests.

NOTE: See "Interface Overview" on page 28 for information about menu navigation and use of the keypad.

**⚠ WARNING**

Failure to follow this warning could result in personal injury, property damage, or death.

Before performing service or maintenance operations on unit, always turn off main power switch to unit and install lock(s) and lockout tag(s). Unit may have more than one power switch. Ensure electrical service to rooftop unit agrees with voltage and amperage listed on the unit rating plate.

If any wiring changes are required, first be sure to remove power from the economizer module before starting work. Pay particular attention to verifying the power connection (24 Vac).

**Power Up** — After the W7220 module is mounted and wired, apply power.

**Initial Menu Display** — On initial start up, Honeywell displays on the first line and Economizer W7220 on the second line. After a brief pause, the revision of the software appears on the first line and the second line will be blank.

**Power Loss (Outage or Brownout)** — All setpoints and advanced settings are restored after any power loss or interruption.

NOTE: All settings are stored in non-volatile flash memory.

**Status** — Use the Status menu (see Table 10) to check the parameter values for the various devices and sensors configured.

NOTE: See "Interface Overview" on page 28 for information about menu navigation and use of the keypad.

**Checkout Tests** — Use the Checkout menu (in Table 10) to test the damper operation and any configured outputs. Only items that are configured are shown in the Checkout menu.

NOTE: See "Interface Overview" on page 28 for information about menu navigation and use of the keypad.

To perform a Checkout test:

1. Scroll to the desired test in the Checkout menu using the ▲ and ▼ buttons.
2. Press the ← button to select the item.
3. RUN? appears.
4. Press the ← button to start the test.
5. The unit pauses and then displays IN PROGRESS.
6. When the test is complete, DONE appears.
7. When all desired parameters have been tested, press the ⬆ (Menu Up) button to end the test.

The Checkout tests can all be performed at the time of installation or at any time during the operation of the system as a test that the system is operable.

**TROUBLESHOOTING**

**Alarms** — The economizer module provides alarm messages that display on the 2-line LCD.

NOTE: Upon power up, the module waits 60 minutes before checking for alarms. This allows time for all the configured devices (e.g. sensors, actuator) to become operational. The exception is the SAT sensor which will alarm immediately.

If one or more alarms are present and there has been no keypad activity for at least 5 minutes, the Alarms menu displays and cycles through the active alarms.

You can also navigate to the Alarms menu at any time.

**Clearing Alarms** — Once the alarm has been identified and the cause has been removed (e.g. replaced faulty sensor) the alarm can be cleared from the display.

To clear an alarm, perform the following:

1. Navigate to the desired alarm.
2. Press the ← button.
3. ERASE? displays.
4. Press the ← button.
5. ALARM ERASED displays.
6. Press the ⬆ (Menu up/Exit) button to complete the action and return to the previous menu.

NOTE: If the alarm still exists after you clear it, it is redisplayed within 5 seconds.

**⚠ CAUTION**

Failure to follow this caution may result in damage to equipment. Be sure to allow enough time for compressor startup and shutdown between checkout tests so that you do not short-cycle the compressors.

**PremierLink™ Controller (Factory-Option) —**

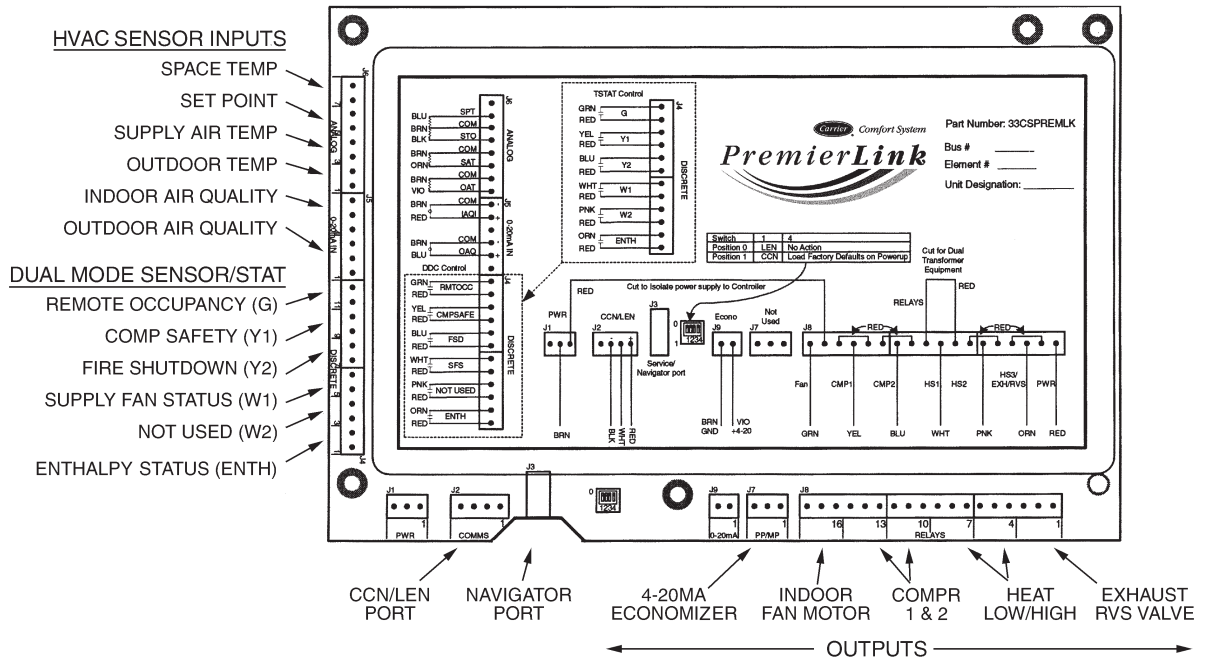
The PremierLink controller (see Fig. 44) is compatible with Carrier Comfort Network® (CCN) devices. This control is designed to allow users the access and ability to change factory-defined settings, thus expanding the function of the standard unit control board. CCN service access tools include System Pilot™, Touch Pilot™ and Service Tool. (Standard tier display tools Navigator and Scrolling Marquee are not suitable for use with latest PremierLink controller (Version 2.x).)

The PremierLink control is factory-mounted in the 48TC unit's main control box to the right of the Central Terminal Board (CTB) (see Fig. 45). Factory wiring is completed through harnesses connected to the CTB thermostat. Field connections are made at a 16-pole terminal block (TB3) located at the top of the unit control box in front of the PremierLink controller. The factory-installed PremierLink control includes the supply-air temperature (SAT) sensor. The outdoor air temperature (OAT) sensor is included in the FIOP/accessory EconoMiSer® 2 package.

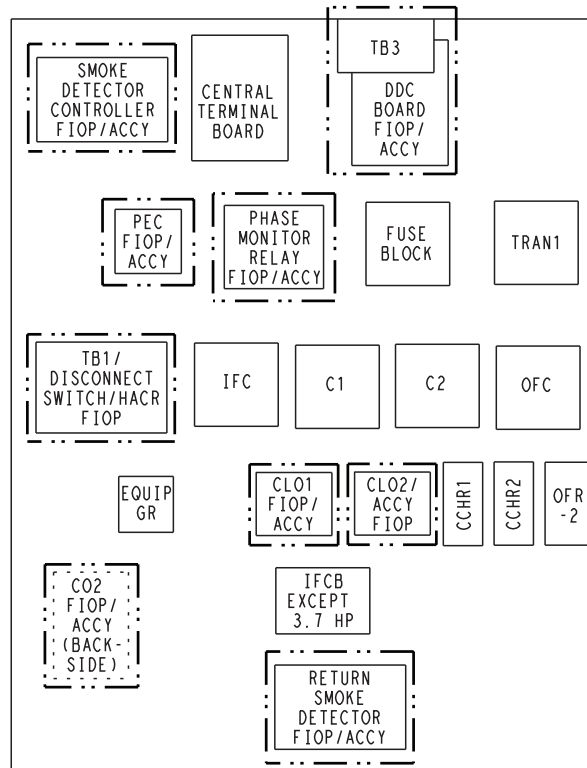
The PremierLink controller requires the use of a Carrier electronic thermostat or a CCN connection for time broadcast to initiate its internal time-clock. This is necessary for broadcast of time of day functions (occupied/unoccupied).

NOTE: PremierLink controller is shipped in Sensor mode. To be used with a thermostat, the PremierLink controller must be configured to Thermostat mode. Refer to PremierLink Configuration instructions for Operating Mode.

For wiring the PremierLink controller see Fig. 46. For wiring the controller to a unit equipped with a Humidi-MiZer® system see Fig. 47.



**Fig. 44 — PremierLink Controller**



**Fig. 45 — 48TC Control Box Component Locations**

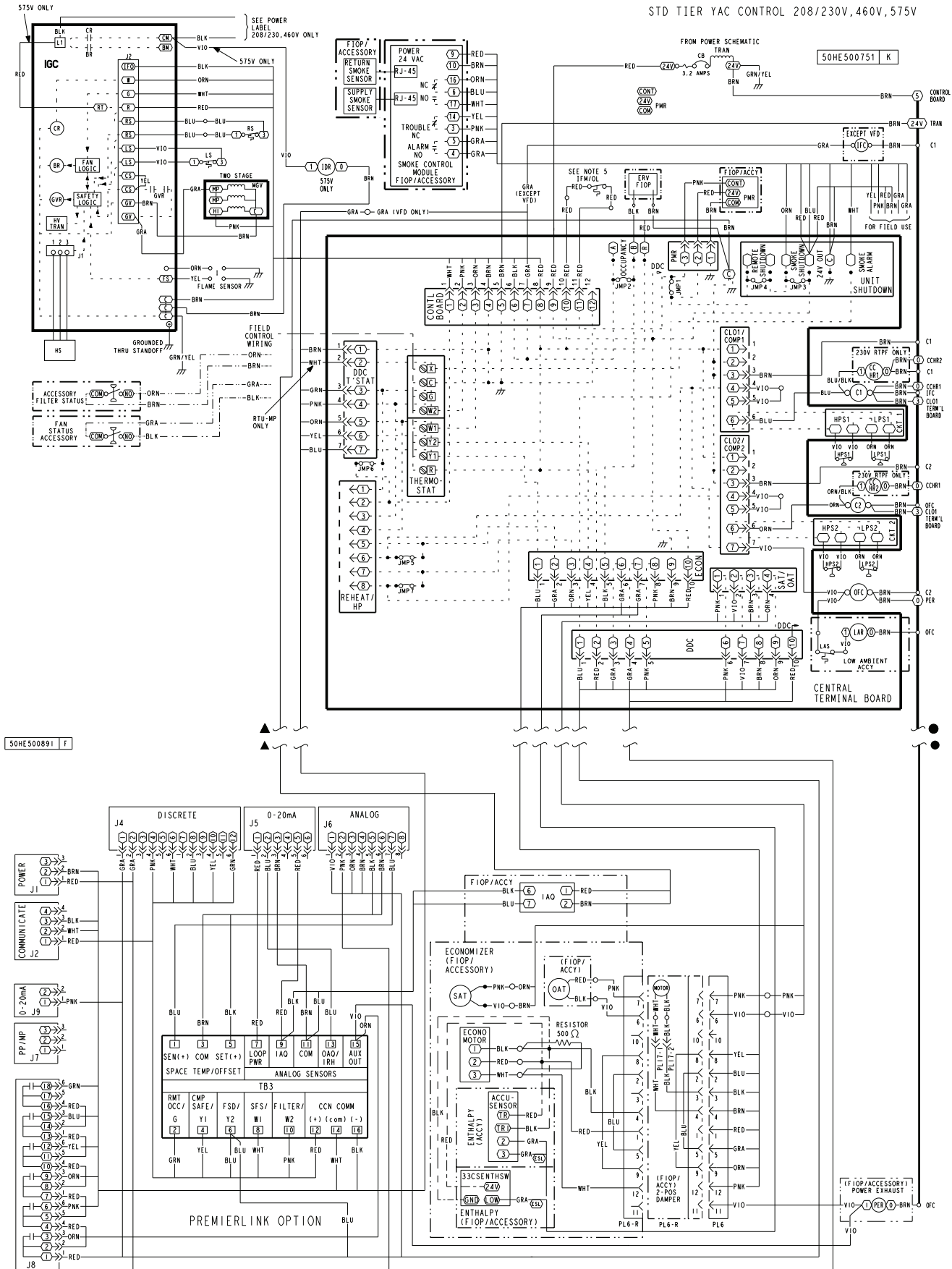


Fig. 46 — PremierLink™ Wiring Diagram

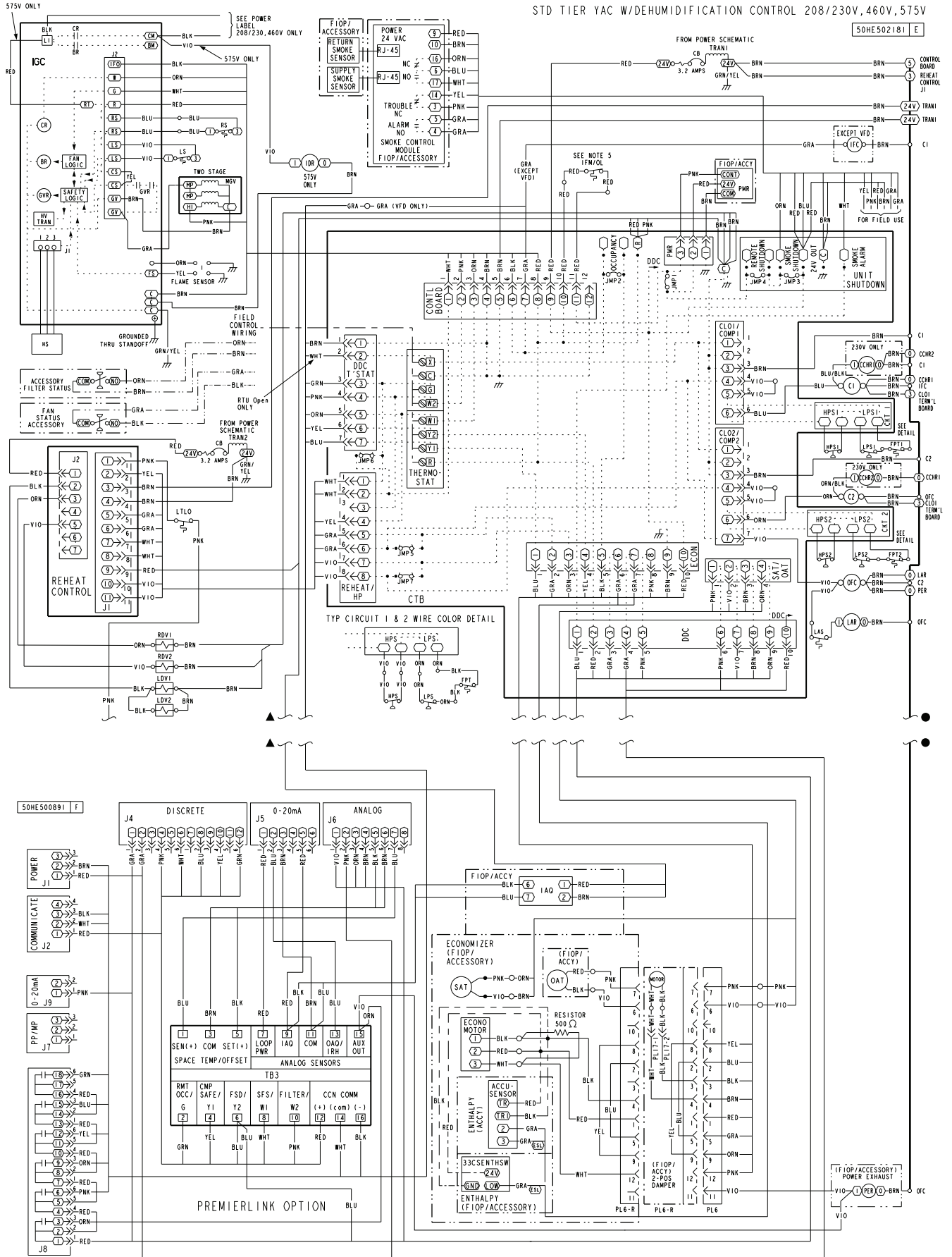
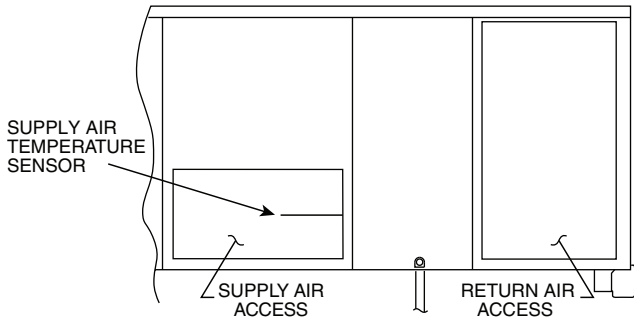


Fig. 47 — PremierLink Wiring Diagram with Humidi-MiZer® System



**SUPPLY AIR TEMPERATURE (SAT) SENSOR** — On FIOP-equipped 48TC unit, the unit is supplied with a supply-air temperature (SAT) sensor (33ZCSENSAT). This sensor is a tubular probe type, approx 6-inches (152 mm) in length. It is a nominal 10-k ohm thermistor.

The SAT is factory-wired. The SAT probe is mounted in the fan deck (see Fig. 48). It can be removed or remounted per local codes. Drill or punch a 1/2-in. hole in the flange or duct. Use two field-supplied, self-drilling screws to secure the sensor probe in a horizontal orientation. Ensure that the sensor wires do not contact the hot surface of the heat exchanger.



**Fig. 48 — Typical Mounting Location for Supply Air Temperature (SAT) Sensor on 48TC Units**

NOTE: Refer to PremierLink™ Retrofit Rooftop Controller Installation, Start-Up and Configuration Instructions for complete PremierLink configuration, operating sequences and troubleshooting information. Have a copy of this manual available at unit start-up.

NOTE: The sensor must be mounted in the discharge air-stream downstream of the cooling coil and any heating devices. Be sure the probe tip does not come in contact with any of the unit's heater surfaces.

**OUTDOOR AIR TEMPERATURE (OAT) SENSOR** — The OAT is factory-mounted in the EconoMiSer®2 (FIOP or accessory). It is a nominal 10k ohm thermistor attached to an eyelet mounting ring.

**ECONOMISER® 2** — The PremierLink control is used with EconoMiSer2 (option or accessory) for outdoor air management. The damper position is controlled directly by the PremierLink control; EconoMiSer2 has no internal logic device.

Outdoor air management functions can be enhanced with field-installation of these accessory control devices:

- Enthalpy control (outdoor air or differential sensors)
- Space CO<sub>2</sub> sensor
- Outdoor air CO<sub>2</sub> sensor

Refer to Table 22 for accessory part numbers.

**Field Connections** — Field connections for accessory sensor and input devices are made at the 16-pole terminal block (TB3, see Fig. 46 and 47) located on the control box top shelf in front of the PremierLink control. Some input devices also require a 24-vac signal source; connect at CTB terminal R at "THERMOSTAT" connection strip for this signal source. See connections figures on following pages for field connection locations (and for continued connections at the PremierLink board inputs).

Table 22 provides a summary of field connections for units equipped with Space Sensor. Tables 23 and 24 provides a summary of field connections for units equipped with Space Thermostat.

**Table 22 — PremierLink™ Sensor Usage**

APPLICATION	OUTDOOR AIR TEMPERATURE SENSOR	RETURN AIR TEMPERATURE SENSOR	OUTDOOR AIR ENTHALPY SENSOR	RETURN AIR ENTHALPY SENSOR
Differential Dry Bulb Temperature with PremierLink (PremierLink requires 4-20 mA Actuator)	Included — CRTEMPN001A00	Required — 33ZCT55SPT or equivalent	—	—
Single Enthalpy with PremierLink (PremierLink requires 4-20 mA Actuator)	Included — Not Used	—	Requires — 33CSENTHSW	—
Differential Enthalpy with PremierLink (PremierLink requires 4-20 mA Actuator)	Included — Not Used	—	Requires — 33CSENTHSW or equivalent	Requires — 33CSENTSEN or equivalent

NOTE: CO<sub>2</sub> Sensors (Optional):

33ZCSENSCO2 — Room sensor (adjustable). Aspirator box is required for duct mounting of the sensor.

33ZCASPCO2 — Aspirator box used for duct-mounted CO<sub>2</sub> room sensor.

33ZCT55CO2 — Space temperature and CO<sub>2</sub> room sensor with override.

33ZCT56CO2 — Space temperature and CO<sub>2</sub> room sensor with override and setpoint.

**Table 23 — Space Sensor Mode**

TB3 TERMINAL	FIELD CONNECTION	INPUT SIGNAL
1	T55-SEN/T56-SEN	Analog (10k thermistor)
2	RMT OCC	Discrete, 24VAC
3	T55-SEN/T56-SEN	Analog (10k thermistor)
4	CMPSAFE	Discrete, 24VAC
5	T56-SET	Analog (10k thermistor)
6	FSD	Discrete, 24VAC
7	LOOP-PWR	Analog, 24VDC
8	SPS	Discrete, 24VAC
9	IAQ-SEN	Analog, 4-20mA
10	FILTER	Discrete, 24VAC
11	IAQ-COM/OAQ-COM/RH-COM	Analog, 4-20mA
12	CCN + (RED)	Digital, 5VDC
13	OAQ-SEN/RH-SEN	Analog, 4-20mA
14	CCN Gnd (WHT)	Digital, 5VDC
15	AUX OUT (Power Exhaust)	(Output) Discrete 24VAC
16	CCN - (BLK)	Digital, 5VDC

**LEGEND**

- T55** — Space Temperature Sensor
- T56** — Space Temperature Sensor
- CCN** — Carrier Comfort Network® (communication bus)
- CMPSAFE** — Compressor Safety
- FILTER** — Dirty Filter Switch
- FSD** — Fire Shutdown
- IAQ** — Indoor Air Quality (CO<sub>2</sub>)
- OAQ** — Outdoor Air Quality (CO<sub>2</sub>)
- RH** — Relative Humidity
- SFS** — Supply Fan Status

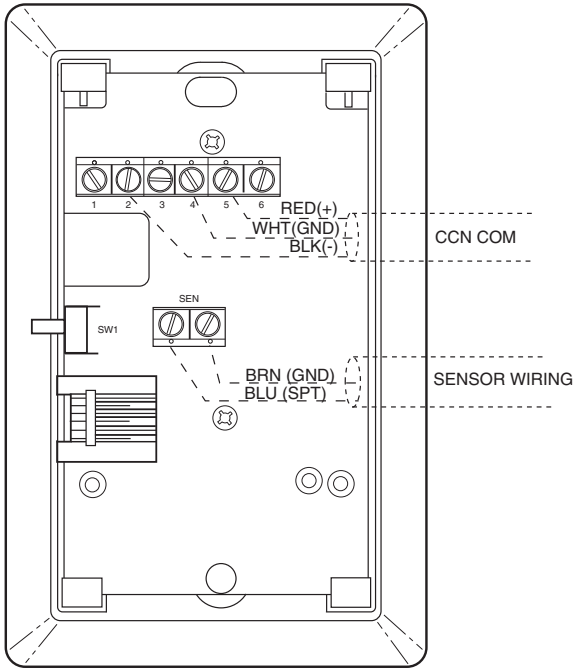
**Table 24 — Thermostat Mode**

TB3 TERMINAL	FIELD CONNECTION	INPUT SIGNAL
1	RAT SEN	Analog (10k thermistor)
2	G	Discrete, 24VAC
3	RAT SEN	Analog (10k thermistor)
4	Y1	Discrete, 24VAC
5		
6	Y2	Discrete, 24VAC
7	LOOP-PWR	Analog, 24VDC
8	W1	Discrete, 24VAC
9	IAQ-SEN	Analog, 4-20mA
10	W2	Discrete, 24VAC
11	IAQ-COM/OAQ-COM/RH-COM	Analog, 4-20mA
12	CCN + (RED)	Digital, 5VDC
13	OAQ-SEN/RH-SEN	Analog, 4-20mA
14	CCN Gnd (WHT)	Digital, 5VDC
15	AUX OUT (Power Exhaust)	(Output) Discrete 24VAC
16	CCN - (BLK)	Digital, 5VDC

**LEGEND**

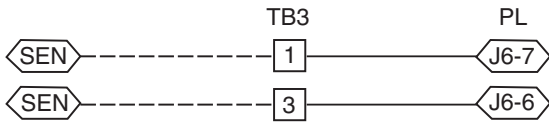
- CCN** — Carrier Comfort Network (communication bus)
- G** — Thermostat Fan
- IAQ** — Indoor Air Quality (CO<sub>2</sub>)
- OAQ** — Outdoor Air Quality (CO<sub>2</sub>)
- RAT** — Return Air Temperature
- RH** — Relative Humidity
- W1** — Thermostat Heat Stage 1
- W2** — Thermostat Heat Stage 2
- Y1** — Thermostat Cool Stage 1
- Y2** — Thermostat Cool Stage 2

**SPACE SENSORS** — The PremierLink™ controller is factory-shipped configured for Space Sensor Mode. A Carrier T-55 or T-56 space sensor must be used. T-55 space temperature sensor provides a signal of space temperature to the PremierLink control, see Fig. 49. T-56 provides same space temperature signal plus it allows for adjustment of space temperature setpoints from the face of the sensor by the occupants.



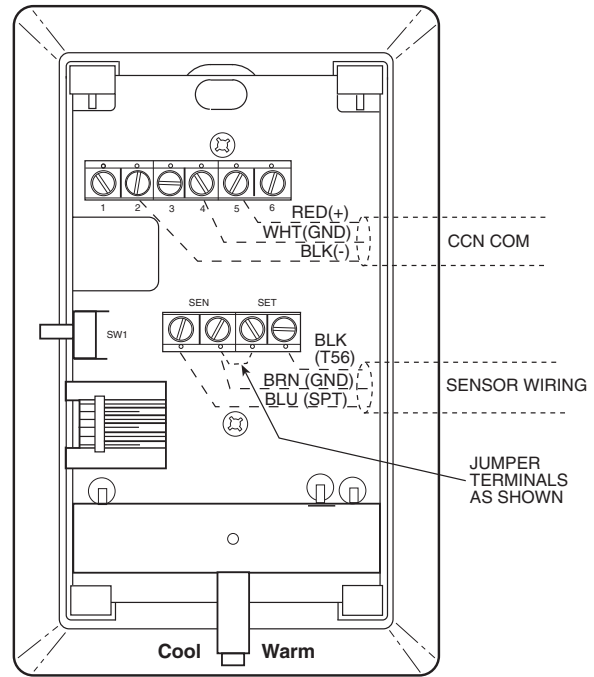
**Fig. 49 — T-55 Space Temperature Sensor Wiring**

**Connect T-55** — See Fig. 49 for typical T-55 internal connections. Connect the T-55 SEN terminals to TB3 terminals 1 and 3 (see Fig. 50).

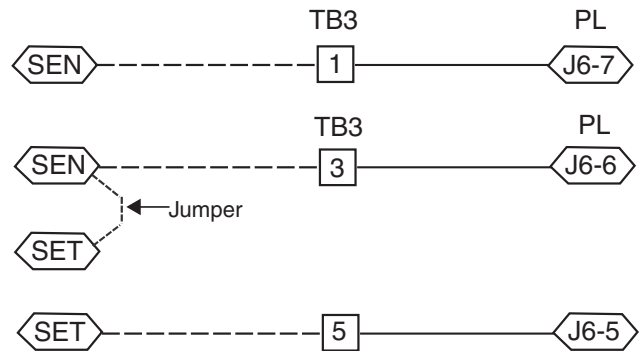


**Fig. 50 — PremierLink T-55 Sensor**

**Connect T-56** — See Fig. 51 for T-56 internal connections. Install a jumper between SEN and SET terminals as illustrated. Connect T-56 terminals to TB3 terminals 1, 3, and 5 (see Fig. 52).



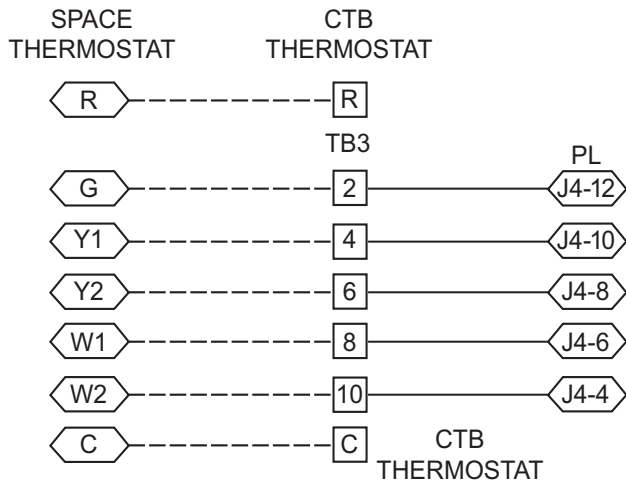
**Fig. 51 — T-56 Internal Connections**



**Fig. 52 — PremierLink T-56 Sensor**

**CONNECT THERMOSTAT** — A 7-wire thermostat connection requires a 24-v power source and a common connection. Use the R and C terminals on the CTB's THERMOSTAT connection strip for these. Connect the thermostat's Y1, Y2, W1, W2 and G terminals to PremierLink TB3 as shown in Fig. 53.

If the 48TC unit is equipped with factory-installed smoke detector(s), disconnect the factory BLU lead at TB3-6 (Y2) before connecting the thermostat. Identify the BLU lead originating at CTB-DDC-1; disconnect at TB3-6 and tape off. Confirm that the second BLU lead at TB3-6 remains connected to PremierLink J4-8.



**Fig. 53 — Space Thermostat Connections**

If the 48TC unit has an economizer system and free-cooling operation is required, a sensor representing Return Air Temperature must also be connected (field-supplied and installed). This sensor may be a T-55 Space Sensor (see Fig. 49) installed in the space or in the return duct, or it may be sensor P/N 33ZCSENSAT, installed in the return duct. Connect this sensor to TB3-1 and TB3-3 per Fig. 50.

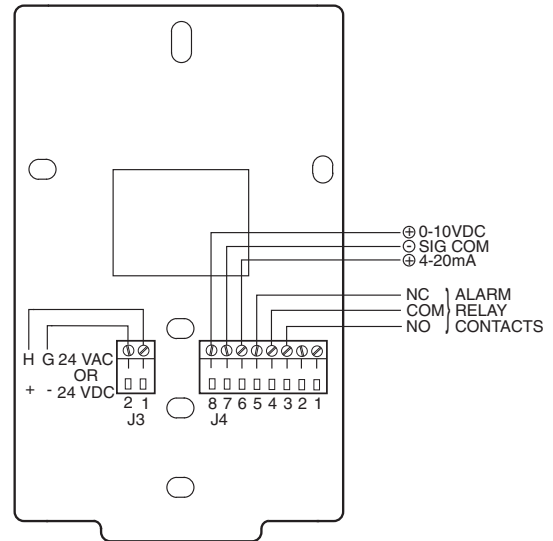
**Configure the Unit for Thermostat Mode** — Connect to the CCN bus using a CCN service tool and navigate to PremierLink Configuration screen for Operating Mode. Default setting is Sensor Mode (value 1). Change the value to 0 to reconfigure the controller for Thermostat Mode.

When the PremierLink controller is configured for Thermostat Mode, these functions are not available: Fire Shutdown (FSD), Remote Occupied (RMTOCC), Compressor Safety (CMPSAFE), Supply Fan Status (SFS), and Filter Pressure Switch (FILTER).

### Economizer Controls

**INDOOR AIR QUALITY (CO<sub>2</sub>) SENSOR** — The indoor air quality sensor accessory monitors space carbon dioxide (CO<sub>2</sub>) levels. This information is used to monitor IAQ levels. Several types of sensors are available, for wall mounting in the space or in return duct, with and without LCD display, and in combination with space temperature sensors. Sensors use infrared technology to measure the levels of CO<sub>2</sub> present in the space air.

The CO<sub>2</sub> sensors are all factory set for a range of 0 to 2000 ppm and a linear mA output of 4 to 20. Refer to the instructions supplied with the CO<sub>2</sub> sensor for electrical requirements and terminal locations. See Fig. 54 for typical CO<sub>2</sub> sensor wiring schematic.



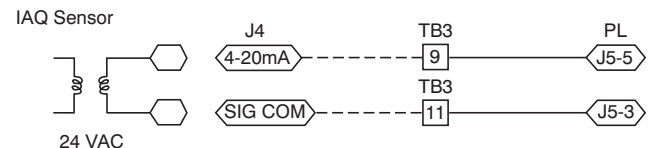
**Fig. 54 — Indoor/Outdoor Air Quality (CO<sub>2</sub>) Sensor (33ZCSENSCO2) — Typical Wiring Diagram**

To accurately monitor the quality of the air in the conditioned air space, locate the sensor near a return-air grille (if present) so it senses the concentration of CO<sub>2</sub> leaving the space. The sensor should be mounted in a location to avoid direct breath contact.

Do not mount the IAQ sensor in drafty areas such as near supply ducts, open windows, fans, or over heat sources. Allow at least 3 ft (0.9 m) between the sensor and any corner. Avoid mounting the sensor where it is influenced by the supply air; the sensor gives inaccurate readings if the supply air is blown directly onto the sensor or if the supply air does not have a chance to mix with the room air before it is drawn into the return airstream.

**Wiring the Indoor Air Quality Sensor** — For each sensor, use two 2-conductor 18 AWG (American Wire Gauge) twisted-pair cables (unshielded) to connect the separate isolated 24 vac power source to the sensor and to connect the sensor to the control board terminals.

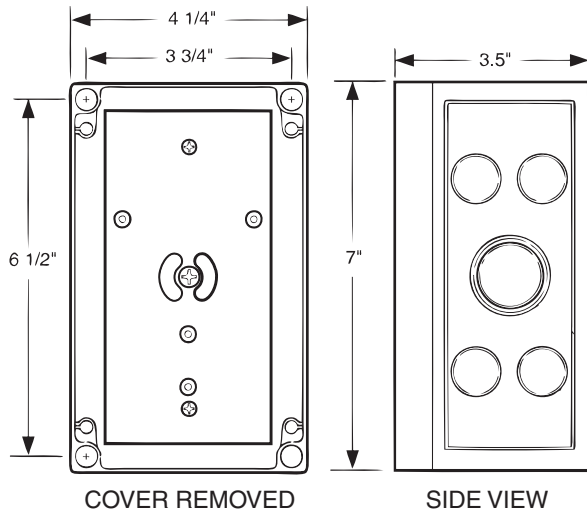
To connect the sensor to the control, identify the positive (4 to 20 mA) and ground (SIG COM) terminals on the sensor. See Fig. 54. Connect the 4-20 mA terminal to terminal TB3-9 and connect the SIG COM terminal to terminal TB3-11. See Fig. 55.



**Fig. 55 — Indoor CO<sub>2</sub> Sensor (33ZCSENSCO2) Connections**

Refer to PremierLink Installation, Start-up, and Configuration Instructions, for detailed configuration information.

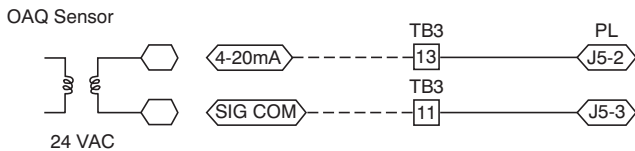
**OUTDOOR AIR QUALITY SENSOR (P/N: 33ZCSENSCO2 PLUS WEATHERPROOF ENCLOSURE)** — The outdoor air CO<sub>2</sub> sensor is designed to monitor carbon dioxide (CO<sub>2</sub>) levels in the outside ventilation air and interface with the ventilation damper in an HVAC system. The OAQ sensor is packaged with an outdoor cover. See Fig. 56. The outdoor air CO<sub>2</sub> sensor must be located in the economizer outside air hood.



**Fig. 56 — Outdoor Air Quality Sensor Cover**

**Wiring the Outdoor Air CO<sub>2</sub> Sensor** — A dedicated power supply is required for this sensor. A two-wire cable is required to wire the dedicated power supply for the sensor. The two wires should be connected to the power supply and terminals 1 and 2.

To connect the sensor to the control, identify the positive (4 to 20 mA) and ground (SIG COM) terminals on the OAQ sensor. See Fig. 54. Connect the 4 to 20 mA terminal to the TB3-13 terminal of the 48TC unit. Connect the SIG COM terminal to the TB3-11 terminal of the 48TC unit. See Fig. 57.



**Fig. 57 — Outdoor CO<sub>2</sub> Sensor Connections**

**SPACE RELATIVE HUMIDITY SENSOR OR HUMIDISTAT CONNECTIONS**

**Space Relative Humidity Sensor Connections** — The accessory space relative humidity sensor (33ZCSENSRH-01) is installed on an interior wall to measure the relative humidity of the air within the occupied space.

The use of a standard 2 X 4 inch electrical box to accommodate the wiring is recommended for installation. The sensor can be mounted directly on the wall, if acceptable by local codes.

**CAUTION**

Failure to follow this caution may result in permanent damage to the sensor.

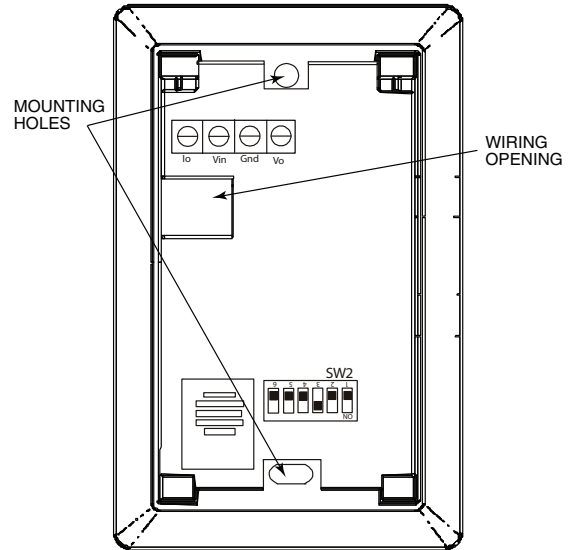
DO NOT clean or touch the sensing element with chemical solvents as they can permanently damage the sensor.

**CAUTION**

Failure to follow this caution will result in inaccurate sensor readings.

DO NOT mount the sensor in drafty areas such as near heating or air-conditioning ducts, open windows, fans, or over heat sources such as baseboard heaters, radiators, or wall-mounted dimmers. Sensors mounted in those areas will produce inaccurate readings.

If the sensor is installed directly on a wall service, install the humidity sensor using 2 screws and 2 hollow wall anchors (field-supplied). Do not over tighten screws. See Fig. 58.

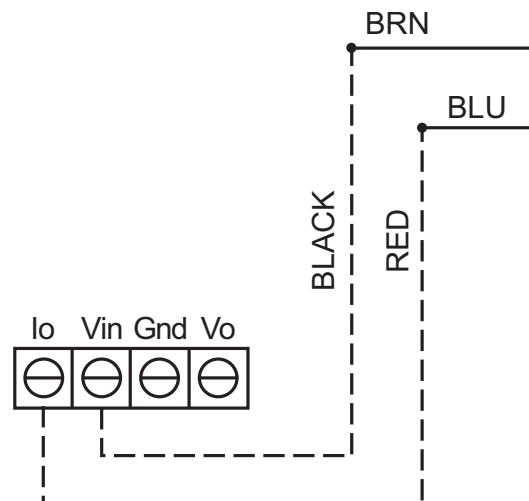


**Fig. 58 — Space Relative Humidity Sensor Installation**

The sensor must be mounted vertically on the wall. The Carrier logo should be orientated correctly when the sensor is properly mounted.

Avoid corner locations. Allow at least 4 ft between the sensor and any corner. Airflow near corners tends to be reduced, resulting in erratic sensor readings. The sensor should be vertically mounted approximately 5 ft up from the floor, beside the space temperature sensor.

For wiring distances up to 500 feet, use a 3-conductor, 18 or 20 AWG cable. A CCN communication cable can be used, although the shield is not required. The shield must be removed from the sensor end of the cable if this cable is used. See Fig. 59 for wiring details.



**Fig. 59 — Space Relative Humidity Sensor Connection**

The power for the sensor is provided by the PremierLink control on terminal J5-4 (+33 to +35vdc).

To wire the sensor:

1. At the sensor, remove 4 inches of the jacket from the cable. Strip 1/4 inch of insulation from each conductor.

Route the cable through the wire clearance opening in the center of the sensor. See Fig. 58.

2. Connect a field-supplied BLACK wire to the sensor screw terminal marked Vin.
3. Connect a field-supplied RED wire into the sensor screw terminal marked Io.
4. Connect the field-supplied RED wire from the sensor to TB3-13.
5. Connect the field-supplied BLACK wire from the sensor to TB3-7.

**Humidistat Connections** — A humidistat can not be directly connected to the PremierLink controller. Follow the instructions on pages 24 and 25 to connect a humidistat or a thermostat as an electromechanical device.

**SMOKE DETECTOR/FIRE SHUTDOWN (FSD)** — This function is available only when PremierLink is configured for (Space) Sensor Mode. The unit is factory-wired for PremierLink FSD operation when PremierLink is factory-installed.

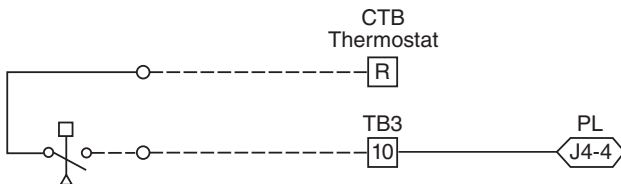
On 48TC units equipped with factory-installed Smoke Detector(s), the smoke detector controller implements the unit shutdown through its NC contact set connected to the unit's CTB input. The FSD function is initiated via the smoke detector's Alarm NO contact set. The PremierLink communicates the smoke detector's tripped status to the CCN building control. See Fig. 46 and 47, PremierLink wiring schematics.

**FILTER STATUS SWITCH** — This function is available only when PremierLink is configured for (Space) Sensor Mode.

PremierLink control can monitor return filter status in two ways: By monitoring a field-supplied/installed filter-pressure switch or via supply fan runtime hours.

Using switch input: Install the dirty filter pressure switch according to switch manufacturer's instructions, to measure pressure drop across the unit's return filters. Connect one side of the switch's NO contact set to CTB's THERMOSTAT-R terminal. Connect the other side of the NO contact set to TB3-10. Setpoint for Dirty Filter is set at the switch. See Fig. 60.

Filter Switch (NO, close on rising pressure (high drop))



**Fig. 60 — PremierLink Filter Switch Connection**

When the filter switch's NO contact set closes as filter pressure drop increases (indicating dirt-laden filters), the input signal to PremierLink causes the filter status point to read "DIRTY".

**Using Filter Timer Hours** — Refer to PremierLink Installation, Start-up, and Configuration Instructions for instructions on using the PremierLink Configuration screens and on unit alarm sequence.

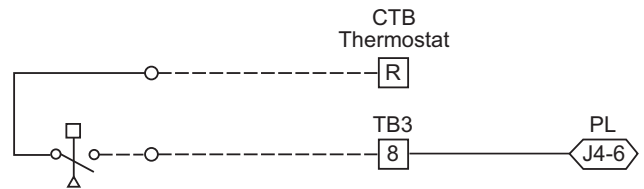
**SUPPLY FAN STATUS SWITCH** — The PremierLink control can monitor supply fan operation through a field-supplied/installed differential pressure switch. This sequence will prevent (or interrupt) operation of unit cooling, heating and economizer functions until the pressure switch contacts are closed indicating proper supply fan operation.

Install the differential pressure switch in the supply fan section according to switch manufacturer's instructions. Arrange

the switch contact to be open on no flow and to close as pressure rises indicating fan operation.

Connect one side of the switch's NO contact set to CTB's THERMOSTAT-R terminal. Connect the other side of the NO contact set to TB3-8. Setpoint for Supply Fan Status is set at the switch. See Fig. 61.

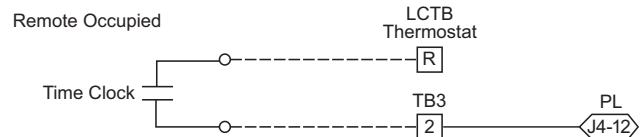
Fan (Pressure) Switch (NO, close on rise in pressure)



**Fig. 61 — PremierLink™ Wiring Fan Pressure Switch Connection**

**REMOTE OCCUPIED SWITCH** — The PremierLink control permits a remote time-clock to override the control's on-board occupancy schedule and place the unit into Occupied mode. This function may also provide a "Door Switch" time delay function that will terminate cooling and heating functions after a 2-20 minute delay.

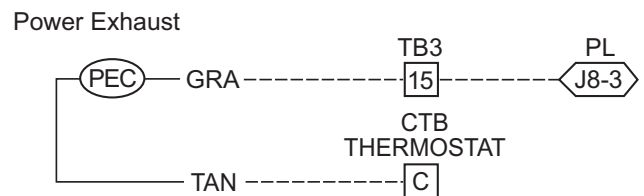
Connect one side of the NO contact set on the timeclock to CTB's THERMOSTAT-R terminal. Connect the other side of the timeclock contact to the unit's TB3-2 terminal (see Fig. 62).



**Fig. 62 — PremierLink Wiring Remote Occupied**

Refer to PremierLink Installation, Start-up, and Configuration Instructions for additional information on configuring the PremierLink control for Door Switch timer function.

**POWER EXHAUST (OUTPUT)** — Connect the accessory Power Exhaust contactor coil(s) per Fig. 63.



**Fig. 63 — PremierLink Power Exhaust Output Connection**

NOTE: The Power Exhaust and Humidi-MiZer® options can not be used with PremierLink controls at the same time as both options require connection at TB3-15 (AUX OUT).

**CCN COMMUNICATION BUS** — The PremierLink controller connects to the bus in a daisy chain arrangement. Negative pins on each component must be connected to respective negative pins, and likewise, positive pins on each component must be connected to respective positive pins. The controller signal pins must be wired to the signal ground pins. Wiring connections for CCN must be made at the 3-pin plug.

At any baud (9600, 19200, 38400 baud), the number of controllers is limited to 239 devices maximum. Bus length may not exceed 4000 ft, with no more than 60 total devices on any 1000-ft section. Optically isolated RS-485 repeaters are required every 1000 ft (305 m).

NOTE: Carrier device default is 9600 band.



Communications Bus Wire Specifications — The CCN Communication Bus wiring is field-supplied and field-installed. It consists of shielded 3-conductor cable with drain (ground) wire. The cable selected must be identical to the CCN Communication Bus wire used for the entire network.

See Table 25 for recommended cable.

**Table 25 — Recommended Cables**

MANUFACTURER	CABLE PART NO.
Alpha	2413 or 5463
American	A22503
Belden	8772
Columbia	02525

NOTE: Conductors and drain wire must be at least 20 AWG, stranded, and tinned copper. Individual conductors must be insulated with PVC, PVC/nylon, vinyl, Teflon, or polyethylene. An aluminum/polyester 100% foil shield and an outer jacket of PVC, PVC/nylon, chrome vinyl, or Teflon with a minimum operating temperature range of -20°C (-4°F) to 60°C (140°F) is required. Do not run communication wire in the same conduit as or next to any AC voltage wiring.

The communication bus shields must be tied together at each system element. If the communication bus is entirely within one building, the resulting continuous shield must be connected to ground at only one single point. If the communication bus cable exits from one building and enters another building, the shields must be connected to the grounds at a lightning suppressor in each building (one point only).

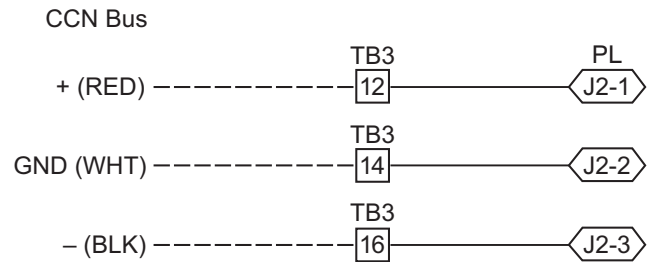
Connecting CCN Bus

NOTE: When connecting the communication bus cable, a color code system for the entire network is recommended to simplify installation and checkout. See Table 26 for the recommended color code.

**Table 26 — Color Code Recommendations**

SIGNAL TYPE	CCN BUS WIRE COLOR	CCN PLUG PIN NUMBER
+	Red	1
Ground	White	2
-	Black	3

Connect the CCN (+) lead (typically RED) to the unit's TB3-12 terminal. Connect the CCN (ground) lead (typically WHT) to the unit's TB3-14 terminal. Connect the CCN (-) lead (typically BLK) to the unit's TB3-16 terminal. See Fig. 64.



**Fig. 64 — PremierLink CCN Bus Connections**



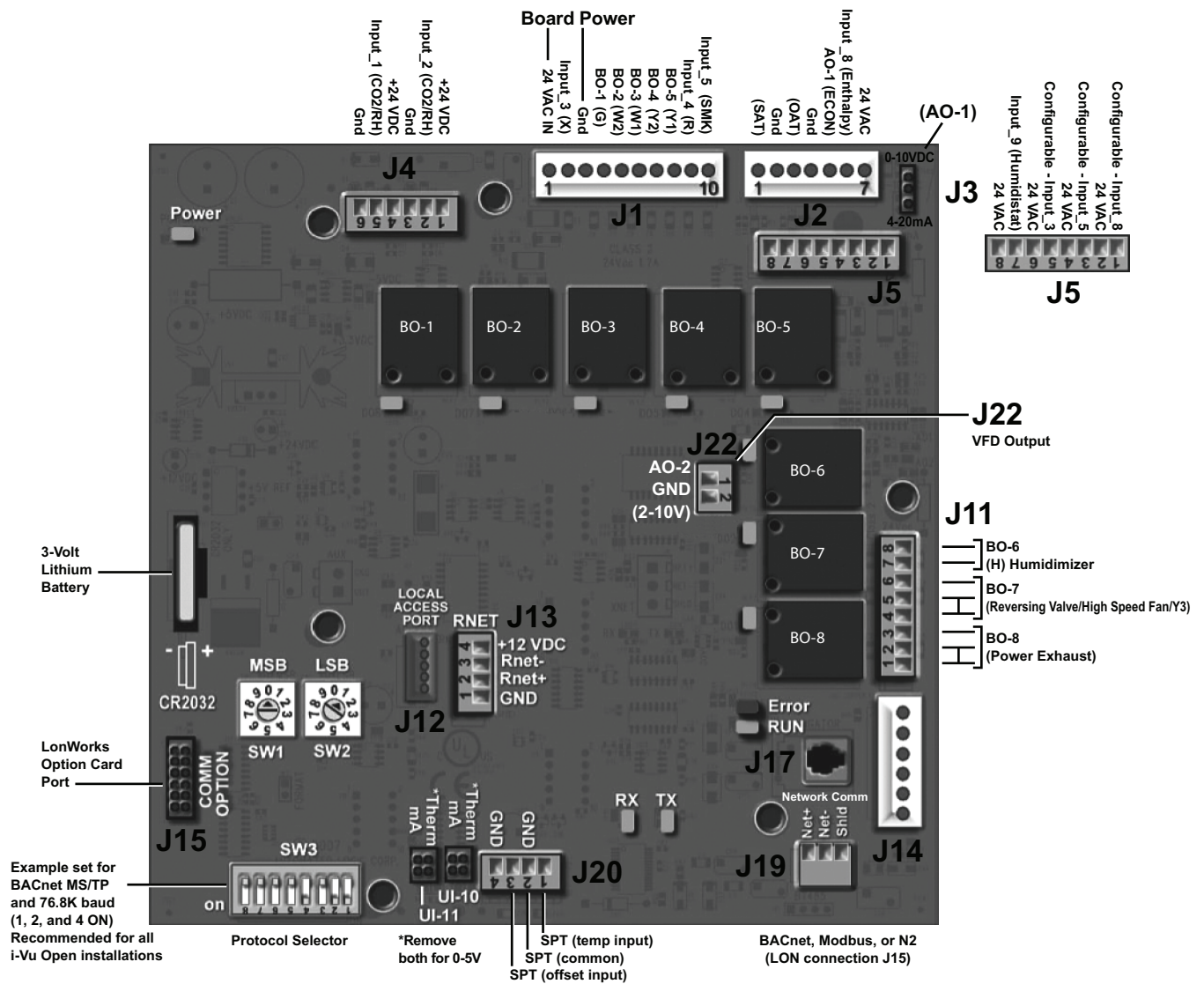
**RTU Open Control System** — The RTU Open control is factory-mounted in the 48TC unit's main control box, to the left of the CTB. See Fig. 65. Factory wiring is completed through harnesses connected to the CTB. Field connections for RTU Open sensors will be made at the Phoenix connectors on the RTU Open board. The factory-installed RTU Open control includes the supply-air temperature (SAT) sensor. The outdoor air temperature (OAT) sensor is included in the FIOP/accessory EconoMiSer® 2 package.

The RTU Open controller is an integrated component of the Carrier rooftop unit. Its internal application programming provides optimum performance and energy efficiency. RTU Open

enables the unit to run in 100% stand-alone control mode, Carrier's i-Vu® Open network, or a Third Party Building Automation System (BAS). On-board DIP switches allow you to select your protocol (and baud rate) of choice among the four most popular protocols in use today: BACnet\*, Modbus†, Johnson N2 and LonWorks\*\* (see Fig. 66 and 67).

Refer to Table 27, RTU Open Controller Inputs and Outputs for locations of all connections to the RTU Open board.

For wiring the RTU Open controller see Fig. 66. For wiring the controller to a unit equipped with a Humidi-MiZer® system see Fig. 67.



**Fig. 65 — RTU Open Multi-Protocol Control Board**

\* BACnet is a registered trademark of ASHRAE (American Society of Heating, Refrigerating and Air-Conditioning Engineers).

† Modbus is a registered trademark of Schneider Electric.

\*\* LonWorks is a registered trademark of Echelon Corporation.

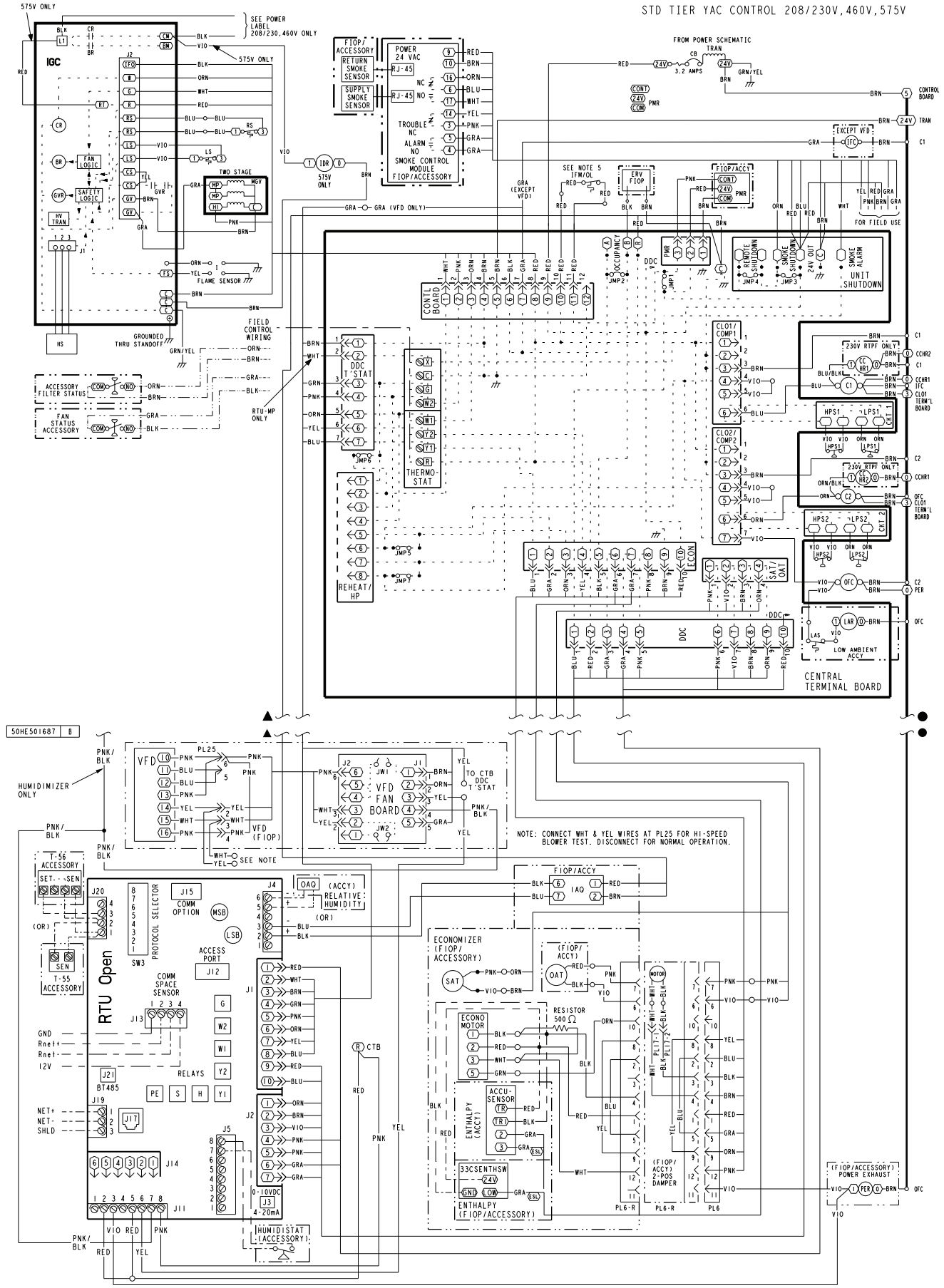


Fig. 66 — Typical RTU Open System Control Wiring Diagram

50HE502181 F

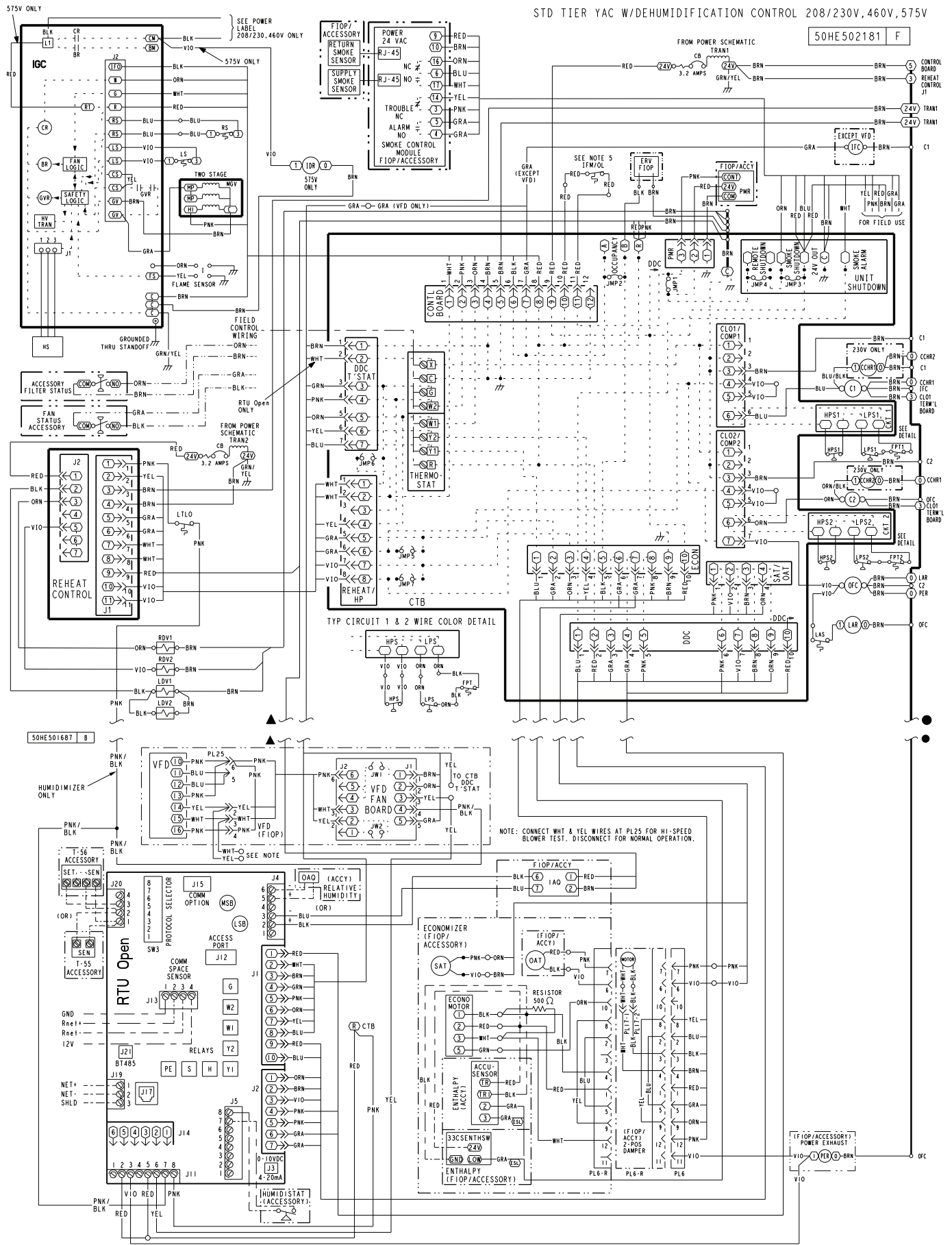


Fig. 67 — Typical RTU Open System Control Wiring Diagram with Humidi-MiZer® System

**Table 27 — RTU Open Controller Inputs and Outputs**

POINT NAME	BACNET OBJECT NAME	TYPE OF I/O	CONNECTION PIN NUMBER (S)
<b>DEDICATED INPUTS</b>			
Space Temp / Zone Temp	zone_temp	AI (10K Thermistor)	J20-1 & 2
Supply Air Temperature	sa_temp	AI (10K Thermistor)	J2-1 & 2
Outside Air Temperature	oa_temp	AI (10K Thermistor)	J2-3 & 4
Space Temperature Offset Pot	stpt_adj_offset	AI (100K Potentiometer)	J20-3 & 4
Safety Chain Feedback	safety_status	DI (24 VAC)	J1-9
Compressor Safety Status <sup>1</sup>	comp_status	DI (24 VAC)	J1-2
Fire Shutdown Status	firedown_status	DI (24 VAC)	J1-10
Enthalpy Status	enthalpy_status	DI (24 VAC)	J2-6 & 7
Humidistat Input Status	humstat_status	DI (24 VAC)	J5-7 & 8
Zone Temperature	n/a	n/a	J13-1-4
<b>CONFIGURABLE INPUTS<sup>4</sup></b>			
Indoor Air CO <sub>2</sub>	iaq	AI (4-20 mA)	J4-2 & 3 or J4-5 & 6
Outdoor Air CO <sub>2</sub>	oaq	AI (4-20 mA)	
Space Relative Humidity	space_rh	AI (4-20 mA)	
Supply Fan Status*	sfan_status	DI (24 VAC)	J5-1 or J5-3 or J5-5
Filter Status*	filter_status	DI (24 VAC)	
Door Contact Input*	door_contact_status	DI (24 VAC)	
Occupancy Contact*	occ_contact_status	DI (24 VAC)	
<b>OUTPUTS</b>			
Economizer Output	econ_output	AO (4-20mA)	J2-5
Supply Fan Relay State	sfan	DO Relay (24VAC, 1A)	J1-4
Compressor 1 Relay State	comp_1	DO Relay (24VAC, 1A)	J1-8
Compressor 2 Relay State	comp_2	DO Relay (24VAC, 1A)	J1-7
Heat Stage 1 Relay State	heat_1	DO Relay (24VAC, 1A)	J1-6
Heat Stage 2 Relay State	heat_2	DO Relay (24VAC, 1A)	J1-5
Power Exhaust Relay State	pexh	DO Relay (24VAC, 1A)	J11-1 & 3
Dehumidification Relay	dehum	DO Relay (24VAC, 1A)	J11-7 & 8

**LEGEND**

- AI** — Analog Input
- AO** — Analog Output
- DI** — Discrete Input
- DO** — Discrete Output

\* These inputs (if installed) take the place of the default input on the specific channel according to schematic. Parallel pins J5 -1 = J2 -6, J5 -3 = J1 -10, J5 - 5 = J1 - 2 are used for field-installation.

The RTU Open controller requires the use of a Carrier space sensor. A standard thermostat cannot be used with the RTU Open system.

**SUPPLY AIR TEMPERATURE (SAT) SENSOR** — On FIOP-equipped 48TC unit, the unit is supplied with a supply-air temperature (SAT) sensor (33ZCSENSAT). This sensor is a tubular probe type, approx 6-inches (152 mm) in length. It is a nominal 10-k ohm thermistor.

The SAT is factory-wired. The SAT probe is wire-tied to the supply-air opening in its shipping position. Remove the sensor for installation. Re-position the sensor in the flange of the supply-air opening or in the supply air duct (as required by local codes). Drill or punch a 1/2-in. hole in the flange or duct. Use two field-supplied, self-drilling screws to secure the sensor probe in a horizontal orientation. See Fig. 48.

**OUTDOOR AIR TEMPERATURE (OAT) SENSOR** — The OAT is factory-mounted in the EconoMiSer2 (FIOP or accessory). It is a nominal 10k ohm thermistor attached to an eyelet mounting ring.

**ECONOMISER® 2** — The RTU Open control is used with EconoMiSer 2 (option or accessory) for outdoor air management. The damper position is controlled directly by the RTU Open control; EconoMiSer2 has no internal logic device.

Outdoor air management functions can be enhanced with field-installation of these accessory control devices:

- Enthalpy control (outdoor air or differential sensors)
- Space CO<sub>2</sub> sensor
- Outdoor air CO<sub>2</sub> sensor

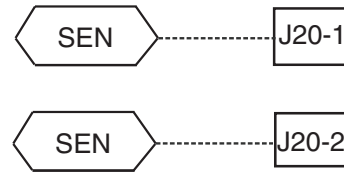
**Field Connections** — Field connections for accessory sensors and input devices are made the RTU Open, at plugs J1, J2, J4, J5, J11 and J20. All field control wiring that connects to the RTU Open must be routed through the raceway built into the corner post as shown in Fig. 32. The raceway provides the UL required clearance between high and low-voltage wiring. Pass the control wires through the hole provided in the corner post, then feed the wires thorough the raceway to the RTU Open. Connect to the wires to the removable Phoenix connectors and then reconnect the connectors to the board.

**SPACE TEMPERATURE (SPT) SENSORS** — There are two types of SPT sensors available from Carrier, resistive input non-communicating (T55, T56, and T59) and Rnet communicating (SPS, SPPL, SPP, and SPPF) sensors. Each type has a variety of options consisting of: timed override button, set point adjustment, a LCD screen, and communication tie in. Space temperature can be also be written to from a building network or zoning system. However, it is still recommended that return air duct sensor be installed to allow stand-alone operation for back-up. Refer to the configuration section for details on controller configurations associated with space sensors.

- 33ZCT55SPT, space temperature sensor with override button (T-55)
- 33ZCT56SPT, space temperature sensor with override button and setpoint adjustment (T-56)
- 33ZCT59SPT, space temperature sensor with LCD (liquid crystal display) screen, override button, and setpoint adjustment (T-59)

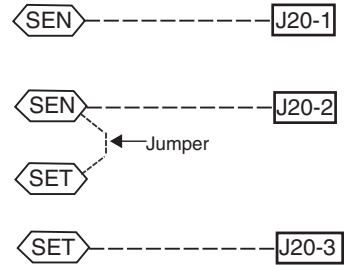
Use 20 gauge wire to connect the sensor to the controller. The wire is suitable for distances of up to 500 ft (152 m). Use a three-conductor shielded cable for the sensor and setpoint adjustment connections. If the setpoint adjustment (slidebar) is not required, then an unshielded, 18 or 20 gauge, two-conductor, twisted pair cable may be used.

**Connect T-55** — See Fig. 49 for typical T-55 internal connections. Connect the T-55 SEN terminals to RTU Open J20-1 and J20-2. See Fig. 68.



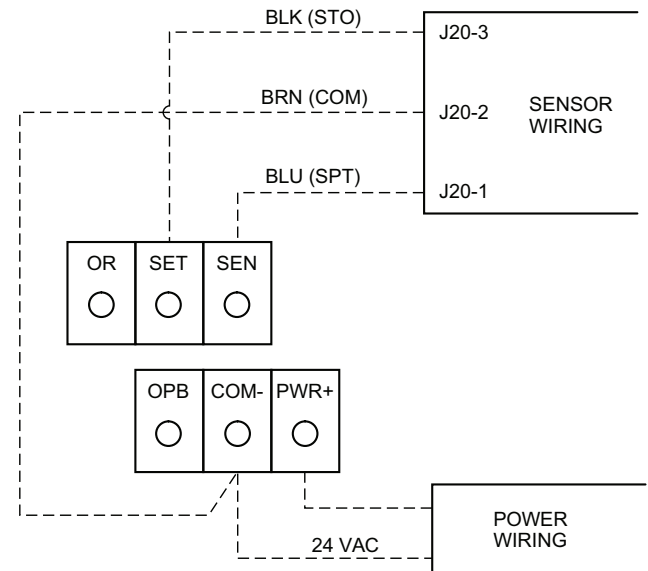
**Fig. 68 — RTU Open T-55 Sensor Connections**

**Connect T-56** — See Fig. 49 for T-56 internal connections. Install a jumper between SEN and SET terminals as illustrated. Connect T-56 terminals to RTU Open J20-1, J20-2 and J20-3 per Fig. 69.



**Fig. 69 — RTU Open T-56 Sensor Connections**

**Connect T-59** — The T-59 space sensor requires a separate, isolated power supply of 24 VAC. See Fig. 70 for internal connections at the T-59. Connect the SEN terminal (BLU) to RTU Open J20-1. Connect the COM terminal (BRN) to J20-2. Connect the SET terminal (STO or BLK) to J20-3.



NOTE: Must use a separate isolated transformer.

**Fig. 70 — Space Temperature Sensor Typical Wiring (33ZCT59SPT)**

**INDOOR AIR QUALITY (CO<sub>2</sub>) SENSOR** — The indoor air quality sensor accessory monitors space carbon dioxide (CO<sub>2</sub>) levels. This information is used to monitor IAQ levels. Several types of sensors are available, for wall mounting in the space or in return duct, with and without LCD display, and in combination with space temperature sensors. Sensors use infrared technology to measure the levels of CO<sub>2</sub> present in the space air.

The CO<sub>2</sub> sensors are all factory set for a range of 0 to 2000 ppm and a linear mA output of 4 to 20. Refer to the instructions supplied with the CO<sub>2</sub> sensor for electrical requirements and



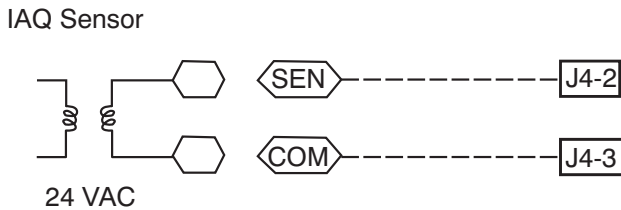
terminal locations. See Fig. 54 for typical CO<sub>2</sub> sensor wiring schematic.

To accurately monitor the quality of the air in the conditioned air space, locate the sensor near a return-air grille (if present) so it senses the concentration of CO<sub>2</sub> leaving the space. The sensor should be mounted in a location to avoid direct breath contact.

Do not mount the IAQ sensor in drafty areas such as near supply ducts, open windows, fans, or over heat sources. Allow at least 3 ft (0.9 m) between the sensor and any corner. Avoid mounting the sensor where it is influenced by the supply air; the sensor gives inaccurate readings if the supply air is blown directly onto the sensor or if the supply air does not have a chance to mix with the room air before it is drawn into the return airstream.

**Wiring the Indoor Air Quality Sensor** — For each sensor, use two 2-conductor 18 AWG (American Wire Gauge) twisted-pair cables (unshielded) to connect the separate isolated 24 vac power source to the sensor and to connect the sensor to the control board terminals.

To connect the sensor to the control, identify the positive (4 to 20 mA) and ground (SIG COM) terminals on the sensor. See Fig. 54. Connect the 4-20 mA terminal to RTU Open J4-2 and connect the SIG COM terminal to RTU Open J4-3. See Fig. 71.

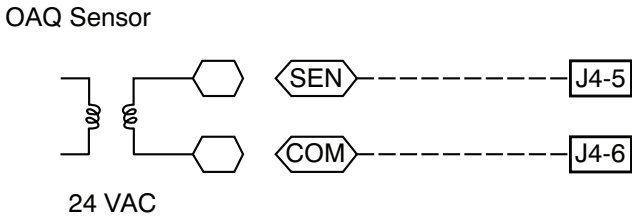


**Fig. 71 — RTU Open/Indoor CO<sub>2</sub> Sensor (33ZCSENCO2) Connections**

**OUTDOOR AIR QUALITY SENSOR (P/N 33ZCSENCO2 PLUS WEATHERPROOF ENCLOSURE)** — The outdoor air CO<sub>2</sub> sensor is designed to monitor carbon dioxide (CO<sub>2</sub>) levels in the outside ventilation air and interface with the ventilation damper in an HVAC system. The OAQ sensor is packaged with an outdoor cover. The outdoor air CO<sub>2</sub> sensor must be located in the economizer outside air hood.

**Wiring the Outdoor Air CO<sub>2</sub> Sensor** — A dedicated power supply is required for this sensor. A two-wire cable is required to wire the dedicated power supply for the sensor. The two wires should be connected to the power supply and terminals 1 and 2.

To connect the sensor to the control, identify the positive (4 to 20 mA) and ground (SIG COM) terminals on the OAQ sensor. Connect the 4 to 20 mA terminal to RTU Open J4-5. Connect the SIG COM terminal to RTU Open J4-6. See Fig. 72.



**Fig. 72 — RTU Open / Outdoor CO<sub>2</sub> Sensor (33ZCSENCO2) Connections**

**SPACE RELATIVE HUMIDITY SENSOR OR HUMIDISTAT**

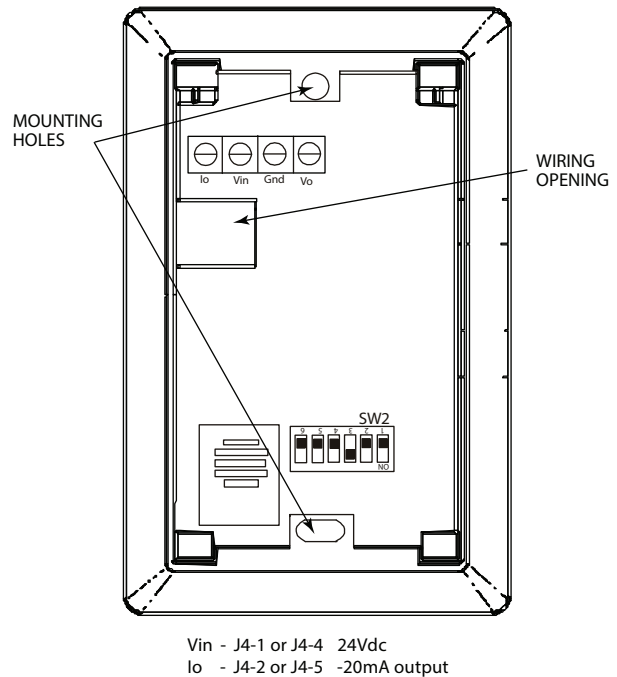
NOTE: The accessory space relative humidity sensor and humidistat do not apply to size 30 units.

**Humidi-MiZer® Control Wiring** — In units equipped with the Humidi-MiZer option there are two pink (PNK) wires loose in the control box used to control the dehumidification function of the unit. These pink wires are meant to be tied to a space humidistat or thermidistat on an electromechanical unit. On RTU Open equipped units these pink wires must be connected to J11-7 and 8 to allow the Open board to operate the dehumidification function for the unit. Disconnect the J11 Phoenix style connector from the board and use the plug screws to secure the pink wires in pins 7 and 8, reconnect the plug to the board at J11.

**Relative Humidity Sensors (Space or Duct Mounted)** — The accessory space humidity sensor (33ZCSENSRH-01) or duct humidity sensor (33ZCSENDRH-01) is used to measure the relative humidity of air within the space or return air duct. The RH reading is used to control the Humidi-MiZer option of the rooftop unit. For wiring distances up to 500 ft (152 m), use a 3-conductor, 18 or 20 AWG shielded cable. The shield must be removed from the sensor end of the cable and grounded at the unit end. The current loop power for sensor is provided by the RTU Open controller as 24 vdc. Refer to the instructions supplied with the RH sensor for the electrical requirements and terminal locations. RTU Open configurations must be changed after adding an RH sensor. See Fig. 73 and 74 for typical RH sensor wiring.

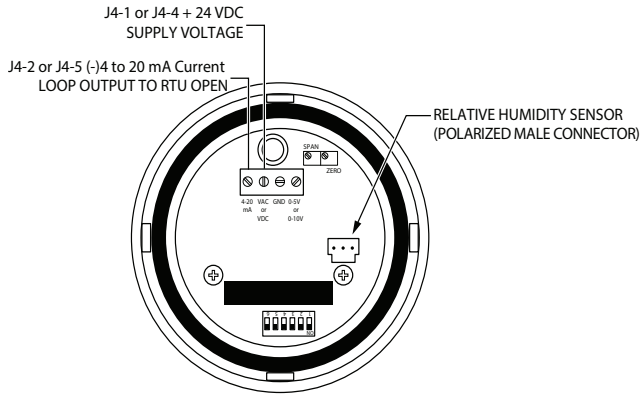
- J4-1 or J4-4 = 24vdc loop power
- J4-2 or J4-5 = 4-20mA signal input

NOTE: The factory default for dehumidification control is normally open humidistat.



**Fig. 73 — Space Relative Humidity Sensor Typical Wiring**

**Humidistat** — The accessory humidistat provides the RTU Open insight to the relative humidity in the space. The humidistat reads the RH level in the space and compares it to its set-point to operate a dry contact. The humidistat is a dedicated input on the configurable input 9 and tells the RTU Open when the RH level is HIGH or LOW. The normal condition for humidity is LOW. A normally open humidistat is the factory default control for the Humidi-MiZer® option.



**Fig. 74 — Duct Relative Humidity Sensor Typical Wiring**

To wire in the field:

- J5-8 = 24 VAC source for dry contact
- J5-7 = Signal input

**SMOKE DETECTOR/FIRE SHUTDOWN (FSD)** — On 48TC units equipped with factory-installed Smoke Detector(s), the smoke detector controller implements the unit shutdown through its NC contact set connected to the unit’s CTB input. The FSD function is initiated via the smoke detector’s Alarm NO contact set. The RTU Open controller communicates the smoke detector’s tripped status to the BAS building control. See Fig. 66 and Fig. 67, the RTU Open wiring schematics.

The Fire Shutdown Switch configuration, **MENU→Config→Inputs→input 5**, identifies the normally open status of this input when there is no fire alarm.

**CONNECTING DISCRETE INPUTS**

**Filter Status**—The filter status accessory is a field-installed accessory. This accessory detects plugged filters. When installing this accessory, the unit must be configured for filter status by setting **MENU→Config→Inputs→input 3, 5, 8, or 9** to Filter Status and normally open (N/O) or normally closed (N/C). Input 8 or 9 is recommended for easy of installation. Refer to Fig. 65-67 for wire terminations at J5.

**Fan Status** — The fan status accessory is a field-installed accessory. This accessory detects when the indoor fan is blowing air. When installing this accessory, the unit must be configured for fan status by setting **MENU→Config→Inputs→input 3,**

**5, 8, or 9** to Fan Status and normally open (N/O) or normally closed (N/C). Input 8 or 9 is recommended for easy of installation. Refer to Fig. 65-67 for wire terminations at J5.

**Remote Occupancy** — The remote occupancy accessory is a field-installed accessory. This accessory overrides the unoccupied mode and puts the unit in occupied mode. When installing this accessory, the unit must be configured for remote occupancy by setting **MENU→Config→Inputs→input 3, 5, 8, or 9** to Remote Occupancy and normally open (N/O) or normally closed (N/C).

Also set **MENU→Schedules→occupancy source** to DI on/off. Input 8 or 9 is recommended for easy of installation. Refer to Fig. 65 and Table 28 for wire terminations at J5.

**Power Exhaust (output)** — The relay used by the RTU Open board to control power exhaust is a dry contact which means it does not have 24 vac. This 24 vac must be connected to the relay to allow it to operate the power exhaust relay in the PE accessory. A 24 vac source must be provided to J11-2 on the RTU Open control board. This can be provided by the unit’s transformer from various sources. The “R” terminal on the unit’s low voltage terminal board (LVTB) is a logical source. Refer to Fig. 65-67 for wire terminations at J11.

**Communication Wiring-Protocols** — Protocols are the communication languages spoken by control devices. The main purpose of a protocol is to communicate information in the most efficient method possible. Different protocols exist to provide different kinds of information for different applications. In the BAS application, many different protocols are used, depending on manufacturer. Protocols do not change the function of a controller; just make the front end user different.

The RTU Open can be set to communicate on four different protocols: BACnet, Modbus, N2, and LonWorks. Switch 3 (SW3) on the board is used to set protocol and baud rate. Switches 1 and 2 (SW1 and SW2) are used to set the board’s network address. See Fig. 75 and 76 for protocol switch settings and address switches. The third party connection to the RTU Open is through plug J19. See Fig. 77 for wiring.

NOTE: Power must be cycled after changing the SW1-3 switch settings.

Refer to the RTU Open v3 Integration Guide for more detailed information on protocols third party wiring and networking.

**SW3 PROTOCOL SELECTION**

PROTOCOL	DS8	DS7	DS6	DS5	DS4	DS3	DS2	DS1
<b>BACnet MS/TP (Master)</b>	Unused	OFF	OFF	OFF	ON	OFF	Select Baud	Select Baud
<b>Modbus (Slave)</b>	Unused	OFF	OFF	ON	ON	OFF	Select Baud	Select Baud
<b>N2 Slave</b>	Unused	OFF	OFF	OFF	ON	ON	OFF	OFF
<b>LonWorks</b>	Unused	ON	ON	OFF	ON	OFF	OFF	ON

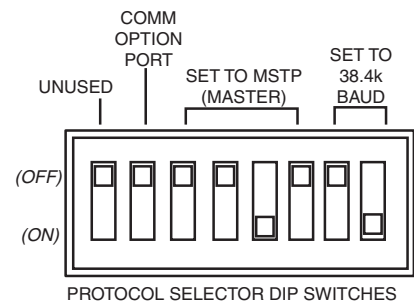
**LEGEND**

**DS** — DIP Switch

NOTE: BACnet MS/TP SW3 example shown.

**Baud Rate Selection**

BAUD RATE	DS2	DS1
<b>9,600</b>	OFF	OFF
<b>19,200</b>	ON	OFF
<b>38,400</b>	OFF	ON
<b>76,800</b>	ON	ON



**Fig. 75 — RTU Open SW3 DIP Switch Settings**



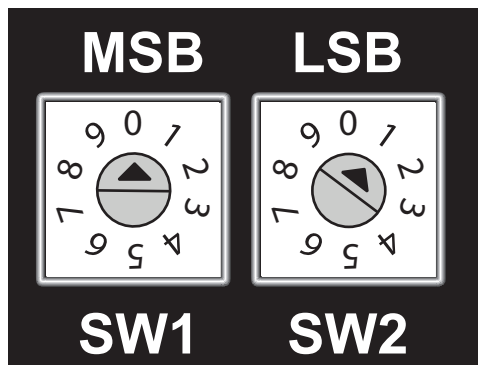


Fig. 76 — RTU Open Address Switches

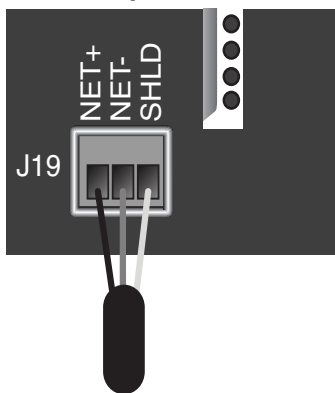


Fig. 77 — Network Wiring

### Local Access

**WALL MOUNTED EQUIPMENT TOUCH** — The Equipment Touch is a wall mounted interface used to connect to the RTU Open to access the control information, read sensor values, and maintenance. This is an accessory interface that does not come with the RTU Open controller. Wire the Equipment Touch to the RTU Open's J13 local access port. There are 2 password protected levels in the display (User and Admin). See the Equipment Touch Installation and Setup Guide for more information. See Appendix A in the guide for navigation and screen content.

**FIELD ASSISTANT** — Field Assistant is a computer program included with the purchase of the Tech Tool Kit (USB-TKIT). This is a field Tech Tool to set-up, service, or download application software to the RTU Open controller and includes a USB Link Cable. The link cable connects a USB port to the J12 local access port. The Field Assistant's menu structure is similar and functions the same as i-Vu® controller. See Fig. 78.

**RTU OPEN TROUBLESHOOTING** — Troubleshooting is accomplished by viewing the communication LEDs, see Fig. 65. The LEDs indicate if the controller is speaking to the devices on the network. The LEDs should reflect communication traffic based on the baud rate set. The higher the baud rate the more solid the LEDs will appear. See Table 28.

**NOTE:** Refer to the RTU Open Multi-Protocol Controller Controls, Start-Up, Operation, and Troubleshooting manual for complete configuration of RTU Open, operating sequences and troubleshooting information. Refer to the RTU Open v3 Integration Guide for details on configuration and troubleshooting of connected networks. Have a copy of these manuals available at unit start-up.

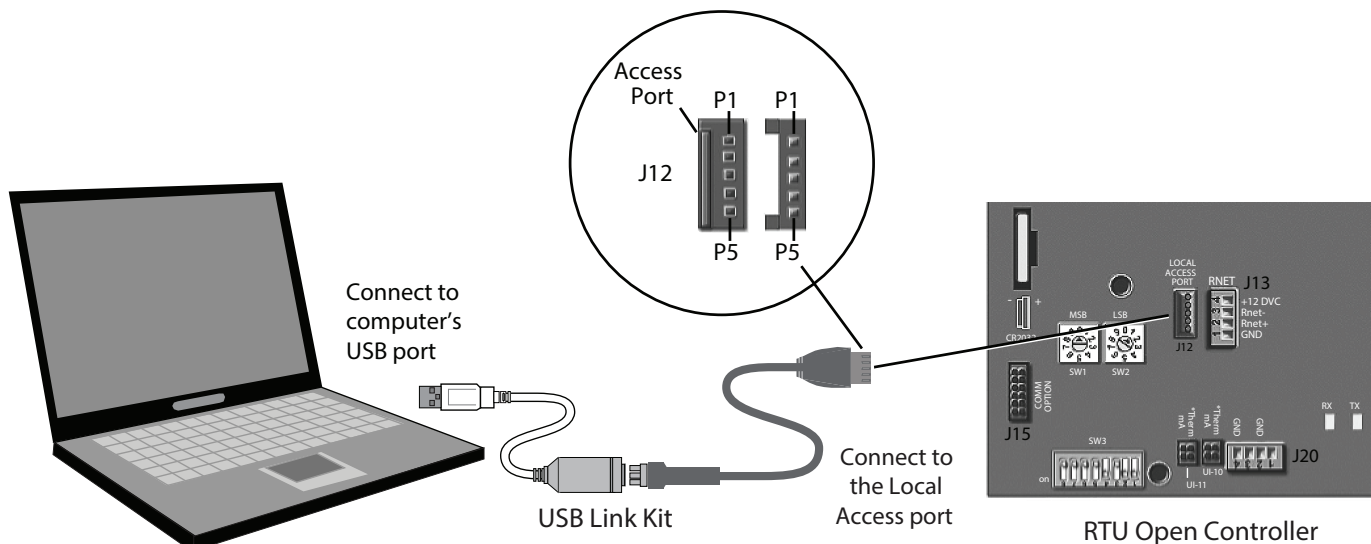


Fig. 78 — PC Running Field Assistant

**Table 28 — LEDs**

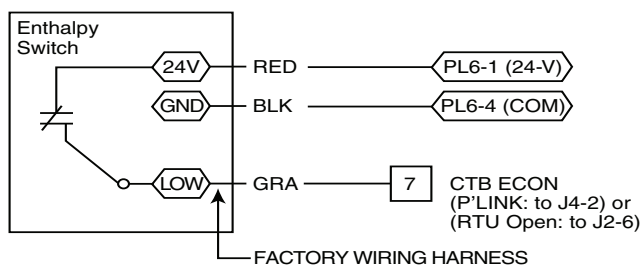
(The LEDs on the RTU Open show the status of certain functions)

IF THIS LED IS ON...	THE STATUS IS...	
<b>Power</b>	RTU Open has power	
<b>Rx</b>	RTU Open is receiving data from the network segment	
<b>Tx</b>	RTU Open is transmitting data over the network segment	
<b>DO#</b>	The digital output is active	
The <b>Run</b> and <b>Error</b> LEDs indicate control module and network status		
<b>2 Flashes Per Second</b>	Off	Normal
<b>2 Flashes Per Second</b>	2 flashes, alternating with <b>Run</b> LED	Five minute auto-restart delay after system error
<b>2 Flashes Per Second</b>	3 flashes, then off	Control module has just been formatted
<b>2 Flashes Per Second</b>	4 flashes, then pause	Two or more devices on this network have the same MSTP network address
<b>2 Flashes Per Second</b>	On	Exec halted after frequent system errors or control programs halted
<b>5 Flashes Per Second</b>	On	Exec start-up aborted, Boot is running
<b>5 Flashes Per Second</b>	Off	Firmware transfer in progress, Boot is running
<b>7 Flashes Per Second</b>	7 flashes per second, alternating with <b>Run</b> LED	Ten second recovery period after brownout
<b>14 Flashes Per Second</b>	14 flashes per second, alternating with <b>Run</b> LED	Brownout
<b>On</b>	On	Failure. Try the following solutions: <ul style="list-style-type: none"> <li>• Turn RTU Open off, then on</li> <li>• Format RTU Open</li> <li>• Download memory to RTU Open</li> <li>• Replace RTU Open</li> </ul>

**Outdoor Air Enthalpy Control — (P/N 33CSENTHSW)** — The enthalpy control is available as a field-installed accessory to be used with the EconoMiSer2 damper system. The outdoor air enthalpy sensor is part of the enthalpy control. (The separate field-installed accessory return air enthalpy sensor (33CSENSEN) is required for differential enthalpy control see Fig. 79).

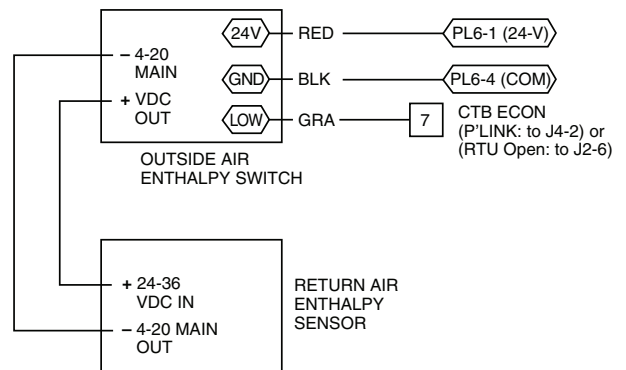
Locate the enthalpy control in the economizer next to the Actuator Motor. Locate two GRA leads in the factory harness and connect the gray lead labeled “ESL” to the terminal labeled “LOW”. See Fig. 79. Connect the enthalpy control power input terminals to economizer actuator power leads RED (connect to 24V) and BLK (connect to GND).

The outdoor enthalpy changeover setpoint is set at the enthalpy controller.



**Fig. 79 — Enthalpy Switch (33CSENTHSW) Connections**

**DIFFERENTIAL ENTHALPY CONTROL** — Differential enthalpy control is provided by sensing and comparing the outside air and return air enthalpy conditions. Install the outdoor air enthalpy control as described above. Add and install a return air enthalpy sensor (see Fig. 80).



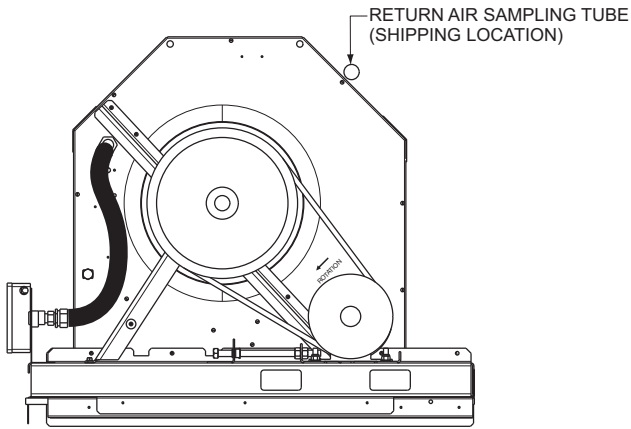
**Fig. 80 — Outside and Return Air Enthalpy Sensor Wiring**

To wire the return air enthalpy sensor, perform the following:

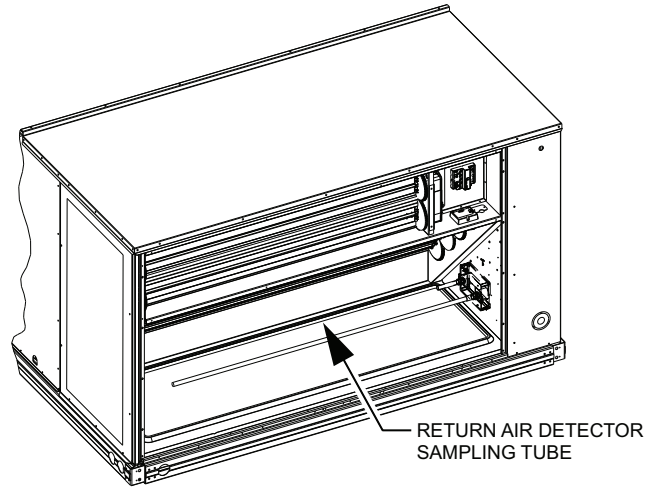
1. Use a 2-conductor, 18 or 20 AWG, twisted pair cable to connect the return air enthalpy sensor to the enthalpy controller.
2. Connect the field-supplied RED wire to (+) spade connector on the return air enthalpy sensor and the (+) terminal on the enthalpy controller. Connect the BLK wire to (-) spade connector on the return air enthalpy sensor and the (-) terminal on the enthalpy controller.

**Smoke Detectors** — Smoke detectors are available as factory-installed options on 48TC models. Smoke detectors may be specified for Supply Air only or for Return Air without or with economizer or in combination of Supply Air and Return Air. The unit is factory-configured for immediate smoke detector shutdown operation; additional wiring or modifications to unit terminal board may be necessary to complete the unit and smoke detector configuration to meet project requirements.

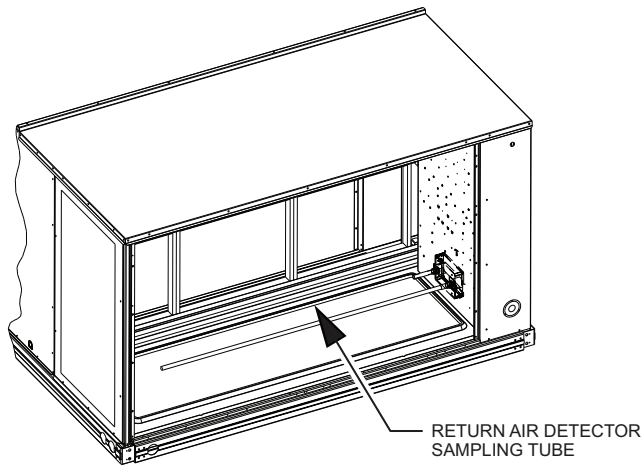
**RETURN AIR SENSOR TUBE INSTALLATION** — The return air sampling tube is shipped in the unit’s supply fan section, attached to the blower housing (see Fig. 81). Its operating location is in the return air section of the unit (see Fig. 82, unit without economizer, or Fig. 83, unit with economizer), inserted into the return air sensor module housing which protrudes through the back of the control box.



**Fig. 81 — Typical Supply Air Smoke Detector Sensor Location**



**Fig. 83 — Return Air Sampling Tube Location in Unit with Economizer**



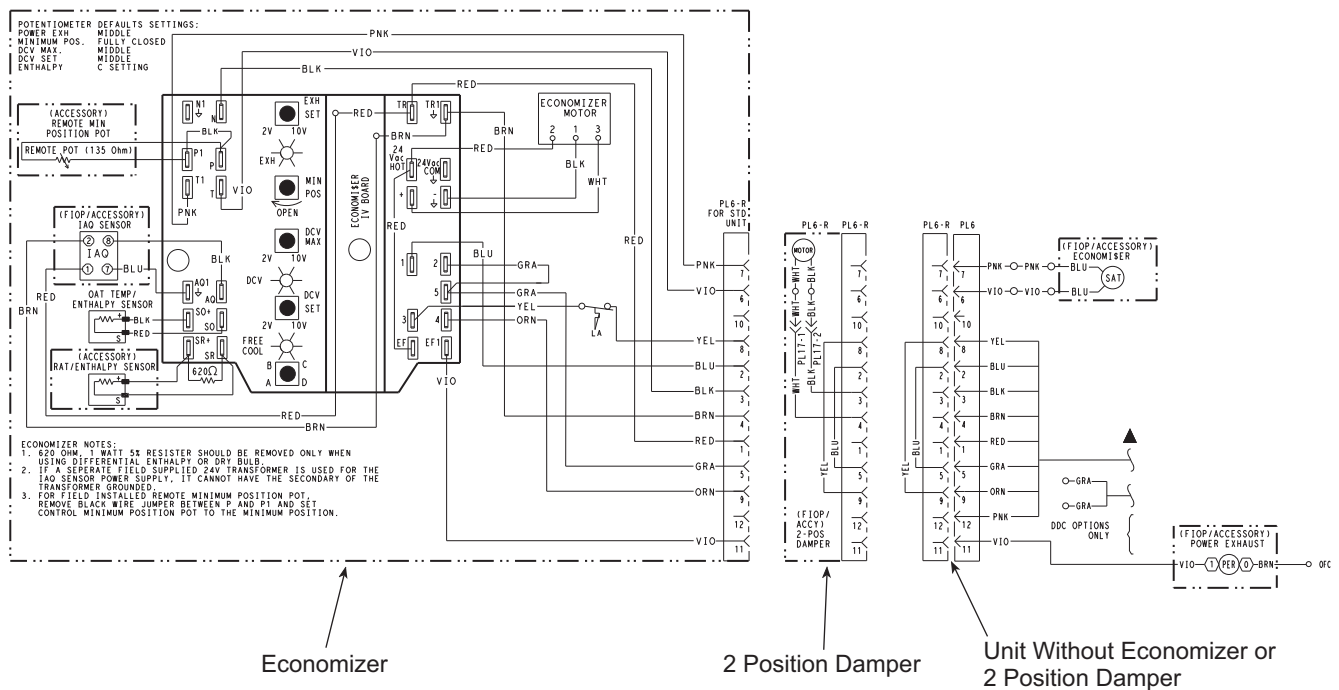
**Fig. 82 — Return Air Sampling Tube Location in Unit without Economizer**

To install the return air sensor sampling tube:

1. Remove the tube from its shipping location.
2. Open the unit end to access the return air sensor (located on right-hand partition).
3. Orient the tube's sampling holes into the return air flow direction. Position the sampling holes on the bottom of the tube, facing into the bottom return duct opening.
4. Insert the sampling tube into the return air sensor module until the tube snaps into position.
5. Replace end panel or outside air hood.

**SMOKE DETECTOR TEST MAGNET** — Locate the magnet; it is shipped in the control box area.

**ADDITIONAL APPLICATION DATA** — Refer to the application data sheet titled "Factory-Installed Smoke Detector, for Small and Medium Rooftop Units 2 to 25 Tons" for discussions on additional control features of these smoke detectors including multiple unit coordination.



**Fig. 84 — EconoMiSer® IV Wiring**

**Step 13 — Adjust Factory- Installed Options**

**ECONOMISER IV OCCUPANCY SWITCH** — Refer to Fig. 84 for general EconoMiSer IV wiring. External occupancy control is managed through a connection on the Controls Connections Board.

If external occupancy control is desired, connect a time clock or remotely controlled switch (closed for Occupied, open for Unoccupied sequence) at terminals marked OCCUPANCY on CTB. Remove or cut jumper JMP 2 to complete the installation.

**Step 14 — Install Accessories** — Available accessories include:

- Roof curb
- Thru-base connection kit (must be installed before unit is set on curb)
- LP conversion kit
- Manual outside air damper
- High altitude gas kit
- Flue discharge deflector
- Low ambient controls
- Thermostat/sensor
- Two-position motorized outside air damper
- EconoMiSer2 (without control/for external signal and integrated barometric relief)
- EconoMiSer IV (with control and integrated barometric relief)
- Power exhaust
- Differential dry-bulb sensor (EconoMiSer IV)
- Outdoor enthalpy sensor
- Differential enthalpy sensor
- CO<sub>2</sub> sensor
- DDC interface (PremierLink)

- Louvered hail guard
- Phase monitor control
- Winter start kit

Refer to separate installation instructions for information on installing these accessories.

**Step 14 — Check Belt Tension** — Measure the belt span length as shown in Fig. 85. Calculate the required deflection by multiplying the belt span length by 1/64. For example, if the belt span length is 32 inches: 32 x 1/64 = 1/2 inch deflection.

**BELT FORCE — DEFLECTION METHOD** — Check the belt tension with a spring-force belt force deflection gauge (available from drive belt manufacturer).

1. Place a straightedge along the belt between the two pulleys. Measure the distance between the motor shaft and the blower shaft.
2. Set the tension gauge to the desired tension (see Table 1 in Fig. 85). Place the large O-ring at that point.
3. Press the tension checker downward on the belt until the large O-ring is at the bottom of the straightedge.
4. Adjust the belt tension as needed.

Adjust belt tension by loosening the motor mounting plate front bolts and rear bolt (see Fig. 86) and slide the plate towards the fan (to reduce tension) or away from the fan (to increase tension). Ensure the blower shaft and motor shaft are parallel to each other (pulleys aligned). Tighten all bolts securely when finished.

**BELT TENSION METHOD** — Requires belt tension gauge that measures tension in belt in units of lbs force (see Fig. 85).

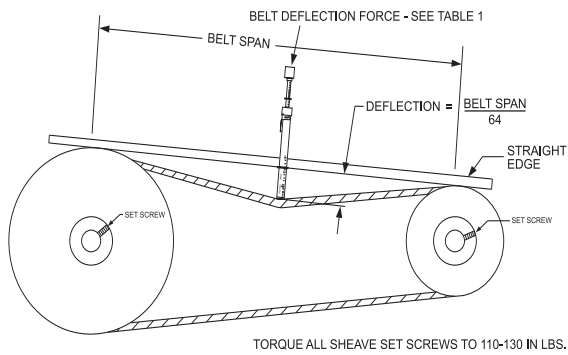


Table 1

BELT CROSS SECTION	SMALLEST SHEAVE DIAMETER	BELT DEFLECTION FORCE (LBS)			
		UNNOTCHED BELTS		NOTCHED BELTS	
		USED	NEW	USED	NEW
A, AX	3.0-3.6	3.7	5.5	4.1	6.1
	3.8-4.8	4.5	6.8	5.0	7.4
	5.0-7.0	5.4	8.0	5.7	8.4
B, BX	3.4-4.2	—	—	4.9	7.2
	4.4-5.6	5.3	7.9	7.1	10.5
	5.8-8.6	6.3	9.4	8.5	12.6

Table 2

BELT CONDITION	TENSION FORCE IN BELT (LBS)
New	100
Used	80

Fig. 85 — V-Belt Force Label

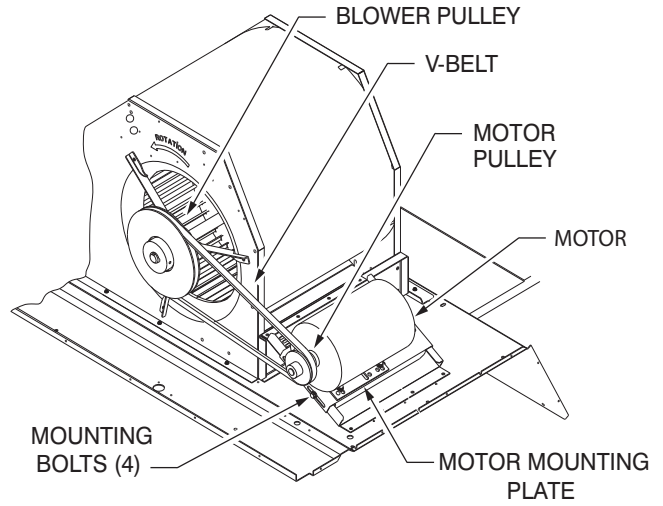


Fig. 86 — Belt Drive Motor Mounting

**Pre-Start and Start-Up** — This completes the mechanical installation of the unit. Refer to the unit's Service Manual for detailed Pre-Start and Start-Up instructions. Download the latest versions from HVAC Partners ([www.hvacpartners.com](http://www.hvacpartners.com)).

**START-UP CHECKLIST — 48TC 17-30 SINGLE PACKAGE ROOFTOP WITH  
HEAT/ELECTRIC COOLING WITH PURON® (R-410A) REFRIGERANT**

**NOTE: To avoid injury to personnel and damage to equipment or property when completing the procedures listed in this start-up checklist, use good judgment, follow safe practices, and adhere to the safety considerations/information as outlined in preceding sections of this Installation Instruction document.**

**I. PRELIMINARY INFORMATION**

MODEL NO. JOB NAME \_\_\_\_\_  
SERIAL NO. ADDRESS \_\_\_\_\_  
START-UP DATE \_\_\_\_\_  
TECHNICIAN NAME \_\_\_\_\_  
ADDITIONAL ACCESSORIES \_\_\_\_\_

**II. PRE-START-UP**

Verify that job site voltage agrees with voltage listed on rating plate (Y/N) \_\_\_\_\_  
Verify that all packaging materials have been removed from unit (Y/N) \_\_\_\_\_  
Remove all shipping hold down bolts and brackets per installation instructions (Y/N) \_\_\_\_\_  
Verify that condensate connection is installed per installation instructions (Y/N) \_\_\_\_\_  
Verify that flue hood is installed (Y/N) \_\_\_\_\_  
Check refrigerant piping for indications of leaks; investigate and repair if necessary (Y/N) \_\_\_\_\_  
Check gas piping for leaks (Y/N) \_\_\_\_\_  
Check all electrical connections and terminals for tightness (Y/N) \_\_\_\_\_  
Check that return (indoor) air filters are clean and in place (Y/N) \_\_\_\_\_  
Verify that unit installation is level (Y/N) \_\_\_\_\_  
Check fan wheels and propeller for location in housing/orifice and setscrew tightness (Y/N) \_\_\_\_\_  
Check to ensure that electrical wiring is not in contact with refrigerant lines or sharp metal edges (Y/N) \_\_\_\_\_  
Check pulley alignment and belt tension per installation instructions (Y/N) \_\_\_\_\_

**II. START-UP (Refer to Unit Service/Maintenance Manual for Start-Up Instructions)**

**ELECTRICAL**

Supply Voltage	L1-L2 _____	L2-L3 _____	L3-L1 _____
Compressor Amps 1	L1 _____	L2 _____	L3 _____
Compressor Amps 2	L1 _____	L2 _____	L3 _____
Indoor Fan Amps	L1 _____	L2 _____	L3 _____
Outdoor Fan Amps	NO.1 _____	NO.2 _____	NO.3 _____
	NO.4 _____	NO.5 _____	NO.6 _____

**TEMPERATURES**

Outdoor-air Temperature	_____ °F DB (Dry Bulb)	_____ °F WB (Wet Bulb)
Return-air Temperature	_____ °F DB	_____ °F WB
Cooling Supply Air Temperature	_____ °F DB	_____ °F WB
Gas Heat Supply Air	_____ °F DB	_____ °F WB

**PRESSURES (HEATING MODE)**

GAS INLET PRESSURE \_\_\_\_\_ IN. WG  
GAS MANIFOLD PRESSURE \_\_\_\_\_ IN. WG (Low Fire) \_\_\_\_\_ IN. WG (High Fire)

**PRESSURES (COOLING MODE)**

REFRIGERANT SUCTION           CIRCUIT 1 \_\_\_\_\_ PSIG           \_\_\_\_\_ °F  
  CIRCUIT 2 \_\_\_\_\_ PSIG           \_\_\_\_\_ °F

REFRIGERANT DISCHARGE       CIRCUIT 1 \_\_\_\_\_ PSIG           \_\_\_\_\_ °F  
  CIRCUIT 2 \_\_\_\_\_ PSIG           \_\_\_\_\_ °F

Verify that 3-phase fan motor and blower are rotating in correct direction (Y/N) \_\_\_\_\_  
Verify that 3-phase scroll compressor is rotating in the correct direction (Y/N) \_\_\_\_\_  
VERIFY REFRIGERANT CHARGE USING CHARGING CHARTS (Y/N) \_\_\_\_\_

**GENERAL**

Economizer minimum vent and changeover settings to job requirements (if equipped) (Y/N) \_\_\_\_\_

CUT ALONG DOTTED LINE

CUT ALONG DOTTED LINE