



# Installation, Start-Up, Service and Controls Operation and Troubleshooting

## CONTENTS

	Page		Page
<b>SAFETY CONSIDERATIONS</b> .....	2	<b>I/O Flex 6126 Controller Specifications, VAV Units Only — 50BVJ,W</b> .....	39
<b>GENERAL</b> .....	2,3	• POWER	
<b>MAJOR SYSTEM COMPONENTS</b> .....	3	• PHYSICAL	
<b>Constant Volume (CV) Units</b> .....	3	• ENVIRONMENTAL OPERATING RANGE	
<b>Variable Air Volume (VAV) Units</b> .....	3	• DIGITAL OUTPUTS	
<b>INSTALLATION</b> .....	3-24	• ANALOG OUTPUTS	
<b>Step 1 — Complete Pre-Installation Checks</b> .....	3	• UNIVERSAL INPUTS	
• EXAMINE THE UNIT		• STANDARD COMMUNICATION PORTS	
• UNIT STORAGE		• RNET PORT	
• MODULAR UNITS		• LOCAL ACCESS PORT	
<b>Step 2 — Rig and Place Unit</b> .....	4	• XNET PORT	
• REMOVE PACKAGING		• BACNET SUPPORT	
• UNIT LOCATION		• STATUS INDICATION	
• UNIT PLACEMENT		• BATTERY	
• ACOUSTICAL CONSIDERATIONS		• PROTECTION	
• ASSEMBLING MODULAR UNITS		• LISTED BY	
<b>Step 3 — Install Ductwork</b> .....	14	• WEIGHT	
• DUCT STATIC PRESSURE PROBE AND TUBING (VAV Only)		• OVERALL DIMENSIONS	
• DUCT HIGH-STATIC (DHS) LIMIT SWITCH (VAV Only)		• MOUNTING HOLE DIMENSIONS	
<b>Step 4 — Make Piping Connections</b> .....	15	<b>Addressing the I/O Flex 6126 Controller</b> .....	39
• CONDENSER WATER PIPING (Water-Cooled Only)		<b>Wiring Inputs and Outputs</b> .....	39
• EVAPORATOR CONDENSATE DRAIN		<b>Input — I/O Flex 6126 Controller</b> .....	40
• HOT WATER HEATING COIL (Optional)		• BINARY OUTPUTS	
• WATERSIDE ECONOMIZER (Optional)		• ANALOG OUTPUTS	
<b>Step 5 — Complete Electrical Connections</b> .....	18	• TO WIRE FIELD ACCESSORIES ON THE I/O FLEX 6126 CONTROLLER OR I/O FLEX EX8160 EXPANDER	
• POWER WIRING		<b>I/O Flex EX8160 Expander Module</b> .....	43
• CONTROL WIRING (CV Only)		• GENERAL DESCRIPTION	
• REMOTE CONDENSER FAN CONTACTOR WIRING		• BACVIEW <sup>6</sup>	
• CONTROL WIRING (VAV Only)		<b>Water to Air Operation, VAV Units Only — 50BVJ,W</b> .....	43
• SUPPLY AIR TEMPERATURE SENSOR (SAT)		<b>Sequence of Operation, VAV Units Only — 50BVJ,W</b> .....	45
• SMOKE DETECTOR/FIRE ALARM SHUTDOWN (FSD)		• CONTROL SOURCE (RUN CONDITIONS)	
• REMOTE OCCUPANCY (ROCC)		• EXTERNAL CONTROL SOURCE	
• RETURN AIR TEMPERATURE SENSOR (RAS)		• DIGITAL INPUT	
<b>START-UP</b> .....	24-35	• BAS	
<b>General</b> .....	24	• MANUAL ON	
• CRANKCASE HEATERS		• INTERNAL CONTROL SOURCE (KEYPAD)	
• CONFIRM THE INPUT POWER PHASE SEQUENCE		<b>Unit Mode</b> .....	45
• INTERNAL WIRING		• COOLING ONLY	
• RETURN-AIR FILTERS		• COOLING ONLY WITH HOT GAS RE-HEAT	
• COMPRESSOR MOUNTING		<b>Fan Modes</b> .....	45
• REFRIGERANT SERVICE PORTS		• START/STOP FANS	
<b>CV Unit Start-Up</b> .....	25	• VARIABLE FREQUENCY DRIVE (VFD) FAN	
• EVAPORATOR FAN		• SUPPLY AND RETURN FAN OPERATION	
• COOLING		• FAN OPERATION DURING DISCHARGE (SUPPLY AIR TEMPERATURE) AIR CONTROL (DAC)	
<b>CONTROLS</b> .....	36-53	• VFD CONTROL	
<b>Unit Protection Module (UPM)</b> .....	36	• FAN OPERATION DURING SMOKE EVENT	
• GENERAL DESCRIPTION		• FAN HISTORY STATISTICS	
• FEATURES AND SAFETIES			
<b>Sequence of Operation, CV Units — 50BVC,Q,T,V</b> .....	38		
• WATER ECONOMIZER COOLING			
• Y CALL (COOLING OR HEATING)			

	Page
<b>Digital Inputs For Monitoring</b> .....	46
• FILTER STATUS (DFS)	
• WATER DIFFERENTIAL PRESSURE SWITCH (DPS)	
• SMOKE DETECTOR STATUS (SDS)	
• COMPRESSOR STATUS	
<b>Cooling Operation</b> .....	46
• COOLING	
• COOLING MODE	
• DISCHARGE AIR CONTROL WITH MODULATING RE-HEAT	
• DISCHARGE AIR TEMPERATURE (DAT) SENSOR	
• HIGH DISCHARGE AIR TEMPERATURE CONDITION (COOLING)	
• HIGH STATIC LOCK	
• WATERSIDE ECONOMIZER MODE	
• LEAVING WATER TEMPERATURE (LWT)	
<b>UPM Fault Monitor</b> .....	52
<b>Troubleshooting</b> .....	52
• COMMUNICATION LEDS	
• COMPLIANCE	
<b>SERVICE</b> .....	53, 54
<b>Compressor Rotation</b> .....	53
<b>Fan Motor Replacement</b> .....	53
<b>MAINTENANCE</b> .....	54-56
<b>Cleaning Unit Exterior</b> .....	54
<b>Coil Cleaning</b> .....	54
<b>Inspection</b> .....	54
<b>Air Filters</b> .....	54
<b>Condensate Drains</b> .....	54
<b>Water-Cooled Condensers</b> .....	54
• GRAVITY FLOW METHOD	
• FORCED CIRCULATION METHOD	
<b>Fan Motor Lubrication</b> .....	55
<b>Fan Bearing Lubrication</b> .....	55
<b>Fan Sheaves</b> .....	55
• ALIGNMENT	
<b>Evaporator Fan Performance Adjustment</b> .....	55
• BELT TENSION ADJUSTMENT	
<b>Compressor Oil</b> .....	56
<b>TROUBLESHOOTING</b> .....	56-58
<b>SCHEMATICS</b> .....	58-63
<b>SENSORS AND INTEGRATION POINTS</b> .....	64-73
<b>START-UP CHECKLIST</b> .....	CL-1, CL-2

## SAFETY CONSIDERATIONS

Installing, starting up, and servicing air-conditioning components and equipment can be dangerous. Only trained, qualified installers and service mechanics should install, start up, and service this equipment.

When working on the equipment, observe precautions in the literature and on tags, stickers, and labels attached to the equipment. Follow all safety codes. Wear safety glasses and work gloves.

### ⚠ WARNING

Before performing service or maintenance operations on unit, turn off main power switch to unit and open all disconnects. More than one disconnect switch may be required to deenergize this equipment. Electric shock hazard can cause injury or death.

### ⚠ CAUTION

Use care in handling, rigging, and setting bulky equipment.

### ⚠ WARNING

DO NOT USE TORCH to remove any component. System contains oil and refrigerant under pressure.

To remove a component, wear protective gloves and goggles and proceed as follows:

- a. Shut off electrical power to unit.
- b. Recover refrigerant to relieve all pressure from system using both high-pressure and low pressure ports.
- c. Traces of vapor should be displaced with nitrogen and the work area should be well ventilated. Refrigerant in contact with an open flame produces toxic gases.
- d. Cut component connection tubing with tubing cutter and remove component from unit. Use a pan to catch any oil that may come out of the lines and as a gage for how much oil to add to the system.
- e. Carefully unsweat remaining tubing stubs when necessary. Oil can ignite when exposed to torch flame.

Failure to follow these procedures may result in personal injury or death.

### ⚠ CAUTION

DO NOT re-use compressor oil or any oil that has been exposed to the atmosphere. Dispose of oil per local codes and regulations. DO NOT leave refrigerant system open to air any longer than the actual time required to service the equipment. Seal circuits being serviced and charge with dry nitrogen to prevent oil contamination when timely repairs cannot be completed. Failure to follow these procedures may result in damage to equipment.

## GENERAL

Omnizone™ 50BV indoor packaged units are very flexible for a variety of applications. These self-contained units are available as water-cooled units. The 50BV units are available with either constant volume (CV) or variable air volume (VAV) controls. In addition, the 50BV unit is available as a water-cooled heat pump. Finally, Omnizone 50BV units are available in two cabinet styles. Unit sizes 020-034 are constructed in a single-piece, unpainted galvanized cabinet. Unit sizes 034-064 are available as modular units, and can be taken apart for easier

installation. Modular units are built using an unpainted, galvanized steel cabinet with steel framework, and can be easily disassembled without breaking the refrigerant lines. See Table 1 for a model number reference by application.

Each unit contains multiple scroll compressors piped in separate refrigerant circuits. Each water-cooled circuit includes a coaxial (tube-in-tube) condenser, TXV (thermostatic expansion valve), individual evaporator coils, and all interconnecting piping. Water-cooled units are shipped fully charged with refrigerant. Remote air-cooled units are shipped with a nitrogen holding charge.

Each unit is equipped with one or two forward-curved centrifugal blowers, to ensure quiet air delivery to the conditioned space. Constant volume units operate at a single, adjustable fan speed and provide zone temperature control using a standard commercial thermostat. For VAV applications, the unit is supplied with a variable frequency drive(s) (VFD) that automatically adjusts blower speed to maintain a constant, adjustable duct static pressure. Compressors are automatically staged to provide supply air temperature control (VAV applications) or zone temperature control using a two-stage commercial thermostat (CV applications).

The 50BV units have removable access panels for easy servicing. These panels allow access to controls, compressors, condensers, VFD(s) (if applicable), evaporator motors, blowers, belts, pulleys, and refrigeration components.

## MAJOR SYSTEM COMPONENTS

### Constant Volume (CV) Units

**MAIN CONTROL BOARD (MCB)** — The main control board for the 50BVC, Q, T, and V units provides both controls and diagnostics including:

- **Condensate Overflow Protection** prevents unit operation in the event that the drain pan clogs.
- **Random Start** provides a programmable start with a range of 30 to 60 seconds.
- **Anti-short Cycle Timer** provides a 5-minute delay to prevent compressor short cycling.
- **Low Pressure Bypass Timer** bypasses the low-pressure switch for 120 seconds to avoid nuisance trips during cold start-up.
- **Brownout/Surge/Power Interruption Protection** will shut down the main control board functions if the secondary voltage falls below 18 volts or goes above 30 volts. A blink code will flash while in fault mode. This will automatically reset when the voltage returns to the valid range.
- **Alarm Output** contacts provide remote fault indication.
- **Test/Service Pin** is a jumper that reduces all time delay settings to 6 seconds during troubleshooting or operation verification.
- **Reset** occurs after a 5-minute delay when a fault condition occurs. When the timer expires, the unit will restart. If the same condition occurs a second time, the unit will be locked out.

- **Lockout Reset** requires that the unit power be cycled at the unit controller via either the thermostat or unit disconnect.

**NOTE:** The refrigerant circuits on dual compressor models are completely independent. If either stage has a fault condition the remaining stage will continue to operate without interruption. A freeze or condensate overflow lockout will shut down both refrigerant circuits.

- **LEDs** are provided for diagnostic purposes.
- **Freeze protection** will shut down the compressor circuit if the refrigerant liquid temperature to the water to refrigerant heat exchanger falls below 26 F for 30 seconds continuous. This trip point can be lowered to 15 F for geothermal applications employing antifreeze by cutting the JP1 and JP2 jumpers on the board.

**Variable Air Volume (VAV) Units** — The 50BVJ and W units come equipped with a Carrier I/O Flex 6126 controller and a VFD.

**NOTE:** The VAV units utilize face split coils and should not be operated below 50% of nominal airflow to prevent coil freezing.

## INSTALLATION

Omnizone™ 50BV units are intended for indoor installation only. Determine building alterations required to run piping, wiring, and ductwork. Read all installation instructions before installing the unit.

### Step 1 — Complete Pre-Installation Checks

**EXAMINE THE UNIT** — Examine the unit for shipping damage. File a claim with the transit company if damage is found. Check the shipment for completeness. Verify that the nameplate electrical requirements match the available power supply.

**UNIT STORAGE** — The 50BV units are designed and packaged for indoor storage and use only. If the equipment is not needed for immediate installation upon its arrival at the job site, it should be left in its shipping carton and stored in a clean, dry area. Units must only be stored or moved in the normal upright position, as indicated by the “UP” arrows on each carton, at all times. **DO NOT STACK UNITS.**

**MODULAR UNITS** — The 50BVT, V, W units are shipped in multiple sections for easy movement and installation. The separate modules of the High Boy units will pass through a standard 36-in. steel framed door or service elevator. The modules of a Low Boy unit will not. Circuit integrity is maintained because none of the refrigerant piping requires disconnection. Water piping connections are made with the use of heavy-duty bronze-bodied unions so no field welding or brazing is required.

**NOTE:** High-boy units ship as two pieces (air-conditioning/filter section and blower section) and can be disassembled into 6 pieces. Low-boy units ship complete and will not fit through a 36 in. door. The low-boy unit’s filter section is integral to unit and cannot be disassembled.

**Table 1 — Model Number Reference By Application Type**

MODEL	TYPE*	AVAILABLE CAPACITY	CONSTRUCTION	CONTROLS
50BVC	Water-Cooled	18 to 30 nominal tons	Single-piece	CV
50BVQ	Water-Cooled Heat Pump	18 to 30 nominal tons	Single-piece	CV
50BVJ	Water-Cooled	18 to 30 nominal tons	Single-piece	VAV
50BVT	Water-Cooled	30 to 60 nominal tons	Modular	CV
50BVV	Water-Cooled Heat Pump	30 to 60 nominal tons	Modular	CV
50BVW	Water-Cooled	30 to 60 nominal tons	Modular	VAV

#### LEGEND

**CV** — Constant Volume  
**VAV** — Variable Air Volume

\*All units are cooling only unless specified.

**Step 2 — Rig and Place Unit** — Use proper lifting and handling practices to avoid damage to the unit. Move modular units with a fork truck using the baserails provided, or use spreader bars and lifting straps as shown in Fig. 1.

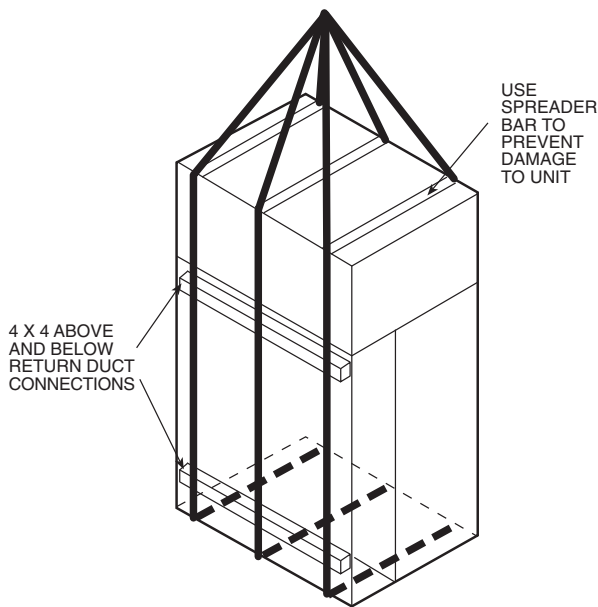

**Fig. 1 — Modular Unit Rigging**

For single piece units, use spreader bars and rigging straps if lifting with a crane to avoid damage to the unit. Otherwise, move with a fork truck using the shipping pallet.

Refer to Fig. 2-8 for unit dimensions.

Refer to Tables 2 and 3 for physical data.

**REMOVE PACKAGING** — Remove all protective plastic; remove and discard unit top cover protector, filter cover, controller display protector, and water piping connection packaging.

**UNIT LOCATION** — Locate the unit in an indoor area that allows easy removal of the filters, access panels, and accessories. Make certain enough space is available for service personnel to perform maintenance or repairs. Provide sufficient room to make all water, duct, and electrical connections. If the unit is located in a small mechanical equipment room, make sure adequate space is available for air to return freely to the unit. These units are not approved for outdoor installations and must be installed inside the structure. Do not locate in areas that are subject to freezing.

**UNIT PLACEMENT** — Ensure that the floor is structurally strong enough to support the weight of the equipment with minimum deflection. A good, level floor is required for proper unit operation and to ensure proper fit-up and alignment of all bolt-together and union-coupled modules on modular units.

**ACOUSTICAL CONSIDERATIONS** — Proper acoustical considerations are a critical part of every system's design and operation. Each system design and installation should be reviewed for its own unique requirements. For job specific requirements, contact an acoustical consultant for guidance and recommendations.

In general, to reduce noise, consider the following:

- Locate mechanical room and ducts away from noise-sensitive locations. Whenever possible, work with the architect to locate the equipment rooms around the perimeters of restrooms, hallways, fire escapes, stair wells, etc., to reduce noise transmission. This allows not only for isolation from radiated sound but also enables the contractor to route duct systems around sensitive locations.

- Construct the equipment room of concrete block or use a double offset stud wall with interwoven insulation. Seal all penetrations.
- Design the system for low total static pressure.
- Use suitable vibration isolation pads or isolation springs according to the design engineer's specifications.
- A flexible canvas duct connector is recommended on both the supply and return air sides of units to be connected to system ductwork.
- Use a minimum of 15 ft of return ductwork between the last air terminal or diffuser and the unit.
- Insulate supply and return ducts with 2-in., 3-lb density insulation.
- Round duct is recommended. If rectangular ductwork is used, keep aspect ratios as small as possible (i.e., as close to square as possible).
- Avoid any direct line of sight from return air grilles into the unit's return. If return air is to be ducted to an equipment room, an elbow should be installed within the equipment room.
- Running a return air drop to near the floor of the room will aid in sound attenuation.
- Do not exceed the recommended supply duct velocity of 2,000 fpm.
- Do not exceed the recommended return duct velocity of 1,000 fpm.
- Use turning vanes on 90-degree elbows.
- Place isolation springs under each corner and under each compressor if utilized.

**ASSEMBLING MODULAR UNITS** — 50BVT,V,W unit sizes 034-064 ship in pieces. Reassemble the unit. Use the loose hardware provided in the main air-conditioning section and the instructions below.

1. The filter/economizer section ships bolted to the main air-conditioning section and can be removed in the field (high-boy unit only). When reattaching the filter/economizer section to the main air-conditioning section, place the filter side of the filter/economizer section facing out and away from the main air-conditioning section.
2. If the unit has 2 filter/economizer and 2 main air-conditioning sections (unit sizes 044-064), bolt the remaining filter/economizer section and main air-conditioning section together, as in Step 1 (high-boy unit only).
3. For units with 2 filter/economizer and 2 main air-conditioning sections, use the provided unions to assemble the water connections between the 2 additional sections joined in Step 2.
4. For units with multiple air-conditioning sections, connect the condensate drain hoses from the "B" side of the unit to the drain manifold on the "A" side of the unit.
5. For unit sizes 044-064, connect power wiring from the main terminal block in the "A" side of the unit to the power terminal block in the "B" side of the unit.
6. For VAV units only, install the duct static pressure sensor 3 to 6 ft downstream in the ductwork from the unit discharge outlet. To avoid improper operation, ensure the sensor is not installed in a place with fully developed air-flow (no turbulence).

**CAUTION**

Remove all shipping blocks, if any, under blower housing or damage to the fan may occur.

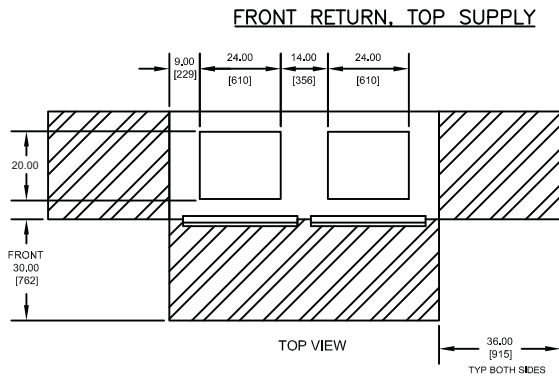

	50BV(C)(Q)(J) UNIT NOMINAL SIZE			
	020	024	028	034
<b>A</b>	14.75 [375]	14.75 [375]	14.75 [375]	18.88 [479]
<b>B</b>	8.50 [216]	8.50 [216]	8.50 [216]	8.75 [222]
<b>C</b>	2.75 [70]	2.75 [70]	2.75 [70]	2.75 [70]
<b>D</b>	40.00 [1016]	40.00 [1016]	40.00 [1016]	61.00 [1549]
<b>E</b>	20.00 [508]	20.00 [508]	20.00 [508]	30.00 [762]
<b>F</b>	38.00 [965]	38.00 [965]	38.00 [965]	58.00 [1473]
<b>G</b>	62.00 [1575]	62.00 [1575]	62.00 [1575]	86.50 [2197]
<b>H</b>	4.00 [101]	4.00 [101]	4.00 [101]	4.00 [101]
<b>J</b>	18.75 [476]	18.75 [476]	18.75 [476]	18.75 [476]
<b>K</b>	3.25 [83]	3.25 [83]	3.25 [83]	3.50 [89]
<b>L</b>	33.00 [838]	33.00 [838]	33.00 [838]	32.00 [813]
<b>WATER CONN.</b>	2" FPT	2" FPT	2" FPT	2" FPT
<b>CONDENSATE CONN.</b>	1-1/4" FPT	1-1/4" FPT	1-1/4" FPT	1-1/4" FPT
<b>FILTER QTY &amp; SIZE</b>	(4) 20 x 34-1/2 x 1"	(4) 20 x 34-1/2 x 1"	(4) 20 x 34-1/2 x 1"	(4) 30 x 34-1/2 x 1"

- NOTES:
1. Dimensions in inches [mm].
  2. 50BVJ units are rear return, top supply only.
  3. Compressor, controls, and condenser access are through front panels.
  4. Field power connections are 1 3/4 inches. Control connections are 7/8 inches.
  5. Optional blower orientation is selected in model number nomenclature as option 9 in FIOP section (digits 15 and 16).

Shows recommended minimum service clearances.

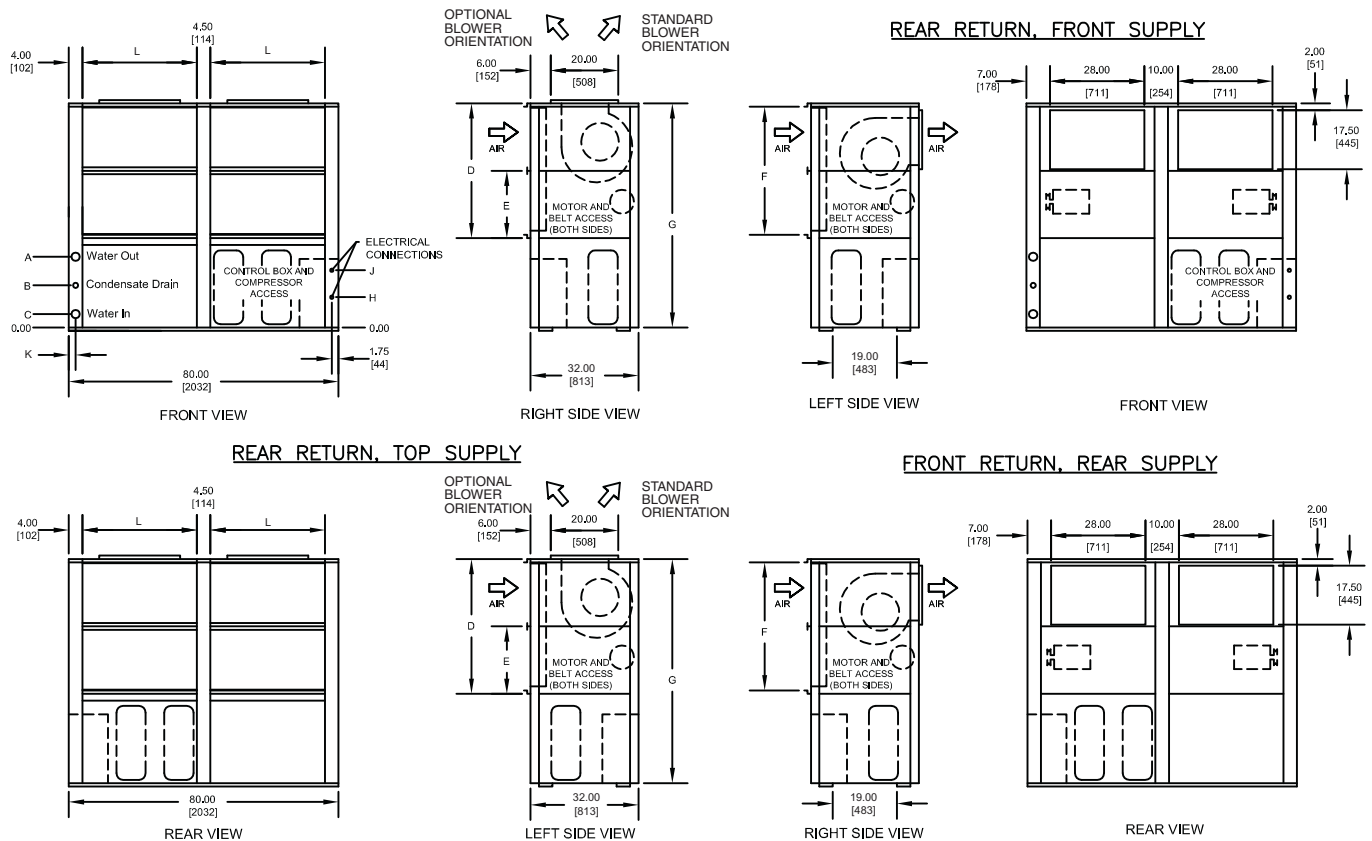

\*For further detailed drawings, please consult the latest version of SCUBuilder.

**Fig. 2 — 50BVC,J,Q020-034 Dimensions (Without Waterside Economizer or Hot Water Coil)\***

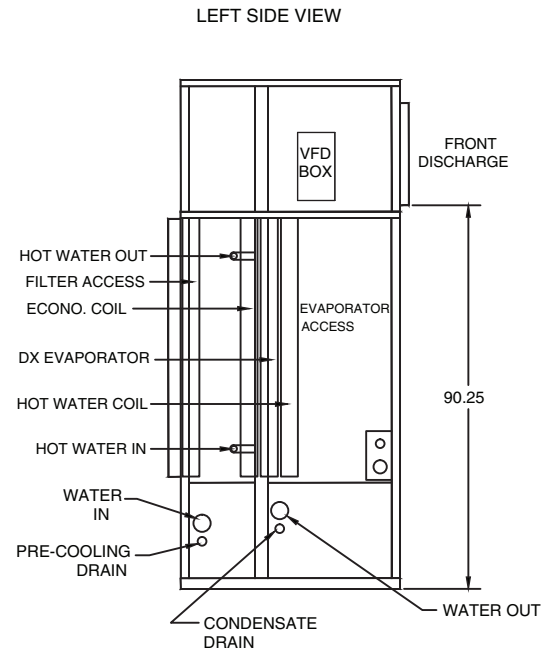
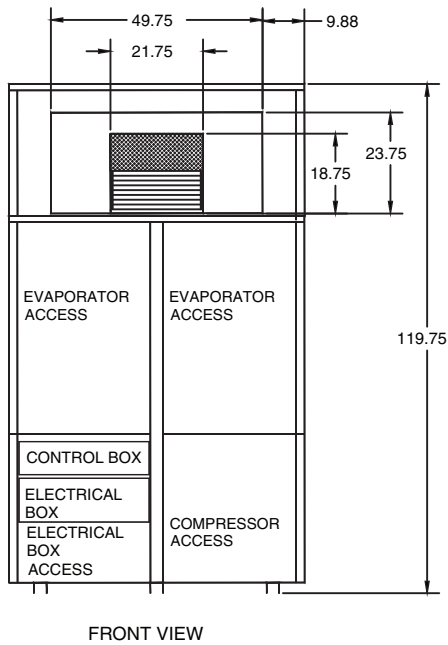
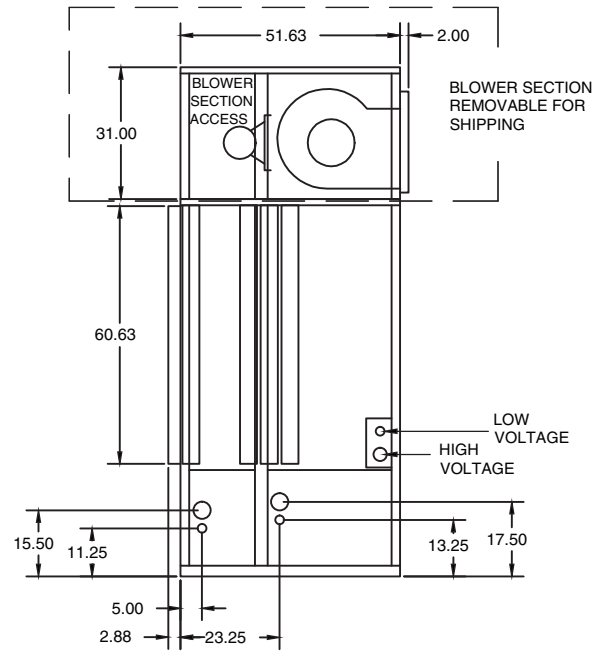
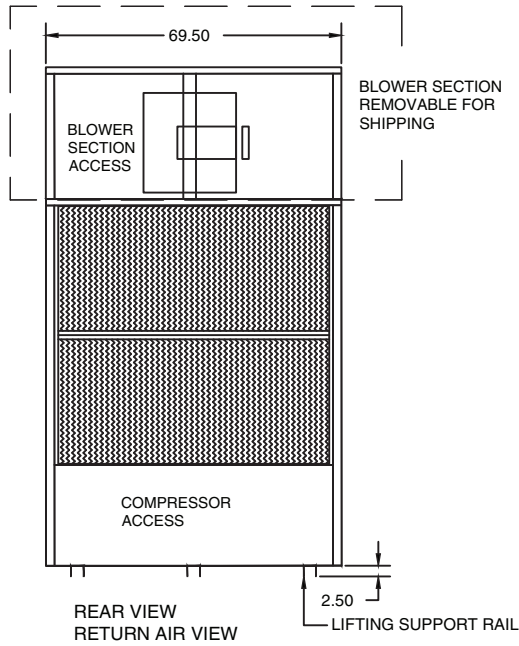

FILTERS		
NOMINAL	ACTUAL	QUANTITY
17 X 30	16.5 X 29.75	8

\*\*4 INCHES THICK

WATER CONNECTIONS	
H2O IN*	2.5
H2O OUT*	2.5
CONDENSATE*	1.25
PRE-COOLING DRAIN*	1.25
HW IN/OUT (SWEAT)	1.38

\*F.P.T. TYPE CONNECTION

**NOTES:**

- Dimensions in inches.
- All units are rear return airflow configuration.
- Constant volume units are available with front or rear air supply.
- VAV units (50BVW) are available with rear supply only.
- Recommended minimum service clearances are as follows:
  - Front and rear — 30 in. (762 mm)
  - Left or right side — 65 in. (1651 mm) for coil removal
  - Side opposite coil removal — 20 in. (508 mm)
- Optional hot water coil connections may add up to 3 in. on both the left and right side of the unit, increasing the unit width by 6 inches.

**CONNECTIONS**

LETTER	CONNECTION	SIZE
A	WATER OUT	2-1/2 IN. FPT
B	WATER IN	2-1/2 IN. FPT
C	CONDENSATE DRAIN	1-1/4 IN. FPT
D	ECONOMIZER (PRE-COOLING) DRAIN	1-1/4 IN. FPT

REPLACEMENT FILTERS : EIGHT (8) AT 17 x 27 x 4 INCHES.

**Fig. 3 — 50BTV,V,W034 (High-Boy) Dimensions**

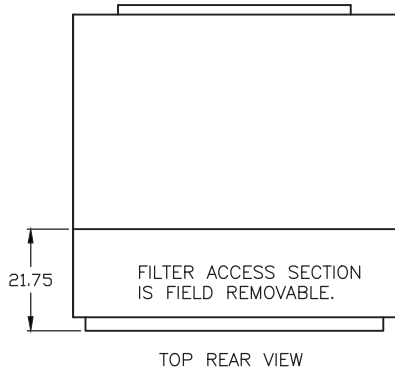
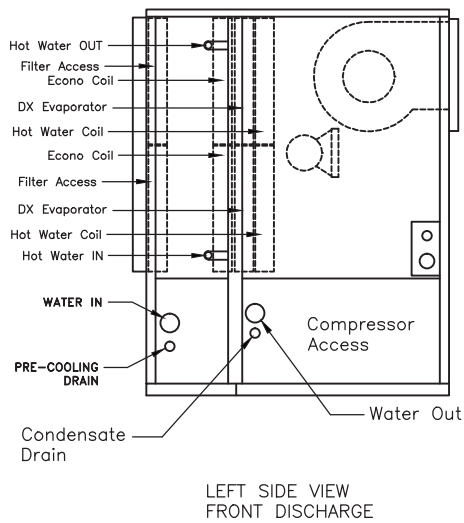
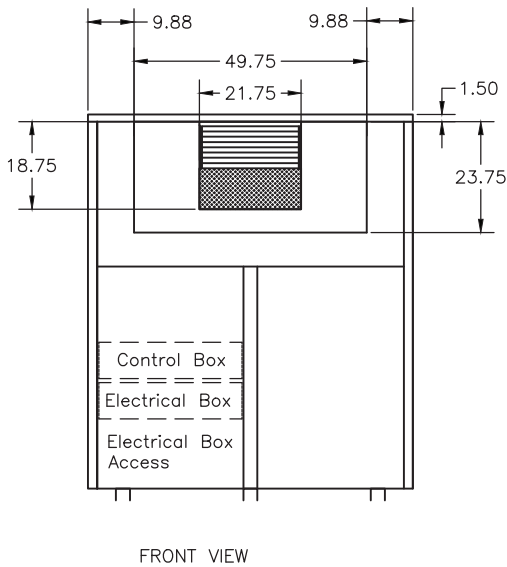
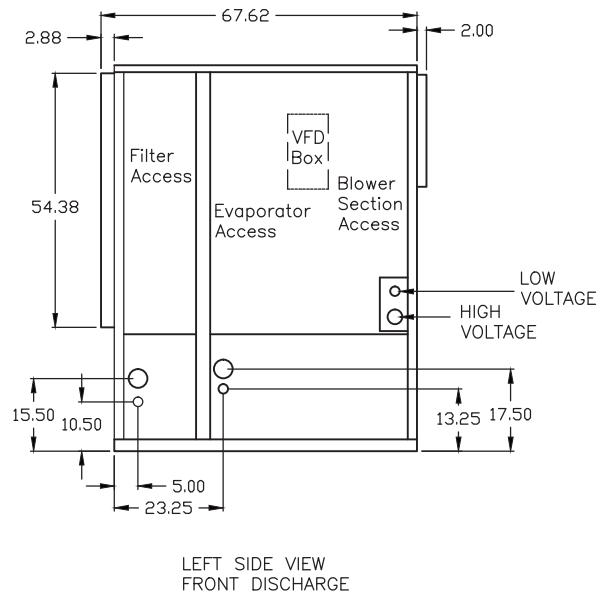
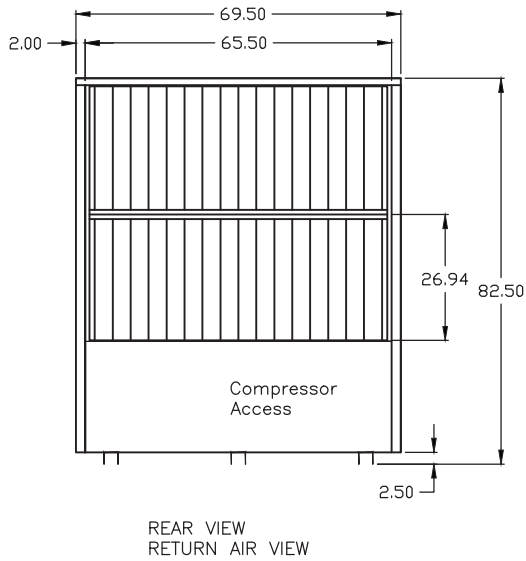

FILTERS			**4 INCHES THICK
NOMINAL	ACTUAL	QUANTITY	
17 X 27	16.5 X 26.50	8	

WATER CONNECTIONS		*F.P.T. Type Connection
H2O IN*	2.5	
H2O OUT*	2.5	
CONDENSATE*	1.25	
PRE-COOLING DRAIN*	1.25	
HW IN/OUT (SWEAT)	1.38	

- NOTES:
- Dimensions in inches.
  - All units are rear return airflow configuration.
  - Recommended minimum service clearances are as follows:
    - Front and rear — 30 in. (762 mm)
    - Left or right side — 65 in. (1651 mm) for coil removal
    - Side opposite coil removal — 20 in. (508 mm)
  - Optional hot water coil connections may add up to 3 in. on both the left and right side of the unit, increasing the unit width by 6 inches.

CONNECTIONS		
A	WATER OUT	2-1/2 IN. FPT
B	WATER IN	2-1/2 IN. FPT
C	CONDENSATE DRAIN	1-1/4 IN. FPT
D	ECONOMIZER (PRE-COOLING) DRAIN	1-1/4 IN. FPT

REPLACEMENT FILTERS : EIGHT (8) AT 17 x 27 x 4 INCHES.

Fig. 4 — 50BVT,V,W034 (Low-Boy) Dimensions

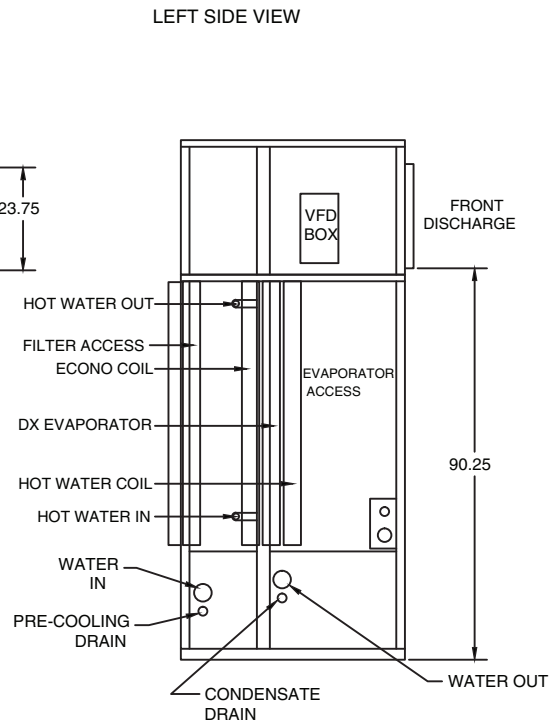
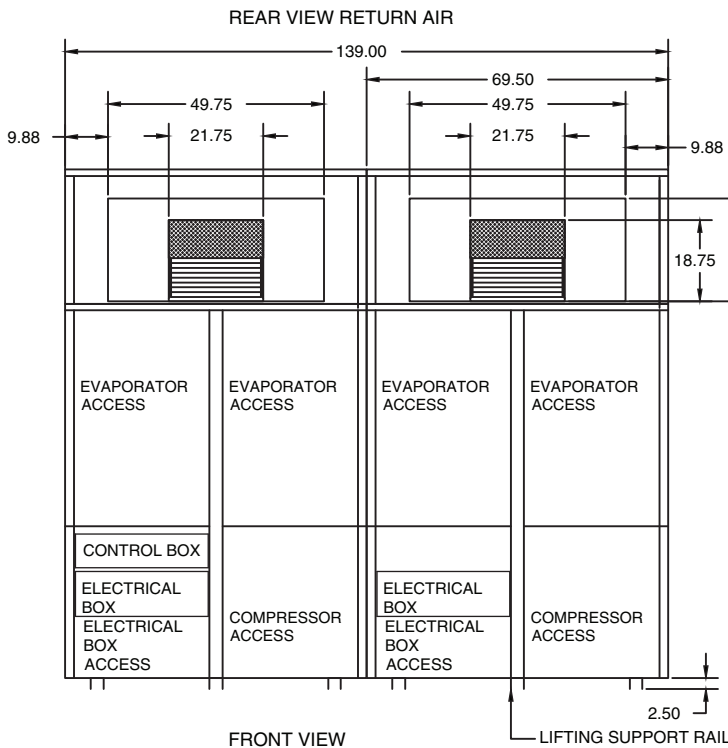
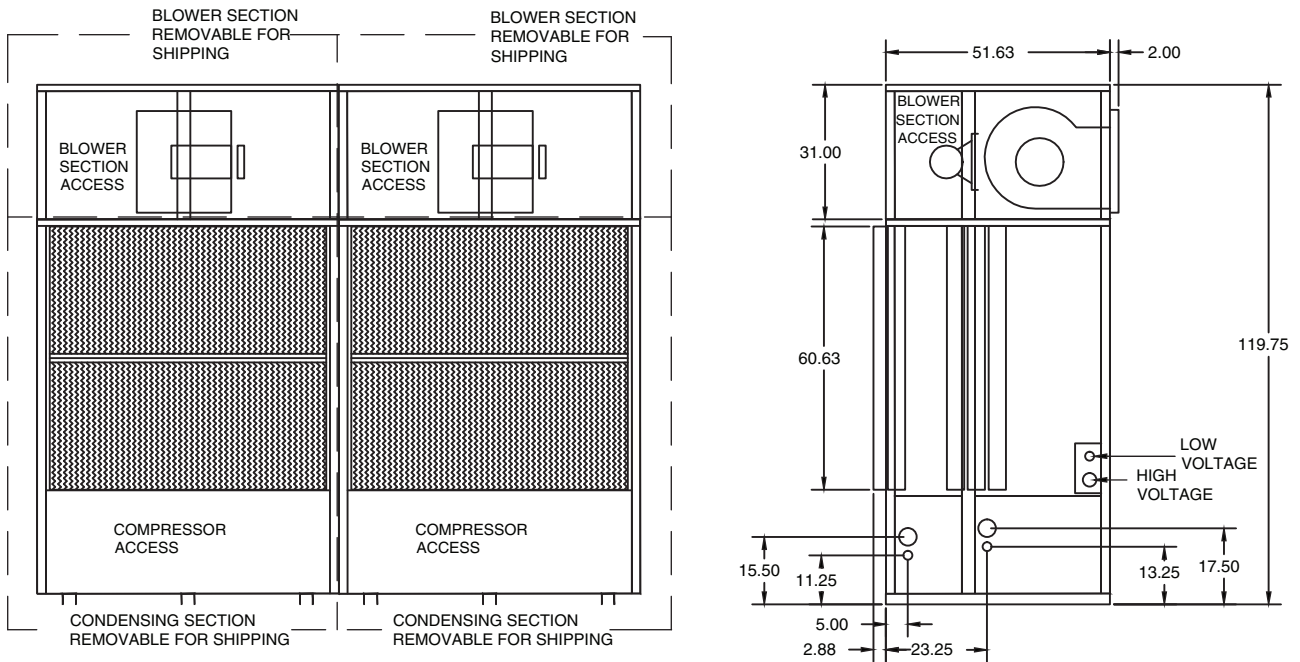

FILTERS		
NOMINAL	ACTUAL	QUANTITY
17 X 30 X 4	16.5 X 29.75 X 4	16

WATER CONNECTIONS			
Model	44	54	64
H2O IN*	2.5	3.0	3.0
H2O OUT*	2.5	3.0	3.0
Condensate*	1.25	1.25	1.25
Pre-Cooling Drain*	1.25	1.25	1.25
HW IN/OUT (Sweat)	1.38	1.38	1.38

\*F.P.T. Type Connection

NOTE: Optional hot water coil connections may add up to 3 in. on both the left and right side of the unit, increasing the unit width by 6 inches.

**Fig. 5 — 50BVT,V,W044-064 (High-Boy) Dimensions**



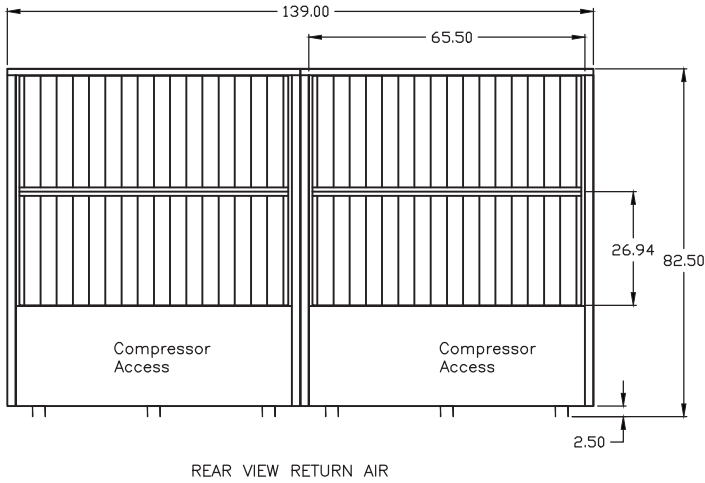

REAR VIEW RETURN AIR

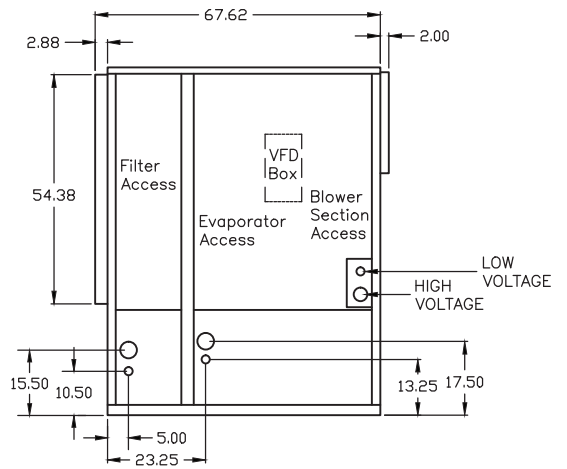

LEFT SIDE VIEW TOP DISCHARGE

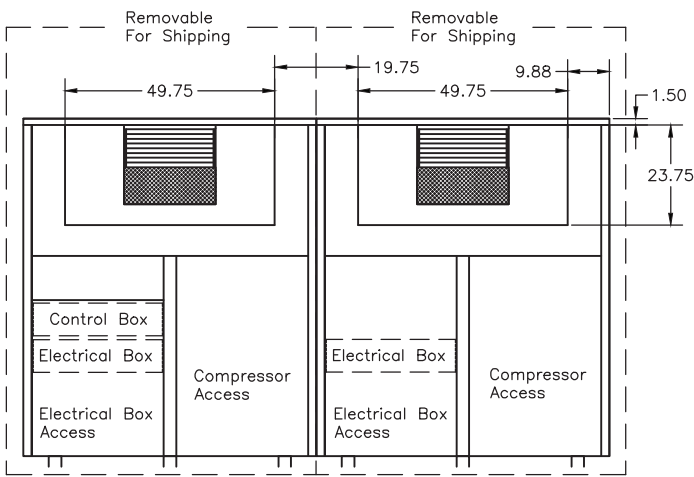

FRONT VIEW

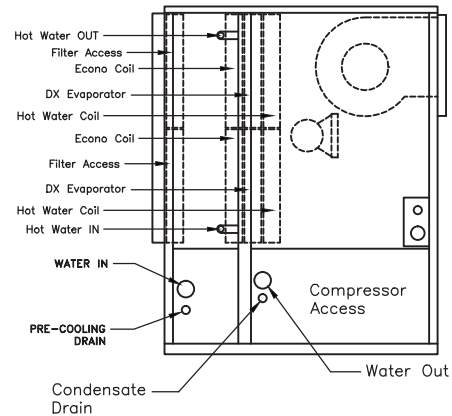

LEFT SIDE VIEW TOP DISCHARGE

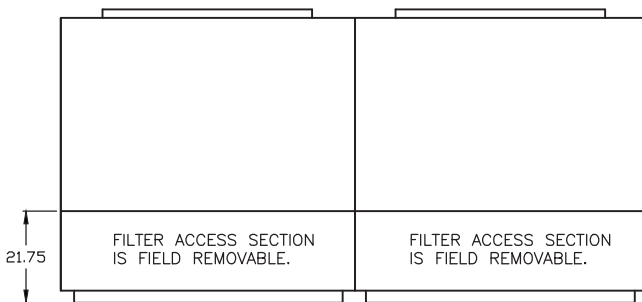

TOP VIEW

FILTERS		
NOMINAL	ACTUAL	QUANTITY
17 X 30 X 4	16.5 X 29.75 X 4	16

WATER CONNECTIONS			
Model	44	54	64
H2O IN*	2.5	3.0	3.0
H2O OUT*	2.5	3.0	3.0
Condensate*	1.25	1.25	1.25
Pre-Cooling Drain*	1.25	1.25	1.25
HW IN/OUT (Sweat)	1.38	1.38	1.38

\*F.P.T. Type Connection

CONNECTIONS

UNIT SIZE		044	054	064
A	WATER OUT	2-1/2 IN. FPT	3 IN. FPT	3 IN. FPT
B	WATER IN	2-1/2 IN. FPT	3 IN. FPT	3 IN. FPT
C	CONDENSATE DRAIN	1-1/4 IN. FPT	1-1/4 IN. FPT	1-1/4 IN. FPT
D	ECONOMIZER (PRE-COOLING) DRAIN	1-1/4 IN. FPT	1-1/4 IN. FPT	1-1/4 IN. FPT

REPLACEMENT FILTERS : SIXTEEN (16) AT 17 x 27 x 4 INCHES.

NOTES:

- Dimensions in inches.
- All units are rear return airflow configuration.
- Recommended minimum service clearances are as follows:
  - Front and rear — 30 in. (762 mm)
  - Left and right sides — 65 in. (1651 mm) for coil removal
- Optional hot water coil connections may add up to 3 in. on both the left and right side of the unit, increasing the unit width by 6 inches.

Fig. 6 — 50BVT,V,W044-064 (Low-Boy) Dimensions

**Table 2 — Physical Data — 50BVC,J,Q**

UNIT 50BVC,J,Q	020	024	028	034
<b>NOMINAL CAPACITY (Tons)</b>	18	20	25	30
<b>OPERATING WEIGHT (lb) 50BVC,Q...50BVJ</b>	1192...1227	1378...1413	1428...1473	1680...1725
<b>COMPRESSOR</b>	Copeland Scroll			
Quantity	2	2	2	2
Number of Refrigerant Circuits	2	2	2	2
Oil (oz) Ckt 1...Ckt 2	85...85	110...110	110...110	140...140
<b>REFRIGERANT TYPE</b>	R-410A			
Expansion Device	TXV	TXV	TXV	TXV
Operating Charge (oz) per Ckt	130	145	145	288
<b>CONDENSER (50BVC,Q,J only)</b>	Tube-in-Tube Coaxial			
Quantity of Manifolder Circuits	2	2	2	2
Nominal Flow Rate (gpm)	54	60	75	90
Water Flow Range (gpm)	36-72	40-80	50-100	60-120
Max Water Working Pressure (psig)	400	400	400	400
Max Refrig. Working Pressure (psig)	450	450	450	450
Min Entering Water Temp (F)	50	50	50	50
Max Entering Water Temp (F)	110	110	110	110
Waterside Volume (gal)	3.6	4.0	5.0	6.0
<b>EVAPORATOR COIL</b>				
Rows...Fins/in.	3...14	3...14	3...14	3...14
Total Face Area (sq ft)	18.1	18.1	18.1	22.0
<b>EVAPORATOR FAN</b>				
Quantity...Size	2...15x15	2...15x15	2...15x15	2...15x15
Type Drive	Belt	Belt	Belt	Belt
Nominal cfm	7200	8000	10,000	12,000
Std Motor Qty...hp...Frame Size	2...1.5...56	2...2...56H	2...3...56HZ	2...5...56HZ
Alt 1 Motor Qty...hp...Frame Size	2...2...56H	2...3...56HZ	2...5...56HZ	—
Alt 2 Motor Qty...hp...Frame Size	2...3...56HZ	2...5...56HZ	—	—
Alt 3 Motor Qty...hp...Frame Size	2...5...56HZ	—	—	—
Motor Nominal rpm (1.5, 2, 3, hp)	1725	1725	1725	—
Motor Nominal rpm (5 hp)	3450	3450	3450	3450
Fan Drive rpm Range				
Std Fan Drive (1.5, 2, 3 hp)	753-952	753-952	753-952	—
Std Fan Drive (5 hp)	967-1290	967-1290	967-1290	967-1290
Med Static Fan Drive (1.5, 2, 3 hp)	872-1071	872-1071	872-1071	—
Motor Bearing Type	Ball	Ball	Ball	Ball
Maximum Allowable rpm	1300	1300	1300	1300
Motor Pulley Pitch Diameter				
Std Fan Drive (1.5, 2, 3 hp)	3.7-4.7	3.7-4.7	3.7-4.7	—
Std Fan Drive (5 hp)	2.9-3.9	2.9-3.9	2.9-3.9	2.9-3.9
Med Static Fan Drive (1.5, 2, 3 hp)	4.3-5.3	4.3-5.3	4.3-5.3	—
Motor Shaft Diameter (in.) (1.5, 2 hp)	<sup>5</sup> / <sub>8</sub>	<sup>5</sup> / <sub>8</sub>	—	—
Motor Shaft Diameter (in.) (3, 5 hp)	<sup>7</sup> / <sub>8</sub>	<sup>7</sup> / <sub>8</sub>	<sup>7</sup> / <sub>8</sub>	<sup>7</sup> / <sub>8</sub>
Belt, Qty...Type...Length (in.)				
Std Fan Drive (1.5, 2 hp)	1...B...39	1...B...39	—	—
Std Fan Drive (3 hp)	2...B...39	2...B...39	2...B...39	—
Std Fan Drive (5 hp)	2...BX...42	2...BX...42	2...BX...42	2...BX...42
Med Static Fan Drive (1.5, 2 hp)	1...B...40	1...B...40	—	—
Med Static Fan Drive (3 hp)	2...B...40	2...B...40	2...B...40	—
Pulley Center Line Distance (in.)	10.1-10.9	10.1-10.9	10.1-10.9	10.1-10.9
Speed Change Per Full Turn of Moveable Pulley Flange (rpm)				
Std Fan Drive (1.5, 2, 3 hp)	33	33	33	—
Std Fan Drive (5 hp)	54	54	54	54
Med Static Fan Drive (1.5, 2, 3 hp)	33	33	33	—
Fan Shaft Diameter (in.)	1	1	1	1
<b>HIGH PRESSURE SWITCHES (psig)</b>				
Cutout	600 ± 10	600 ± 10	600 ± 10	600 ± 10
Reset (Auto)	500 ± 10	500 ± 10	500 ± 10	500 ± 10
<b>LOW PRESSURE SWITCHES (psig)</b>				
Cutout	40 ± 3	40 ± 3	40 ± 3	40 ± 3
Reset (Auto)	60 ± 5	60 ± 5	60 ± 5	60 ± 5
<b>RETURN AIR FILTERS</b>				
Quantity...Size (in.)	4...20x34.5x1	4...20x34.5x1	4...20x34.5x1	4...30x34.5x1

**LEGEND**

TXV — Thermostatic Expansion Valve

**Table 3 — Physical Data — 50BVT,V,W**

UNIT 50BVT,V,W,X	034	044	054	064
<b>NOMINAL CAPACITY (Tons)</b>	30	40	50	60
<b>OPERATING WEIGHT (lb) 50BVT,V...50BVW</b>	2580...2645	4334...4404	5198...5298	5230...5330
<b>COMPRESSOR</b>	Copeland Scroll			
Quantity	2	4	4	4
Number of Refrigerant Circuits	2	4	4	4
Oil (oz)				
Circuit 1...Circuit 2	140...140	110...110	140...140	140...140
Circuit 3...Circuit 4	—	110...110	140...140	140...140
<b>REFRIGERANT TYPE</b>	R-410A			
Expansion Device	TXV	TXV	TXV	TXV
Operating Charge (oz per Ckt)	288	160	288	288
<b>CONDENSER (50BVT,V,W only)</b>	Tube-in-Tube Coaxial			
Quantity of Manifolder Circuits	2	4	4	4
Nominal Flow Rate (gpm)	90	120	150	180
Water Flow Range (gpm)	60-120	80-160	100-200	120-240
Max Water Working Pressure (psig)	400	400	400	400
Max Refrig. Working Pressure (psig)	450	450	450	450
Min Entering Water Temp (F)	50	50	50	50
Max Entering Water Temp (F)	110	110	110	110
Waterside Volume (gal)	6.0	9.0	11.3	13.5
<b>EVAPORATOR COIL</b>				
Rows...Fins/in.	4...12	3...12	4...12	4...12
Total Face Area (sq ft)	23.2	46.4	46.4	46.4
<b>EVAPORATOR FAN</b>				
Quantity...Size	1...18x18	2...18x18	2...18x18	2...18x18
Type Drive	Belt	Belt	Belt	Belt
Nominal cfm	12,000	16,000	20,000	24,000
Motor Option 1 Qty...hp...Frame Size	1...7.5...213T	2...7.5...213T	2...7.5...213T	2...7.5...213T
Motor Option 2 Qty...hp...Frame Size	1...10...215T	2...10...215T	2...10...215T	2...10...215T
Motor Option 3 Qty...hp...Frame Size	1...15...254T	2...15...254T	2...15...254T	2...15...254T
Motor Option 4 Qty...hp...Frame Size	1...20...256T	—	2...20...256T	2...20...256T
Motor Nominal rpm	1750	1750	1750	1750
Fan Drive RPM Range				
Standard (7.5 hp)	780-960	780-960	780-960	780-960
Standard (10, 15, 20 hp), Med Static (7.5 hp)	805-991	805-991	805-991	805-991
Med Static (10, 15, 20 hp), High Static (7.5 hp)	960-1146	960-1146	960-1146	960-1146
High Static (10, 15, 20 hp)	1119-1335	1119-1335	1119-1335	1119-1335
Motor Bearing Type	Ball	Ball	Ball	Ball
Maximum Allowable rpm	1450	1450	1450	1450
Motor Pulley Pitch Diameter				
Std Fan Drive (7.5 hp)	5.2-6.4	5.2-6.4	5.2-6.4	5.2-6.4
Std Fan Drive (10, 15, 20 hp), Med Static (7.5 hp)	4.8-6.0	4.8-6.0	4.8-6.0	4.8-6.0
Med Static Fan Drive (10, 15, 20 hp), High Static (7.5 hp)	5.8-7.0	5.8-7.0	5.8-7.0	5.8-7.0
High Static Fan Drive (10, 15, 20 hp)	5.8-7.0	5.8-7.0	5.8-7.0	5.8-7.0
Motor Shaft Diameter (in.) (7.5, 10 hp)	1 <sup>3</sup> / <sub>8</sub>	1 <sup>3</sup> / <sub>8</sub>	1 <sup>3</sup> / <sub>8</sub>	1 <sup>3</sup> / <sub>8</sub>
Motor Shaft Diameter (in.) (15, 20 hp)	1 <sup>5</sup> / <sub>8</sub>	1 <sup>5</sup> / <sub>8</sub>	1 <sup>5</sup> / <sub>8</sub>	1 <sup>5</sup> / <sub>8</sub>
Belt, Qty...Type...Length (in.)				
Std Fan Drive (7.5 hp)	2...B...48	2...B...48	2...B...48	2...B...48
Std Fan Drive (10, 15, 20 hp), Med Static (7.5 hp)	2...B...46	2...B...46	2...B...46	2...B...46
Med Static Fan Drive (10, 15, 20 hp), (High Static 7.5 hp)	2...B...48	2...B...48	2...B...48	2...B...48
High Static Fan Drive (10, 15, 20 hp)	2...B...45	2...B...45	2...B...45	2...B...45
Pulley Center Line Distance (in.)	10.2-11.4	10.2-11.4	10.2-11.4	10.2-11.4
Speed Change Per Full Turn of Moveable Pulley Flange (rpm)				
Std Fan Drive (7.5 hp)	36	36	36	36
Std Fan Drive (10, 15, 20 hp), Med Static (7.5 hp)	31	31	31	31
Med Static Fan Drive (10, 15, 20 hp), High Static (7.5 hp)	31	31	31	31
High Static Fan Drive (10, 15, 20 hp)	36	36	36	36
Fan Shaft Diameter (in.)	1 <sup>7</sup> / <sub>16</sub>	1 <sup>7</sup> / <sub>16</sub>	1 <sup>7</sup> / <sub>16</sub>	1 <sup>7</sup> / <sub>16</sub>
<b>HIGH PRESSURE SWITCHES (psig)</b>				
Cutout	600 ± 10	600 ± 10	600 ± 10	600 ± 10
Reset (Auto)	500 ± 10	500 ± 10	500 ± 10	500 ± 10
<b>LOW PRESSURE SWITCHES (psig)</b>				
Cutout	40 ± 3	40 ± 3	40 ± 3	40 ± 3
Reset (Auto)	60 ± 5	60 ± 5	60 ± 5	60 ± 5
<b>RETURN AIR FILTERS</b>				
Quantity...Size (in.)	8...17x27x4	16...17x27x4	16...17x27x4	16...17x27x4

**LEGEND**

TXV — Thermostatic Expansion Valve

**FRONT RETURN, TOP SUPPLY  
SHOWN**

**50BV(C)(Q)(J) UNIT NOMINAL SIZE**

	020	024	028
A	28.00 [711]	32.00 [813]	32.00 [813]
B	31.00 [787.4]	35.00 [889]	35.00 [889]
C	17.50 [445]	18.75 [476]	18.75 [476]
D	62.00 [1575]	66.50 [1689]	66.50 [1689]
WATER CONN.	2" FPT	2" FPT	2" FPT
CONDENSATE CONN.	1-1/4" FPT	1-1/4" FPT	1-1/4" FPT
FILTER QTY. & SIZE	(4) 17 x 34-1/2 x 1"	(4) 17x 34-1/2 x 1"	(4) 17x 34-1/2 x 1"

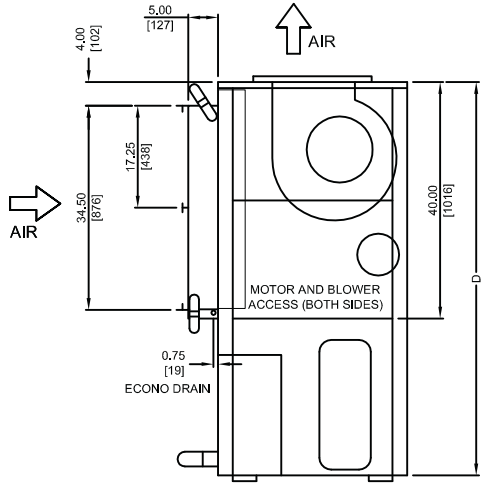

**RIGHT SIDE VIEW**

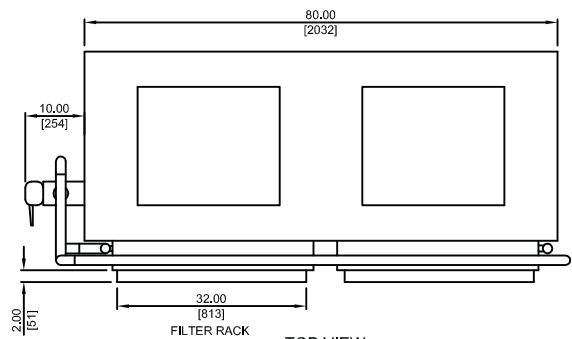

**TOP VIEW**

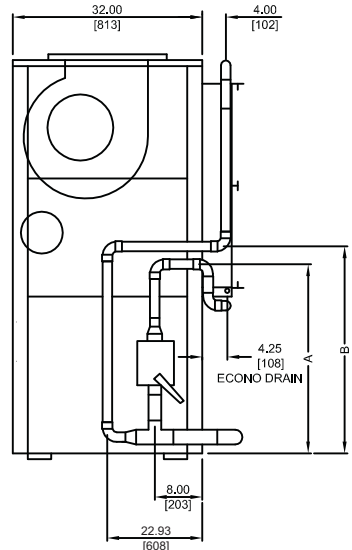

**LEFT SIDE VIEW**

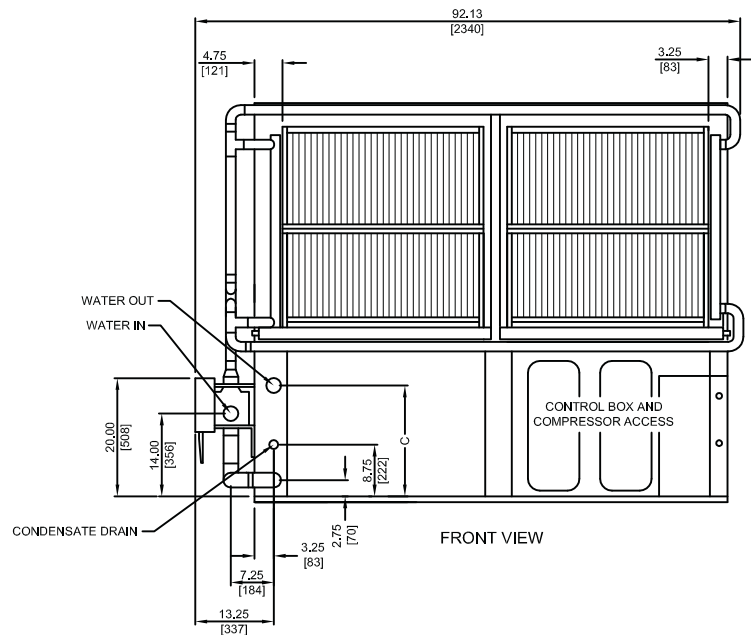

**FRONT VIEW**

- NOTES:**
1. Dimensions in inches [mm].
  2. Refer to base unit certified drawing for additional unit dimensions, service clearance, and alternate airflow configurations.

**Fig. 7 — 50BVC,J,Q020-028 with Optional Waterside Economizer Dimensions**

**FRONT RETURN, TOP SUPPLY  
SHOWN**

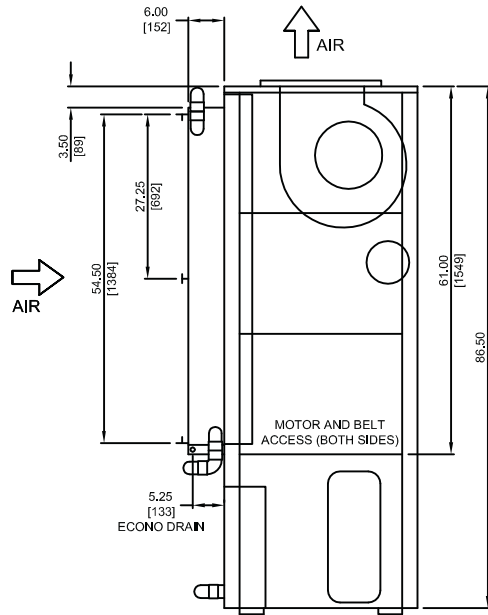

RIGHT SIDE VIEW

50BV(C)(Q)(J) 034	
DESCRIPTION	SIZE
WATER CONN.	2" FPT
CONDENSATE CONN.	1-1/4" FPT
FILTER QTY. & SIZE	(4) 27" x 34-1/2" x 1"

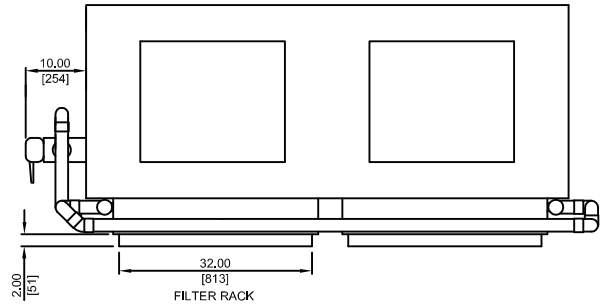

TOP VIEW

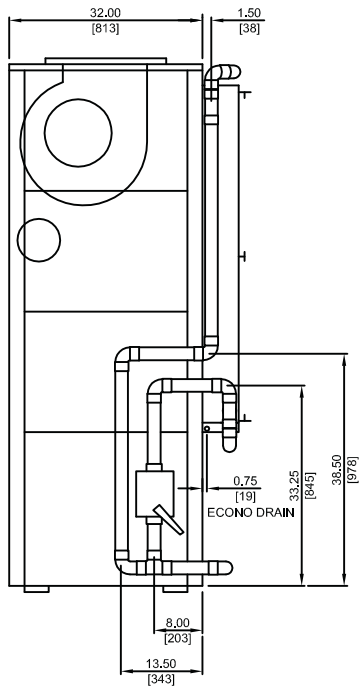

LEFT SIDE VIEW

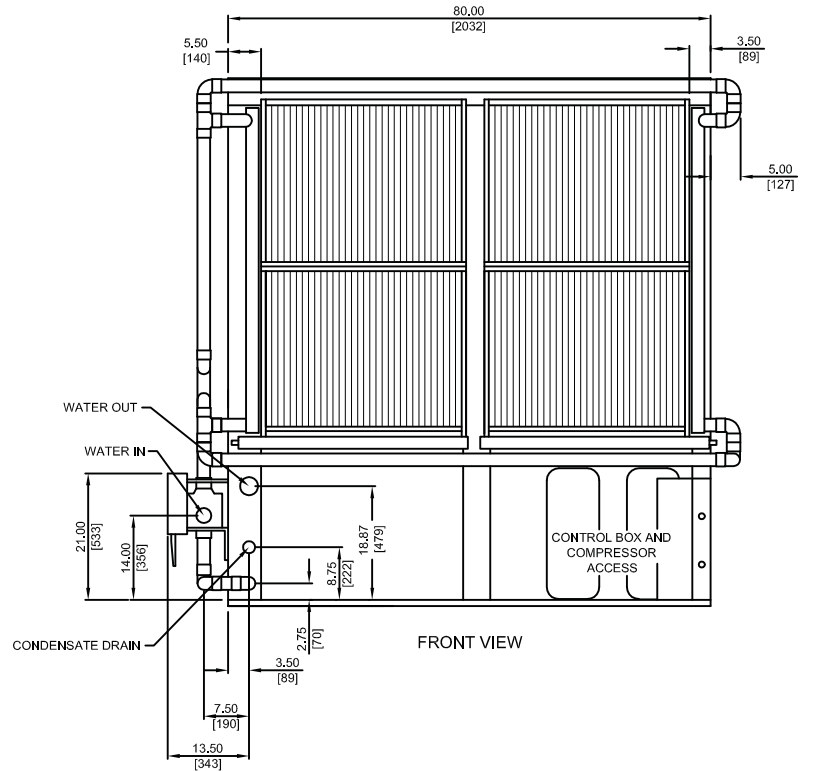

FRONT VIEW

**NOTES:**

1. Dimensions in inches [mm].
2. Refer to base unit certified drawing for additional unit dimensions, service clearances, and alternate airflow configurations.

**Fig. 8 — 50BVC,J,Q034 with Optional Waterside Economizer Dimensions**

**Step 3 — Install Ductwork** — The VAV units must use a “pair of pants” configuration as shown in Fig. 9. Refer to the Carrier System Design Manual or ASHRAE (American Society of Heating, Refrigerating and Air-Conditioning Engineers) standards for the recommended duct connection to unit with 2 fans.

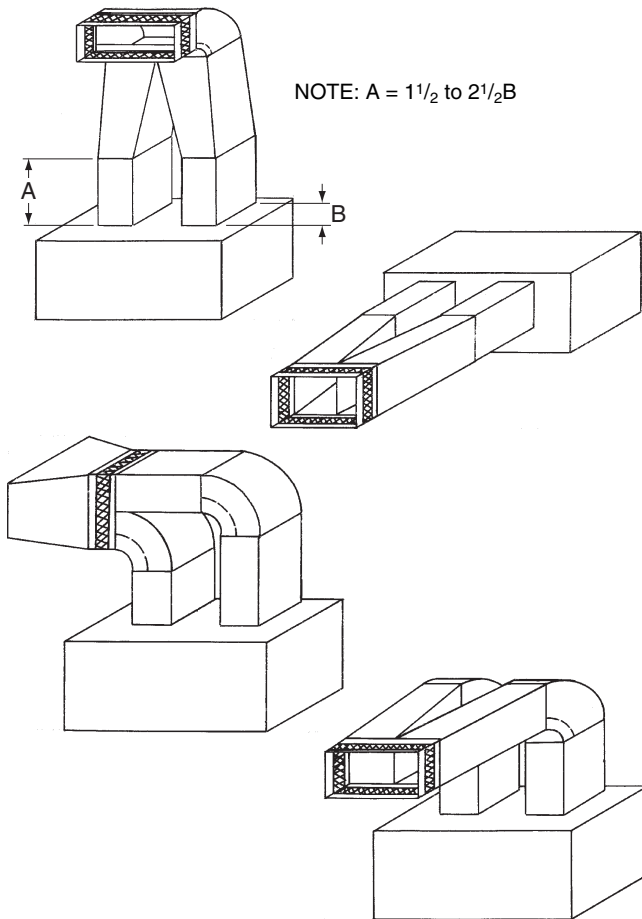

**Fig. 9 — Typical Fan Discharge Connections for Multiple Fan Units**

A supply air outlet collar and return air duct flange are provided on all units to facilitate duct connections. Refer to dimensional drawings (Fig. 2-8) for connection sizes and locations.

A flexible canvas duct connector is recommended on both supply and return air sides of the units to be connected to the system ductwork.

All metal ductwork should be adequately insulated to avoid heat loss or gain and to prevent condensation from forming on the duct walls. Uninsulated ductwork is not recommended, as the unit’s performance will be adversely affected.

Do not connect discharge ducts directly to the blower outlet(s). The factory filter should be left in place on a free return system.

If the unit will be installed in a new installation, the duct system should be designed in accordance with the System Design Manual, Part 2 and with ASHRAE (American Society of Heating, Refrigeration and Air-Conditioning Engineers) procedures for duct sizing. If the unit will be connected to an existing duct system, check that the existing duct system has the capacity to handle the required airflow for the unit application at an acceptable system static pressure. If the existing duct system is too small, larger ductwork must be installed.

The duct system and diffusers should be sized to handle the design airflow volumes quietly. To maximize sound attenuation

of the unit’s blower(s), the supply and return air plenums should be insulated for a length of at least 15 ft from the unit. Direct line of sight from return air grilles into the unit’s return should be avoided. If return air is to be ducted to an equipment room, an elbow should be installed within the equipment room. Running a return air drop to near the floor of the room will aid in sound attenuation. Avoid transmitting vibrations generated by the movement of air in the ducting to the walls of the building. This is especially important where ductwork penetrates walls. The maximum recommended return air velocity is 1,000 fpm. Lower return air velocities will result in lower sound power levels. The use of round supply duct plenums should be considered, as it will significantly reduce low frequency sound at the equipment room. If rectangular supply plenums are used, the aspect ratio of the duct should be kept as small as possible (i.e., as close to square as possible). The large, flat surface areas associated with large aspect ratio duct systems will transmit sound to the space, and the potential for duct-generated noise is increased. The maximum recommended supply air duct velocity is 2,000 fpm.

Units with two fans should have a properly designed “pair of pants” duct connection. An adequate straight length of ducting from the unit should be allowed before elbows are installed. If connecting an elbow directly to the fan outlet, a minimum straight length of 2 fan diameters from the fan outlet is recommended. Elbows should turn in the direction of fan rotation, if possible. Abrupt turns will generate air turbulence and excessive noise. Turning vanes should be used in all short radius bends. Ensure that ducting does not obstruct access to the unit for routine servicing.

**DUCT STATIC PRESSURE PROBE AND TUBING (VAV ONLY)** — On VAV systems, the duct static pressure sensor and tubing are field-mounted. The sensor tubing sensing point should be located near the end of the main supply trunk duct in a position free from turbulence effects and at least 10 duct diameters downstream and 4 duct diameters upstream from any major transitions or branch take-offs. Incorrectly placing the sensing point could result in improper operation of the entire VAV system.

Install the factory-supplied duct static pressure probe with the tip facing into the airflow. See Fig. 10.

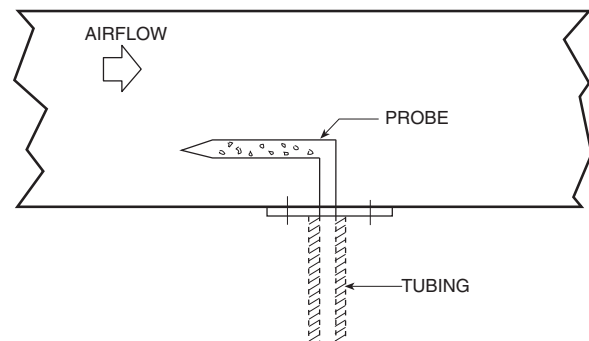

**Fig. 10 — Duct Static Pressure Probe**

Use 1/4-in. OD approved polyethylene tubing for up to 50 ft (3/8-in. OD for 50 to 100 ft) to connect the probe to the bulkhead fitting mounted above the unit display panel. Carefully route the tubing from the probe to this bulkhead fitting.

The static pressure control should be adjusted so that, at full airflow, all of the remote VAV terminal boxes receive the minimum static pressure required plus any downstream resistance. Control the system to the lowest static pressure set point that will satisfy airflow requirements. Lower static pressure set points reduce total required brake horsepower and reduce generated sound levels.

DUCT HIGH-STATIC (DHS) LIMIT SWITCH (VAV ONLY) — The duct high static limit switch is a mechanical safety that prevents duct overpressurization. The switch is optional and is field-provided.

**IMPORTANT:** Use tubing that complies with local codes. Improper location or installation of the supply duct pressure tubing will result in unsatisfactory unit operation and poor performance.

#### Step 4 — Make Piping Connections

CONDENSER WATER PIPING (WATER-COOLED ONLY) — Always follow national and local codes when installing water piping to ensure a safe and proper installation. Connections to the unit should incorporate vibration eliminators to reduce noise and vibration to the building, and shutoff valves to facilitate servicing.

Prior to connecting the unit(s) to the condenser water system, the system should be flushed to remove foreign material that could cause condenser fouling. Install a screen strainer with a minimum of 20 mesh ahead of the condenser inlet to prevent condenser fouling and internal condenser tube damage from foreign material.

Supply and return water piping must be at least as large as the unit connections, and larger for long runs. Refer to the System Design Manual, Part 3, and standard piping practice, when sizing, planning, and routing water piping. See dimension drawings (Fig. 2-8) for water connection sizes and locations.

Units are furnished standard with a copper heat exchanger. A cupronickel heat exchanger is also available as a factory-installed option. Copper is adequate for closed loop systems where good quality water is available. In conditions where scale formation or water treatment is questionable, the optional cupronickel heat exchanger should be used. Where the water is especially corrosive or could lead to excessive fouling, intermediate plate frame heat exchangers are recommended.

**⚠ CAUTION**

Galvanized pipe or fittings are not recommended with 50BV units due to the possibility of galvanic corrosion caused by dissimilar metals. When selecting piping materials, use only approved piping materials that meet applicable codes and that will handle the temperatures and pressures that may be experienced in the application. Piping systems will sweat if low temperature fluid is used in the system. For these applications, supply and return water piping should be insulated to protect from condensation damage. The minimum recommended entering water temperature to the unit is 50 F.

The unit is capable of operating with entering water temperatures as low as 50 F, without the need for head pressure control. If the entering water temperature is expected to be lower, or more stable unit operation is desired, a field-supplied water-regulating valve may be used.

This unit has multiple independent refrigerant circuits with separate condensers. The individual condensers are manifolded together on the waterside to provide easy, single-point water connections. In order to achieve proper head pressure control when a water-regulating valve is used, a temperature-actuated valve is recommended. This allows any of the independent refrigerant circuits to operate while still modulating condenser water flow in response to loop water temperature.

A glycol solution should be used if ambient temperatures are expected to fall below freezing or if the loop water temperature is below 50 F while operating. Refer to Table 4, which lists freezing points of glycol at different concentrations. A

minimum concentration of 20% is recommended. Water pressure drop will increase and unit performance will decrease with increasing glycol concentrations.

Units with factory-installed waterside economizers have cooling water passing through the economizer and condenser in series while operating in the economizer mode. During normal operation, water bypasses the economizer coil.

**Table 4 — Glycol Freezing Points**

% GLYCOL	FREEZE POINT (° F)	
	ETHYLENE GLYCOL	PROPLYLENE GLYCOL
20	18	19
30	7	9
40	-7	-5
50	-28	-27

All manual flow valves used in the system should be of the ball valve design. Globe or gate valves must not be used due to high pressure drops and poor throttling characteristics.

Do not exceed recommended condenser fluid flow rates shown in Tables 5 and 6. Serious damage or erosion of the heat exchanger tubes could occur. Piping systems should not exceed 10 fps fluid velocities to ensure quietness and tube wall integrity. Refer to Tables 5 and 6 for condenser water pressure drop versus flow rate. Flow rates outside of the published range should not be used.

**Table 5 — Condenser Pressure Drop 50BVC,J,Q Units**

FLOW RATE (GPM)	SIZE 020	SIZE 024	SIZE 028	SIZE 034
	PRESSURE DROP (FT WG)			
35	9.1	—	—	—
40	11.2	6.0	—	—
45	13.5	7.5	—	—
50	15.9	9.1	9.1	—
55	18.4	10.9	10.9	—
60	21.1	12.8	12.8	10.8
65	23.9	14.8	14.9	12.7
70	27.4	17.0	17.2	14.7
75	—	19.3	19.6	16.9
80	—	21.7	22.2	19.2
85	—	—	24.9	21.7
90	—	—	27.8	24.3
95	—	—	30.8	27.1
100	—	—	34.0	30.0
105	—	—	—	33.1
110	—	—	—	36.3
115	—	—	—	39.7
120	—	—	—	43.2

**Table 6 — Condenser Pressure Drop 50BVT,V,W Units**

FLOW RATE (GPM)	SIZE 034	SIZE 044	SIZE 054	SIZE 064
	PRESSURE DROP (FT WG)			
60	8.7	—	—	—
70	11.9	—	—	—
80	15.5	6.3	—	—
90	19.6	8.0	—	—
100	24.2	9.9	6.0	—
110	29.3	12.0	7.3	—
120	34.9	14.3	8.7	8.7
130	—	16.7	10.2	10.2
140	—	19.4	11.8	11.8
150	—	22.3	13.6	13.6
160	—	25.3	15.5	15.5
170	—	—	17.4	17.4
180	—	—	19.6	19.6
190	—	—	21.8	21.8
200	—	—	24.2	24.2
210	—	—	—	26.6
220	—	—	—	29.2
230	—	—	—	31.9
240	—	—	—	34.8

Ball valves should be installed in the supply and return lines for unit isolation and water flow balancing.

Pressure and temperature ports are recommended in both the supply and return lines for system flow balancing. These openings should be 5 to 10 pipe diameters from the unit water connections. For thorough mixing and temperature stabilization, wells in the water piping should extend at least  $\frac{1}{2}$  pipe diameter into the pipe. Measuring the condenser waterside pressure drop and referring to Tables 5 and 6 can help to properly set the water flow rate.

Improper fluid flow due to valving, piping, or improper pump operation constitutes abuse that may result in voiding of unit warranty. The manufacturer will not be responsible for damages or failures resulting from improper piping design or piping material selection.

**EVAPORATOR CONDENSATE DRAIN** — The condensate drain connection is  $1\frac{1}{4}$ -in. FPT and is located on the same side of the unit as the condenser water connections. See dimension drawings (Fig. 2-8) for exact location.

Drain lines should be pitched away from the unit with a minimum slope of  $\frac{1}{8}$ -in. per foot and conform to all local and national codes.

A trap must be installed in the condensate line to ensure free condensate flow (units are not internally trapped). A vertical air vent is sometimes required to avoid air pockets.

Install a condensate-trapping drain line at the unit's drain connection. See Fig. 11 for correct drain layout.

When calculating trap depth, remember that it is not the total static pressure but the upstream or downstream static resistance that is trapped against. For instance, when calculating the trap depth for a cooling coil condensate pan, trap against the coil pressure drop in that coil section and any other pressure drops upstream of it.

If calculating the trap depth for the cooling coil, use the total static pressure drop (coil plus any other components upstream of it) plus 1 in. ( $P_1 = \text{negative static pressure} + 1 \text{ in.}$ ), as shown in Fig. 11.

Traps must store enough condensate to prevent losing the drain seal at start-up. The “Minimum  $\frac{1}{2} P_1$ ” dimension ensures that enough condensate is stored.

Drain pans should be cleaned periodically to avoid the build-up of dirt and bacterial growth.

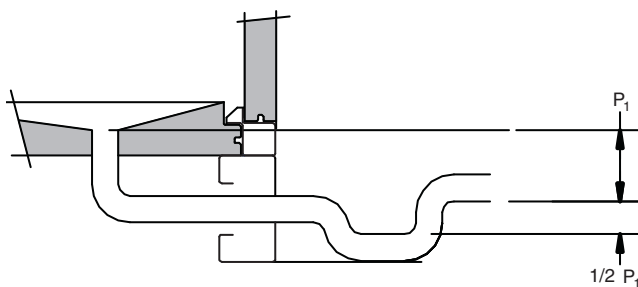

NOTE:  $P_1$  equals negative static pressure plus 1 inch.

**Fig. 11 — Condensate Drain Layout**

**HOT WATER HEATING COIL (OPTIONAL)** — A factory-installed one or 2-row hot water heating coil is available as an option. The coil is supplied with hot water from a boiler through separate piping from the condenser water loop. All controls for heating operation are field-supplied.

Piping should be in accordance with accepted industry standards and all components rated for the system pressure expected. Pipe coils so that they will drain, and provide a drain and vent.

Always connect the supply to the top of the coil, and the return to the bottom. Refer to Fig. 2-8 for hot water supply and return piping locations.

Water coils should not be subjected to entering-air temperatures below 38 F to prevent coil freeze-up. If air temperatures across the coil are going to be below this value, use a glycol or brine solution. Use a solution with the lowest concentration that will match the coldest air expected. Excess concentrations will greatly reduce coil capacity.

The return air duct system should be carefully designed to get adequate mixing of the return air and outdoor air streams to prevent cold spots on the coil that could freeze.

A 2 or 3-way, field-supplied modulating control valve or a simple two-position on-off valve may be used to control water flow. Select the valve based on the control valve manufacturer's recommendations for size and temperature rating. Select the control valve CV based on pressure drop and flow rate through the coil. This information is available from the SCU-Builder software program or Tables 7 and 8.

Pipe sizes should be selected based on the head pressure available from the pump. Water velocity should not exceed 8 fps. Design the piping system for approximately 3 ft of loss per 100 equivalent ft of pipe. The piping system should allow for expansion and minimize vibration between the unit and piping system.

**WATERSIDE ECONOMIZER (OPTIONAL)** — The optional waterside economizer (pre-cooling coil) is factory-installed and piped internally, in series with the condenser water circuit (Fig. 12). A diverting valve and factory controls are included with the option. Only one set of field connections needs to be made for condenser water and economizer water. In addition, when unit is shipped with economizer option, the economizer drain must be connected to a separate trap. Follow the same steps for the economizer drain as described for evaporator condensate drain. An aquastat is used to modulate water flow through the economizer. The controller is mounted to the low voltage control box. Electrical connections are factory installed and wired. The remote bulb is shipped internal to the unit and requires field mounting. Care should be taken not to dent the bulb or miscalibration may occur. The aquastat has a temperature range adjustment (-30 F to 100 F) and is field set. See Fig. 2-8 for connection locations and sizes. See Tables 9 and 10 for economizer waterside pressure drop data.



**Table 7 — Hot Water Pressure Drop  
50BVC,J,Q Units**

FLOW RATE (GPM)	SIZE 020	SIZE 024	SIZE 028	SIZE 034
	PRESSURE DROP (FT WG)			
10	0.7	0.7	0.7	—
15	1.5	1.5	1.5	—
20	2.6	2.6	2.6	—
25	4.0	4.0	4.0	—
30	5.8	5.8	5.8	0.1
35	7.8	7.8	7.8	0.1
40	10.2	10.2	10.2	0.1
45	12.9	12.9	12.9	0.2
50	15.8	15.8	15.8	0.2
55	—	—	—	0.3
60	—	—	—	0.3
65	—	—	—	0.4

**Table 9 — Economizer Pressure Drop Curve  
(ft wg), 50BVC,J,Q Units**

FLOW RATE (GPM)	SIZE 020	SIZE 024	SIZE 028	SIZE 034
	PRESSURE DROP (FT WG)			
35	8.9	—	—	—
40	11.5	11.0	—	—
45	14.4	13.8	—	—
50	17.6	16.9	16.9	—
55	21.1	20.4	20.4	—
60	24.9	24.1	24.1	3.5
65	29.0	28.1	28.2	4.1
70	34.4	32.5	32.5	4.7
75	—	37.1	37.2	5.4
80	—	42.1	42.1	6.1
85	—	—	47.4	6.9
90	—	—	52.9	7.7
95	—	—	58.7	8.5
100	—	—	64.9	9.4
105	—	—	—	10.3
110	—	—	—	11.3
115	—	—	—	12.3
120	—	—	—	13.4

**Table 8 — Hot Water Pressure Drop  
50BVT,V,W Units**

FLOW RATE (GPM)	SIZE 034	SIZE 044	SIZE 054	SIZE 064
	PRESSURE DROP (FT WG)			
45	2.4	—	—	—
50	3.0	—	—	—
55	3.6	—	—	—
60	4.3	—	—	—
65	5.0	—	—	—
70	5.7	—	—	—
75	6.6	—	—	—
80	7.4	—	—	—
85	8.4	—	—	—
90	9.3	2.5	2.5	2.5
100	—	3.1	3.1	3.1
110	—	3.7	3.7	3.7
120	—	4.4	4.4	4.4
130	—	5.1	5.1	5.1
140	—	5.9	5.9	5.9
150	—	6.7	6.7	6.7
160	—	7.6	7.6	7.6
170	—	8.6	8.6	8.6
180	—	9.6	9.6	9.6

**Table 10 — Economizer Pressure Drop Curve  
(ft wg), 50BVT,V,W Units**

FLOW RATE (GPM)	SIZE 034	SIZE 044	SIZE 054	SIZE 064
	PRESSURE DROP (FT WG)			
60	13.1	—	—	—
70	17.9	—	—	—
80	23.5	5.8	—	—
90	29.8	7.3	—	—
100	36.9	9.1	9.0	—
110	44.8	11.0	11.0	—
120	53.4	13.1	13.1	13.1
130	—	15.4	15.4	15.4
140	—	17.9	17.9	17.9
150	—	20.6	20.6	20.6
160	—	23.5	23.5	23.5
170	—	—	26.6	26.5
180	—	—	29.8	29.8
190	—	—	33.3	33.2
200	—	—	36.9	36.8
210	—	—	—	40.7
220	—	—	—	44.7
230	—	—	—	48.9
240	—	—	—	53.3

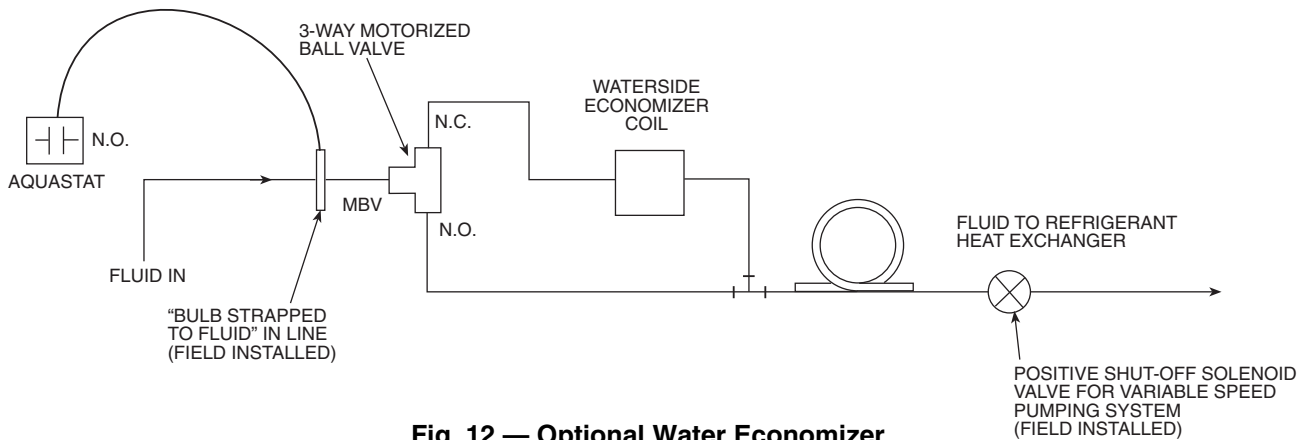

**Fig. 12 — Optional Water Economizer**

## Step 5 — Complete Electrical Connections —

Verify that electrical requirements listed on the unit nameplate match available power supply. The unit voltage must be within the range shown in Tables 11-13 and phases must be balanced within 2%. Contact the local power company for line voltage corrections. Never operate a motor where a phase imbalance in supply voltage is greater than 2%.

For an unbalanced 3-phase supply voltage, use the following formula to determine the percent of voltage imbalance:

Percent Voltage Imbalance

$$= 100 \times \frac{\text{max voltage deviation from average voltage}}{\text{average voltage}}$$

Example: Supply voltage is 460-3-60.

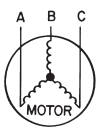

AB = 452 V

BC = 464 V

AC = 455 V

$$\begin{aligned} \text{Average Voltage} &= \frac{452 + 464 + 455}{3} \\ &= \frac{1371}{3} \\ &= 457 \end{aligned}$$

Determine maximum deviation from average voltage:

(AB)  $457 - 452 = 5 \text{ V}$

(BC)  $464 - 457 = 7 \text{ V}$

(AC)  $457 - 455 = 2 \text{ V}$

Maximum deviation is 7 V.

Determine percent of voltage imbalance:

$$\begin{aligned} \% \text{ Voltage Imbalance} &= 100 \times \frac{7}{457} \\ &= 1.53\% \end{aligned}$$

This amount of phase imbalance is satisfactory as it is below the maximum allowable 2%.

**IMPORTANT:** If supply voltage phase imbalance is more than 2%, contact the local electric utility company immediately.

**POWER WIRING** — Properly sized fuses or HACR (Heating, Air-Conditioning and Refrigeration) circuit breakers must be installed for branch circuit protection, according to the national and applicable local codes. See unit nameplate and Tables 11 and 12 for maximum overcurrent protection size.

These units are provided with single point, main power supply terminal blocks. Refer to Fig. 2-8 for conduit connection locations. Connect the power leads as indicated on the unit wiring diagrams (found in the Troubleshooting section) and be certain to connect the ground lead to the ground lug in the unit high voltage electrical box. Refer to Tables 11-13 for unit electrical data.

**Modular Units** — For units with multiple main air-conditioning sections, connect the high voltage compressor power wiring to the line side of the high voltage terminal block in the second section's high voltage electrical box. This wiring is located in the upper portion of the compressor compartment.

Connect the low voltage wiring, located in the compressor compartment, between the two air-conditioning sections using the quick connects provided.

For the supply fan motor, connect the 3-phase high voltage wiring, coiled behind the high voltage panel, to the line side of the supply fan motor terminal block located in the fan compartment. For VAV units, connect the 3-phase high voltage wiring to the line side of VFD.

For units with multiple fans, connect the control power wiring with the quick connects provided at the fan compartment junction.

**CONTROL WIRING (CV ONLY)** — A standard commercial thermostat controls constant volume units. These units turn compressors on or off in response to zone temperature. The 50BV units provide 2 stages of cooling.

**50BVC.Q020-034 and 50BVT.V034 Only** — These models have 2 independent refrigerant circuits, each capable of being staged independently. Thermostat wiring is connected to the 6-position low voltage terminal block located in the unit electrical box. The 50BV units have a 24-vac control transformer, which provides power to the control circuit and to the thermostat. The thermostat connections and their functions are as follows:

C	Transformer 24-vac Common
O	Reversing Valve (heat pumps only)
Y1	1st Stage Compressor Contactor
Y2	2nd Stage Compressor Contactor
R	Transformer 24-vac Hot
G	Indoor Fan Contactor

Select an appropriate commercial thermostat that has 2 stages of cooling control. If the unit is a heat pump, make sure the thermostat is capable of heat pump control.

Install the thermostat in the space where the temperature is being controlled, according to the instructions provided with the thermostat.

**⚠ WARNING**

Before wiring the thermostat to the unit, make sure that main power to the unit has been disconnected. Failure to heed this warning could result in personal injury.

To wire the thermostat:

1. Connect the 'C' terminal from the 50BV unit to the 'C' terminal on the thermostat.
2. Wire the 'Y1' and 'Y2' terminals from the 50BV unit to the 'Y1' and 'Y2' terminals, respectively, at the thermostat.
3. Make a connection between the 'G' terminal on the unit and the 'G' terminal on the thermostat.
4. Attach a wire from the 'R' terminal at the unit to the 'R' terminal at the thermostat.
5. 50BVQ and 50BVV ONLY: If the unit is a heat pump, connect a final wire from terminal 'O' on the heat pump unit to the 'W1/O/B' terminal at the thermostat. Configure the thermostat for heat pump operation using the installation instructions provided with the thermostat. Set the reversing valve polarity of the thermostat to 'O'.

See Fig. 13 for typical thermostat wiring.

**50BVT.V044-064 Only** — Unit sizes 044-064 have 4 independent refrigerant circuits. These units can be controlled using a standard commercial, 2-stage thermostat. In this case, the first stage of cooling will turn on compressors 1 and 2, and the second stage will turn on compressors 3 and 4. It is also possible to have 4 stages of cooling, using a suitable field-supplied control method.

For 2-stage thermostat wiring, refer to Fig. 14. Jumpers must be installed between the G and O terminals in Modules A and B. A field-supplied, 24-v pilot relay should be used to energize Y2 on Module B whenever Y1 is energized on Module A. Similarly, a field-supplied 24-v pilot relay should be installed to energize Y4 on Module B whenever Y3 on Module A is energized (Y2 stage of thermostat calls for cooling).

Finally, verify that transformer phasing is consistent between Modules A and B.

**Table 11 — Electrical Data — 50BVC,Q**

50BV UNIT SIZE (C, Q)	NOMINAL VOLTAGE (3 PH, 60 HZ)	VOLTAGE RANGE		COMPRESSOR			INDOOR FAN MOTOR			MIN CIRCUIT AMPS	MAX FUSE	FLA
		MIN	MAX	QUANTITY	RLA	LRA	QUANTITY	FLA	HP			
020	208/230	187	253	2	29.5	195	2	4.8	1½	76.0	100	68.6
							2	6.2	2	78.8	100	71.4
							2	9.2	3	84.8	110	77.4
							2	12.2	5	90.8	120	83.4
	460	414	506	2	14.7	95	2	2.4	1½	37.9	50	34.2
							2	3.1	2	39.3	50	35.6
							2	4.3	3	41.7	55	38.0
							2	6.1	5	45.3	60	41.6
	575	518	633	2	12.2	80	2	2.0	1½	31.5	40	28.4
							2	2.6	2	32.7	40	29.6
							2	3.7	3	34.9	45	31.8
							2	5.4	5	38.3	50	35.2
024	208/230	187	253	2	30.1	225	2	6.2	2	80.1	110	72.6
							2	9.2	3	86.1	110	78.6
							2	12.2	5	92.1	120	84.6
	460	414	506	2	16.7	114	2	3.1	2	43.8	60	39.6
							2	4.3	3	46.2	60	42.0
							2	6.1	5	49.8	60	45.6
	575	518	633	2	12.2	80	2	2.6	2	32.7	40	29.6
							2	3.7	3	34.9	45	31.8
							2	5.4	5	38.3	50	35.2
028	208/230	187	253	2	48.1	245	2	9.2	3	126.6	170	114.6
							2	12.2	5	132.6	180	120.6
	460	414	506	2	18.6	125	2	4.3	3	50.5	60	45.8
							2	6.1	5	54.1	70	49.4
	575	518	633	2	14.7	100	2	3.7	3	40.5	50	36.8
							2	5.4	5	43.9	50	40.2
034	208/230	187	253	2	55.8	340	2	9.2	3	144.0	190	130.0
							2	12.2	5	150.0	200	136.0
	460	414	506	2	26.9	173	2	4.3	3	69.1	90	62.4
							2	6.1	5	72.7	90	66.0
	575	518	633	2	23.7	132	2	3.7	3	60.7	80	54.8
							2	5.4	5	64.1	80	58.2

LEGEND

- FLA — Full Load Amps
- HP — Horsepower
- LRA — Locked Rotor Amps
- RLA — Rated Load Amps

**Table 12 — Electrical Data — 50BVJ**

50BV UNIT SIZE (J)	NOMINAL VOLTAGE (3 PH, 60 HZ)	VOLTAGE RANGE		COMPRESSOR			INDOOR FAN MOTOR			MIN CIRCUIT AMPS	MAX FUSE	FLA
		MIN	MAX	QUANTITY	RLA	LRA	QUANTITY	FLA	HP			
020	208/230	187	253	2	29.5	195	2	6.2	2	78.8	100	71.4
							2	8.8	3	84.0	110	76.6
							2	13.5	5	93.4	120	86.0
	460	414	506	2	14.7	95	2	3.1	2	39.3	50	35.6
							2	4.3	3	41.7	55	38.0
							2	6.2	5	45.5	60	41.8
024	208/230	187	253	2	30.1	225	2	6.2	2	80.1	110	72.6
							2	8.8	3	85.3	110	77.8
							2	13.5	5	94.7	120	87.2
	460	414	506	2	16.7	114	2	3.1	2	43.8	60	39.6
							2	4.3	3	46.2	60	42.0
							2	6.2	5	50.0	60	45.8
028	208/230	187	253	2	48.1	245	2	8.8	3	125.8	170	113.8
							2	13.5	5	135.2	180	123.2
	460	414	506	2	18.6	125	2	3.1	2	48.1	60	43.4
							2	4.3	3	50.5	60	45.8
034	208/230	187	253	2	55.8	340	2	8.8	3	143.2	200	129.2
							2	13.5	5	152.6	200	138.6
	460	414	506	2	26.9	173	2	3.1	2	66.7	90	60.0
							2	4.3	3	69.1	90	62.4

LEGEND

- FLA — Full Load Amps
- HP — Horsepower
- LRA — Locked Rotor Amps
- RLA — Rated Load Amps

**Table 13 — Electrical Data — 50BVT,V,W**

UNIT SIZE (T, V, W)	NOMINAL VOLTAGE (3 PH, 60 HZ)	VOLTAGE RANGE		COMPRESSOR			INDOOR FAN MOTOR			MIN CIRCUIT AMPS	MAX FUSE	FLA	
		MIN	MAX	QUANTITY	RLA	LRA	QUANTITY	FLA	HP				
034	208/230	187	253	2	50.6	325	1	19.4	7.5	152.7	175	120.6	
							1	25.8	10	165.5	190	127.0	
							1	38.6	15	191.1	200	139.8	
							1	49.6	20	213.1	200	150.8	
	460	414	506	2	26.9	173	1	9.7	7.5	70.2	90	63.5	
							1	12.9	10	73.4	100	66.7	
							1	19.3	15	79.8	100	73.1	
							1	24.8	20	85.3	110	78.6	
	575	518	633	2	23.7	132	1	7.8	7.5	61.1	80	55.2	
							1	10.3	10	63.6	80	57.7	
							1	15.4	15	68.7	90	62.8	
							1	19.8	20	73.1	90	67.2	
044	208/230	187	253	4	33.3	239	2	19.4	7.5	180.3	200	172.0	
							2	25.8	10	193.1	225	184.8	
							2	38.6	15	218.7	250	210.4	
	460	414	506	4	17.9	125	2	9.7	7.5	95.5	110	91.0	
							2	12.9	10	101.9	110	97.4	
							2	19.3	15	114.7	125	110.2	
	575	518	633	4	12.8	80	2	7.8	7.5	70.0	80	66.8	
							2	10.3	10	75.0	80	71.8	
							2	15.4	15	85.2	90	82.0	
	054	208/230	187	253	4	48.1	245	2	19.4	7.5	243.2	250	231.2
								2	25.8	10	256.0	300	244.0
								2	38.6	15	281.6	300	269.6
2								49.6	20	303.6	350	291.6	
460		414	506	4	18.6	125	2	9.7	7.5	98.5	110	93.8	
							2	12.9	10	104.9	110	100.2	
							2	19.3	15	117.7	125	113.0	
							2	24.8	20	128.7	125	124.0	
575		518	633	4	14.7	100	2	7.8	7.5	78.1	90	74.4	
							2	10.3	10	83.1	90	79.4	
							2	15.4	15	93.3	100	89.6	
							2	19.8	20	102.1	110	98.4	
064	208/230	187	253	4	50.6	325	2	19.4	7.5	253.9	300	241.2	
							2	25.8	10	266.7	300	254.0	
							2	38.6	15	292.3	300	279.6	
							2	49.6	20	314.3	350	301.6	
	460	414	506	4	26.9	173	2	9.7	7.5	133.7	150	127.0	
							2	12.9	10.0	140.1	150	133.4	
							2	19.3	15.0	152.9	175	146.2	
							2	24.8	20.0	163.9	175	157.2	
	575	518	633	4	23.7	132	2	7.8	7.5	116.3	140	110.4	
							2	10.3	10.0	121.3	140	115.4	
							2	15.4	15.0	131.5	150	125.6	
							2	19.8	20.0	140.3	150	134.4	

LEGEND

- FLA — Full Load Amps
- HP — Horsepower
- LRA — Locked Rotor Amps
- RLA — Rated Load Amps

**REMOTE CONDENSER FAN CONTACTOR WIRING** — For unit sizes 020-034, one remote condenser is required. Install a field-supplied 24-v pilot relay (Aux relay) between Y1 and C. This will energize the FC contactor on the remote condenser whenever there is a call for cooling.

For unit sizes 044-064, 2 remote condensers are required. Be sure to make piping connections so that compressors 1 and 2 are connected to condenser 1, and compressors 3 and 4 are connected to condenser 2. Use an additional set of NO (normally open) contacts on PR1 to energize FC1 on condenser 1, and a set of NO contacts on PR2 to energize FC1 on condenser 2.

**CONTROL WIRING (VAV ONLY)** — The VAV units are designed to operate either with a building management system or stand alone (local control). See Table 14 for cable recommendations.

**NOTE:** Conductors and drain wire must be at least 20 AWG (American Wire Gage), stranded, and tinned copper. Individual conductors must be insulated with PVC, PVC/nylon, vinyl, Teflon\*, or polyethylene. An aluminum/polyester 100% foil shield and an outer jacket of PVC, PVC/nylon, chrome vinyl, or Teflon with a minimum operating temperature range of -20 C to 60 C is required.

The communication bus shields must be tied together at each system element. If the communication bus is entirely within one building, the resulting continuous shield must be connected to ground at only one single point. If the communication bus cable exits from one building and enters another

building, the shields must be connected to the grounds at a lightning suppressor in each building (one point only).

**Wiring Control Devices** — Standard controls require no field wiring. Standard controls for VAV applications include: duct static pressure (DSP), compressor status (CHC1FLD), supply fan start/stop (SF), and supply fan speed (SPEED).

Field-installed devices and the factory-supplied supply air temperature sensor (required) will be wired in the field to the unit's direct digital control.

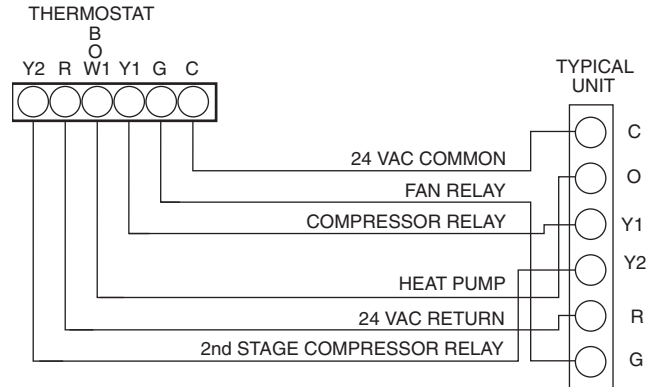

**Fig. 13 — Typical Wiring Unit Sizes 020-034 (Two-Stage Cooling Units)**

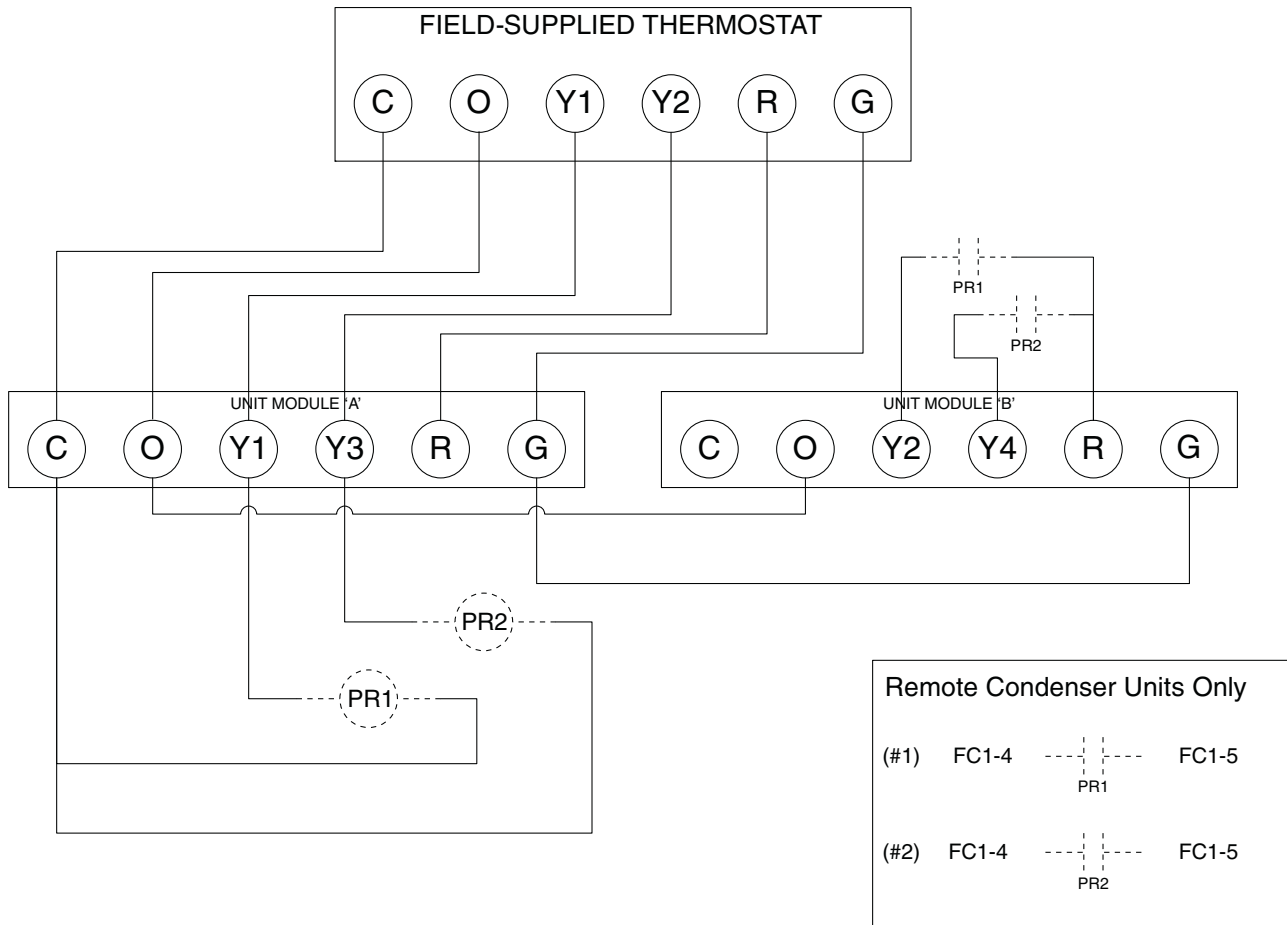

**LEGEND**

- FC** — Fan Contactor
- PR** — Pilot Relay

**Fig. 14 — Typical Wiring 40 to 60 Ton Units (Two-Stage Cooling)**

\*Teflon is a registered trademark of E.I. du Pont de Nemours and Company.

**Table 14 — Recommended Cables**

MANUFACTURER	PART NUMBER
Alpha	2413 or 5463
American	A22503
Belden	8772
Columbia	02525

**SUPPLY AIR TEMPERATURE SENSOR (SAT)** — The supply air temperature sensor is used to measure the temperature of the air leaving the unit. The sensor should be located in the supply air duct, about 1 ft from the unit discharge connection (Fig. 15). On units with 2 fans, locate the sensor approximately 5 duct diameters downstream from “pair of pants” duct connection, allowing for adequate mixing of supply air.

Mount the sensor as follows:

1. Remove the cover of the sensor junction box.
2. Drill a 7/16-in. hole at the selected location.
3. Install the sensor through the hole and secure using 2 no. 8 screws (provided). Do not overtighten.
4. Connect the sensor to the control box. Use an 18 or 20 AWG, 2 conductor, twisted pair cable. This cable is suitable for distances of up to 500 feet.

Connect the field wires to the supply air sensor using wire nuts or closed end style crimp connectors. Do not cut the sensor leads. Use the full length of lead supplied on the sensor.

In the control box, remove the jacket from the cable. Route the sensor wires over to the right side of the field terminal block (TB2). Strip the insulation back about 1/4-in. from each conductor. Connect the two wires to terminals 101 and 102 (SAT) on the terminal board. Polarity is not a consideration. See Table 15 for resistance vs. temperature values.

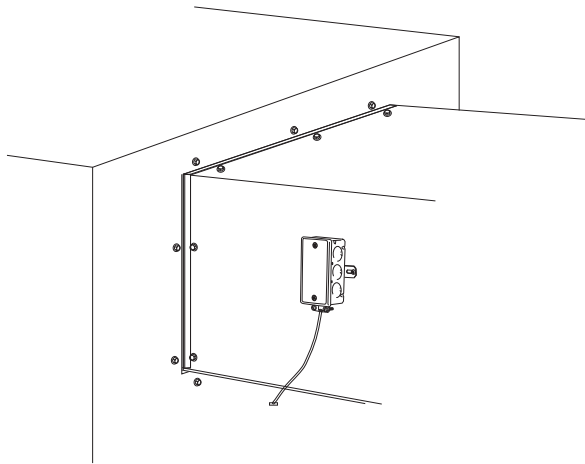
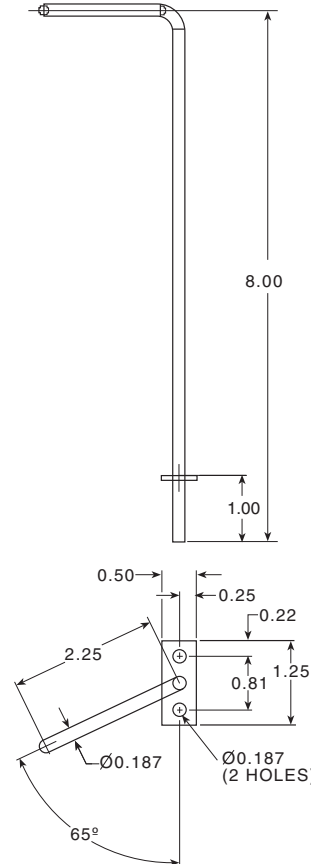

**Fig. 15 — Supply-Air Temperature Sensor Installation (Unit Discharge Location)**

**SMOKE DETECTOR/FIRE ALARM SHUTDOWN (FSD)** — To allow a smoke detector to shut the 50BV unit down, field terminate the sensor on IN-1 of the I/O Flex EX8160 expander. Use the BACview tool to enable its operation.

**REMOTE OCCUPANCY (ROCC)** — The 50BV unit may be commanded by another control system or a twist timer to become occupied and run when a set of dry contacts close. In order for this to occur, wire the NO dry contacts to UI-12 on the I/O Flex 6126 controller. From the BACview setup screen, configure the occupancy command to be Digital Input.

**RETURN AIR TEMPERATURE (RAT) SENSOR** — The return air temperature sensor is a 10K at 77 F temperature sensor used as the space control point. Refer to supply/discharge air control sequence of operation for the RAT functionality and configuration. Refer to Fig. 16.



NOTE: All dimensions are in inches.

**Fig. 16 — Return Air Temperature Sensor**

**Table 15 — Thermistor Resistance vs Temperature Values for Supply-Air and Return Air Temperature Sensor (10,000 ohms)**

TEMP (C)	TEMP (F)	RESISTANCE (OHMS)	TEMP (C)	TEMP (F)	RESISTANCE (OHMS)	TEMP (C)	TEMP (F)	RESISTANCE (OHMS)
-39	-39.44	323,839	37	2.78	28,365	113	45.00	4,367
-37	-38.33	300,974	39	3.89	26,834	115	46.11	4,182
-35	-37.22	279,880	41	5.00	25,395	117	47.22	4,006
-33	-36.11	260,410	43	6.11	24,042	119	48.33	3,838
-31	-35.00	242,427	45	7.22	22,770	121	49.44	3,679
-29	-33.89	225,809	47	8.33	21,573	123	50.56	3,525
-27	-32.78	210,443	49	9.44	20,446	125	51.67	3,380
-25	-31.67	196,227	51	10.56	19,376	127	52.78	3,242
-23	-30.56	183,068	53	11.67	18,378	129	53.89	3,111
-21	-29.44	170,775	55	12.78	17,437	131	55.00	2,985
-19	-28.33	159,488	57	13.89	16,550	133	56.11	2,865
-17	-27.22	149,024	59	15.00	15,714	135	57.22	2,751
-15	-26.11	139,316	61	16.11	14,925	137	58.33	2,642
-13	-25.00	130,306	63	17.22	14,180	139	59.44	2,538
-11	-23.89	121,939	65	18.33	13,478	141	60.56	2,438
-9	-22.78	114,165	67	19.44	12,814	143	61.67	2,343
-7	-21.67	106,939	69	20.56	12,182	145	62.78	2,252
-5	-20.56	100,218	71	21.67	11,590	147	63.89	2,165
-3	-19.44	93,909	73	22.78	11,030	149	65.00	2,082
-1	-18.33	88,090	75	23.89	10,501	151	66.11	2,003
1	-17.22	82,670	77	25.00	10,000	153	67.22	1,927
3	-16.11	77,620	79	26.11	9,526	155	68.33	1,855
5	-15.00	72,911	81	27.22	9,078	157	69.44	1,785
7	-13.89	68,518	83	28.33	8,653	159	70.56	1,718
9	-12.78	64,419	85	29.44	8,251	161	71.67	1,655
11	-11.67	60,592	87	30.56	7,866	163	72.78	1,594
13	-10.56	57,017	89	31.67	7,505	165	73.89	1,536
15	-9.44	53,647	91	32.78	7,163	167	75.00	1,480
17	-8.33	50,526	93	33.89	6,838	169	76.11	1,427
19	-7.22	47,606	95	35.00	6,530	171	77.22	1,375
21	-6.11	44,874	97	36.11	6,238	173	78.33	1,326
23	-5.00	42,317	99	37.22	5,960	175	79.44	1,279
25	-3.89	39,921	101	38.33	5,697	177	80.56	1,234
27	-2.78	37,676	103	39.44	5,447	179	81.67	1,190
29	-1.67	35,573	105	40.56	5,207	181	82.78	1,149
31	-0.56	33,599	107	41.67	4,981	183	83.89	1,109
33	0.56	31,732	109	42.78	4,766	185	85.00	1,070
35	1.67	29,996	111	43.89	4,561	187	86.11	1,034

**START-UP**

**General** — Complete the Start-Up Checklist on page CL-1 before attempting system start-up.

**CRANKCASE HEATERS** — The 50BVT,V,W,34-064 units include crankcase heaters. Crankcase heaters are energized as long as there is power to the unit.

*Wait 24 hours before starting the compressors to permit warming by the crankcase heaters.*

*AFTER 24 hours, continue with the procedures below.*

**CONFIRM THE INPUT POWER PHASE SEQUENCE** — The input power phase rotation sequence must be L1-L2-L3 = ABC (or forward or clockwise) as indicated with a phase rotation meter. Incorrect input phase rotation will cause the compressors to rotate in reverse, which results in no cooling capacity.

**IMPORTANT:** On VAV units, fan rotation direction CANNOT be used for the phase sequence check; fan rotation for VAV units with a variable speed drive is independent of the unit input wiring sequence.

If the compressor is rotating in the wrong direction, it may: emit increased noise; shut down due to internal overload protection; have only a small decrease in suction pressure when it starts; or have only a small increase in discharge pressure when it starts. Also, no cooling will be produced at the evaporator. If any of these conditions occurs, refer to the Service section to correct the compressor rotation before continuing.

**INTERNAL WIRING** — Check all electrical connections in unit control boxes; tighten as required.

**RETURN-AIR FILTERS** — Check that correct filters are installed in filter tracks (see Tables 2 and 3). Do not operate unit without return-air filters.

**COMPRESSOR MOUNTING** — Compressors are internally mounted on resilient rubber supports. Do not loosen or remove compressor holddown bolts.

**REFRIGERANT SERVICE PORTS** — Each refrigerant system has a total of 2 Schrader-type service gage ports per circuit. One port is located on the suction line, and one on the compressor discharge line. Be sure that caps on the ports are tight.



## CV Unit Start-Up

**EVAPORATOR FAN** — Fan belt and variable pitch motor pulleys are factory installed. See Tables 16-23 for fan performance data. Be sure that fans rotate in the proper direction.

**COOLING** — Set the space thermostat to OFF position. Turn on unit power. Set space thermostat to COOL and the fan to AUTO. Adjust the thermostat temperature setting below room temperature. Compressor 1 starts on closure of contactor (compressors 1 and 2 on 4-circuit units with 2-stage thermostat).

Adjust the thermostat to an even lower setting until the thermostat energizes Y2 (the second cooling stage). Compressor 2 starts on closure of contactor (compressors 3 and 4 on 4-circuit units with 2-stage thermostat).

Adjust the thermostat temperature to a setting just below room temperature. The second stage of cooling should turn off.

Set the thermostat temperature above room temperature. All compressors and the unit fan should now be off.

Set the thermostat below room temperature and confirm that the compressors and fan turn off.

**Table 16 — Fan Performance — 50BVC,Q020**

AIRFLOW (CFM)	AVAILABLE EXTERNAL STATIC PRESSURE (in. wg)														
	0.2			0.4			0.6			0.8			1.0		
	RPM	WATTS	BHP	RPM	WATTS	BHP	RPM	WATTS	BHP	RPM	WATTS	BHP	RPM	WATTS	BHP
4500	—	—	—	—	—	—	623	459	0.52	—	—	—	—	—	—
5000	—	—	—	—	—	—	638	545	0.61	—	—	—	—	—	—
5500	—	—	—	—	—	—	655	641	0.72	725	755	0.85	—	—	—
6000	—	—	—	608	641	0.72	676	755	0.85	742	878	0.99	807	1001	1.13
6500	—	—	—	636	755	0.85	699	878	0.99	761	1010	1.14	821	1142	1.29
7000	604	774	0.87	666	906	1.02	726	1029	1.16	784	1170	1.32	841	1311	1.48
7500	634	916	1.03	693	1057	1.19	750	1189	1.34	805	1330	1.50	858	1480	1.67
8000	667	1085	1.22	723	1226	1.38	777	1377	1.55	829	1526	1.72	880	1676	1.89
8500	700	1273	1.43	753	1423	1.60	804	1573	1.77	853	1732	1.95	902	1836	2.13
9000	735	1480	1.67	785	1638	1.84	833	1745	2.02	881	1908	2.21	927	2071	2.40

AIRFLOW (CFM)	AVAILABLE EXTERNAL STATIC PRESSURE (in. wg)														
	1.2			1.4			1.6			1.8			2.0		
	RPM	WATTS	BHP	RPM	WATTS	BHP	RPM	WATTS	BHP	RPM	WATTS	BHP	RPM	WATTS	BHP
4500	—	—	—	—	—	—	—	—	—	—	—	—	—	—	—
5000	—	—	—	—	—	—	—	—	—	—	—	—	—	—	—
5500	—	—	—	—	—	—	—	—	—	—	—	—	—	—	—
6000	—	—	—	—	—	—	—	—	—	—	—	—	—	—	—
6500	881	1283	1.44	—	—	—	—	—	—	—	—	—	—	—	—
7000	897	1451	1.63	951	1601	1.80	—	—	—	—	—	—	—	—	—
7500	911	1629	1.83	963	1727	2.00	1014	1881	2.18	—	—	—	—	—	—
8000	930	1781	2.07	979	1935	2.24	1028	2098	2.43	1076	2260	2.62	1124	2422	2.81
8500	950	1989	2.31	997	2152	2.50	1043	2323	2.69	1089	2485	2.88	1134	2697	3.09
9000	973	2233	2.59	1018	2404	2.79	1062	2576	2.99	1106	2779	3.18	1149	2960	3.39

**LEGEND**

**Bhp** — Brake Horsepower Input to Supply Fan  
**Watts** — Input Power to Supply Fan Motor

**NOTES:**

- Units are available with the following motor and drive combinations: 1.5, 2, 3, 5 hp standard drive; 1.5, 2, 3 hp medium static drive. For 1.5, 2, 3 hp standard drives, the drive range is 753 to 952 rpm. For medium static drives, the drive range is 872 to 1071 rpm. For 5 hp standard drives, the drive range is 967 to 1290 rpm.

- Italics** indicates field-supplied drive required.
- Do not operate in shaded area.
- Static pressure losses must be applied to external static pressure before entering the fan performance table.
- Interpolation is permitted; extrapolation is not.
- Fan performance is based on filter, unit casing, and wet coil losses.
- Bhp values are *per fan*. Watts values are *per motor*. Unit has 2 supply fans and 2 motors.

Table 17 — Fan Performance — 50BVC,Q024

AIRFLOW (CFM)	AVAILABLE EXTERNAL STATIC PRESSURE (in. wg)														
	0.2			0.4			0.6			0.8			1.0		
	RPM	WATTS	BHP	RPM	WATTS	BHP	RPM	WATTS	BHP	RPM	WATTS	BHP	RPM	WATTS	BHP
5,000	—	—	—	—	—	—	<i>638</i>	<i>545</i>	<i>0.61</i>	—	—	—	—	—	—
5,500	—	—	—	—	—	—	<i>655</i>	<i>641</i>	<i>0.72</i>	<i>725</i>	<i>755</i>	<i>0.85</i>	—	—	—
6,000	—	—	—	<i>608</i>	<i>641</i>	<i>0.72</i>	<i>676</i>	<i>755</i>	<i>0.85</i>	<i>742</i>	<i>878</i>	<i>0.99</i>	807	1001	1.13
6,500	—	—	—	<i>636</i>	<i>755</i>	<i>0.85</i>	<i>699</i>	<i>878</i>	<i>0.99</i>	761	1010	1.14	821	1142	1.29
7,000	<i>604</i>	<i>774</i>	<i>0.87</i>	<i>666</i>	<i>906</i>	<i>1.02</i>	<i>726</i>	<i>1029</i>	<i>1.16</i>	784	1170	1.32	841	1311	1.48
7,500	<i>634</i>	<i>916</i>	<i>1.03</i>	<i>693</i>	<i>1057</i>	<i>1.19</i>	<i>750</i>	<i>1189</i>	<i>1.34</i>	805	1330	1.50	858	1480	1.67
8,000	<i>667</i>	<i>1085</i>	<i>1.22</i>	<i>723</i>	<i>1226</i>	<i>1.38</i>	777	1377	1.55	829	1526	1.72	880	1676	1.89
8,500	<i>700</i>	<i>1273</i>	<i>1.43</i>	753	1423	1.60	804	1573	1.77	853	1732	1.95	902	1836	2.13
9,000	<i>735</i>	<i>1480</i>	<i>1.67</i>	785	1638	1.84	833	1745	2.02	881	1908	2.21	927	2071	2.40
9,500	769	1713	1.93	816	1827	2.12	863	1989	2.31	908	2152	2.50	952	2323	2.69
10,000	802	1908	2.21	848	2080	2.41	892	2251	2.61	936	2422	2.81	978	2624	3.01

AIRFLOW (CFM)	AVAILABLE EXTERNAL STATIC PRESSURE (in. wg)														
	1.2			1.4			1.6			1.8			2.0		
	RPM	WATTS	BHP	RPM	WATTS	BHP	RPM	WATTS	BHP	RPM	WATTS	BHP	RPM	WATTS	BHP
5,000	—	—	—	—	—	—	—	—	—	—	—	—	—	—	—
5,500	—	—	—	—	—	—	—	—	—	—	—	—	—	—	—
6,000	—	—	—	—	—	—	—	—	—	—	—	—	—	—	—
6,500	881	1283	1.44	—	—	—	—	—	—	—	—	—	—	—	—
7,000	897	1451	1.63	951	1601	1.80	—	—	—	—	—	—	—	—	—
7,500	911	1629	1.83	963	1727	2.00	1014	1881	2.18	—	—	—	—	—	—
8,000	930	1781	2.07	979	1935	2.24	1028	2098	2.43	1076	2260	2.62	1124	2422	2.81
8,500	950	1989	2.31	997	2152	2.50	1043	2323	2.69	1089	2485	2.88	1134	2697	3.09
9,000	973	2233	2.59	1018	2404	2.79	1062	2576	2.99	1106	2779	3.18	1149	2960	3.39
9,500	996	2494	2.89	1039	2697	3.09	1081	2879	3.30	1123	3060	3.51	1165	3251	3.73
10,000	1020	2806	3.22	1061	2988	3.42	1102	3178	3.64	1142	3360	3.85	1182	3559	4.08

LEGEND

**Bhp** — Brake Horsepower Input to Supply Fan  
**Watts** — Input Power to Supply Fan Motor

NOTES:

- Units are available with the following motor and drive combinations: 2, 3, and 5 hp standard drive; 2, 3 hp medium static drive. For 2, 3 hp standard drives, the drive range is 753 to 952 rpm. For medium static drives, the drive range is 872 to 1071 rpm. For 5 hp standard drives, the drive range is 967 to 1290 rpm.

- Italics* indicates field-supplied drive required.
- Do not operate in shaded area.
- Static pressure losses must be applied to external static pressure before entering the fan performance table.
- Interpolation is permitted; extrapolation is not.
- Fan performance is based on filter, unit casing, and wet coil losses.
- Bhp values are *per fan*. Watts values are *per motor*. Unit has 2 supply fans and 2 motors.

Table 18 — Fan Performance — 50BVC,Q028

AIRFLOW (CFM)	AVAILABLE EXTERNAL STATIC PRESSURE (in. wg)														
	0.2			0.4			0.6			0.8			1.0		
	RPM	WATTS	BHP	RPM	WATTS	BHP	RPM	WATTS	BHP	RPM	WATTS	BHP	RPM	WATTS	BHP
6,250	—	—	—	624	678	0.79	689	797	0.92	753	917	1.06	815	1045	1.21
7,000	604	751	0.87	666	880	1.02	726	999	1.16	784	1136	1.32	841	1273	1.48
7,500	634	889	1.03	693	1027	1.19	750	1155	1.34	805	1291	1.50	858	1437	1.67
8,000	667	1054	1.22	723	1191	1.38	777	1337	1.55	829	1482	1.72	880	1627	1.89
8,500	700	1237	1.43	753	1382	1.60	804	1528	1.77	853	1682	1.95	902	1836	2.13
9,000	735	1437	1.67	785	1591	1.84	833	1745	2.02	881	1908	2.21	927	2071	2.40
9,500	769	1664	1.93	816	1827	2.12	863	1989	2.31	908	2152	2.50	952	2323	2.69
10,000	802	1908	2.21	848	2080	2.41	892	2251	2.61	936	2422	2.81	978	2624	3.01
10,500	835	2179	2.53	879	2350	2.73	921	2531	2.93	963	2742	3.14	1004	2924	3.35
11,000	870	2467	2.86	912	2688	3.08	952	2870	3.29	992	3060	3.51	1032	3251	3.73
11,500	904	2824	3.24	944	3015	3.46	983	3206	3.67	1022	3405	3.90	1060	3605	4.13
12,000	937	3169	3.63	976	3369	3.86	1014	3569	4.09	1051	3777	4.33	1088	3985	4.57
12,500	972	3550	4.07	1010	3759	4.31	1046	3967	4.55	1082	4184	4.80	—	—	—

AIRFLOW (CFM)	AVAILABLE EXTERNAL STATIC PRESSURE (in. wg)														
	1.2			1.4			1.6			1.8			2.0		
	RPM	WATTS	BHP	RPM	WATTS	BHP	RPM	WATTS	BHP	RPM	WATTS	BHP	RPM	WATTS	BHP
6,250	877	1173	1.36	—	—	—	—	—	—	—	—	—	—	—	—
7,000	897	1410	1.63	951	1555	1.80	—	—	—	—	—	—	—	—	—
7,500	911	1582	1.83	963	1727	2.00	1014	1881	2.18	—	—	—	—	—	—
8,000	930	1781	2.07	979	1935	2.24	1028	2098	2.43	1076	2260	2.62	1124	2422	2.81
8,500	950	1989	2.31	997	2152	2.50	1043	2323	2.69	1089	2485	2.88	1134	2697	3.09
9,000	973	2233	2.59	1018	2404	2.79	1062	2576	2.99	1106	2779	3.18	1149	2960	3.39
9,500	996	2494	2.89	1039	2697	3.09	1081	2879	3.30	1123	3060	3.51	1165	3251	3.73
10,000	1020	2806	3.22	1061	2988	3.42	1102	3178	3.64	1142	3360	3.85	1182	3559	4.08
10,500	1044	3106	3.56	1084	3296	3.78	1123	3496	4.01	1161	3686	4.23	1200	3886	4.45
11,000	1070	3451	3.95	1109	3641	4.17	1146	3840	4.40	1184	4049	4.64	1220	4248	4.87
11,500	1097	3804	4.36	1134	4012	4.60	1170	4221	4.84	1206	—	—	—	—	—
12,000	1124	4193	4.81	—	—	—	—	—	—	—	—	—	—	—	—
12,500	—	—	—	—	—	—	—	—	—	—	—	—	—	—	—

LEGEND

**Bhp** — Brake Horsepower Input to Supply Fan  
**Watts** — Input Power to Supply Fan Motor

NOTES:

- Units are available with 3 or 5 hp standard drive or 3 hp medium static drive.  
 For 3 hp standard drives, the drive range is 753 to 952 rpm. For medium static drives, the drive range is 872 to 1071 rpm. 5 hp standard drives have drive range of 967 to 1290 rpm.

- Italics* indicates field-supplied drive required.
- Do not operate in shaded area.
- Static pressure losses must be applied to external static pressure before entering the fan performance table.
- Interpolation is permitted; extrapolation is not.
- Fan performance is based on filter, unit casing, and wet coil losses.
- Bhp values are *per fan*. Watts values are *per motor*. Unit has 2 supply fans and 2 motors.

Table 19 — Fan Performance — 50BVC,Q034

AIRFLOW (CFM)	AVAILABLE EXTERNAL STATIC PRESSURE (in. wg)														
	0.2			0.4			0.6			0.8			1.0		
	RPM	WATTS	BHP	RPM	WATTS	BHP	RPM	WATTS	BHP	RPM	WATTS	BHP	RPM	WATTS	BHP
9,000	639	1187	1.36	693	1334	1.53	745	1490	1.71	795	1646	1.89	843	1802	2.07
9,500	665	1362	1.56	717	1518	1.74	766	1674	1.92	814	1839	2.11	861	2004	2.30
10,000	693	1555	1.78	743	1720	1.97	791	1894	2.17	836	2058	2.36	881	2232	2.56
10,500	721	1775	2.03	769	1949	2.23	815	2122	2.43	859	2296	2.63	902	2478	2.84
11,000	749	2004	2.30	795	2186	2.51	840	2369	2.71	882	2551	2.92	924	2742	3.14
11,500	777	2259	2.59	822	2451	2.81	864	2642	3.03	906	2833	3.25	946	3024	3.47
12,000	805	2533	2.90	848	2733	3.13	889	2933	3.36	929	3133	3.59	968	3333	3.82
12,500	835	2842	3.26	877	3042	3.49	917	3251	3.73	955	3460	3.97	993	3668	4.20
13,000	865	3169	3.63	905	3378	3.87	944	3596	4.12	981	3813	4.37	1018	4021	4.61
13,500	894	3514	4.03	933	3741	4.29	971	3958	4.54	1007	4184	4.80	—	—	—
14,000	924	3895	4.46	961	4121	4.72	998	4356	4.99	—	—	—	—	—	—

AIRFLOW (CFM)	AVAILABLE EXTERNAL STATIC PRESSURE (in. wg)														
	1.2			1.4			1.6			1.8			2.0		
	RPM	WATTS	BHP	RPM	WATTS	BHP	RPM	WATTS	BHP	RPM	WATTS	BHP	RPM	WATTS	BHP
9,000	890	1958	2.24	936	2122	2.43	982	2296	2.63	1026	2460	2.82	1071	2642	3.03
9,500	906	2168	2.48	950	2341	2.68	994	2515	2.88	1037	2688	3.08	1079	2870	3.29
10,000	925	2405	2.76	967	2578	2.96	1009	2760	3.16	1051	2942	3.37	1092	3124	3.58
10,500	944	2660	3.05	986	2842	3.26	1026	3024	3.47	1066	3215	3.68	1105	3405	3.90
11,000	965	2924	3.35	1004	3115	3.57	1043	3315	3.80	1082	3505	4.02	1120	3705	4.25
11,500	985	3224	3.69	1024	3414	3.91	1062	3614	4.14	1099	3813	4.37	1136	4021	4.61
12,000	1006	3532	4.05	1044	3732	4.28	1080	3940	4.52	1117	4148	4.75	1152	4356	4.99
12,500	1030	3877	4.44	1066	4085	4.68	1102	4302	4.93	—	—	—	—	—	—
13,000	1053	4239	4.86	—	—	—	—	—	—	—	—	—	—	—	—
13,500	—	—	—	—	—	—	—	—	—	—	—	—	—	—	—
14,000	—	—	—	—	—	—	—	—	—	—	—	—	—	—	—

LEGEND

**Bhp** — Brake Horsepower Input to Supply Fan  
**Watts** — Input Power to Supply Fan Motor

NOTES:

- Unit is available with 5 hp standard drive only. The drive range is 967 to 1290 rpm.
- Italics** indicates field-supplied drive required.

-  Do not operate in shaded area.
- Static pressure losses must be applied to external static pressure before entering the fan performance table.
- Interpolation is permitted; extrapolation is not.
- Fan performance is based on filter, unit casing, and wet coil losses.
- Bhp values are *per fan*. Watts values are *per motor*. Unit has 2 supply fans and 2 motors.

Table 20 — Fan Performance — 50BVT,V034

AIRFLOW (CFM)	AVAILABLE EXTERNAL STATIC PRESSURE (in. wg)														
	0.2			0.4			0.6			0.8			1.0		
	RPM	WATTS	BHP	RPM	WATTS	BHP	RPM	WATTS	BHP	RPM	WATTS	BHP	RPM	WATTS	BHP
9,000	564	3,167	3.76	605	3,483	4.13	645	3,798	4.51	683	4,112	4.88	718	4,392	5.21
9,500	590	3,666	4.35	629	3,999	4.74	667	4,331	5.14	704	4,671	5.54	738	4,977	5.90
10,000	617	4,226	5.01	655	4,584	5.44	691	4,933	5.85	726	5,282	6.27	761	5,654	6.71
10,500	643	4,820	5.72	678	5,194	6.16	713	5,583	6.62	747	5,963	7.07	780	6,263	7.51
11,000	669	5,503	6.53	704	5,901	7.00	737	6,298	7.47	770	6,612	7.93	802	7,005	8.40
11,500	696	6,236	7.40	729	6,577	7.89	761	6,987	8.38	792	7,388	8.86	823	7,798	9.36
12,000	722	6,952	8.34	754	7,380	8.85	784	7,798	9.36	815	8,225	9.87	845	8,510	10.38
12,500	750	7,816	9.38	780	8,260	9.91	810	8,561	10.44	839	8,990	10.97	868	9,427	11.50
13,000	777	8,595	10.49	806	9,050	11.04	835	9,504	11.59	863	9,949	12.14	891	10,403	12.69
13,500	804	9,572	11.68	832	10,043	12.25	860	10,514	12.83	887	10,985	13.40	914	11,447	13.96
14,000	832	10,634	12.97	859	11,122	13.57	886	11,610	14.16	912	12,097	14.76	938	12,585	15.35
14,500	859	11,747	14.33	885	12,217	14.90	911	12,756	15.56	936	13,260	16.18	962	13,765	16.79
15,000	886	12,953	15.80	911	13,474	16.44	936	13,996	17.07	961	14,517	17.71	986	15,038	18.34

AIRFLOW (CFM)	AVAILABLE EXTERNAL STATIC PRESSURE (in. wg)														
	1.2			1.4			1.6			1.8			2.0		
	RPM	WATTS	BHP	RPM	WATTS	BHP	RPM	WATTS	BHP	RPM	WATTS	BHP	RPM	WATTS	BHP
9,000	751	4,663	5.53	785	4,933	5.85	817	5,212	6.18	849	5,512	6.54	881	5,804	6.89
9,500	771	5,264	6.25	802	5,574	6.61	834	5,866	6.96	864	6,166	7.31	895	6,394	7.67
10,000	792	5,963	7.07	822	6,272	7.44	852	6,498	7.80	882	6,804	8.16	911	7,118	8.54
10,500	812	6,603	7.92	841	6,926	8.31	870	7,240	8.69	899	7,563	9.07	927	7,885	9.46
11,000	833	7,388	8.86	861	7,720	9.26	889	8,051	9.66	917	8,253	10.07	944	8,578	10.46
11,500	854	8,199	9.84	882	8,441	10.30	909	8,784	10.72	936	9,127	11.13	962	9,469	11.55
12,000	874	8,921	10.88	903	9,332	11.38	930	9,701	11.83	955	10,060	12.27	981	10,420	12.71
12,500	896	9,855	12.02	924	10,283	12.54	951	10,702	13.06	976	11,079	13.51	1001	11,456	13.97
13,000	919	10,857	13.24	945	11,302	13.79	972	11,747	14.33	997	12,166	14.84	1022	12,551	15.31
13,500	941	11,918	14.54	967	12,380	15.10	993	12,850	15.67	1018	13,303	16.23	1042	13,722	16.74
14,000	964	13,064	15.94	990	13,551	16.53	1015	14,030	17.11	1040	14,517	17.71	1064	14,979	18.27
14,500	987	14,269	17.41	1011	14,765	18.01	1036	15,261	18.62	1060	15,765	19.23	1084	16,260	19.83
15,000	1010	15,560	18.98	1034	16,081	19.62	—	—	—	—	—	—	—	—	—

LEGEND

**Bhp** — Brake Horsepower Input to Supply Fan  
**Watts** — Input Power to Supply Fan Motor

NOTES:

- Unit is available with the following motor and drive combinations: 7.5, 10, 15, 20 hp standard drive; 7.5, 10, 15, 20 hp medium-static drive; 7.5, 10, 15, 20 hp high-static drive.  
 For 7.5 hp standard drives, the drive range is 780 to 960 rpm. For 10, 15, 20 hp standard and 7.5 hp medium-static drives, the drive range is 805 to 991 rpm. For 10, 15, 20 hp medium-static and 7.5 hp high-static drives the drive range is 960 to 1146 rpm. For 10, 15, 20 hp high-static drives the drive range is 1119 to 1335 rpm.

- Italics** indicates field-supplied drive required.
- Do not operate in shaded area.
- Static pressure losses must be applied to external static pressure before entering the fan performance table.
- Interpolation is permitted; extrapolation is not.
- Fan performance is based on filter, unit casing, and wet coil losses.
- This unit has one supply fan and one fan motor.

**Table 20 — Fan Performance — 50BVT,V034 (cont)**

AIRFLOW (CFM)	AVAILABLE EXTERNAL STATIC PRESSURE (in. wg)														
	2.2			2.4			2.6			2.8			3.0		
	RPM	WATTS	BHP	RPM	WATTS	BHP	RPM	WATTS	BHP	RPM	WATTS	BHP	RPM	WATTS	BHP
9,000	912	6,095	7.23	943	6,324	7.59	974	6,629	7.95	1005	6,943	8.33	1035	7,266	8.72
9,500	925	6,690	8.03	955	6,996	8.39	984	7,310	8.77	1013	7,624	9.15	1042	7,955	9.54
10,000	940	7,423	8.91	969	7,746	9.29	997	8,060	9.67	1025	8,253	10.07	1053	8,578	10.46
10,500	955	8,199	9.84	982	8,390	10.23	1010	8,715	10.63	1037	9,041	11.03	1063	9,375	11.44
11,000	971	8,913	10.87	998	9,238	11.27	1024	9,572	11.68	1050	9,915	12.09	1076	10,257	12.51
11,500	988	9,812	11.97	1014	10,155	12.39	1040	10,506	12.82	1065	10,848	13.23	1090	11,207	13.67
12,000	1006	10,771	13.14	1031	11,130	13.58	1056	11,490	14.02	1080	11,849	14.45	1104	12,217	14.90
12,500	1025	11,824	14.42	1050	12,191	14.87	1074	12,568	15.33	1097	12,944	15.79	1121	13,320	16.25
13,000	1045	12,936	15.78	1069	13,320	16.25	1092	13,714	16.73	1115	14,098	17.20	1138	14,492	17.68
13,500	1065	14,124	17.23	1088	14,526	17.72	1110	14,927	18.21	1133	15,329	18.70	1155	15,731	19.19
14,000	1086	15,397	18.78	1108	15,816	19.29	1131	16,235	19.80	—	—	—	—	—	—
14,500	—	—	—	—	—	—	—	—	—	—	—	—	—	—	—
15,000	—	—	—	—	—	—	—	—	—	—	—	—	—	—	—

AIRFLOW (CFM)	AVAILABLE EXTERNAL STATIC PRESSURE (in. wg)														
	3.2			3.4			3.6			3.8			4.0		
	RPM	WATTS	BHP	RPM	WATTS	BHP	RPM	WATTS	BHP	RPM	WATTS	BHP	RPM	WATTS	BHP
9,000	1065	7,606	9.13	1095	7,946	9.53	—	—	—	—	—	—	—	—	—
9,500	1071	8,286	9.94	1100	8,493	10.36	1128	8,835	10.78	1157	9,195	11.22	1185	9,564	11.67
10,000	1081	8,904	10.86	1108	9,247	11.28	1136	9,598	11.71	1163	9,958	12.15	1190	10,326	12.60
10,500	1090	9,718	11.85	1116	10,060	12.27	1143	10,411	12.70	1169	10,771	13.14	1195	11,139	13.59
11,000	1102	10,608	12.94	1127	10,959	13.37	1153	11,319	13.81	1178	11,678	14.25	1203	12,046	14.69
11,500	1115	11,558	14.10	1139	11,918	14.54	1164	12,286	14.99	1188	12,653	15.43	1212	13,038	15.90
12,000	1128	12,585	15.35	1152	12,953	15.80	1176	13,329	16.26	1200	13,705	16.72	1223	14,090	17.19
12,500	1144	13,697	16.71	1167	14,073	17.17	1190	14,457	17.64	1213	14,850	18.12	1236	15,235	18.58
13,000	1160	14,876	18.15	1183	15,269	18.63	1205	15,662	19.11	1227	16,064	19.60	—	—	—
13,500	1177	16,132	19.68	—	—	—	—	—	—	—	—	—	—	—	—
14,000	—	—	—	—	—	—	—	—	—	—	—	—	—	—	—
14,500	—	—	—	—	—	—	—	—	—	—	—	—	—	—	—
15,000	—	—	—	—	—	—	—	—	—	—	—	—	—	—	—

**LEGEND**

**Bhp** — Brake Horsepower Input to Supply Fan  
**Watts** — Input Power to Supply Fan Motor

**NOTES:**

- Unit is available with the following motor and drive combinations: 7.5, 10, 15, 20 hp standard drive; 7.5, 10, 15, 20 hp medium-static drive; 7.5, 10, 15, 20 hp high-static drive.  
 For 7.5 hp standard drives, the drive range is 780 to 960 rpm. For 10, 15, 20 hp standard and 7.5 hp medium-static drives, the drive range is 805 to 991 rpm. For 10, 15, 20 hp medium-static and 7.5 hp high-static drives the drive range is 960 to 1146 rpm. For 10, 15, 20 hp high-static drives the drive range is 1119 to 1335 rpm.

- Italics* indicates field-supplied drive required.
- Do not operate in shaded area.
- Static pressure losses must be applied to external static pressure before entering the fan performance table.
- Interpolation is permitted; extrapolation is not.
- Fan performance is based on filter, unit casing, and wet coil losses.
- This unit has one supply fan and one fan motor.

Table 21 — Fan Performance — 50BVT,V044

AIRFLOW (CFM)	AVAILABLE EXTERNAL STATIC PRESSURE (lin. wg)														
	0.2			0.4			0.6			0.8			1.0		
	RPM	WATTS	BHP	RPM	WATTS	BHP	RPM	WATTS	BHP	RPM	WATTS	BHP	RPM	WATTS	BHP
12,000	403	1057	1.25	461	1271	1.51	512	1458	1.73	561	1644	1.95	608	1838	2.18
12,500	413	1173	1.39	470	1395	1.66	519	1591	1.89	567	1785	2.12	613	1980	2.35
13,000	423	1280	1.52	478	1520	1.80	527	1723	2.04	573	1927	2.29	618	2130	2.53
13,500	436	1422	1.69	489	1661	1.97	537	1883	2.23	582	2086	2.47	626	2297	2.73
14,000	446	1546	1.83	498	1803	2.14	546	2033	2.41	589	2253	2.67	632	2465	2.92
14,500	459	1706	2.02	509	1962	2.33	557	2209	2.62	599	2438	2.89	640	2658	3.15
15,000	469	1847	2.19	518	2121	2.52	565	2385	2.83	607	2614	3.10	647	2843	3.37
16,000	495	2200	2.61	541	2482	2.94	585	2772	3.29	627	3036	3.60	665	3272	3.88
17,000	518	2570	3.05	562	2878	3.41	604	3176	3.77	645	3474	4.12	681	3736	4.43
17,500	531	2781	3.30	573	3097	3.67	614	3404	4.04	654	3710	4.40	691	3990	4.73
18,000	543	3001	3.56	584	3325	3.94	625	3640	4.32	664	3955	4.69	700	4252	5.04
19,000	568	3474	4.12	607	3815	4.53	646	4147	4.92	684	4488	5.32	720	4820	5.72
19,500	580	3728	4.42	619	4077	4.84	657	4418	5.24	693	4767	5.66	729	5107	6.06

AIRFLOW (CFM)	AVAILABLE EXTERNAL STATIC PRESSURE (in. wg)														
	1.2			1.4			1.6			1.8			2.0		
	RPM	WATTS	BHP	RPM	WATTS	BHP	RPM	WATTS	BHP	RPM	WATTS	BHP	RPM	WATTS	BHP
12,000	654	2042	2.42	700	2262	2.68	—	—	—	—	—	—	—	—	—
12,500	657	2183	2.59	702	2403	2.85	745	2640	3.13	—	—	—	—	—	—
13,000	661	2341	2.78	704	2561	3.04	746	2790	3.31	—	—	—	—	—	—
13,500	668	2517	2.99	709	2737	3.25	750	2974	3.53	791	3220	3.82	—	—	—
14,000	673	2693	3.19	713	2913	3.46	753	3150	3.74	792	3395	4.03	—	—	—
14,500	680	2886	3.42	719	3115	3.69	758	3351	3.98	796	3605	4.28	834	3859	4.33
15,000	686	3079	3.65	724	3316	3.93	762	3553	4.21	799	3806	4.52	836	4069	4.57
16,000	702	3518	4.17	739	3771	4.47	774	4016	4.76	810	4278	5.08	844	4540	5.11
17,000	717	3990	4.73	752	4252	5.04	786	4514	5.36	820	4785	5.68	853	5055	5.70
17,500	726	4252	5.04	760	4523	5.37	794	4793	5.69	827	5064	6.01	859	5353	6.02
18,000	735	4523	5.37	768	4802	5.70	801	5072	6.02	833	5371	6.37	865	5662	6.37
19,000	753	5107	6.06	785	5415	6.42	816	5707	6.77	848	5998	7.12	878	6298	7.09
19,500	762	5433	6.45	794	5733	6.80	825	6033	7.16	855	6263	7.51	885	6568	7.48

AIRFLOW (CFM)	AVAILABLE EXTERNAL STATIC PRESSURE (in. wg)														
	2.2			2.4			2.6			2.8			3.0		
	RPM	WATTS	BHP	RPM	WATTS	BHP	RPM	WATTS	BHP	RPM	WATTS	BHP	RPM	WATTS	BHP
12,000	—	—	—	—	—	—	—	—	—	—	—	—	—	—	—
12,500	—	—	—	—	—	—	—	—	—	—	—	—	—	—	—
13,000	—	—	—	—	—	—	—	—	—	—	—	—	—	—	—
13,500	—	—	—	—	—	—	—	—	—	—	—	—	—	—	—
14,000	—	—	—	—	—	—	—	—	—	—	—	—	—	—	—
14,500	871	4130	4.90	—	—	—	—	—	—	—	—	—	—	—	—
15,000	872	4340	5.15	—	—	—	—	—	—	—	—	—	—	—	—
16,000	879	4811	5.71	913	5099	6.05	947	5415	6.42	980	5724	6.79	—	—	—
17,000	886	5353	6.35	919	5645	6.70	951	5945	7.05	983	6254	7.42	1015	6507	7.81
17,500	891	5645	6.70	923	5936	7.04	955	6245	7.41	986	6481	7.78	1017	6795	8.15
18,000	897	5945	7.05	928	6245	7.41	959	6481	7.78	989	6786	8.14	1020	7109	8.53
19,000	908	6525	7.83	938	6830	8.19	968	7135	8.56	997	7449	8.94	1027	7772	9.32
19,500	915	6865	8.24	944	7170	8.60	973	7484	8.98	1002	7807	9.37	1031	8129	9.75

LEGEND

**Bhp** — Brake Horsepower Input to Supply Fan  
**Watts** — Input Power to Supply Fan Motor

NOTES:

- Unit is available with the following motor and drive combinations: 7.5, 10, 15 hp standard drive; 7.5, 10, 15 hp medium-static drive; 7.5, 10, 15 hp high-static drive.  
 For 7.5 hp standard drives, the drive range is 780 to 960 rpm.  
 For 10, 15 hp standard and 7.5 hp medium-static drives, the drive range is 805 to 991 rpm.  
 For 10, 15 hp medium-static and 7.5 hp high-static drives the drive range is 960 to 1146 rpm.  
 For 10, 15 hp high-static drives the drive range is 1119 to 1335 rpm.

- Italics* indicates field-supplied drive required.
- Do not operate in shaded area.
- Static pressure losses must be applied to external static pressure before entering the fan performance table.
- Interpolation is permitted; extrapolation is not.
- Fan performance is based on filter, unit casing, and wet coil losses.
- Bhp values are *per fan*. Watts values are *per motor*. Unit has 2 supply fans and 2 motors.

Table 22 — Fan Performance — 50BVT,V054

AIRFLOW (CFM)	AVAILABLE EXTERNAL STATIC PRESSURE (in. wg)														
	0.2			0.4			0.6			0.8			1.0		
	RPM	WATTS	BHP	RPM	WATTS	BHP	RPM	WATTS	BHP	RPM	WATTS	BHP	RPM	WATTS	BHP
15,000	489	1953	2.32	537	2227	2.64	582	2473	2.93	623	2711	3.22	663	2939	3.49
16,000	513	2315	2.75	559	2596	3.08	603	2878	3.41	642	3132	3.72	680	3369	4.00
17,000	540	2728	3.24	583	3027	3.59	624	3325	3.94	663	3605	4.28	699	3868	4.59
18,000	564	3167	3.76	605	3483	4.13	645	3798	4.51	683	4112	4.88	718	4392	5.21
18,500	578	3413	4.05	618	3745	4.44	657	4069	4.83	694	4392	5.21	729	4680	5.55
19,000	590	3666	4.35	629	3999	4.74	667	4331	5.14	704	4671	5.54	738	4977	5.90
19,500	604	3938	4.67	642	4278	5.08	679	4628	5.49	715	4968	5.89	749	5299	6.29
20,000	617	4226	5.01	655	4584	5.44	691	4933	5.85	726	5282	6.27	761	5654	6.71
20,500	629	4505	5.34	665	4872	5.78	701	5238	6.21	736	5618	6.67	770	5980	7.09
21,000	643	4820	5.72	678	5194	6.16	713	5583	6.62	747	5963	7.07	780	6263	7.51
22,000	669	5503	6.53	704	5901	7.00	737	6298	7.47	770	6612	7.93	802	7005	8.40
23,000	696	6236	7.40	729	6577	7.89	761	6987	8.38	792	7388	8.86	823	7798	9.36
24,000	722	6952	8.34	754	7380	8.85	784	7798	9.36	815	8225	9.87	845	8510	10.38

AIRFLOW (CFM)	AVAILABLE EXTERNAL STATIC PRESSURE (in. wg)														
	1.2			1.4			1.6			1.8			2.0		
	RPM	WATTS	BHP	RPM	WATTS	BHP	RPM	WATTS	BHP	RPM	WATTS	BHP	RPM	WATTS	BHP
15,000	701	3167	3.76	739	3413	4.05	777	3658	4.34	814	3,911	4.64	850	4,174	4.95
16,000	717	3623	4.30	753	3868	4.59	789	4121	4.89	824	4,383	5.20	858	4,654	5.52
17,000	734	4121	4.89	769	4383	5.20	803	4645	5.51	837	4,915	5.83	870	5,194	6.16
18,000	751	4663	5.53	785	4933	5.85	817	5212	6.18	849	5,512	6.54	881	5,804	6.89
18,500	762	4968	5.89	794	5247	6.22	826	5548	6.58	857	5,839	6.93	889	6,130	7.27
19,000	771	5264	6.25	802	5574	6.61	834	5866	6.96	864	6,166	7.31	895	6,394	7.67
19,500	781	5618	6.67	812	5919	7.02	843	6219	7.38	873	6,446	7.73	903	6,743	8.09
20,000	792	5963	7.07	822	6272	7.44	852	6498	7.80	882	6,804	8.16	911	7,118	8.54
20,500	801	6307	7.48	831	6542	7.85	860	6856	8.23	890	7,170	8.60	918	7,484	8.98
21,000	812	6603	7.92	841	6926	8.31	870	7240	8.69	899	7,563	9.07	927	7,885	9.46
22,000	833	7388	8.86	861	7720	9.26	889	8051	9.66	917	8,253	10.07	944	8,578	10.46
23,000	854	8199	9.84	882	8441	10.30	909	8784	10.72	936	9,127	11.13	962	9,469	11.55
24,000	874	8921	10.88	903	9332	11.38	930	9701	11.83	955	10,060	12.27	981	10,420	12.71

LEGEND

**Bhp** — Brake Horsepower Input to Supply Fan  
**Watts** — Input Power to Supply Fan Motor

NOTES:

- Unit is available with the following motor and drive combinations: 7.5, 10, 15, 20 hp standard drive; 7.5, 10, 15, 20 hp medium-static drive; 7.5, 10, 15, 20 hp high-static drive.  
 For 7.5 hp standard drives, the drive range is 780 to 960 rpm. For 10, 15, 20 hp standard and 7.5 hp medium-static drives, the drive range is 805 to 991 rpm. For 10, 15, 20 hp medium-static and 7.5 hp high-static drives the drive range is 960 to 1146 rpm. For 10, 15, 20 hp high-static drives the drive range is 1119 to 1335 rpm.

- Italics** indicates field-supplied drive required.
-  Do not operate in shaded area.
- Static pressure losses must be applied to external static pressure before entering the fan performance table.
- Interpolation is permitted; extrapolation is not.
- Fan performance is based on filter, unit casing, and wet coil losses.
- Bhp values are *per fan*. Watts values are *per motor*. Unit has 2 supply fans and 2 motors.



Table 22 — Fan Performance — 50BVT,V054 (cont)

AIRFLOW (CFM)	AVAILABLE EXTERNAL STATIC PRESSURE (in. wg)														
	2.2			2.4			2.6			2.8			3.0		
	RPM	WATTS	BHP	RPM	WATTS	BHP	RPM	WATTS	BHP	RPM	WATTS	BHP	RPM	WATTS	BHP
15,000	886	4,444	5.27	922	4,741	5.62	958	5,046	5.99	993	5,380	6.38	—	—	—
16,000	893	4,924	5.84	927	5,212	6.18	961	5,539	6.57	994	5,857	6.95	—	—	—
17,000	903	5,495	6.52	935	5,795	6.87	967	6,095	7.23	999	6,341	7.61	1031	6,664	8.00
18,000	912	6,095	7.23	943	6,324	7.59	974	6,629	7.95	1005	6,943	8.33	1035	7,266	8.72
18,500	919	6,359	7.63	950	6,664	8.00	980	6,970	8.36	1010	7,284	8.74	1039	7,606	9.13
19,000	925	6,690	8.03	955	6,996	8.39	984	7,310	8.77	1013	7,624	9.15	1042	7,955	9.54
19,500	932	7,048	8.46	962	7,362	8.83	991	7,676	9.21	1019	7,999	9.60	1047	8,330	9.99
20,000	940	7,423	8.91	969	7,746	9.29	997	8,060	9.67	1025	8,253	10.07	1053	8,578	10.46
20,500	946	7,798	9.36	975	8,121	9.74	1003	8,304	10.13	1030	8,630	10.53	1057	8,955	10.92
21,000	955	8,199	9.84	982	8,390	10.23	1010	8,715	10.63	1037	9,041	11.03	1063	9,375	11.44
22,000	971	8,913	10.87	998	9,238	11.27	1024	9,572	11.68	1050	9,915	12.09	1076	10,257	12.51
23,000	988	9,812	11.97	1014	10,155	12.39	1040	10,506	12.82	1065	10,848	13.23	1090	11,207	13.67
24,000	1006	10,771	13.14	1031	11,130	13.58	1056	11,490	14.02	1080	11,849	14.45	1104	12,217	14.90

AIRFLOW (CFM)	AVAILABLE EXTERNAL STATIC PRESSURE (in. wg)														
	3.2			3.4			3.6			3.8			4.0		
	RPM	WATTS	BHP	RPM	WATTS	BHP	RPM	WATTS	BHP	RPM	WATTS	BHP	RPM	WATTS	BHP
15,000	—	—	—	—	—	—	—	—	—	—	—	—	—	—	—
16,000	—	—	—	—	—	—	—	—	—	—	—	—	—	—	—
17,000	1062	7,005	8.40	1093	7,353	8.82	—	—	—	—	—	—	—	—	—
18,000	1065	7,606	9.13	1095	7,946	9.53	—	—	—	—	—	—	—	—	—
18,500	1069	7,946	9.53	1098	8,286	9.94	1127	8,501	10.37	1156	8,861	10.81	—	—	—
19,000	1071	8,286	9.94	1100	8,493	10.36	1128	8,835	10.78	1157	9,195	11.22	1185	9,564	11.67
19,500	1076	8,518	10.39	1104	8,861	10.81	1132	9,212	11.24	1159	9,572	11.68	1187	9,932	12.12
20,000	1081	8,904	10.86	1108	9,247	11.28	1136	9,598	11.71	1163	9,958	12.15	1190	10,326	12.60
20,500	1084	9,298	11.34	1112	9,641	11.76	1138	9,992	12.19	1165	10,343	12.62	1191	10,711	13.07
21,000	1090	9,718	11.85	1116	10,060	12.27	1143	10,411	12.70	1169	10,771	13.14	1195	11,139	13.59
22,000	1102	10,608	12.94	1127	10,959	13.37	1153	11,319	13.81	1178	11,678	14.25	1203	12,046	14.69
23,000	1115	11,558	14.10	1139	11,918	14.54	1164	12,286	14.99	1188	12,653	15.43	1212	13,038	15.90
24,000	1128	12,585	15.35	1152	12,953	15.80	1176	13,329	16.26	1200	13,705	16.72	1223	14,090	17.19

LEGEND

**Bhp** — Brake Horsepower Input to Supply Fan  
**Watts** — Input Power to Supply Fan Motor

NOTES:

- Unit is available with the following motor and drive combinations: 7.5, 10, 15, 20 hp standard drive; 7.5, 10, 15, 20 hp medium-static drive; 7.5, 10, 15, 20 hp high-static drive.  
 For 7.5 hp standard drives, the drive range is 780 to 960 rpm. For 10, 15, 20 hp standard and 7.5 hp medium-static drives, the drive range is 805 to 991 rpm. For 10, 15, 20 hp medium-static and 7.5 hp high-static drives the drive range is 960 to 1146 rpm. For 10, 15, 20 hp high-static drives the drive range is 1119 to 1335 rpm.

- Italics* indicates field-supplied drive required.
- Do not operate in shaded area.
- Static pressure losses must be applied to external static pressure before entering the fan performance table.
- Interpolation is permitted; extrapolation is not.
- Fan performance is based on filter, unit casing, and wet coil losses.
- Bhp values are *per fan*. Watts values are *per motor*. Unit has 2 supply fans and 2 motors.

Table 23 — Fan Performance — 50BVT,V064

AIRFLOW (CFM)	AVAILABLE EXTERNAL STATIC PRESSURE (in. wg)														
	0.2			0.4			0.6			0.8			1.0		
	RPM	WATTS	BHP	RPM	WATTS	BHP	RPM	WATTS	BHP	RPM	WATTS	BHP	RPM	WATTS	BHP
18,000	564	3,167	3.76	605	3,483	4.13	645	3,798	4.51	683	4,112	4.88	718	4,392	5.21
19,000	590	3,666	4.35	629	3,999	4.74	667	4,331	5.14	704	4,671	5.54	738	4,977	5.90
20,000	617	4,226	5.01	655	4,584	5.44	691	4,933	5.85	726	5,282	6.27	761	5,654	6.71
21,000	643	4,820	5.72	678	5,194	6.16	713	5,583	6.62	747	5,963	7.07	780	6,263	7.51
22,000	669	5,503	6.53	704	5,901	7.00	737	6,298	7.47	770	6,612	7.93	802	7,005	8.40
23,000	696	6,236	7.40	729	6,577	7.89	761	6,987	8.38	792	7,388	8.86	823	7,798	9.36
24,000	722	6,952	8.34	754	7,380	8.85	784	7,798	9.36	815	8,225	9.87	845	8,510	10.38
25,000	750	7,816	9.38	780	8,260	9.91	810	8,561	10.44	839	8,990	10.97	868	9,427	11.50
26,000	777	8,595	10.49	806	9,050	11.04	835	9,504	11.59	863	9,949	12.14	891	10,403	12.69
27,000	804	9,572	11.68	832	10,043	12.25	860	10,514	12.83	887	10,985	13.40	914	11,447	13.96
28,000	832	10,634	12.97	859	11,122	13.57	886	11,610	14.16	912	12,097	14.76	938	12,585	15.35
29,000	859	11,747	14.33	885	12,251	14.94	911	12,756	15.56	936	13,260	16.18	962	13,765	16.79

AIRFLOW (CFM)	AVAILABLE EXTERNAL STATIC PRESSURE (in. wg)														
	1.2			1.4			1.6			1.8			2.0		
	RPM	WATTS	BHP	RPM	WATTS	BHP	RPM	WATTS	BHP	RPM	WATTS	BHP	RPM	WATTS	BHP
18,000	751	4,663	5.53	785	4,933	5.85	817	5,212	6.18	849	5,512	6.54	881	5,804	6.89
19,000	771	5,264	6.25	802	5,574	6.61	834	5,866	6.96	864	6,166	7.31	895	6,394	7.67
20,000	792	5,963	7.07	822	6,272	7.44	852	6,498	7.80	882	6,804	8.16	911	7,118	8.54
21,000	812	6,603	7.92	841	6,926	8.31	870	7,240	8.69	899	7,563	9.07	927	7,885	9.46
22,000	833	7,388	8.86	861	7,720	9.26	889	8,051	9.66	917	8,253	10.07	944	8,578	10.46
23,000	854	8,199	9.84	882	8,441	10.30	909	8,784	10.72	936	9,127	11.13	962	9,469	11.55
24,000	874	8,921	10.88	903	9,332	11.38	930	9,701	11.83	955	10,060	12.27	981	10,420	12.71
25,000	896	9,855	12.02	924	10,283	12.54	951	10,702	13.06	976	11,079	13.51	1001	11,456	13.97
26,000	919	10,857	13.24	945	11,302	13.79	972	11,747	14.33	997	12,166	14.84	1022	12,551	15.31
27,000	941	11,918	14.54	967	12,380	15.10	993	12,850	15.67	1018	13,303	16.23	1042	13,722	16.74
28,000	964	13,064	15.94	990	13,551	16.53	1015	14,030	17.11	1040	14,517	17.71	1064	14,979	18.27
29,000	987	14,269	17.41	1011	14,765	18.01	1036	15,261	18.62	1060	15,765	19.23	1084	16,260	19.83

LEGEND

**Bhp** — Brake Horsepower Input to Supply Fan  
**Watts** — Input Power to Supply Fan Motor

NOTES:

- Unit is available with the following motor and drive combinations: 7.5, 10, 15, 20 hp standard drive; 7.5, 10, 15, 20 hp medium-static drive; 7.5, 10, 15, 20 hp high-static drive.  
 For 7.5 hp standard drives, the drive range is 780 to 960 rpm. For 10, 15, 20 hp standard and 7.5 hp medium-static drives, the drive range is 805 to 991 rpm. For 10, 15, 20 hp medium-static and 7.5 hp high-static drives the drive range is 960 to 1146 rpm. For 10, 15, 20 hp high-static drives the drive range is 1119 to 1335 rpm.

- Italics* indicates field-supplied drive required.
-  Do not operate in shaded area.
- Static pressure losses must be applied to external static pressure before entering the fan performance table.
- Interpolation is permitted; extrapolation is not.
- Fan performance is based on filter, unit casing, and wet coil losses.
- Bhp values are *per fan*. Watts values are *per motor*. Unit has 2 supply fans and 2 motors.

**Table 23 — Fan Performance — 50BVT,V064 (cont)**

AIRFLOW (CFM)	AVAILABLE EXTERNAL STATIC PRESSURE (in. wg)														
	2.2			2.4			2.6			2.8			3.0		
	RPM	WATTS	BHP	RPM	WATTS	BHP	RPM	WATTS	BHP	RPM	WATTS	BHP	RPM	WATTS	BHP
18,000	912	6,095	7.23	943	6,324	7.59	974	6,629	7.95	1005	6,943	8.33	1035	7,266	8.72
19,000	925	6,690	8.03	955	6,996	8.39	984	7,310	8.77	1013	7,624	9.15	1042	7,955	9.54
20,000	940	7,423	8.91	969	7,746	9.29	997	8,060	9.67	1025	8,253	10.07	1053	8,578	10.46
21,000	955	8,199	9.84	982	8,390	10.23	1010	8,715	10.63	1037	9,041	11.03	1063	9,375	11.44
22,000	971	8,913	10.87	998	9,238	11.27	1024	9,572	11.68	1050	9,915	12.09	1076	10,257	12.51
23,000	988	9,812	11.97	1014	10,155	12.39	1040	10,506	12.82	1065	10,848	13.23	1090	11,207	13.67
24,000	1006	10,771	13.14	1031	11,130	13.58	1056	11,490	14.02	1080	11,849	14.45	1104	12,217	14.90
25,000	1025	11,824	14.42	1050	12,191	14.87	1074	12,568	15.33	1097	12,944	15.79	1121	13,320	16.25
26,000	1045	12,936	15.78	1069	13,320	16.25	1092	13,714	16.73	1115	14,098	17.20	1138	14,492	17.68
27,000	1065	14,124	17.23	1088	14,526	17.72	1110	14,927	18.21	1133	15,329	18.70	1155	15,731	19.19
28,000	1086	15,397	18.78	1108	15,816	19.29	1131	16,235	19.80	—	—	—	—	—	—
29,000	—	—	—	—	—	—	—	—	—	—	—	—	—	—	—

AIRFLOW (CFM)	AVAILABLE EXTERNAL STATIC PRESSURE (in. wg)														
	3.2			3.4			3.6			3.8			4.0		
	RPM	WATTS	BHP	RPM	WATTS	BHP	RPM	WATTS	BHP	RPM	WATTS	BHP	RPM	WATTS	BHP
18,000	1065	7,606	9.13	1095	7,946	9.53	—	—	—	—	—	—	—	—	—
19,000	1071	8,286	9.94	1100	8,493	10.36	1128	8,835	10.78	1157	9,195	11.22	1185	9,564	11.67
20,000	1081	8,904	10.86	1108	9,247	11.28	1136	9,598	11.71	1163	9,958	12.15	1190	10,326	12.60
21,000	1090	9,718	11.85	1116	10,060	12.27	1143	10,411	12.70	1169	10,771	13.14	1195	11,139	13.59
22,000	1102	10,608	12.94	1127	10,959	13.37	1153	11,319	13.81	1178	11,678	14.25	1203	12,046	14.69
23,000	1115	11,558	14.10	1139	11,918	14.54	1164	12,286	14.99	1188	12,653	15.43	1212	13,038	15.90
24,000	1128	12,585	15.35	1152	12,953	15.80	1176	13,329	16.26	1200	13,705	16.72	1223	14,090	17.19
25,000	1144	13,697	16.71	1167	14,073	17.17	1190	14,457	17.64	1213	14,850	18.12	1236	15,235	18.58
26,000	1160	14,876	18.15	1183	15,269	18.63	1205	15,662	19.11	1227	16,064	19.60	—	—	—
27,000	1177	16,132	19.68	—	—	—	—	—	—	—	—	—	—	—	—
28,000	—	—	—	—	—	—	—	—	—	—	—	—	—	—	—
29,000	—	—	—	—	—	—	—	—	—	—	—	—	—	—	—

**LEGEND**

**Bhp** — Brake Horsepower Input to Supply Fan  
**Watts** — Input Power to Supply Fan Motor

**NOTES:**

- Unit is available with the following motor and drive combinations: 7.5, 10, 15, 20 hp standard drive; 7.5, 10, 15, 20 hp medium-static drive; 7.5, 10, 15, 20 hp high-static drive.  
 For 7.5 hp standard drives, the drive range is 780 to 960 rpm. For 10, 15, 20 hp standard and 7.5 hp medium-static drives, the drive range is 805 to 991 rpm. For 10, 15, 20 hp medium-static and 7.5 hp high-static drives the drive range is 960 to

1146 rpm. For 10, 15, 20 hp high-static drives the drive range is 1119 to 1335 rpm.

- Italics** indicates field-supplied drive required.
- Do not operate in shaded area.
- Static pressure losses must be applied to external static pressure before entering the fan performance table.
- Interpolation is permitted; extrapolation is not.
- Fan performance is based on filter, unit casing, and wet coil losses.
- Bhp values are *per fan*. Watts values are *per motor*. Unit has 2 supply fans and 2 motors.

## CONTROLS

### Unit Protection Module (UPM)

**GENERAL DESCRIPTION** — The Unit Protection Module (UPM) as shown in Fig. 17 is a printed circuit board (PCB) that interfaces with the thermostat for constant volume units or the digital direct controller.

The main purpose of this device is to protect the compressors by monitoring the different states of switches and sensors of each refrigerant circuit. This device provides time delays and protects the unit against freezing of the water and refrigerant heat exchangers as well as condensate overflow when the appropriate sensors are installed.

**FEATURES AND SAFETIES** — Alarm output is Normally Open (NO) dry contact. If 24 vac output is needed, R must be wired to the ALR-COM terminal; 24 vac will be available on the ALR-OUT terminal when the unit is in alarm condition. If pulse is selected, the alarm output will be pulsed.

**Power Random Start-Up** — This feature prevents multiple units sharing same electrical circuit or network from starting at the same time. It assures that units sharing the same electrical circuit do not demand high inrush currents simultaneously when starting back up after a power failure.

If the controller has been completely powered down for more than 28 milliseconds, a random delay is initiated. If the controller is set to normal operation (test switch set to NO), then typically the unit will start within the time range of 270 to 300 seconds.

In order for the random sequence to initiate the unit power must be removed completely.

**IMPORTANT:** If the board is set to “TEST” mode through the “TEST” DIP switch, SW1 delay will be 10 seconds.

**Anti-Short Cycle Delay** — This feature protects the compressor short cycling if the Y call is set and removed. The anti-short cycle delay is 300 seconds on break during normal operation.

**NOTE:** If the board is set to test mode through the “TEST” DIP switch, the delay will be 5 seconds.

**High and Low Pressure Protection** — The UPM monitors the state of the high and low pressure switch inputs of each refrigerant circuit, HP1, LP1, HP2, and LP2. These switches must be closed for the controller to energize the compressor output (CC1 and CC2). The CC output will only be energized when the switches are closed and the anti-short cycle (and/or random start-up when applicable) has expired.

**High Pressure Protection** — If the HP1 or HP2 switches are open upon a Y1 or Y2 call, the UPM will not energize the respective CC1 or CC2 outputs; the corresponding compressor will remain off, the fault LED will flash 1 time for the HP1 and 3 times for HP2, and the alarm contact will remain off.

If a compressor is running in normal mode on a Y call (Y1 or Y2 or both) and the high pressure switch opens, the UPM will shut down the compressor output and will keep it off until the switch closes and the anti-short cycle has expired. The

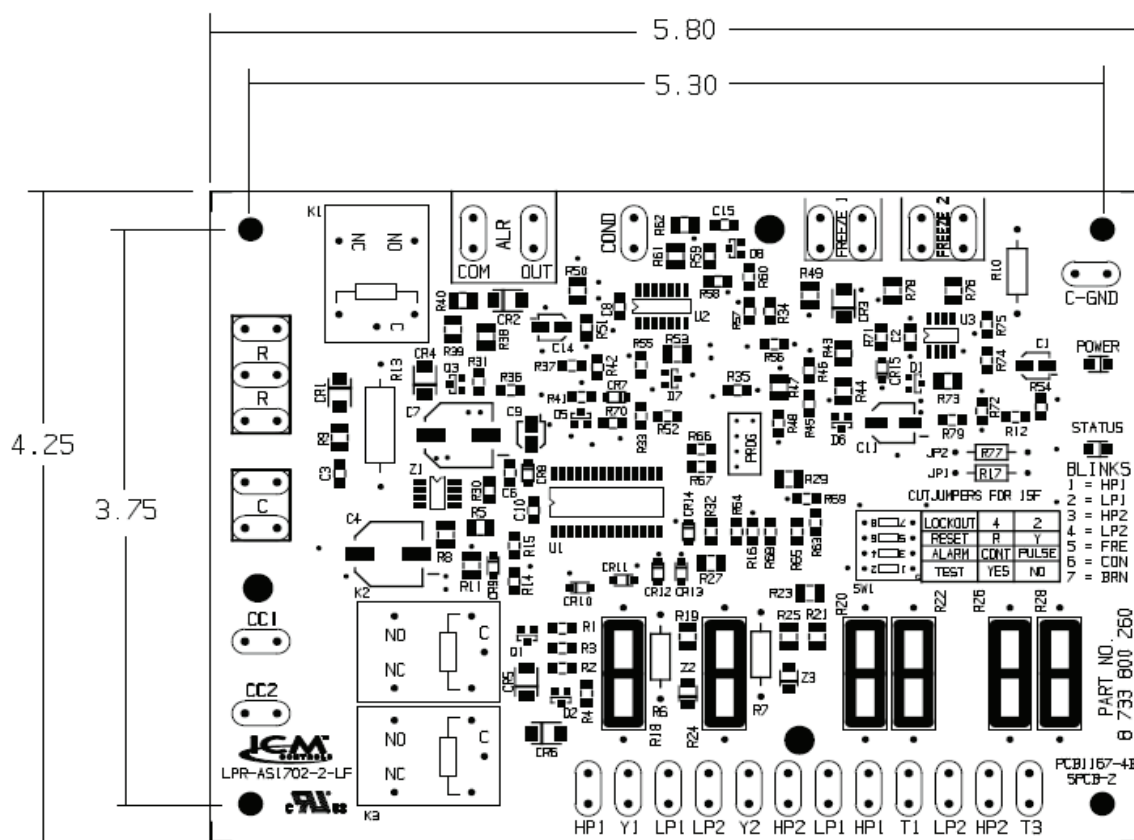

Dimensions are in inches.

**Fig. 17 — Two-Stage Unit Protection Module**

controller will keep track of the number of times the switch opens; if, within a 1-hour period, the switch opens the number of times set via the DIP switch, the controller will shut down the compressor and perform a hard lockout condition. Under this condition the alarm contact will be energized.

The UPM allows the user to configure the counts that the HP will be allowed to open within 1 hour before the UPM performs a hard lockout on the compressor. The user can select either two or four times by changing switch 4 on the DIP switch SW1 on the UPM board.

**Low Pressure Protection** — If the LP1 or LP2 switches are open upon a Y1 or Y2 call (Y1 or Y2 or both) the UPM will not energize the CC1 or CC2 outputs; the corresponding compressor will remain off, the fault LED will flash two times for the LP1 and 4 times for the LP2, and the alarm contact will remain off.

If the compressor is running in normal mode on a Y call (Y1 or Y2 or both) and the low pressure switch opens, the UPM will keep the compressor running for 2 minutes. If the condition remains after this period of time, the compressor will shut down and the UPM will start a soft lockout. The UPM will flash 2 times for the LP1 and 4 times for the LP2 and the alarm contact will remain off.

If the switches close, the UPM will start the compressor after the anti-short cycle has expired and UPM will energize the compressor output.

**IMPORTANT:** To exit the hard lockout the controller must be reset from the Y or R terminal by removing the power from the selected terminal. The user can choose which will be the reset point via the DIP switch SW1.

**Ground** — The UPM controller takes its ground reference from the unit chassis which is connected to the controller via the C-GND spade terminal.

**DIP Switch Settings** — The DIP switch is used to configure most of the available features of the UPM as follows:

- Alarm mode, Constant or Pulse
- Reset mode, Y signal or R signal
- Lockout mode, 2 or 4 strikes
- Test mode, Normal or Test operation

The settings shown in Fig. 18 are factory default. The unit wiring diagram is the ultimate guide for factory DIP switch default settings.

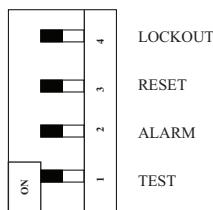

**Fig. 18 — Dip Switch Settings**

The following table is available on the UPM board as well and it depicts the switch position and its associated functionality (Table 24).

**Table 24 — UPM Dip Switch Configuration**

4	LOCKOUT	4	2
3	RESET	R	Y
2	ALARM	CONT	PULSE
1	TEST	YES	NO

**Selectable Alarm Mode** — The UPM controller can be configured to have either a constant signal or a pulse.

If constant (CONT) is selected the UPM will provide a closed contact until the alarm is cleared.

If pulsed (PULSE) is selected the UPM will sequence the alarm contact with the fault LED flashes.

**Freeze Protection** — The default setting for the freeze limit trip is 30 F; this can be changed to 15 F by cutting the R17 for Compressor 1 and R77 for Compressor 2 resistor located on top of the DIP switch SW1. The UPM controller will constantly monitor the refrigerant temperature with the sensor mounted close to the condensing water coil between the thermal expansion valve and water coil as shown in Fig. 19.

If temperature drops below or remains at the freeze limit trip for 30 seconds, the controller will shut the compressor down and enter into a soft lockout condition. Both the status LED and the Alarm contact will be active. The LED will flash 5 times the code associated with this alarm condition.

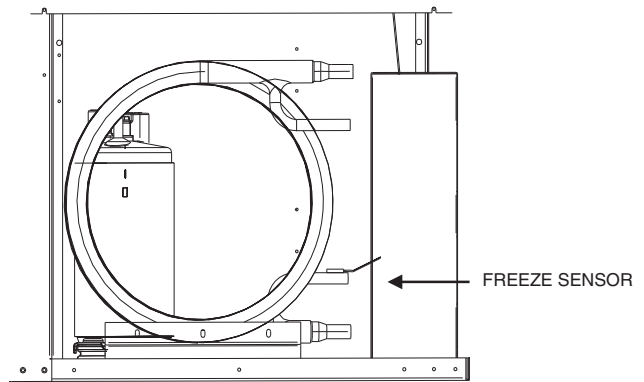

**Fig. 19 — Freeze Sensor Location**

**Brownout Protection** — The UPM controller will constantly monitor the power supply. If the nominal voltage drops below 25% of its value (18 VAC approximately), the unit will enter brownout protection mode. The compressor CC outputs will be de-energized and the unit will enter the soft lockout mode. The controller will **not** monitor the power supply during the first **500 milliseconds** of compressor start-up to avoid noise and false alarms. Once the UPM detects a brownout condition, its fault LED will flash 7 times as error code indication.

**Condensation Overflow** — The UPM controller continuously monitors the drain pan for high condensate water level. To do so it utilizes a sensor which, when condensate sensor option is present, identifies an alarm condition when the sensor's impedance drops below  $230,000 \pm 15\%$ . Once the UPM senses this resistance value, it enters into a hard lockout and reports the corresponding code via its status LED (6 flashes). To exit the hard lockout, water has to return to its normal level and UPM has to be reset by removing the power from the Y terminal (R if set on the DIP switch). The compressors will be turned on after anti-short cycle expires.

**Sequence of Operation, CV Units — 50BVC,Q,T,V** — The following sequence of operation applies to constant volume units.

Cooling is initiated when the set point in the remote thermostat is not met (space temperature is higher than set point). The unit sequence of operation is as follows:

Contact closure at the ‘G’ terminal will provide power to the supply fan contactor energizing the supply fan. The supply fan will be off during unoccupied schedule, depending upon the features of the thermostat used.

The ‘O’ terminal energizes the reversing valve (heat pump units only). Typically ‘Y1’ will also be energized at this time for cooling operation. The second stage of cooling ‘Y2’ will be initialized after a minimum run time and there is a differential from set point plus a deadband or a proportional plus integral calculation based upon demand and length of time space temperature is greater than set point.

Additional assurance is provided by a delay on make timer in the second-stage compressor contactor circuit to avoid dual compressor in-rush starting current.

Heating mode (heat pump models only) follows the same sequence as above except that the reversing valve is not energized.

The UPM sequence of operation illustrated in Fig. 20 applies for both refrigerant circuits. The second compressor is energized 10 seconds after the first if both Y1 and Y2 signals are applied simultaneously.

**WATER ECONOMIZER COOLING** — The unit diverts condenser inlet waterflow through an optional economizer coil to pre-cool evaporator entering airflow. If the entering water temperature is colder than the setting on the aquastat and the return-air temperature is warmer than the setting on the return air thermostat, the two-position diverting valve will direct water to the economizer coil.

Economizer water flow is in series with the condensers allowing compressor operation while the economizer is operating.

**Y CALL (COOLING OR HEATING)** — The UPM will energize the compressor’s output (CC) in an event of a ‘Y’ Call from a thermostat or controller (after the random start-up and/or the anti-short cycle delays have elapsed). The Y input terminal must be energized with a 24 VAC signal.

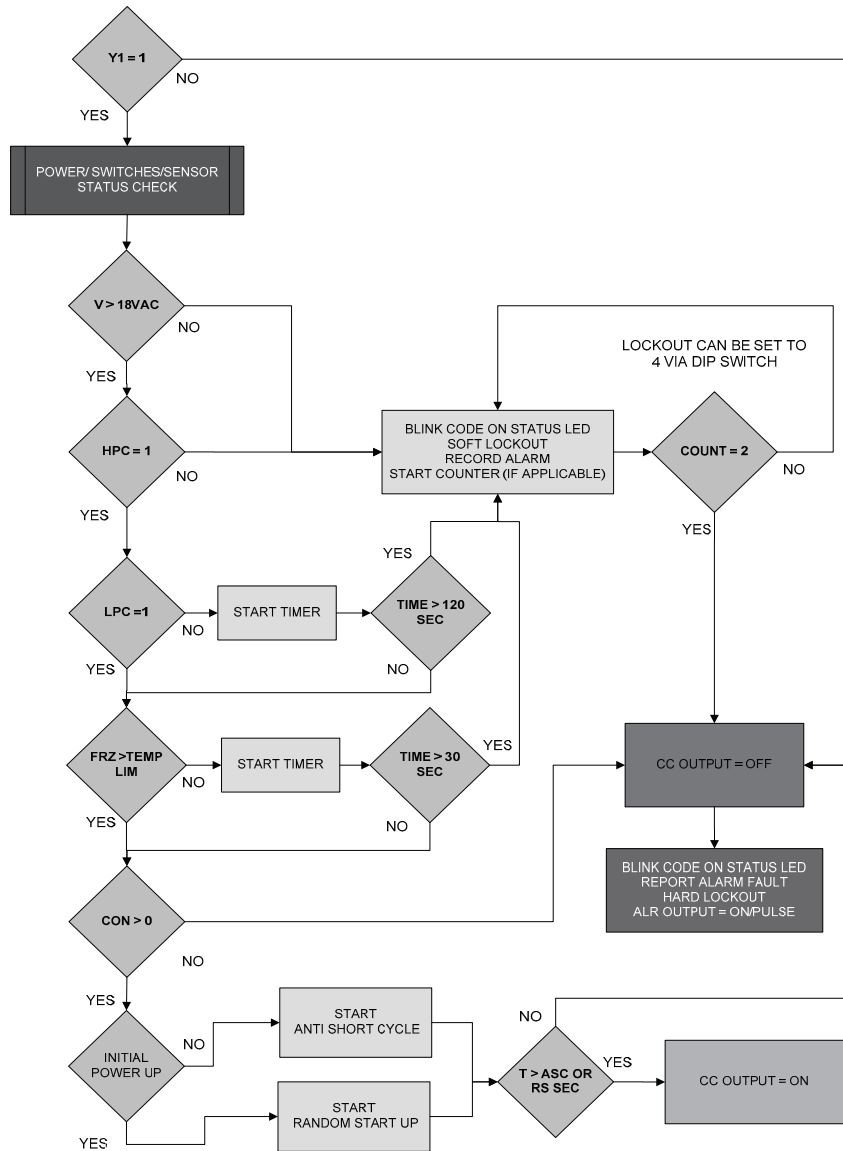

**Fig. 20 — UPM Sequence of Operation (SOO) Flow Chart**

## I/O Flex 6126 Controller Specifications, VAV Units Only — 50BVJ,W

**POWER** — 24 vac  $\pm$  10%, 50 to 60 Hz, 20 va power consumption (26 va with BACview tool attached):

26 Vdc (25 V min, 30 V max)

Single Class II 100 va or less

**PHYSICAL** — Rugged aluminum housing, removable screw terminals with custom silk-screening available.

**ENVIRONMENTAL OPERATING RANGE** — -20 to 140 F (-29 to 60 C), 10 to 95% relative humidity, non-condensing.

**DIGITAL OUTPUTS** — 6 binary outputs relay contacts rated at 5A max at 250 VAC. Configured normally open or normally closed.

**ANALOG OUTPUTS** — 6 analog outputs, 1 and 2 are configurable for 0 to 10V or 0 to 20mA; 3 through 6 are 0 to 10V only.

**UNIVERSAL INPUTS** — 12 universal inputs are used to monitor input from various sensors. These universal inputs can be set for one of three different sensor input types:

1. Voltage (0 to 10 V),
2. Temperature (resistance temperature detector or thermistor) or discrete contact, or
3. Current (0 to 20 mA).

Inputs 1 and 2 may be used for pulse counting.

**STANDARD COMMUNICATION PORTS** — Comm Port:

- P1: Communication with the ARC156 networks
- P2a: Configurable for EIA-232 or EIA-485 (2 wire or 4 wire). Network protocol selectable for BACnet (MS/TP or PTP), Modbus, N2, LonWorks SLTA, or modem.
- P2b: Configurable for LonWorks plug-in or Ethernet.

**RNET PORT** — Supports up to four RS Standard sensors and one RS Plus, RS Pro for averaging or high/low select control. The sensors can share the Rnet port with BACview.

**LOCAL ACCESS PORT** — For local communication with a laptop computer running virtual BACview.

**XNET PORT** — For communication with the I/O Flex EX8160 expander.

**BACNET\* SUPPORT** — Conforms to the Advanced Application Controller (B-AAC) Standard Device Profile as defined in ANSI/ASHRAE Standard 135-2004 (BACnet) Annex L.

**STATUS INDICATION** — Visual (LED) status of network communication, running, errors, power, transmit/receive for Port 1 and Port 2a and for each of the 12 outputs.

**BATTERY** — 10-year Lithium 3 v coin cell battery, CR2032, provides a minimum of 10,000 hours of data retention during power outages.

**PROTECTION** — Incoming power and network connections are protected by non-replaceable internal solid-state poly-switches that reset themselves when the condition that causes a fault returns to normal. The power, network, input, and output connections are also protected against voltage transient and surge events.

**LISTED BY** — UL-916 (PAZX), CUL-916 (PAZX7), FCC Part 15-Subpart B-Class A, CE EN50082-1997.

**WEIGHT** — 1lb, 3 oz (0.5 kg).

**OVERALL DIMENSIONS** — 5 in. (width) by 11<sup>3</sup>/<sub>4</sub> in. (height) by 2 in. (recommended panel depth). 127 mm (width) by 299 mm (height) by 51 mm (recommended panel depth).

**MOUNTING HOLE DIMENSIONS** — Four mounting holes, two above and below.

Width: 4 in. (102 mm)

Height: 11<sup>3</sup>/<sub>8</sub> in. (289 mm)

**Addressing the I/O Flex 6126 Controller** — The I/O Flex 6126 controller's two rotary switches determine the I/O Flex 6126 controller's MAC address when it is placed on a BACnet/ARC 156 or BACnet MS/TP network. The rotary switches define the MAC address portion of the device's BACnet address, which is composed of the network address and the MAC address. They also set the slave address on a Modbus or N2 network, when less than 100.

If the I/O Flex 6126 controller has been wired for power, when changing its address in the field the power switch must be cycled or the screw terminal connector from its power terminals labeled Gnd and Hot. The controller reads the address each time power is applied to it.

Using the rotary switches; set the controller's address. Set the Tens (10's) switch to the tens digit of the address, and set the Ones (1's) switch to the ones digit. See Fig. 21.

**EXAMPLE:** If the controller's address is 01, point the arrow on the Tens (10's) switch to 0 and the arrow on the Ones (1's) switch to 1.

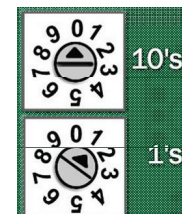

**Fig. 21 — Address Rotary Switch**

**NOTE:** The I/O Flex 6126 controller recognizes its address only after power has been cycled.

**Wiring Inputs and Outputs** — Refer to Table 25 for wiring inputs and outputs.

\*BACnet is a registered trademark of ASHRAE.

**Table 25 — Input Wiring Specifications**

INPUT	MAXIMUM LENGTH	MINIMUM GAGE	SHIELDING
0-5 VDC 0-10 VDC	1000 feet (305 meters)	26 AWG	Shielded
0-20 mA	3000 feet (914 meters)	26 AWG	Shielded or unshielded
Thermistor Dry contact Pulse counter	1000 feet (305 meters)	22 AWG	Shielded
RTD	100 feet (30 meters)	22 AWG	Shielded
ZS sensor BACview Equipment Touch	500 feet (152 meters)	18 AWG, 4 conductor if BACview is connected to the Rnet 22 AWG, 4 conductor if only RS room sensors are connected to the Rnet	Shielded or unshielded

**LEGEND**

- AWG** — American Wire Gage
- RTD** — Resistance Temperature Detector

**Input – I/O Flex 6126 Controller**

The I/O Flex 6126 controller has 12 inputs that accept the signal types described below. See Table 26.

**Table 26 — I/O Flex 6126 Controller Inputs**

INPUT	SIGNAL TYPE SUPPORTED	DESCRIPTION
All	Thermistor RTD 0-10 Vdc 4-20 mA	Type 2 (10 K ohm at 77° F). Input voltages should be from 0.489 VDC to 3.825 VDC for thermistors.
All	Dry contact	A 5 VDC wetting voltage detects contact position, resulting in a 0.5 mA maximum sense current when the contacts are closed.
UI-1, UI-2	0-20 mA Pulse input	The input impedance of the I/O Flex 6126 controller is approximately 1 Mohm.

**BINARY OUTPUTS** — The I/O Flex 6126 controller has 6 binary outputs that can be connected to a maximum of 24 VAC/VDC inputs. Each output is a dry contact rated at 1A, 24 V maximum and is normally open. To size output wiring, consider the following when field installing accessories:

- Total loop distance from the power supply to the controller, and then to the controlled device

**NOTE:** Include the total distance of actual wire. For 2-conductor wires, this is twice the cable length.

- Acceptable voltage drop in the wire from the controller to the controlled device
- Resistance (ohms) of the chosen wire gage
- Maximum current (amps) the controlled device requires to operate

**ANALOG OUTPUTS** — The I/O Flex 6126 controller has 6 analog outputs that support voltage or current devices. The controlled device must share the same ground as the controller and have the following input impedance:

- 0 to 10 VDC min 500 ohms
- 0 to 20 mA min 800 ohms

See Table 27 for a detailed list of standard inputs and outputs.

**TO WIRE FIELD ACCESSORIES ON THE I/O FLEX 6126 CONTROLLER OR I/O FLEX EX8160 EXPANDER —**

1. Turn off power to the I/O Flex 6126 controller.
2. Connect the input or output wiring to the screw terminals on the controller:
  - Connect the shield wire to the GND terminal with the ground wire.
  - For a loop-powered 4 to 20 mA sensor, wire the sensor's positive terminal to the + terminal on the I/O Flex 6126 controller's Aux Power Out Port. Wire the sensor's negative terminal to an input's + terminal.
3. Set the appropriate jumpers on the I/O Flex 6126 controller.

USE	TYPE	DESCRIPTION
Any Input	Thermistor Dry Contact 0-5 Vdc 0-10 Vdc 0-20 mA RTD	Set each input's Universal Input Mode Select jumper to the type of signal the input will receive
Aux Power Out Port	Loop-powered 4-20 mA	Set the Select jumper to +5V or +24V as required by the sensor.

4. Connect the binary output wiring to the screw terminals on the I/O Flex 6126 controller and to the controlled device (Fig. 22).

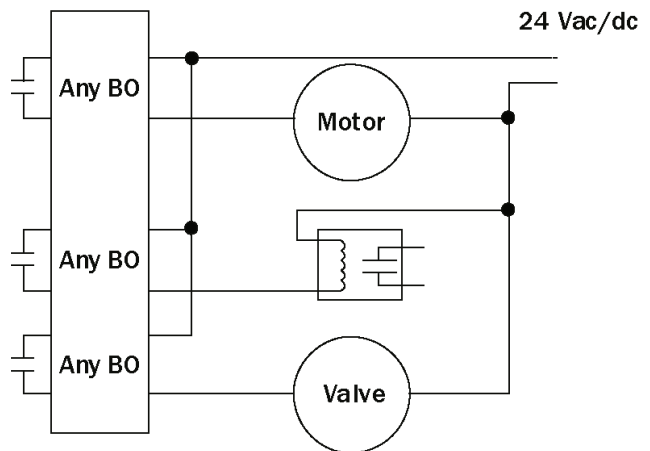

**Fig. 22 — Binary Output Diagram**



**Table 27 — 50BVJ,W Standard I/O Table**

INPUT /OUTPUT TYPE	TYPICAL DEVICE	TYPE OF I/O	CONNECTION PIN NUMBERS	I/O TYPE CONFIG
I/O FLEX 6126 Controller				
Inputs				
Occupancy Override *	Dry Contact (N.O)	UI (0-10 V, RTD Therm/Dry, 0-20 mA)	UI-12 - 19 & 20	DI
Duct Static Pressure Sensor	0-5 VDC	UI (0-10 V, RTD Therm/Dry, 0-20 mA)	UI-11 -17 & 18	AI
Compressor Status (compressor 4)	IEM 2	UI (0-10 V, RTD Therm/Dry, 0-20 mA)	UI-10 - 16 & 17	DI
Compressor Status (Compressors 1-3)	IEM 1	UI (0-10 V, RTD Therm/Dry, 0-20 mA)	UI-09 - 14 & 15	DI
Return Air Sensors	10K Type II	UI (0-10 V, RTD Therm/Dry, 0-20 mA)	UI-08 - 13 & 14	AI
Entering Water Temperature (required for Economizer)	10K Type II	UI (0-10 V, RTD Therm/Dry, 0-20 mA)	UI-07 - 11 & 12	AI
Supply Air Temperature Sensor	10K Type II	UI (0-10 V, RTD Therm/Dry, 0-20 mA)	UI-06 - 10 & 11	AI
Relative Humidity Sensor*†	0-5 VDC	UI (0-10 V, RTD Therm/Dry, 0-20 mA)	UI-05 - 8 & 9	AI
CO <sub>2</sub> Sensor (Required for demand control ventilation)*	0-5 VDC	UI (0-10 V, RTD Therm/Dry, 0-20 mA)	UI-04 - 7 & 8	AI
Leaving Water Temperature Sensor (standard)	10K Type II	UI (0-10 V, RTD Therm/Dry, 0-20 mA)	UI-03 - 5 & 6	AI
UPM II - Compressors 2 & 4		UI Pulse Counting (0-20 mA)	UI-02 - 2 & 4	DI - pulse
UPM II - Compressors 1 & 3		UI Pulse Counting (0-20 mA)	UI-01 - 2 & 3	DI - pulse
Outputs				
Open		AO (0-10 V)	AO-6 - 11 & 12	AO
Open		AO (0-10 V)	AO-5 - 9 & 10	AO
Return Fan Speed (VFD Drive Terminal Strip)*	ABB ACH550-UH	AO (0-10 V)	AO-4 - 7 & 8	AO
Open		AO (0-10 V)	AO-3 - 5 & 6	AO
Modulating Hot Gas Re-heat Valves		AO (4-20mA/0-10 V)	AO-2 - 3 & 4	AO
Fan Speed - (VFD Drive Terminal Strip AI-1)	ABB ACH550-UH	AO (4-20mA/0-10 V)	AO-1 - 1 & 2	AO
Compressor Stage 4 Command (Y4)		BO (Relay 5A at 250Vac)	BO-6 - 16-18	BO
Compressor Stage 3 Command (Y3)		BO (Relay 5A at 250Vac)	BO-5 - 13-15	BO
Compressor Stage 2 Command (Y2)		BO (Relay 5A at 250Vac)	BO-4 - 10-12	BO
Compressor Stage 1 Command (Y1)		BO (Relay 5A at 250Vac)	BO-3 - 7-9	BO
Open		BO (Relay 5A at 250Vac)	BO-2 - 4-6	BO
Supply Fan Enable signal (VFD Drive Terminal Strip)	ABB ACH550-UH	BO (Relay 5A at 250Vac)	BO-1 - 1-3	BO
Xnet Remote Expansion	I/O Flex EX8160 expander	I/O Expansion Board	Xnet	Comm-Port

**LEGEND**

- AI** — Analog Input
- AO** — Analog Output
- BI** — Digital Input
- BO** — Digital Output
- UI** — Universal Input

\* Inputs and outputs are optional. Sensors not provided. 50BV units do not contain a return fan; return fan control is available for return fan separate from 50BV unit.

† Read-only points. No effect on Sequence of Operation.

NOTE: Transformer's common terminals are tied together.

**Table 27 — 50BVJ,W Standard I/O Table (cont)**

INPUT /OUTPUT TYPE	TYPICAL DEVICE	TYPE OF I/O	CONNECTION PIN NUMBERS	I/O TYPE CONFIG
I/O FLEX EX8160 Expander				
Inputs				
Open		UI (0-5 V, Therm Dry)	IN-16 - 15 & 16	UI
Open		UI (0-5 V, Therm Dry)	IN-15 - 13 & 14	UI
Open		UI (0-5 V, Therm Dry)	IN-14 - 11 & 12	UI
Open		UI (0-5 V, Therm Dry)	IN-13 - 9 & 10	UI
Open		UI (0-5 V, Therm Dry)	IN-16 - 15 & 16	UI
Condenser Water Valve end switch (optional)		UI (0-5 V, Therm Dry)	IN-11 - 5 & 6	UI
Return Static Sensor	0 -5 VDC	UI (0-5 V, Therm Dry)	IN-10 - 3 & 4	AI
Open		UI (0-5 V, Therm Dry)	IN-9 - 1 & 2	DI
Supply Duct High Static*		BI (Dry contact)	IN-8 - 15 & 16	DI
Supply Fan Thermal Overload*		BI (Dry contact)	IN-7 - 13 & 14	DI
Water Flow Proving switch		BI (Dry contact)	IN-6 - 11 & 12	DI
Return Fan Thermal Overload (optional)*		BI (Dry contact)	IN-5 - 9 & 10	DI
Filter Input*		BI (Dry contact)	IN-4 - 7 & 8	DI
Return Plenum High Static*		BI (Dry contact)	IN-3 - 5 & 6	DI
Return Fan Status Switch*		BI (Dry contact)	IN-2 - 3 & 4	DI
Smoke Detector Input*		BI (Dry contact)	IN-1 - 1 & 2	DI
Outputs				
Open		BO (Dry contact)	BO-8 - 15 & 16	DO
Open		BO (Dry contact)	BO-7 - 13 & 14	DO
Open		BO (Dry contact)	BO-6 - 11 & 12	DO
Open		BO (Dry contact)	BO-5 - 9 & 10	DO
Return Fan Enable *		BO (Dry contact)	BO-4 - 7 & 8	DO
Damper Command start/stop*		BO (Dry contact)	BO-3 - 5 & 6	DO
Economizer Valve Command		BO (Dry contact)	BO-2 - 3 & 4	DO
Condenser water valve Command (start/stop)		BO (Dry contact)	BO-1 - 1 & 2	DO

**LEGEND**

- AI** — Analog Input
- AO** — Analog Output
- BI** — Digital Input
- BO** — Digital Output
- UI** — Universal Input

\* Inputs and outputs are optional. Sensors not provided. 50BV units do not contain a return fan; return fan control is available for return fan separate from 50BV unit.

† Read-only points. No effect on Sequence of Operation.

NOTE: Transformer's common terminals are tied together.

- Connect the analog output wiring to the screw terminals on the I/O Flex 6126 controller and to the controlled device (Fig. 23).

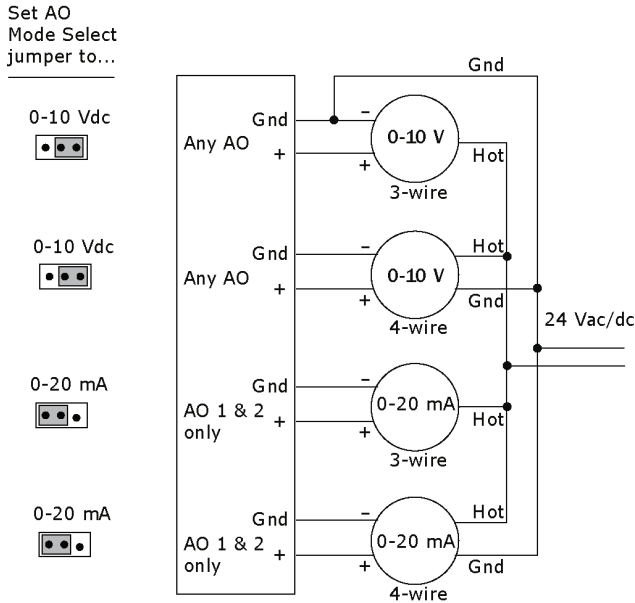

**Fig. 23 — Analog Output Diagram**

- Set the AO Mode Select jumper to the type of device the output is being wired to.
- Turn on the I/O Flex 6126 controller's power (Fig. 24).

### I/O Flex EX8160 Expander Module

**GENERAL DESCRIPTION** — The I/O Flex EX8160 expander expands the input/output capability of the I/O Flex 6126 controller. The I/O Flex 6126 controller supports one I/O Flex EX8160 expander.

The I/O Flex EX8160 expander is mounted onto the I/O Flex 6126 controller enclosure.

The expander may also be mounted separately within the mounting enclosure. Screw the I/O Flex EX8160 expander into an enclosed panel using the mounting holes provided on the cover plate. Be sure to leave about 2 inches (5 centimeters) on each side for wiring. Connect the I/O Flex EX8160 expander to the I/O Flex 6126 controller before applying power to either one. See Fig. 25.

#### Connecting I/O Flex EX8160 Expander and I/O Flex 6126 Controller

- Turn off the power to both the I/O Flex EX8160 expander and the I/O Flex 6126 controller.
- Wire the screw terminals connecting each devices' XNET Remote Expansion connector.
- Turn on the power to both the I/O Flex EX8160 expander and the I/O Flex 6126 controller.

**BACVIEW<sup>6</sup>** — The BACview<sup>6</sup> tool is a keypad/display unit that is required to connect to the I/O Flex 6126 controller to view or edit certain property values and the controller's real time clock.

Connect the BACview<sup>6</sup> tool to the I/O Flex 6126 controller's Rnet port. The I/O Flex 6126 controller can share the Rnet with RS sensors and a second I/O Flex 6126 controller, with no more than 6 devices total on the Rnet. Wire the devices in a daisy-chain or hybrid configuration.

The BACview<sup>6</sup> tool can be used with the I/O Flex 6126 controller with a 4-pin Rnet port. For instructions on using/programming the BACview<sup>6</sup> tool, refer to the BACview<sup>6</sup> programmer's guide.

### Water to Air Operation, VAV Units Only — 50BVJ,W

**GENERAL DESCRIPTION** — The factory-mounted I/O Flex 6126 controller and I/O Flex EX8160 expander are factory configured with the Water to Air application program and factory installed in the unit to be job site ready to run.

The unit will operate in a 100% stand-alone control mode or connect to a Building Automation System (BAS) using open protocols including BACnet (ARCNET and MS/TP), Modbus\* RTU, or LonWorks†. The controllers also support communications for BACview keypad/display panels.

#### KEY FEATURES AND BENEFITS

- Point count: 6 digital outputs, 12 universal inputs, and 6 analog outputs.
- Point count: 8 digital outputs, 8 digital inputs and 8 analog inputs
- Built-in protocol support: BACnet (ARCNET and MS/TP) and Modbus.
- Built-in local access support: BACview<sup>6</sup> keyboard/display.
- On-board lithium battery holds controller time clock settings
- Program archived in non-volatile memory allows unit to be ready after long periods of power outages.
- Parameter settings archived in nonvolatile memory allows unit configuration to be available after long periods of power outages.

#### CONTROL AND STATUS PARAMETERS AND ALARMS

##### Control

- BACview occupancy schedule
- System control: Schedule, Manual ON, BAS command or DI Enable
- Unit blower control
- Compressor 1 control
- Compressor 2 control
- Compressor 3 control
- Compressor 4 control
- Unit Enable manual control (optional)
- Humidity control (modulating hot gas re-heat optional)
- Condenser water valve control (flex required)
- Economizer control
- Damper control

##### Status

- Cooling control status
- Cooling demand percentage (0 to 100%)
- Discharge air temperature
- Return air temperature
- Leaving water temperature
- Entering water temperature
- Unit filter status (optional)
- Fan-Hours runtime counter (filter replacement indicator)
- Fan starts counter
- Compressor 1 starts counter
- Compressor 2 starts counter
- Compressor 3 starts counter
- Compressor 4 starts counter

\* Modbus is a registered trademark of Schneider Electric.

† LonWorks is a registered trademark of Echelon Corporation.

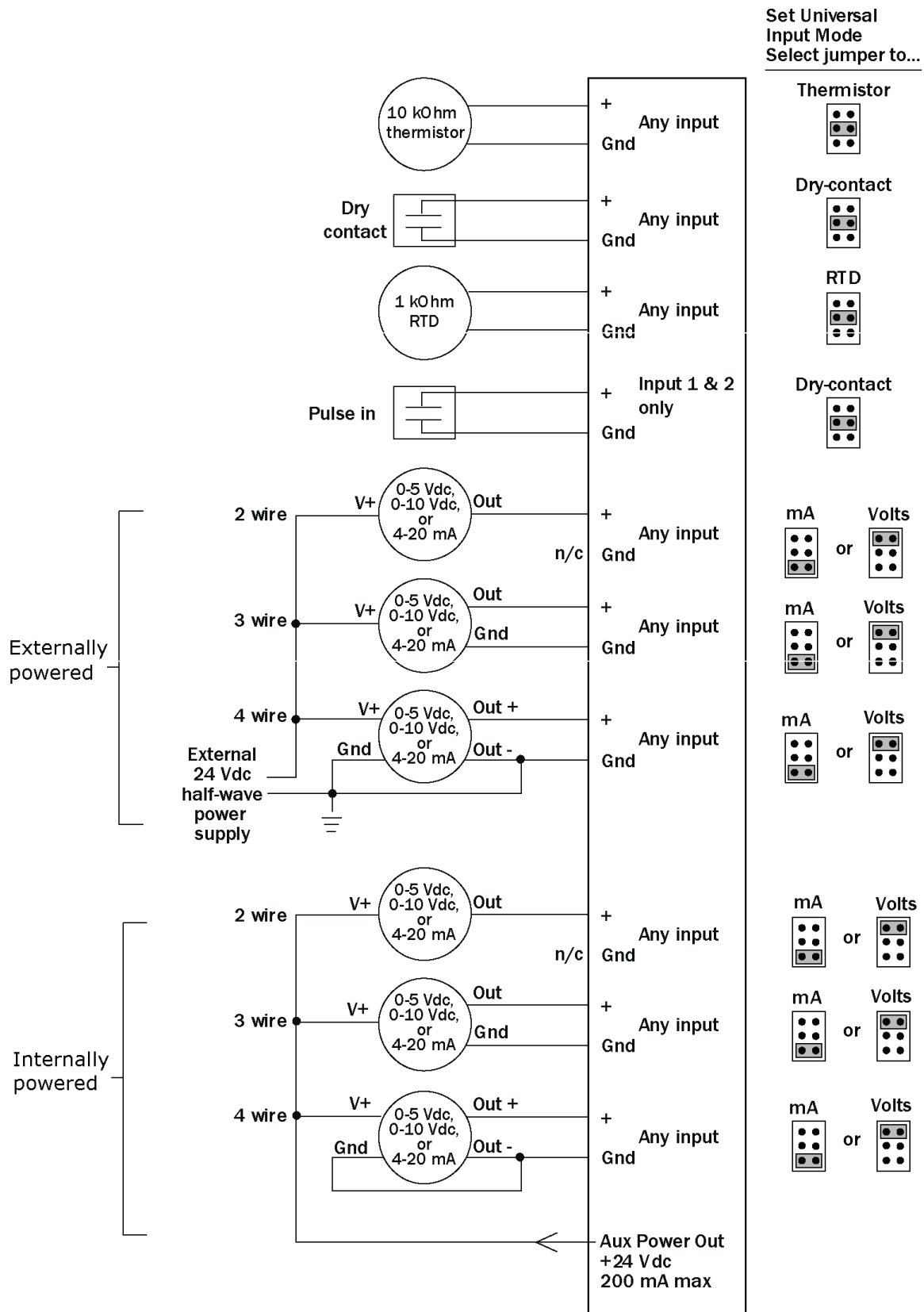
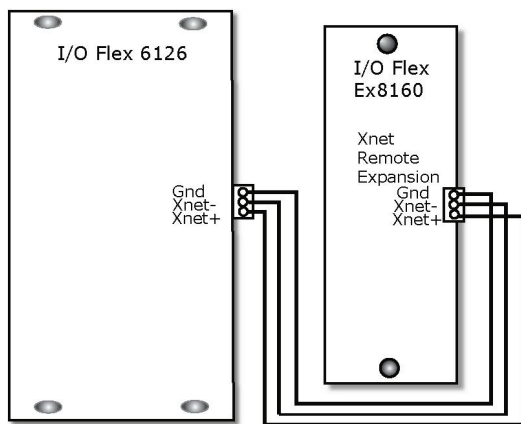

Fig. 24 — I/O Flex 6126 Controller Input Modes and Diagram



**Fig. 25 — Flex and Expansion XNET Connection**

### Alarms

- Leaving water temperature high/low trip
- Discharge air temperature high/low trip
- Entering water temperature high/low trip
- Sensor failure alarm
- Unit filter runtime trip (optional)
- Comp 1 runtime trip
- Comp 2 runtime trip
- Comp 3 runtime trip
- Comp 4 runtime trip
- Freeze stat sensor UPM alarm (optional)
- Low pressure sensor UPM alarm
- High pressure sensor UPM alarm
- Low pressure sensor UPM alarm
- High pressure sensor UPM alarm
- Condensate overflow UPM alarm
- High/low voltage UPM alarm

**Sequence of Operation, VAV Units Only — 50BVJ,W** — See the integration points list on page 65 for specific points and values.

**CONTROL SOURCE (RUN CONDITIONS)** — The unit may have external or internal control sources to initiate heating or cooling operation.

**EXTERNAL CONTROL SOURCE** — The unit may be controlled from the following external sources:

- Digital input
- BAS – Building Automation System
- Manual on

**DIGITAL INPUT** — Provides a method of running the unit by providing a contact closure (On/Off) to UI-12. Digital input provides a simple interface for enabling unit operation. Once enabled, the unit will run until the occupied set point has been satisfied.

**BAS** — Provides a network interface to the heat pump. The I/O Flex 6126 controller supports the following building automation protocols:

COMMUNICATION PROTOCOL	
BACnet	Building Automation and Control network
Modbus	Common open industrial protocol standard
LonWorks	LonWorks Automation and control network (Card required)

**MANUAL ON** — Places the unit in manual run mode; the unit will operate until the set point is satisfied.

**INTERNAL CONTROL SOURCE (KEYPAD)** — All controllers are provided with a battery backup real time clock. When configured for Keypad, the internal scheduler uses the local time and user schedule to initiate unit operation. Occupied Schedule: 56 F supply air set point (adjustable).

**Unit Mode** — The Unit Mode is used to configure the heat pump per its specific design configuration and application. A unit mode may be selected from the following:

- Cooling only
- Cooling only with hot gas re-heat

**COOLING ONLY** — The unit is configured for mechanical cooling.

**COOLING ONLY WITH HOT GAS RE-HEAT** — The unit is configured for cooling only with active humidity control. Please see Discharge Air Control with Modulating Re-Heat for additional details.

**Fan Modes** — The Fan mode option is used to select the type of fan hardware being used with the unit. Fan hardware is application specific and will determine the behavior for the specific application for which it is being applied.

The Fan option may be configured with one of the following options:

- Supply Air Fan (SAF) Start/Stop (also known as On/Off signaling)
- Variable Frequency Drive (or Variable Fan used in VAV applications)
- Return Fan interlock with Supply Fan (If SAF runs RAF runs)

**START/STOP FANS** — The fan enable signal is provided on BO-1 of the I/O Flex 6126 controller; operation is interlocked with cooling and re-heat operations. The return air fan can be enabled via the BACview tool, and it will be commanded 5 seconds after the supply fan has been engaged at all times.

The supply fan can also be set to stop if the return fan is in alarm via the BACview tool.

**VARIABLE FREQUENCY DRIVE (VFD) FAN** — The VFD uses an analog signal (0 to 10V) to control the speed of the blower. This signal is output from Analog Output 1 (AO-1) of the I/O Flex 6126 controller.

The supply and return air fan speeds are modulated by independent PID loops to maintain independent static pressure set points; the factory-provided duct static pressure sensor is required as input (connected to UI 11 for supply and IN-10 for return) on the I/O Flex 6126 controller and the I/O Flex EX8160 expander, for the VFD blower option. Units do not allow for mounting of the Return Fan VFD inside the equipment and require the VFD equipment to be mounted close to the unit. An inside wall in the mechanical room close to the unit is typically used for mounting an external VFD. See Table 28 for VFD factory default settings.

**SUPPLY AND RETURN FAN OPERATION** — When the unit control is set for occupied operation the fan will run continuously as the default behavior. If the return fan is enabled, it will follow the operation of the supply fan mode which may be modified to cycle only during mechanical operation. During unoccupied operation the fan will only cycle during a call to maintain a cooling set point.

**FAN OPERATION DURING DISCHARGE (SUPPLY AIR TEMPERATURE) AIR CONTROL (DAC)** — For DAC applications, the fan's speed is calculated as a demand percent calculated based on the PID static pressure sensor value and the static pressure set point.

If static pressure reset strategies are utilized the minimum fan speed recommended is 40% of nominal CFM. If the fan demand is less than 40% of nominal CFM (20% for the return fan) the PID loop will be disregarded and the fan will run at the minimum value.

Units configured for discharge air control will run only when the controller is in occupancy mode.

**VFD CONTROL** — The following applies for VFD Control:

- Variable frequency drive fan control requires a static pressure measurement. A duct static pressure sensor is factory supplied to be installed in the field.
- The static pressure sensor uses inches of water column as the unit of measure.
- The static pressure sensor is configured for UI-11 port of the I/O Flex 6126 controller for the supply duct and IN-10 for the return air duct.
- The static pressure set point is user configurable and is used by the static pressure PID control.
- The minimum VFD fan speed is user configurable and is set during the test and balance phase of the commissioning phase.
- A high static pressure alarm will be generated for a static pressure exceeding the maximum static pressure trip point for a minimum of 10 minutes.
- The static pressure sensor will be range-validated and a sensor failure alarm will be generated for a missing sensor.
- The VFD output may be switched to a constant value for a smoke event if enabled.

**FAN OPERATION DURING SMOKE EVENT** — The speed of the fan during a smoke event is user configurable for VFD enabled units (defaults to 100%).

**FAN HISTORY STATISTICS** — The controller will collect fan history statistics and sum the total number of fan start events that occurred in the preceding 1-hour period. The fan history may be reset by the user. Fan history reset may be performed locally at the unit with a BACview terminal.

**Digital Inputs for Monitoring** — The controller software may be configured to provide digital inputs for monitoring unit faults and alarms. The equipment integrator must configure the input for the appropriate installed option and desired

function. The functional options may be configured via a local terminal or building automation system.

**FILTER STATUS (DFS)** — The I/O Flex 6126 controller has the option of providing a filter alarm for indicating that the filter needs servicing. The filter-status service option may be implemented with hardware or with fan run time. The filter switch hardware is connected directly to IN-4 on the I/O Flex EX8160 expander with a contact closure indicating a service event.

The following applies to the filter status:

- The filter status (replacement) may be configured for accumulated running time.
- The total fan run time prior to filter service is user configurable, factory default 2000 hrs.
- The filter timer may be reset upon the filter being serviced.

**WATER DIFFERENTIAL PRESSURE SWITCH (DPS)** — The differential pressure switch is applied to a unit for which the flow of water through the heat exchange must be confirmed prior to the unit operating. The differential pressure switch hardware is connected directly to IN-6.

In addition, the following applies to the DPS option:

- An alarm notification is set if the DPS is asserted True (no flow condition).
- A DPS alarm will terminate compressor operation.
- Three DPS events will hard lockout the unit.
- The DPS hard lockout condition which will keep the unit off can be cleared by a reset via the BACview tool.
- A sum of all DPS events will be logged for a 1-hour period.

**SMOKE DETECTOR STATUS (SDS)** — The unit may be set up to receive a smoke event via a contact closure. The smoke detector input is available for field wiring on IN-1 of the I/O Flex EX8160 expander.

The response to a smoke event must be determined by safety regulations and jurisdiction of the local governing body. The smoke detector response must be enabled and set up upon system start-up. The default behavior for a smoke event will terminate the operation of the unit (fan and compressor).

The unit may be configured for operation during a smoke event for specific safety applications. Variable Frequency Drive configured units can be configured for a specific fan speed during a smoke event.

A smoke detector contact closure on IN-1 will produce a Smoke Alert.

**COMPRESSOR STATUS** — The unit is equipped with compressor status current transducers and Input Expansion Modules (IEM) and will verify that the compressor stages are running by monitoring the status of the current switches. If the compressor fails (no current flow) an individual alarm per compressor stage will occur.

The controller will identify the compressor operating in the following three modes:

- Auto (no alarm)
- Hand mode
- Failed

**Cooling Operation** — The controller will maintain the supply air temperature and set point by staging the compressor(s). To prevent short-cycling, there is a 10-minute delay between compressor stages. Additionally, there will be a 3-minute delay (adjustable) to prove water flow prior to Compressor 1 operation when the unit is first powered on. The compressor will run subject to internal safeties and controls provided by the UPM board.

**Table 28 — VFD Factory Default Settings**

ABB 550 DRIVE FACTORY CONFIGURATION VFD 1			
GROUP NUMBER	PARAMETER NUMBER	DESCRIPTION	VALUE
99	9902	Application Macro	HVAC Default
	9904	Motor control Mode	Scalar
	9905	Motor Nominal Voltage	
	9906	Motor Nominal Current	
	9907	Motor Nominal Frequency	
	9908	Motor Nominal Speed	
	9909	Motor Nominal Power	
10	1001	EXT1 Commands	DI1 - Start/Stop
	1002	EXT2 Commands	N/A
	1003	Direction	Forward
11	1103	REF1 Select	AI-1
	1104	REF1 Minimum	0Hz at 60Hz/ 0Hz at 50Hz
	1105	REF 1 Maximum	60 Hz at 60Hz / 50 Hz at 50Hz
12	1201	Constant Speed Select	NOT SEL
	1202	Constant Speed Value (Field Programmable)	6Hz - Motor Nominal Frequency
13	1301	Minimum AI-1	0%
	1302	Maximum AI-1	100%
	1303	Filter AI-1	1 Sec
	1304	Minimum AI-2	0%
	1305	Maximum AI-2	100%
	1306	Filter AI-2	1 Sec
14	1401	Relay Output 1	Ready
	1402	Relay Output 2	Run
	1403	Relay Output 3	Fault (Inverted)
15	1507	AO2 Content	AI-1 (Used to control VFD2 Refer-
	1508	AO2 Content Min	0%
	1509	AO2 Content Max	100%
	1510	Minimum AO2	0.0mA
	1511	Maximum AO2	20.0mA
	1512	Filter AO2	1 Sec
16	1601	Run Enable	DI-1
	1608	Start Enable 1	DI-4
	1609	Start Enable 2	N/A
20	2002	Minimum Fan Speed	0
	2003	Maximum Current	30% higher that Motor (s) FLA
	2007	Minimum Frequency	0Hz
	2008	Maximum Frequency	60Hz / 50Hz (Per motor frequency rat-
21	2101	Start Function	Fly Start
	2102	Stop Function	Coast
22	2202	Accelerate Time	30 Seconds
	2203	Decelerate Time	30 Seconds
26	2605	Volt/ Freq Ratio	Square
	2606	Switching Frequency	4Khz
	2607	Switching Frequency Control	ON

\*Refer to Motor name plate.

**Table 28 — VFD Factory Default Settings (cont)**

ABB 550 DRIVE FACTORY CONFIGURATION VFD 1			
GROUP NUMBER	PARAMETER NUMBER	DESCRIPTION	VALUE
30	3006	Motor Thermal Time	1050s
	3007	Motor Load Curve	100%
	3008	Zero Speed Load	70%
	3009	Break Point Frequency	35Hz
	3010	Stall Function	NOT SEL
	3011	Stall Frequency	20 Hz
	3012	Stall Time	20 Sec
	3017	Earth Fault	Enabled
31	3101	Number of Retries	5
	3102	Trial Time	30Sec
	3103	Delay Time	6 Sec
	3104	AR Overcurrent	Enabled
	3105	AR Overvoltage	Enabled
	3106	AR Undervoltage	Enabled
	3107	AR AI<Minimum	Disabled
	3108	AR External Fault	(0) Disabled
34	3401	Signal Parameter 1	Output Freq
	3402	Signal 1 Minimum	0
	3403	Signal 1 Maximum	60 / 50 (Maximum motor operating Hertz)
	3404	Output 1 DPS Form	0
	3405	Output 1 DSP Unit	% SP
	3406	Output 1 Minimum	0
	3407	Output 1 Maximum	100
	3408	Signal Parameter 2	Current (Motor Current Measured by the Drive)
	3409	Signal 2 Minimum	0
	3410	Signal 2 Maximum	FLA + 15% A
	3411	Output 2 DPS Form	0
	3412	Output DSP Unit	A (2)
	3413	Output 2 Minimum	0
	3414	Output 2 Maximum	FLA + 15% A
	3415	Signal Parameter 3	AI-1
	3416	Signal 3 Minimum	0
	3417	Signal 3 Maximum	10
	3418	Output 3 DPS Form	0
	3419	Output DSP Unit	V (2)
	3420	Output 3 Minimum	0
3421	Output 3 Maximum	10	
40	4001	Gain	2.5
	4002	Integration Time	3Sec
	4005	Error Value Inver	NO
	4006	Units	%
	4007	Display Format	x.xxx
	4010	Setpoint Select	Internal
	4012	Setpoint Minimum	0V
	4013	Setpoint Maximum	10V
4027	PID1 Parameter Set	SET1	



**Table 28 — VFD Factory Default Settings (cont)**

DRIVE FACTORY CONFIGURATION VFD 2			
GROUP NUMBER	PARAMETER NUMBER	DESCRIPTION	VALUE
99	9902	Application Macro	HVAC Default
	9904	Motor control Mode	Scalar
	9905	Motor Nominal Voltage	*
	9906	Motor Nominal Current	*
	9907	Motor Nominal Frequency	*
	9908	Motor Nominal Speed	*
	9909	Motor Nominal Power	*
10	1001	EXT1 Commands	DI1 - Start/Stop
	1002	EXT2 Commands	N/A
	1003	Direction	Forward
11	1103	REF1 Select	AI-1
	1104	REF1 Minimum	0Hz at 60Hz/ 0Hz at 50Hz
	1105	REF 1 Maximum	60 Hz at 60Hz / 50 Hz at 50Hz
12	1201	Constant Speed Select	NOT SEL
	1202	Constant Speed Value (Field Programmable)	6Hz - Motor Nominal Frequency
13	1301	Minimum AI-1	0%
	1302	Maximum AI-1	100%
	1303	Filter AI-1	1 Sec
	1304	Minimum AI-2	0%
	1305	Maximum AI-2	100%
	1306	Filter AI-2	1 Sec
14	1401	Relay Output 1	Ready
	1402	Relay Output 2	Run
	1403	Relay Output 3	Fault (Inverted)
15	1507	AO2 Content	AI-1
	1508	AO2 Content Min	0%
	1509	AO2 Content Max	100%
	1510	Minimum AO2	0.0mA
	1511	Maximum AO2	20.0mA
	1512	Filter AO2	1 Sec
16	1601	Run Enable	DI-1
	1608	Start Enable 1	DI-4
	1609	Start Enable 2	N/A
20	2002	Minimum Fan Speed	0
	2003	Maximum Current	30% higher that Motor (s) FLA
	2007	Minimum Frequency	0Hz
	2008	Maximum Frequency	60Hz / 50Hz (Per motor frequency rating)
21	2101	Start Function	Fly Start
	2102	Stop Function	Coast
22	2202	Accelerate Time	30 Seconds
	2203	Decelerate Time	30 Seconds
26	2605	Volt/ Freq Ratio	Square
	2606	Switching Frequency	4Khz
	2607	Switching Frequency Control	ON

\*Refer to Motor name plate.

**Table 28 — VFD Factory Default Settings (cont)**

DRIVE FACTORY CONFIGURATION VFD 2			
GROUP NUMBER	PARAMETER NUMBER	DESCRIPTION	VALUE
30	3006	Motor Thermal Time	1050s
	3007	Motor Load Curve	100%
	3008	Zero Speed Load	70%
	3009	Break Point Frequency	35Hz
	3010	Stall Function	NOT SEL
	3011	Stall Frequency	20 Hz
	3012	Stall Time	20 Sec
	3017	Earth Fault	Enaled
31	3101	Number of Retries	5
	3102	Trial Time	30Sec
	3103	Delay Time	6 Sec
	3104	AR Overcurrent	Enabled
	3105	AR Overvoltage	Enabled
	3106	AR Under voltage	Enabled
	3107	AR AI<Minimum	Disabled
	3108	AR External Fault	(0) Disabled
34	3401	Signal Parameter 1	Output Freq
	3402	Signal 1 Minimum	0
	3403	Signal 1 Maximum	60 / 50 (Maximum motor operating Hertz)
	3404	Output 1 DPS Form	0
	3405	Output 1 DSP Unit	% SP
	3406	Output 1 Minimum	0
	3407	Output 1 Maximum	100
	3408	Signal Parameter 2	Current (Motor Current Measured by the Drive)
	3409	Signal 2 Minimum	0
	3410	Signal 2 Maximum	FLA + 15% A
	3411	Output 2 DPS Form	0
	3412	Output DSP Unit	A (2)
	3413	Output 2 Minimum	0
	3414	Output 2 Maximum	FLA + 15% A
	3415	Signal Parameter 3	AI-1
	3416	Signal 3 Minimum	0
	3417	Signal 3 Maximum	20mA
	3418	Output 3 DPS Form	0
	3419	Output DSP Unit	mA(2)
	3420	Output 3 Minimum	0
	3421	Output 3 Maximum	20
40	4001	Gain	2.5
	4002	Integration Time	3Sec
	4005	Error Value Inver	NO
	4006	Units	%
	4007	Display Format	x.xxx
	4010	Setpoint Select	Internal
	4012	Setpoint Minimum	0V
	4013	Setpoint Maximum	10V
	4027	PID1 Parameter Set	SET1

\*Refer to Motor name plate.

For discharge air control applications the minimum on-times and off-times in Table 29 are applicable:

**Table 29 — Discharge Air Control**

COMPR 1		COMPR 2		COMPR 3		COMPR 4	
Min ON	Min OFF	Min ON	Min OFF	Min ON	Min OFF	Min ON	Min OFF
10	5	10	5	10	5	7	5

If for any reason the compressor alarms reset, the unit compressors will start within 10 seconds of each other.

COOLING — Cooling will be enabled whenever:

- Unit is in occupied mode
- The fan output is on
- The loop valve is open

COOLING MODE — When commanded into cooling mode, the unit will energize the condenser water valve and wait for its valve end switch to be made prior to energizing the compressors.

Once the valve has been proved open the unit will command the compressor to stage according to the cooling percentage required. This value is provided via a reverse acting PID loop which compares the supply air temperature (SAT) value and the SAT cooling set point (AV:66).

The unit monitors return air temperature to assure air entering the unit is greater than 60 F (adjustable) prior to running in the cooling with modulating hot gas reheat, when the controller is set to operate with multiple reset points. If the controller is set to operate with single return temperature reset the factory default value will be the free cooling value 50 F (adjustable).

If at any time the cooling set point is greater than the return air temperature (RAT) the unit will enter into economizer assist mode.

Compressors will be staged as follows:

Compressor 1 will run:

When the fan is running

AND the condenser valve is proved.

AND the cooling demand is greater than 25%

Compressor 2 will run:

When compressor one has run for 10 minutes

AND the cooling demand is greater than 50%

Compressor 3 will run:

When compressor two has run for 10 minutes

AND the cooling demand is greater than 75%

Compressor 4 will run:

When compressor 2 has run for 10 minutes

AND the cooling demand is greater than 90%

When the unit runs in cooling mode the hot gas re-heat valve will be enabled and modulated to maintain supply air temperature set point, factory default is 55 F (AV:93, adjustable)  $\pm$  4° F.

DISCHARGE AIR CONTROL WITH MODULATING RE-HEAT — When in cooling mode, if the unit is equipped with modulating hot gas re-heat, the hot gas re-heat will be enabled and modulated to maintain supply air temperature set point, factory default is 55 F (adjustable)  $\pm$  4° F.

The cooling stages can be reset based on a single point or multiple return air temperature (RAT) values as follows:

Single:

Free Cooling 50 F < RAT

Mechanical Cooling RAT > 50 F (enabled)

Multiple:

Free Cooling 50 F < RAT < 59° F

Mechanical Cooling (Comp 1) 60 F < RAT < 69 F (adj.)

Mechanical Cooling (Comp 2) 70 F < RAT < 77 F (adj.)

Mechanical Cooling (Comp 3) 78 F < RAT < 83 F (adj.)

Mechanical Cooling (Comp 4) RAT > 83 F (adj.)

All values have a hysteresis of 2.0° F.

If discharge air set point reset is required, when the value of the discharge air set point is greater than the value of the return air reset for a particular compressor, the return limit will have to be adjusted via the BACnet tool to compensate for the demand changes and release. The particular compressor stage or the unit must be set to a single reset point and the discharge set point reset can be adjusted as needed.

Any of the following alarms will immediately shut down all compressor stages. Refer to the sensor section or the integration points list for default values:

- Leaving water high
- Leaving water low
- Entering later low
- Fan alarms
- Low static pressure
- Water differential pressure switch (DPS)
- Smoke

DISCHARGE AIR TEMPERATURE (DAT) SENSOR — The DAT sensor is shipped loose in the electrical controls box compartment and is to be field installed in the supply duct work and terminated on UI-6 of the I/O Flex 6126 controller.

The sensor should be installed where the air flow pattern is laminar to avoid temperature stratification. If supplemental heating is to be installed then the DAT sensor should be mounted downstream of the discharge side of the heating coil.

HIGH DISCHARGE AIR TEMPERATURE CONDITION (COOLING) — DAT measurements are tested for a high limit trip above 70 F. An alarm is asserted for high discharge air temperature under the following conditions:

- DAT is above the high limit for 5 minutes
- Fan operation asserted
- Cooling mode
- Valid DAT sensor measurement

HIGH STATIC LOCK — The controller will monitor the static pressure high limit switch (if installed) and will increment a counter every time the static pressure switch trips. A High Static Alarm will be generated, and will reset automatically. Upon receiving the alarm 3 times, the unit will lock out to protect the ductwork and prevent cycling of major unit components.

If the lock state is reached in addition to the high static alarm, code 100 will be set and broadcast over the BACnet network via the Systems Status point (AV: 16).

Since the controller interprets this as an issue that needs technical assistance, the unit can only be reset from its HMI BACview tool.

**WATERSIDE ECONOMIZER MODE** — If the entering water temperature is less than the set point 55 F (adjustable) the unit will transition to economizer mode:

- Disable mechanical cooling stage 1 operation for minimum of 12 minutes.
- Enable economizer valve.
- Waterside economizer will operate until the entering water temperature reset value is reached; default is 58 F (adjustable).

When in economizer mode, if the entering water temperature reaches the reset value in less than 5 minutes, the first stage of mechanical cooling operation will be disabled for at least 5 minutes.

In economizer operation, if the unit requires additional stages of mechanical cooling, the controller will command them according to the unit demand percentage calculated by the Cooling PID. If additional stages of cooling were running those will be maintained.

The fan will continue to modulate to meet the static pressure set point, the economizer valve will be commanded to open, and the economizer will be treated as the first stage of cooling.

**LEAVING WATER TEMPERATURE (LWT)** — The controller will monitor the leaving water temperature. Alarms will be provided as follows:

- High Leaving Water Temp: If compressor(s) is running and the leaving water temperature is greater than 135 F (adjustable).
- Low Leaving Water Temp: If compressor(s) is running and the leaving water temperature is less than 33 F (adjustable).
- Leaving Water Sensor Failure: If leaving water sensor outside of normal operating limits. Should a High or

Low Leaving Water Temperature Alarm occur, the call for cooling will be removed.

**UPM Fault Monitor** — The controller will monitor both Unit Protection Modules (UPM1 and UPM2) fault inputs.

Upon hard lockout alarm, compressors are disabled by the UPM board.

Alarms will be provided through BACnet point current alarm (AV:17) as follows:

- HP1: High Pressure Alarm (circuit 1)
- HP2: High Pressure Alarm (circuit 2)
- LP1: Low Pressure Alarm (circuit 1)
- LP2: Low Pressure Alarm (circuit 2)
- HP3: High Pressure Alarm (circuit 3)
- HP4: High Pressure Alarm (circuit 4)
- LP3: Low Pressure Alarm (circuit 3)
- LP4: Low Pressure Alarm (circuit 4)
- FRE: Freeze Alarm
- FRE2: Freeze Alarm
- CON: Condensate Alarm B
- RN: Brownout Alarm

**Troubleshooting**

**COMMUNICATION LEDS** — The LEDs indicate if the controller is speaking to the devices on the network. The LEDs should reflect communication traffic based on the baud rate set. The higher the baud rate the more solid the LEDs become.

The Run and Error LEDs indicate controller and network status. See Table 30 for Communication LEDs and Table 31 for Run and Error LEDs.

**Table 30 — Communication LEDs**

LEDS	STATUS
POWER	Lights when power is being supplied to the controller.
RX	Lights when the controller receives data from the network segment; there is an Rx LED for Ports 1 and 2.
TX	Lights when the controller transmits data from the network segment; there is an Tx LED for Ports 1 and 2.
RUN	Lights based on controller health.
ERROR	Lights based on controller health.

NOTE: The I/O Flex 6126 controller is protected by internal solid-state polyswitches on the incoming power and network connections. These polyswitches are not replaceable, but they will reset themselves if the condition that caused the fault returns to normal.

**Table 31 — Run and Error LEDs**

IF RUN LED SHOWS...	AND ERROR LED SHOWS...	STATUS IS...
	Off	Normal
2 flashes per second	2 flashes, alternating with Run LED	Five minute auto-restart delay after system error
	3 flashes, then off	The controller has just been formatted
	4 flashes, then pause	Two or more devices on this network have the same ARC156 network address
	1 flash per second	The controller is alone on the network
	On	Exec halted after frequent system errors or control programs halted
	5 flashes per second	On
Off		Firmware transfer in progress, boot is running
7 flashes per second	7 flashes per second, alternating with Run LED	Ten-second recovery period after burnout
14 flashes per second	14 flashes per second, alternating with Run LED	Burnout
Alternating flashes with Error LED	Alternating flashes with the Run LED	The controller files have been archived
On	On	Failure. Try the following solutions: <ul style="list-style-type: none"> <li>• Turn the I/O Flex 6126 controller off, then on.</li> <li>• Format the I/O Flex 6126 controller.</li> <li>• Download memory to the I/O Flex 6126 controller.</li> <li>• Replace the I/O Flex 6126 controller.</li> </ul>

**COMPLIANCE**

**⚠ CAUTION**

This unit uses a microprocessor control system. Do not short or jumper between terminations on circuit boards or modules; control or board failure may result.

Be aware of electrostatic discharge (static electricity) when handling or making contact with circuit boards or module connections. Always touch a chassis (grounded) part to dissipate body electrostatic charge before working inside control center.

Use extreme care when handling tools near boards and when connecting or disconnecting terminal plugs. Circuit boards can easily be damaged. Always hold boards by the edges and avoid touching components and connections.

This equipment uses, and can radiate, radio frequency energy. If not installed and used in accordance with the instruction manual, it may cause interference to radio communications. It has been tested and found to comply with the limits for a Class A computing device pursuant to International Standard in North America EN61000-2/3 which are designed to provide reasonable protection against such interference when operated in a commercial environment. Operation of this equipment in a residential area is likely to cause interference, in which case the user, at his own expense, will be required to take whatever measures may be required to correct the interference.

Always store and transport replacement or defective boards in an anti-static shipping bag.

**SERVICE**

**⚠ CAUTION**

**Improper phase sequence will cause scroll compressor failure due to reverse rotation.**

**Compressor Rotation** — To determine whether or not the compressor is rotating in the proper direction:

1. Connect service gages to suction and discharge pressure fittings.
2. Energize the compressor.
3. Turn off power to the unit and tag disconnect.
4. Reverse any 2 of the unit power leads.

The suction pressure should drop and the discharge pressure should rise, as is normal on any start-up. If the suction pressure does not drop and the discharge pressure does not rise to normal levels:

Reapply power to the unit. The suction and discharge pressure levels should now move to their normal start-up levels.

Also, check that the fan is rotating in the proper direction. Incorrect wiring can lead to improper phase sequence resulting in scroll compressor failure due to reverse rotation. Signs of reverse rotation include:

- Excessive noise
- Reverse rotation of 3 phase indoor fan
- Rapid temperature rise on suction tube
- No pressure differential
- No cooling

Correct immediately. Shut off power at disconnect and switch any 2 power leads at unit terminal block or pigtails.

**Fan Motor Replacement** — If required, replace the fan motor with an equal or better type and efficiency motor with equal horsepower. The motor must be rated for a VFD or inverter application. Do not change the horsepower unless there is a system design requirement change and VFD size analysis.

**CHECK/CHANGE VFD OUTPUT CURRENT LIMIT** — The VFD provides additional fan motor protection by limiting the output current to a programmed value. This value has been factory set according to the factory-installed motor and VFD sizing options.

If the VFD and/or motor is replaced, the VFD setup mode parameter "tHr1" should be reprogrammed to the following calculated values for optimum motor protection and operating range:

For VFD size about equal to motor:

$$tHr1 = 100 * \text{motor nameplate Amps} / \text{VFD rated output Amps}$$

## MAINTENANCE

**Cleaning Unit Exterior** — Unit exterior panels should be wiped down using a damp soft cloth or sponge with a mixture of warm water and a mild detergent.

**Coil Cleaning** — Hot water, steam, and direct expansion coils must be cleaned at least once a year to maintain peak performance. Dirty coils can contribute to decreased heating or cooling capacity and efficiency, increased operating costs, and compressor problems on direct expansion systems. Dirt, grease, and other oils can also reduce the wettability of the coil surfaces, which can result in moisture blow-off from cooling coils and resulting water leakage problems. If the grime on the surface of the coils becomes wet, which commonly occurs with cooling coils, microbial growth (mold) can result, causing foul odors and health-related indoor air quality problems.

Coils can become dirty over a period of time, especially if air filter maintenance is neglected. Coils should be inspected regularly and cleaned when necessary. Clean coils with a vacuum cleaner, fresh water, compressed air, or a bristle brush (not wire). Do **not** use high-pressure water or air—damage to fins may result. Backflush coil to remove debris. Commercial coil cleaners may also be used to help remove grease and dirt. Steam cleaning is **NOT** recommended. After cleaning, use a fin comb of the correct fin spacing when straightening mashed or bent coil fins.

Units installed in corrosive environments should be cleaned as part of a planned maintenance schedule. In this type of application, all accumulations of dirt should be cleaned off the coil.

**Inspection** — Check coil baffles for tight fit to prevent air from bypassing the coil. Check panels for air leakage, particularly those sealing the fan and coil compartments. Check for loose electrical connections, compressor oil levels, proper refrigerant charge, and refrigerant piping leaks. Before start-up, be sure all optional service valves are open.

**Air Filters** — The 50BV single-piece units come with 1-in. filters. The standard 1-in. filters provide lower pressure drop and longer filter service intervals. The 50BV modular units come with 4-in. filters.

Inspect air filters every 30 days and replace filters as necessary.

Replacement filters should have a minimum efficiency rating of MERV 6 per ASHRAE rating procedures and be rated for up to 625 fpm velocity. Job requirements or local codes may specify higher minimum ratings.

**Condensate Drains** — Clean the drain line and unit drain pan at the start of each cooling season. Check flow by pouring water into the drain.

**Water-Cooled Condensers** — Water-cooled condensers may require cleaning of scale (water deposits) due to improperly maintained closed-loop water systems. Sludge build-

up may need to be cleaned in an open tower system due to inducted contaminants.

Local water conditions may cause excessive fouling or pitting of tubes. Condenser tubes should be cleaned at least once a year, or more often if the water is contaminated.

Proper water treatment can minimize tube fouling and pitting. If such conditions are anticipated, water treatment analysis is recommended. Refer to the System Design Manual, Part 5, for general water conditioning information.

### CAUTION

Follow all safety codes. Wear safety glasses and rubber gloves when using inhibited hydrochloric acid solution. Observe and follow acid manufacturer's instructions.

Isolate the supply and return water connections when removing piping to the condenser.

Clean condensers with an inhibited hydrochloric acid solution. The acid can stain hands and clothing and attack concrete, and, without inhibitor, can attack steel. Cover surroundings to guard against splashing. Vapors from vent pipe are not harmful, but take care to prevent liquid from being carried over by gases.

Warm solution acts faster, but cold solution is just as effective if applied for a longer period.

**GRAVITY FLOW METHOD (FIG. 26)** — Do not add solution faster than the vent can exhaust the generated gases.

When condenser is full, allow the solution to remain overnight; then drain the condenser and flush with clean water. Follow acid manufacturer's instructions.

**FORCED CIRCULATION METHOD (FIG. 27)** — Fully open the vent pipe when filling the condenser. The vent may be closed when the condenser is full and the pump is operating.

Regulate the flow to the condenser with a supply line valve. If the pump is the non-overloading type, the valve may be fully closed while the pump is running.

For average scale deposit, allow the solution to remain in the condenser overnight. For heavy scale deposit, allow a full 24 hours. Drain the condenser and flush with clean water. Follow acid manufacturer's instructions.

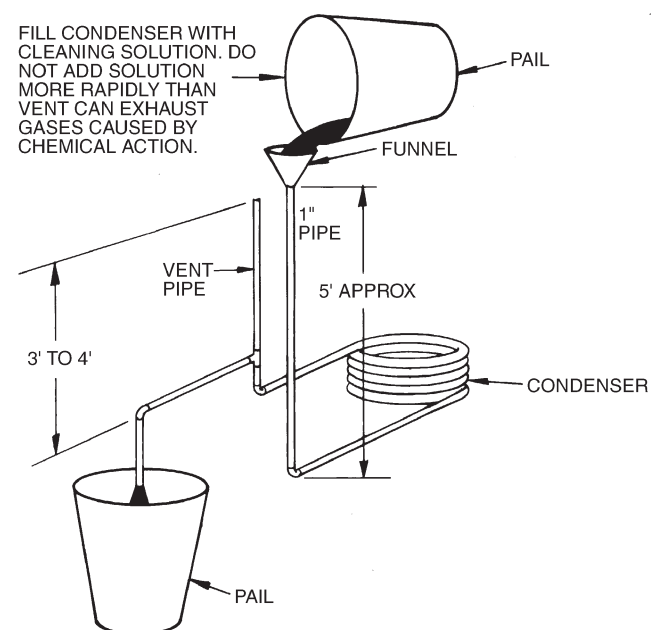
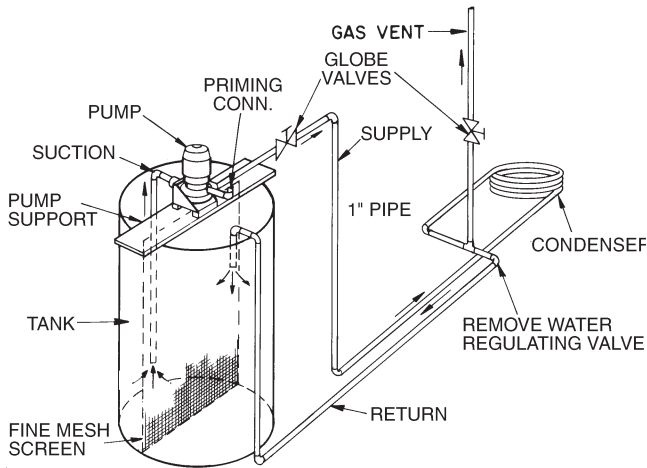

Fig. 26 — Gravity Flow Method



**Fig. 27 — Forced Circulation Method**

**Fan Motor Lubrication** — The fan motor was properly lubricated at the time of manufacture. Lubricate the fan motor(s) with SAE-20 (Society of Automotive Engineers) non-detergent electric oil.

**IMPORTANT: PILLOW BLOCK STYLE FAN BEARINGS:** Bearings have been prelubricated with high quality grease. Bearings must be relubricated once every 6 months or every 2500 hours of operation, whichever comes first.

**Fan Bearing Lubrication** — Inspect the fan bearings for proper lubrication every 6 month or 2500 hours of operation, whichever comes first. Standard units have grease fittings on the fan shaft bearings, located on each side of the blower wheel. Lubricate bearings with a lithium-based grease (NLGI Grade 2).

**Fan Sheaves** — Factory-supplied drives are pre-aligned and tensioned; however, it is recommended that the belt tension and alignment be checked before starting the unit. Always check the drive alignment after adjusting belt tension.

To install sheaves on the fan or motor shaft:

1. Isolate power to the unit.
2. Remove side unit access panel(s).
3. Remove any rust-preventive coating on the fan shaft.
4. Make sure the shaft is clean and free of burrs. Add grease or lubricant to bore of sheave before installing.
5. Mount sheave on the shaft; to prevent bearing damage, do not use excessive force.

Each factory-assembled fan, shaft, and drive sheave assembly is precision aligned and balanced. If excessive unit vibration occurs after field replacement of sheaves, the unit should be rebalanced. To change the drive ratio, follow the steps in the Evaporator Fan Performance Adjustment section (page 55).

After 1 to 3 minutes of operation, check the belt tension. Also check tension frequently during the first 24 hours of operation and adjust if necessary. Periodically check belt tension throughout the run-in period, which is normally the initial 72 hours of operation.

**ALIGNMENT** — Make sure that fan shafts and motor shafts are parallel and level. The most common causes of misalignment are nonparallel shafts and improperly located sheaves. Where shafts are not parallel, belts on one side are drawn tighter and pull more than their share of the load. As a result, these belts wear out faster, requiring the entire set to be replaced before it has given maximum service. If misalignment is in the

sheave, belts enter and leave the grooves at an angle, causing excessive belt and sheave wear.

**Shaft Alignment** — Check shaft alignment by measuring the distance between the shafts at 3 or more locations. If the distances are equal, then the shafts are parallel.

**Sheave Alignment**

1. To check the location of the fixed sheaves on the shafts, use a straightedge or a piece of string. If the sheaves are properly aligned, the string will touch them at the points indicated by the arrows in Fig. 28. Rotate each sheave a half revolution to determine whether the sheave is wobbly or the drive shaft is bent. Correct any misalignment.
2. With sheaves aligned, tighten cap screws evenly and progressively.

NOTE: There should be a 1/8-in. to 1/4-in. gap between the mating part hub and the bushing flange. If the gap is closed, the bushing is probably the wrong size.

3. With taper-lock bushed hubs, be sure the bushing bolts are tightened evenly to prevent side-to-side pulley wobble. Check by rotating sheaves and rechecking sheave alignment. When substituting field-supplied sheaves for factory-supplied sheaves, only the motor sheave should be changed.

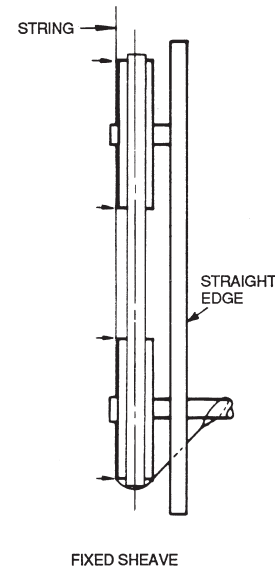

**Fig. 28 — Sheave Alignment**

**Evaporator Fan Performance Adjustment** —

To change fan speeds from factory settings:

1. Shut off unit power supply.
2. Loosen nuts on the 4 carriage bolts in the mounting base. Using adjusting bolts and plate, slide the motor and remove the belt.
3. Loosen movable-pulley flange setscrew.
4. Screw the movable flange toward the fixed flange to increase speed, and away from the fixed flange to decrease speed. Increasing the fan speed increases the load on the motor. Do not exceed the maximum speed specified in Tables 2 and 3.
5. Set the movable flange at nearest keyway of the pulley hub and tighten the setscrew. (See Tables 2 and 3 for speed change for each full turn of pulley flange.)
6. Replace and tighten the belts (see Belt Tension Adjustment section).
7. Restore power to the unit.

To align fan and motor pulleys:

1. Loosen fan pulley setscrews.

2. Slide fan pulley along fan shaft.
3. Make angular alignment by loosening motor from mounting plate.
4. Restore power to unit.

**BELT TENSION ADJUSTMENT** — Using a gage, apply 4 lb of force to the center of the belt and adjust the tension until a deflection of  $1/64$ -in. is achieved for every inch of shaft center distance. See Fig. 29.

Ideal belt tension is the lowest value under which belt slip will not occur at peak load conditions.

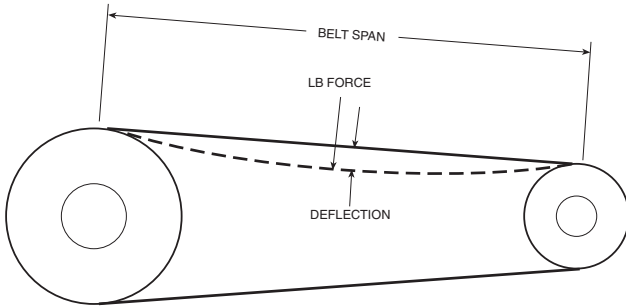

**Fig. 29 — Fan Belt Tension**

**Compressor Oil** — All units are factory charged with oil. It is not necessary to add oil unless compressor(s) is removed from the unit. If necessary, oil can be removed/charged via Schrader fitting. Operate the system at high evaporator temperature prior to oil recharge to assist oil return to the compressor(s) from other system components. If necessary, recharge the system as shown in Table 32.

**Table 32 — Oil Recharge**

50BV UNIT	SIZE	COMPRESSOR	OIL CHARGE (OZ)	OIL TYPE
C, Q, J	020	ZP94KCE	81	3MA-POE
	024	ZP103KCE	106	
	028	ZP137KCE	106	
	034	ZP182KCE	106	
T, V, W	034	ZP182KCE	106	
	044	ZP120KCE	106	
	054	ZP137KCE	106	
	064	ZP182KCE	106	

### TROUBLESHOOTING

Refer to Tables 33 and 34 to determine the possible cause of the problem and the associated procedure necessary to correct it.



**Table 33 — Unit Troubleshooting**

<b>PROBLEM</b>	<b>POSSIBLE CAUSE</b>	<b>CORRECTION PROCEDURE</b>
Unit Will Not Start.	Loss of unit power	Check power source. Check fuses, circuit breakers, disconnect switch. Check electrical contacts.
	Unit voltage not correct	Check and correct.
	Open fuse	Check for short circuit in unit.
	Open protection device	Check relays (phase monitor option), contacts, pressure switches.
	Unit or motor contactor out of order	Test and replace if necessary.
Fan Does Not Operate.	Contactors or relay overload or out of order	Test and replace if necessary.
	VFD not running	Confirm VFD parameters set.
	Motor defective	Test and replace if necessary.
	Broken belt	Replace belt.
	Loose electrical contact	Tighten contact.
Compressor is Noisy, But Will Not Start.	Under voltage	Check and correct.
	Defect in compressor motor	Replace compressor.
	Missing phase	Check and correct.
	Compressor seized	Check and replace if necessary.
Compressor Starts, But Does Not Continue to Run.	Compressor or contact defect	Test and replace if necessary.
	Unit is under charged	Check and correct any leaks. Add refrigerant.
	Unit is too big	Check load calculation.
	Compressor is overloaded	Check protection device and replace. Check for missing phase. Check TXV. Check temperature in suction discharge line.
Unit is Noisy.	Compressor noise	Check TXV and replace if necessary. Compressor rotation incorrect; check and correct. Check internal noise.
	Tube vibration or condenser water problem	Check and correct.
	Unit panel or part vibrating	Check and tighten appropriate part.
Unit Runs Continuously, But Has Low Capacity.	Unit is too small	Check load calculation.
	Low refrigerant or noncondensing gas present	Check for leaks and add refrigerant or gas as necessary.
	Compressor defect	Check pressure and amps. Replace if necessary.
	Insufficient flow of refrigerant in evaporator	Check filter drier and replace if necessary. Check TXV and adjust or replace if necessary. Check position of TXV bulb and equalizer.
	Oil in evaporator	Drain evaporator.
	Low airflow	Check filters, and clean or replace as necessary. Check coils, and clean as necessary. Check for restrictions in ductwork. Check fan rotation and adjust. Check fan motor. Check belts for wear.
High Discharge Pressure.	Low waterflow in condenser	Purge air.
	Dirty condenser tubes.	Clean condenser.
	High temperature in condenser water	Check water tower fans and pumps.
	Overcharged	Check and reclaim excess charge. Adjust subcooling.
	Noncondensing gas present	Verify and correct.

**LEGEND**

- TXV** — Thermostatic Expansion Valve
- VFD** — Variable Frequency Drive

**Table 34 — CV Units LED Diagnostic Codes**

<b>NO. OF BLINKS</b>	<b>DESCRIPTION</b>
1	1st Stage High-Pressure Lockout
2	1st Stage Low-Pressure Lockout
3	2nd Stage High-Pressure Lockout
4	2nd Stage Low-Pressure Lockout
5	Freeze Protection Lockout*
6	Condensate Overflow Lockout*

\*Freeze protection and condensate overflow lockout require optional sensors.

NOTE: The main control board has a red LED (light-emitting diode) for fault indication and will blink a code as described above. Count the number of blinks to determine the lockout condition.

### **SCHEMATICS**

Refer to Fig. 30-34 for voltage and wiring schematics.

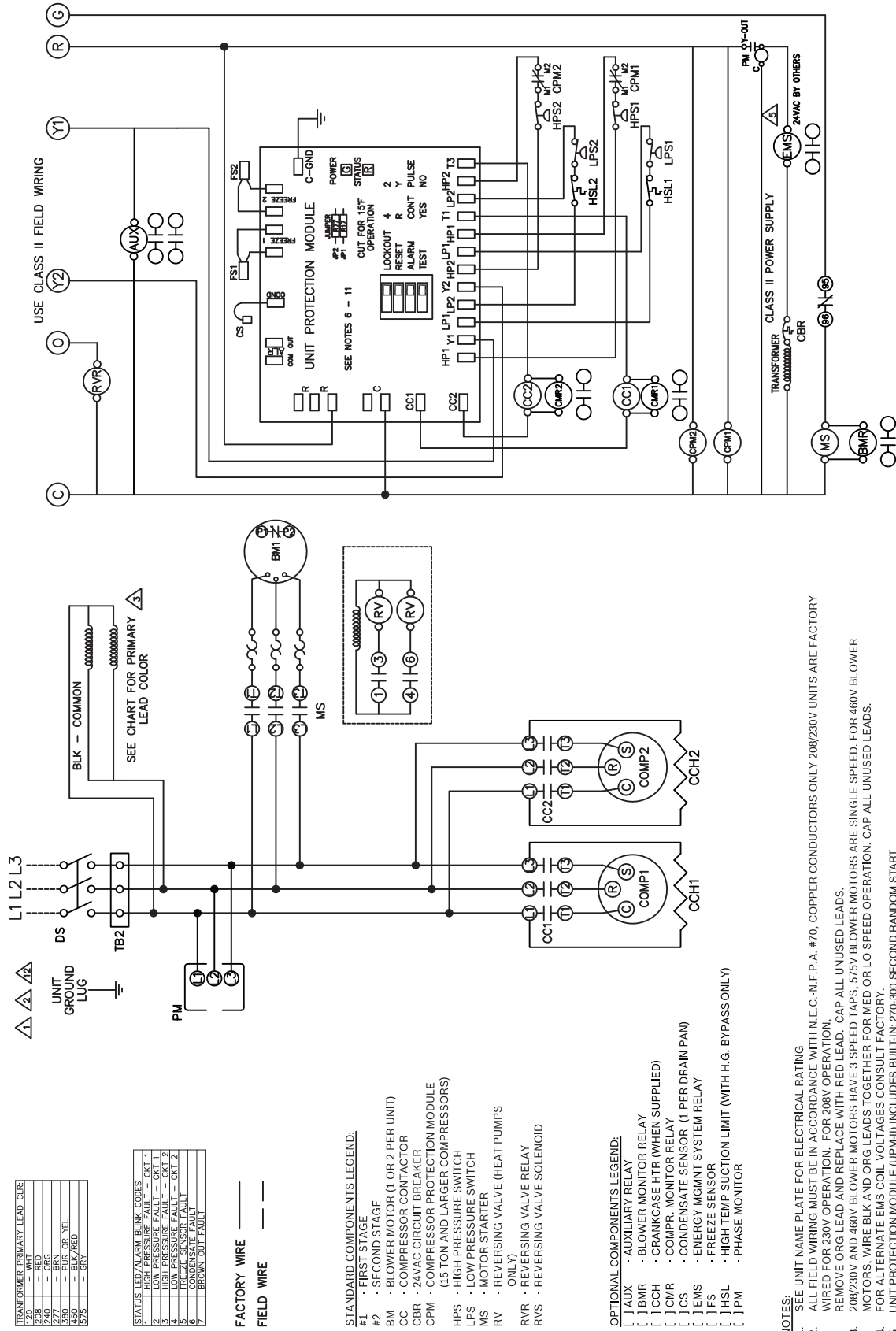

TRANSFORMER PRIMARY LEAD COLOR	
120	- WHI
208	- RED
240	- BRN
277	- BRN
347	- PUR OR YEL
380	- BLK/RED
460	- BLK/RED
575	- GRN

STATUS LED/ALARM BLINK CODES	
1	HIGH PRESSURE FAULT - OKT 1
2	LOW PRESSURE FAULT - OKT 1
3	HIGH PRESSURE FAULT - OKT 2
4	LOW PRESSURE FAULT - OKT 2
5	REVERSING VALVE FAULT
6	CONDENSATE FAULT
7	BROWN OUT FAULT

FACTORY WIRE ———  
FIELD WIRE - - - - -

**STANDARD COMPONENTS LEGEND:**

- #1 - FIRST STAGE
- #2 - SECOND STAGE
- BM - BLOWER MOTOR (1 OR 2 PER UNIT)
- CC - COMPRESSOR CONTACTOR
- CBR - 24VAC CIRCUIT BREAKER
- CPM - COMPRESSOR PROTECTION MODULE (15 TON AND LARGER COMPRESSORS)
- HPS - HIGH PRESSURE SWITCH
- LPS - LOW PRESSURE SWITCH
- MS - MOTOR STARTER
- RV - REVERSING VALVE (HEAT PUMPS ONLY)
- RVR - REVERSING VALVE RELAY
- RVS - REVERSING VALVE SOLENOID

**OPTIONAL COMPONENTS LEGEND:**

- [ ] AUX - AUXILIARY RELAY
- [ ] BMR - BLOWER MONITOR RELAY
- [ ] CCH - CRANKCASE HTR (WHEN SUPPLIED)
- [ ] CMR - COMP. MONITOR RELAY
- [ ] CS - CONDENSATE SENSOR (1 PER DRAIN PAN)
- [ ] EMS - ENERGY MGMT SYSTEM RELAY
- [ ] FS - FREEZE SENSOR
- [ ] HSL - HIGH TEMP SUCTION LIMIT (WITH H.G. BYPASS ONLY)
- [ ] PM - PHASE MONITOR

**NOTES:**

1. SEE UNIT NAME PLATE FOR ELECTRICAL RATING. ALL FIELD WIRING MUST BE IN ACCORDANCE WITH N.E.C.-N.F.P.A. #70. COPPER CONDUCTORS ONLY. 208/230V UNITS ARE FACTORY WIRED FOR 230V OPERATION. FOR 208V OPERATION, REMOVE ORG LEAD AND REPLACE WITH RED LEAD. CAP ALL UNUSED LEADS.
2. 208/230V AND 460V BLOWER MOTORS HAVE 3 SPEED TAPS. S75V BLOWER MOTORS ARE SINGLE SPEED. FOR 460V BLOWER MOTORS, WIRE BLK AND ORG LEADS TOGETHER FOR MED OR LO SPEED OPERATION. CAP ALL UNUSED LEADS.
3. UNIT PROTECTION MODULE (UPM-H) INCLUDES BUILT-IN: 270-300 SECOND RANDOM START  
300 SECOND DELAY ON BREAK  
120 SECOND LOW PRESSURE BYPASS
4. "TEST" DIP SWITCH REDUCES DELAYS TO 10 SEC WHEN SET TO YES. MUST BE SET TO "NO" FOR NORMAL OPERATION. "FREEZE SENSOR" WILL OPERATE AT 30°F BY DEFAULT. IF 15°F OPERATION IS REQUIRED, JUMPERS R77 & R17 MUST BE CUT IF "FREEZE SENSOR IS NOT INSTALLED. A JUMPER SHALL BE INSTALLED BETWEEN THE FREEZE SENSOR TERMINALS.
5. "ALARM OUTPUT" DIP SWITCH MUST BE SET TO "PULSE" IF BLINKING T-STAT SERVICE LIGHT IS DESIRED.
6. DEFAULT SETTINGS FOR UPM BOARD FROM FACTORY SHOWN. ALSO SEE INSTALLATION MANUAL.
7. ALARM OUTPUT IS NORMALLY OPEN (NO) DRY CONTACT. IF 24 VAC IS NEEDED, CONNECT R TO ALR-COM TERMINAL. 24VAC WILL BE SENSED ON THE ALR-OUT WHEN THE UNIT IS IN ALARM CONDITION. OUTPUT WILL BE PULSED IF PULSE IS SELECTED.
8. CHECK FOR PROPER PHASE ROTATION ON UNITS WITH SCROLL COMPRESSORS. REVERSE ROTATION WILL DAMAGE THE COMPRESSOR AND VOID UNIT WARRANTY.

**Fig. 30 — 50BVC,Q,T,V020-034 Constant Volume Wiring Schematic**

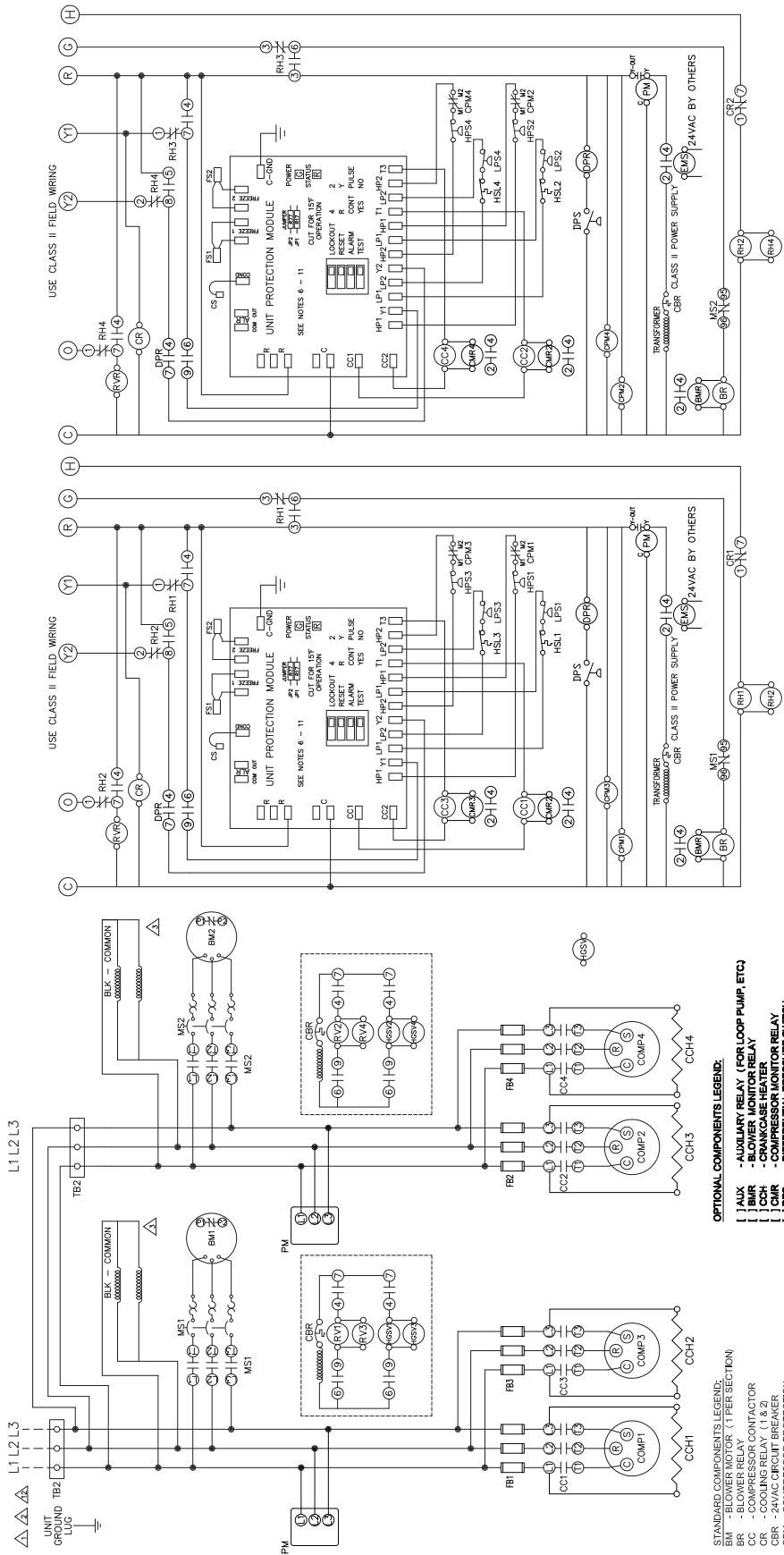

TRANSFORMER PRIMARY LEAD, CLR.
120 - WHT
208 - RED
240 - ORG
360 - BLK
480 - BLK/RED
575 - GRY

STATUS LED/ALARM BLINK CODES
1 HIGH PRESSURE FAULT - CKT 1
2 LOW PRESSURE FAULT - CKT 1
3 HIGH PRESSURE FAULT - CKT 2
4 LOW PRESSURE FAULT - CKT 2
5 FREEZE SENSOR FAULT
6 CONDENSATE FAULT
7 BROWN OUT FAULT

FACTORY WIRE \_\_\_\_\_  
FIELD WIRE \_\_\_\_\_

- OPTIONAL COMPONENTS LEGEND:**
- [ ] AUXILIARY RELAY (FOR LOOP PUMP, ETC)
  - [ ] BLOWER MONITOR RELAY
  - [ ] CRANKCASE HEATER
  - [ ] COMPRESSOR MONITOR RELAY
  - [ ] DIFFERENTIAL PRESSURE SWITCH
  - [ ] DIFFERENTIAL PRESSURE SWITCH RELAY
  - [ ] DRY CONTACT RELAY (ENABLES CCI, CC2)
  - [ ] ENERGY MGMT SYSTEM RELAY (WITH H.C. BYPASS ONLY)
  - [ ] HPS (USED WITH DDC CONTROLLER ONLY)
  - [ ] HGVIS
  - [ ] PM

- STANDARD COMPONENTS LEGEND:**
- BM - BLOWER MOTOR (1 PER SECTION)
  - CC - COMPRESSOR CONTACTOR
  - CC - COOLING RELAY (1 & 2)
  - CR - 24VAC CIRCUIT BREAKER
  - CPI - COMPRESSOR PROTECTION (COMPRESSORS)
  - CS - CONDENSATE SENSOR (1 PER DRAIN PAN)
  - FS - FREEZE SENSOR
  - HPS - HIGH PRESSURE SWITCH
  - MS - MOTOR STARTER
  - RVS - REVERSING VALVE RELAY (HEAT PUMPS ONLY)
  - RVS - REVERSING VALVE SOLENOID (HEAT PUMPS ONLY)

- NOTES:**
1. UNIT NAME PLATE FOR ELECTRICAL RATING.
  2. ALL FIELD WIRING MUST BE IN ACCORDANCE WITH N.E.C.-N.F.P.A. #70. COPPER CONDUCTORS ONLY.
  3. 208/230V UNITS ARE FACTORY WIRED FOR 230V OPERATION. FOR 208V OPERATION, REMOVE ORG LEAD AND REPLACE WITH RED LEAD. CAP ALL UNUSED LEADS.
  4. 08/230V AND 08V BLOWER MOTORS HAVE 3 SPEED TAPS. 575V BLOWER MOTORS ARE SINGLE SPEED. FOR 480V BLOWER MOTOR, REMOVE 24VAC CIRCUIT BREAKER FOR LEAD OR LO SPEED OPERATION. CAP ALL UNUSED LEADS.
  5. UNIT PROTECTION MODULE (UPM-H) INCLUDES BUILT-IN 270-300 SECOND RANDOM START 300 SECOND DELAY ON BREAK RESTART PASS.
  7. "TEST" DIP SWITCH REDUCES DELAYS TO 10 SEC WHEN SET TO YES. MUST BE SET TO "NO" FOR NORMAL OPERATION.
  8. "FREEZE SENSOR" WILL OPERATE AT 30°F BY DEFAULT. IF 15°F OPERATION IS REQUIRED, JUMPER R42 MUST BE CUT.
  9. "IF FREEZE SENSOR IS NOT INSTALLED A JUMPER SHALL BE INSTALLED BETWEEN THE FREEZE SENSOR TERMINALS."
  10. DEFAULT SETTINGS FOR UPM BOARD FROM FACTORY SHOW ALSO SEE INSTALLATION MANUAL.
  11. ALARM OUTPUT IS NORMALLY OPEN (NO) DRY CONTACT. IF 24 VAC IS NEEDED, CONNECT R TO ALR-COM TERMINAL. 24VAC WILL BE SENSED ON THE ALR-OUT WHEN THE UNIT IS IN ALARM CONDITION. OUTPUT WILL BE PULSED IF PULSE IS SELECTED.
  12. COMPRESSOR AND 100 UNIT WARRANTY.

Fig. 31 — 50BVT, V044-064 Constant Volume Wiring Schematic



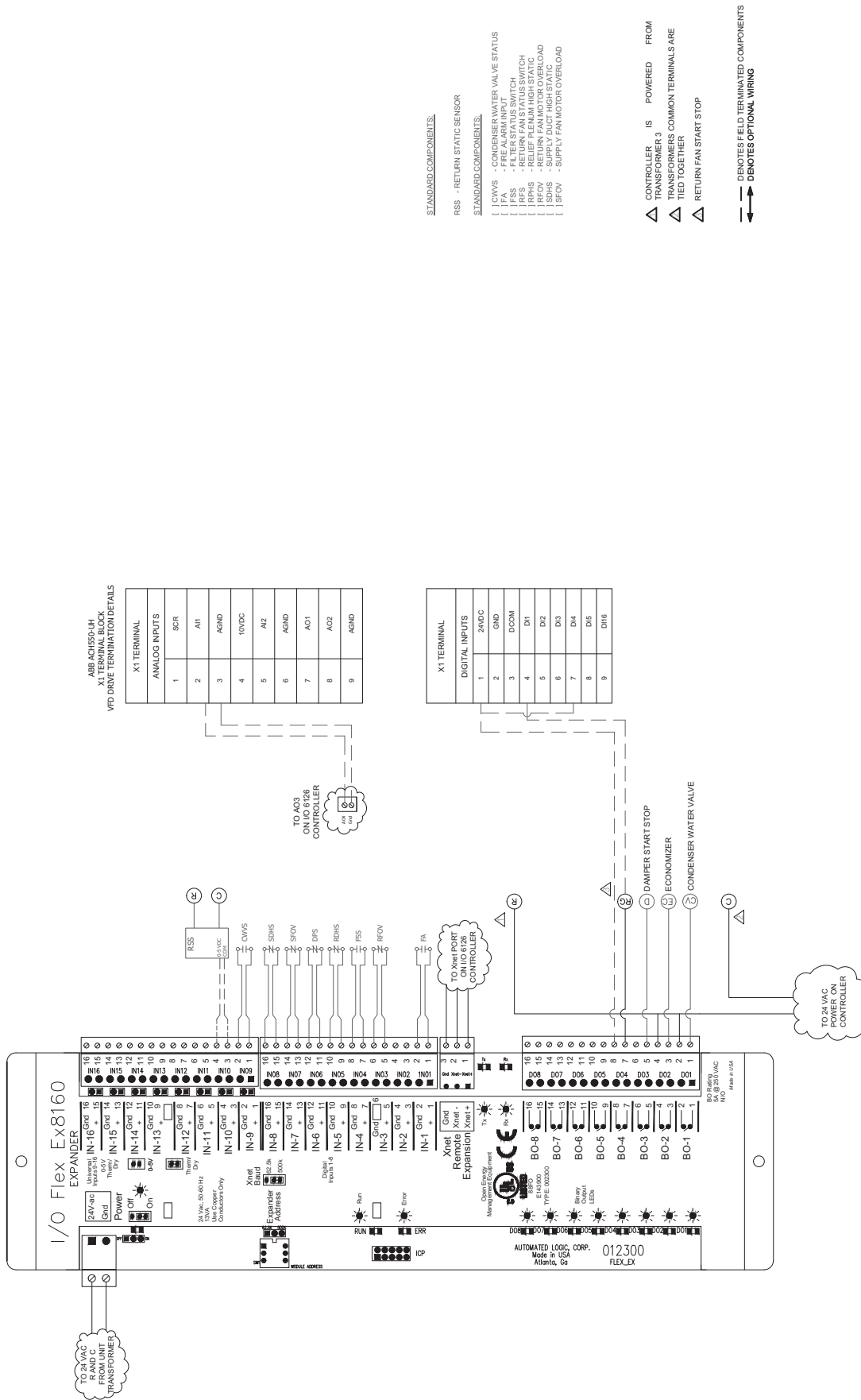

Fig. 33 — 50BVJ,W Variable Air Volume Control Expander Module Wiring Diagram

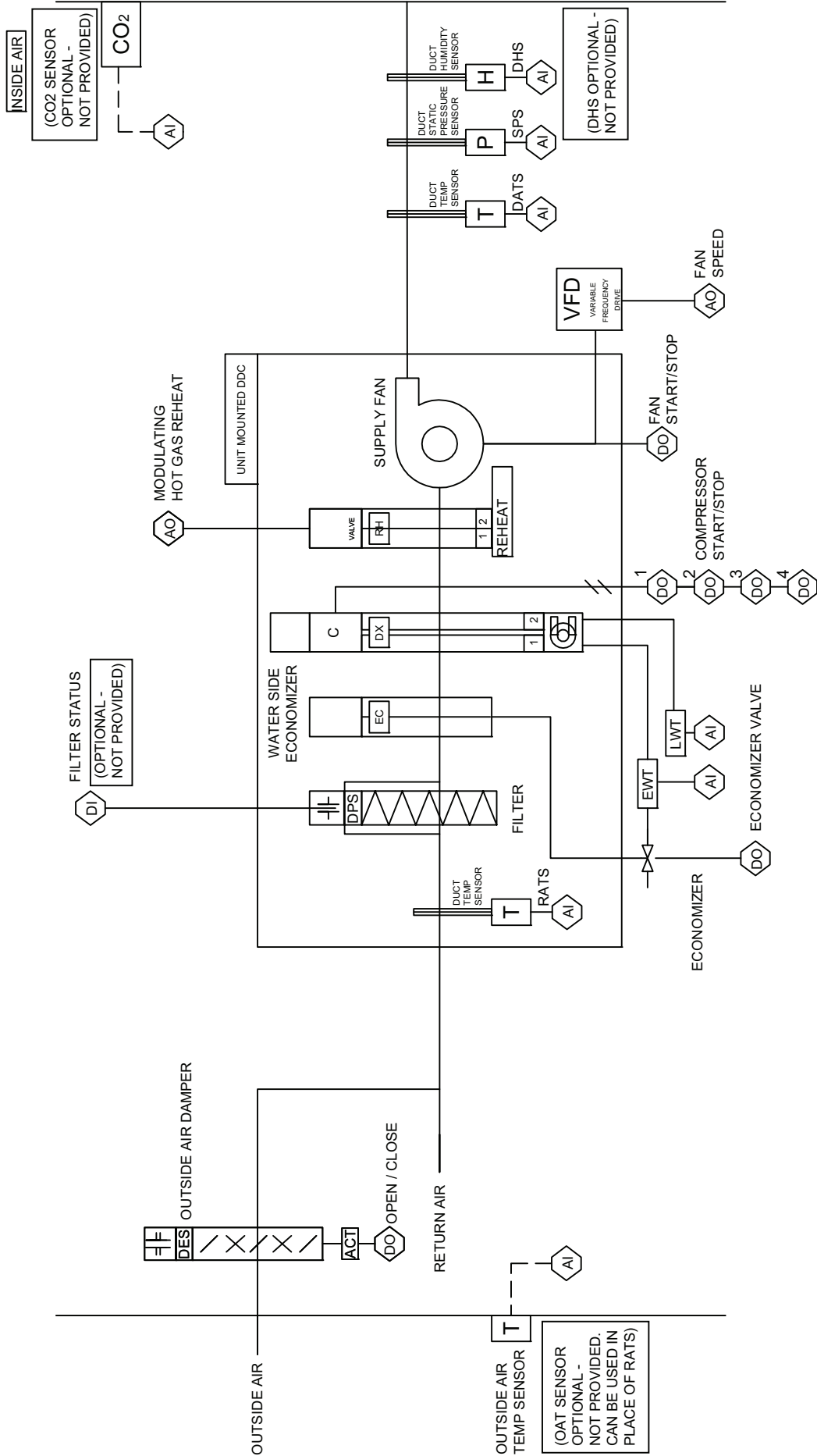

Fig. 34 — 50BVJ, W Sensor Schematic

## SENSORS AND INTEGRATION POINTS

Refer to Table 35 for factory-provided sensors and Table 36 for a detailed integration points list.

**Table 35 — Factory-Provided Sensors for VAV Units 50BVJ,W**

UNIT	DESCRIPTION	QTY	SHIPPING LOCATION	INSTALLATION LOCATION
50BVJ 020-034	Supply Air Temperature sensor	1	loose for field installation	Supply air stream
	Return Air Temperature Sensor	1	loose for field installation	Return air stream
	Entering Water Temperature	1	Installed	Condenser entering water
	Leaving Water Temperature	1	Installed	Condenser leaving water
	Duct Static Pressure Sensor	1	loose for field installation	Supply air stream
	Compressor Current Transducer	*	Installed	Unit electrical box
50BVW 034-064	Supply Air Temperature Sensor	1	loose for field installation	Supply air stream
	Return Air Temperature Sensor	4	loose for field installation	Return air stream
	Entering Water Temperature	1	Installed	Condenser entering water
	Leaving Water Temperature	1	Installed	Condenser leaving water
	Duct Static Pressure Sensor	1	loose for field installation	Supply air stream
	Compressor Current Transducer	*	Installed	Unit electrical box

\*1 per compressor.



**Table 36 — Integration Points List**

PROTOCOL MAP		MODBUS		BACNET			LONWORKS		OPERATION
DISPLAY NAME	READ/WRITE	REGISTER TYPE	REGISTER NUMBER	REFERENCE NAME	OBJECT TYPE	OBJECT ID	NV NAME	SNVT	DESCRIPTION
Alarm Status	R	Discrete Input	5	alm_status	BV	24	nvoAlm-Status	SNVT_switch(95)	Alarm Status of Unit (see "Current Alarm" for more information)
Allow CWV Alarm	R/W	Coil	1	allow_cwv_alarm	BV	106		Select	Enable Condensate Water Valve Alarm Pass Through 0 = Off 1 = Enable CWV Alarm
BAS CO2 Sensor Value	R/W	Holding Register (Float)	1	bas_co2_val	AV	49		Select	CO2 Sensor Value provided by BAS in PPM
BAS DAT Sensor	R/W	Holding Register (Float)	3	bas_dat_val	AV	90		Select	Discharge Air Temperature (DAT) provided by BAS in °F
BAS Return Air Temp	R/W	Holding Register (Float)	5	bas_rat	AV	29		Select	Return Air Temperature Value provided by the BAS
BAS RH Sensor Value	R/W	Holding Register (Float)	7	bas_rh_sensor_val	AV	56		Select	Relative Humidity (RH) provided by BAS in %
BAS SD Input	R/W	Coil	2	bas_sd_in	BV	91		Select	Network Parameter to set the BAS Smoke Detector Alarm
Boilerless-Economizer Status	R	Input Register (Float)	1	econ_boiler_mode_stat	AV	34		Select	Economizer Option Status 0 = Disabled 1 = Water Side Economizer
BRN	R	Discrete Input	6	brn_2st	BV	10		Select	Network Alarm indicating Brownout sense on UPM1
BRN	R	Discrete Input	7	brn_4st	BV	58		Select	Network Alarm indicating Brownout sense on UPM2
BV Occupancy Command (BAS)	R/W	Coil	3	occupancy_cmd	BV	1	nviOccBASCcmd	SNVT_switch(95)	Network Parameter to set the Occupancy Command 0 = Unoccupied (Default) 1 = Occupied
C1_FAIL	R	Discrete Input	8	comp1_fail	BV	150		Select	Network Alarm indicating compressor commanded to run but no current feedback is sensed
C1_HAND	R	Discrete Input	9	comp1_hand	BV	151		Select	Network Alarm indicating compressor is running but the controller is not issuing an automatic command.
C2_FAIL	R	Discrete Input	10	comp2_fail	BV	154		Select	Network Alarm indicating compressor commanded to run but no current feedback is sensed
C2_HAND	R	Discrete Input	11	comp2_hand	BV	155		Select	Network Alarm indicating compressor is running but the controller is not issuing an automatic command.
C3_FAIL	R	Discrete Input	12	comp3_fail	BV	157		Select	Network Alarm indicating compressor commanded to run but no current feedback is sensed
C3_HAND	R	Discrete Input	13	comp3_hand	BV	158		Select	Network Alarm indicating compressor is running but the controller is not issuing an automatic command.
C4_FAIL	R	Discrete Input	14	comp4_fail	BV	160		Select	Network Alarm indicating compressor commanded to run but no current feedback is sensed
C4_HAND	R	Discrete Input	15	comp4_hand	BV	161		Select	Network Alarm indicating compressor is running but the controller is not issuing an automatic command.

See legend on page 73.

**Table 36 — Integration Points List (cont)**

PROTOCOL MAP		MODBUS		BACNET			LONWORKS		OPERATION
DISPLAY NAME	READ/ WRITE	REGISTER TYPE	REGISTER NUMBER	REFERENCE NAME	OBJECT TYPE	OBJECT ID	NV NAME	SNVT	DESCRIPTION
CMP1_RNTM	R	Discrete Input	16	comp1_rntm	BV	35		Select	Compressor 1 Runtime Alarm Status, (8760 Hours) 0 = Off 1 = Timer Has Expired
CMP2_RNTM	R	Discrete Input	17	comp2_rntm	BV	36		Select	Compressor 2 Runtime Alarm Status, (Hours) 0 = Off 1 = Timer Has Expired
CMP3_RNTM	R	Discrete Input	18	comp3_rntm	BV	69		Select	Compressor 3 Runtime Alarm Status (Hours) 0 = Off 1 = Timer Has Expired
CMP4_RNTM	R	Discrete Input	19	comp4_rntm	BV	71		Select	Compressor 4 Runtime Alarm Status (Hours) 0 = Off 1 = Timer Has Expired
Co2 Sensor Ena	R/W	Holding Register (Float)	9	co2_sensor_ena	AV	26		Select	Zone CO2 Sensor Enable Setup 0 = No CO2 (Default) 1 = CO2 Monitoring 2 = CO2 + Damper 3 = CO2 BAS Monitoring 4 = CO2 BAS + Damper 5 = Open Damper as Fan runs
Coil Configuration Status	R	Input Register (Float)	3	coil_cfg_status	AV	150		Select	Network Status of Coil Configuration 0 = Parallel 1 = Series
Comp Stage1 Output Cmd	R	Discrete Input	20	cmp_stg1_cmd	BV	11	nvoC-mp1Cmd	SNVT_switch(95)	Compressor Stage 1 Output Status 0 = Compressor Stage 1 Off 1 = Compressor 1 On
Comp Stage2 Output Cmd	R	Discrete Input	21	cmp_stg2_cmd	BV	12	nvoC-mp2Cmd	SNVT_switch(95)	Compressor Stage 2 Output Status 0 = Compressor 2 Off 1 = Compressor 2 On
Comp Stage3 Output Cmd	R	Discrete Input	22	cmp_stg3_cmd	BV	66	nvoC-mp3Cmd	SNVT_switch(95)	Compressor Stage 3 Output Status 0 = Compressor 3 Off 1 = Compressor 3 On
Comp Stage4 Output Cmd	R	Discrete Input	23	cmp_stg4_cmd	BV	67	nvoC-mp4Cmd	SNVT_switch(95)	Compressor Stage 2 Output Status 0 = Compressor 4 Off 1 = Compressor 4 On
Comp1 Runtime Rst	R/W	Coil	4	cmp1_rntm_rst	BV	13	nviC-mp1RntRst	SNVT_switch(95)	Compressor 1 Runtime Reset. Momentary On/Off required.
Comp2 Runtime Rst	R/W	Coil	5	cmp2_rntm_rst	BV	14	nviC-mp2RntRst	SNVT_switch(95)	Compressor 2 Runtime Reset. Momentary On/Off required.
Comp3 Runtime Rst	R/W	Coil	6	cmp3_rntm_rst	BV	68	nviC-mp3RntRst	SNVT_switch(95)	Compressor 3 Runtime Reset. Momentary On/Off required.
Comp4 Runtime Rst	R/W	Coil	7	cmp4_rntm_rst	BV	70	nviC-mp4RntRst	SNVT_switch(95)	Compressor 4 Runtime Reset. Momentary On/Off required.
Compressor 1 Status	R	Discrete Input	3	comp1_status	BV	152		Select	Network Parameter indicating the status of Compressor 1
Compressor 2 Status	R	Discrete Input	2	comp2_status	BV	153		Select	Network Parameter indicating the status of Compressor 2
Compressor 3 Status	R	Discrete Input	1	comp3_status	BV	156		Select	Network Parameter indicating the status of Compressor 3
Compressor 4 Status	R	Discrete Input	4	comp4_status	BV	159		Select	Network Parameter indicating the status of Compressor 4
compressor control status	R	Input Register (Float)	5	comp_ctrl_status	AV	60		Select	Compressor Control Status 0 = Zone Control 1 = Discharge Air Control

See legend on page 73.

**Table 36 — Integration Points List (cont)**

PROTOCOL MAP		MODBUS		BACNET			LONWORKS		OPERATION
DISPLAY NAME	READ/ WRITE	REGISTER TYPE	REGISTER NUMBER	REFERENCE NAME	OBJECT TYPE	OBJECT ID	NV NAME	SNVT	DESCRIPTION
Compressor Stages	R	Input Register (Float)	7	cmp_stgs	AV	14	nvoCmpStgs	SNVT_count_inc(9)	Compressor Stages Configured Status 1 = 1 Compressor 1 Stage 2 = 2 Compressor 2 Stages 3 = 3 Compressor 3 Stages (3 and 4 Stage units only) 4 = 4 Compressor 4 Stages (50BV Default)
Compressors mode	R/W	Holding Register (Float)	11	comp_mode	AV	70		Select	Compressor Mode Setup 0 = Zone 1 = Discharge Air Control (Default)
CON	R	Discrete Input	24	con_2st	BV	9		Select	UPM Board 1 Condensate Alarm 0 = Normal 1 = Condensate Alarm
CON2	R	Discrete Input	25	con_4st	BV	57		Select	UPM Board 2 Condensate Alarm 0 = Normal 1 = Condensate Alarm
Condenser Valve Status	R	Discrete Input	26	cond_vlv_status	BV	105		Select	Condenser Valve Status (Closed to Enable Compressor Operation) 0 = Compressor Operation Disabled 1 = Compressor Operation Enabled
Continuous Fan	R/W	Coil	8	Cont_fan	BV	18		Select	Run Fan continuously During Occupancy Mode Setup 0 = Cycle Fan with Compressor Operation 1 = Run Fan when Occupied (Default)
Control Source	R/W	Holding Register (Float)	13	ctrl_source	AV	15		Select	Control Source for Occupancy Setup 0 = Digital Input 1 1 = Keypad Schedule 2 = BAS Occupancy Command 3 = Factory Use 4 = Manual On-Continuous (Default)
Cooling Econo	R	Discrete Input	27	clg_econ	BV	63		Select	Network Parameter to set Cooling Econo temperature 0 = Hardwired Sensor (Default) 1 = BAS Sensor Value
Cooling Percentage	R	Input Register (Float)	9	clg_pct	AV	13	nvoClgPct	SNVT_count_inc(9)	Network Status of Cooling Demand in percentage (%)
Cooling Set point	R/W	Holding Register (Float)	57	sat_stpt_cl	AV	66		Select	Network Parameter to set the Cooling Set point 55 °F (Default)
CSAT_HI	R	Discrete Input	28	csat_hi	BV	80		Select	Network Parameter to set CSAT HI 0 = Hardwired Sensor (Default) 1 = BAS Sensor Value
Current Alarm	R	Input Register (Float)	11	current_alarm	AV	17	nvoCurAlm	SNVT_count_inc(9)	Alarm Status of unit: 0 = No Alarm 1-7 = UPM1 Fault Code 9-16 = UPM2 Fault Code 20 = Output Overridden via Keypad 30 = Sensor Failure 40 = Leaving Water Temp Alarm 50 = Zone Temp Alarm 60 = Discharge Air Temperature 70 = Filter Alarm/Compressors 1 & 2 Runtime 90 = High CO2 Level Alarm 100 = Supply Fan Locked 110 = Static Press Low
CWV Command	R	Discrete Input	29	cwv_command	BV	109	nvoCwvCommand	SNVT_switch(95)	Condenser Water Valve Command Status 0 = Off 1 = On

See legend on page 73.

**Table 36 — Integration Points List (cont)**

PROTOCOL MAP		MODBUS		BACNET			LONWORKS		OPERATION
DISPLAY NAME	READ/ WRITE	REGISTER TYPE	REGISTER NUMBER	REFERENCE NAME	OBJECT TYPE	OBJECT ID	NV NAME	SNVT	DESCRIPTION
CWV_FAIL	R	Discrete Input	30	cwv_fail	BV	107		Select	Condenser Water Valve Failure Alarm
CWV_HAND	R	Discrete Input	31	cwv_hand	BV	108		Select	Condenser Hand Alarm Condenser Valve Command Enabled without unit commanded
DA_SENS_FAIL	R	Discrete Input	32	da_sen	BV	31		Select	Network Alarm Indicating Discharge Air Sensor Failure 0 = Normal 1 = Alarm
Damper Output Cmd	R	Discrete Input	33	damper_cmd	BV	49	nvoDamp-erCmd	SNVT_switch(95)	Damper Output Status 0 = Closed 1 = Open
DAT Sensor Selection	R/W	Holding Register (Float)	15	dat_sel	AV	81		Select	Discharge Air Temperature Sensor Setup 0 = Hardwired Sensor (Default) 1 = BAS Supplied DAT value
DAT Sensor Source Selection Status	R	Input Register (Float)	13	dat_sel_sta	AV	82		Select	Discharge Air Temperature Sensor Selection Status 0 = Hardwired Sensor DAT 1 = BAS Supplied DAT
DAT_HI	R	Discrete Input	34	dat_hi	BV	29		Select	Discharge Air Temperature Sensor Alarm (Cooling) 0 = Normal 1 = High DAT (Default: >70 °F)
Demand Level	R/W	Holding Register (Float)	17	demand_level	AV	64		Select	Demand Level Set point Adjust in °F
DO_LOCK	R	Discrete Input	35	do_lock	BV	37		Select	Network Parameter to set DO LOCK 0 = Hardwired Sensor (Default) 1 = BAS Sensor Value
DPS Alarm	R	Discrete Input	36	DPS_alarm	BV	77		Select	Network Parameter to set DPS Alarm 0 = Hardwired Sensor (Default) 1 = BAS Sensor Value
DX_RNTM	R	Discrete Input	37	dx_rntm	BV	79		Select	Network Parameter to set DX RNTM 0 = Hardwired Sensor (Default) 1 = BAS Sensor Value
Eff HGR Mod Valve 1	R	Input Register (Float)	15	eff_hgr_mod_vlv1	AV	28	nvoEffHgrMod-Vlv1	SNVT_lev_percent(81)	Hot Gas Reheat Modulating Valve Output Status in %
Eff RA Fan Speed	R	Input Register (Float)	45	eff_ra_fan_speed	AV	162	nvoEffRa-FanSpeed	SNVT_lev_percent(81)	Supply Air Fan Speed Network Status in %
Eff RA Static Pressure	R	Input Register (Float)	47	eff_ra_sta_press	AV	163	nvoEffRa-StaPress	SNVT_count_inc(9)	Network Status of the Supply Duct Static Pressure Sensor
Eff SA Fan Speed	R	Input Register (Float)	17	eff_sa_fan_speed	AV	55	nvoEffSa-FanSpeed	SNVT_lev_percent(81)	Supply Air Fan Speed Network Status in %
Eff SA Static Pressure	R	Input Register (Float)	19	eff_sa_sta_press	AV	53	nvoEffSa-StaPress	SNVT_press_p(113)	Network Status of the Supply Duct Static Pressure Sensor
Eff Zone Co2 Lev	R	Input Register (Float)	21	eff_zn_co2_lev	AV	25	nvoEffZn-Co2Lev	SNVT_count_inc(9)	Network Status of the CO2 Sensor Levels in PPM
Effect EW Temp	R	Input Register (Float)	23	eff_ewt	AV	62	nvoEffEwt	SNVT_temp_p(105)	Network Status of the Entering Water Temperature in °F
Effect Leaving Wtr Temp	R	Input Register (Float)	25	eff_lwt	AV	11	nvoEffLwt	SNVT_temp_p(105)	Network Status of the Entering Water Temperature in °F
Effect Outdoor Air Temp	R	Input Register (Float)	27	eff_rat	AV	75	nvoEffRat	SNVT_temp_p(105)	Network Status of the Return Air Temperature in °F
ELW_SENS_FAIL	R	Discrete Input	38	elw_sen	BV	72		Select	Network Parameter to set ELW sensor FAIL 0 = Hardwired Sensor (Default) 1 = BAS Sensor Value

See legend on page 73.

**Table 36 — Integration Points List (cont)**

PROTOCOL MAP		MODBUS		BACNET			LONWORKS		OPERATION
DISPLAY NAME	READ/ WRITE	REGISTER TYPE	REGISTER NUMBER	REFERENCE NAME	OBJECT TYPE	OBJECT ID	NV NAME	SNVT	DESCRIPTION
Enabled Stages	R	Input Register (Float)	29	enabled_cl- stages	AV	68		Select	Network Status of the number of Compressor Stages Enabled
Factory Test	R/W	Coil	14	fac_test_en- able	BV	91000		Select	Factory Reserved
Fan Mode Status	R	Input Register (Float)	31	fan_- mode_status	AV	51		Select	Network Status of the Fan Mode Selection 0 = Start / Stop Fan Operation 1 = Variable Frequency Drive Fan Operation
Fan Output Cmd	R	Discrete Input	39	fan_cmd	BV	17		Select	Network Parameter to set Fan Output Cmd 0 = Hardwired Sensor (Default) 1 = BAS Sensor Value
Fan_mode	R/W	Holding Regis- ter (Float)	19	fan_mode	AV	50		Select	Network Parameter to set Fan Mode of Opera- tion 1 = Standard Fan Con- figuration 2 = Variable Frequency Drive Configuration (VAV Default)
FILTER	R	Discrete Input	40	filter	BV	40		Select	Filter Status 0 = Normal 1 = Clean Filter
FRE	R	Discrete Input	41	frz_2st	BV	8		Select	UPM Board 1 Freeze Alarm 0 = Normal 1 = Active Freeze Con- dition
FRE2	R	Discrete Input	42	frz_4st	BV	56		Select	UPM Board 2 Freeze Alarm 0 = Normal 1 = Active Freeze Con- dition
High Static Count Rst	R/W	Coil	23	rtn_sup_st- c_ctr_rst	BV	99		Select	Network Parameter to reset the high static alarm counter Momen- tary toggle ON/OFF to reset counter
HP1	R	Discrete Input	43	hp1_2st	BV	5	nvoHp1Al arm	SNVT_switch(95)	UPM Board 1 High Pressure Alarm Status for Compressor 1 0 = Normal 1 = Active High Pres- sure 1 Alarm
HP2	R	Discrete Input	44	hp2_2st	BV	52	nvoHp2Al arm	SNVT_switch(95)	UPM Board 2 High Pressure Alarm Status for Compressor 3 0 = Normal 1 = Active High Pres- sure 3 Alarm
HP3	R	Discrete Input	45	hp3_3st	BV	7	nvoHp3Al arm	SNVT_switch(95)	UPM Board 1 High Pressure Alarm Status for Compressor 2 0 = Normal 1 = High Pressure 2 Alarm
HP4	R	Discrete Input	46	hp4_4st	BV	54	nvoHp4Al arm	SNVT_switch(95)	UPM Board 2 High Pressure Alarm Status for Compressor 4 0 = Normal 1 = High Pressure 4 Alarm
INPUT_LOCK	R	Discrete Input	47	input_lock	BV	38		Select	Network Parameter to set INPUT LOCK 0 = Hardwired Sensor (Default) 1 = BAS Sensor Value
Loop Enabled	R/W	Coil	9	loop_enabled	BV	23	nviLoopEn a	SNVT_switch(95)	Network Parameter to set Loop Enabled 0 = Hardwired Sensor (Default) 1 = BAS Sensor Value
LOW SP	R	Discrete Input	48	sta_- press_low	BV	81		Select	Network Parameter to set LOW SP 0 = Single LOW Value 1 = Multiple LOW Val- ues (Default)

See legend on page 73.

**Table 36 — Integration Points List (cont)**

PROTOCOL MAP		MODBUS		BACNET			LONWORKS		OPERATION
DISPLAY NAME	READ/ WRITE	REGISTER TYPE	REGISTER NUMBER	REFERENCE NAME	OBJECT TYPE	OBJECT ID	NV NAME	SNVT	DESCRIPTION
LP1	R	Discrete Input	49	lp1_2st	BV	4	nvoLp1Alarm	SNVT_switch(95)	UPM Board 1 Low Pressure Alarm Status for Compressor 1 0 = Normal 1 = LP1 Alarm Active
LP2	R	Discrete Input	50	lp2_2st	BV	53	nvoLp2Alarm	SNVT_switch(95)	UPM Board 2 Low Pressure Alarm Status for Compressor 3 0 = Normal 1 = LP3 Alarm Active
LP3	R	Discrete Input	51	lp3_3st	BV	6	nvoLp3Alarm	SNVT_switch(95)	UPM Board 1 Low Pressure Alarm Status for Compressor 2 0 = Normal 1 = LP2 Alarm Active
LP4	R	Discrete Input	52	lp4_4st	BV	55	nvoLp4Alarm	SNVT_switch(95)	UPM Board 2 Low Pressure Alarm Status for Compressor 4 0 = Normal 1 = LP4 Alarm Active
LVG_HI	R	Discrete Input	53	lvg_hi	BV	32		Select	Leaving Water Temperature Alarm (High) 0 = Normal 1 = High LWT Alarm Active (Default: >135 °F)
LVG_LO	R	Discrete Input	54	lvg_lo	BV	33		Select	Leaving Water Temperature (LWT) Alarm (Low) 0 = Normal 1 = Low LWT Alarm Active (Default: <33 °F)
LVG_SENS_FAIL	R	Discrete Input	55	lvg_sen	BV	34		Select	Leaving Water Temperature Alarm (Sensor) 0 = Normal 1 = Sensor Failure (Check Sensor Hardware Configuration)
Mode Status	R	Input Register (Float)	33	mode_status	AV	24	nvoModeStatus	SNVT_count_inc(9)	Unit Mode of Operation Selection Status 0 = Cooling only 5 = Cooling + Hot Gas Re-Heat
OAT Reset	R/W	Holding Register (Float)	21	oat_reset1	AV	80	nviOatReset1	SNVT_count_inc(9)	Outside Air Temperature (Free Cooling) Operation in °F Default: 50 °F
OAT Reset 2	R/W	Holding Register (Float)	23	oat_reset2	AV	72	nviOatReset2	SNVT_count_inc(9)	Outside Air Temperature (Stage 1 Cooling) Operation in °F Default: 60 °F
OAT Reset 3	R/W	Holding Register (Float)	25	oat_reset3	AV	74	nviOatReset3	SNVT_count_inc(9)	Outside Air Temperature (Stage 2 Cooling) Operation in °F Default: 70 °F
OAT Reset 4	R/W	Holding Register (Float)	27	oat_reset4	AV	76	nviOatReset4	SNVT_count_inc(9)	Outside Air Temperature (Stage 3 Cooling) Operation in °F Default: 78 °F
OAT Reset 5	R/W	Holding Register (Float)	29	oat_reset5	AV	79	nviOatReset5	SNVT_count_inc(9)	Outside Air Temperature (Stage 4 Cooling) Operation in °F Default: 84 °F
OAT Reset MA	R/W	Holding Register (Float)	31	oat_reset_ht	AV	92		Select	Outside Air Mixed Air Temperature (Pre-Heating) Operation in °F Default: 40 °F
Occupancy Status	R	Discrete Input	56	occ_status	BV	21	nvoOccStatus	SNVT_switch(95)	Network Parameter to set Occupancy Status 0 = Hardwired Sensor (Default) 1 = BAS Sensor Value
Outside Air Reset Mode Status	R	Input Register (Float)	37	oat_rst_mode_stat	AV	89		Select	Return Air Temperature Reset Mode Status 0 = Single 1 = Multiple
Overload	R	Discrete Input	57	blwr_overload_alm	BV	75		Select	Network Alarm of Supply Fan Motor Overload 0 = Normal 1 = Motor Overload Alarm

See legend on page 73.

**Table 36 — Integration Points List (cont)**

PROTOCOL MAP		MODBUS		BACNET			LONWORKS		OPERATION
DISPLAY NAME	READ/ WRITE	REGISTER TYPE	REGISTER NUMBER	REFERENCE NAME	OBJECT TYPE	OBJECT ID	NV NAME	SNVT	DESCRIPTION
Overload Status	R	Discrete Input	58	blw_ovr-load_status	BV	74		Select	Network Status of Supply Fan Motor Overload 0 = Normal 1 = Motor Overload Alarm
Point Name	R/W	Holding Register (Float)	53	ao_two	AV	92002		Select	Factory Reserved
Point Name	R/W	Holding Register (Float)	55	ao_one	AV	92001		Select	Factory Reserved
Point Name	R/W	Coil	13	do_one	BV	91001		Select	Factory Reserved
Point Name	R/W	Coil	15	do_two	BV	91002		Select	Factory Reserved
Point Name	R/W	Coil	16	do_three	BV	91003		Select	Factory Reserved
Point Name	R/W	Coil	17	do_six	BV	91006		Select	Factory Reserved
Point Name	R/W	Coil	18	do_five	BV	91005		Select	Factory Reserved
Point Name	R/W	Coil	19	do_four	BV	91004		Select	Factory Reserved
Point Name	R/W	Coil	20	do_one_one	BV	91007		Select	Factory Reserved
Point Name	R/W	Coil	21	do_one_-three	BV	91009		Select	Factory Reserved
Point Name	R/W	Coil	22	do_one_two	BV	91008		Select	Factory Reserved
RA High Static	R	Discrete Input	76	raf_hi_stat-ic_alm	BV	96	nvoRafHi-StaticAl	SNVT_switch(95)	Network Alarm indicating return high return duct static 0 = Normal 1 = High Static Alarm
RA Static Press High Trip	R/W	Holding Register (Float)	59	ra_sta_hi_trip	AV	164	nviRaSta-HiTrip	SNVT_count_inc(9)	Network Alarm indicating status of high levels of static
RA Static Press Set point	R/W	Holding Register (Float)	61	ra_sta_-press_stpt	AV	165	nviRaSta-PressStp	SNVT_count_inc(9)	Network Alarm indicating status of press levels of static
RA_SENS_FAIL	R	Discrete Input	71	ras_sen	BV	84		Select	Network Parameter to set RA SENSOR FAIL 0 = Hardwired Sensor (Default) 1 = BAS Sensor Value
RAS_HI	R	Discrete Input	72	ras_hi	BV	83		Select	Network Parameter set RAS HI 0 = Hardwired Sensor (Default) 1 = BAS Sensor Value
RAT Reset Mode	R/W	Holding Register (Float)	33	rat_rst_mode	AV	71		Select	Network Parameter to set Return Air Temperature reset mode 0 = Single Reset Value 1 = Multiple Reset Values (Default)
RAT Reset Selection	R/W	Holding Register (Float)	35	rat_sel	AV	73		Select	Network Parameter to set Return Air Temperature Selection 0 = Hardwired Sensor (Default) 1 = BAS Sensor Value
RAT Select	R	Input Register (Float)	35	rat_sel_sta	AV	78		Select	Network Parameter to set Return Air Temperature Select 0 = Single RAT Value 1 = Multiple RAT Values (Default)
RAT SENS FAIL	R	Discrete Input	59	rat_sen	BV	73		Select	Return Air Temperature Sensor Alarm 0 = Normal 1 = Sensor Failure (Check Sensor)
RAT_HI	R	Discrete Input	60	rat_hi	BV	78		Select	Return Air Temperature Sensor Alarm 0 = Normal 1 = Sensor Value > 120°F
Reset Fan Rntm	R/W	Coil	10	fan_rntm_rst	BV	19		Select	Reset Fan Runtime. Momentary On/Off required. Toggled upon filter change.
Return Air Fan min speed	R/W	Holding Register (Float)	63	raf_min_-speed	AV	166		Select	Network Parameter to set Return Air Temperature fan min speed 0 = Single min Value 1 = Multiple min Values (Default)

See legend on page 73.

**Table 36 — Integration Points List (cont)**

PROTOCOL MAP		MODBUS		BACNET			LONWORKS		OPERATION
DISPLAY NAME	READ/ WRITE	REGISTER TYPE	REGISTER NUMBER	REFERENCE NAME	OBJECT TYPE	OBJECT ID	NV NAME	SNVT	DESCRIPTION
Return Fan Output Cmd	R	Discrete Input	73	rtn_fan_cmd	BV	82	nvoRtnFanCmd	SNVT_switch(95)	Network Parameter to set the return air fan minimum speed 40% (Factory Default)
Rev Valve Output Cmd	R	Discrete Input	61	rev_vlv_cmd	BV	15		Select	Network Status of the Rev valve output
RF Overload	R	Discrete Input	74	rblwr_ovrload_alm	BV	86		Select	Network Alarm indicating return fan motor overload trip 0 = Normal 1 = Overload Alarm
RF Overload Status	R	Discrete Input	75	rtn_blw_ovrload_status	BV	98		Select	Network Status indicating return fan motor overload trip 0 = Normal 1 = Overload Alarm
RH Sensor Sel	R/W	Holding Register (Float)	37	rh_sensor_sel	AV	57		Select	Network Parameter to set RH sensor 0 = Single sensor Value 1 = Multiple sensor Values (Default)
SA Static Press High Trip	R/W	Holding Register (Float)	39	sa_sta_hi_trip	AV	54		Select	Network Parameter to set the high static pressure trip point Default 3.0 " of H2O
SA_CFG	R	Discrete Input	62	sa_config_error	BV	90		Select	Network Alarm indicating Smoke detector configuration Error
SA_SENS_FAIL	R	Discrete Input	63	sas_sen	BV	65		Select	Network Status Indicating Supply Static Pressure Sensor Failure 0 = Normal 1 = Sensor Failed
SAS_HI	R	Discrete Input	64	sas_hi	BV	64	nvoSasHi	SNVT_switch(95)	Static Air Pressure Alarm (High) 0 = Normal 1 = High Static Pressure (Default: 3.0" H2O)
Smk Det Alarm	R	Discrete Input	65	smoke	BV	89	nvoSmoke	SNVT_switch(95)	Smoke Detector Alarm 0 = Normal 1 = Alarm
Smoke Detector Status	R	Discrete Input	66	smoke_status	BV	87		Select	Network Status of Smoke Detector 0 = Normal 1 = Smoke Alarm
Static Shutdown	R	Discrete Input	77	sa_stc_shtdwn	BV	16		Select	Network Alarm indicating return high supply duct static 0 = Normal 1 = High Static Alarm
Static Press Set point	R/W	Holding Register (Float)	41	sta_press_stpt	AV	52	nviStaPressStpt	SNVT_press_p(113)	Network Parameter to set the Duct Static Pressure Set point in inches of H2O Setup
Static Pressure Shutdown	R/W	Holding Register (Float)	43	st_press_trip	AV	69		Select	Network Parameter to set Static Pressure Shutdown trip 0 = Single Pressure Value 1 = Multiple Pressure Values (Default)
Supply Air Temperature	R	Input Register (Float)	39	eff_sat	AV	10	nvoEffSATemp	SNVT_temp_p(105)	Network Parameter to set Supply Air Temperature 0 = Hardwired Sensor (Default) 1 = BAS Sensor Value
Supply Air Set Point Trip	R/W	Holding Register (Float)	45	sat_hi_trip	AV	63		Select	Network Parameter to set Supply Air Set point trip 0 = Single Set point Value 1 = Multiple Set point Values (Default)
Supply Air Set Point Differential	R/W	Holding Register (Float)	47	sat_stpt_diff	AV	65		Select	Network Parameter set Supply Air Set point differential 0 = Single Set point Value 1 = Multiple Set point Values (Default)

See legend on page 73.



**Table 36 — Integration Points List (cont)**

PROTOCOL MAP		MODBUS		BACNET			LONWORKS		OPERATION
DISPLAY NAME	READ/ WRITE	REGISTER TYPE	REGISTER NUMBER	REFERENCE NAME	OBJECT TYPE	OBJECT ID	NV NAME	SNVT	DESCRIPTION
Supply Air Temp Set Point	R	Input Register (Float)	41	sa_setpt	AV	31	nviSAtStpt	SNVT_-temp_p(105)	Network Parameter to set Supply Air Temperature Set point 0 = Hardwired Sensor (Default) 1 = BAS Sensor Value
System Status	R	Input Register (Float)	43	sys_status	AV	16	nvoSys-Status	SNVT_count_inc(9)	General System Status 0 = Unoccupied 1 = Occupied 2 = Fan Only 4 = Cooling 5 = Transition to Cool 10 = Re-Heat
Unit_mode	R/W	Holding Register (Float)	49	unit_mode	AV	23		Select	Network Parameter to configure Unit operating mode 0 = Cooling only 5 = Cooling + Hot Gas Re-Heat
UPM INPUT	R	Discrete Input	67	upm_input	BV	39		Select	UPM Input Failure Alarm - Board 1 0 = UPM Connected 1 = UPM Connection Failure
UPM INPUT	R	Discrete Input	68	upm2_input	BV	59		Select	UPM Input Failure Alarm - Board 1 0 = UPM Connected 1 = UPM Connection Failure
UPM Reset	R/W	Coil	11	upm_rst	BV	25		Select	UPM Board 1 Reset. Momentary On/Off required.
UPM Reset	R/W	Coil	12	upm2_rst	BV	60		Select	UPM Board 2 Reset. Momentary On/Off required.
ZN_CO2_fail	R	Discrete Input	69	zn_co2_fail	BV	51		Select	CO2 Zone Sensor Alarm (Sensor) 0 = Normal 1 = Sensor Failure (Check Sensor Hardware)
ZN_CO2_HI	R	Discrete Input	70	zn_co2_hi	BV	48		Select	CO2 Zone Sensor Alarm (High) 0 = Normal 1 = High CO2 Level (Default: >1995 PPM)
Zone Co2 High Trip	R/W	Holding Register (Float)	51	zn_co2_hi_trip	AV	27		Select	Network Alarm indicating status of high levels of CO2

**LEGEND**

**BAS** — Building Automaton System  
**DAT** — Discharge Air Temperature  
**LWT** — Leaving Water Temperature  
**R** — Read  
**UPM** — Unit Protection Module  
**W** — Write



# START-UP CHECKLIST

(Fill out this form on Start-Up and file in job folder)

**NOTE: To avoid injury to personnel and damage to equipment or property when completing the procedures listed in this start-up checklist, use good judgment, follow safe practices, and adhere to the safety considerations/information as outlined in preceding sections of this Installation, Start-Up, Service and Controls Operation and Troubleshooting document.**

## I. PRELIMINARY INFORMATION:

50BV UNIT: MODEL NO. \_\_\_\_\_ SERIAL NO. \_\_\_\_\_

START-UP DATE: \_\_\_\_\_

## II. PRE-START-UP:

VERIFY ALL SHIPPING MATERIALS HAVE BEEN REMOVED FROM THE UNIT

IS THERE ANY SHIPPING DAMAGE? \_\_\_\_\_ IF SO, WHERE \_\_\_\_\_

\_\_\_\_\_

WILL THIS DAMAGE PREVENT UNIT START-UP? (Y/N) \_\_\_\_\_

CHECK POWER SUPPLY. DOES IT AGREE WITH UNIT? (Y/N) \_\_\_\_\_

HAS THE GROUND WIRE BEEN CONNECTED? (Y/N) \_\_\_\_\_

HAS THE CIRCUIT PROTECTION BEEN SIZED AND INSTALLED PROPERLY? (Y/N) \_\_\_\_\_

ARE THE POWER WIRES TO THE UNIT SIZED AND INSTALLED PROPERLY? (Y/N) \_\_\_\_\_

HAS THE CORRECT INPUT POWER PHASE SEQUENCE BEEN CONFIRMED WITH A METER? (Y/N) \_\_\_\_\_

HAS THE FAN AND MOTOR PULLEY BEEN CHECKED FOR PROPER ALIGNMENT AND DOES THE FAN BELT HAVE PROPER TENSION? (Y/N) \_\_\_\_\_

HAS WATER BEEN PLACED IN DRAIN PAN TO CONFIRM PROPER DRAINAGE? (Y/N) \_\_\_\_\_

ARE PROPER AIR FILTERS IN PLACE AND CLEAN? (Y/N) \_\_\_\_\_

VERIFY THAT THE UNIT IS INSTALLED WITHIN LEVELING TOLERANCES (Y/N) \_\_\_\_\_

### CONTROLS

HAS THE DUCT STATIC PRESSURE PROBE BEEN INSTALLED? (Y/N) \_\_\_\_\_

HAVE CONTROL CONNECTIONS BEEN MADE AND CHECKED? (Y/N) \_\_\_\_\_

ARE ALL WIRING TERMINALS (including main power supply) TIGHT? (Y/N) \_\_\_\_\_

HAS AUTOMATIC RUN TEST BEEN COMPLETED? (Y/N) \_\_\_\_\_

HAS THE VFD CHECKOUT BEEN COMPLETED? (Y/N) \_\_\_\_\_

### PIPING

HAVE LEAK CHECKS BEEN MADE AT COMPRESSOR, CONDENSER, EVAPORATOR, TXVs (Thermostatic Expansion Valves), SOLENOID VALVES, FILTER DRIERS, AND FUSIBLE PLUGS WITH A LEAK DETECTOR? (Y/N) \_\_\_\_\_

HAVE WATER AND STEAM VALVES BEEN OPENED (to fill piping and heat exchangers)? (Y/N) \_\_\_\_\_

HAS AIR PURGE BEEN PERFORMED? (Y/N) \_\_\_\_\_

**ELECTRICAL**

CHECK VOLTAGE IMBALANCE

LINE-TO-LINE VOLTS: AB \_\_\_\_\_ V AC \_\_\_\_\_ V BC \_\_\_\_\_ V

(AB + AC + BC)/3 = AVERAGE VOLTAGE = \_\_\_\_\_ V

MAXIMUM DEVIATION FROM AVERAGE VOLTAGE = \_\_\_\_\_ V

VOLTAGE IMBALANCE = 100 X (MAX DEVIATION)/(AVERAGE VOLTAGE) = \_\_\_\_\_ % (IF OVER 2% VOLTAGE IMBALANCE, DO NOT ATTEMPT TO START SYSTEM; CALL LOCAL POWER COMPANY FOR ASSISTANCE.)

**III. START-UP:**

CHECK FAN SPEED AND RECORD. \_\_\_\_\_

AFTER AT LEAST 15 MINUTES RUNNING TIME, RECORD THE FOLLOWING MEASUREMENTS:

	CIRCUIT 1	CIRCUIT 2	CIRCUIT 3	CIRCUIT 4
SUCTION PRESSURE	_____	_____	_____	_____
SATURATED SUCTION TEMP	_____	_____	_____	_____
SUCTION LINE TEMP	_____	_____	_____	_____
SUPERHEAT DEGREES	_____	_____	_____	_____
DISCHARGE PRESSURE	_____	_____	_____	_____
SATURATED CONDENSING	_____	_____	_____	_____
LIQUID LINE TEMP	_____	_____	_____	_____
SUBCOOLING DEGREES	_____	_____	_____	_____
LIQUID SIGHT GLASS (CLEAR/BUBBLES)	_____	_____	_____	_____
ENTERING CONDENSER-WATER TEMP	_____	_____	_____	_____
LEAVING CONDENSER-WATER TEMP	_____	_____	_____	_____
EVAP ENTERING-AIR DB (dry bulb) TEMP	_____	_____	_____	_____
EVAP ENTERING-AIR WB (wet bulb) TEMP	_____	_____	_____	_____
EVAP LEAVING-AIR DB TEMP	_____	_____	_____	_____
EVAP LEAVING-AIR WB TEMP	_____	_____	_____	_____

COMPRESSOR AMPS:

L1	_____	_____	_____	_____
L2	_____	_____	_____	_____
L3	_____	_____	_____	_____

SUPPLY FAN AMPS:

L1	_____	_____
L2	_____	_____
L3	_____	_____

NOTES: \_\_\_\_\_  
\_\_\_\_\_  
\_\_\_\_\_  
\_\_\_\_\_

CUT ALONG DOTTED LINE

CUT ALONG DOTTED LINE