



Installation Instructions

50HC units for installation in the United States contain use of Carrier's Staged Air Volume (SAV™) 2-speed indoor fan control system. This complies with the U.S. Department of Energy (DOE) efficiency standard of 2018.

50HC units for installation outside the United States may or may not contain use of the SAV 2-speed indoor fan control system as they are not required to comply with the U.S. Department of Energy (DOE) efficiency standard of 2018.

For specific details on operation of the Carrier SAV 2-speed indoor fan system refer to the Variable Frequency Drive (VFD) Factory-Installed Option 2-Speed Motor Control Installation, Setup, and Troubleshooting manual.

CONTENTS

	Page
SAFETY CONSIDERATIONS	1-6
Rated Indoor Airflow (cfm)	2
INSTALLATION	6-63
Jobsite Survey	6
Step 1 — Plan for Unit Location	6
Step 2 — Plan for Sequence of Unit Installation	6
Step 3 — Inspect Unit	7
Step 4 — Provide Unit Support	7
Step 5 — Field Fabricate Ductwork	9
Step 6 — Rig and Place Unit	9
Step 7 — Convert to Horizontal and Connect Ductwork	11
Step 8 — Install Outside Air Hood	11
Step 9 — Install External Condensate Trap and Line	13
Step 10 — Make Electrical Connections	13
Electric Heaters	21
Single Point Boxes	21
Humidi-MiZer® System Control Connections	22
EconoMiSer® X (Factory-Installed Option)	24
Low Ambient Control (Factory Option)	37
Staged Air Volume (SAV) with Variable Frequency Drive (Factory Option)	37
ComfortLink Controls (Factory Option)	37
PremierLink Controller (Factory Option)	42
Supply Air Temperature Sensor	45
Field Connections	45
Economizer Controls	48
RTU Open Control System	52
Field Connections	56
Communication Wiring — Protocols	58
Local Access	59
Outdoor Air Enthalpy Control	60
Smoke Detectors	61
Step 11 — Adjust Factory-Installed Options	62
Step 12 — Install Accessories	62
Pre-Start and Start-up	62
START-UP CHECKLIST	CL-1, CL-2

SAFETY CONSIDERATIONS

Improper installation, adjustment, alteration, service, maintenance, or use can cause explosion, fire, electrical shock or other conditions which may cause personal injury or property damage. Consult a qualified installer, service agency, or your distributor or branch for information or assistance. The qualified installer or agency must use factory-authorized kits or accessories when modifying this product. Refer to the individual instructions packaged with the kits or accessories when installing.

Follow all safety codes. Wear safety glasses and work gloves. Use quenching cloths for brazing operations and have a fire extinguisher available. Read these instructions thoroughly and follow all warnings or cautions attached to the unit. Consult local building codes and appropriate national electrical codes (in USA, ANSI/NFPA 70, National Electrical Code (NEC); in Canada, CSA C22.1) for special requirements.

It is important to recognize safety information. This is the safety-alert symbol . When you see this symbol on the unit and in instructions or manuals, be alert to the potential for personal injury.

Understand the signal words DANGER, WARNING, CAUTION, and NOTE. These words are used with the safety-alert symbol. DANGER identifies the most serious hazards which **will** result in severe personal injury or death. WARNING signifies hazards which **could** result in personal injury or death. CAUTION is used to identify unsafe practices, which **may** result in minor personal injury or product and property damage. NOTE is used to highlight suggestions which **will** result in enhanced installation, reliability, or operation.

WARNING

ELECTRICAL SHOCK HAZARD

Failure to follow this warning could cause personal injury or death.

Before performing service or maintenance operations on unit, always turn off main power switch to unit and install lock(s) and lockout tag(s). Unit may have more than one power switch.

⚠ WARNING

UNIT OPERATION AND SAFETY HAZARD

Failure to follow this warning could cause personal injury, death and/or equipment damage.

Puron® (R-410A) refrigerant systems operate at higher pressures than standard R-22 systems. Do not use R-22 service equipment or components on Puron refrigerant equipment.

⚠ WARNING

PERSONAL INJURY AND ENVIRONMENTAL HAZARD

Failure to follow this warning could cause personal injury or death.

Relieve pressure and recover all refrigerant before system repair or final unit disposal.

Wear safety glasses and gloves when handling refrigerants. Keep torches and other ignition sources away from refrigerants and oils.

⚠ CAUTION

CUT HAZARD

Failure to follow this caution may result in personal injury.

Sheet metal parts may have sharp edges or burrs. Use care and wear appropriate protective clothing, safety glasses and gloves when handling parts and servicing air-conditioning equipment.

Rated Indoor Airflow (cfm) — The table below lists the rated indoor airflow used for the AHRI efficiency rating for the units covered in this document.

MODEL NUMBER	FULL LOAD AIRFLOW (CFM)
50HC*D/E/G14	4375

Position:	1	2	3	4	5	6	7	8	9	10	11	12	13	14	15	16	17	18
Example:	5	0	H	C	B	D	1	4	A	2	A	6	A	0	A	3	B	0

Unit Heat Type

50 - Electric Heat
Packaged Rooftop

Model Series - WeatherMaster®

HC - High Efficiency

Heat Options

- - None (Field Installed Accessory)
- A = Low Electric Heat
- B = Medium Electric Heat
- C = High Electric Heat

Refrig. Systems Options

- D = Two stage cooling models
- E = Two stage cooling models with Humidi-MiZer
- G = Two stage cooling models with MotorMaster Low Ambient Controller

Cooling Tons

14 - 12.5 ton

Sensor Options

- A = None
- B = RA Smoke Detector
- C = SA Smoke Detector
- D = RA + SA Smoke Detector
- E = CO₂
- F = RA Smoke Detector and CO₂
- G = SA Smoke Detector and CO₂
- H = RA + SA Smoke Detector and CO₂

Indoor Fan Options

- 1 = Standard Static Option - Belt Drive
- 2 = Medium Static Option - Belt Drive
- C = High Static Option with High Efficiency Motor - Belt Drive

Coil Options (RTPF) (Outdoor - Indoor - Hail Guard)

- A = Al/Cu - Al/Cu
- B = Precoat Al/Cu - Al/Cu
- C = E-coat Al/Cu - Al/Cu
- D = E-coat Al/Cu - E-coat Al/Cu
- E = Cu/Cu - Al/Cu
- F = Cu/Cu - Cu/Cu
- M = Al/Cu -Al/Cu — Louvered Hail Guard
- N = Precoat Al/Cu - Al/Cu — Louvered Hail Guard
- P = E-coat Al/Cu - Al/Cu — Louvered Hail Guard
- Q = E-coat Al/Cu - E-coat Al/Cu — Louvered Hail Guard
- R = Cu/Cu - Al/Cu — Louvered Hail Guard
- S = Cu/Cu - Cu/Cu — Louvered Hail Guard

Voltage

- 1 = 575/3/60
- 5 = 208-230/3/60
- 6 = 460/3/60

Design Revision

- A = Factory Design Revision

Factory Assigned

- 0 = Standard
- 1 = LTL

Electrical Options

- A = None
- B = HACR Breaker
- C = Non-Fused Disconnect
- D = Thru-The-Base Connections
- E = HACR and Thru-The-Base Connections
- F = Non-Fused Disconnect and Thru-The-Base Connections
- G = 2-Speed Indoor Fan (VFD) Controller
- H = 2-Speed Fan Controller (VFD) and HACR
- J = 2-Speed Fan Controller (VFD) and Non-Fused Disconnect
- K = 2-Speed Fan Controller (VFD) and Thru-The-Base Connections
- L = HACR w/ Thru-The-Base & 2-Speed Fan Controller (VFD)
- M = 2-Speed Fan Controller (VFD) with Non-Fused Disconnect and Thru-The-Base Connections

Service Options

- 0 = None
- 1 = Unpowered Convenience Outlet
- 2 = Powered Convenience Outlet
- 3 = Hinged Panels
- 4 = Hinged Panels and Unpowered Convenience Outlet
- 5 = Hinged Panels and Powered Convenience Outlet
- C = Foil Faced Insulation
- D = Foil Faced Insulation with Unpowered Convenience Outlet
- E = Foil Faced Insulation with Powered Convenience Outlet
- F = Foil Faced Insulation & Hinged Panels
- G = Foil Faced Insulation & Hinged Panels with Unpowered Convenience Outlet
- H = Foil Faced Insulation & Hinged Panels with Powered Convenience Outlet

Intake / Exhaust Options

- A = None
- B = Temperature Economizer w/ Barometric Relief
- F = Enthalpy Economizer w/ Barometric Relief
- K = 2-Position Damper
- U = Low Leak Temperature Economizer w/ Barometric Relief
- W = Low Leak Enthalpy Economizer w/ Barometric Relief

Base Unit Controls

- 0 = Electro-mechanical Controls Can be used with W7212 EconoMi\$er IV (Non-Fault Detection and Diagnostic)
- 1 = PremierLink Controller
- 2 = RTU Open Multi-Protocol Controller
- 6 = Electro-mechanical with 2-speed fan and W7220 Econo controller Controls. Can be used with W7220 EconoMi\$er X (with Fault Detection and Diagnostic)
- D = ComfortLink Controls

Fig. 1 — 50HC 14 Model Number Nomenclature (Example)

UNIT	STD. UNIT WEIGHT		CORNER WEIGHT (A)		CORNER WEIGHT (B)		CORNER WEIGHT (C)		CORNER WEIGHT (D)		C.G.					
	LBS.	KG.	LBS.	KG.	LBS.	KG.	LBS.	KG.	LBS.	KG.	X	Y	Z			
50HC 14	1360	617	335	151	363	164	344	156	320	145	60 1/8	152 7/8	31 1/8	71 1/8	21 1/8	153 3/8

STANDARD UNIT WEIGHT IS WITHOUT ELECTRIC HEAT & WITHOUT PACKAGING. FOR OPTIONS & ACCESSORIES, REFER TO THE PRODUCT DATA CATALOG.



UNITED TECHNOLOGIES SPRINGFIELD, CT
CORPORATION
13221

THIS DOCUMENT IS THE PROPERTY OF CARRIER CORPORATION AND IS DELIVERED UNDER THE EXPRESS CONDITION THAT THE USER SHALL NOT REPRODUCE OR TRANSMIT THIS INFORMATION IN ANY MANNER WITHOUT THE WRITTEN CONSENT OF CARRIER CORPORATION.

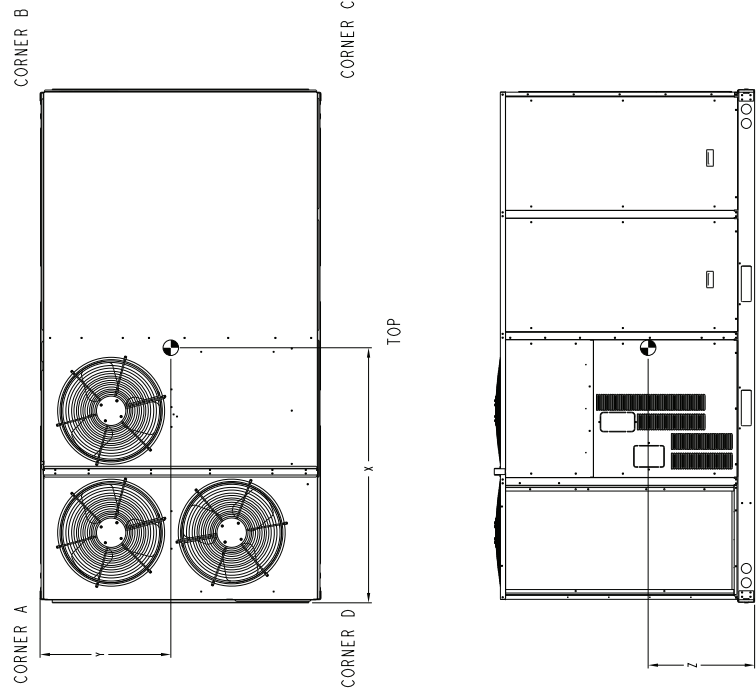

VERTICAL ECONOMIZER

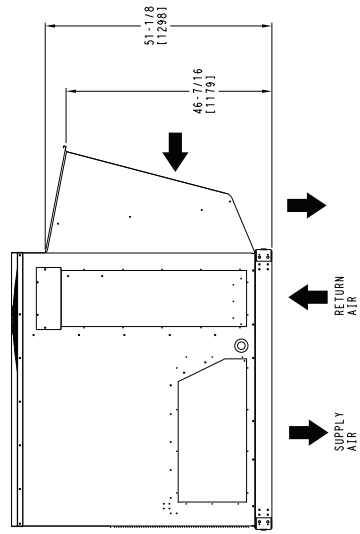
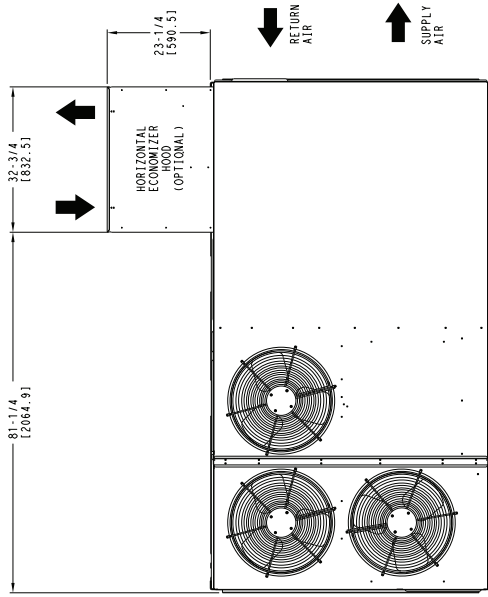

HORIZONTAL ECONOMIZER

DATE	SUPERCODES	50HC 14 SINGLE ZONE ELECTRICAL COOLING WITH ELECTRIC HEAT	REV
05/21/12	-	50TM501224	A

Fig. 2 — Unit Dimensional Drawing — 14 Size Unit (cont)

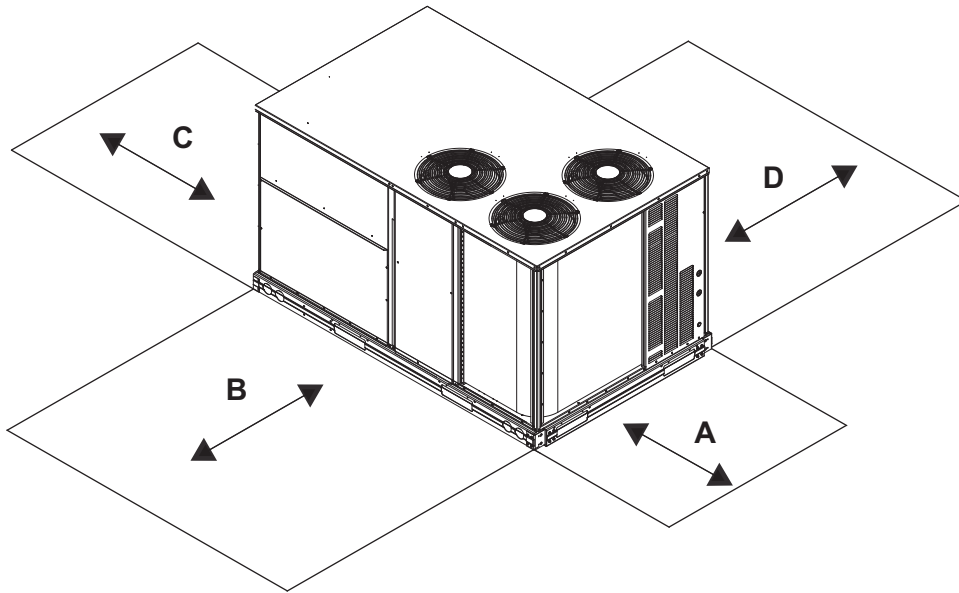

LOCATION	DIMENSION	CONDITION
A	48-in. (1219 mm) 18-in. (457 mm) 18-in. (457 mm) 12-in. (305 mm)	Unit disconnect is mounted on panel No disconnect, convenience outlet option Recommended service clearance Minimum clearance
B	42-in. (1067 mm) 36-in. (914 mm)	Surface behind servicer is grounded (e.g., metal, masonry wall) Surface behind servicer is electrically non-conductive (e.g., wood, fiberglass)
C	36-in. (914 mm) 18-in. (457 mm)	Side condensate drain is used Minimum clearance
D	42-in. (1067 mm) 36-in. (914 mm)	Surface behind servicer is grounded (e.g., metal, masonry wall, another unit) Surface behind servicer is electrically non-conductive (e.g., wood, fiberglass)

NOTE: Unit not designed to have overhead obstruction. Contact Application Engineering for guidance on any application planning overhead obstruction or for vertical clearances.

Fig. 3 — Service Clearance Dimensional Drawing

INSTALLATION

Jobsite Survey — Complete the following checks before installation.

1. Consult local building codes and the NEC (National Electrical Code) ANSI/NFPA 70 for special installation requirements.
2. Determine unit location (from project plans) or select unit location.
3. Check for possible overhead obstructions which may interfere with unit lifting or rigging.

Step 1 — Plan for Unit Location — Select a location for the unit and its support system (curb or other) that provides for at least the minimum clearances required for safety. This includes the clearance to combustible surfaces, unit performance and service access below, around and above unit as specified in unit drawings. See Fig. 3.

NOTE: Consider also the effect of adjacent units.

Unit may be installed directly on wood flooring or on Class A, B, or C roof-covering material when roof curb is used.

Do not install unit in an indoor location. Do not locate air inlets near exhaust vents, relief valves, or other sources of contaminated air.

Although unit is weatherproof, avoid locations that permit water from higher level runoff and overhangs to fall onto the unit.

Select a unit mounting system that provides adequate height to allow installation of condensate trap per requirements. Refer to Step 9 — Install External Condensate Trap and Line for required trap dimensions.

ROOF MOUNT — Check building codes for weight distribution requirements. Unit operating weight is shown in Table 1.

Table 1 — Operating Weights

50HC**14	
COMPONENT	UNITS LB (KG)
Base Unit	1360 (617)
Economizer	
Vertical	103 (47)
Horizontal	242 (110)
Humidi-MiZer System	90 (41)
Powered Outlet	35 (16)
Curb	
14-in. (356 mm)	180 (82)
24-in. (610 mm)	255 (116)

Step 2 — Plan for Sequence of Unit Installation — The support method used for this unit will dictate different sequences for the steps of unit installation. For example, on curb-mounted units, some accessories must be installed on the unit before the unit is placed on the curb. Review the following for recommended sequences for installation steps.

CURB-MOUNTED INSTALLATION

Install curb

Install field-fabricated ductwork inside curb

Install accessory thru-base service connection package (affects curb and unit) (refer to accessory installation instructions for details)

Prepare bottom condensate drain connection to suit planned condensate line routing (refer to Step 9 for details)

Rig and place unit

Install outdoor air hood

Install condensate line trap and piping

Make electrical connections

Install other accessories

PAD-MOUNTED INSTALLATION

Prepare pad and unit supports

Check and tighten the bottom condensate drain connection plug

Rig and place unit

Convert unit to side duct connection arrangement

Install field-fabricated ductwork at unit duct openings

Install outdoor air hood

Install condensate line trap and piping

Make electrical connections

Install other accessories

FRAME-MOUNTED INSTALLATION — Frame-mounted applications generally follow the sequence for a curb installation. Adapt as required to suit specific installation plan.

Step 3 — Inspect Unit — Inspect unit for transportation damage. File any claim with transportation agency.

Confirm before installation of unit that voltage, amperage and circuit protection requirements listed on unit data plate agree with power supply provided.

On units with hinged panel option, check to be sure all latches are snug and in closed position.

Locate the carton containing the outside air hood parts; see Fig. 11 and 12. Do not remove carton until unit has been rigged and located in final position.

Step 4 — Provide Unit Support

ROOF CURB MOUNT — Accessory roof curb details and dimensions are shown in Fig. 4. Assemble and install accessory roof curb in accordance with instructions shipped with the curb.

NOTE: The gasketing of the unit to the roof curb is critical for a watertight seal. Install gasket supplied with the roof curb as shown in Fig. 4. Improperly applied gasket can also result in air leaks and poor unit performance.

Curb should be level. This is necessary for unit drain to function properly. Unit leveling tolerances are shown in Fig. 5. Refer to Accessory Roof Curb Installation Instructions for additional information as required.

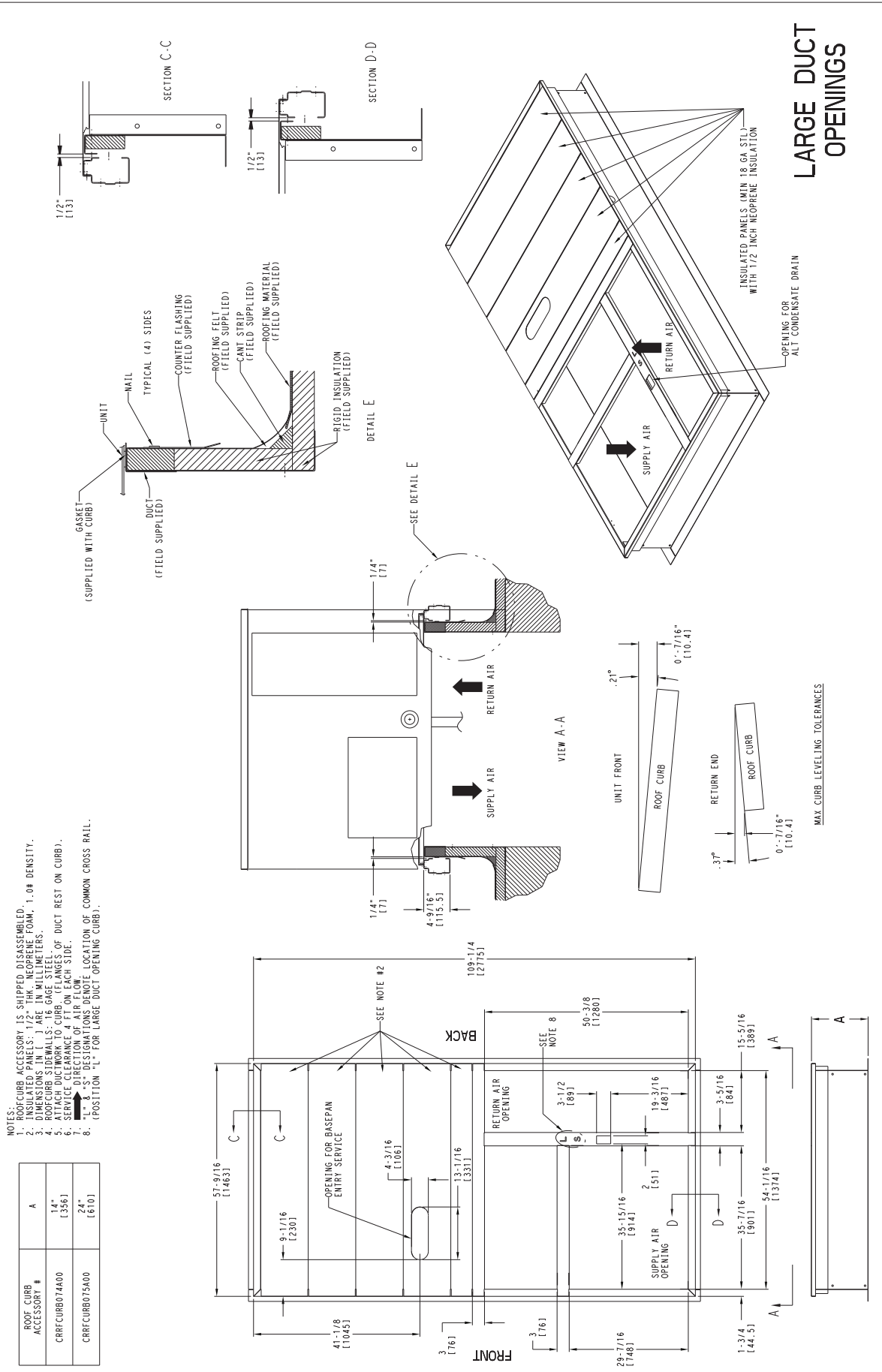

- NOTES:**
1. ROOF CURB ACCESSORY IS SHIPPED DISASSEMBLED.
 2. INSULATED PANELS: 1/2" THK. NEOPRENE FOAM, 1.0# DENSITY.
 3. INSULATED PANELS: 1/2" THK. NEOPRENE FOAM, 1.0# DENSITY.
 4. ROOF CURB SIDING: 16 GA. STEEL.
 5. ATTACH DUCTWORK TO CURB: (FLANGES OF DUCT REST ON CURB).
 6. SERVICE CLEARANCE: 4 FT. ON EACH SIDE.
 7. POSITION OF CURB: (SEE SECTION C-C FOR LOCATION OF COMMON CROSS RAIL).
 8. POSITION OF CURB: (SEE SECTION D-D FOR LARGE DUCT OPENING CURB).

ROOF CURB ACCESSORY #	A
CRFCURB074A00	14" [356]
CRFCURB075A00	24" [610]

Fig. 4 — Roof Curb Details

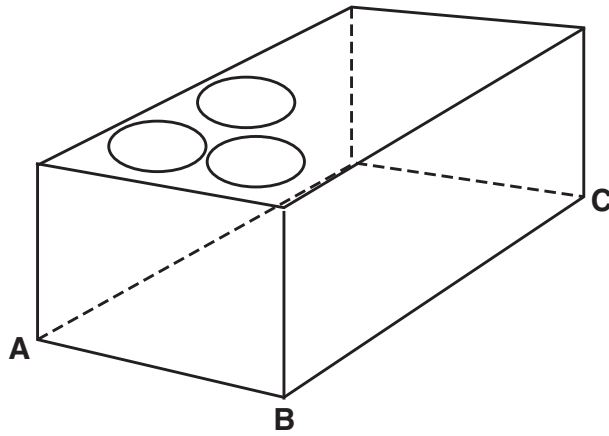

MAXIMUM ALLOWABLE DIFFERENCE IN. (MM)		
A-B	B-C	A-C
0.5" (13)	1.0" (25)	1.0" (25)

Fig. 5 — Unit Leveling Tolerances

Install insulation, cant strips, roofing felt, and counter flashing as shown. *Ductwork must be attached to curb and not to the unit.*

IMPORTANT: If the unit's electric and control wiring is to be routed through the basepan and the unit is equipped with the factory-installed Thru-the-Base service option see the following sections:

- Factory-Option Thru-Base Connections on page 19

If using the field-installed Thru-the-Base accessory follow the instructions provided with the accessory kit.

NOTE: If electrical connection is not going to occur at this time, tape or otherwise cover the fittings so that moisture does not get into the building or conduit in the interim.

SLAB MOUNT (HORIZONTAL UNITS ONLY) — Provide a level concrete slab that extends a minimum of 6 in. (150 mm) beyond unit cabinet. Install a gravel apron in front of condenser coil air inlet to prevent grass and foliage from obstructing airflow.

NOTE: Horizontal units may be installed on a roof curb if required.

ALTERNATE UNIT SUPPORT (IN LIEU OF CURB OR SLAB MOUNT) — A non-combustible sleeper rail can be used in the unit curb support area. If sleeper rails cannot be used, support the long sides of the unit with a minimum of 3 equally spaced 4-in. x 4-in. (102 mm x 102 mm) pads on each side.

Step 5 — Field Fabricate Ductwork

NOTE: Cabinet return-air static pressure (a negative condition) shall not exceed 0.35 in. wg (87 Pa) with economizer or 0.45 in. wg (112 Pa) without economizer.

For vertical ducted applications, secure all ducts to roof curb and building structure. *Do not connect ductwork to unit.*

Fabricate supply ductwork so that the cross sectional dimensions are equal to or greater than the unit supply duct opening dimensions for the first 18 in. (458 mm) of duct length from the unit basepan.

Insulate and weatherproof all external ductwork, joints, and roof openings with counter flashing and mastic in accordance with applicable codes.

Ducts passing through unconditioned spaces must be insulated and covered with a vapor barrier.

If a plenum return is used on a vertical unit, the return should be ducted through the roof deck to comply with applicable fire codes.

FOR UNITS WITH ACCESSORY OR OPTIONAL ELECTRIC HEATERS — All installations require a minimum clearance to combustible surfaces of 1-in. (25 mm) from duct for first 12-in. (305 mm) away from unit.

Outlet grilles must not lie directly below unit discharge.

NOTE: A 90-degree elbow must be provided in the ductwork to comply with UL (Underwriters Laboratories) code for use with electric heat.

⚠ WARNING

PERSONAL INJURY HAZARD

Failure to follow this warning could cause personal injury.

For vertical supply and return units, tools or parts could drop into ductwork and cause an injury. Install a 90-degree turn in the return ductwork between the unit and the conditioned space. If a 90-degree elbow cannot be installed, then a grille of sufficient strength and density should be installed to prevent objects from falling into the conditioned space. Due to electric heater, supply duct will require 90-degree elbow.

⚠ CAUTION

PROPERTY DAMAGE HAZARD

Failure to follow this caution may result in damage to roofing materials.

Membrane roofs can be cut by sharp sheet metal edges. Be careful when placing any sheet metal parts on such roof.

Step 6 — Rig and Place Unit — When the unit is ready to be rigged and no longer will be lifted by a fork truck, the wood protector under the basepan must be removed. Remove 4 screws from each base rail. Wood protector will drop to the ground. See instructions on the unit base rails.

Keep unit upright and do not drop. Spreader bars are required. Rollers may be used to move unit across a roof. Level by using unit frame as a reference. See Table 1 and Fig. 6 for additional information.

Lifting holes are provided in base rails as shown in Fig. 6. Refer to rigging instructions on unit.

⚠ CAUTION

UNIT DAMAGE HAZARD

Failure to follow this caution may result in equipment damage.

All panels must be in place when rigging. Unit is not designed for handling by fork truck when panels or packaging are removed.

Before setting the unit onto the curb, recheck gasketing on curb.

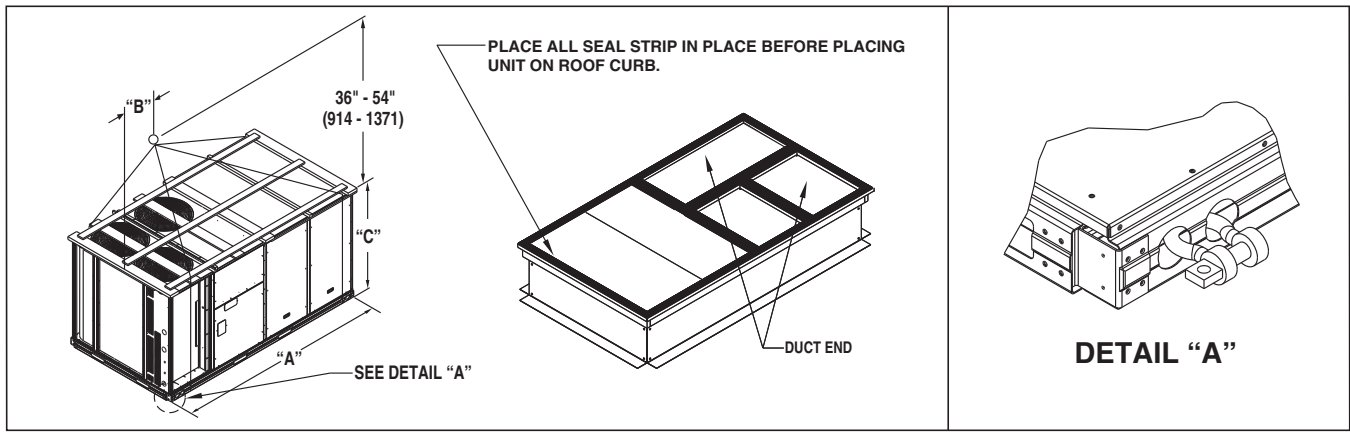

UNIT	MAX WEIGHT		DIMENSIONS					
			A		B		C	
	lb	kg	in.	mm	in.	mm	in.	mm
50HC**14	2105	957	116.0	2945	62.5	1590	59.5	1510

NOTES:

1. SPREADER BARS REQUIRED — Top damage will occur if spreader bars are not used.
2. Dimensions in () are in millimeters.
3. Hook rigging shackles through holes in base rail, as shown in detail "A." Holes in base rails are centered around the unit center of gravity. Use wooden top to prevent rigging straps from damaging unit.

Fig. 6 — Rigging Details

POSITIONING ON CURB — For full perimeter curbs CRRFCURB074A00 and 075A00, the clearance between the roof curb and the front and rear base rails should be $\frac{1}{4}$ in. (6.4 mm). The clearance between the curb and the end base rails should be $\frac{1}{2}$ in. (13 mm). For retrofit applications with curbs CRRFCURB003A01 and 4A01, the unit should be positioned as shown in Fig. 7. Maintain the 15.5 in. (394 mm) and $8\frac{5}{8}$ in. (220 mm) clearances and allow the $22\frac{5}{16}$ in. (567 mm) dimension to float if necessary.

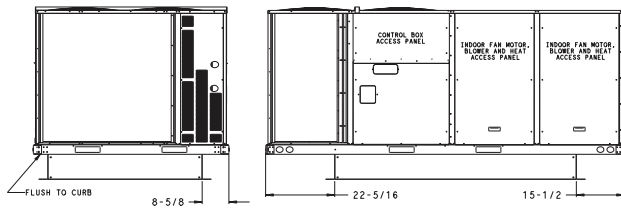

Fig. 7 — Retrofit Installation Dimensions

If the alternative condensate drain location through the bottom of the unit is used in conjunction with a retrofit curb, the hole in the curb must be moved 12.5 in. (320 mm) towards the end of the unit. (See Fig. 8.)

Although unit is weatherproof, guard against water from higher level runoff and overhangs.

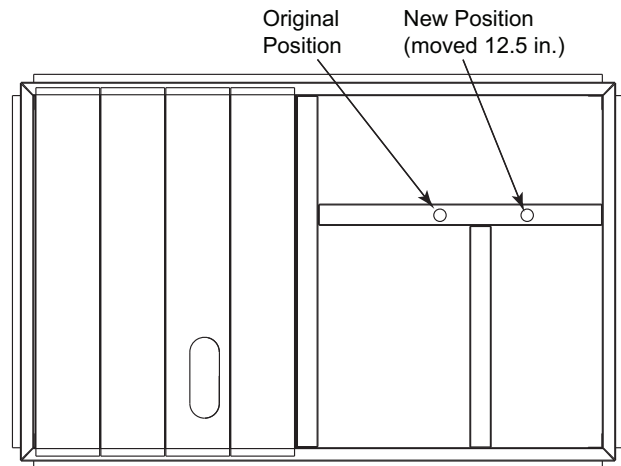

Fig. 8 — Alternative Condensate Drain Hole Positions

IMPORTANT: If the unit has the factory-installed Thru-Base option, make sure to complete installation of the option before placing the unit on the roof curb. See the following section:

- Factory-Option Thru-Base Connections on page 19

NOTE: If electrical connections are not going to occur at this time, tape or otherwise cover the fittings so that moisture does not get into the building or conduit in the interim.

Remove all shipping materials and top skid. Remove extra center post from the condenser end of the unit so that the condenser end of the unit matches Fig. 18-20. Recycle or dispose of all shipping materials.

Step 7 — Convert to Horizontal and Connect Ductwork (When Required) — Unit is shipped in the vertical duct configuration. Unit without factory-installed economizer or return air smoke detector option may be field-converted to horizontal ducted configuration using accessory CRDUCTCV002A00. To convert to horizontal configuration, remove screws from side duct opening covers and remove covers. See Fig. 9.

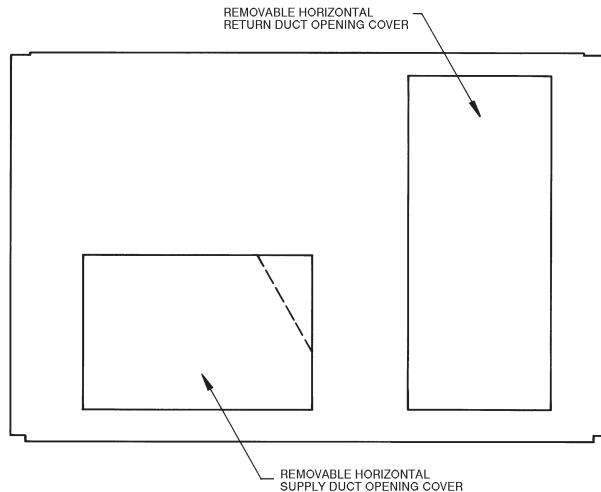

Fig. 9 — Horizontal Conversion Panels

Discard the supply duct cover. Install accessory CRDUCTCV002A00 to cover the vertical supply duct opening. Use the return duct cover removed from the end panel to cover the vertical return duct opening.

Field-supplied flanges should be attached to horizontal duct openings and all ductwork should be secured to the flanges. Insulate and weatherproof all external ductwork, joints, and roof or building openings with counter flashing and mastic in accordance with applicable codes.

Do not cover or obscure visibility to the unit's informative data plate when insulating horizontal ductwork.

Step 8 — Install Outside Air Hood

ECONOMIZER HOOD REMOVAL AND SETUP — FACTORY OPTION

1. The hood is shipped in knock-down form and located in the return air compartment. It is attached to the economizer using two plastic tie-wraps.
2. To gain access to the hood, remove the filter access panel. (See Fig. 10.)
3. Locate and cut the (2) plastic tie-wraps, being careful to not damage any wiring. (See Fig. 11.)
4. Carefully lift the hood assembly through the filter access opening and assemble per the steps outlined in Economizer Hood and Two-Position Hood on page 12.

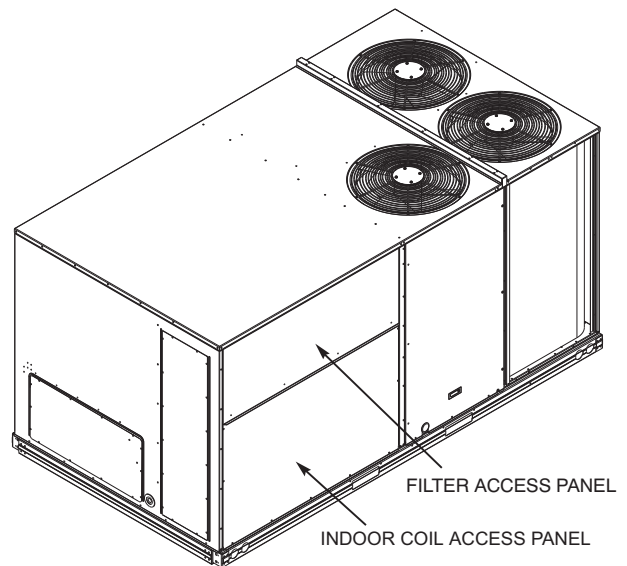

Fig. 10 — Typical Access Panel Locations

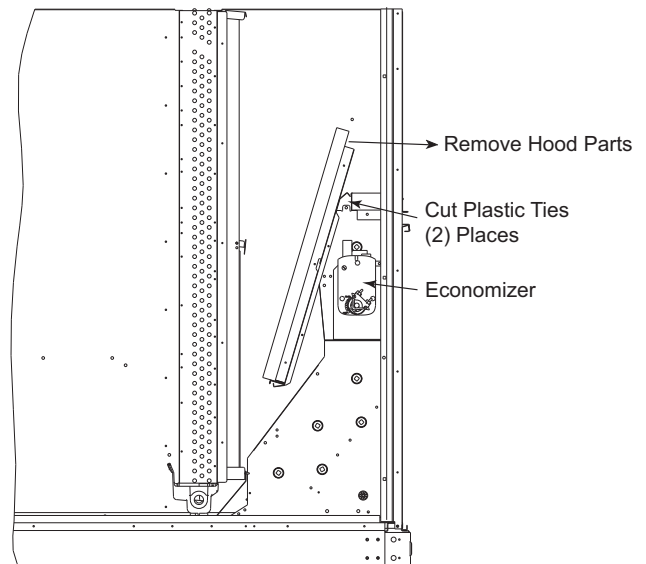

Fig. 11 — Economizer Hood Package Location

TWO POSITION DAMPER HOOD REMOVAL AND SETUP — FACTORY OPTION

1. The hood is shipped in knock-down form and assembled to a metal support tray using plastic stretch wrap. Located in the return air compartment, the assembly's metal tray is attached to the basepan and also attached to the damper using two plastic tie-wraps.
2. To gain access to the hood, remove the filter access panel. (See Fig. 10.)
3. Locate the (2) screws holding the metal tray to the basepan and remove. In order to remove the screws, it may be necessary to remove the panel underneath the two-position damper. Remove the two screws. Locate and cut the (2) plastic tie-wraps securing the assembly to the damper. (See Fig. 12.) Be careful to not damage any wiring or cut tie-wraps securing any wiring.
4. Carefully lift the hood assembly (with metal tray) through the filter access opening and assemble per the steps outlined in Economizer Hood and Two-Position Hood on page 12.

- If removed, reattach the panel under the damper.

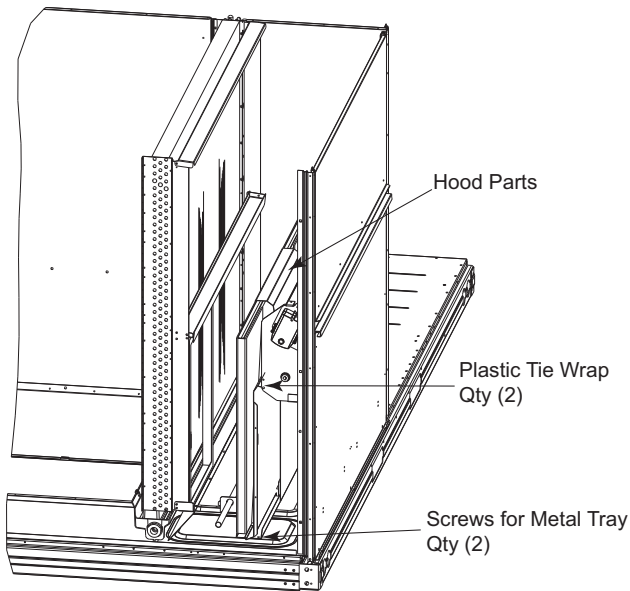

Fig. 12 — Two-Position Damper Hood Package Location

ECONOMIZER HOOD AND TWO-POSITION HOOD

NOTE: If the power exhaust accessory is to be installed on the unit, the hood shipped with the unit will not be used and must be discarded. Save the aluminum filter for use in the power exhaust hood assembly.

- The indoor coil access panel will be used as the top of the hood. If the panel is still attached to the unit, remove the screws along the sides and bottom of the panel. See Fig. 13.
- Swing out indoor coil access panel and insert the hood sides under the panel (hood top). *Be careful not to lift the panel too far as it might fall out.* Use the screws provided to attach the hood sides to the hood top. Use screws provided to attach the hood sides to the unit. See Fig. 14.
- Remove the shipping tape holding the economizer barometric relief damper in place.
- Insert the hood divider between the hood sides. See Fig. 14 and 15. Secure hood divider with 3 screws on each hood side. The hood divider is also used as the bottom filter rack for the aluminum filter.
- Attach the post that separates the filters with the screws provided.
- Open the filter clips which are located underneath the hood top. Insert the aluminum filters into the bottom filter rack (hood divider). Push the filter into position past the open filter clips. Close the filter clips to lock the filters into place. See Fig. 15.
- Install the two rain deflectors on the edge of the hood top as shown in Fig. 13.
- Caulk the ends of the joint between the unit top panel and the hood top as shown in Fig. 13.
- Replace the filter access panel.

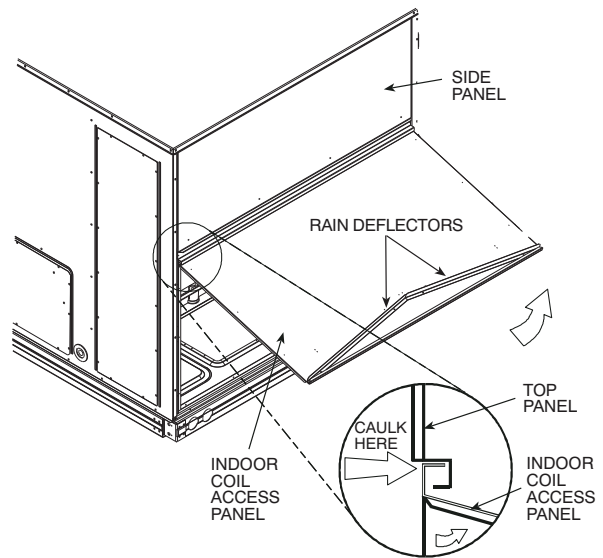

Fig. 13 — Indoor Coil Access Panel Relocation

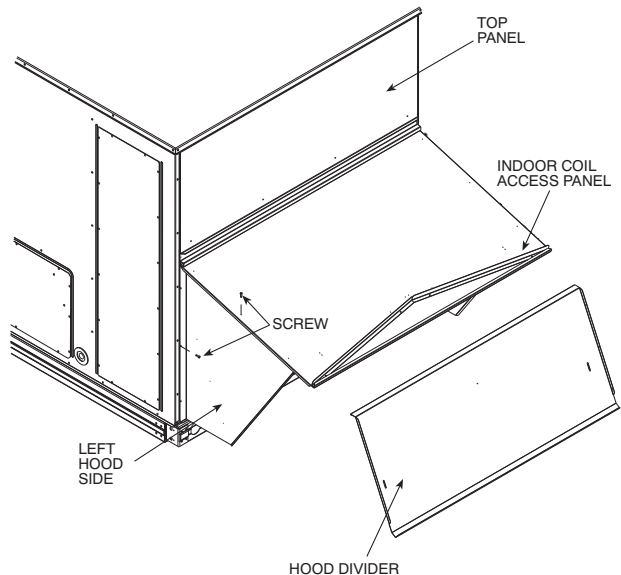

Fig. 14 — Economizer Hood Construction

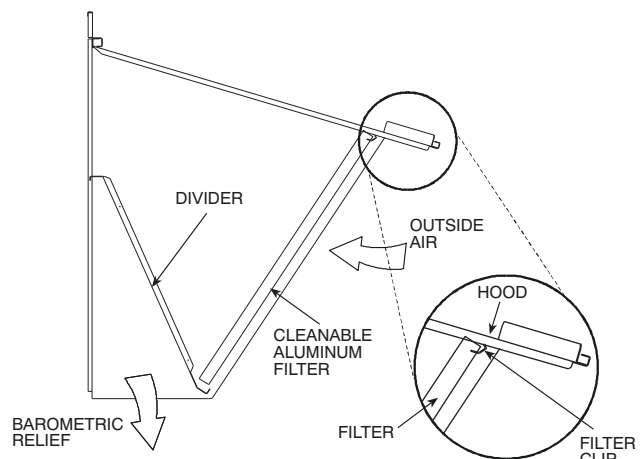

Fig. 15 — Economizer Filter Installation

Step 9 — Install External Condensate Trap and Line — The unit has one 3/4-in. condensate drain connection on the end of the condensate pan and an alternate connection on the bottom. See Fig. 16. Unit airflow configuration does not determine which drain connection to use. Either drain connection can be used with vertical or horizontal applications.

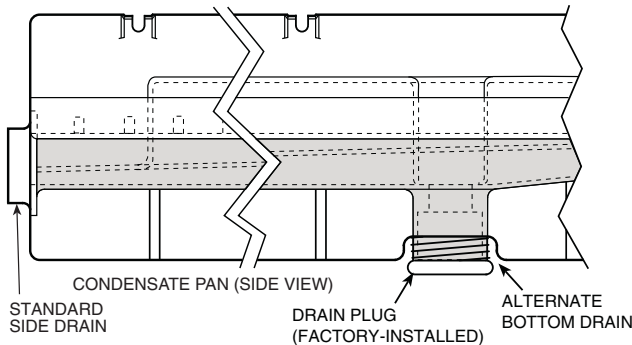

Fig. 16 — Condensate Drain Pan (Side View)

When using the standard side drain connection, ensure the red plug in the alternate bottom connection is tight. Do this before setting the unit in place. The red drain pan can be tightened with a 1/2-in. square socket drive extension.

To use the alternate bottom drain connection, remove the red drain plug from the bottom connection (use a 1/2-in. square socket drive extension) and install it in the side drain connection.

The piping for the condensate drain and external trap can be completed after the unit is in place. See Fig. 17.

All units must have an external trap for condensate drainage. Install a trap at least 4-in. (102 mm) deep and protect against freeze-up. If drain line is installed downstream from the external trap, pitch the line away from the unit at 1-in. per 10 ft (25 mm in 3 m) of run. Do not use a pipe size smaller than the unit connection (3/4-in.).

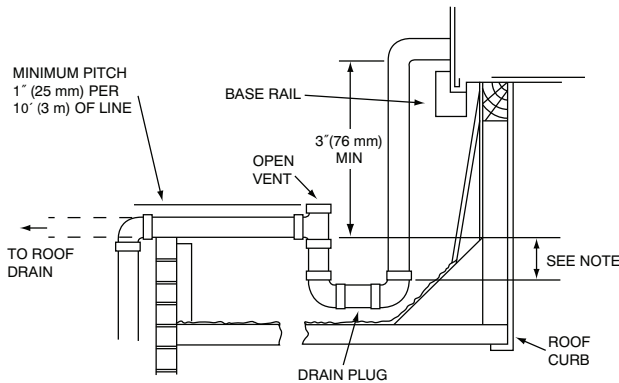

NOTE: Trap should be deep enough to offset maximum unit static difference. A 4 in. (102 mm) trap is recommended.

Fig. 17 — Condensate Drain Piping Details

Step 10 — Make Electrical Connections

⚠ WARNING

ELECTRICAL SHOCK HAZARD

Failure to follow this warning could result in personal injury or death.

Unit cabinet must have an uninterrupted, unbroken electrical ground to minimize the possibility of personal injury if an electrical fault should occur. This ground may consist of electrical wire connected to unit ground lug in control compartment, or conduit approved for electrical ground when installed in accordance with NEC (National Electrical Code); ANSI/NFPA 70, latest edition (in Canada, Canadian Electrical Code CSA [Canadian Standards Association] C22.1), and local electrical codes.

NOTE: Field-supplied wiring shall conform with the limitations of minimum 63°F (3°C) rise.

FIELD POWER SUPPLY — For those units without through-the-curb power, conduit must be used to route the main power from the condenser end, via the power entry in the corner post of the unit (see Fig. 18-20) to either the factory option disconnect or the bottom of the control box. 1-in. conduit is provided wrapped around compressor. A second conduit is provided with factory installed powered convenience outlet. For those units that require conduit larger than 1-in., it must be field supplied. Figures 18-20 show the wire routings.

If the field disconnect is larger than 100A, it must be attached to the unit using accessory CRDISBKT001A00 — disconnect switch bracket (see Fig. 21). Follow the instructions provided with this accessory. For smaller field disconnects, be sure to use 1/2-in. screws to mount the disconnect directly to the end panel (see Fig. 22). In either case, set the disconnect vertical location on the unit so that a 90 degree fitting can be used to connect the conduit to the disconnect.

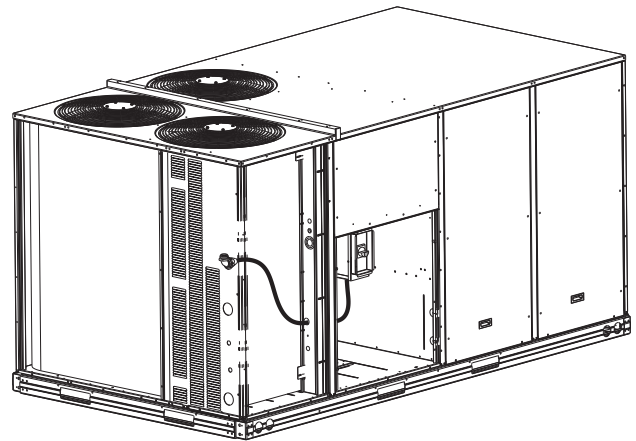

Fig. 18 — Conduit into Factory Option Non-Fused Disconnect or HACR

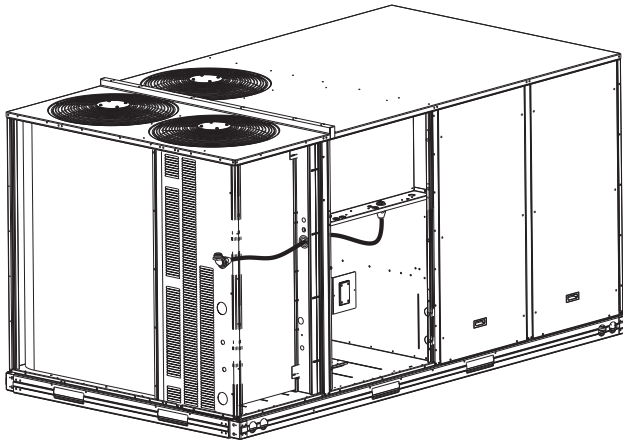

Fig. 19 — Conduit into Control Box

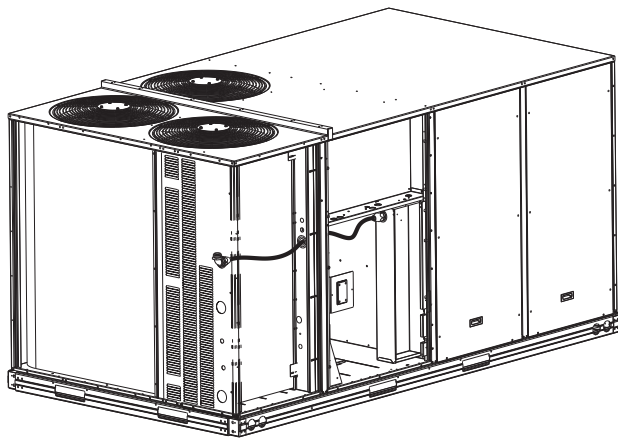

Fig. 20 — Conduit into Single Point Box

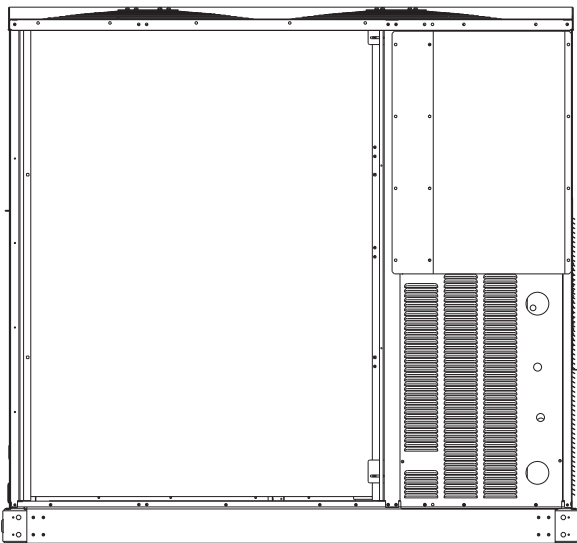

Fig. 21 — Mounting Position for Field Disconnects (over 100A)

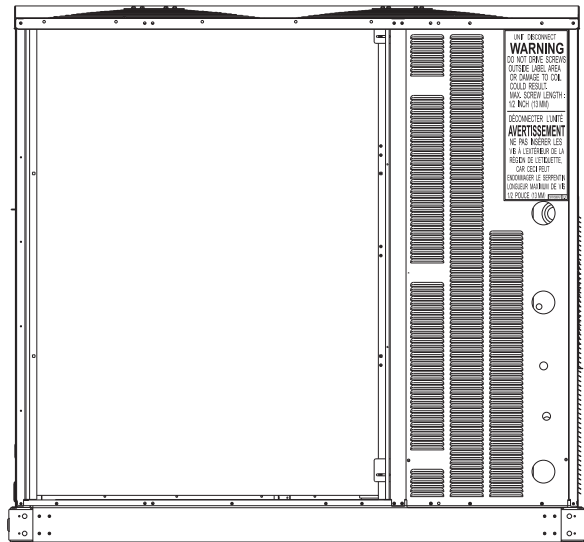

Fig. 22 — Mounting Position for Field Disconnects (up to 100A)

Field power wires are connected to the unit at line-side pressure lugs at the main terminal block (TB1) or at factory-installed option non-fused disconnect switch or HACR, or field or factory-installed Single Point box for electric heat. Refer to Table 2 for maximum wire size at connection lugs. Use copper wire only. See Fig. 23.

Table 2 — Connection Lug Min/Max Wire Sizes

	MINIMUM	MAXIMUM
TB1 in unit control box	#14	#1
Terminal/Fuse block in Single Point Box for Electric Heat	#8	3/0
80A Disconnect Option	#14	#4
100A Disconnect Option	#8	1/0
200A Disconnect Option	#4	300 kcmil
25A HACR Option	#14	1/0
30A HACR Option	#14	1/0
35A HACR Option	#14	1/0
40A HACR Option	#14	1/0
50A HACR Option	#14	1/0
60A HACR Option	#14	1/0
70A HACR Option	#14	1/0
80A HACR Option	#14	1/0
90A HACR Option	#14	1/0
100A HACR Option	#14	1/0
110A HACR Option	#4	300 kcmil
125A HACR Option	#4	300 kcmil
150A HACR Option	#4	300 kcmil
175A HACR Option	#4	300 kcmil
200A HACR Option	#4	300 kcmil

NOTE: TEST LEADS — Unit may be equipped with short leads (pigtails) on the field line connection points off the optional non-fused disconnect switch or HACR. These leads are for factory run-test purposes only; remove and discard before connecting field power wires to unit connection points. Make field power connections directly to line connection pressure lugs only.

Units Without Single Point Box, Disconnect or HACR Option

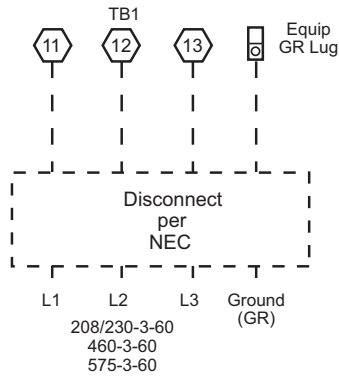

Units With Disconnect or HACR Option

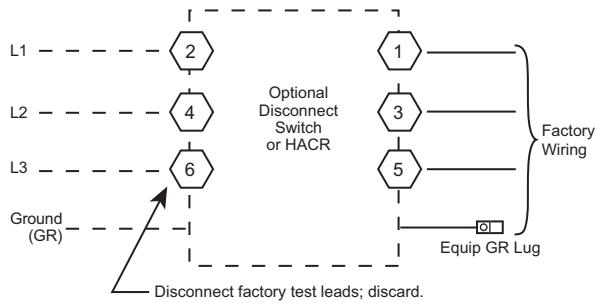

Units With Electric Heat Option with Single Point Box and Without Disconnect or HACR Option

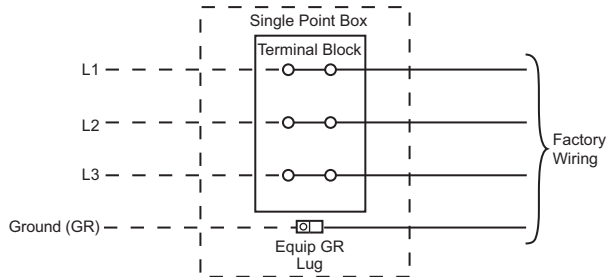

— OR —

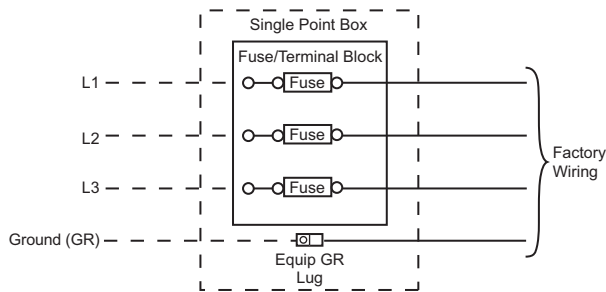

Fig. 23 — Power Wiring Connections

WARNING

FIRE HAZARD

Failure to follow this warning could result in personal injury, death, or property damage intermittent operation or performance satisfaction.

Do not connect aluminum wire between disconnect switch and air conditioning unit. Use only copper wire. (See Fig. 24.)

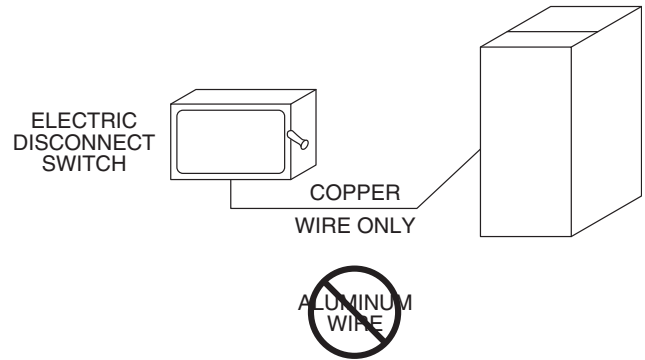

Fig. 24 — Disconnect Switch and Unit

ALL UNITS — All field wiring must comply with NEC and all local requirements.

Size wire based on MCA (Minimum Circuit Amps) on the unit informative plate. See Fig. 23 and the unit label diagram for power wiring connections to the unit power terminal blocks and equipment ground. Refer to Table 2 for maximum wire size at connection lugs.

Provide a ground-fault and short-circuit over-current protection device (fuse or breaker) per NEC Article 440 (or local codes). Refer to unit informative data plate for MOCP (Maximum Over-current Protection) device size.

NOTE: Units ordered with factory installed HACR do not need an additional ground-fault and short-circuit over-current protection device unless local codes require.

Voltage to compressor terminals during operation must be within voltage range indicated on unit nameplate. On 3-phase units, voltages between phases must be balanced within 2% and the current within 10%. Use the following formula to determine the percent of voltage imbalance.

% Voltage imbalance

$$= 100 \times \frac{\text{max voltage deviation from average voltage}}{\text{average voltage}}$$

Example: Supply voltage is 230-3-60.

- AB = 224 v
- BC = 231 v
- AC = 226 v

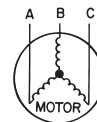

$$\begin{aligned} \text{Average Voltage} &= \frac{224 + 231 + 226}{3} \\ &= \frac{681}{3} \\ &= 227 \end{aligned}$$

Determine maximum deviation from average voltage.

- (AB) 227 - 224 = 3 v
- (BC) 231 - 227 = 4 v
- (AC) 227 - 226 = 1 v

Maximum deviation is 4 v.

Determine percent of voltage imbalance.

$$\begin{aligned} \% \text{ Voltage Imbalance} &= 100 \times \frac{4}{226} \\ &= 1.76\% \end{aligned}$$

This amount of phase imbalance is satisfactory as it is below the maximum allowable 2%.

IMPORTANT: If the supply voltage phase imbalance is more than 2%, contact your local electric utility company immediately.

All units except 208/230-v units are factory wired for the voltage shown on the nameplate. *If the 208/230-v unit is to be connected to a 208-v power supply, the control transformer must be rewired by moving the black wire with the 1/4-in. female spade connector from the 230-v connection and moving it to the 200-v 1/4-in. male terminal on the primary side of the transformer.* Refer to unit label diagram for additional information.

CAUTION

UNIT DAMAGE HAZARD

Failure to follow this caution may result in equipment damage.

Operation on improper line voltage or excessive phase imbalance constitutes abuse and may cause damage to electrical components. Such operation would invalidate any applicable Carrier warranty.

NOTE: Check all factory and field electrical connections for tightness.

UNITS WITHOUT FACTORY-INSTALLED NON-FUSED DISCONNECT OR HACR — When installing units, provide a disconnect switch of adequate size per NEC (National Electrical Code). Disconnect sizing data is provided on the unit informative plate. Locate on unit cabinet or within sight of the unit per national or local codes. Do not cover unit informative plate if mounting the disconnect on the unit cabinet.

UNITS WITH FACTORY-INSTALLED NON-FUSED DISCONNECT OR HACR — The factory-installed option non-fused disconnect switch (NFD) is located in a weather-proof enclosure located under the main control box. The manual switch handle is shipped in the disconnect or HACR enclosure. Assemble the shaft and handle to the switch or HACR at this point. Discard the factory test leads (see Fig. 23). The factory disconnect is a 200A disconnect on 230-3-60 units and a 100A disconnect on 460-3-60 and 575-3-60 units. On units with factory installed non-fused disconnect, without factory installed electric heat, the factory supplied load side wires may be of insufficient size for accessory electric heat applications. If so, remove the load side factory wiring. Re-size wires per unit nameplate data provided with accessory electric heat.

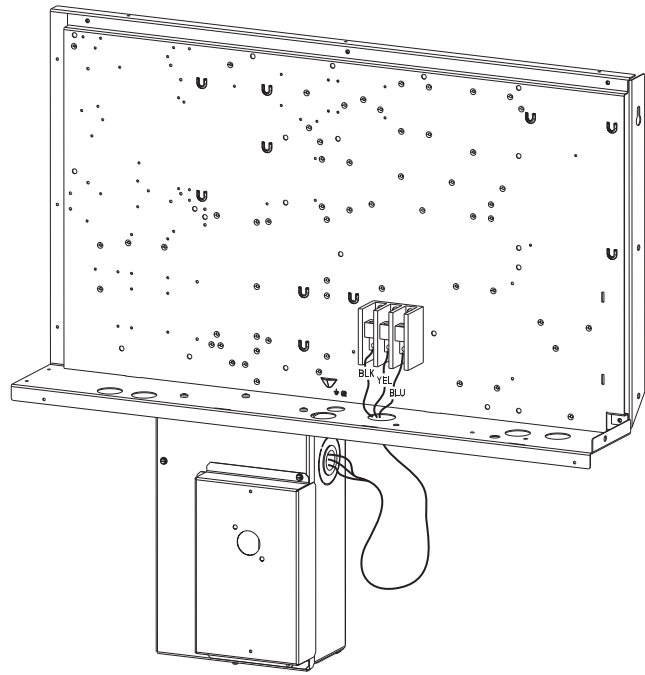

Fig. 25 — Location of Non-Fused Disconnect Enclosure

To field install the NFD shaft and handle:

1. Remove the unit front panel (see Fig. 2).
2. Remove (3) hex screws on the NFD enclosure - (2) on the face of the cover and (1) on the bottom.
3. Remove the front cover of the NFD enclosure.
4. Make sure the NFD shipped from the factory is at OFF position (the arrow on the black handle knob is at OFF).
5. Insert the shaft with the cross pin on the top of the shaft in the horizontal position.
6. Measure the tip of the shaft to the top surface of the pointer to be 3.75 to 3.88 in. (95 to 99 mm) for 80A and 100A NFD and 3.43 to 3.56 in. (87 to 90 mm) for 200A NFD.
7. Tighten the locking screw to secure the shaft to the NFD.
8. Turn the handle to the OFF position with red arrow pointing at OFF.
9. Install the handle on to the painted cover horizontally with the red arrow pointing to the left.
10. Secure the handle to the painted cover with (2) screws and lock washers supplied.
11. Engaging the shaft into the handle socket, re-install (3) hex screws on the NFD enclosure.
12. Re-install the unit front panel.

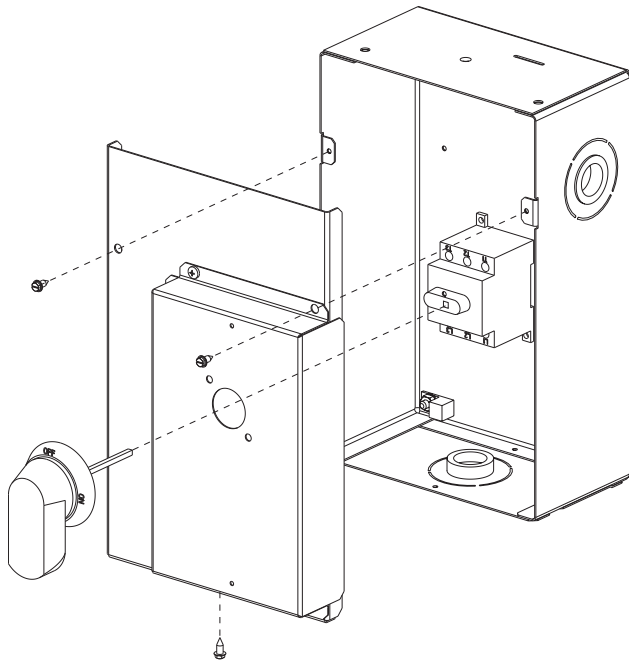

Fig. 26 — Handle and Shaft Assembly for NFD

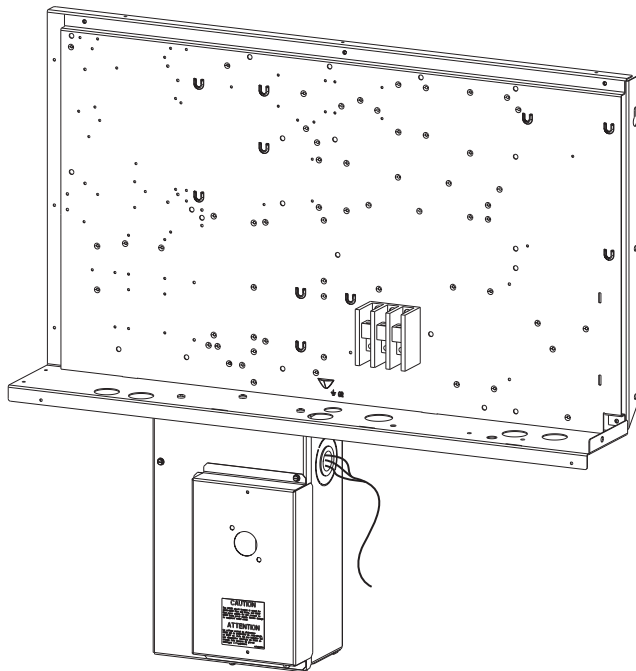

Fig. 27 — Location of HACR Enclosure

To field install the HACR shaft and handle:

1. Remove the unit front panel (see Fig. 2).
2. Remove (3) hex screws on the HACR enclosure - (2) on the face of the cover and (1) on bottom.
3. Remove the front cover of the HACR enclosure.
4. Make sure the HACR shipped from the factory is at OFF position (the white arrow pointing at OFF).
5. Insert the shaft all the way with the cross pin on the top of the shaft in the horizontal position.

6. Tighten the locking screw to secure the shaft to the HACR.
7. Turn the handle to the OFF position with red arrow pointing at OFF.
8. Install the handle on to the painted cover horizontally with the red arrow pointing to the left.
9. Secure the handle to the painted cover with (2) screws and lock washers supplied.
10. Engaging the shaft into the handle socket, re-install (3) hex screws on the HACR enclosure.
11. Re-install the unit front panel.

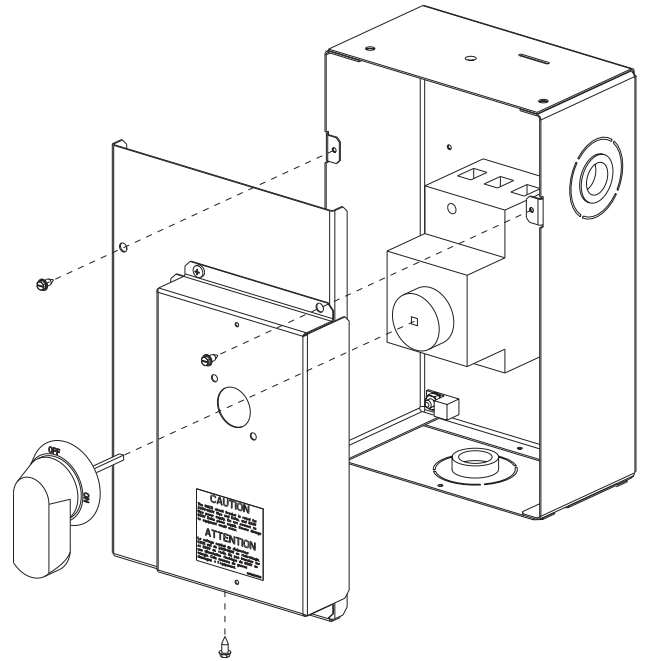

Fig. 28 — Handle and Shaft Assembly for HACR CONVENIENCE OUTLETS

⚠ WARNING

ELECTRICAL OPERATION HAZARD

Failure to follow this warning could result in personal injury or death.

Units with convenience outlet circuits may use multiple disconnects. Check convenience outlet for power status before opening unit for service. Locate its disconnect switch, if appropriate, and open it. Lock-out and tag-out this switch, if necessary.

Two types of convenience outlets are offered on the 50HC**14 models: non-powered and unit-powered. Both types provide a 125-volt GFCI (ground-fault circuit-interrupter) duplex receptacle rated at 15-A behind a hinged waterproof access cover, located on the panel beneath the control box. See Fig. 29.

Non-powered type: This type requires the field installation of a general-purpose 125-volt 15-A circuit powered from a source elsewhere in the building. Observe national and local codes when selecting wire size and conduit requirements, fuse or breaker requirements and disconnect switch size and location. Route 125-v power supply conductors into the bottom of the utility box containing the duplex receptacle.

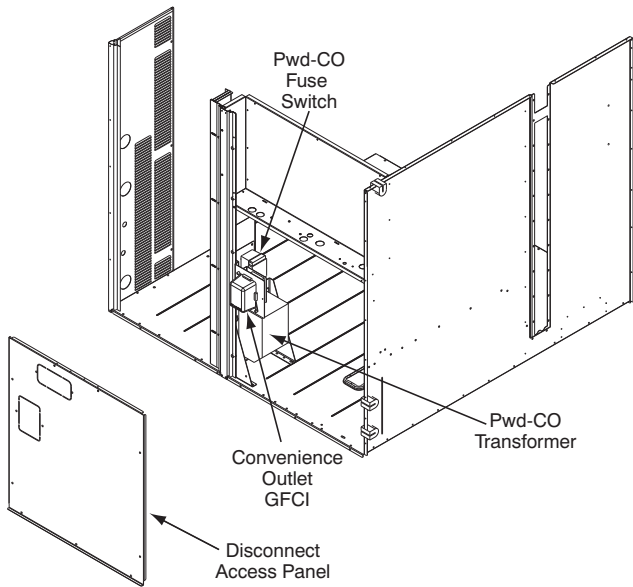

Fig. 29 — Convenience Outlet Location

Unit-powered type: A unit-mounted transformer is factory-installed to stepdown the main power suppl voltage to the unit to 115-v at the duplex receptacle. This option also includes a manual switch with fuse, located in a utility box and mounted on a bracket behind the convenience outlet; access is through the unit's control box access panel. See Fig. 29.

The primary leads to the convenience outlet transformer are not factory-connected. Selection of primary power source is a customer-option. If local codes permit, the transformer primary leads can be connected at the line-side terminals on the unit-mounted non-fused disconnect; this will provide service power to the unit when the unit disconnect switch is open. Other connection methods will result in the convenience outlet circuit being de-energized when the unit disconnect switch is open. See Fig. 31. On a unit without a unit-mounted disconnect, connect the source leads to the main terminal block (TB1).

If the convenience outlet transformer is connected to the line side of a field disconnect, the conduit provided with the unit must be used to protect the wire as they are routed from the transformer to the field disconnect. The end of the conduit with the straight connector attaches to the field disconnect. The other end does not need to connect to the transformer; however, the conduit must be routed so that all wiring is either in the conduit or behind the access panel.

If the convenience outlet transformer is connected to the line side of the factory disconnect option, route the wires through the web bushing located on the bottom of the disconnect box. For the load side wiring to the factory option disconnect, route the wires through the hole on the right side of the disconnect. Be sure to create a drip loop at least 6-in. long.

Test the GFCI receptacle by pressing the TEST button on the face of the receptacle to trip and open the receptacle. Check for proper grounding wires and power line phasing if the GFCI receptacle does not trip as required. Press the RESET button to clear the tripped condition.

NOTICE/AVIS

Convenience Outlet Utilization
 Maximum Intermittent Use 15 - Amps
 Maximum Continuous Use 8 - Amps
 Observe a 50% limit on the circuit
 Loading above 8 - Amps

Utilisation de la prise utilitaire
 Usage intermittent maximum 15 - Amps
 Usage continu maximum 8 - Amps
 Observez une limite de 50% sur le circuit
 Chargement au-dessus de 8 - Amps

50HE501288 2.0

Fig. 30 — Convenience Utilization Notice

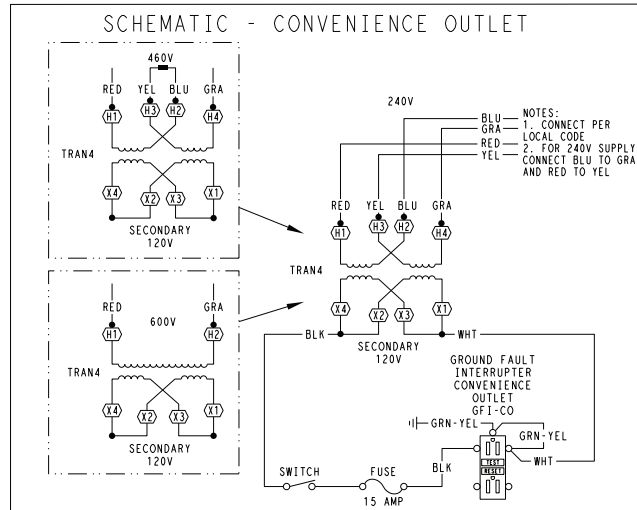

UNIT VOLTAGE	CONNECT AS	PRIMARY CONNECTIONS	TRANSFORMER TERMINALS
208,230	240	L1: RED + YEL L2: BLU + GRA	H1 + H3 H2 + H4
460	480	L1: RED Splice BLU + YEL L2: GRA	H1 H2 + H3 H4
575	600	L1: RED L2: GRA	H1 H2

Fig. 31 — Unit Powered Convenience Outlet Wiring

Fuse on power type: The factory fuse is a Bussman “Fusetron” T-15, non-renewable screw-in (Edison base) type plug fuse.

⚠ WARNING

ELECTRICAL OPERATION HAZARD

Failure to follow this warning could result in personal injury or death.

Using unit-mounted convenience outlets: Units with unit-mounted convenience outlet circuits will often require that two disconnects be opened to de-energize all power to the unit. Treat all units as electrically energized until the convenience outlet power is also checked and de-energization is confirmed. Observe National Electrical Code Article 210, Branch Circuits, for use of convenience outlets.

Installing Weatherproof Cover: A weatherproof while-in-use cover for the factory-installed convenience outlets is now required by UL standards. This cover cannot be factory-mount-

ed due its depth; it must be installed at unit installation. For shipment, the convenience outlet is covered with a blank cover plate.

The weatherproof cover kit is shipped in the unit's control box. The kit includes the hinged cover, a backing plate and gasket.

DISCONNECT ALL POWER TO UNIT AND CONVENIENCE OUTLET. LOCK-OUT AND TAG-OUT ALL POWER.

Remove the blank cover plate at the convenience outlet; discard the blank cover.

Loosen the two screws at the GFCI duplex outlet, until approximately 1/2-in. (13 mm) under screw heads are exposed. Press the gasket over the screw heads. Slip the backing plate over the screw heads at the keyhole slots and align with the gasket; tighten the two screws until snug (do not over-tighten).

Mount the weatherproof cover to the backing plate as shown in Fig. 32. Remove two slot fillers in the bottom of the cover to permit service tool cords to exit the cover. Check for full closing and latching.

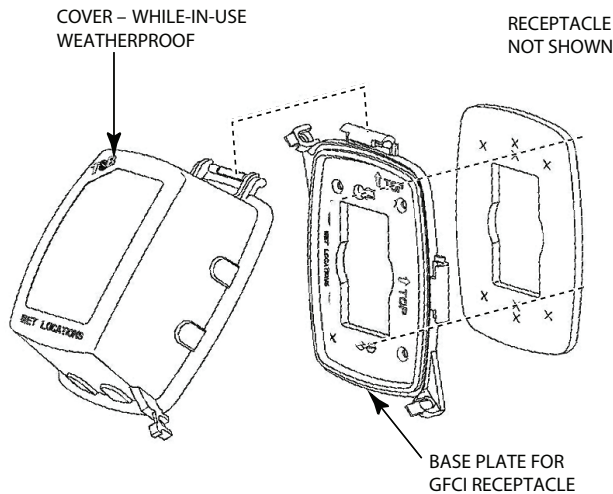

Fig. 32 — Weatherproof Cover Installation

HACR — The amp rating of the HACR factory-installed option is based on the size, voltage, indoor motor and other electrical options of the unit as shipped from the factory. If field-installed accessories are added or changed in the field (i.e., power exhaust), the HACR may no longer be of the proper amp rating and therefore will need to be removed from the unit. See unit nameplate and label on factory-installed HACR for the amp rating of the HACR that was shipped with the unit from the factory. See unit nameplates for the proper fuse, HACR or maximum over-current protection device required on the unit with field-installed accessories.

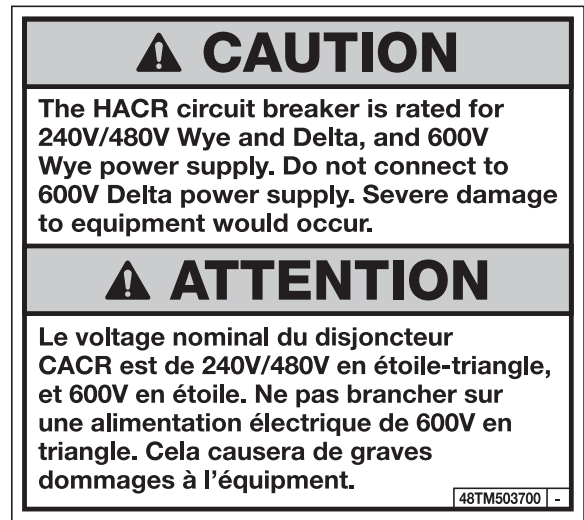

Fig. 33 — HACR Caution Label

FACTORY OPTION THRU-BASE CONNECTIONS — This service connection kit consists of a 1/2-in. electrical bulkhead connector and a 1 1/2-in. electrical bulkhead connector, connected to an “L” bracket covering the embossed (raised) section of the unit basepan in the condenser section. See Fig. 34. The 1/2-in. bulkhead connector enables the low-voltage control wires to pass through the basepan. The 1 1/2-in. electrical bulkhead connector allows the high-voltage power wires to pass through the basepan.

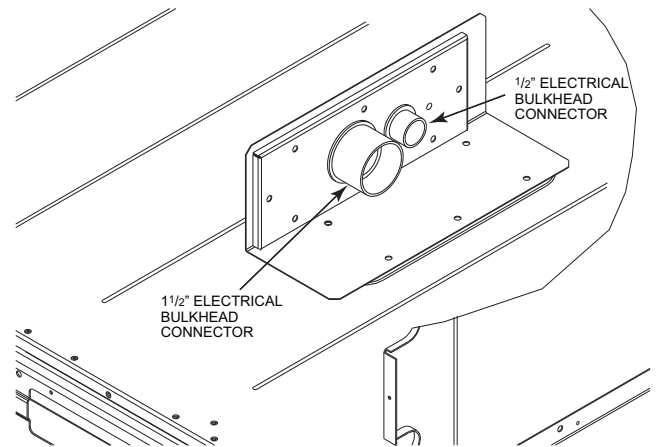

Fig. 34 — Thru-the Base Option, Shipping Position

1. Remove the “L” bracket assembly from the unit.
2. Remove connector plate assembly from the “L” bracket and discard the “L” bracket, but retain the washer head screws and the gasket (located between the “L” bracket and the connector plate assembly).

NOTE: Take care not to damage the gasket, as it is reused in the following step.

3. Place the gasket over the embossed area in the basepan, aligning the holes in the gasket to the holes in the basepan. See Fig. 35.
4. Install the connector plate assembly to the basepan using 8 of the washer head screws.

NOTE: If electrical connections are not going to occur at this time, tape or otherwise cover the fittings so that moisture does not get into the building or conduit in the interim.

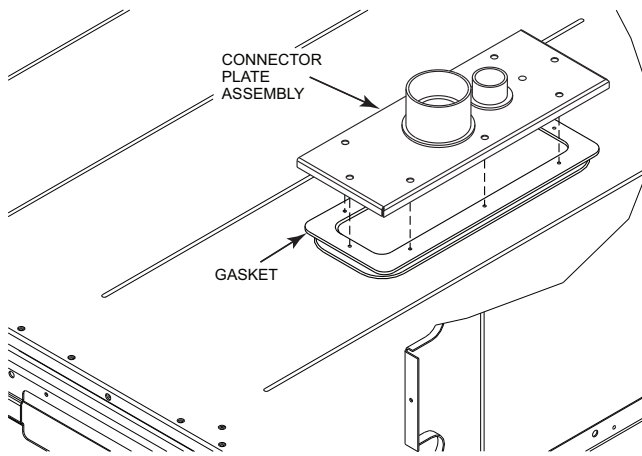

Fig. 35 — Installing Thru-the Base Option

Check tightness of connector lock nuts before connecting electrical conduits.

Field-supplied and field-installed liquid-tight conduit connectors and conduit may be attached to the connectors on the basepan. Pull correctly rated high voltage and low voltage through appropriate conduits. Connect the power conduit to the internal disconnect (if unit is so equipped) or to the external disconnect (through unit side panel). Remove one of the two knockouts located on the bottom left side of the unit control box. Use this hole for the control conduit.

UNITS WITHOUT THRU-BASE CONNECTIONS

1. Install power wiring conduit through side panel openings. Install conduit between disconnect and control box.
2. Install power lines to terminal connections as shown in Fig. 23.

FIELD CONTROL WIRING — The 50HC**14 unit requires an external temperature control device. This device can be a thermostat (field-supplied) or a PremierLink™ controller (available as factory-installed option or as field-installed accessory, for use on a Carrier Comfort Network® or as a stand alone control) or the RTU Open Controller for Building Management Systems using non-CCN protocols (RTU Open controller is available as a factory-installed option only).

THERMOSTAT — Select a Carrier-approved accessory thermostat. When electric heat is installed in the 50HC unit, the thermostat must be capable of energizing the G terminal (to energize the Indoor Fan Contactor) whenever there is a space call for heat (energizing the W1 terminal). The accessory thermostats listed on the unit price pages can provide this signal but they are not configured to enable this signal as shipped.

Install the accessory thermostat according to installation instructions included with the accessory.

Locate the thermostat accessory on a solid wall in the conditioned space to sense average temperature in accordance with the thermostat installation instructions.

If the thermostat contains a logic circuit requiring 24-v power, use a thermostat cable or equivalent single leads of different colors with minimum of seven leads. If the thermostat does not require a 24-v source (no “C” connection required), use a thermostat cable or equivalent with minimum of six leads. Check the thermostat installation instructions for additional features which might require additional conductors in the cable.

For wire runs up to 50 ft (15 m), use no. 18 AWG (American Wire Gage) insulated wire (35°C minimum). For 50 to 75 ft (15 to 23 m), use no. 16 AWG insulated wire (35°C minimum). For over 75 ft (23 m), use no. 14 AWG insulated wire (35°C minimum). All wire sizes larger than no. 18 AWG

cannot be directly connected to the thermostat and will require a junction box and splice at the thermostat.

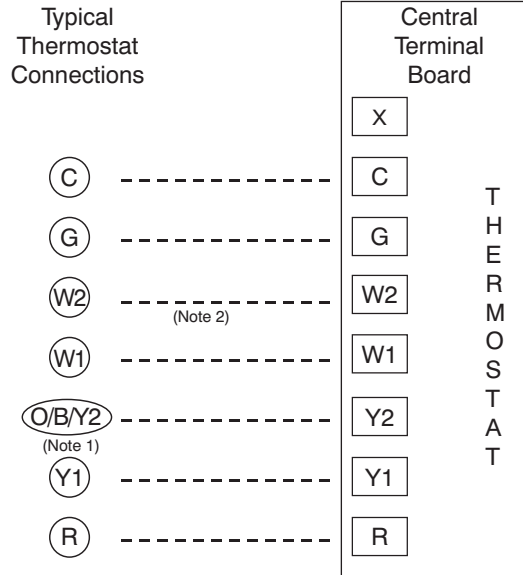

Note 1: Typical multi-function marking. Follow manufacturer's configuration instructions to select Y2. Do not configure for O output.

Note 2: W2 connection not required on units without electric heating.

--- Field Wiring

Fig. 36 — Typical Low-Voltage Control Connections

UNIT WITHOUT THRU-BASE CONNECTION KIT —

Pass the thermostat control wires through the bushing on the unit end panel. Route the wire through the snap-in wire tie and up to the web bushing near the control box. Route the wire through the bushing and into the bottom left side of the control box after removing one of the two knockouts in the corner of the box. Using a connector at the control box to protect the wire as it passes into the control box. Pull the wires over to the terminal strip at the upper left corner of the Central Terminal Board (CTB). Use the connector at the control box and the wire tie to take up any slack in the thermostat wire to ensure that it will not be damaged by contact with the condenser coil. See Fig. 37.

NOTE: If thru-the-bottom connections accessory is used, refer to the accessory installation instructions for information on routing power and control wiring.

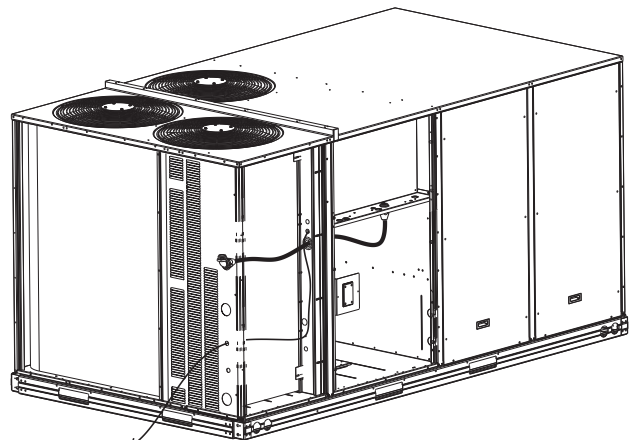

Fig. 37 — Thermostat Wire Routing

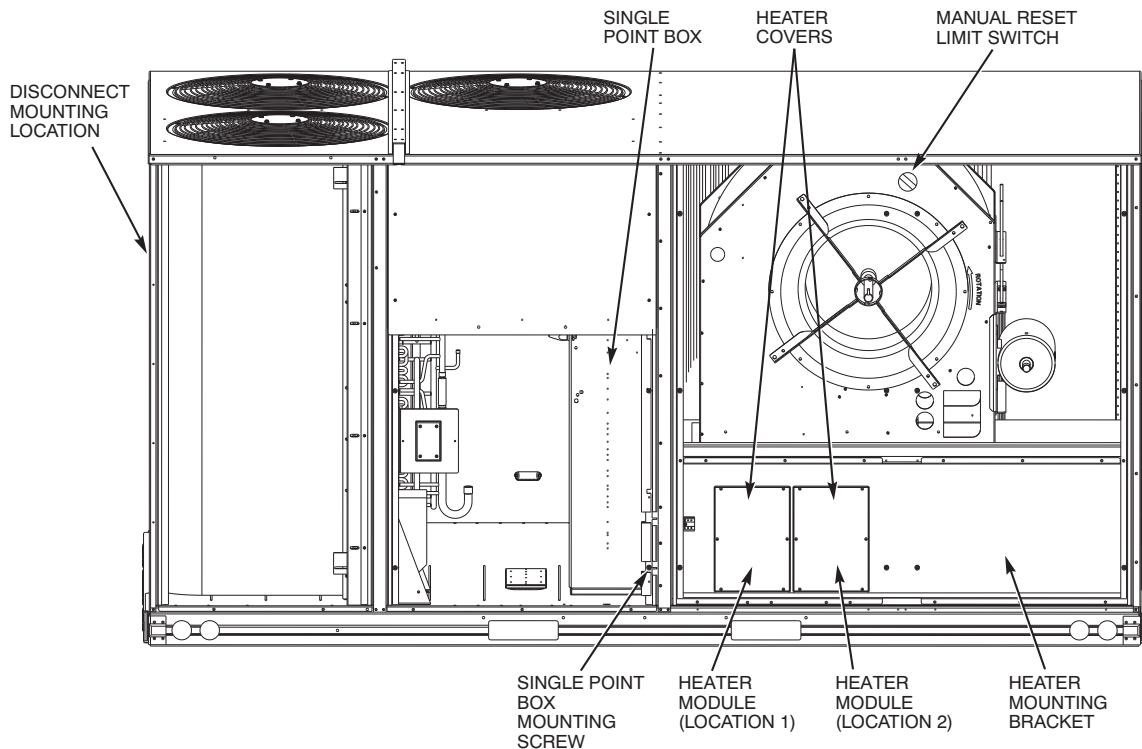

Fig. 38 — Typical Component Location

HEAT ANTICIPATOR SETTINGS — Set heat anticipator settings at 0.14 amp for the first stage and 0.14 amp for second-stage heating, when available.

Electric Heaters — The 50HC-*14 units may be equipped with factory or field-installed electric heaters. The heaters are modular in design, with heater frames holding open coil resistance wires strung through ceramic insulators, line-break limit switches and a control contactor. One or two heater modules may be used in a unit.

Heater modules are installed in the compartment below the indoor (supply) fan outlet. Access is through the indoor access panel. Heater modules slide into the compartment on tracks along the bottom of the heater opening. See Fig. 38.

CAUTION

UNIT DAMAGE HAZARD

Failure to follow this caution may result in equipment damage.

Not all available heater modules and single point boxes may be used in every unit. Use only those heater modules that are UL listed for use in a specific size unit. Refer to the label on the unit cabinet for the list of approved heaters and single point boxes.

Single Point Boxes — When heaters are installed, power wiring to both heaters and the rest of the unit is connected via the single point box accessory, which will be installed directly under the unit control box, just to the left of the partition separating the indoor section (with electric heaters) from the outdoor section. The single point box has a hinged access cover. See Fig. 39. The single point box also includes pigtailed to complete the wiring between the single point box and the unit's main control box terminals. The pigtailed will already be connected into the unit's main control box on units with factory installed electric heat. Refer to the accessory heater and Single

Point Box installation instructions for details on tap connections for field installed electric heat accessory.

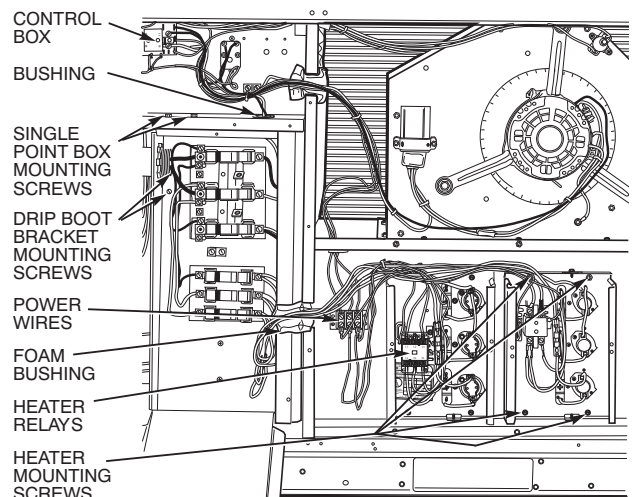

Fig. 39 — Typical Single Point Installation

HEATER AND SUPPLEMENTARY FUSES — When the unit MOCP device value exceeds 60-A, unit-mounted supplementary fuses are required for each heater circuit. These fuses are included in accessory Single Point Boxes, with power distribution and fuse blocks.

All fuses on 50HC-*14 units are 60-A. (Note that all heaters are qualified for use with a 60-A fuse, regardless of actual heater ampacity, so only 60-A fuses are necessary.)

HEATER LOW-VOLTAGE CONTROL CONNECTIONS — One or two heaters can be installed in the unit. Use the wiring procedure listed below for each heater as determined by the number of stages in the heater.

Single Stage Heaters: Single-stage heaters will have an orange and a brown control wire. Connect these to the orange and brown wires located on TB4. See Fig. 40.

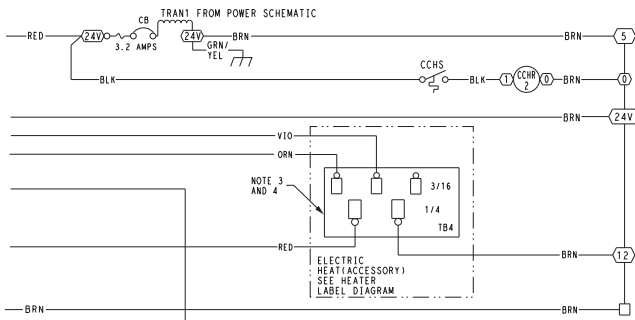

Fig. 40 — Single Stage Heaters: TB4 Wiring Connections

Two Stage Heaters: Two-stage heaters will have orange, violet, red and brown wires. The orange and the purple are the control wires and the red and brown wires feed the safety circuit. Connect both the orange and the purple wires to the orange wire locations of TB4. Connect the red and brown wires to red and brown wires on TB4. If more than one heater is installed, repeat the wiring procedure for the second heater. The 3 locations across the top of TB4 do allow a switch to be installed in series with some of the heaters in order to add additional heater control. See Fig. 41.

NOTE: The low voltage wiring will already be completed on units with factory installed electric heat.

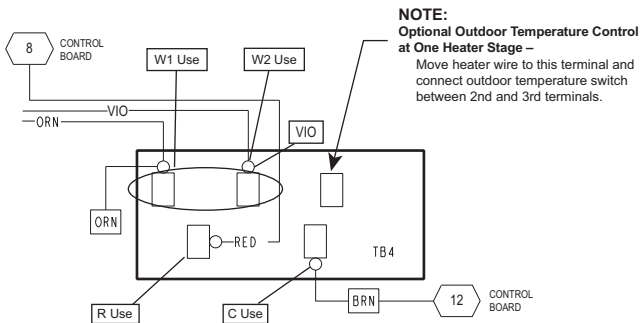

Fig. 41 — Two Stage Heaters: TB4 Wiring Connections

Humidi-MiZer® System Control Connections

HUMIDI-MIZER — SPACE RH CONTROLLER

NOTE: The Humidi-MiZer system is a factory-installed option.

The Humidi-MiZer dehumidification system requires a field-supplied and installed space relative humidity control device. This device may be a separate humidistat control (contact closes on rise in space RH above control setpoint) or a combination thermostat-humidistat control device such as Carrier's Edge® Pro Thermidistat with isolated contact set for dehumidification control. The humidistat is normally used in applications where a temperature control is already provided (units with PremierLink™ control).

To connect the Carrier humidistat (HL38MG029):

1. Route the humidistat 2-conductor cable (field-supplied) through the bushing in the unit's louvered end panel (see Fig. 37).
2. Route the cable through the snap-in wire tie and up to the web bushing near the control box.
3. Feed the cable through the bushing and into the bottom left side of the control box after removing one of the two knockouts in the corner of the box. Use a connector to protect the cable as it enters the control box.

4. Use the connector and the wire tie to reduce any slack in the humidistat cable to ensure that it will not be damaged by contact with the condenser coil (see Fig. 37).
5. Use wire nuts to connect humidistat cable to two PINK leads in the low-voltage wiring as shown in Fig. 44).

To connect the Thermidistat device (33CS2PPRH-01):

1. Route the Thermidistat multi-conductor thermostat cable (field-supplied) through the bushing in the unit's louvered end panel (see Fig. 37).
2. Route the cable through the snap-in wire tie and up to the web bushing near the control box
3. Feed the cable through the bushing and into the bottom left side of the control box after removing one of the two knockouts in the corner of the box. Use a connector to protect the cable as it enters the control box.
4. Use the connector and the wire tie to reduce any slack in the thermostat cable to ensure that it will not be damaged by contact with the condenser coil (see Fig. 37).
5. The Thermidistat has dry contacts at terminals D1 and D2 for dehumidification operation (see Fig. 45). The dry contacts must be wired between CTB terminal R and the PINK lead to the LTLO switch with field-supplied wire nuts. Refer to the installation instructions included with the Carrier Edge Pro Thermidistat device for more information.

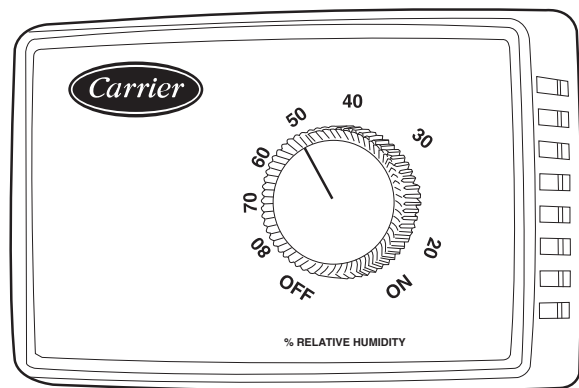

Fig. 42 — Accessory Field-Installed Humidistat



Fig. 43 — Edge Pro Thermidistat

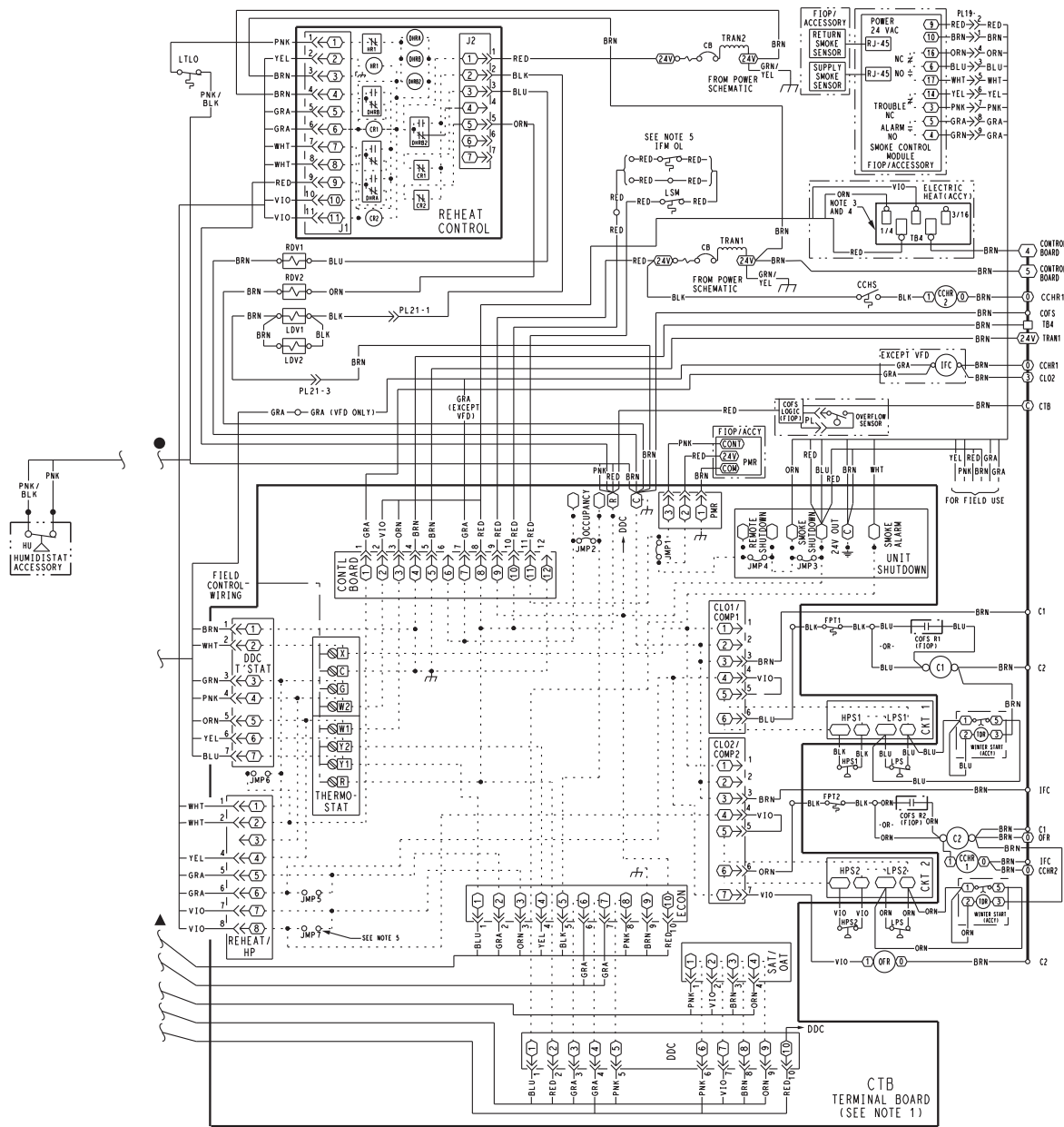
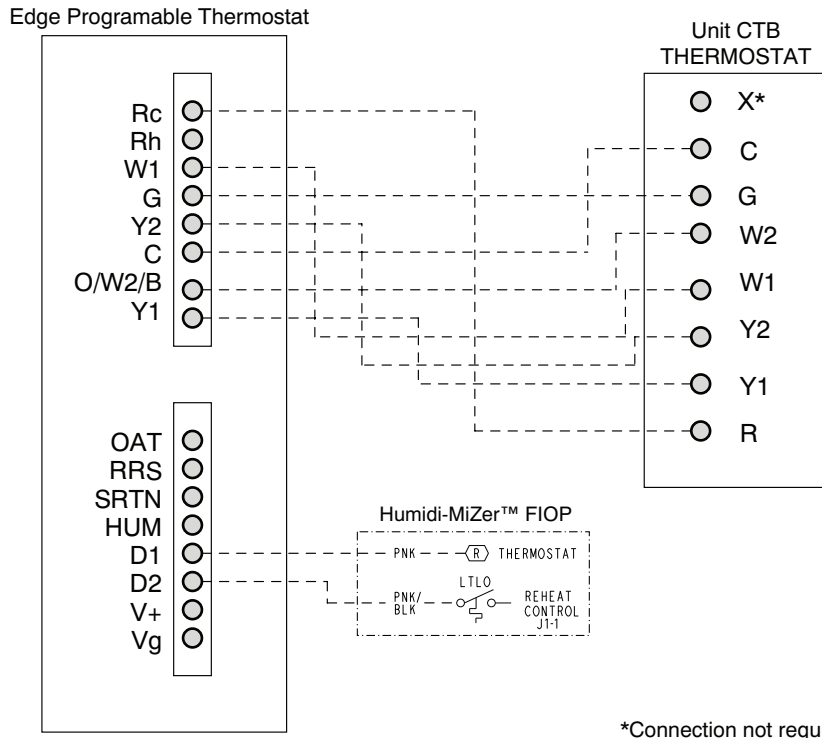

Fig. 44 — Typical Humidi-MiZer® Adaptive Dehumidification System Humidistat Wiring



*Connection not required.

Fig. 45 — Typical Rooftop Unit with Humidi-MiZer Adaptive Dehumidification System with Edge® Pro Thermostat Device

EconoMi\$er® X (Factory-Installed Option)

PRODUCT DESCRIPTION — The EconoMi\$er X system is an expandable economizer control system, which includes a W7220 economizer module (controller) with an LCD and keypad (See Fig. 46). The W7220 can be configured with optional sensors.



Fig. 46 — W7220 Economizer Module

The W7220 economizer module can be used as a stand-alone economizer module wired directly to a commercial set-back space thermostat and sensors to provide outside air dry-bulb economizer control.

The W7220 economizer module can be connected to optional sensors for single or differential enthalpy control. The W7220 economizer module provides power and communications for the sensors.

The W7220 economizer module automatically detects sensors by polling to determine which sensors are present. If a

sensor loses communications after it has been detected, the W7220 economizer controller indicates a device fail error on its LCD.

SYSTEM COMPONENTS — The EconoMi\$er X system includes an economizer module, 20k mixed air sensor, damper actuator, and either a 20k outdoor air temperature sensor or S-Bus enthalpy sensors.

Economizer Module — The module is the core of the EconoMi\$er X system. The module is mounted in the unit's control box, and includes the user interface for the system. The W7220 economizer module provides the basic inputs and outputs to provide simple economizer control. When used with the optional sensors, the economizer module provides more advanced economizer functionality.

S-Bus Enthalpy Control Sensors — The sensor is a combination temperature and humidity sensor which is powered by and communicates on the S-Bus. Up to three sensors may be configured with the W7220 economizer module.

CO₂ Sensor (optional) — The sensor can be added for Demand Controlled Ventilation (DCV).

SPECIFICATIONS

W7220 Economizer Module — The module is designed for use with 2 to 10 Vdc or bus communicating actuator. The module includes terminals for CO₂ sensor, Mixed Air sensor, and an Outdoor Dry Bulb sensor. Enthalpy and other options are available with bus sensors.

User Interface — Provides status for normal operation, setup parameters, checkout tests, and alarm and error conditions with a 2-line 16 character LCD display and four button keypad.

Electrical

Rated Voltage — 20 to 30 Vac RMS, 50/60 Hz

Transformer — 100 va maximum system input

Nominal Power Consumption (at 24 Vac, 60 Hz) — 11.5 VA without sensors or actuators

Relay Digital Output Rating at 30 Vac (maximum power from Class 2 input only) — 1.5A run:

3.5A inrush at 0.45PF (200,000 cycles) or

7.5A inrush at 0.45PF (100,000 cycles)

External Sensors Power Output — 21 Vdc ± 5% at 48mA

IMPORTANT: All inputs and outputs must be Class 2 wiring.

INPUTS

Sensors

NOTE: A Mixed Air (MA) analog sensor is required on all W7220 units; either an Outdoor Air (OA) sensor for dry bulb change over or an OA bus sensor for outdoor enthalpy change over is required in addition to the MA sensor. An additional Return Air (RA) bus sensor can be added to the system for differential enthalpy or dry bulb changeover. For differential dry bulb changeover a 20k ohm sensor is required in the OA and a bus sensor in the RA. DIP switch on RA bus sensor must be set in the RA position.

Dry Bulb Temperature (optional) and Mixed Air (required), 20k NTC

2-wire (18 to 22 AWG);

Temperature range -40 to 150 F (-40 to 65 C)

Temperature accuracy -0 F/+2 F

Temperature and Humidity, C7400S1000 (optional)

S-Bus; 2-wire (18 to 22 AWG)

Temperature: range -40 to 150 F (-40 to 65 C)

Temperature accuracy -0 F/+2 F

Humidity: range 0 to 100% RH with 5% accuracy.

NOTE: Up to three (3) S-Bus sensors may be connected to the W7220 economizer module. For outdoor air (OA), return air (RA) and discharge (supply) air (DA).

4 Binary Inputs — 1-wire 24 Vac + common GND (see page 27 for wiring details).

24 Vac power supply — 20 to 30 Vac 50/60Hz; 100 VA Class 2 transformer.

OUTPUTS

Actuator Signal: 2-10 Vdc; minimum actuator impedance is 2k ohm; bus two-wire output for bus communicating actuators.

Exhaust fan, Y1, Y2 and AUX1 O:

All Relay Outputs (at 30 Vac):

Running: 1.5A maximum

Inrush: 7.5A maximum

ENVIRONMENTAL

Operating Temperature:

-40 to 150 F (-40 to 65 C).

Exception of display operation down to -4 F with full recovery at -4 F from exposure to -40 F

Storage Temperature:

-40 to 150 F (-40 to 65 C)

Shipping Temperature:

-40 to 150 F (- 40 to 65 C)

Relative Humidity:

5% to 95% RH non-condensing

ECONOMIZER MODULE WIRING DETAILS — Use Fig. 47 and Tables 3 and 4 to locate the wiring terminals for the Economizer module.

NOTE: The four terminal blocks are removable. You can slide out each terminal block, wire it, and then slide it back into place.

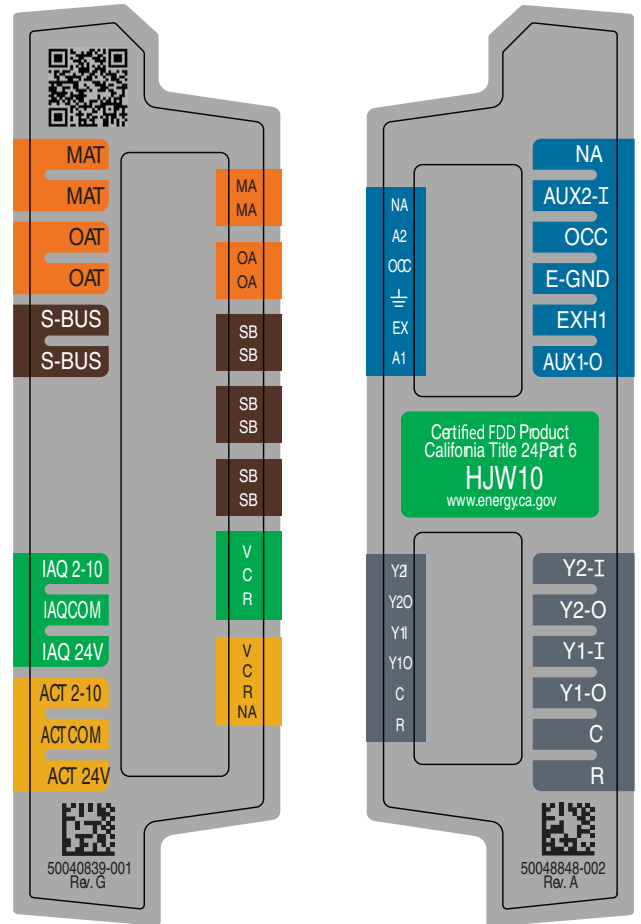

Fig. 47 — W7220 Wiring Terminals

Table 3 — Economizer Module - Left Hand Terminal Blocks

LABEL	TYPE	DESCRIPTION
Top Left Terminal Block		
MAT MAT	20k NTC and COM	Mixed Air Temperature Sensor (Polarity Insensitive Connection)
OAT OAT	20k NTC and COM	Outdoor Air Temperature Sensor (Polarity Insensitive Connection)
S-BUS S-BUS	S-BUS (Sylk Bus)	Enthalpy Control Sensor (Polarity Insensitive Connection)
Bottom Left Terminal Block		
IAQ 2-10	2-10 vdc	Air Quality Sensor Input (e.g. CO ₂ sensor)
IAQ COM	COM	Air Quality Sensor Common
IAQ 24V	24 vac	Air Quality Sensor 24 vac Source
ACT 2-10	2-10 vdc	Damper Actuator Output (2-10 vdc)
ACT COM	COM	Damper Actuator Output Common
ACT 24v	24 vac	Damper Actuator 24 vac Source

Table 4 — Economizer Module - Right Hand Terminal Blocks

LABEL	TYPE	DESCRIPTION
Top Right Terminal Blocks		
AUX2 I	24 vac IN	The first terminal is not used.
OCC	24 vac IN	Shut Down (SD) or HEAT (W) Conventional only and Heat Pump Changeover (O-B) in Heat Pump mode.
E-GND	E-GND	Occupied/Unoccupied Input
EXH1	24 vac OUT	Exhaust Fan 1 Output
AUX1 O	24 vac OUT	Programmable: Exhaust fan 2 output or ERV or System alarm output
Bottom Right Terminal Blocks		
Y2-I	24 vac IN	Y2 in - Cooling Stage 2 Input from space thermostat
Y2-O	24 vac OUT	Y2 out - Cooling Stage 2 Output to stage 2 mechanical cooling
Y1-I	24 vac IN	Y1 in - Cooling Stage 2 Input from space thermostat
Y1-O	24 vac OUT	Y1 out - Cooling Stage 2 Output to stage 2 mechanical cooling
C	COM	24 vac Common
R	24 vac	24 vac Power (hot)

S-BUS SENSOR WIRING — The labels on the sensors and controller are color coded for ease of installation. Orange labeled sensors can only be wired to orange terminals on the controller. Brown labeled sensors can only be wired to S-bus (brown) terminals. Use Fig. 48 and Table 5 to locate the wiring terminals for each S-Bus sensor.

Use Fig. 48 and Table 5 to locate the wiring terminals for each enthalpy control sensor.

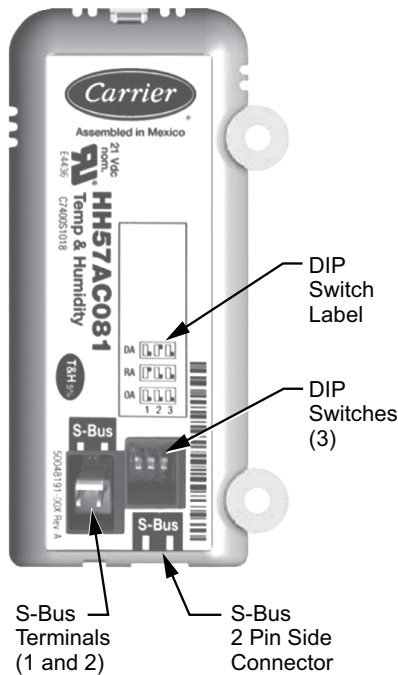

Fig. 48 — S-Bus Sensor DIP Switches

Table 5 — HH57AC081 Sensor Wiring Terminations

TERMINAL		TYPE	DESCRIPTION
NUMBER	LABEL		
1	S-BUS	S-BUS	S-BUS Communications (Enthalpy Control Sensor Bus)
2	S-BUS	S-BUS	S-BUS Communications (Enthalpy Control Sensor Bus)

Use Fig. 48 and Table 6 to set the DIP switches for the desired use of the sensor.

Table 6 — HH57AC081 Sensor DIP Switch

USE	DIP SWITCH POSITIONS FOR SWITCHES 1, 2, AND 3		
	1	2	3
DA	OFF	ON	OFF
RA	ON	OFF	OFF
OA	OFF	OFF	OFF

NOTE: When a S-Bus sensor is connected to an existing network, it will take 60 minutes for the network to recognize and auto-configure itself to use the new sensor.

During the 60 minute setup period, no alarms for sensor failures (except SAT) will be issued and no economizing function will be available.

CO₂ SENSOR WIRING — When using a CO₂ sensor the black and brown common wires are internally connected and only one is connected to “IAQ COM” on the W7220. Use the power from the W7220 to power the CO₂ sensor OR make sure the ground for the power supplies are common. See Fig. 49 for CO₂ sensor wiring.

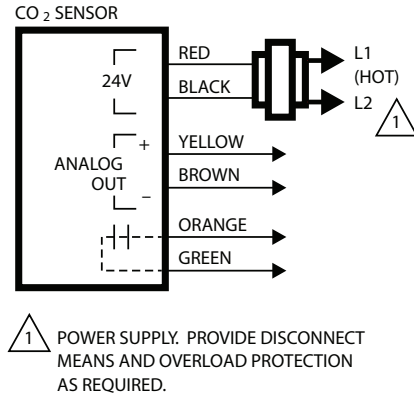

Fig. 49 — CO₂ Sensor Wiring

INTERFACE OVERVIEW — This section describes how to use the Economizer’s user interface for:

- Keypad and menu navigation
- Settings and parameter changes
- Menu structure and selection

USER INTERFACE — The user interface consists of a 2-line LCD display and a 4-button keypad on the front of the economizer controller.

KEYPAD — The four navigation buttons (see Fig. 50) are used to scroll through the menus and menu items, select menu items, and to change parameter and configuration settings.

To use the keypad when working with menus:

- Press the ▲ (Up arrow) button to move to the previous menu.
- Press the ▼ (Down arrow) button to move to the next menu.

- Press the (Enter) button to display the first item in the currently displayed menu.

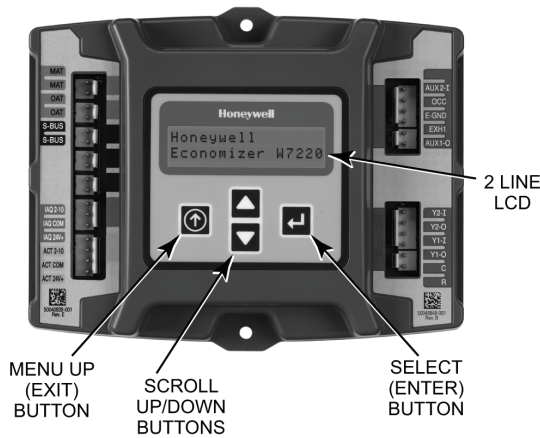



Fig. 50 — W7220 Controller Navigation Buttons

Press the  (Menu Up/Exit) button to exit a menu's item and return to the list of menus. To use the keypad when working with Setpoints, System and Advanced Settings, Checkout tests and Alarms:

1. Navigate to the desired menu.
2. Press the (Enter) button to display the first item in the currently displayed menu.
3. Use the ▲ and ▼ buttons to scroll to the desired parameter.
4. Press the (Enter) button to display the value of the currently displayed item.
5. Press the ▲ button to increase (change) the displayed parameter value.
6. Press the ▼ button to decrease (change) the displayed parameter value.

NOTE: When values are displayed, pressing and holding the or button causes the display to automatically increment.

7. Press the (Enter) button to accept the displayed value and store it in nonvolatile RAM.
8. "CHANGE STORED" displays.
9. Press the (Enter) button to return to the current menu parameter.

10. Press the (Menu Up/Exit) button to return to the previous menu.

MENU STRUCTURE — Table 7 illustrates the complete hierarchy of menus and parameters for the EconoMiSer® X system.

The Menu in display order are:

- STATUS
- SETPOINTS
- SYSTEM SETUP
- ADVANCED SETUP
- CHECKOUT
- ALARMS

IMPORTANT: Table 7 illustrates the complete hierarchy. Your menu parameters may be different depending on your configuration.

For example if you do not have a DCV (CO₂) sensor, then none of the DCV parameters appear and only MIN POS will display. If you have a CO₂ sensor, the DCV MIN and DCV MAX will appear AND if you have 2 speed fan DCV MIN (high and low speed) and DCV MAX (high and low speed will appear).

NOTE: Some parameters in the menus use the letters MA or MAT, indicating a mixed air temperature sensor location before the cooling coil. This unit application has the control sensor located after the cooling coil, in the fan section, where it is designated as (Cooling) Supply Air Temperature or SAT sensor.

SETUP AND CONFIGURATION — Before being placed into service, the W7220 Economizer module must be setup and configured for the installed system.

IMPORTANT: During setup, the economizer module is live at all times.

The setup process uses a hierarchical menu structure that is easy to use. Press the ▲ and ▼ arrow buttons to move forward and backward through the menus and press the button to select and confirm setup item changes.

TIME-OUT AND SCREENSAVER — When no buttons have been pressed for 10 minutes, the LCD displays a screen saver, which cycles through the Status items. Each Status items displays in turn and cycles to the next item after 5 seconds.

Table 7 — Menu Structure

MENU	PARAMETER	PARAMETER DEFAULT VALUE	PARAMETER RANGE AND INCREMENT	NOTES
STATUS	ECONO AVAIL	NO	YES/NO	FIRST STAGE COOLING DEMAND (Y1-IN) YES = economizing available; the system can use outside air for free cooling when required
	ECONOMIZING	NO	YES/NO	FIRST STAGE COOLING RELAY OUTPUT YES = outside air being used for 1 stage cooling
	OCCUPIED	NO	YES/NO	OCCUPIED YES = OCC signal received from space thermostat or unitary controller YES = 24 Vac on terminal OCC NO = 0 Vac on terminal OCC
	HEAT PUMP	N/A	COOL HEAT	HEAT PUMP MODE Displays COOL or HEAT when system is set to heat pump (Non-conventional)
	COOL Y1—IN	OFF	ON/OFF	FIRST STAGE COOLING DEMAND (Y1-IN) Y1-I signal from space thermostat or unitary controller for cooling stage 1. ON = 24 Vac on terminal Y1-I OFF = 0 Vac on terminal Y1-I
	COOL Y1—OUT	OFF	ON/OFF	FIRST STAGE COOLING RELAY OUTPUT Cool stage 1 Relay Output to stage 1 mechanical cooling (Y1—OUT terminal)
	COOL Y2—IN	OFF	ON/OFF	SECOND STAGE COOLING DEMAND (Y2-IN) Y2-I signal from space thermostat our unitary controller for second stage cooling. ON = 24 Vac on terminal Y2-I OFF = 0 Vac on terminal Y2-I
	COOL Y2—OUT	OFF	ON/OFF	SECOND STAGE COOLING RELAY OUTPUT Cool Stage 2 Relay Output to mechanical cooling (Y2—OUT terminal)
	MA TEMP	__ . __ F	0 to 140 F	SUPPLY AIR TEMPERATURE, Cooling Mode Displays value of measured mixed air from MAT sensor. Displays __ . __ F if not connected, short or out-of-range.
	DA TEMP	__ . __ F	0 to 140 F	DISCHARGE AIR TEMPERATURE, after Heating section Displays when Discharge Air sensor is connected and displays measured discharge temperature. Displays __ . __ F if sensor sends invalid value, if not connected, short or out-of-range.
	OA TEMP	__ . __ F	-40 to 140 F	OUTSIDE AIR TEMP Displays measured value of outdoor air temperature. Displays __ . __ F if sensor sends invalid value, short or out-of-range.
	OA HUM	__ %	0 to 100%	OUTSIDE AIR RELATIVE HUMIDITY Displays measured value of outdoor humidity from OA sensor. Displays __ % if not connected short, or out-of-range.
	RA TEMP	__ . __ F	0 to 140 F	RETURN AIR TEMPERATURE Displays measured value of return air temperature from RAT sensor. Displays __ . __ F if sensor sends invalid value, if not connected, short or out-of-range
	RA HUM	__ %	0 to 100%	RETURN AIR RELATIVE HUMIDITY Displays measured value of return air humidity from RA sensor. Displays __ % if sensor sends invalid value, if not connected, short or out-of-range
	IN CO2	___ ppm	0 TO 2000 ppm	SPACE/RETURN AIR CO ₂ Displays value of measured CO ₂ from CO ₂ sensor. Invalid if not connected, short or out-of-range
	DCV STATUS	N/A	ON/OFF	DEMAND CONTROLLED VENTILATION STATUS Displays ON if above setpoint and OFF if below setpoint, and ONLY if a CO ₂ sensor is connected.
	DAMPER OUT	2.0v	2.0 TO 10.0v	Displays voltage output to the damper actuator.
	ACT POS	N/A	0 to 100%	Displays actual position of outdoor air damper actuator

Table 7 — Menu Structure (cont)

MENU	PARAMETER	PARAMETER DEFAULT VALUE	PARAMETER RANGE AND INCREMENT	NOTES
STATUS (CONT)	ACT COUNT	N/A	1 to 65535	Displays number of times actuator has cycled. 1 cycles equals 180 deg. of actuator movement in any direction.
	ACTUATOR	N/A	OK/Alarm (on Alarm menu)	Displays ERROR if voltage or torque is below actuator range.
	EXH1 OUT	OFF	ON/OFF	EXHAUST STAGE 1 RELAY OUTPUT Output of EXH1 terminal: ON = relay closed OFF = relay open
	EXH2 OUT	OFF	ON/OFF	EXHAUST STAGE 2 RELAY OUTPUT Output of AUX terminal; displays only if AUX = EXH2
	ERV	OFF	ON/OFF	ENERGY RECOVERY VENTILATOR Output of AUX terminal; displays only if AUX = ERV
	MECH COOL ON or HEAT STAGES ON	0	0, 1, or 2	Displays stage of mechanical cooling that is active. Displays the stage of heat pump heating that is active.
	FAN SPEED	N/A	LOW or HIGH	SUPPLY FAN SPEED Displays speed setting of fan on a 2-speed fan unit.
	W (HEAT ON)	N/A	ON/OFF	HEAT DEMAND STATUS Displays status of heat demand on a 2-speed fan unit.
SETPOINTS	MAT SET	53F	38 to 65 F; increment by 1	SUPPLY AIR SETPOINT Setpoint determines where the economizer will modulate the OA damper to maintain the mixed air temperature.
	LOW T LOCK	32F	-45 to 80 F; increment by 1	COMPRESSOR LOW TEMPERATURE LOCKOUT Setpoint determines outdoor temperature when the mechanical cooling cannot be turned on. Commonly referred to as the Compressor lockout.
	DRYBLB SET	63F	48 to 80 F; increment by 1	OA DRY BULB TEMPERATURE CHANGEOVER SETPOINT Setpoint determines where the economizer will assume outdoor air temperature is good for free cooling; e.g.; at 63 F unit will economize at 62 F and below and not economize at 64 F and above. There is a 2 F dead-band.
	ENTH CURVE	ES3	ES1,ES2,ES3,ES4, or ES5	ENTHALPY CHANGEOVER CURVE Enthalpy boundary "curves" for economizing using single enthalpy.
	DCV SET	1100ppm	500 to 2000ppm; increment by 100	DEMAND CONTROLLED VENTILATION Displays only if CO ₂ sensor is connected. Setpoint for Demand Control Ventilation of space. Above the setpoint, the OA dampers will modulate open to bring in additional OA to maintain a space ppm level below the setpoint.
	MIN POS	2.8 V	2 to 10 Vdc	VENTILATION MINIMUM POSITION Displays ONLY if a CO ₂ sensor is NOT connected.
	VENTMAX With 2-speed fan units VENTMAX L (low speed fan) and VENTMAX H (high speed fan) settings are required	2.8 V	2 to 10 Vdc 100 to 9990 cfm; increment by 10	DCV MAXIMUM DAMPER POSITION Displays only if a CO ₂ sensor is connected. Used for Vbz (ventilation max cfm) setpoint. Displays 2 to 10 V if <3 sensors (RA,OA, and MA). In AUTO mode dampers controlled by CFM. If OA, MA, RA, and CO ₂ sensors are connected and DCV CAL ENABLE is set to AUTO mode, the OA dampers are controlled by CFM and displays from 100 to 9990 CFM.
	VENTMIN With 2-speed fan units VENTMIN L (low speed fan) and VENTMIN H (high speed fan) set	2.25 V	2 to 10 Vdc or 100 to 9990 cfm increment by 10 100 to 9990 cfm; increment by 10	DCV MINIMUM DAMPER POSITION Displays only if a CO ₂ sensor is connected. Used for Ba (ventilation min cfm) setpoint. Displays 2 to 10 V if <3 sensors (RA, OA, and MA). Va is only set if DCV is used. This is the ventilation for less than maximum occupancy of the space. In AUTO mode dampers controlled by CFM. If OA, MA, RA, and CO ₂ sensors are connected and DCV CAL ENABLE is set to AUTO mode, the OA dampers are controlled by CFM and displays from 100 to 9990 CFM.
	ERV OAT SP	32°F	0 to 50 F; increment by 1	ENERGY RECOVERY VENTILATOR UNIT OUTDOOR AIR TEMPERATURE SETPOINT Only when AUX1 O = ERV
	EXH1 SET With 2-speed fan units Exh1 L (low speed fan) and Exh1 H (high speed fan) settings are required	50%	0 to 100%;increment by 1	EXHAUST FAN STAGE 1 SETPOINT Setpoint for OA damper position when exhaust fan 1 is powered by the economizer. With 2-speed fan units Exh1 L (low speed fan) and Exh1 H (high speed fan) settings are required. Default for Exh1 L is 65% and Exh1 H is 50%
	EXH2 SET With 2-speed fan units Exh2 L (low speed fan) and Exh2 H (high speed fan) settings are required	75%	0 to 100%; increment by 1	EXHAUST FAN STAGE 2 SETPOINT Setpoint for OA damper position when exhaust fan 2 is powered by the economizer. Only used when AUX1 O is set to EHX2. With 2-speed fan units Exh2 L (low speed fan) and Exh2 H (high speed fan) settings are required. Default for Exh2 L is 80% and Exh2 H is 75%

Table 7 — Menu Structure (cont)

MENU	PARAMETER	PARAMETER DEFAULT VALUE	PARAMETER RANGE AND INCREMENT	NOTES
SYSTEM SETUP	INSTALL	01/01/10	N/A	Display order = MM/DD/YY Setting order = DD, MM, then YY.
	UNITS DEG	F	F or C	Sets economizer controller in degrees Fahrenheit or Celsius
	EQUIPMENT	CONV	Conventional or HP	CONV = conventional; HP O/B = Enable Heat Pump mode. Use AUX2 I for Heat Pump input from thermostat or controller. See Menu Note 7.
	AUX2 IN	W	SD/W or HP(O)/ HP(B)	In CONV mode: SD + Enables configuration of shutdown (default); W = Informs controller that system is in heating mode. NOTE: If using 2-speed fan mode, you must program CONV mode for W. Shutdown is not available in 2-speed fan mode. See Menu Note 7. In HP O/B mode: HP(O) = energize heat pump on Cool (default); HP(B) = energize heat pump on heat.
	FAN SPEED	2 speed	1 speed/2 speed	Sets the economizer controller for operation of 1 speed or 2 speed supply fan. NOTE: 2-speed fan option also needs Heat (W1) programmed in AUX 2 In. See Menu Note 7.
	FAN CFM	5000cfm	100 to 15000 cfm; increment by 100	UNIT DESIGN AIRFLOW (CFM) Enter only if using DCVAL ENA = AUTO The value is found on the nameplate label for the specific unit.
	AUX1 OUT	NONE	NONE ERV EXH2 SYS	Select OUTPUT for AUX1 O relay • NONE = not configured (output is not used) • ERV = Energy Recovery Ventilator • EXH2 = second damper position relay closure for second exhaust fan • SYS = use output as an alarm signal
	OCC	INPUT	INPUT or ALWAYS	OCCUPIED MODE BY EXTERNAL SIGNAL When using a setback thermostat with occupancy out (24 vac), the 24 vac is input "INPUT" to the OCC terminal. If no occupancy output from the thermostat then change program to "ALWAYS" OR add a jumper from terminal R to OCC terminal.
	FACTORY DEFAULT	NO	NO or YES	Resets all set points to factory defaults when set to YES. LCD will briefly flash YES and change to NO but all parameters will change to the factory default values. NOTE: RECHECK AUX2 IN and FANTYPE for required 2-speed values.
ADVANCED SETUP	MA LO SET	45°F	35 to 55 F; Incremented by 10	SUPPLY AIR TEMPERATURE LOW LIMIT Temperature to achieve Freeze Protection (close damper and alarm if temperature falls below setup value).
	FREEZE POS	CLO	CLO or MIN	FREEZE PROTECTION DAMPER POSITION Damper position when freeze protection is active (closed or MIN POS).
	CO2 ZERO	0ppm	0 to 500 ppm; Increment by 10	CO ₂ ppm level to match CO ₂ sensor start level.
	CO2 SPAN	2000ppm	1000 to 3000 ppm; Increment by 10	CO ₂ ppm span to match CO ₂ sensor.
	STG3 DLY	2.0h	0 min, 5 min, 15 min, then 15 min intervals. Up to 4 hrs or OFF	COOLING STAGE 3 DELAY Delay after stage 2 cool has been active. Turns on 2nd stage of cooling when economizer is 1st stage and mechanical cooling is 2nd stage. Allows three stages of cooling, 1 economizer and 2 mechanical. OFF = no Stage 3 cooling
	SD DMPR POS	CLO	CLO or OPN	Indicates shutdown signal from space thermostat or unitary controller. When controller receives 24 Vac input on the SD terminal in conventional mode, the OA damper will open if programmed for OPN and OA damper will close if programmed for CLO. All other controls, e.g., fans, etc. will shut off.
	DA LO ALM	45 F (7 C)	35 to 65 F; (2 to 18 C) Incremented by 5 deg.	Used for alarm for when the DA air temperature is too low. Set lower range of alarm, below this temperature the alarm will show on the display.
	DA HI ALM	80 F (27 C)	70 to 180 F; (21 to 82 C) Incremented by 5 deg.	Used for alarm for when the DA air temperature is too high. Set upper range of alarm, above this temperature the alarm will show on the display.
	DCVCAL ENA	MAN	MAN (manual) AUTO	Turns on the DCV automatic control of the dampers. Resets ventilation based on the RA, OA, and MA sensor conditions. Requires all 3 RA, OA, and MA sensors.

Table 7 — Menu Structure (cont)

MENU	PARAMETER	PARAMETER DEFAULT VALUE	PARAMETER RANGE AND INCREMENT	NOTES
ADVANCED SETUP (CONT)	MAT T CAL	0.0°F	±2.5 F	SUPPLY AIR TEMPERATURE CALIBRATION Allows for the operator to adjust for an out of calibration temperature sensor.
	OAS T CAL	0.0°F	±2.5 F	OUTSIDE AIR TEMPERATURE CALIBRATION Allows for the operator to adjust for an out of calibration temperature sensor.
	OA H CAL	0% RH	±10% RH	OUTSIDE AIR HUMIDITY CALIBRATION Allows for operator to adjust for an out of calibration humidity sensor.
	RA T CAL	0.0°F	±2.5 F	RETURN AIR TEMPERATURE CALIBRATION Allows for the operator to adjust for an out of calibration temperature sensor.
	RA H CAL	0% RH	±10% RH	RETURN AIR HUMIDITY CALIBRATION Allows for operator to adjust for an out of calibration humidity sensor.
	DA T CAL	0.0°F	±2.5 F	DISCHARGE AIR TEMPERATURE CALIBRATION Allows for the operator to adjust for an out of calibration temperature sensor.
	2SP FAN DELAY	5 Minutes	0 to 20 minutes in 1 minute increments	TIME DELAY ON 2nd STAGE ECONOMIZING When in economizing mode this is the delay for the high speed fan to try to satisfy the call for second stage cooling before the first stage mechanical cooling is enabled.
CHECKOUT	DAMPER MINIMUM POSITION	N/A	N/A	The checkout for the damper minimum position is based on the system. See Table 8.
	DAMPER OPEN	N/A	N/A	Position damper to the full open position. Exhaust fan contacts enable during the DAMPER OPEN test. Make sure you pause in the mode to allow exhaust contacts to energize due to the delay in the system.
	DAMPER CLOSE	N/A	N/A	Positions damper to the fully closed position
	CONNECT Y1-O	N/A	N/A	Closes the Y1-O relay (Y1-O)
	CONNECT Y2-O	N/A	N/A	Closes the Y2-O relay (Y2-O)
	CONNECT AUX1-O	N/A	N/A	Energizes the AUX output. If Aux setting is: • NONE — not action taken • ERV — 24 Vac out. Turns on or signals an ERV that the conditions are not good for economizing but are for ERV operation. • SYS — 24 Vac out. Issues a system alarm
ALARMS	Alarms display only when they are active. The menu title "ALARMS(#)" includes the number of active alarms in parenthesis (). When using SYLK bus sensors, "SYLK" will appear on the screen, and when using 20k OA temperature sensors, "SENS T" will appear on the screen			
	MAT SENS ERR	N/A	N/A	SUPPLY AIR TEMPERATURE SENSOR ERROR Mixed air sensor has failed or become disconnected - check wiring then replace sensor if the alarm continues.
	CO2 SENS ERR	N/A	N/A	CO ₂ SENSOR ERROR CO ₂ sensor has failed, gone out of range or become disconnected - check wiring then replace sensor if the alarm continues.
	OA SYLK T ERR	N/A	N/A	OUTSIDE AIR S-BUS SENSOR ERROR
	OA SYLK H ERR	N/A	N/A	Outdoor air enthalpy sensor has failed or become disconnected - check wiring then replace sensor if the alarm continues.
	RA SYLK T ERR	N/A	N/A	RETURN AIR S-BUS SENSOR ERROR
	RA SYLK H ERR	N/A	N/A	Return air enthalpy sensor has failed or become disconnected - check wiring then replace sensor if the alarm continues.
	DA SYLK T ERR	N/A	N/A	DISCHARGE AIR S-BUS SENSOR ERROR Discharge air sensor has failed or become disconnected - check wiring then replace sensor if the alarm continues.
	OA SENS T ERR	N/A	N/A	OUTSIDE AIR TEMPERATURE SENSOR ERROR Outdoor air temperature sensor has failed or become disconnected - check wiring then replace if the alarm continues.
	ACT ERROR	N/A	N/A	ACTUATOR ERROR Actuator has failed or become disconnected - check for stall, over voltage, under voltage and actuator count. Replace actuator if damper is movable and supply voltage is between 21.6 V and 26.4 V. Check actuator count on STATUS menu.
	FREEZE ALARM	N/A	N/A	Check if outdoor temperature is below the LOW Temp Lockout on setpoint menu. Check if Mixed air temperature on STATUS menu is below the Lo Setpoint on Advanced menu. When conditions are back in normal range then the alarm will go away.

Table 7 — Menu Structure (cont)

MENU	PARAMETER	PARAMETER DEFAULT VALUE	PARAMETER RANGE AND INCREMENT	NOTES
ALARMS (CONT)	SHUTDOWN ACTIVE	N/A	N/A	AUX2 IN is programmed for SHUTDOWN and 24 V has been applied to AUX2 IN terminal.
	DMP CAL RUNNING	N/A	N/A	DAMPER CALIBRATION ROUTINE RUNNING If DCV Auto enable has been programmed, when the W7220 is completing a calibration on the dampers, this alarm will display. Wait until the calibration is completed and the alarm will go away. Must have OA, MA and RA sensors for DCV calibration; set up in the Advanced setup menu.
	DA SENS ALM	N/A	N/A	DISCHARGE AIR TEMPERATURE SENSOR ALARM Discharge air temperature is out of the range set in the ADVANCED SETUP Menu. Check the temperature of the discharge air.
	SYS ALARM	N/A	N/A	When AUX1-0 is set to SYS and there is any alarm (e.g., failed sensors, etc.), the AUX1-0 terminal has 24 Vac out.
	ACT UNDER V	N/A	N/A	ACTUATOR VOLTAGE LOW Voltage received by actuator is above expected range.
	ACT OVER V	N/A	N/A	ACTUATOR VOLTAGE HIGH Voltage received by actuator is below expected range.
	ACT STALLED	N/A	N/A	ACTUATOR STALLED Actuator stopped before achieving commanded position.

LEGEND

- CLO** — Compressor Lockout
- ERV** — Energy Recovery Ventilator
- LCD** — Liquid Crystal Display
- MA** — Mixed Air
- MAT** — Mixed Air Temperature
- N/A** — Not Applicable
- OA** — Outdoor Air
- OAT** — Outdoor Air Temperature
- OCC** — Occupied
- RA** — Return Air
- RAT** — Return Air Temperature
- RTU** — Rooftop Unit
- SYS** — System

NOTES:

1. Table 7 illustrates the complete hierarchy. Your menu parameters may be different depending on your configuration. For example if you do not have a DCV (CO₂) sensor, then none of the DCV parameters appear.
2. When values are displayed, pressing and holding the ▲ or ▼ button causes the display to automatically increment.
3. ERV Operation: When in cooling mode AND the conditions are NOT OK for economizing - the ERV terminal will be energized. In the Heating mode, the ERV terminal will be energized when the OA is below the ERV OAT setpoint in the setpoint menu.

For damper minimum position settings and checkout menu readings, see Table 8. For dry bulb operation with a 1 speed indoor fan, with or without DCV, see Tables 9 and 10. For enthalpy operation with a 1 speed indoor fan, with or without DCV, see Tables 11 and 12. For dry bulb operation with a 2 speed indoor fan, with or without DCV, see Tables 13 and 14. For enthalpy operation with a 2 speed indoor fan, with or without DCV, see Tables 15 and 16.

4. STATUS —> OCCUPIED — The factory-standard Occupancy signal originates with a thermostat or other controller call for indoor fan operation at CTB terminal G. This signal passes through the Central Terminal Board's OCCUPIED jumper JMP1 to the ECONO connector and to the W7220's OCC input terminal. An external timeclock or relay is required to implement an Occupancy schedule on the economizer damper position.
5. STATUS —> MA TEMP, SETPOINTS —> MAT SET — The W7220 menu parameters and labels include designations MA, MAT and Mixed Air for the economizer cooling control sensor. On these rooftop units, the economizer control sensor is located downstream of the evaporator/indoor coil in the supply fan section where this sensor is designated as Supply Air Temperature (SAT) sensor.
6. SETPOINTS —> DRYBLB SET — This point is not displayed if a Return Air (differential) temperature sensor or an Outdoor Air enthalpy sensor is connected.
7. SYSTEM SETUP parameters must be configured as noted for 2-Speed unit operation:
EQUIPMENT = CONV
AUX2 IN = W
FAN SPEED = 2SPEED

Table 8 — Damper Minimum Position Settings and Readings on Checkout Menu

DEMAND CONTROLLED VENTILATION (CO ₂ SENSOR)	FAN SPEED	SETPOINTS	CHECKOUT
NO	1	MIN POS	VMAX-HS
		N/A	N/A
	2	MIN POS H	VMAX-HS
MIN POS L		VMAX-LS	
YES	1	VENT MIN	VMAX-HS
		VENT MAX	VMAX-HS
	2	VENT MIN H	VMAX-HS
		VENT MAX H	VMAX-LS
		VENT MIN L	N/A
		VENT MAX L	N/A

Table 9 — Dry Bulb Operation No DCV (CO₂ Sensor) — 1 Speed Fan

DEMAND CONTROLLED VENTILATION (DCV)	OUTSIDE AIR GOOD TO ECONOMIZE	Y1-I	Y2-I	FAN SPEED	Y1-O	Y2-O	OCCUPIED	UNOCCUPIED
NONE	NO	OFF	OFF	HIGH	0v/Off	0v/Off	MIN POS	Closed
		ON	OFF	HIGH	24v/On	0v/Off	MIN POS	Closed
		ON	ON	HIGH	24v/On	24v/On	MIN POS	Closed
NONE	YES	OFF	OFF	HIGH	0v/Off	0v/Off	MIN POS	Closed
		ON	OFF	HIGH	0v/Off	0v/Off	MIN POS to Full Open	Closed to Full-Open
		ON	ON	HIGH	24v/On	0v/Off*	MIN POS to Full Open	Closed to Full-Open

*With stage 3 delay (STG3 DLY) in Advanced setup menu can turn on second stage of mechanical cooling Y2-O after the delay if the call for Y1-I and Y2-I have not been satisfied.

Table 10 — Dry Bulb Operation With DCV (CO₂ Sensor) — 1 Speed Fan

DEMAND CONTROLLED VENTILATION (DCV)	OUTSIDE AIR GOOD TO ECONOMIZE	Y1-I	Y2-I	FAN SPEED	Y1-O	Y2-O	OCCUPIED	UNOCCUPIED
Below CO ₂ Set	No	OFF	OFF	HIGH	0v/Off	0v/Off	VENTMIN	Closed
		ON	OFF	HIGH	24v/On	0v/Off	VENTMIN	Closed
		ON	ON	HIGH	24v/On	24v/On	VENTMIN	Closed
	Yes	OFF	OFF	HIGH	0v/Off	0v/Off	VENTMIN	Closed
		ON	OFF	HIGH	0v/Off	0v/Off	VENTMIN to Full-Open	Closed to Full-Open
		ON	ON	HIGH	24v/On	0v/Off	VENTMIN to Full-Open	Closed to Full-Open
Above CO ₂ Set	No	OFF	OFF	HIGH	0v/Off	0v/Off	VENTMIN to VENTMAX	Closed
		ON	OFF	HIGH	24v/On	0v/Off	VENTMIN to VENTMAX	Closed
		ON	ON	HIGH	24v/On	24v/On	VENTMIN to VENTMAX	Closed
	Yes	OFF	OFF	HIGH	0v/Off	0v/Off	VENTMIN to VENTMAX	Closed
		ON	OFF	HIGH	0v/Off	0v/Off	VENTMIN to Full-Open	Closed to Full-Open
		ON	ON	HIGH	24v/On	0v/Off*	VENTMIN to Full-Open	Closed to Full-Open

*With stage 3 delay (STG3 DLY) in Advanced setup menu can turn on second stage of mechanical cooling Y2-O after the delay if the call for Y1-I and Y2-I have not been satisfied.

Table 11 — Enthalpy Operation No DCV (CO₂ Sensor) — 1 Speed Fan

DEMAND CONTROLLED VENTILATION (DCV)	OUTSIDE AIR GOOD TO ECONOMIZE	Y1-I	Y2-I	FAN SPEED	Y1-O	Y2-O	OCCUPIED	UNOCCUPIED
NONE	NO	OFF	OFF	HIGH	0v/Off	0v/Off	MIN POS	Closed
		ON	OFF	HIGH	24v/On	0v/Off	MIN POS	Closed
		ON	ON	HIGH	24v/On	24v/On	MIN POS	Closed
NONE	YES	OFF	OFF	HIGH	0v/Off	0v/Off	MIN POS	Closed
		ON	OFF	HIGH	0v/Off	0v/Off	MIN POS to Full Open	Closed to Full-Open
		ON	ON	HIGH	24v/On	0v/Off*	MIN POS to Full Open	Closed to Full-Open

*With stage 3 delay (STG3 DLY) in Advanced setup menu can turn on second stage of mechanical cooling Y2-O after the delay if the call for Y1-I and Y2-I have not been satisfied.

Table 12 — Enthalpy Operation With DCV (CO₂ Sensor) — 1 Speed Fan

DEMAND CONTROLLED VENTILATION (DCV)	OUTSIDE AIR GOOD TO ECONOMIZE	Y1-I	Y2-I	FAN SPEED	Y1-O	Y2-O	OCCUPIED	UNOCCUPIED
Below CO ₂ Set	No	OFF	OFF	HIGH	0v/Off	0v/Off	VENTMIN	Closed
		ON	OFF	HIGH	24v/On	0v/Off	VENTMIN	Closed
		ON	ON	HIGH	24v/On	24v/On	VENTMIN	Closed
	Yes	OFF	OFF	HIGH	0v/Off	0v/Off	VENTMIN	Closed
		ON	OFF	HIGH	0v/Off	0v/Off	VENTMIN to Full-Open	Closed to Full-Open
		ON	ON	HIGH	24v/On	0v/Off	VENTMIN to Full-Open	Closed to Full-Open
Above CO ₂ Set	No	OFF	OFF	HIGH	0v/Off	0v/Off	VENTMIN to VENTMAX	Closed
		ON	OFF	HIGH	24v/On	0v/Off	VENTMIN to VENTMAX	Closed
		ON	ON	HIGH	24v/On	24v/On	VENTMIN to VENTMAX	Closed
	Yes	OFF	OFF	HIGH	0v/Off	0v/Off	VENTMIN to VENTMAX	Closed
		ON	OFF	HIGH	0v/Off	0v/Off	VENTMIN to Full-Open	Closed to Full-Open
		ON	ON	HIGH	24v/On	0v/Off*	VENTMIN to Full-Open	Closed to Full-Open

*With stage 3 delay (STG3 DLY) in Advanced setup menu can turn on second stage of mechanical cooling Y2-O after the delay if the call for Y1-I and Y2-I have not been satisfied.

Table 13 — Dry Bulb Operation No DCV (CO₂ Sensor) — 2 Speed Fan

DEMAND CONTROLLED VENTILATION (DCV)	OUTSIDE AIR GOOD TO ECONOMIZE	Y1-I	Y2-I	FAN SPEED	Y1-O	Y2-O	OCCUPIED	UNOCCUPIED
NONE	NO	OFF	OFF	LOW	0v/Off	0v/Off	MIN POS	Closed
		ON	OFF	LOW	24v/On	0v/Off	MIN POS	Closed
		ON	ON	HIGH	24v/On	24v/On	MIN POS	Closed
NONE	YES	OFF	OFF	LOW	0v/Off	0v/Off	MIN POS	Closed
		ON	OFF	LOW	0v/Off	0v/Off	MIN POS to Full Open	Closed to Full-Open
		ON	ON	HIGH	24v/On	0v/Off*	MIN POS to Full Open	Closed to Full-Open

*With stage 3 delay (STG3 DLY) in Advanced setup menu can turn on second stage of mechanical cooling Y2-O after the delay if the call for Y1-I and Y2-I have not been satisfied.

Table 14 — Dry Bulb Operation With DCV (CO₂ Sensor) — 2 Speed Fan

DEMAND CONTROLLED VENTILATION (DCV)	OUTSIDE AIR GOOD TO ECONOMIZE	Y1-I	Y2-I	FAN SPEED	Y1-O	Y2-O	OCCUPIED	UNOCCUPIED
Below CO ₂ Set	No	OFF	OFF	LOW	0v/Off	0v/Off	VENTMIN	Closed
		ON	OFF	LOW	24v/On	0v/Off	VENTMIN	Closed
		ON	ON	HIGH	24v/On	24v/On	VENTMIN	Closed
	Yes	OFF	OFF	LOW	0v/Off	0v/Off	VENTMIN	Closed
		ON	OFF	LOW	0v/Off	0v/Off	VENTMIN to Full-Open	Closed to Full-Open
		ON	ON	HIGH	24v/On	0v/Off	VENTMIN to Full-Open	Closed to Full-Open
Above CO ₂ Set	No	OFF	OFF	LOW	0v/Off	0v/Off	VENTMIN to VENTMAX	Closed
		ON	OFF	LOW	24v/On	0v/Off	VENTMIN to VENTMAX	Closed
		ON	ON	HIGH	24v/On	24v/On	VENTMIN to VENTMAX	Closed
	Yes	OFF	OFF	LOW	0v/Off	0v/Off	VENTMIN to VENTMAX	Closed
		ON	OFF	LOW	0v/Off	0v/Off	VENTMIN to Full-Open	Closed to Full-Open
		ON	ON	HIGH	24v/On	0v/Off*	VENTMIN to Full-Open	Closed to Full-Open

*With stage 3 delay (STG3 DLY) in Advanced setup menu can turn on second stage of mechanical cooling Y2-O after the delay if the call for Y1-I and Y2-I have not been satisfied.

Table 15 — Enthalpy Operation No DCV (CO₂ Sensor) — 2 Speed Fan

DEMAND CONTROLLED VENTILATION (DCV)	OUTSIDE AIR GOOD TO ECONOMIZE	Y1-I	Y2-I	FAN SPEED	Y1-O	Y2-O	OCCUPIED	UNOCCUPIED
NO CO ₂ SENSOR	NO	OFF	OFF	LOW	0v/Off	0v/Off	MIN POS	Closed
		ON	OFF	LOW	24v/On	0v/Off	MIN POS	Closed
		ON	ON	HIGH	24v/On	24v/On	MIN POS	Closed
	YES	OFF	OFF	LOW	0v/Off	0v/Off	MIN POS	Closed
		ON	OFF	LOW	0v/Off	0v/Off	MIN POS to Full Open	Closed to Full-Open
		ON	ON	HIGH	24v/On	0v/Off*	MIN POS to Full Open	Closed to Full-Open

*With stage 3 delay (STG3 DLY) in Advanced setup menu can turn on second stage of mechanical cooling Y2-O after the delay if the call for Y1-I and Y2-I have not been satisfied.

Table 16 — Enthalpy Operation With DCV (CO₂ Sensor) — 2 Speed Fan

DEMAND CONTROLLED VENTILATION (DCV)	OUTSIDE AIR GOOD TO ECONOMIZE	Y1-I	Y2-I	FAN SPEED	Y1-O	Y2-O	OCCUPIED	UNOCCUPIED
Below CO ₂ Set	No	OFF	OFF	LOW	0v/Off	0v/Off	VENTMIN	Closed
		ON	OFF	LOW	24v/On	0v/Off	VENTMIN	Closed
		ON	ON	HIGH	24v/On	24v/On	VENTMIN	Closed
	Yes	OFF	OFF	LOW	0v/Off	0v/Off	VENTMIN	Closed
		ON	OFF	LOW	0v/Off	0v/Off	VENTMIN to Full-Open	Closed to Full-Open
		ON	ON	HIGH	24v/On	0v/Off	VENTMIN to Full-Open	Closed to Full-Open
Above CO ₂ Set	No	OFF	OFF	LOW	0v/Off	0v/Off	VENTMIN to VENTMAX	Closed
		ON	OFF	LOW	24v/On	0v/Off	VENTMIN to VENTMAX	Closed
		ON	ON	HIGH	24v/On	24v/On	VENTMIN to VENTMAX	Closed
	Yes	OFF	OFF	LOW	0v/Off	0v/Off	VENTMIN to VENTMAX	Closed
		ON	OFF	LOW	0v/Off	0v/Off	VENTMIN to Full-Open	Closed to Full-Open
		ON	ON	HIGH	24v/On	0v/Off*	VENTMIN to Full-Open	Closed to Full-Open

*With stage 3 delay (STG3 DLY) in Advanced setup menu can turn on second stage of mechanical cooling Y2-O after the delay if the call for Y1-I and Y2-I have not been satisfied.

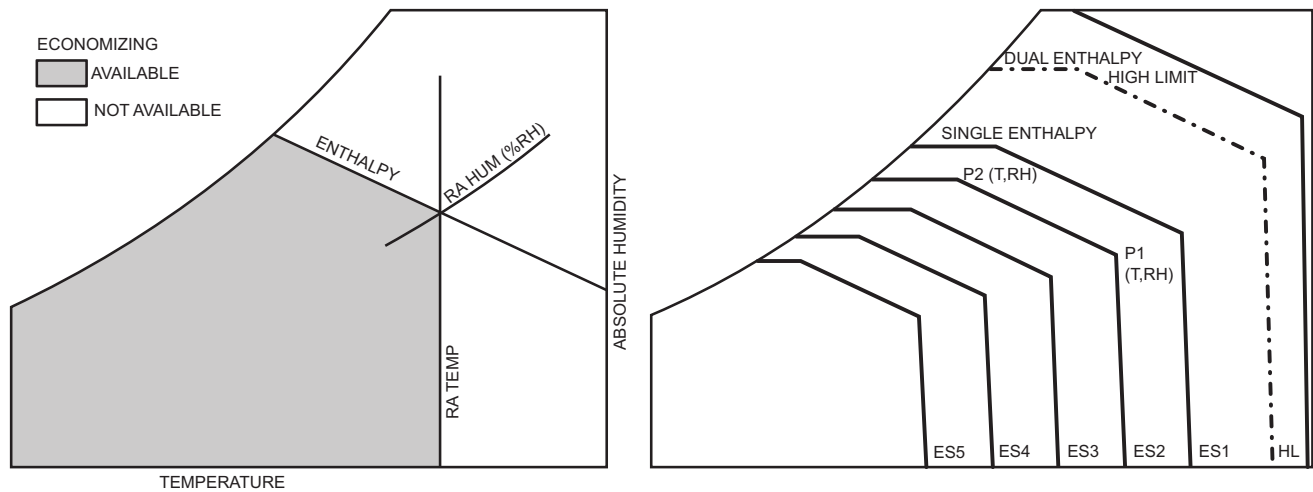

Fig. 51 — Single Enthalpy Curve Boundaries

Table 17 — Single Enthalpy and Dual Enthalpy High Limit Curves

ENTHALPY CURVE	TEMP. DRY BULB (F)	TEMP. DEWPOINT (F)	ENTHALPY (btu/lb/da)	POINT P1		POINT P2	
				TEMP. (F)	HUMIDITY (%RH)	TEMP. (F)	HUMIDITY (%RH)
ES1	80	60	28.0	80	36.8	66.3	80.1
ES2	75	57	26.0	75	39.6	63.3	80.0
ES3	70	54	24.0	70	42.3	59.7	81.4
ES4	65	51	22.0	65	44.8	55.7	84.2
ES5	60	48	20.0	60	46.9	51.3	88.5
HL	86	66	32.4	86	38.9	72.4	80.3

ENTHALPY SETTINGS — When the OA temperature, enthalpy and dew point are below the respective setpoints, the Outdoor Air can be used for economizing. Fig. 51 shows the new single enthalpy boundaries in the W7220. There are 5 boundaries (setpoints ES1 through ES5), which are defined by dry bulb temperature, enthalpy and dew point.

Refer to Table 17 for ENTH CURVE setpoint values.

The W7220 calculates the enthalpy and dew point using the OA temperature and humidity input from the OA enthalpy sensor. When the OA temperature, OA humidity and OA dew point are all below the selected boundary, the economizer sets the economizing mode to YES, economizing is available.

When all of the OA conditions are above the selected boundary, the conditions are not good to economize and the mode is set to NO.

Fig. 51 shows the 5 current boundaries. There is also a high limit boundary for differential enthalpy. The high limit boundary is ES1 when there are no stages of mechanical cooling energized and HL (high limit) when a compressor stage is energized.

Table 17 provides the values for each boundary limit.

TWO-SPEED FAN OPERATION — The W7220 controller has the capability to work with a system using a 2-speed supply fan. The W7220 does not control the supply directly but uses the following input status to determine the speed of the supply fan and controls the OA damper to the required position, see Table 18.

Table 18 — Fan Speed

STATE	FAN SPEED
OCC	Low
Y1	Low
Y2	High
W	High

The W (heating mode) is not controlled by the W7220 but it requires the status to know where to position the OA damper for minimum position for the fan speed.

The 2 speed fan delay is available when the system is programmed for 2 speed fan (in the System Setup menu item). The 2 speed fan delay is defaulted to 5 minutes and can be changed in the Advanced Setup menu item. When the unit has a call for Y1 In and in the free cooling mode and there is a call for Y2 In, the 2-speed fan delay starts and the OA damper will modulate 100% open, the supply fan should be set to high speed by the unit controller.

After the delay one of two actions will happen:

- The Y2 In call will be satisfied with the damper 100% open and fan on high speed and the call will turn off
- OR
- If the call for additional cooling in the space has not been satisfied then the first stage of mechanical cooling will be enabled through Y1 Out or Y2 Out.

CHECKOUT — Inspect all wiring connections at the economizer module’s terminals, and verify compliance with the installation wiring diagrams.

For checkout, review the Status of each configured parameter and perform the Checkout tests.

NOTE: For information about menu navigation and use of the keypad see Interface Overview on page 26.

TROUBLESHOOTING

WARNING

Failure to follow this warning could result in personal injury, property damage, or death.

Before performing service or maintenance operations on unit, always turn off main power switch to unit and install lock(s) and lockout tag(s). Unit may have more than one power switch. Ensure electrical service to rooftop unit agrees with voltage and amperage listed on the unit rating plate.

If any wiring changes are required, first be sure to remove power from the Economizer module before starting work. Pay particular attention to verifying the power connection (24 Vac).

Power Up — After the W7220 module is mounted and wired, apply power.

Initial Menu Display — On initial start up, Honeywell displays on the first line and economizer W7220 on the second line. After a brief pause, the revision of the software appears on the first line and the second line will be blank.

Power Loss (Outage or Brownout) — All setpoints and advanced settings are restored after any power loss or interruption.

NOTE: All settings are stored in non-volatile flash memory.

Status — Use the Status menu (see Table 7) to check the parameter values for the various devices and sensors configured.

NOTE: For information about menu navigation and use of the keypad see Interface Overview on page 26.

Checkout Tests — Use the Checkout menu (on page 31) to test the damper operation and any configured outputs. Only items that are configured are shown in the Checkout menu.

NOTE: For information about menu navigation and use of the keypad see Interface Overview on page 26.

To perform a Checkout test:

1. Scroll to the desired test in the Checkout menu using the ▲ and ▼ buttons.
2. Press the ←| button to select the item.
3. RUN? appears.
4. Press the ←| button to start the test.
5. The unit pauses and then displays IN PROGRESS.
6. When the test is complete, DONE appears.
7. When all desired parameters have been tested, press the ⏶ (Menu Up) button to end the test.

The Checkout tests can all be performed at the time of installation or at any time during the operation of the system as a test that the system is operable.

Alarms — The economizer module provides alarm messages that display on the 2-line LCD.

NOTE: Upon power up, the module waits 60 minutes before checking for alarms. This allows time for all the configured devices (e.g. sensors, actuator) to become operational. The exception is the SAT sensor which will alarm immediately.

If one or more alarms are present and there has been no keypad activity for at least 5 minutes, the Alarms menu displays and cycles through the active alarms.

You can also navigate to the Alarms menu at any time.

Clearing Alarms — Once the alarm has been identified and the cause has been removed (e.g. replaced faulty sensor) the alarm can be cleared from the display.

To clear an alarm, perform the following:

1. Navigate to the desired alarm.
2. Press the ←| button.
3. ERASE? displays.
4. Press the ←| button.
5. ALARM ERASED displays.
6. Press the (Menu up/Exit) button to complete the action and return to the previous menu.

NOTE: If the alarm still exists after you clear it, it is redisplayed within 5 seconds.

CAUTION

Failure to follow this caution may result in damage to equipment. Be sure to allow enough time for compressor start-up and shutdown between checkout tests so that you do not short-cycle the compressors.

Low Ambient Control (Factory Option) — If the unit comes with Electro-Mechanical (EM) control, then no adjustment is necessary.

If the unit comes with PremierLink™ or RTU Open control option, then refer to its installation control manual for details on adjusting “Cooling Lock-Out” setting and configure for your specific job requirements.

Staged Air Volume (SAV™) with Variable Frequency Drive (Factory Option) — For details on operating 50HC 2 stage cooling units equipped with the factory-installed Staged Air Volume option, refer to the Variable Frequency Drive (VFD) Installation, Start-Up and Service Instructions.

ComfortLink Controls (Factory Option) — For details on operating 50HC units equipped with the factory-installed ComfortLink controls option, refer to Controls, Start-Up, Operation and Troubleshooting for 48/50HC 04-28 Single Package Rooftop Unit with ComfortLink Controls.

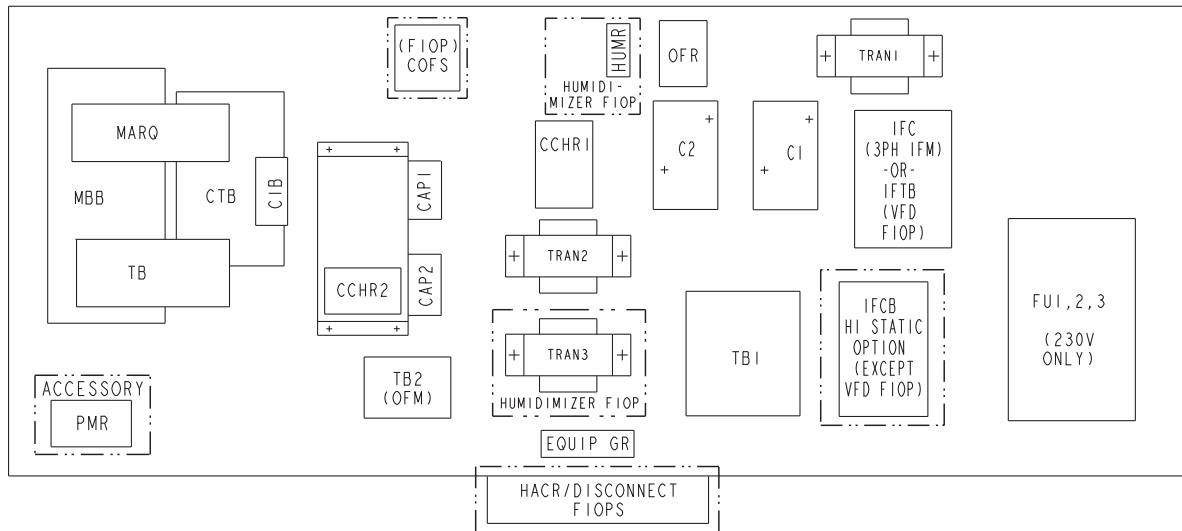

Fig. 52 — 50HC14 Control Box Component Locations with ComfortLink Controls

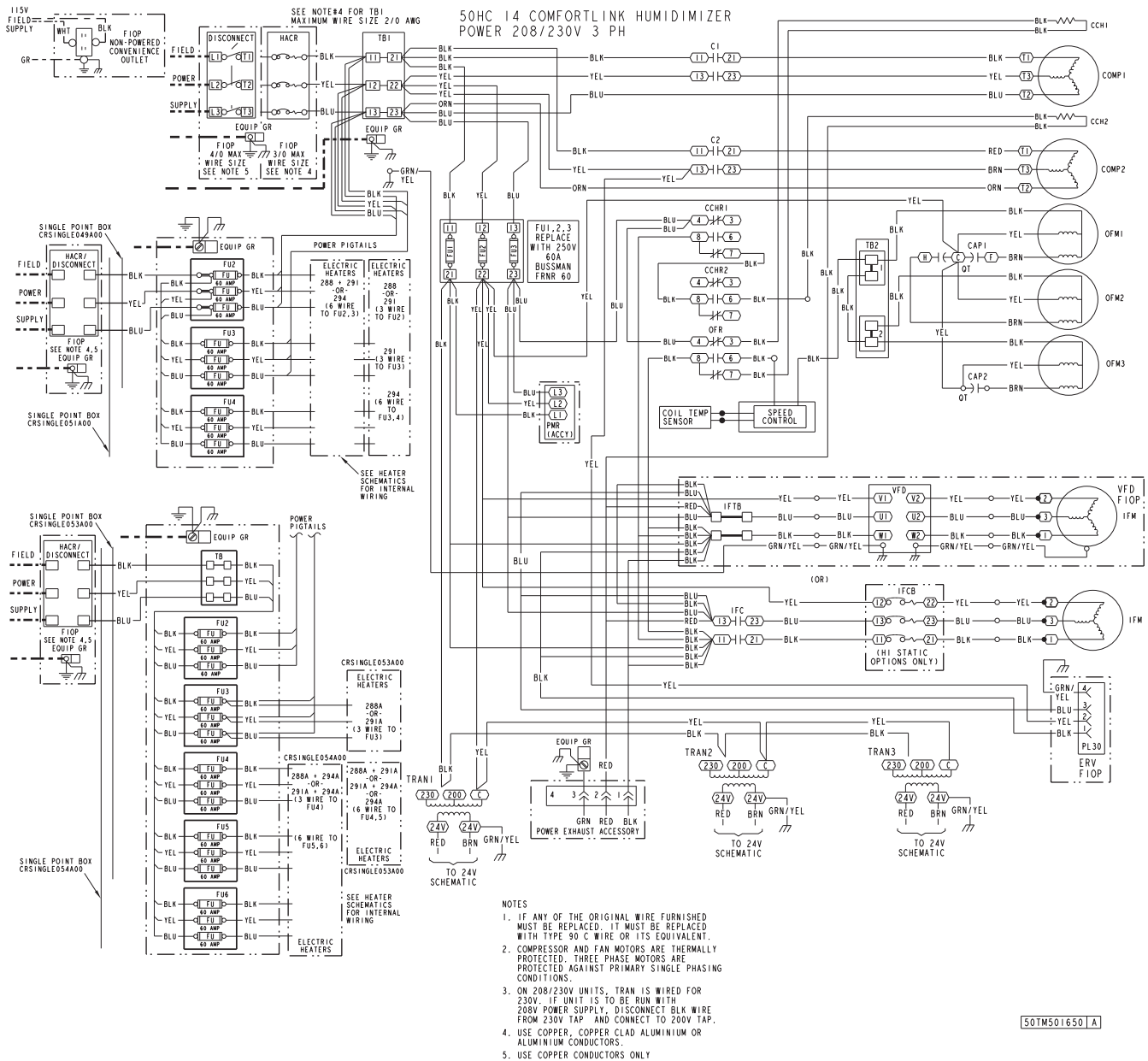

Fig. 55 — 50HC14 ComfortLink with Humidi-MiZer® Power Wiring Diagram

PremierLink™ Controller (Factory Option)

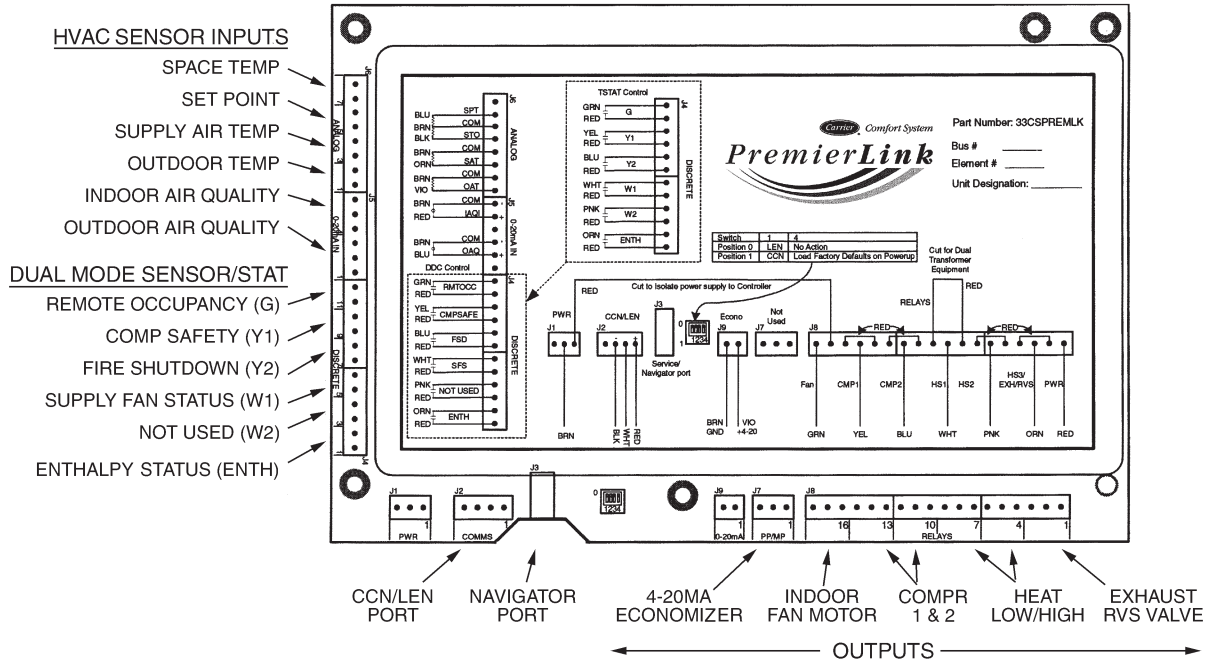

Fig. 56 — PremierLink™ Controller

The PremierLink controller (see Fig. 56) is compatible with Carrier Comfort Network® (CCN) devices. This control is designed to allow users the access and ability to change factory-defined settings, thus expanding the function of the standard unit control board. CCN service access tools include System Pilot™, Touch Pilot™ and Service Tool. (Standard tier display tools Navigator™ and Scrolling Marquee are not suitable for use with latest PremierLink controller (Version 2.x).)

The PremierLink controller is factory-mounted in the 50HC**14 unit's main control box to the left of the Central Terminal Board (CTB) (see Fig. 57). Factory wiring is completed through harnesses connected to the CTB thermostat. Field connections are made at a 16-pole terminal block (TB3) located on the bottom shelf of the unit control box in front of

the PremierLink controller. The factory-installed PremierLink controller includes the supply-air temperature (SAT) sensor. The outdoor air temperature (OAT) sensor is included in the FIOP/accessory EconoMiSer 2 package.

The PremierLink controller requires the use of a Carrier electronic thermostat or a CCN connection for time broadcast to initiate its internal timeclock. This is necessary for broadcast of time of day functions (occupied/unoccupied).

NOTE: PremierLink controller is shipped in Sensor mode. To be used with a thermostat, the PremierLink controller must be configured to Thermostat mode. Refer to PremierLink Configuration instructions for Operating Mode.

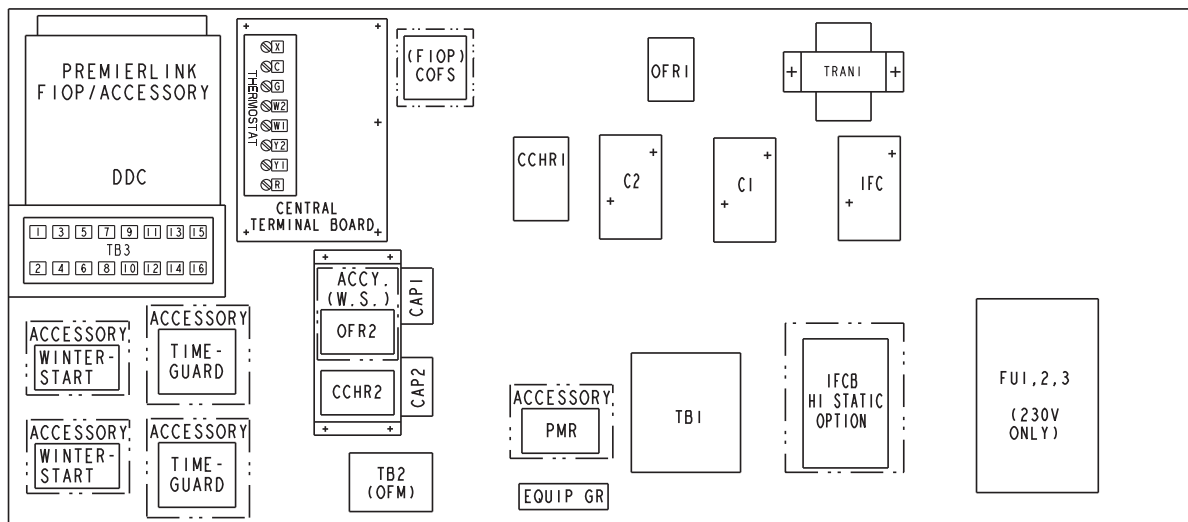

Fig. 57 — 50HC14 Control Box Component Locations — PremierLink Controller Location**

PAC CONTROL 208/230V, 460V, 575V
3 OFM DUAL COMPRESSOR

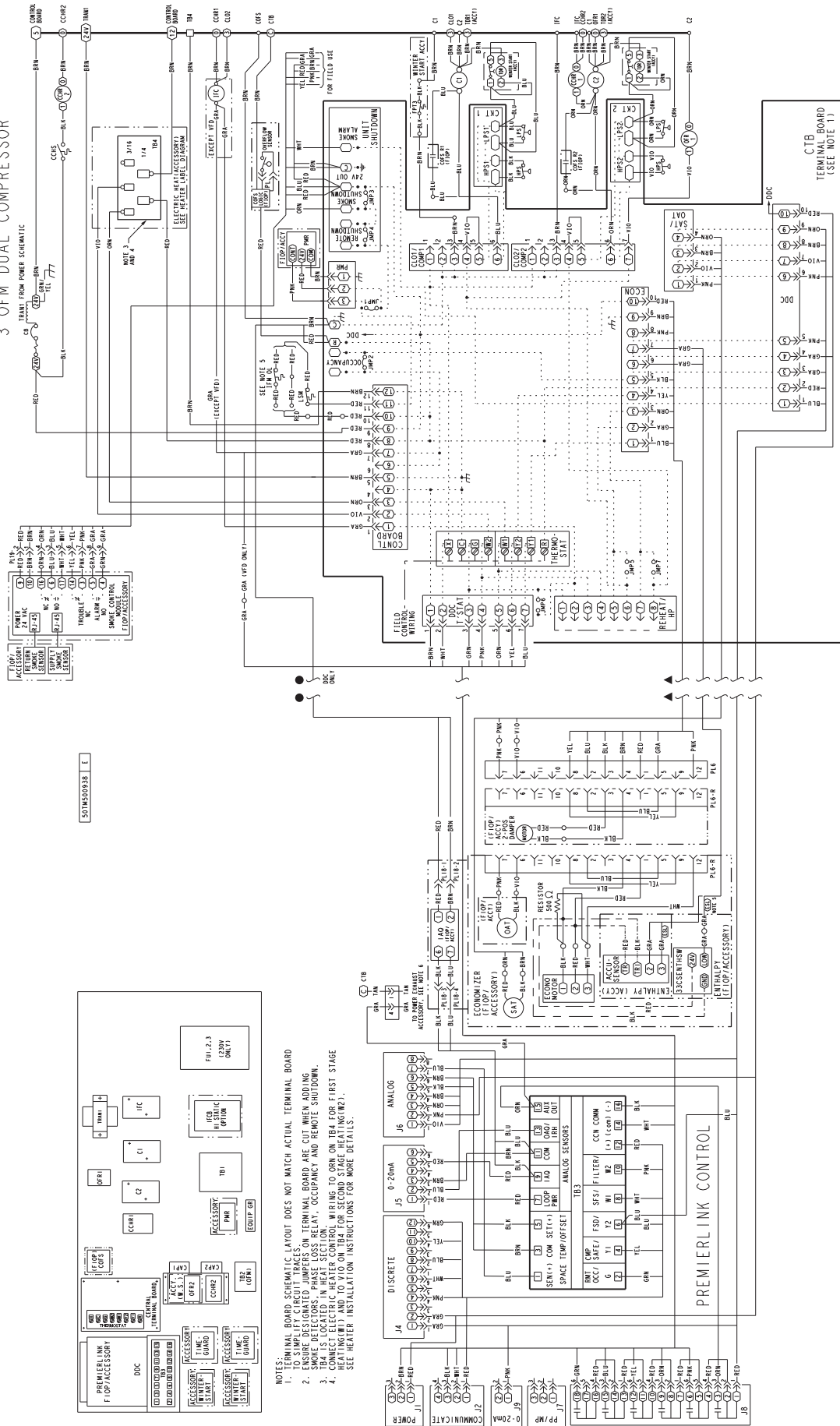
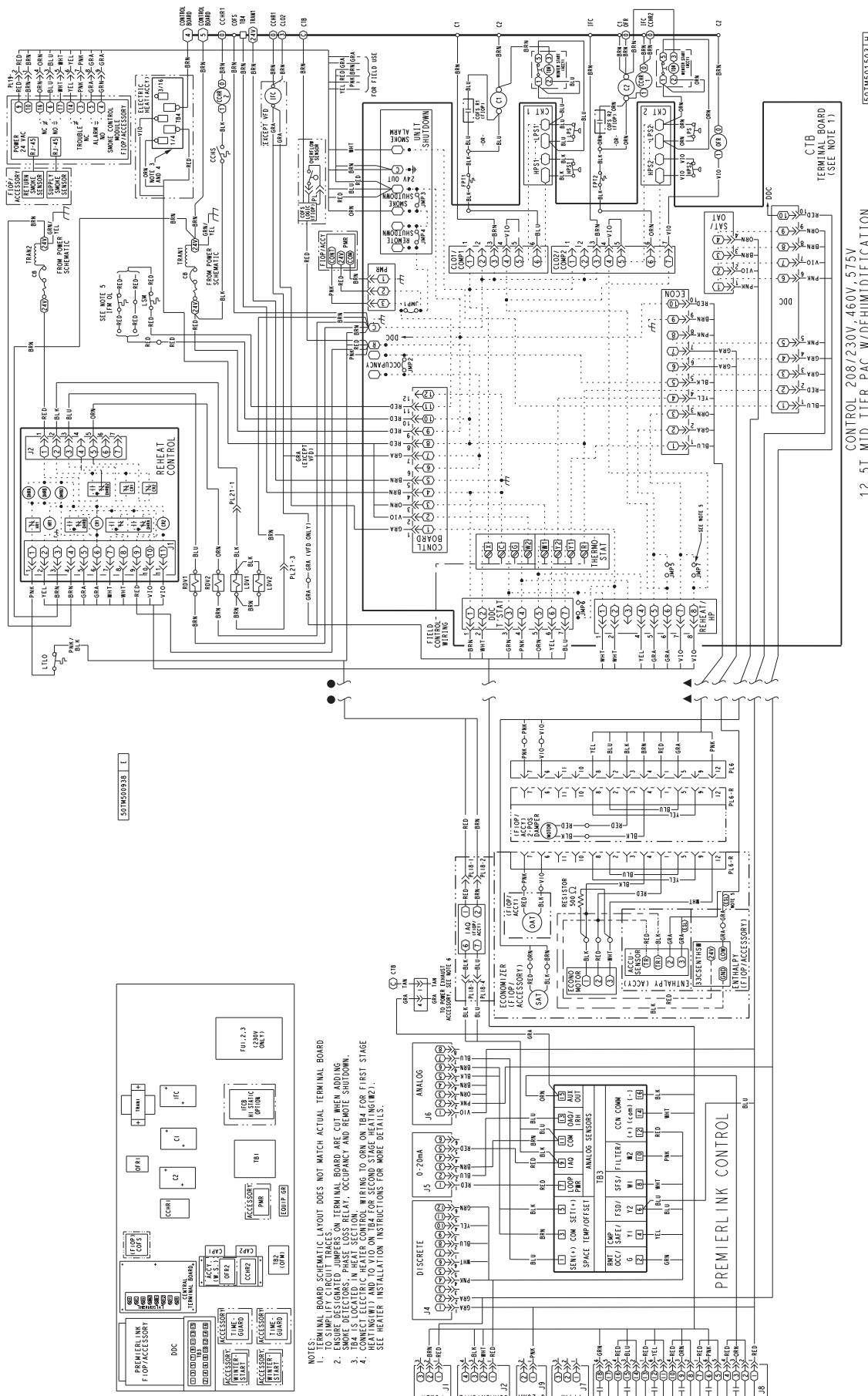

Fig. 58 — PremierLink Wiring Schematic



- NOTES:
1. TERMINAL BOARD SCHEMATIC LAYOUT DOES NOT MATCH ACTUAL TERMINAL BOARD TO SIMPLIFY CIRCUIT TRACES.
 2. WIRE COLOR IN TERMINAL BOARD ARE CUT WHEN ADDING SMOKE DETECTORS, PHASE LOSS RELAY, OCCUPANCY AND REMOTE SHUTDOWN.
 3. TBA-1 IS LOCATED IN HEAT SECTION. WIRING TO CON ON TBA FOR FIRST STAGE.
 4. WIRING TO TBA-2 AND TBA-3 FOR SECOND STAGE. SEE HEATER INSTALLATION INSTRUCTIONS FOR MORE DETAILS.

Fig. 59 — PremierLink™ Wiring Schematic with Humidi-MiZer® System Option

CONTROL 208/230V, 460V, 575V
12.5T MID TIER PAC W/DEHUMIDIFICATION

50TMS015031H

Supply Air Temperature (SAT) Sensor — On FIOP-equipped 50HC**14 units, the unit is supplied with a supply-air temperature (SAT) sensor (33ZCSENSAT). This sensor is a tubular probe type, approx 6-inches (152 mm) in length. It is a nominal 10k ohm thermistor.

The SAT is factory-wired. The SAT probe is wire-tied to the supply-air opening (on the horizontal opening end) in its shipping position. Remove the sensor for installation. Re-position the sensor in the flange of the supply-air opening or in the supply air duct (as required by local codes). Drill or punch a 1/2-in. hole in the flange or duct. Use the template provided in the unit control box. Use two field-supplied, self-drilling screws to secure the sensor probe in a horizontal orientation. See Fig. 60.

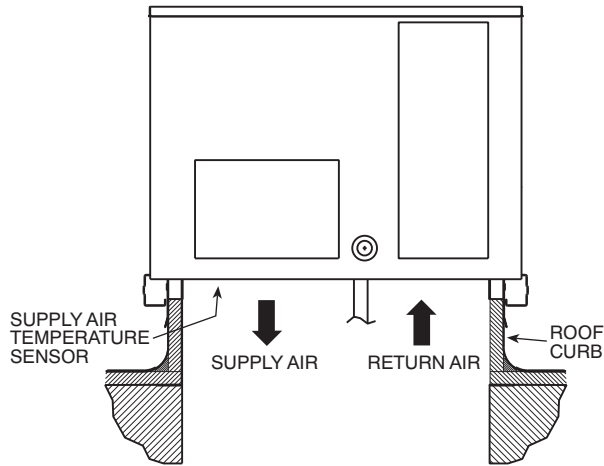

Fig. 60 — Typical Mounting Location for Supply Air Temperature (SAT) Sensor on Small Rooftop Units

NOTE: Refer to PremierLink Controller Installation, Start-up, and Configuration Instructions for complete PremierLink controller configuration, operating sequences and troubleshooting information. Have a copy of this manual available at unit set-up.

NOTE: The sensor must be mounted in the discharge airstream downstream of the cooling coil and any heating devices. Be sure the probe tip does not come in contact with any of the unit's heater surfaces.

OUTDOOR AIR TEMPERATURE (OAT) SENSOR — The OAT is factory-mounted in the EconoMiSer2 (FIOP or accessory). It is a nominal 10k ohm thermistor attached to an eyelet mounting ring.

ECONOMISER2 — The PremierLink controller is used with EconoMiSer2 (option or accessory) for outdoor air management. The damper position is controlled directly by the PremierLink controller; EconoMiSer2 has no internal logic device.

Outdoor air management functions can be enhanced with field-installation of these accessory control devices:

- Enthalpy control (outdoor air or differential sensors)
- Space CO₂ sensor
- Outdoor air CO₂ sensor

Refer to Table 19 for accessory part numbers.

Field Connections — Field connections for accessory sensor and input devices are made at the 16-pole terminal block (TB3) located beneath the PremierLink controller (See Fig. 58). Some input devices also require a 24-vac signal source; connect at CTB terminal R at "THERMOSTAT" connection strip for this signal source. See connections figures on following pages for field connection locations (and for continued connections at the PremierLink controller board inputs). Route wires to control box as indicated in Fig. 37.

Table 20 provides a summary of field connections for units equipped with Space Sensor. Table 21 provides a summary of field connections for units equipped with Space Thermostat.

Table 19 — PremierLink Controller Sensor Usage

APPLICATION	OUTDOOR AIR TEMPERATURE SENSOR	RETURN AIR TEMPERATURE SENSOR	OUTDOOR AIR ENTHALPY SENSOR	RETURN AIR ENTHALPY SENSOR
Differential Dry Bulb Temperature with PremierLink (PremierLink requires 4-20 mA Actuator)	Included — CRTEMPSN001A00	Required — 33ZCT55SPT or equivalent	—	—
Single Enthalpy with PremierLink (PremierLink requires 4-20mA Actuator)	Included — Not Used	—	Requires — 33CSENTHSW	—
Differential Enthalpy with PremierLink (PremierLink requires 4-20mA Actuator)	Included — Not Used	—	Requires — 33CSENTHSW or equivalent	Requires — 33CSENSEN or equivalent

NOTES:
 CO₂ Sensors (Optional):
 33ZCSENCO2 — Room sensor (adjustable). Aspirator box is required for duct mounting of the sensor.
 33ZCASPCO2 — Aspirator box used for duct-mounted CO₂ room sensor.

33ZCT55CO2 — Space temperature and CO₂ room sensor with override.
 33ZCT56CO2 — Space temperature and CO₂ room sensor with override and setpoint.

Table 20 — Space Sensor Mode

TB3 TERMINAL	FIELD CONNECTION	INPUT SIGNAL
1	T55—SEN/T56—SEN	Analog (10k thermistor)
2	RMT OCC	Discrete, 24VAC
3	T55—SEN/T56—SEN	Analog (10k thermistor)
4	CMPSAFE	Discrete, 24VAC
5	T56—SET	Analog (10k thermistor)
6	FSD	Discrete, 24VAC
7	LOOP—PWR	Analog, 24VDC
8	SPS	Discrete, 24VAC
9	IAQ—SEN	Analog, 4-20mA
10	FILTER	Discrete, 24VAC
11	IAQ—COM/OAQ—COM/RH—COM	Analog, 4-20mA
12	CCN + (RED)	Digital, 5VDC
13	OAQ—SEN/RH—SEN	Analog, 4-20mA
14	CCN Gnd (WHT)	Digital, 5VDC
15	AUX OUT(Power Exhaust)	(Output) Discrete 24VAC
16	CCN —(BLK)	Digital, 5VDC

LEGEND

- CCN — Carrier Comfort Network (communication bus)
- CMPSAFE — Compressor Safety
- FILTER — Filter Switch
- FSD — Fire Shutdown
- IAQ — Indoor Air Quality (CO₂)
- OAQ — Outdoor Air Quality (CO₂)
- RH — Relative Humidity
- SFS — Supply Fan Status
- T55 — Space Temperature Sensor
- T56 — Space Temperature Sensor

Table 21 — Thermostat Mode

TB3 TERMINAL	FIELD CONNECTION	INPUT SIGNAL
1	RAT SEN	Analog (10k thermistor)
2	G	Discrete, 24VAC
3	RAT SEN	Analog (10k thermistor)
4	Y1	Discrete, 24VAC
5	—	—
6	Y2	Discrete, 24VAC
7	LOOP—PWR	Analog, 24VDC
8	W1	Discrete, 24VAC
9	IAQ—SEN	Analog, 4-20mA
10	W2	Discrete, 24VAC
11	IAQ—COM/OAQ—COM/RH—COM	Analog, 4-20mA
12	CCN + (RED)	Digital, 5VDC
13	OAQ—SEN/RH—SEN	Analog, 4-20mA
14	CCN Gnd (WHT)	Digital, 5VDC
15	AUX OUT (Power Exhaust)	(Output) Discrete 24VAC
16	CCN — (BLK)	Digital, 5VDC

LEGEND

- CCN — Carrier Comfort Network (communication bus)
- G — Thermostat Fan
- IAQ — Indoor Air Quality (CO₂)
- OAQ — Outdoor Air Quality (CO₂)
- RAT — Return Air Temperature
- RH — Relative Humidity
- W1 — Thermostat Heat Stage 1
- W2 — Thermostat Heat Stage 2
- Y1 — Thermostat Cool Stage 1
- Y2 — Thermostat Cool Stage 2

SPACE SENSORS — The PremierLink™ controller is factory-shipped configured for Space Sensor Mode. A Carrier T-55 or T-56 space sensor must be used. T-55 space temperature sensor provides a signal of space temperature to the PremierLink controller. T-56 provides same space temperature signal plus it allows for adjustment of space temperature setpoints from the face of the sensor by the occupants.

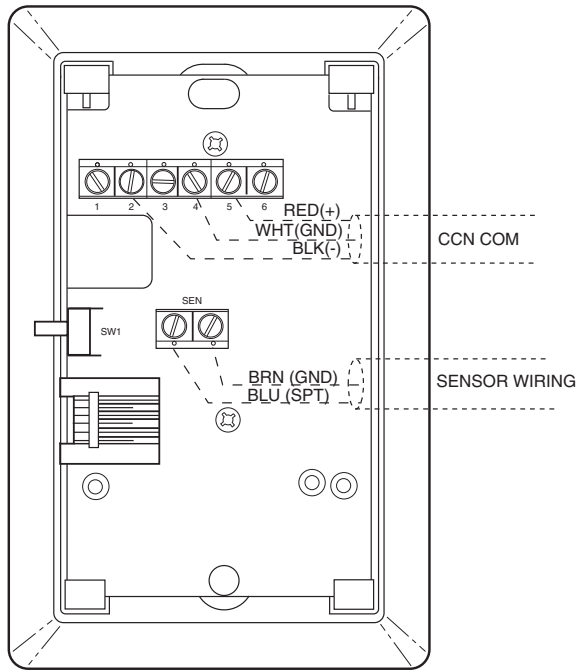

Fig. 61 — T-55 Space Temperature Sensor Wiring

Connect T-55 — See Fig. 61 for typical T-55 internal connections. Connect the T-55 SEN terminals to TB3 terminals 1 and 3 (see Fig. 62).

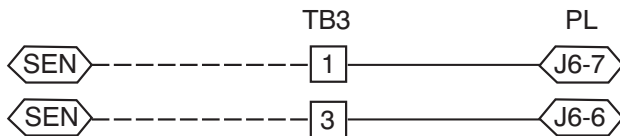

Fig. 62 — PremierLink Controller T-55 Sensor

Connect T-56 — See Fig. 63 for T-56 internal connections. Install a jumper between SEN and SET terminals as illustrated. Connect T-56 terminals to TB3 terminals 1, 3 and 5 (see Fig. 64).

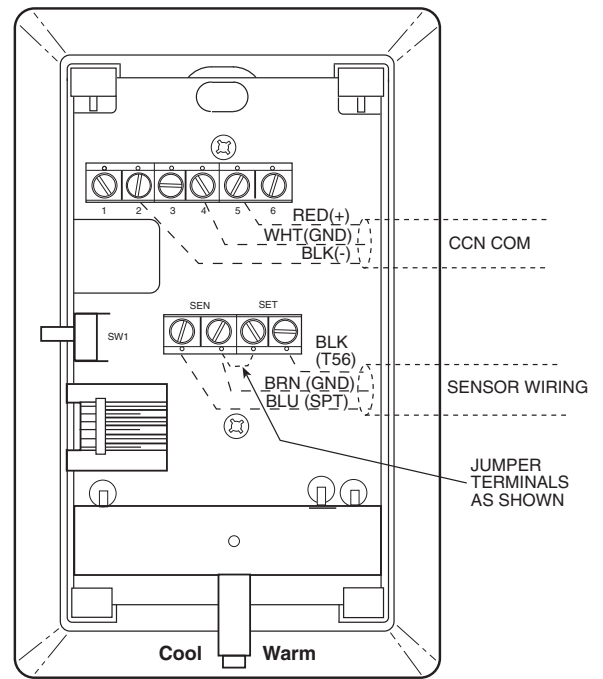

Fig. 63 — T-56 Internal Connections

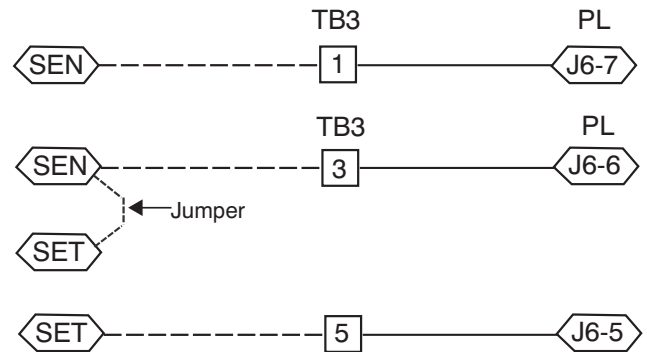

Fig. 64 — PremierLink Controller T-56 Sensor

CONNECT THERMOSTAT — A 7-wire thermostat connection requires a 24-v power source and a common connection. Use the R and C terminals on the CTBT's THERMOSTAT connection strip for these. Connect the thermostat's Y1, Y2, W1, W2 and G terminals to PremierLink TB3 as shown in Fig. 65.

If the 50HC**14 unit is equipped with factory-installed smoke detector(s), disconnect the factory BLU lead at TB3-6 (Y2) before connecting the thermostat. Identify the BLU lead originating at CTB-DDC-1; disconnect at TB3-6 and tape off. Confirm that the second BLU lead at TB3-6 remains connected to PremierLink J4-8.

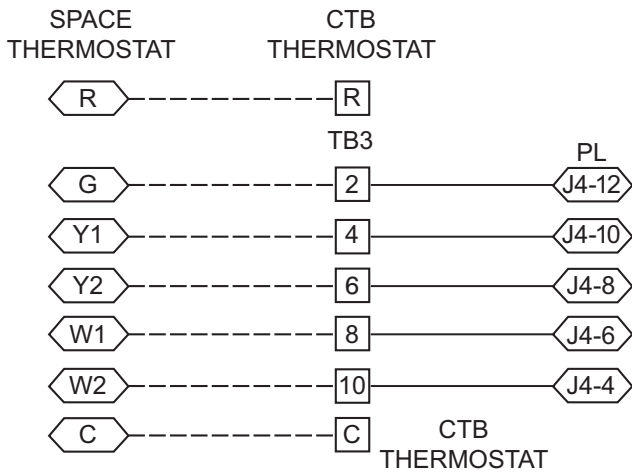

Fig. 65 — Space Thermostat Connections

If the 50HC**14 unit has an economizer system and free-cooling operation is required, a sensor representing Return Air Temperature must also be connected (field-supplied and installed). This sensor may be a T-55 Space Sensor (see Fig. 61) installed in the space or in the return duct, or it may be sensor P/N 33ZCSENSAT, installed in the return duct. Connect this sensor to TB3-1 and TB3-3 per Fig. 62.

CONFIGURE THE UNIT FOR THERMOSTAT MODE — Connect to the CCN bus using a CCN service tool and navigate to PremierLink Configuration screen for Operating Mode. Default setting is Sensor Mode (value 1). Change the value to 0 to reconfigure the controller for Thermostat Mode.

When the PremierLink controller is configured for Thermostat Mode, these functions are not available: Fire Shutdown (FSD), Remote Occupied (RMTOCC), Compressor Safety (CMPSAFE), Supply Fan Status (SFS), and Filter Pressure Switch (FILTER).

Economizer Controls

INDOOR AIR QUALITY (CO₂) SENSOR — The indoor air quality sensor accessory monitors space carbon dioxide (CO₂) levels. This information is used to monitor IAQ levels. Several types of sensors are available, for wall mounting in the space or in return duct, with and without LCD display, and in combination with space temperature sensors. Sensors use infrared technology to measure the levels of CO₂ present in the space air.

The CO₂ sensors are all factory set for a range of 0 to 2000 ppm and a linear mA output of 4 to 20. Refer to the instructions supplied with the CO₂ sensor for electrical requirements and terminal locations. See Fig. 66 for typical CO₂ sensor wiring schematic.

To accurately monitor the quality of the air in the conditioned air space, locate the sensor near a return-air grille (if present) so it senses the concentration of CO₂ leaving the space. The sensor should be mounted in a location to avoid direct breath contact.

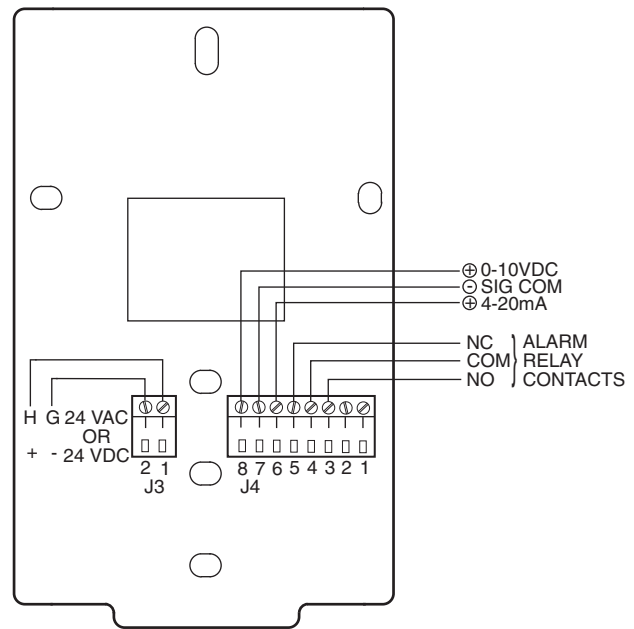

Fig. 66 — Indoor/Outdoor Air Quality (CO₂) Sensor (33ZCSENSO2) — Typical Wiring Diagram

Do not mount the IAQ sensor in drafty areas such as near supply ducts, open windows, fans, or over heat sources. Allow at least 3 ft (0.9 m) between the sensor and any corner. Avoid mounting the sensor where it is influenced by the supply air; the sensor gives inaccurate readings if the supply air is blown directly onto the sensor or if the supply air does not have a chance to mix with the room air before it is drawn into the return airstream.

Wiring the Indoor Air Quality Sensor — For each sensor, use two 2-conductor 18 AWG (American Wire Gage) twisted-pair cables (unshielded) to connect the separate isolated 24 vac power source to the sensor and to connect the sensor to the control board terminals.

To connect the sensor to the control, identify the positive (4 to 20 mA) and ground (SIG COM) terminals on the sensor. See Fig. 66. Connect the 4-20 mA terminal to terminal TB3-9 and connect the SIG COM terminal to terminal TB3-11. See Fig. 67.

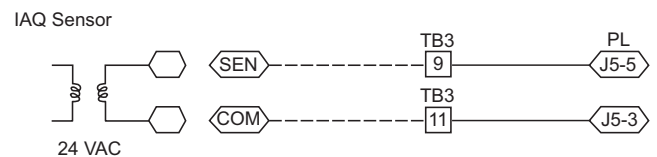

Fig. 67 — Indoor CO₂ Sensor (33ZCSENSO2) Connections

Refer to PremierLink Controller Installation, Start-up, and Configuration Instructions, for detailed configuration information.

OUTDOOR AIR QUALITY SENSOR (P/N 33ZCSENSO2 PLUS WEATHERPROOF ENCLOSURE) — The outdoor air CO₂ sensor is designed to monitor carbon dioxide (CO₂) levels in the outside ventilation air and interface with the ventilation damper in an HVAC system. The OAQ sensor is packaged with an outdoor cover. See Fig. 68. The outdoor air CO₂ sensor must be located in the economizer outside air hood.

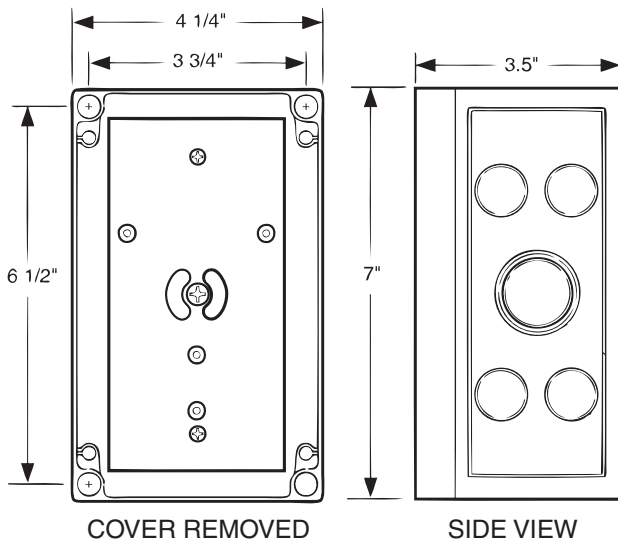

Fig. 68 — Outdoor Air Quality Sensor Cover

Wiring the Outdoor Air CO₂ Sensor — A dedicated power supply is required for this sensor. A two-wire cable is required to wire the dedicated power supply for the sensor. The two wires should be connected to the power supply and terminals 1 and 2.

To connect the sensor to the control, identify the positive (4 to 20 mA) and ground (SIG COM) terminals on the OAQ sensor. See Fig. 66. Connect the 4 to 20 mA terminal to the TB3-13 terminal of the 50HC**14. Connect the SIG COM terminal to the TB3-11 terminal of the 50HC**14. See Fig. 69.

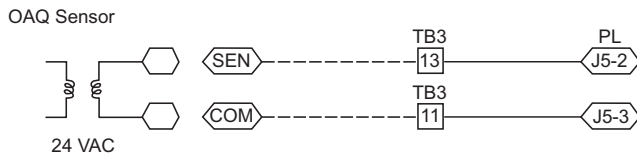

Fig. 69 — Outdoor CO₂ Sensor Connections

SPACE RELATIVE HUMIDITY SENSOR OR HUMIDISTAT CONNECTIONS

Space Relative Humidity Sensor connections — The accessory space relative humidity sensor (33ZCSENSRH-01) is installed on an interior wall to measure the relative humidity of the air within the occupied space.

The use of a standard 2 X 4 inch electrical box to accommodate the wiring is recommended for installation. The sensor can be mounted directly on the wall, if acceptable by local codes.

⚠ CAUTION

UNIT DAMAGE HAZARD

Failure to follow this caution may result in permanent damage to the sensor.

DO NOT clean or touch the sensing element with chemical solvents as they can permanently damage the sensor.

IMPORTANT: UNIT PERFORMANCE HAZARD

Failure to follow this caution will result in inaccurate sensor readings.

DO NOT mount the sensor in drafty areas such as near heating or air-conditioning ducts, open windows, fans, or over heat sources such as baseboard heaters, radiators, or wall-mounted dimmers. Sensors mounted in those areas will produce inaccurate readings.

If the sensor is installed directly on a wall service, install the humidity sensor using 2 screws and 2 hollow wall anchors (field supplied). Do not over tighten screws. See Fig. 70.

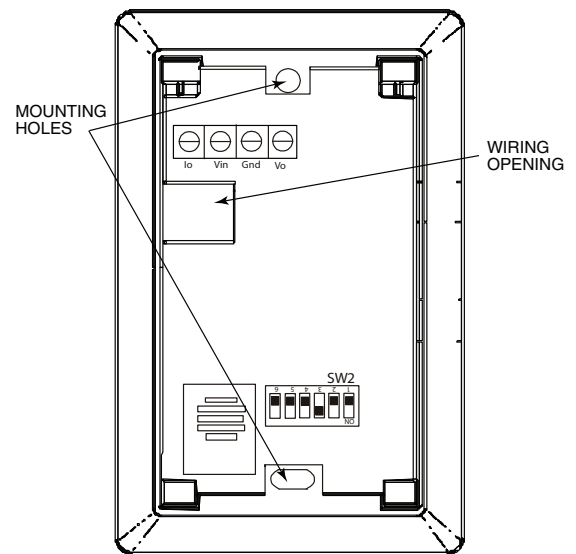

Fig. 70 — Space Relative Humidity Sensor Installation

The sensor must be mounted vertically on the wall. The Carrier logo should be orientated correctly when the sensor is properly mounted.

Avoid corner locations. Allow at least 4 ft between the sensor and any corner. Airflow near corners tends to be reduced, resulting in erratic sensor readings. The sensor should be vertically mounted approximately 5 ft up from the floor, beside the space temperature sensor.

For wiring distances up to 500 feet, use a 3-conductor, 18 or 20 AWG cable. A CCN communication cable can be used, although the shield is not required. The shield must be removed from the sensor end of the cable if this cable is used. See Fig. 71 for wiring details.

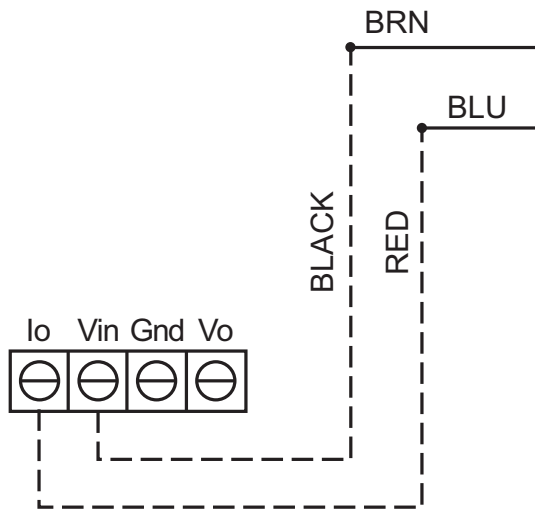

Fig. 71 — Space Relative Humidity Sensor Connection

The power for the sensor is provided by the PremierLink™ controller on terminal J5-4 (+33 to +35vdc).

To wire the sensor:

1. At the sensor, remove 4 inches of the jacket from the cable. Strip 1/4 inch of insulation from each conductor. Route the cable through the wire clearance opening in the center of the sensor. See Fig. 70.
2. Connect a field-supplied BLACK wire to the sensor screw terminal marked Vin.
3. Connect a field-supplied RED wire into the sensor screw terminal marked Io.
4. Connect the field-supplied RED wire from the sensor to TB3-13.
5. Connect the field-supplied BLACK wire from the sensor to TB3-7.

Humidistat connections: A humidistat can not be directly connected to the PremierLink controller. Follow the instructions on pages 22-24 to connect a humidistat or a thermostat as an electromechanical device.

SMOKE DETECTOR/FIRE SHUTDOWN (FSD) — This function is available only when the PremierLink controller is configured for (Space) Sensor Mode. The unit is factory-wired for PremierLink FSD operation when the PremierLink controller is factory-installed.

On 50HC**14 units equipped with factory-installed Smoke Detector(s), the smoke detector controller implements the unit shutdown through its NC contact set connected to the unit's CTB input. The FSD function is initiated via the smoke detector's Alarm NO contact set. The PremierLink controller communicates the smoke detector's tripped status to the CCN building control. See Fig. 58, typical PremierLink controller wiring schematic.

FILTER STATUS SWITCH — This function is available only when the PremierLink controller is configured for (Space) Sensor Mode.

PremierLink controller can monitor return filter status in two ways: By monitoring a field-supplied/installed filter pressure switch or via supply fan runtime hours.

Using switch input: — Install the dirty filter pressure switch according to switch manufacturer's instructions, to measure pressure drop across the unit's return filters. Connect one side of the switch's NO contact set to CTB's THERMOSTAT-R terminal. Connect the other side of the NO contact set to TB3-10. Setpoint for Dirty Filter is set at the switch. See Fig. 72.

Filter Switch (NO, close on rising pressure (high drop))

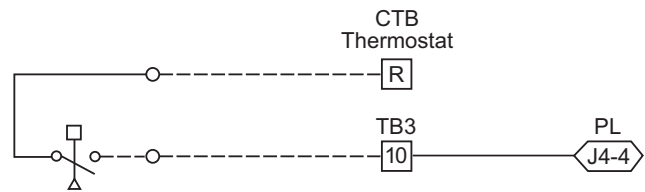

Fig. 72 — PremierLink Controller Filter Switch Connection

When the filter switch's NO contact set closes as filter pressure drop increases (indicating dirt-laden filters), the input signal to the PremierLink controller causes the filter status point to read "DIRTY."

Using Filter Timer Hours — Refer to the PremierLink Controller Installation, Start-up, and Configuration Instructions for instructions on using the PremierLink Configuration screens and on unit alarm sequence.

SUPPLY FAN STATUS SWITCH — The PremierLink controller can monitor supply fan operation through a field-supplied/installed differential pressure switch. This sequence will prevent (or interrupt) operation of unit cooling, heating and economizer functions until the pressure switch contacts are closed indicating proper supply fan operation.

Install the differential pressure switch in the supply fan section according to switch manufacturer's instructions. Arrange the switch contact to be open on no flow and to close as pressure rises indicating fan operation.

Connect one side of the switch's NO contact set to CTB's THERMOSTAT-R terminal. Connect the other side of the NO contact set to TB3-8. Setpoint for Supply Fan Status is set at the switch. See Fig. 73.

Fan (Pressure) Switch (NO, close on rise in pressure)

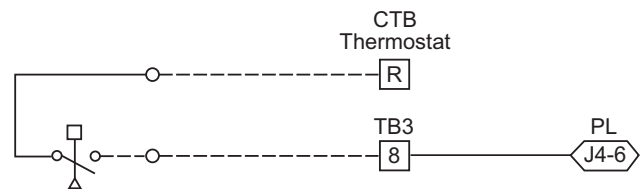

Fig. 73 — PremierLink Controller Wiring Fan Pressure Switch Connection

REMOTE OCCUPIED SWITCH — The PremierLink controller permits a remote timeclock to override the control's on-board occupancy schedule and place the unit into Occupied mode. This function may also provide a "Door Switch" time delay function that will terminate cooling and heating functions after a 2 to 20 minute delay.

Connect one side of the NO contact set on the timeclock to CTB's THERMOSTAT-R terminal. Connect the other side of the timeclock contact to the unit's TB3-2 terminal (see Fig. 74).

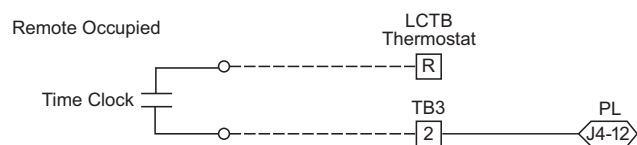

Fig. 74 — PremierLink Controller Wiring Remote Occupied

Refer to the PremierLink™ Controller Installation, Start-up, and Configuration Instructions for additional information on configuring the PremierLink controller for Door Switch timer function.

POWER EXHAUST (OUTPUT) — Connect the accessory Power Exhaust contactor coil(s) per Fig. 75.

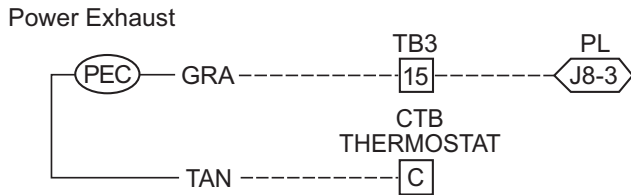

Fig. 75 — PremierLink Controller Power Exhaust Output Connection

CCN COMMUNICATION BUS — The PremierLink controller connects to the bus in a daisy chain arrangement. Negative pins on each component must be connected to respective negative pins, and likewise, positive pins on each component must be connected to respective positive pins. The controller signal pins must be wired to the signal ground pins. Wiring connections for CCN must be made at the 3-pin plug.

At any baud (9600, 19200, 38400 baud), the number of controllers is limited to 239 devices maximum. Bus length may not exceed 4000 ft, with no more than 60 total devices on any 1000-ft section. Optically isolated RS-485 repeaters are required every 1000 ft.

NOTE: Carrier device default is 9600 baud.

Communications Bus Wire Specifications — The CCN Communication Bus wiring is field-supplied and field-installed. It consists of shielded 3-conductor cable with drain (ground) wire. The cable selected must be identical to the CCN Communication Bus wire used for the entire network.

See Table 22 for recommended cable.

Table 22 — Recommended Cables

MANUFACTURER	CABLE PART NO.
Alpha	2413 or 5463
American	A22503
Belden	8772
Columbia	02525

NOTE: Conductors and drain wire must be at least 20 AWG, stranded, and tinned copper. Individual conductors must be insulated with PVC, PVC/nylon, vinyl, Teflon, or polyethylene. An aluminum/polyester 100% foil shield and an outer jacket of PVC, PVC/nylon, chrome vinyl, or Teflon with a minimum operating temperature range of -20°C to 60°C is required. Do not run communication wire in the same conduit as or next to any AC voltage wiring.

The communication bus shields must be tied together at each system element. If the communication bus is entirely within one building, the resulting continuous shield must be connected to ground at only one single point. If the communication bus cable exits from one building and enters another building, the shields must be connected to the grounds at a lightning suppressor in each building (one point only).

Connecting CCN Bus

NOTE: When connecting the communication bus cable, a color code system for the entire network is recommended to simplify installation and checkout. See Table 23 for the recommended color code.

Table 23 — Color Code Recommendations

SIGNAL TYPE	CCN BUS WIRE COLOR	CCN PLUG PIN NUMBER
+	Red	1
GROUND	White	2
-	Black	3

Connect the CCN (+) lead (typically RED) to the unit's TB3-12 terminal. Connect the CCN (ground) lead (typically WHT) to the unit's TB3-14 terminal. Connect the CCN (-) lead (typically BLK) to the unit's TB3-16 terminal. See Fig. 76.

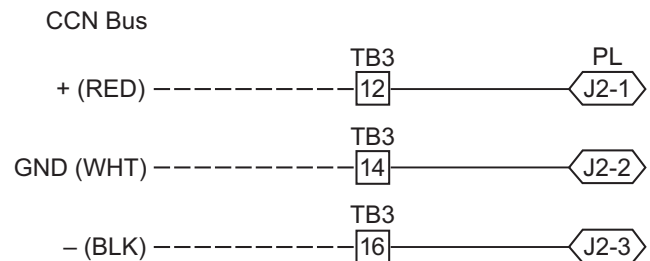

Fig. 76 — PremierLink Controller CCN Bus Connections

RTU Open Controller System — The RTU Open controller is factory-mounted in the 50HC**14 unit's main control box, to the left of the CTB. See Fig. 78. Factory wiring is completed through harnesses connected to the CTB. Field-connections for RTU Open controller sensors will be made at the Phoenix connectors on the RTU Open board. The factory-installed RTU Open controller includes the supply-air temperature (SAT) sensor. The outdoor air temperature (OAT) sensor is included in the FIOP/accessory EconoMiSer2 package.

The RTU Open controller, see Fig. 77, provides expanded stand-alone operation of the HVAC system plus connection

and control through communication with several Building Automation Systems (BAS) through popular third-party network systems. The available network systems are BACnet* MP/TP, Modbus† and Johnson N2. Communication with LonWorks** is also possible by adding an accessory interface card to the RTU Open. Selection of the communication protocol and baud rate are made at on-board DIP switches.

Refer to Table 24, RTU Open Controller Inputs and Outputs for locations of all connections to the RTU Open controller board.

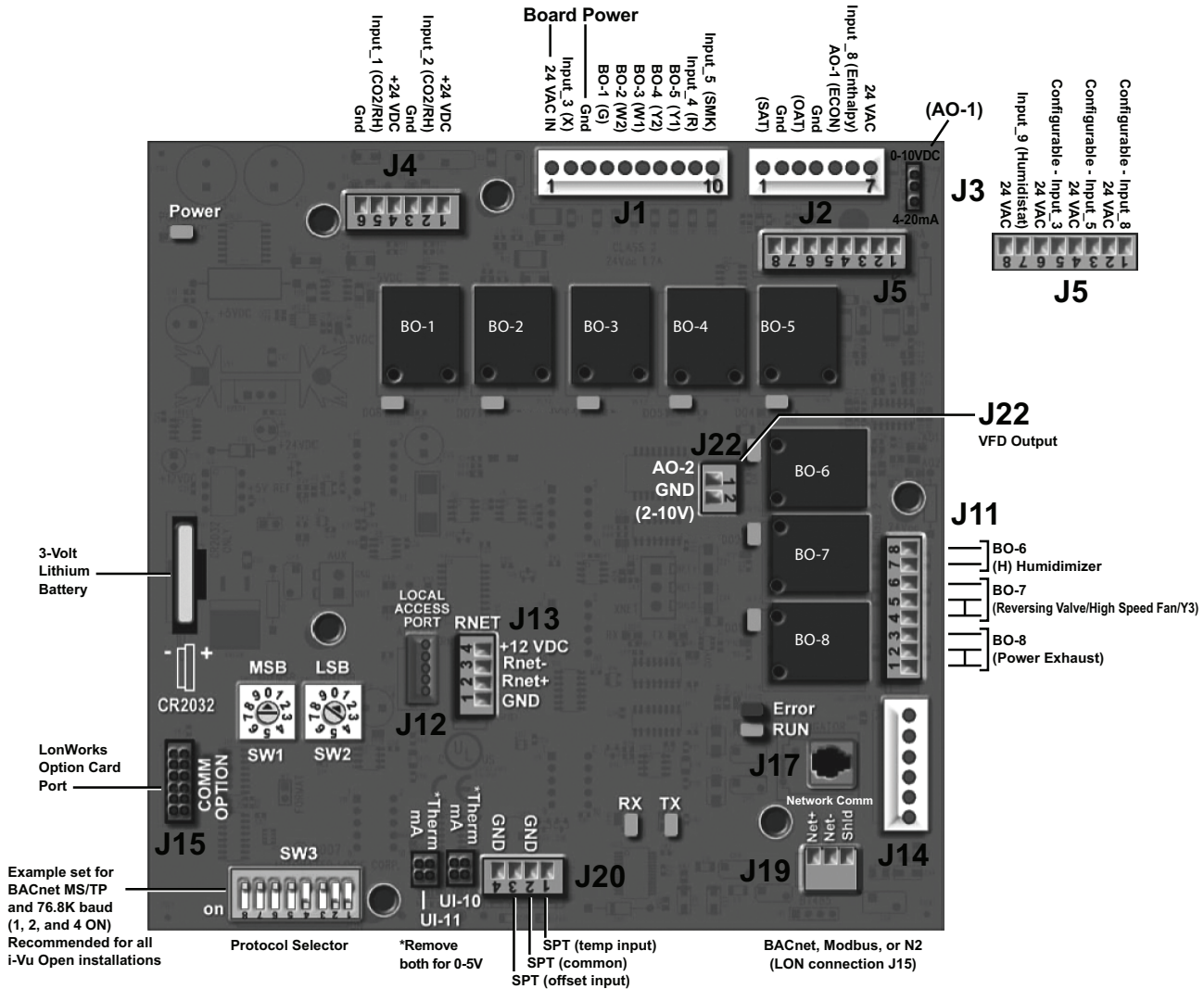

Fig. 77 — RTU Open Multi-Protocol Controller Board

* BACnet is a registered trademark of ASHRAE (American Society of Heating, Refrigerating and Air-Conditioning Engineers).
 † Modbus is a registered trademark of Schneider Electric.
 ** LonWorks is a registered trademark of Echelon Corporation.

PAC CONTROL 208/230V 460V, 575V
3 OFM DUAL COMPRESSOR

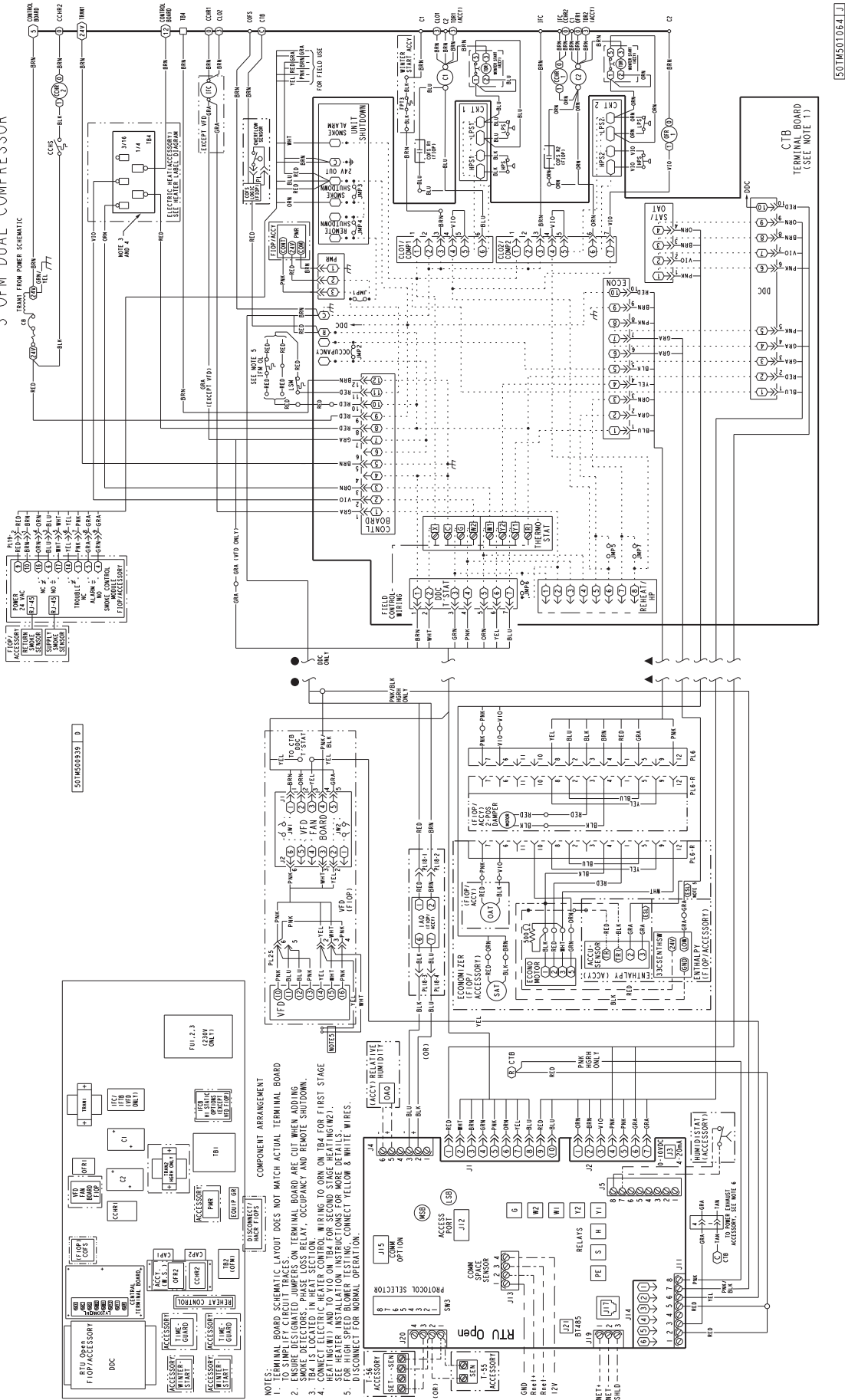

Fig. 78 — RTU Open System Control Wiring Diagram

Table 24 — RTU Open Controller Inputs and Outputs

POINT NAME	BACNET OBJECT NAME	TYPE OF I/O	CONNECTION PIN NUMBER(S)	CHANNEL DESIGNATION
DEDICATED INPUTS				
Space Temp / Zone Temp	zone_temp	AI (10K Thermistor)	J20—1 & 2	Analog Input 10
Supply Air Temperature	sa_temp	AI (10K Thermistor)	J2—1 & 2	Analog Input 6
Outside Air Temperature	oa_temp	AI (10K Thermistor)	J2—3 & 4	Analog Input 7
Space Temperature Offset Pot	stpt_adj_offset	AI (100K Potentiometer)	J20—3 & 4	Analog Input 11
Safety Chain Feedback	safety_status	BI (24 VAC)	J1—9	Binary Input 4
Compressor Safety Status (1)	comp_status	BI (24 VAC)	J1—2	Binary Input 3
Fire Shutdown Status	firedown_status	BI (24 VAC)	J1—10	Binary Input 5
Enthalpy Status	enthalpy_status	BI (24 VAC)	J2—6 & 7	Binary Input 8
Humidistat Input Status	humstat_status	BI (24 VAC)	J5—7 & 8	Binary Input 9
Zone Temperature	N/A	N/A	J13—1—4	Rnet
CONFIGURABLE INPUTS(4)				
Indoor Air CO ₂	iaq	AI (4-20 mA)	J4—2 & 3 or J4—5 & 6	Analog Input 2
Outdoor Air CO ₂	oaq	AI (4-20 mA)		Analog Input 1
Space Relative Humidity	space_rh	AI (4-20 mA)		Analog Input 10
Supply Fan Status (2)	sfan_status	BI (24 VAC)	J5—1 & 2 or J5—3 & 4, J5—5 & 6 or J5—7 & 8 (3)	Binary Input 3, 5, 8, or 9, except where intrinsic input is used
Filter Status (2)	filter_status	BI (24 VAC)		Binary Input 3, 5, 8, or 9, except where intrinsic input is used
Door Contact (2)	door_contact_status	BI (24 VAC)		Binary Input 3, 5, 8, or 9, except where intrinsic input is used
Remote Occupancy input (2)	occ_contact_status	BI (24 VAC)		Binary Input 3, 5, 8, or 9, except where intrinsic input is used
IGC input (2)	igcovr_status	BI (24 VAC)		Binary Input 9. Mandatory input on gas heat units.
OUTPUTS				
Economizer Output	econ_output	AO (4-0mA)	J2—5	Analog Output 1
Supply Fan VFD	vfd_output	AO (2-10Vdc)	J22—1 & 2	Analog Output 2
Supply Fan Relay	sfan	BO Relay (24VAC, 1A)	J1—4	Binary Output 1 (G)
Cool 1 Relay State	comp_1	BO Relay (24VAC, 1A)	J1—8	Binary Output 5 (Y1)
Cool 2 Relay State	comp_2	BO Relay (24VAC, 1A)	J1—7	Binary Output 4 (Y2)
Cool 3 Relay State	comp_3	BO Relay (24VAC, 1A)	J11—5 & 6	Binary Output 7 (Y3)
Heat 1 Relay State	heat_1	BO Relay (24VAC, 1A)	J1—6	Binary Output 3 (W1)
Heat 2 Relay State	heat_2	BO Relay (24VAC, 1A)	J1—5	Binary Output 2 (W2)
Power Exhaust Relay State	pexh	BO Relay (24VAC, 1A)	J11—2 & 3 (N.O.)	Binary Output 8 (PE)
Dehumidification Relay	dehum	BO Relay (24VAC, 1A)	J11—7 & 8 (N.O.)	Binary Output 6

LEGEND

- AI** — Analog Input
- AO** — Analog Output
- BI** — Binary Input
- BO** — Binary Output

(1) Safety Chain Feedback: 24Vac required at this terminal to provide "Run Enable" status. See Input/Output section for additional instructions.

The RTU Open controller requires the use of a Carrier space sensor. A standard thermostat cannot be used with the RTU Open system.

SUPPLY AIR TEMPERATURE (SAT) SENSOR — On FIOP-equipped 50HC**14 unit, the unit is supplied with a supply-air temperature (SAT) sensor (33ZCSENSAT). This sensor is a tubular probe type, approx 6-inches (152 mm) in length. It is a nominal 10k ohm thermistor.

The SAT is factory-wired. The SAT probe is wire-tied to the supply-air opening (on the horizontal opening end) in its shipping position. Remove the sensor for installation. Re-position the sensor in the flange of the supply-air opening or in the supply air duct (as required by local codes). Drill or punch a 1/2-in.

(2) These inputs are configurable. If installed, they take the place of the default input on the specific channel. See appropriate Input Configuration Section for wiring and setup instructions.

(3) Parallel pins J5—1 = J2—6, J5—3 = J1—10, J5—5 = J1—2 are used for field installation.

(4) Refer to the input configuration and accessory sections of the RTU Open Multi-Protocol Controller Controls, Start-Up, Operation and Troubleshooting manual for more detail.

hole in the flange or duct. Use two field-supplied, self-drilling screws to secure the sensor probe in a horizontal orientation. See Fig. 60.

OUTDOOR AIR TEMPERATURE (OAT) SENSOR — The OAT is factory-mounted in the EconoMiSer2 (FIOP or accessory). It is a nominal 10k ohm thermistor attached to an eyelet mounting ring.

ECONOMISER2 — The RTU Open controller is used with EconoMiSer2 (factory-installed option or field-installed accessory) for outdoor air management. The damper position is controlled directly by the RTU Open controller; EconoMiSer2 has no internal logic device.

Outdoor air management functions can be enhanced with field-installation of these accessory control devices:

- Enthalpy control (outdoor air or differential sensors)
- Space CO₂ sensor
- Outdoor air CO₂ sensor

Field Connections — Field connections for accessory sensors and input devices are made the RTU Open controller, at plugs J1, J2, J4, J5, J11 and J20. All field control wiring that connects to the RTU Open controller must be routed as shown in Fig. 37. The routing provides the UL required clearance between high and low-voltage wiring. Connect to the wires to the removable Phoenix connectors and then reconnect the connectors to the board.

SPACE TEMPERATURE (SPT) SENSORS — There are two types of SPT sensors available from Carrier, resistive input non-communicating (T55, T56, and T59) and Rnet communicating (SPS, SPPL, SPP, and SPPF) sensors. Each type has a variety of options consisting of: timed override button, set point adjustment, a LCD screen, and communication tie in. Space temperature can be also be written to from a building network or zoning system. However, it is still recommended that return air duct sensor be installed to allow stand-alone operation for back-up. Refer to the configuration section for details on controller configurations associated with space sensors.

Field connections to T-55, T-56 and T-59 are provided as examples.

- 33ZCT55SPT, space temperature sensor with override button (T-55)
- 33ZCT56SPT, space temperature sensor with override button and setpoint adjustment (T-56)
- 33ZCT59SPT, space temperature sensor with LCD (liquid crystal display) screen, override button, and setpoint adjustment (T-59)

Use 20 gauge wire to connect the sensor to the controller. The wire is suitable for distances of up to 500 ft. Use a three-conductor shielded cable for the sensor and setpoint adjustment connections. If the setpoint adjustment (slidebar) is not required, then an unshielded, 18 or 20 gauge, two-conductor, twisted pair cable may be used.

Connect T-55 — See Fig. 61 for typical T-55 internal connections. Connect the T-55 SEN terminals to the RTU Open controller at J20-1 and J20-2. See Fig. 80.

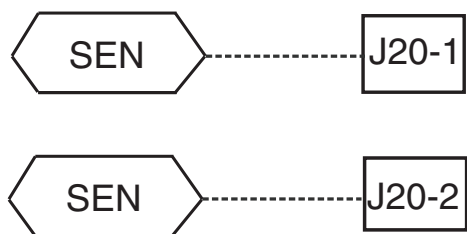

Fig. 80 — RTU Open Controller T-55 Sensor Connections

Connect T-56 — See Fig. 63 for T-56 internal connections. Install a jumper between SEN and SET terminals as illustrated. Connect T-56 terminals to the RTU Open controller at J20-1, J20-2 and J20-3 per Fig. 81.

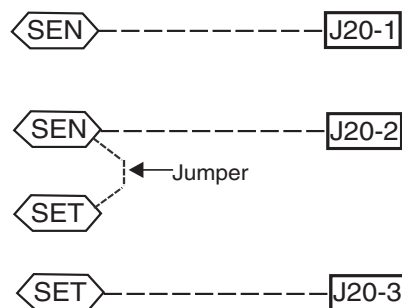
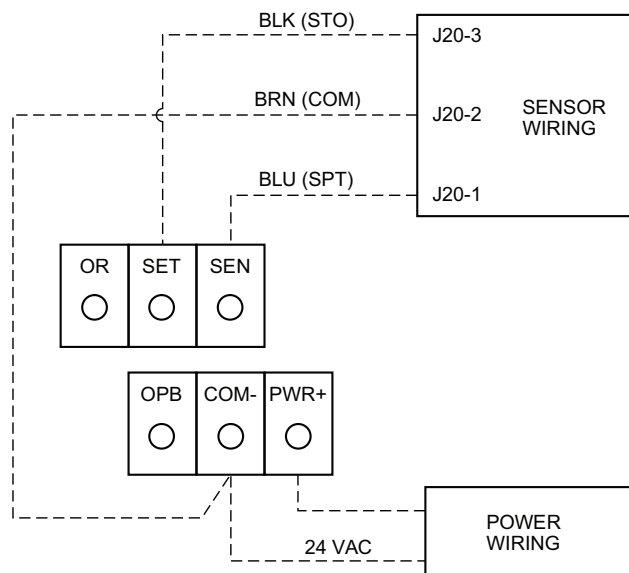

Fig. 81 — RTU Open Controller T-56 Sensor Connections

Connect T-59 — The T-59 space sensor requires a separate, isolated power supply of 24 VAC. See Fig. 82 for internal connections at the T-59. Connect the SEN terminal (BLU) to the RTU Open controller at J20-1. Connect the COM terminal (BRN) to J20-2. Connect the SET terminal (STO or BLK) to J20-3.



NOTE: Must use a separate isolated transformer.

Fig. 82 — Space Temperature Sensor Typical Wiring (33ZCT59SPT)

INDOOR AIR QUALITY (CO₂) SENSOR — The indoor air quality sensor accessory monitors space carbon dioxide (CO₂) levels. This information is used to monitor IAQ levels. Several types of sensors are available, for wall mounting in the space or in return duct, with and without LCD display, and in combination with space temperature sensors. Sensors use infrared technology to measure the levels of CO₂ present in the space air.

The CO₂ sensors are all factory set for a range of 0 to 2000 ppm and a linear mA output of 4 to 20. Refer to the instructions supplied with the CO₂ sensor for electrical requirements and terminal locations. See Fig. 66 for typical CO₂ sensor wiring schematic.

To accurately monitor the quality of the air in the conditioned air space, locate the sensor near a return-air grille (if present) so it senses the concentration of CO₂ leaving the space. The sensor should be mounted in a location to avoid direct breath contact.

Do not mount the IAQ sensor in drafty areas such as near supply ducts, open windows, fans, or over heat sources. Allow at least 3 ft (0.9 m) between the sensor and any corner. Avoid mounting the sensor where it is influenced by the supply air; the sensor gives inaccurate readings if the supply air is blown directly onto the sensor or if the supply air does not have a chance to mix with the room air before it is drawn into the return airstream.

Wiring the Indoor Air Quality Sensor — For each sensor, use two 2-conductor 18 AWG (American Wire Gauge) twisted-pair cables (unshielded) to connect the separate isolated 24 vac power source to the sensor and to connect the sensor to the control board terminals.

To connect the sensor to the control, identify the positive (4 to 20 mA) and ground (SIG COM) terminals on the sensor. See Fig. 66. Connect the 4-20 mA terminal to the RTU Open controller at J4-2 and connect the SIG COM terminal to the RTU Open controller at J4-3. See Fig. 83.

IAQ Sensor

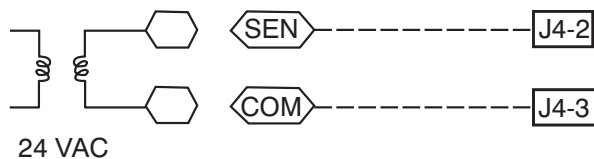

Fig. 83 — RTU Open Controller/Indoor CO₂ Sensor (33ZCSENCO2) Connections

OUTDOOR AIR QUALITY SENSOR (P/N 33ZCSENCO2 PLUS WEATHERPROOF ENCLOSURE) — The outdoor air CO₂ sensor is designed to monitor carbon dioxide (CO₂) levels in the outside ventilation air and interface with the ventilation damper in an HVAC system. The OAQ sensor is packaged with an outdoor cover. See Fig. 68. The outdoor air CO₂ sensor must be located in the economizer outside air hood.

Wiring the Outdoor Air CO₂ Sensor — A dedicated power supply is required for this sensor. A two-wire cable is required to wire the dedicated power supply for the sensor. The two wires should be connected to the power supply and terminals 1 and 2.

To connect the sensor to the control, identify the positive (4 to 20 mA) and ground (SIG COM) terminals on the OAQ sensor. See Fig. 66. Connect the 4 to 20 mA terminal to the RTU Open controller at J4-5. Connect the SIG COM terminal to the RTU Open controller at J4-6. See Fig. 84.

OAQ Sensor/RH Sensor

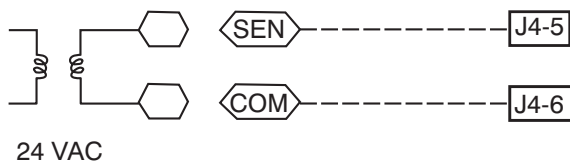

Fig. 84 — RTU Open Controller/Outdoor CO₂ Sensor (33ZCSENCO2) Connections

SPACE RELATIVE HUMIDITY SENSOR OR HUMIDISTAT

Humidi-MiZer® System Control Wiring — In units equipped with the Humidi-MiZer option there are two pink (PNK) wires loose in the control box used to control the dehumidification function of the unit. These pink wires are meant to be tied to a space humidistat or thermidstat on an electromechanical unit. On RTU Open controller equipped units these pink wires must be connected to J11-7 and 8 to allow the Open board to operate the dehumidification function for the unit. Disconnect the J11 Phoenix style connector from the board and use the plug screws to secure the pink wires in pins 7 and 8, reconnect the plug to the board at J11.

Relative Humidity Sensors (Space or Duct Mounted) — The accessory space humidity sensor (33ZCSENSRH-01) or duct humidity sensor (33ZCSENDRH-01) is used to measure the relative humidity of air within the space or return air duct. The RH reading is used to control the Humidi-MiZer option of the rooftop unit. For wiring distances up to 500 ft (152 m), use a 3-conductor, 18 or 20 AWG shielded cable. The shield must be removed from the sensor end of the cable and grounded at the unit end. The current loop power for sensor is provided by the RTU Open controller as 24vdc. Refer to the instructions supplied with the RH sensor for the electrical requirements and terminal locations. RTU Open controller configurations must be changed after adding an RH sensor. See Fig. 85 and 86 for typical RH sensor wiring.

- J4-1 or J4-4 = 24vdc loop power
- J4-2 or J4-5 = 4-20mA signal input

NOTE: The factory default for dehumidification control is normally open humidistat.

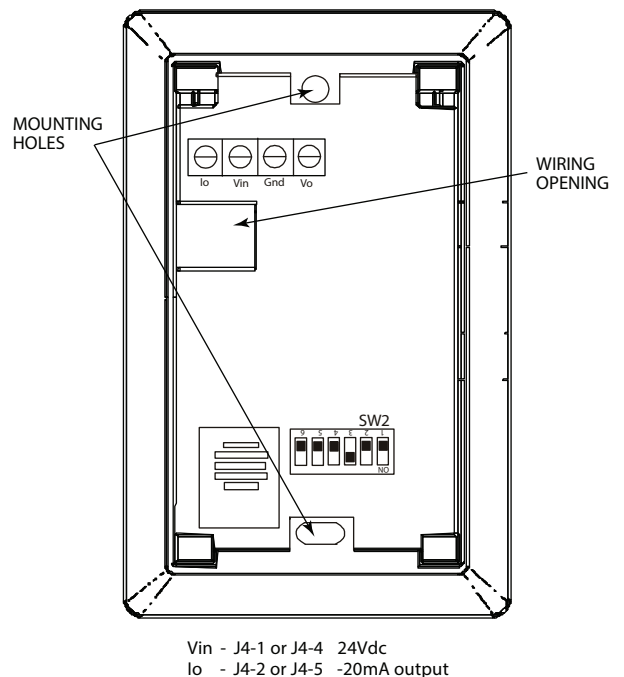

Fig. 85 — Space Relative Humidity Sensor Typical Wiring

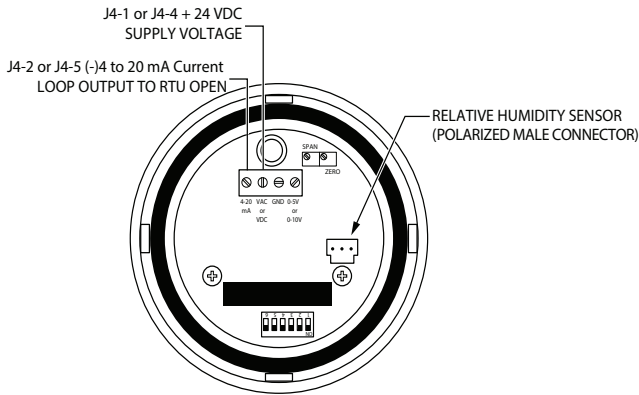

Fig. 86 — Duct Relative Humidity Sensor Typical Wiring

Humidistat — The accessory humidistat provides the RTU Open controller insight to the relative humidity in the space. The humidistat reads the RH level in the space and compares it to its setpoint to operate a dry contact. The humidistat is a dedicated input on the configurable input 9 and tells the RTU Open controller when the RH level is HIGH or LOW. The normal condition for humidity is LOW. A normally open humidistat is the factory default control for the Humidi-MiZer system option.

To wire in the field:

- J5—8 = 24 VAC source for dry contact
- J5—7 = Signal input

SMOKE DETECTOR/FIRE SHUTDOWN (FSD) — On 50HC**14 units equipped with factory-installed Smoke Detector(s), the smoke detector controller implements the unit shutdown through its NC contact set connected to the unit's CTB input. The FSD function is initiated via the smoke detector's Alarm NO contact set. The RTU Open controller communicates the smoke detector's tripped status to the BAS building control. See Fig. 78, (RTU Open Controller wiring diagrams).

The Fire Shutdown Switch configuration, **MENU**→**Config**→**Inputs**→**input 5**, identifies the normally open status of this input when there is no fire alarm.

CONNECTING DISCRETE INPUTS

Filter Status — The filter status accessory is a field-installed accessory. This accessory detects plugged filters. When installing this accessory, the unit must be configured for filter status by setting **MENU**→**Config**→**Inputs**→**input 3, 5, 8, or 9** to Filter Status and normally open (N/O) or normally closed (N/C). Input 8 or 9 is recommended for ease of installation. Refer to Fig. 77 and Fig. 78 or 79 for wire terminations at J5.

Fan Status — The fan status accessory is a field-installed accessory. This accessory detects when the indoor fan is blowing air. When installing this accessory, the unit must be configured for fan status by setting **MENU**→**Config**→**Inputs**→**input 3, 5, 8, or 9** to Fan Status and normally open (N/O) or normally closed (N/C). Input 8 or 9 is recommended for ease of installation. Refer to Fig. 77 and Fig. 78 or 79 for wire terminations at J5.

Remote Occupancy — The remote occupancy accessory is a field-installed accessory. This accessory overrides the unoccupied mode and puts the unit in occupied mode. When installing this accessory, the unit must be configured for remote occupancy by setting **MENU**→**Config**→**Inputs**→**input 3, 5, 8, or 9** to Remote Occupancy and normally open (N/O) or normally closed (N/C).

Also set **MENU**→**Schedules**→**occupancy source** to DI on/off. Input 8 or 9 is recommended for ease of installation. Refer to Fig. 77 and Table 24 for wire terminations at J5.

Power Exhaust (output) — The relay used by the RTU Open controller board to control power exhaust is a dry contact which means it does not have 24vac. This 24vac must be connected to the relay to allow it to operate the power exhaust relay in the PE accessory. A 24vac source must be provided to J11-2 on the RTU Open controller board. This can be provided by the unit's transformer from various sources. The "R" terminal on the unit's central terminal board (CTB) is a logical source. Refer to Fig. 77 and Fig. 78 or 79 for wire terminations at J11.

Communication Wiring — Protocols

GENERAL — Protocols are the communication languages spoken by control devices. The main purpose of a protocol is to communicate information in the most efficient method possible. Different protocols exist to provide different kinds of information for different applications. In the BAS application, many different protocols are used, depending on manufacturer. Protocols do not change the function of a controller; just make the front end user different.

The RTU Open controller can be set to communicate on four different protocols: BACnet, Modbus, N2, and LonWorks. Switch 3 (SW3) on the board is used to set protocol and baud rate. Switches 1 and 2 (SW1 and SW2) are used to set the board's network address. See Fig. 87 and 88 for protocol switch settings and address switches. The third party connection to the RTU Open controller is through plug J19. See Fig. 89 for wiring.

NOTE: Power must be cycled after changing the SW1-3 switch settings.

Refer to the RTU Open Controller Integration Guide for more detailed information on protocols, third party wiring, and networking.

SW3 Protocol Selection

PROTOCOL	DS8	DS7	DS6	DS5	DS4	DS3	DS2	DS1
BACnet MS/TP (Master)	Unused	OFF	OFF	OFF	ON	OFF	Select Baud	Select Baud
Modbus (Slave)	Unused	OFF	OFF	ON	ON	OFF	Select Baud	Select Baud
N2 (Slave)	Unused	OFF	OFF	OFF	ON	ON	OFF	OFF
LonWorks	Unused	ON	ON	OFF	ON	OFF	OFF	ON

NOTE:
DS = Dip Switch
BACnet MS/TP SW3 example shown

Baud Rate Selections

BAUD RATE	DS2	DS1
9600	OFF	OFF
19,200	ON	OFF
38,400	OFF	ON
76,800	ON	ON

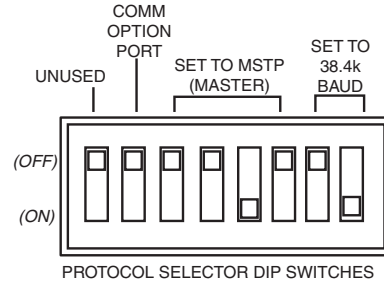

Fig. 87 — RTU Open Controller SW3 Dip Switch Settings

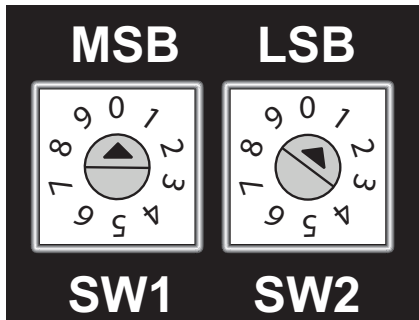

Fig. 88 — RTU Open Controller Address Switches

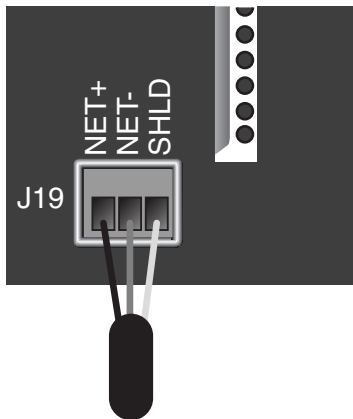

Fig. 89 — Network Wiring

Local Access

WALL MOUNTED EQUIPMENT TOUCH INTERFACE — The Equipment Touch interface is a wall mounted interface used to connect to the RTU Open controller to access the control information, read sensor values, and maintenance. This is an accessory interface that does not come with the RTU Open controller. You wire the Equipment Touch interface to the RTU Open controller's J13 local access port. There are 2 password protected levels in the display (User and Admin). See the Equipment Touch Installation and Setup Guide for more information. See Appendix A for navigation and screen content.

FIELD ASSISTANT — Field Assistant is a computer program included with the purchase of the Tech Tool Kit (USB-TKIT). This is a field Tech Tool to set-up, service, or download application software to the RTU Open controller and includes a USB Link Cable. The link cable connects a USB port to the J12 local access port. The Field Assistant's menu structure is similar and functions the same as i-Vu® controller. See Fig. 90.

RTU OPEN CONTROLLER TROUBLESHOOTING

Communication LEDs — The LEDs indicate if the controller is speaking to the devices on the network. The LEDs should reflect communication traffic based on the baud rate set. The higher the baud rate the more solid the LEDs will appear. See Table 25.

NOTE: Refer to the RTU Open Multi-Protocol Controller Controls, Start-Up, Operation and Troubleshooting manual for complete configuration of the RTU Open controller, operating sequences and troubleshooting information. Refer to the RTU Open v3 Integration Guide for details on configuration and troubleshooting of connected networks. Have a copy of these manuals available at unit start-up.

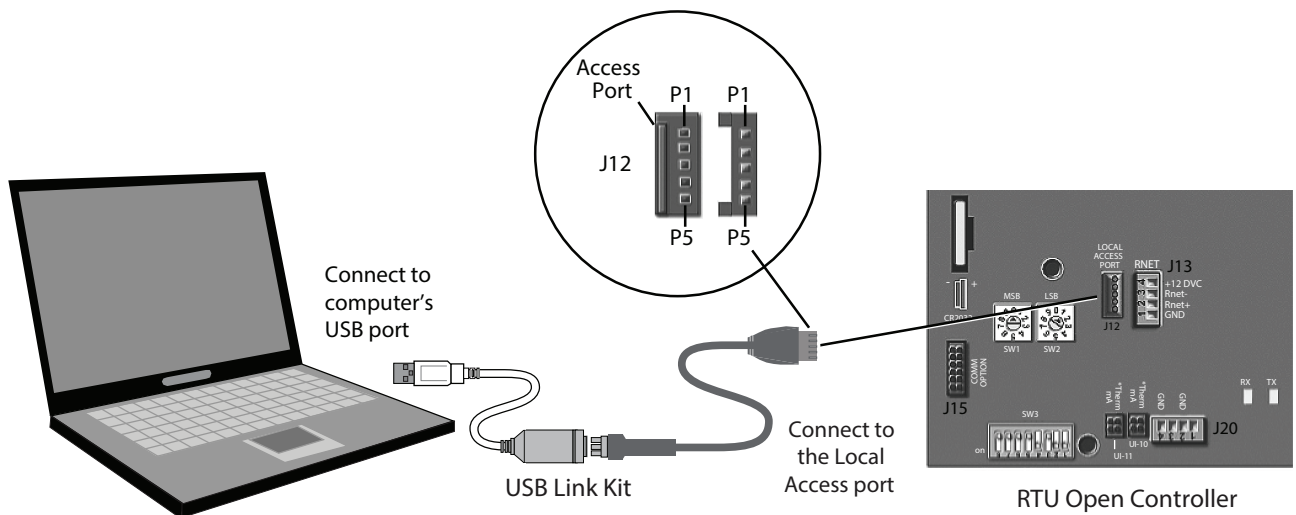

Fig. 90 — PC Running Field Assistant

Table 25 — LEDs

The LEDs on the RTU Open Control Board (see Fig. 77) show the status of certain functions

If this LED is on...	Status is...
Power	The RTU Open controller has power
Rx	The RTU Open controller is receiving data from the network segment
Tx	The RTU Open controller is transmitting data over the network segment
BO#	The binary output is active

The **Run** and **Error** LEDs indicate control module and network status

If Run LED shows...	And Error LED shows...	Status is...
2 flashes per second	Off	Normal
2 flashes per second	2 flashes, alternating with Run LED	Five minute auto-restart delay after system error
2 flashes per second	3 flashes, then off	Control module has just been formatted
2 flashes per second	4 flashes, then pause	Two or more devices on this network have the same MSTP network address
2 flashes per second	On	Exec halted after frequent system errors or control programs halted
5 flashes per second	On	Exec start-up aborted, Boot is running
5 flashes per second	Off	Firmware transfer in progress, Boot is running
7 flashes per second	7 flashes per second, alternating with Run LED	Ten second recovery period after brownout
14 flashes per second	14 flashes per second, alternating with Run LED	Brownout
On	On	Failure. Try the following solutions: <ul style="list-style-type: none"> · Turn the RTU Open controller off, then on. · Format the RTU Open controller. · Download memory to the RTU Open controller. · Replace the RTU Open controller.

Outdoor Air Enthalpy Control (P/N 33CSENTHSW) — The enthalpy control (33CSENTHSW) is available as a field-installed accessory to be used with the EconoMiSer2 damper system. The outdoor air enthalpy sensor is part of the enthalpy control. (The separate field-installed accessory return air enthalpy sensor (33CSENSEN) is required for differential enthalpy control. See Fig. 91.)

Locate the enthalpy control in the economizer next to the Actuator Motor. Locate two GRA leads in the factory harness and connect the gray lead labeled “ESL” to the terminal labeled “LOW.” See Fig. 92. Connect the enthalpy control power input terminals to economizer actuator power leads RED (connect to 24V) and BLK (connect to GND).

The outdoor enthalpy changeover setpoint is set at the enthalpy controller.

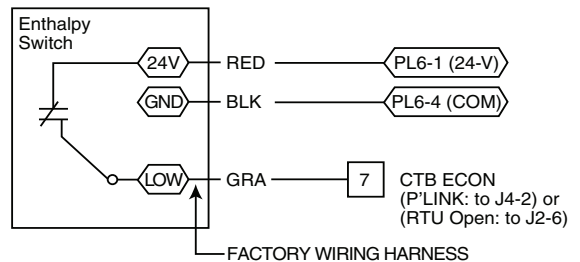

Fig. 91 — Enthalpy Switch (33CSENTHSW) Connections

DIFFERENTIAL ENTHALPY CONTROL — Differential enthalpy control is provided by sensing and comparing the outside air and return air enthalpy conditions. Install the outdoor air enthalpy control as described above. Add and install a return air enthalpy sensor.

RETURN AIR ENTHALPY SENSOR — Mount the return-air enthalpy sensor (33CENTSEN) in the return-air section of the economizer. The return air sensor is wired to the enthalpy controller (33CENTHSW). See Fig. 92.

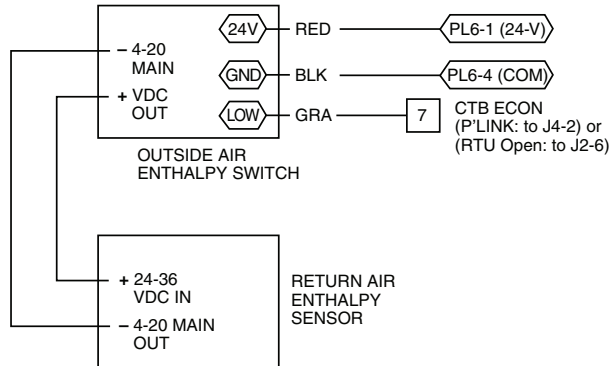

Fig. 92 — Outside and Return Air Enthalpy Sensor Wiring

To wire the return air enthalpy sensor, perform the following:

1. Use a 2-conductor, 18 or 20 AWG, twisted pair cable to connect the return air enthalpy sensor to the enthalpy controller.
2. Connect the field-supplied RED wire to (+) spade connector on the return air enthalpy sensor and the (+) terminal on the enthalpy controller. Connect the BLK wire to (-) spade connector on the return air enthalpy sensor and the (-) terminal on the enthalpy controller.

Smoke Detectors — Smoke detectors are available as factory-installed options on 50HC**14 models. Smoke detectors may be specified for Supply Air only or for Return Air without or with economizer or in combination of Supply Air and Return Air. Return Air smoke detectors are arranged for vertical return configurations only. All components necessary for operation are factory-provided and mounted. The unit is factory-configured for immediate smoke detector shutdown operation; additional wiring or modifications to unit terminal

board may be necessary to complete the unit and smoke detector configuration to meet project requirements.

Units equipped with factory-optional Return Air smoke detectors require a relocation of the sensor module at unit installation. See Fig. 93 for the as shipped location.

Completing Installation of Return Air Smoke Sensor:

1. Unscrew the two screws holding the Return Air Smoke Detector assembly. See Fig. 94, Step 1. Save the screws.
2. Turn the assembly 90 and then rotate end to end. Make sure that the elbow fitting is pointing down. See Fig. 94, Step 2.
3. Screw the sensor and detector plate into its operating position using screws from Step 1. See Fig. 94, Step 3.
4. Connect the flexible tube on the sampling inlet to the sampling tube on the basepan.

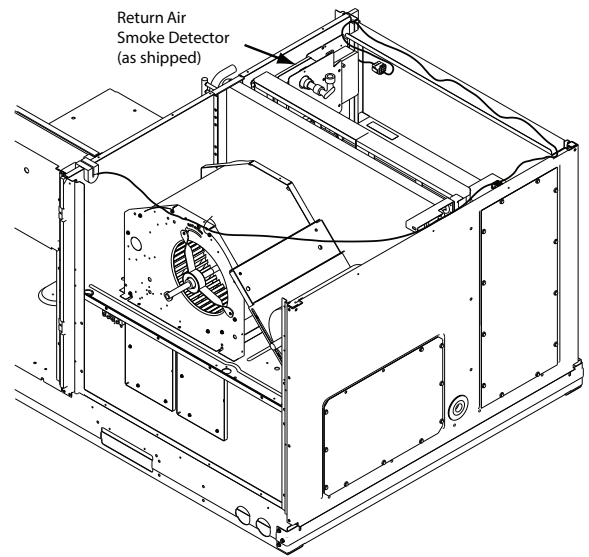

Fig. 93 — Return Air Smoke Detector, Shipping Position

ADDITIONAL APPLICATION DATA — Refer to the Application Data sheet titled Factory Installed Smoke Detectors for Small and Medium Rooftop Units 2 to 25 Tons for discussions on additional control features of these smoke detectors including multiple unit coordination.

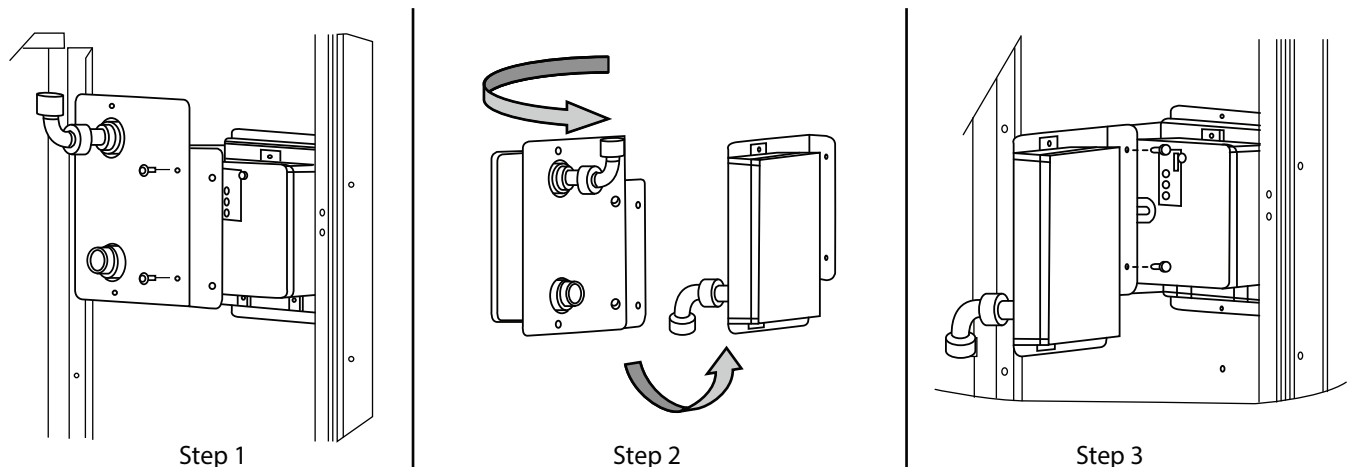

Fig. 94 — Completing Installation of Return Air Smoke Sensor

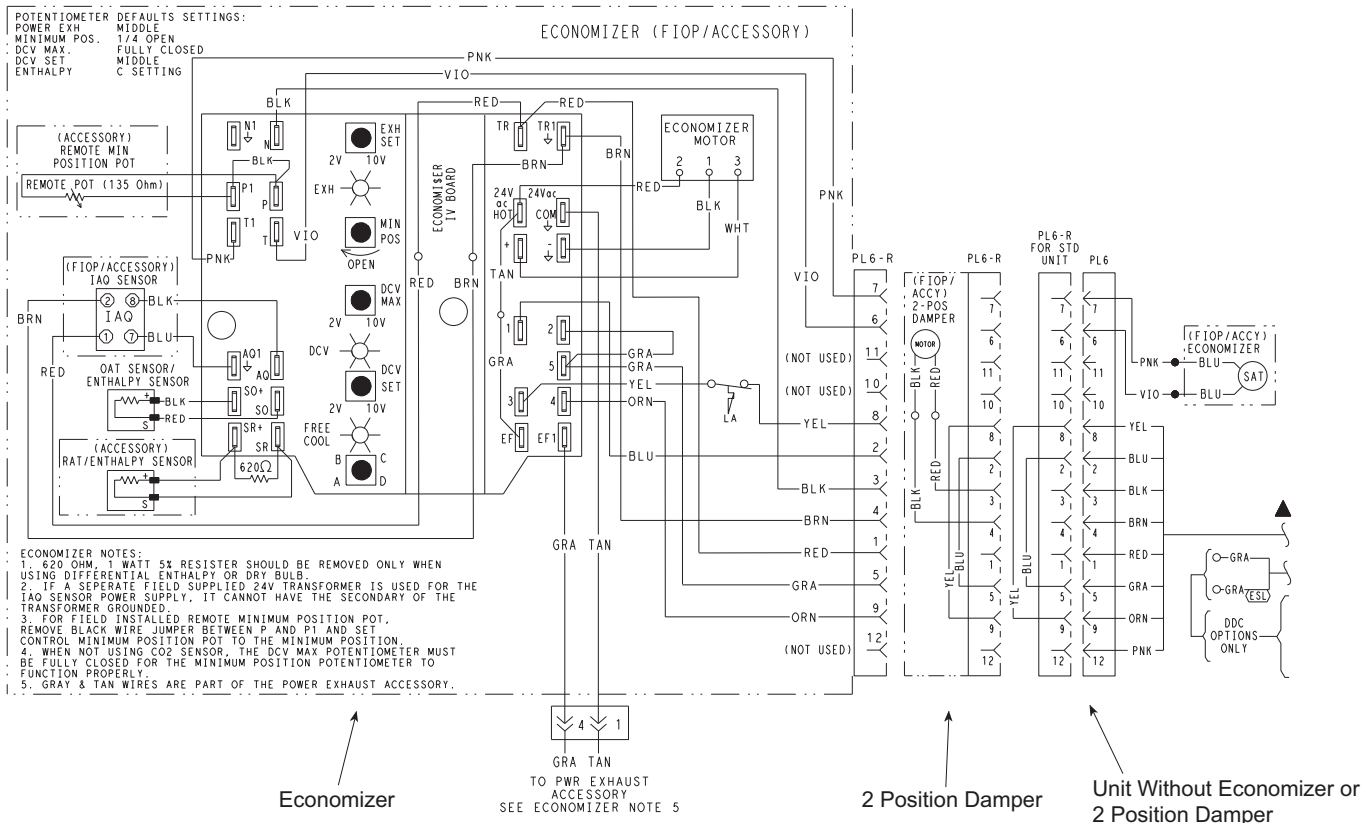

Fig. 95 — EconoMiSer® IV Wiring

Step 11 — Adjust Factory-Installed Options

SMOKE DETECTORS — Smoke detector(s) will be connected at the Controls Connections Board, at terminals marked “Smoke Shutdown.” Cut jumper JMP 3 when ready to energize unit.

ECONOMISER IV OCCUPANCY SWITCH — Refer to Fig. 95 for general EconoMiSer IV wiring. External occupancy control is managed through a connection on the Controls Connections Board.

If external occupancy control is desired, connect a time clock or remotely controlled switch (closed for Occupied, open for Unoccupied sequence) at terminals marked OCCUPANCY. Cut jumper JMP 2 to complete the installation.

Step 12 — Install Accessories — Available accessories include:

- Roof Curb (must be installed before unit)
- Thru-base connection kit (must be installed before unit is set on curb)
- Manual outside air damper
- Two-Position motorized outside air damper
- EconoMiSer IV (with control and integrated barometric relief)
- EconoMiSer2 (without control/for external signal and integrated barometric relief)
- Barometric relief
- Power Exhaust
- Differential dry-bulb sensor (EconoMiSer IV)
- Outdoor enthalpy sensor
- Differential enthalpy sensor
- Time Guard II compressor anti-cycle control
- Outdoor coil protector grille

- Head pressure control
- Programmable setback thermostat
- Electrical/Mechanical thermostat and subbase
- Thermidistat device
- Humidistat
- Thermostat / Sensors
- CO₂ sensor
- DDC interface (PremierLink controller)
- Louvered hail guard
- Phase monitor control

Refer to separate installation instructions for information on installing these accessories.

Pre-Start and Start-Up — This completes the mechanical installation of the unit. Refer to the unit’s Service Manual for detailed Pre-Start and Start-Up instructions. Download the latest versions from HVAC Partners (www.hvacpartners.com).

START-UP CHECKLIST
(Remove and use for job file)

NOTE: To avoid injury to personnel and damage to equipment or property when completing the procedures listed in this start-up checklist, use good judgment, follow safe practices, and adhere to the safety considerations/information as outlined in preceding sections of this Installation Instructions document.

MODEL NO.: _____ SERIAL NO.: _____

I. PRE-START-UP

- VERIFY THAT ALL PACKAGING MATERIALS HAVE BEEN REMOVED FROM UNIT
- VERIFY INSTALLATION OF OUTDOOR AIR HOOD
- VERIFY INSTALLATION OF FLUE EXHAUST AND INLET HOOD
- VERIFY THAT CONDENSATE CONNECTION IS INSTALLED PER INSTRUCTIONS
- VERIFY THAT ALL ELECTRICAL CONNECTIONS AND TERMINALS ARE TIGHT
- CHECK THAT INDOOR-AIR FILTERS ARE CLEAN AND IN PLACE
- CHECK THAT OUTDOOR AIR INLET SCREENS ARE IN PLACE
- VERIFY THAT UNIT IS LEVEL
- CHECK FAN WHEELS AND PROPELLER FOR LOCATION IN HOUSING/ORIFICE AND VERIFY SETSCREW IS TIGHT
- VERIFY THAT FAN SHEAVES ARE ALIGNED AND BELTS ARE PROPERLY TENSIONED
- VERIFY THAT SCROLL COMPRESSORS ARE ROTATING IN THE CORRECT DIRECTION
- VERIFY INSTALLATION OF THERMOSTAT

II. START-UP

ELECTRICAL

SUPPLY VOLTAGE	L1-L2 _____	L2-L3 _____	L3-L1 _____
COMPRESSOR AMPS 1	L1 _____	L2 _____	L3 _____
COMPRESSOR AMPS 2	L1 _____	L2 _____	L3 _____
SUPPLY FAN AMPS	L1 _____	L2 _____	L3 _____

TEMPERATURES

OUTDOOR-AIR TEMPERATURE	_____ °F DB (DRY BULB)	
RETURN-AIR TEMPERATURE	_____ °F DB	_____ °F WB (WET BULB)
COOLING SUPPLY AIR TEMPERATURE	_____ °F	

PRESSURES

REFRIGERANT SUCTION	CIRCUIT A	_____ PSIG
	CIRCUIT B	_____ PSIG
REFRIGERANT DISCHARGE	CIRCUIT A	_____ PSIG
	CIRCUIT B	_____ PSIG

- VERIFY REFRIGERANT CHARGE USING CHARGING CHARTS

GENERAL

- ECONOMIZER MINIMUM VENT AND CHANGEOVER SETTINGS TO JOB REQUIREMENTS (IF EQUIPPED)
- VERIFY SMOKE DETECTOR UNIT SHUTDOWN BY UTILIZING MAGNET TEST

III. HUMIDI-MIZER SYSTEM START-UP

STEPS

- 1. CHECK CTB FOR JUMPER 5, 6, 7
JUMPER 5, 6, 7 MUST BE CUT AND OPEN
 - 2. OPEN HUMIDISTAT CONTACTS
 - 3. START UNIT IN COOLING (CLOSE Y1)
OBSERVE AND RECORD
 - A. SUCTION PRESSURE _____ PSIG
 - B. DISCHARGE PRESSURE _____ PSIG
 - C. ENTERING AIR TEMPERATURE _____ °F
 - D. LIQUID LINE TEMPERATURE
AT OUTLET OR REHEAT COIL _____ °F
 - E. CONFIRM CORRECT ROTATION FOR COMPRESSOR
 - F. CHECK FOR CORRECT RAMP-UP OF OUTDOOR FAN MOTOR AS CONDENSER COIL WARMS
 - 4. CHECK UNIT CHARGE PER CHARGING CHART
 - 5. SWITCH UNIT TO HIGH-LATENT MODE (SUBCOOLER) BY CLOSING HUMIDISTAT WITH Y1 CLOSED
OBSERVE
 - A. REDUCTION IN SUCTION PRESSURE (5 TO 7 PSI EXPECTED)
 - B. DISCHARGE PRESSURE UNCHANGED
 - C. LIQUID TEMPERATURE DROPS TO 50 TO 55°F RANGE
 - D. LIQUID SOLENOID VALVE (LSV) ENERGIZED (VALVE CLOSES)
 - 6. SWITCH UNIT TO DEHUMID (REHEAT) BY OPENING Y1
OBSERVE
 - A. SUCTION PRESSURE INCREASES TO NORMAL COOLING LEVEL
 - B. DISCHARGE PRESSURE DECREASES (35 TO 50 PSI)
 - C. LIQUID TEMPERATURE RETURNS TO NORMAL COOLING LEVEL
 - D. LIQUID SOLENOID VALVE (LSV) ENERGIZED (VALVE CLOSES)
 - E. DISCHARGE SOLENOID VALVE (DSV) ENERGIZED, VALVE OPENS
 - 7. WITH UNIT IN DEHUMID MODE CLOSE W1
COMPRESSOR AND OUTDOOR FAN STOP; LSV AND DSV SOLENOIDS DE-ENERGIZED
 - 8. OPEN W1 RESTORE UNIT TO DEHUMID MODE
 - 9. OPEN HUMIDISTAT INPUT
COMPRESSOR AND OUTDOOR FAN STOP; LSV AND DSV SOLENOIDS DE-ENERGIZED
 - 10. RESTORE SETPOINTS FOR THERMOSTAT AND HUMIDISTAT
- REPEAT PROCESS FOR 2 COMPRESSOR SYSTEMS**

CUT ALONG DOTTED LINE

CUT ALONG DOTTED LINE