

50HCQD12
WeatherMaster® Series
Single Package Rooftop
Heat Pump
with Puron® (R-410A) Refrigerant
Size 12



Installation Instructions

NOTE: Read the entire instruction manual before starting the installation.

TABLE OF CONTENTS

| | | | |
|--|----|---|----|
| SAFETY CONSIDERATIONS | 2 | Thermostat | 20 |
| Rated Indoor Airflow (cfm) | 3 | Central Terminal Board | 21 |
| REFRIGERATION SYSTEM COMPONENTS | 6 | Commercial Defrost Board | 21 |
| INSTALLATION | 8 | Unit Without Thru-Base Conversion Kit | 23 |
| Jobsite Survey | 8 | Heat Anticipator Settings | 23 |
| Step 1 - Plan for Unit Location | 8 | Electric Heaters | 23 |
| Roof Mount | 8 | Single Point Boxes | 24 |
| Step 2 - Plan for Sequence of Unit Installation | 8 | Heater and Supplementary Fuses | 24 |
| Curb-Mount Installation | 8 | Heater Low-Voltage Control Connections | 24 |
| Pad-Mount Installation | 8 | EconoMi\$er® X (Factory-Installed Option) | 25 |
| Frame-Mount Installation | 8 | Product Description | 25 |
| Step 3 - Inspect Unit | 8 | System Components | 25 |
| Step 4 - Provide Unit Support | 8 | Specifications | 25 |
| Roof Curb Mount | 8 | W7220 Economizer Module | 25 |
| Slab Mount (Horizontal Units Only) | 10 | Electrical | 26 |
| Alternate Unit Support | 10 | Inputs | 26 |
| Step 5 - Field Fabricate Ductwork | 10 | Outputs | 26 |
| For Units with Accessory Electric Heaters | 10 | Environmental | 26 |
| Step 6 - Rig and Place Unit | 10 | Economizer Module Wiring Details | 26 |
| Positioning on Curb | 11 | S-Bus Sensor Wiring | 27 |
| Step 7 - Convert to Horizontal and Connect Ductwork .. | 11 | CO ₂ Sensor Wiring | 27 |
| Step 8 - Install Outside Air Hood | 11 | Interface Overview | 28 |
| Economizer Hood Removal and Setup | 11 | User Interface | 28 |
| Two Position Damper Hood Removal and Setup .. | 12 | Keypad | 28 |
| Economizer Hood and Two-Position Hood | 12 | Menu Structure | 28 |
| Step 9 - Install External Condensate Trap and Line ... | 13 | Setup and Configuration | 28 |
| Step 10 - Make Electrical Connections | 13 | Time-out and Screensaver | 28 |
| Field Power Supply | 14 | Sequence of Operation | 35 |
| All Units | 15 | Enthalpy Settings | 37 |
| Units Without Factory-Installed | | Two-Speed Fan Operation | 38 |
| Non-Fused Disconnect | 18 | Checkout | 38 |
| Units with Factory-Installed | | Power Up | 39 |
| Non-Fused Disconnect | 18 | Initial Menu Display | 39 |
| Convenience Outlets | 18 | Power Loss (Outage or Brownout) | 39 |
| Factory-Option Thru-Base Connections | 20 | Status | 39 |
| Units Without Thru-Base Connections | 20 | Checkout Tests | 39 |
| Field Control Wiring | 20 | Troubleshooting | 39 |
| | | Alarms | 39 |
| | | Clearing Alarms | 39 |

| | |
|---|----|
| Staged Air Volume (SAV™) with Variable Frequency Drive (Factory-Installed Option) | 39 |
| PremierLink™ Controller (Factory-Installed Option) | 40 |
| Supply Air Temperature (SAT) Sensor | 40 |
| Outdoor Air Temperature (OAT) Sensor | 42 |
| EconoMi\$er® 2 | 42 |
| Field Connections | 42 |
| Space Sensors | 42 |
| Connect Thermostat | 42 |
| Configure the Unit for Thermostat Mode | 43 |
| Economizer Controls | 45 |
| Indoor Air Quality (CO ₂ sensor) | 45 |
| Outdoor Air Quality Sensor | 45 |
| Smoke Detector/Fire Shutdown (FSD) | 46 |
| Filter Status Switch | 46 |
| Supply Fan Status Switch | 46 |
| Remote Occupied Switch | 46 |
| Space Relative Humidity Sensor | 46 |
| Power Exhaust (output) | 46 |
| CCN Communication Bus | 47 |
| RTU Open Controller System | 48 |
| Supply Air Temperature (SAT) Sensor | 50 |
| Outdoor Air Temperature (OAT) Sensor | 50 |
| EconoMi\$er 2 | 50 |
| Field Connections | 50 |
| Space Temperature (SPT) Sensors | 51 |
| Indoor Air Quality (CO ₂) Sensor | 51 |
| Outdoor Air Quality Sensor | 52 |
| Space Relative Humidity Sensor | 52 |
| Smoke Detector/Fire Shutdown (FSD) | 52 |
| Connecting Discrete Inputs | 52 |
| Communication Wiring - Protocols | 52 |
| General | 52 |
| Local Access | 53 |
| RTU Open Troubleshooting | 54 |
| Outdoor Air Enthalpy Control | 55 |
| Differential Enthalpy Control | 55 |
| Return Air Enthalpy Sensor | 55 |
| Smoke Detector | 55 |
| Step 11 - Adjust Factory-Installed Options | 56 |
| Step 12 - Install Accessories | 56 |
| Step 13 - Check Belt Tension | 57 |
| Pre-Start and Start-Up | 58 |
| UNIT START-UP CHECKLIST | 59 |

SAFETY CONSIDERATIONS

Improper installation, adjustment, alteration, service, maintenance, or use can cause explosion, fire, electrical shock or other conditions which may cause personal injury or property damage. Consult a qualified installer, service agency, or your distributor or branch for information or assistance. The qualified installer or agency must use factory-authorized kits or accessories when modifying this

product. Refer to the individual instructions packaged with the kits or accessories when installing.

Follow all safety codes. Wear safety glasses and work gloves. Use quenching cloths for brazing operations and have a fire extinguisher available. Read these instructions thoroughly and follow all warnings or cautions attached to the unit. Consult local building codes and appropriate national electrical codes (in USA, ANSI/NFPA70, National Electrical Code (NEC); in Canada, CSA C22.1) for special requirements.

It is important to recognize safety information. This is the safety-alert symbol . When you see this symbol on the unit and in instructions or manuals, be alert to the potential for personal injury.

Understand the signal words DANGER, WARNING, CAUTION, and NOTE. These words are used with the safety-alert symbol. DANGER identifies the most serious hazards which **will** result in severe personal injury or death. WARNING signifies hazards which **could** result in personal injury or death. CAUTION is used to identify unsafe practices, which **may** result in minor personal injury or product and property damage. NOTE is used to highlight suggestions which **will** result in enhanced installation, reliability, or operation.

 **WARNING**

ELECTRICAL SHOCK HAZARD

Failure to follow this warning could cause personal injury or death.

Before performing service or maintenance operations on unit, always turn off main power switch to unit and install lockout tag. Unit may have more than one power switch.

 **WARNING**

UNIT OPERATION AND SAFETY HAZARD

Failure to follow this warning could cause personal injury, death and/or equipment damage.

Puron® (R-410A) refrigerant systems operate at higher pressures than standard R-22 systems. Do not use R-22 service equipment or components on Puron refrigerant equipment.

 **WARNING**

PERSONAL INJURY AND ENVIRONMENTAL HAZARD

Failure to follow this warning could cause personal injury or death.

Relieve pressure and recover all refrigerant before system repair or final unit disposal.

Wear safety glasses and gloves when handling refrigerants. Keep torches and other ignition sources away from refrigerants and oils.

⚠ CAUTION

CUT HAZARD

Failure to follow this caution may result in personal injury.
Sheet metal parts may have sharp edges or burrs. Use care and wear appropriate protective clothing, safety glasses and gloves when handling parts and servicing heat pump units.

Rated Indoor Airflow (cfm)

The table below lists the rated indoor airflow used for the AHRI efficiency rating for the units covered in this document.

| Model Number | Full Load Airflow (cfm) |
|--------------|-------------------------|
| 50HCQD12 | 4000 |

| | | | | | | | | | | | | | | | | | | |
|-----------|---|---|---|---|---|---|---|---|---|----|----|----|----|----|----|----|----|----|
| Position: | 1 | 2 | 3 | 4 | 5 | 6 | 7 | 8 | 9 | 10 | 11 | 12 | 13 | 14 | 15 | 16 | 17 | 18 |
| Example: | 5 | 0 | H | C | Q | D | 1 | 2 | A | 1 | A | 6 | - | 0 | B | 2 | A | 0 |

Unit/Series/Model

50HCQ - Packaged Rooftop Heat Pump

Refrig. Systems Options

D = Two Stage Cooling Models

Cooling Tons

12 - 10 ton

Sensor Options

- A = None
- B = RA Smoke Detector
- C = SA Smoke Detector
- D = RA + SA Smoke Detector
- E = CO₂
- F = RA Smoke Detector and CO₂
- G = SA Smoke Detector and CO₂
- H = RA + SA Smoke Detector and CO₂
- J = Condensate Overflow Switch
- K = Condensate Overflow Switch and RA Smoke Detectors
- L = Condensate Overflow Switch and RA and SA Smoke Detectors

Indoor Fan Options

- 1 = Standard Static Option – Belt Drive
- 2 = Medium Static Option – Belt Drive
- C = High Static Option with High Efficiency Motor – Belt Drive

Coil Options (Outdoor - Indoor - Hail Guard)

- A = Al/Cu - Al/Cu
- B = Precoat Al/Cu - Al/Cu
- C = E-coat Al/Cu - Al/Cu
- D = E-coat Al/Cu - E-coat Al/Cu
- E = Cu/Cu - Al/Cu
- F = Cu/Cu - Cu/Cu
- M = Al/Cu -Al/Cu — Louvered Hail Guard
- N = Precoat Al/Cu - Al/Cu — Louvered Hail Guard
- P = E-coat Al/Cu - Al/Cu — Louvered Hail Guard
- Q = E-coat Al/Cu - E-coat Al/Cu — Louvered Hail Guard
- R = Cu/Cu - Al/Cu — Louvered Hail Guard
- S = Cu/Cu - Cu/Cu — Louvered Hail Guard

Voltage

- 1 = 575/3/60
- 5 = 208-230/3/60
- 6 = 460/3/60

Packaging Options

- 0 = Standard
- 1 = LTL

Electrical Options

- A = None
- C = Non-Fused Disconnect
- D = Thru-The-Base Connections
- F = Non-Fused Disconnect and Thru-The-Base Connections
- G = 2-Speed Indoor Fan (VFD) Controller
- J = 2-Speed Indoor Fan (VFD) Controller and Non-Fused Disconnect
- K = 2-Speed Indoor Fan (VFD) Controller and Thru-The-Base Connections
- M = 2-Speed Indoor Fan (VFD) Controller with Non-Fused Disconnect and Thru-The-Base Connections

Service Options

- 0 = None
- 1 = Unpowered Convenience Outlet
- 2 = Powered Convenience Outlet
- 3 = Hinged Panels
- 4 = Hinged Panels and Unpowered Convenience Outlet
- 5 = Hinged Panels and Powered Convenience Outlet

Intake / Exhaust Options

- A = None
- B = Temperature Economizer w/ Barometric Relief
- F = Enthalpy Economizer w/ Barometric Relief
- K = 2-Position Damper
- U = Temperature Ultra Low Leak Economizer w/ Barometric Relief
- W = Enthalpy Ultra Low Leak Economizer w/ Barometric Relief

Base Unit Controls

- 0 = Electro-mechanical Controls can be used with W7212 EconoMiSer® IV (Non-Fault Detection and Diagnostic)
- 1 = PremierLink™ Controller
- 2 = RTU Open Multi-Protocol Controller
- 6 = Electro-mechanical with W7220 Economizer controller Controls. Can be used with W7220 EconoMiSer X (with Fault Detection and Diagnostic)

Design Revision

- = Factory Design Revision

a50-9989

Fig. 1 - 50HCQD12 Model Number Nomenclature (Example)

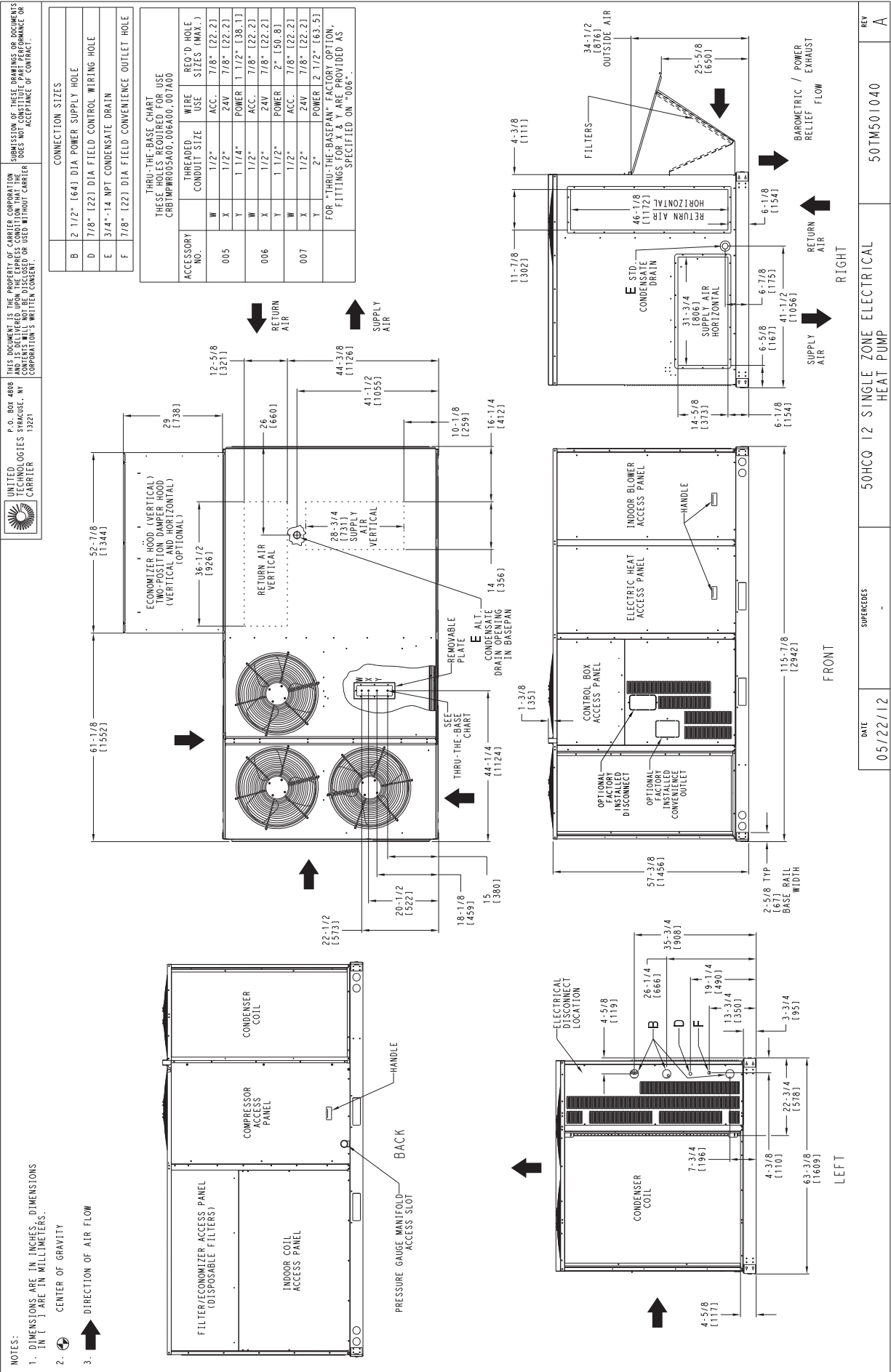

Fig. 2 - Unit Dimensional Drawing - 12 Size Unit

| UNIT | CORNER WEIGHT (A) | | CORNER WEIGHT (B) | | CORNER WEIGHT (C) | | CORNER WEIGHT (D) | | C.G. | | | | |
|----------|-------------------|-----|-------------------|-----|-------------------|-----|-------------------|-----|------|----|-------|--------------|--------------|
| | LBS. | KG. | LBS. | KG. | LBS. | KG. | LBS. | KG. | X | Y | Z | | |
| 50HC0012 | 1390 | 632 | 356 | 162 | 344 | 156 | 339 | 154 | 160 | 57 | 11448 | 31 1/2 (800) | 21 1/8 (537) |

STANDARD UNIT WEIGHT IS WITHOUT ELECTRIC HEAT & WITHOUT PACKAGING.
FOR OPTIONS & ACCESSORIES, REFER TO THE PRODUCT DATA CATALOG.



UNITED TECHNOLOGIES STRACON, NY 13221
CARRIER

THIS DOCUMENT IS THE PROPERTY OF CARRIER CORPORATION. SUBMISSION OF THESE DRAWINGS OR DOCUMENTS OF THIS TYPE SHALL BE CONSIDERED AS USED WITHOUT CARRIER CORPORATION'S WRITTEN CONSENT. DOES NOT CONSTITUTE PART PERFORMANCE OR ACCEPTANCE OF CONTRACT.

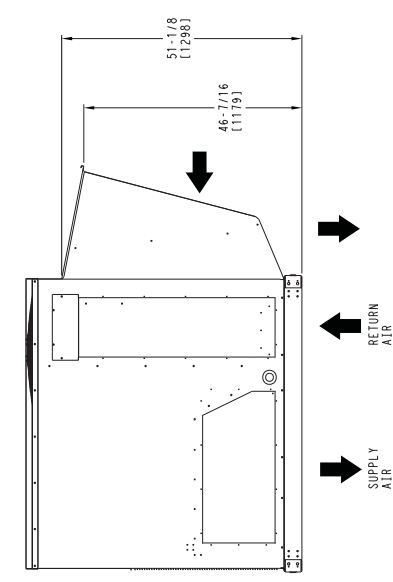
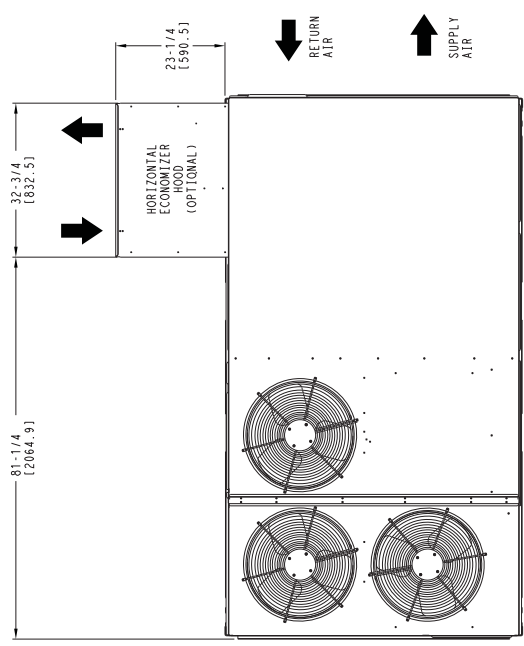
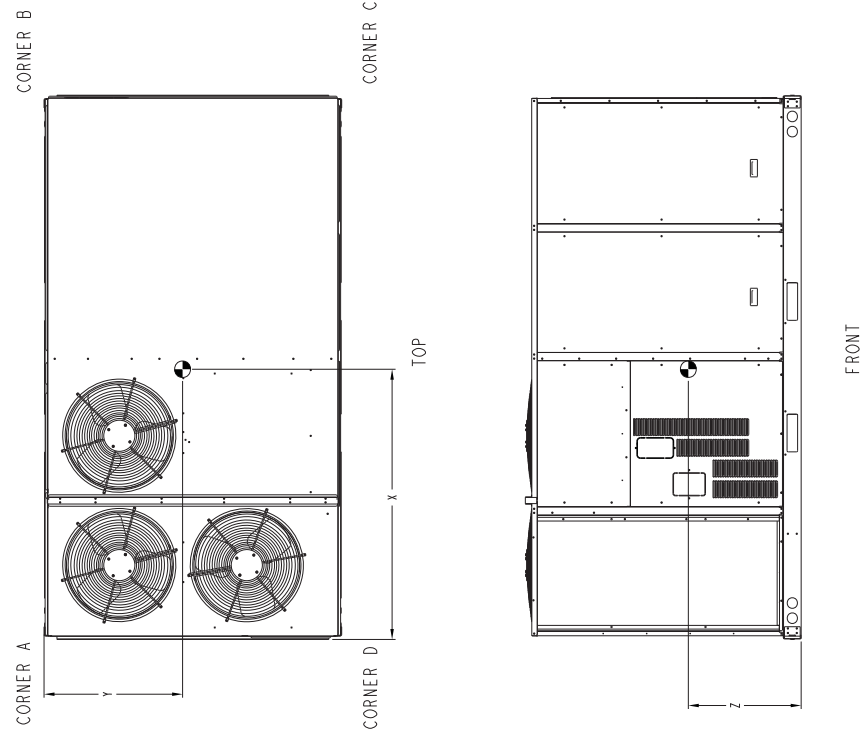

HORIZONTAL ECONOMIZER

| DATE | SUPERSEDES | 50HCO 12 SINGLE ZONE ELECTRICAL HEAT PUMP | 50TMS01040 | REV |
|----------|------------|---|------------|-----|
| 05/22/12 | - | | | A |

Fig. 2 - Unit Dimensional Drawing - 12 Size Unit (cont)

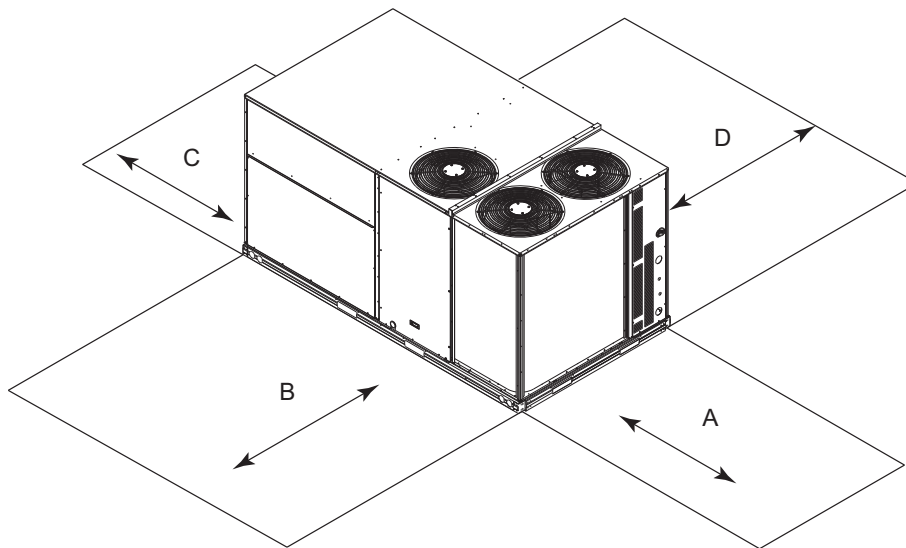

C09897B

| LOCATION | DIMENSION | CONDITION |
|----------|---|---|
| A | 48-in (1219 mm) 18-in (457 mm) 18-in (457 mm) 12-in (305 mm) | Unit disconnect is mounted on panel No disconnect, convenience outlet option Recommended service clearance Minimum clearance |
| B | 42-in (1067 mm) 36-in (914 mm) Special | Surface behind servicer is grounded (e.g., metal, masonry wall) Surface behind servicer is electrically non-conductive (e.g., wood, fiberglass) Check sources of flue products within 10-ft of unit fresh air intake hood |
| C | 36-in (914 mm) 18-in (457 mm) | Side condensate drain is used Minimum clearance |
| D | 42-in (1067 mm) 36-in (914 mm) | Surface behind servicer is grounded (e.g., metal, masonry wall, another unit) Surface behind servicer is electrically non-conductive (e.g., wood, fiberglass) |

NOTE: Unit not designed to have overhead obstruction. Contact Application Engineering for guidance on any application planning overhead obstruction or for vertical clearances.

Fig. 3 - Service Clearance Dimensional Drawing

REFRIGERATION SYSTEM COMPONENTS

Each heat pump refrigeration system includes a compressor, accumulator, reversing valve, dual-function outdoor coil with vapor header check valve, cooling liquid line with a filter drier and a check valve, dual-function indoor coil with a vapor header check valve, and heating liquid line with a check valve and a strainer. Size 14 units have two compressor-circuits. See Fig. 4 for typical unit piping schematic (4-row indoor coil with two compressor-circuits is shown).

Dual-function outdoor and indoor coils are designed to provide parallel coil circuits during evaporator-function operation and converging coil circuits during the condenser-function operation.

Reversing Valve and Check Valve Position

See Fig. 4 (on page 7) and Tables 1 - 3.

Troubleshooting Refrigerant Pressure Problems and Check Valves

Refer to Fig. 4 and the Cooling Mode and Heating Mode tables (Tables 1 and 2).

Refrigerant System Pressure Access Ports

There are two access ports in each circuit - on the suction tube and the discharge tube near the compressor. These are brass fittings with black plastic caps. The hose connection fittings are standard 1/4-inch SAE male flare couplings.

The brass fittings are two-piece High Flow valves, with a receptacle base brazed to the tubing and an integral spring-closed check valve core screwed into the base. See Fig. 5 on page 7. This check valve is permanently assembled into this core body and cannot be serviced separately. Replace the entire core body if necessary. Service tools are available from RCD that allow the replacement of the check valve core without having to recover the entire system refrigerant charge. Apply compressor refrigerant oil to the check valve core's bottom O-ring. Install the fitting body and torque to 96 ±10 in-lbs (10.9 ± 1 Nm). Do not exceed 106 in-lbs (11.9 Nm) when tightening.

Table 1 - Cooling Mode (each circuit)

| Component | Status/Position |
|-----------------|-----------------|
| Reversing Valve | Energized |
| Check Valve A | Closed |
| Check Valve B | Open |
| Check Valve C | Closed |
| Check Valve D | Open |

Table 2 – Heating Mode (each circuit)

| Component | Status/Position |
|-----------------|-----------------|
| Reversing Valve | De-energized |
| Check Valve A | Open |
| Check Valve B | Closed |
| Check Valve C | Open |
| Check Valve D | Closed |

Table 3 – Defrost Mode

| Component | Status/Position |
|--------------------|-----------------|
| Defrost Thermostat | Closed |
| Outdoor Fan(s) | Off |
| Reversing Valve | Energized |
| Check Valve A | Closed |
| Check Valve B | Open |
| Check Valve C | Closed |
| Check Valve D | Open |

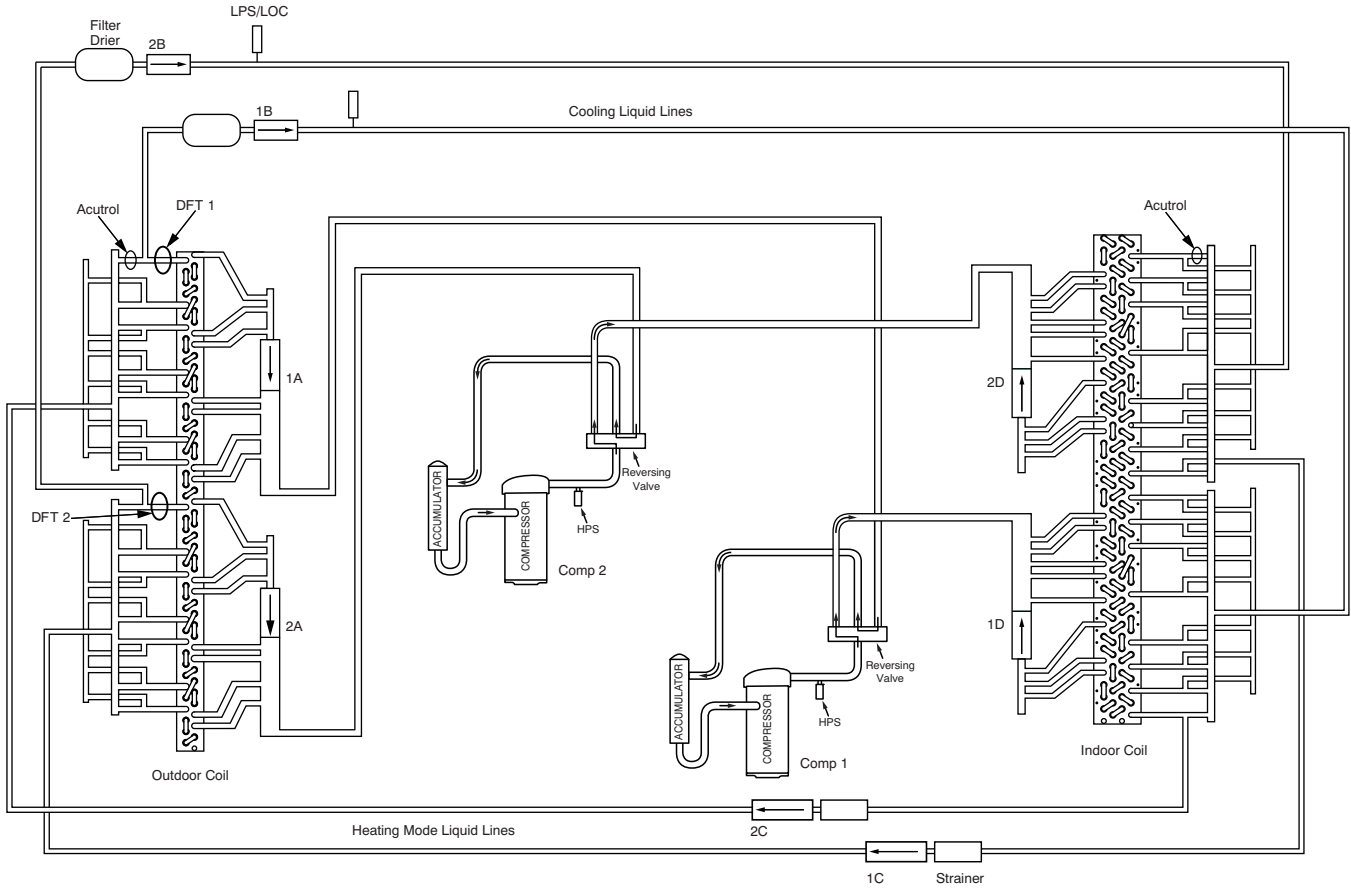

Fig. 4 - Typical Unit Piping Schematic

C160139

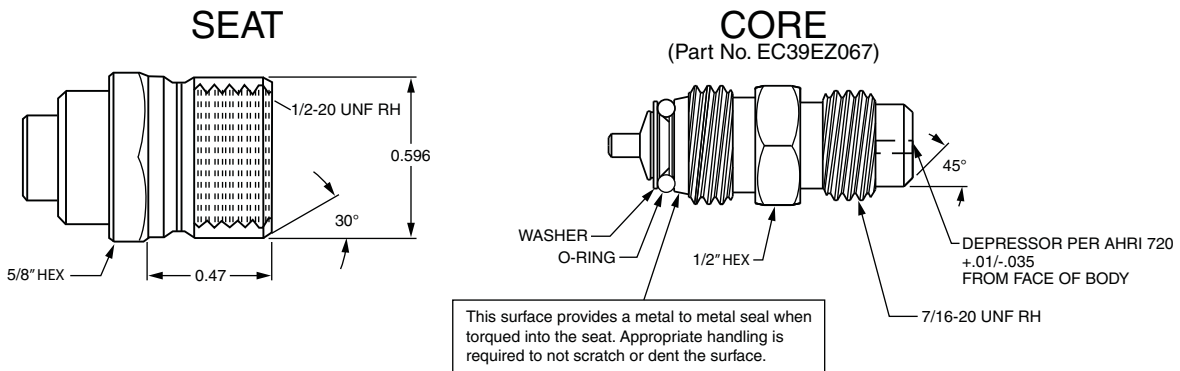

Fig. 5 - CoreMax* Access Port Assembly

a548J-009

* CoreMax is a registered trademark of Fastest, Inc.

INSTALLATION

Jobsite Survey

Complete the following checks before installation.

1. Consult local building codes and the NEC (National Electrical Code) ANSI/NFPA 70 for special installation requirements.
2. Determine unit location (from project plans) or select unit location.
3. Check for possible overhead obstructions which may interfere with unit lifting or rigging.

Step 1 — Plan for Unit Location

Select a location for the unit and its support system (curb or other) that provides for at least the minimum clearances required for safety. This includes the clearance to combustible surfaces, unit performance and service access below, around and above unit as specified in unit drawings. See Fig. 3.

NOTE: Consider also the effect of adjacent units.

Unit may be installed directly on wood flooring or on Class A, B, or C roof-covering material when roof curb is used.

Do not install unit in an indoor location. Do not locate air inlets near exhaust vents, relief valves, or other sources of contaminated air.

Although unit is weatherproof, avoid locations that permit water from higher level runoff and overhangs to fall onto the unit.

Select a unit mounting system that provides adequate height to allow for removal and disposal of frost and ice that will form during the heating-defrost mode as well as allow installation of condensate trap per requirements. Refer to Step 9 — Install External Condensate Trap and Line – for required trap dimensions.

Roof Mount —

Check building codes for weight distribution requirements. Unit operating weight is shown in Table 4.

Table 4 – Operating Weights

| 50HCQD12 | |
|----------------|---------------|
| COMPONENT | UNITS LB (KG) |
| Base Unit | 1390 (632) |
| Economizer | |
| Vertical | 100 (45) |
| Horizontal | 115 (52) |
| Powered Outlet | 32 (15) |
| Curb | |
| 14-in/356 mm | 180 (82) |
| 24-in/610 mm | 235 (107) |

Step 2 — Plan for Sequence of Unit Installation

The support method used for this unit will dictate different sequences for the steps of unit installation. For example, on curb-mounted units, some accessories must be

installed on the unit before the unit is placed on the curb. Review the following for recommended sequences for installation steps.

Curb-Mounted Installation —

- Install curb
- Install field-fabricated ductwork inside curb
- Install accessory thru-base service connection package (affects curb and unit) (refer to accessory installation instructions for details)
- Prepare bottom condensate drain connection to suit planned condensate line routing (refer to Step 9 on page 13 for details)
- Rig and place unit
- Install outdoor air hood
- Install condensate line trap and piping
- Make electrical connections
- Install other accessories

Pad-Mounted Installation —

- Prepare pad and unit supports
- Check and tighten the bottom condensate drain connection plug
- Rig and place unit
- Convert unit to side duct connection arrangement
- Install field-fabricated ductwork at unit duct openings
- Install outdoor air hood
- Install condensate line trap and piping
- Make electrical connections
- Install other accessories

Frame-Mounted Installation —

Frame-mounted applications generally follow the sequence for a curb installation. Adapt as required to suit specific installation plan.

Step 3 — Inspect Unit

Inspect unit for transportation damage. File any claim with transportation agency.

Confirm before installation of unit that voltage, amperage and circuit protection requirements listed on unit data plate agree with power supply provided.

Step 4 — Provide Unit Support

Roof Curb Mount —

Accessory roof curb details and dimensions are shown in Fig. 6. Assemble and install accessory roof curb in accordance with instructions shipped with the curb.

NOTE: The gasketing of the unit to the roof curb is critical for a watertight seal. Install gasket supplied with the roof curb as shown in Fig. 6. Improperly applied gasket can also result in air leaks and poor unit performance.

Curb should be level. This is necessary for unit drain to function properly. Unit leveling tolerances are shown in Fig. 7. Refer to Accessory Roof Curb Installation Instructions for additional information as required.

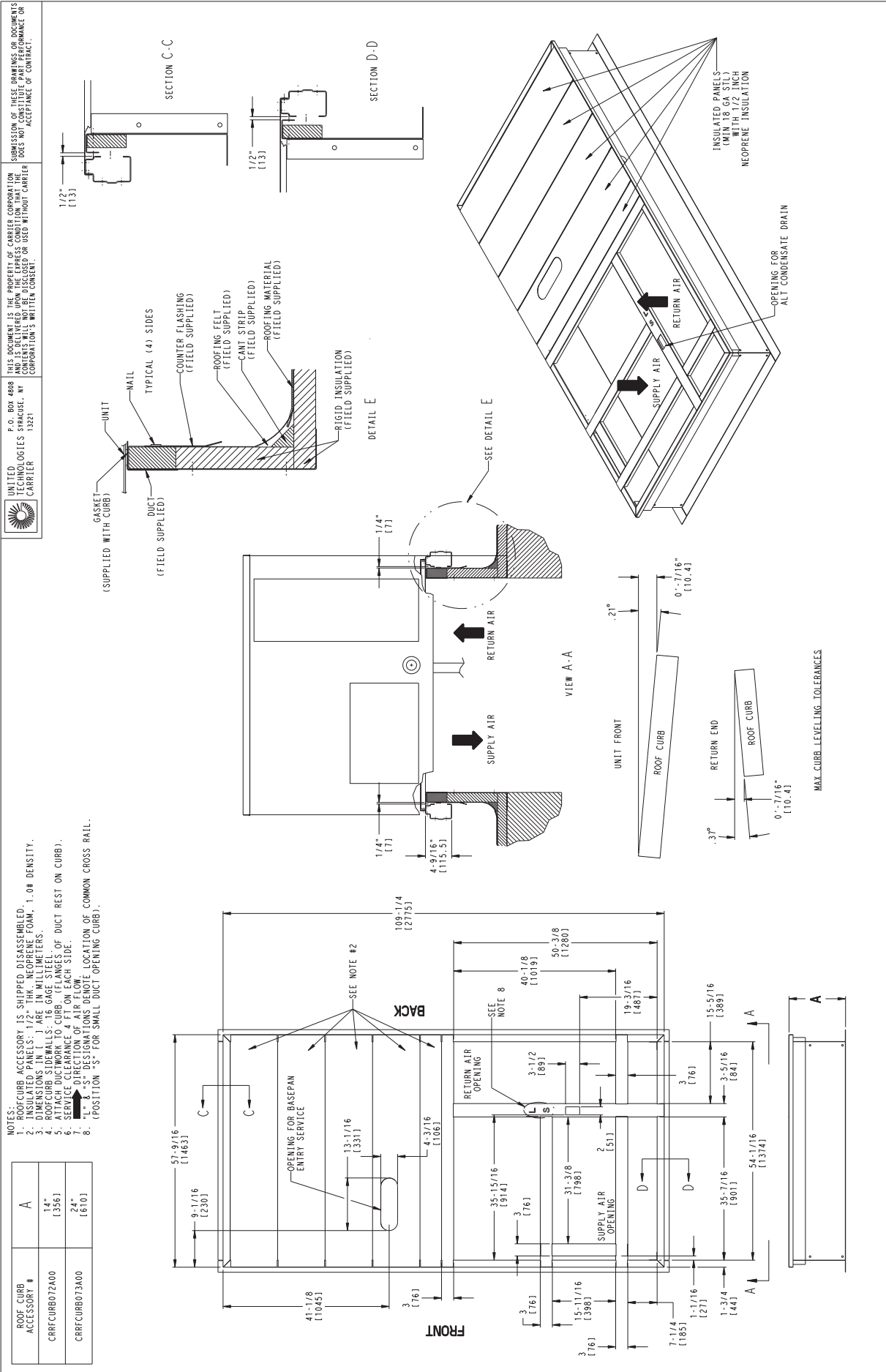

Fig. 6 - Roof Curb Details

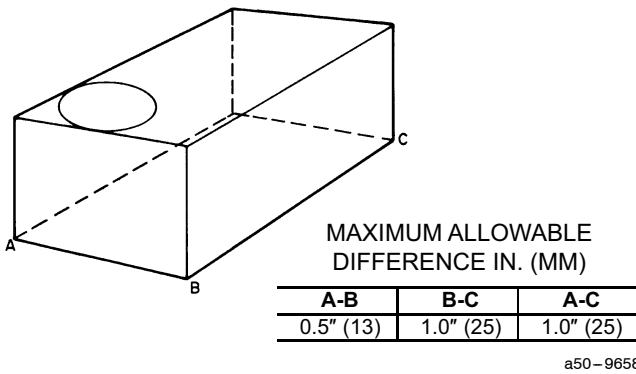

Fig. 7 - Unit Leveling Tolerances

Install insulation, cant strips, roofing felt, and counter flashing as shown. *Ductwork must be attached to curb and not to the unit.*

If electric and control wiring is to be routed through the basepan, attach the accessory thru-the-base service connections to the basepan in accordance with the accessory installation instructions.

Slab Mount (Horizontal Units Only) —

Provide a level concrete slab that extends a minimum of 6 in. (150 mm) beyond unit cabinet. Install a gravel apron in front of condenser coil air inlet to prevent grass and foliage from obstructing airflow.

NOTE: Horizontal units may be installed on a roof curb if required.

Alternate Unit Support (In Lieu of Curb or Slab Mount) —

A non-combustible sleeper rail can be used in the unit curb support area. If sleeper rails cannot be used, support the long sides of the unit with a minimum of 3 equally spaced 4-in. x 4-in. (102 mm x 102 mm) pads on each side.

Step 5 — Field Fabricate Ductwork

Cabinet return-air static pressure (a negative condition) shall not exceed 0.35 in. wg (87 Pa) with economizer or 0.45 in. wg (112 Pa) without economizer.

For vertical ducted applications, secure all ducts to roof curb and building structure. *Do not connect ductwork to unit.*

Insulate and weatherproof all external ductwork, joints, and roof openings with counter flashing and mastic in accordance with applicable codes.

Ducts passing through unconditioned spaces must be insulated and covered with a vapor barrier.

If a plenum return is used on a vertical unit, the return should be ducted through the roof deck to comply with applicable fire codes.

⚠ CAUTION

PROPERTY DAMAGE HAZARD

Failure to follow this caution may result in damage to roofing materials.

Membrane roofs can be cut by sharp sheet metal edges. Be careful when placing any sheet metal parts on such roof.

For Units with Accessory Electric Heaters —

All installations require a minimum clearance to combustible surfaces of 1-in. (25 mm) from duct for first 12-in. (305 mm) away from unit.

Step 6 — Rig and Place Unit

When the unit is ready to be rigged and no longer will be lifted by a fork truck, the wood protector under the basepan must be removed. Remove 4 screws from each base rail. Wood protector will drop to the ground. See instructions on the unit base rails.

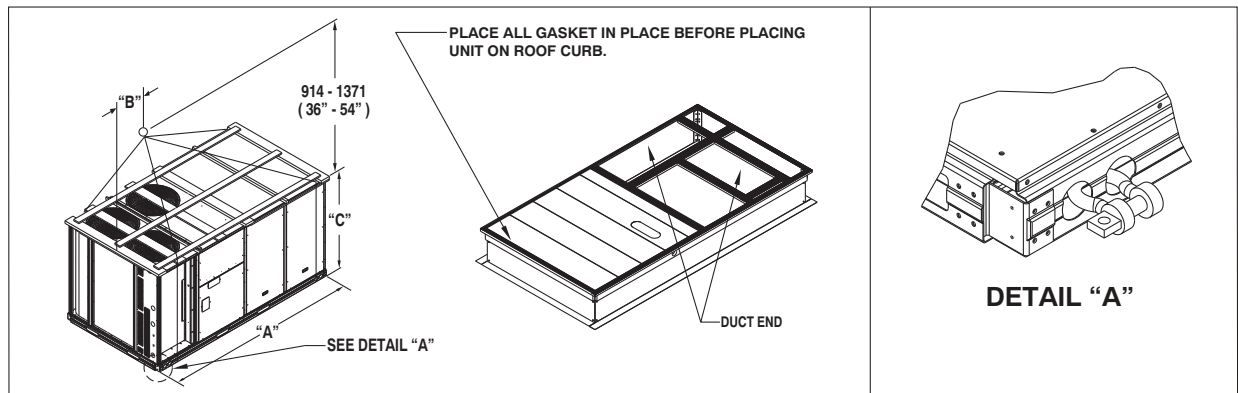

| UNIT | MAX WEIGHT | | DIMENSIONS | | | | | |
|----------|------------|-----|------------|------|------|------|------|------|
| | | | A | | B | | C | |
| | LB | KG | IN | MM | IN | MM | IN | MM |
| 50HCQD12 | 2075 | 943 | 116.0 | 2945 | 58.5 | 1485 | 59.5 | 1510 |

NOTES:

1. Dimensions in () are in millimeters.
2. Hook rigging shackles through holes in base rail, as shown in detail "A." Holes in base rails are centered around the unit center of gravity. Use wooden top to prevent rigging straps from damaging unit.

Fig. 8 - Rigging Details

Keep unit upright and do not drop. Spreader bars are required. Rollers may be used to move unit across a roof. Level by using unit frame as a reference. See Table 4 and Fig. 8 for additional information.

Lifting holes are provided in base rails as shown in Fig. 8. Refer to rigging instructions on unit.

Rigging materials under unit (cardboard or wood) must be removed PRIOR to placing the unit on the roof curb.

⚠ CAUTION

UNIT DAMAGE HAZARD

Failure to follow this caution may result in equipment damage.

All panels must be in place when rigging. Unit is not designed for handling by fork truck.

Before setting the unit onto the curb, recheck gasketing on curb.

Positioning on Curb —

For full perimeter curbs CRRFCURB072A00 and 073A00, the clearance between the roof curb and the front and rear base rails should be 1/4 in. (6.4 mm). The clearance between the curb and the end base rails should be 1/2 in. (13 mm). For retrofit applications with curbs CRRFCURB003A01 and 4A01, the unit should be position as shown in Fig. 9. Maintain the 15 1/2 in. (394 mm) and 8 5/8 in. (220 mm) clearances and allow the 22 5/16 in. (567 mm) dimension to float if necessary.

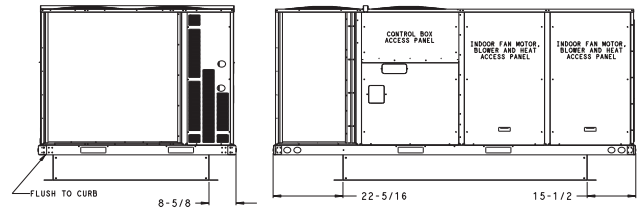

Fig. 9 - Retrofit Installation Dimensions

If the alternative condensate drain location through the bottom of the unit is used in conjunction with a retrofit curb, the hole in the curb must be moved 12 1/2 in. (320 mm) towards the end of the unit.

Although unit is weatherproof, guard against water from higher level runoff and overhangs.

Remove all shipping materials and top skid. Remove extra center post from the condenser end of the unit so that the condenser end of the unit matches Fig. 19 - 21. Recycle or dispose of all shipping materials.

Step 7 — Convert to Horizontal and Connect Ductwork (when required)

Unit is shipped in the vertical duct configuration. Unit *without* factory-installed economizer or return air smoke detector option may be field-converted to horizontal ducted configuration using accessory CRDUCTCV001A00. To convert to horizontal configuration, remove screws from side duct opening covers and remove covers.

Discard the supply duct cover. Install accessory CRDUCTCV001A00 to cover the vertical supply duct opening. Use the return duct cover removed from the end panel to cover the vertical return duct opening.

Field-supplied flanges should be attached to horizontal duct openings and all ductwork should be secured to the flanges. Insulate and weatherproof all external ductwork, joints, and roof or building openings with counter flashing and mastic in accordance with applicable codes.

Do not cover or obscure visibility to the unit's informative data plate when insulating horizontal ductwork.

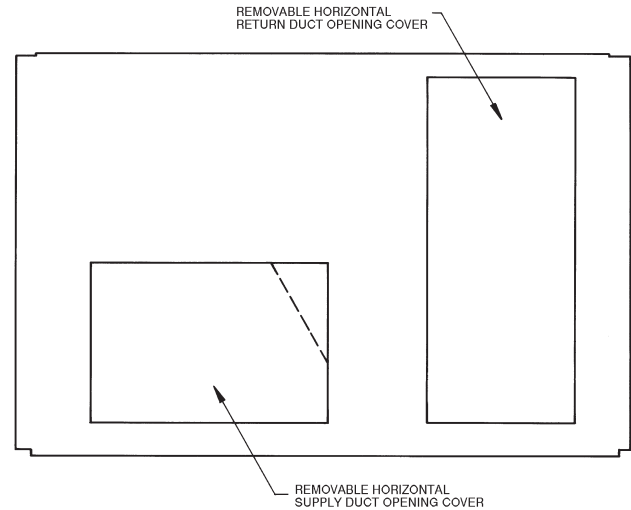

Fig. 10 - Horizontal Conversion Panels

Step 8 — Install Outside Air Hood

Economizer Hood Removal and Setup - Factory Option —

1. The hood is shipped in knock-down form and located in the return air compartment. It is attached to the economizer using two plastic tie-wraps.
2. To gain access to the hood, remove the filter access panel. (See Fig. 11.)

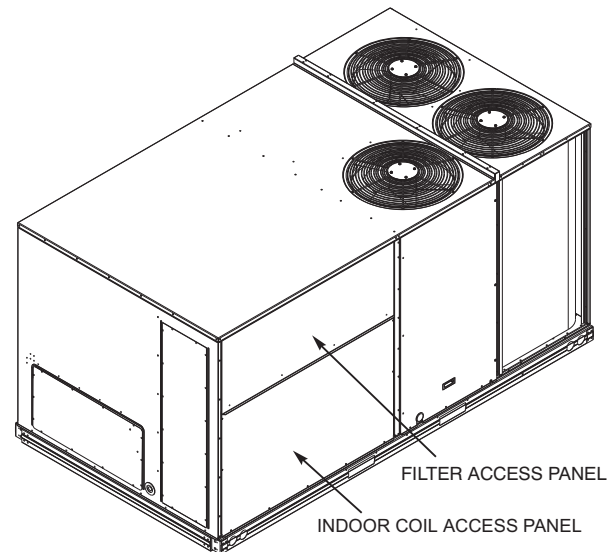

Fig. 11 - Typical Access Panel Locations

3. Locate and cut the (2) plastic tie-wraps, being careful to not damage any wiring. (See Fig. 12.)

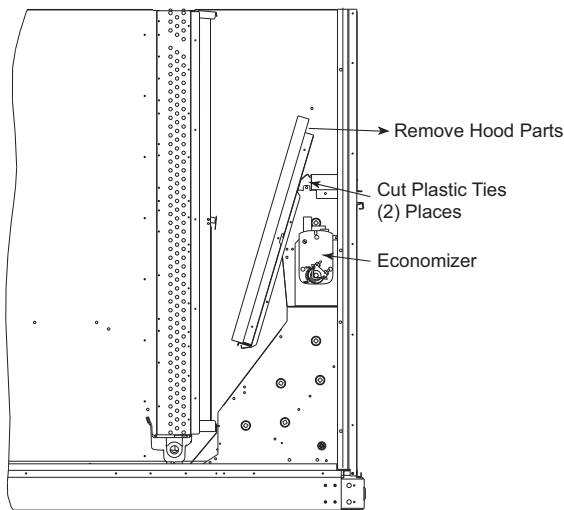

Fig. 12 - Economizer Wiring

C10005

4. Carefully lift the hood assembly through the filter access opening and assemble per the steps outlined in *Economizer Hood and Two-Position Hood*.

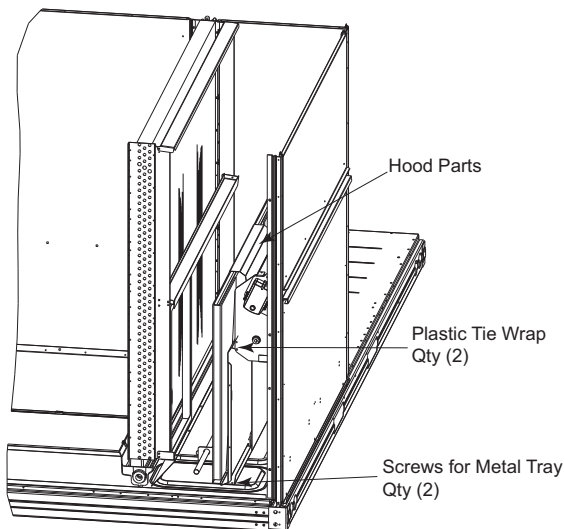

Fig. 13 - Damper Assembly

C10006

Two Position Damper Hood Removal and Setup - Factory Option —

1. The hood is shipped in knock-down form and assembled to a metal support tray using plastic stretch wrap. Located in the return air compartment, the assembly's metal tray is attached to the basepan and also attached to the damper using two plastic tie-wraps.
2. To gain access to the hood, remove the filter access panel. (See Fig. 11.)
3. Locate the (2) screws holding the metal tray to the basepan and remove. In order to remove the screws, it may be necessary to remove the panel underneath the two-position damper. Remove the two screws. Locate and cut the (2) plastic tie-wraps securing the assembly to the damper. (See Fig. 13.) Be careful to not damage any wiring or cut tie-wraps securing any wiring.

4. Carefully lift the hood assembly (with metal tray) through the filter access opening and assemble per the steps outlined in *Economizer Hood and Two-Position Hood*.

5. If removed, reattach the panel under the damper.

Economizer Hood and Two-Position Hood —

NOTE: If the power exhaust accessory is to be installed on the unit, the hood shipped with the unit will not be used and must be discarded. Save the aluminum filter for use in the power exhaust hood assembly.

1. The indoor coil access panel will be used as the top of the hood. If the panel is still attached to the unit, remove the screws along the sides and bottom of the panel. See Fig. 14.

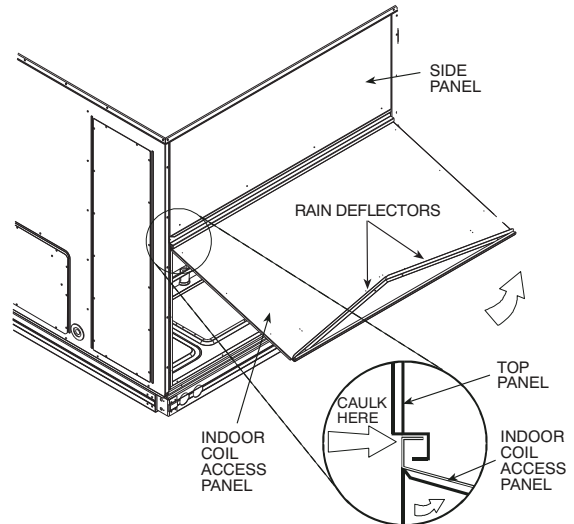

C10007

Fig. 14 - Indoor Coil Access Panel Relocation

2. Swing out indoor coil access panel and insert the hood sides under the panel (hood top). **Be careful not to lift the panel too far as it might fall out.** Use the screws provided to attach the hood sides to the hood top. Use screws provided to attach the hood sides to the unit. See Fig. 15.

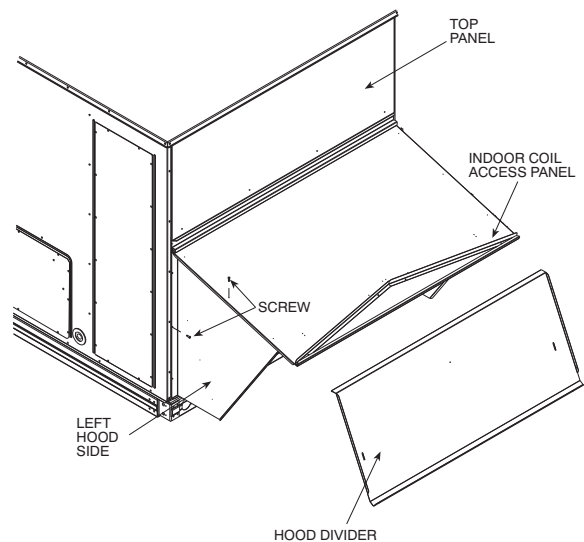

C10008

Fig. 15 - Economizer Hood Construction

- Remove the shipping tape holding the economizer barometric relief damper in place.
- Insert the hood divider between the hood sides. See Fig. 15 and 16. Secure hood divider with 3 screws on each hood side. The hood divider is also used as the bottom filter rack for the aluminum filter.
- Attach the post that separates the filters with the screws provided.
- Open the filter clips which are located underneath the hood top. Insert the aluminum filters into the bottom filter rack (hood divider). Push the filter into position past the open filter clips. Close the filter clips to lock the filters into place. See Fig. 16.

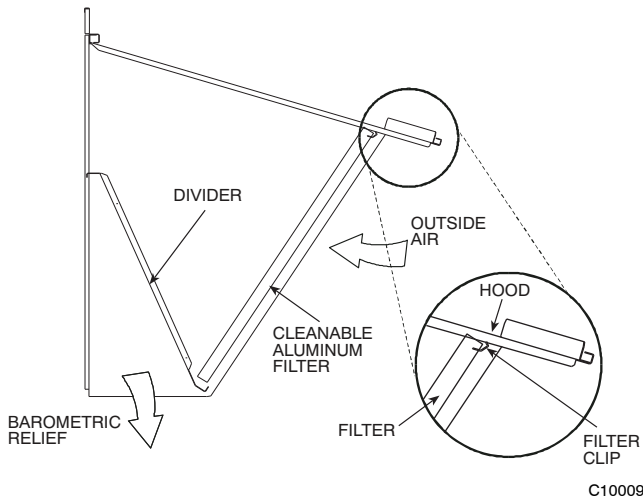

Fig. 16 - Economizer Filter Installation

- Install the two rain deflectors on the edge of the hood top as shown in Fig. 14.
- Caulk the ends of the joint between the unit top panel and the hood top as shown in Fig. 14.
- Replace the filter access panel.

Step 9 — Install External Condensate Trap and Line

The unit has one $\frac{3}{4}$ -in. condensate drain connection on the end of the condensate pan and an alternate connection on the bottom. See Fig. 17. Unit airflow configuration does not determine which drain connection to use. Either drain connection can be used with vertical or horizontal applications.

When using the standard side drain connection, ensure the red plug in the alternate bottom connection is tight. Do this before setting the unit in place. The red drain pan can be tightened with a $\frac{1}{2}$ -in. square socket drive extension.

To use the alternate bottom drain connection, remove the red drain plug from the bottom connection (use a $\frac{1}{2}$ -in. square socket drive extension) and install it in the side drain connection.

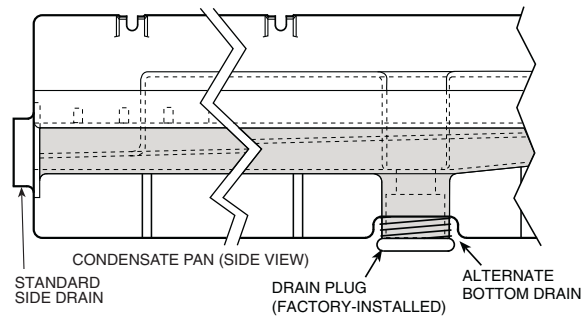
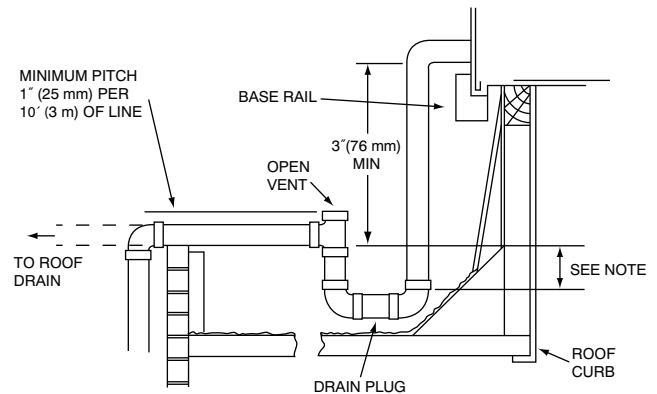

Fig. 17 - Condensate Drain Pan (Side View)

The piping for the condensate drain and external trap can be completed after the unit is in place. See Fig. 18.



NOTE: Trap should be deep enough to offset maximum unit static difference. A 4 in. (102 mm) trap is recommended.

Fig. 18 - Condensate Drain Piping Details

All units must have an external trap for condensate drainage. Install a trap at least 4-in. (102 mm) deep and protect against freeze-up. If drain line is installed downstream from the external trap, pitch the line away from the unit at 1-in. per 10 ft (25 mm in 3 m) of run. Do not use a pipe size smaller than the unit connection ($\frac{3}{4}$ -in.).

Step 10 — Make Electrical Connections

⚠ WARNING

ELECTRICAL SHOCK HAZARD

Failure to follow this warning could result in personal injury or death.

Do not use gas piping as an electrical ground. Unit cabinet must have an uninterrupted, unbroken electrical ground to minimize the possibility of personal injury if an electrical fault should occur. This ground may consist of electrical wire connected to unit ground lug in control compartment, or conduit approved for electrical ground when installed in accordance with NEC (National Electrical Code); ANSI/NFPA 70, latest edition (in Canada, Canadian Electrical Code CSA [Canadian Standards Association] C22.1), and local electrical codes.

NOTE: Check all factory and field electrical connections for tightness. Field-supplied wiring shall conform with the limitations of 63°F (33°C) rise.

Field Power Supply —

For those units without through-the-curb power, conduit must be used to route the main power from the condenser end of the unit to either the factory option disconnect, the bottom of the control box or the single point box accessory. 1 inch conduit is provided behind the access panel located under the control box. For those units that require conduit larger than 1 inch, it must be field supplied. Figures 19 - 21 show the various wire routings.

If the field disconnect is larger than 100A, it must be attached to the unit using accessory CRDISBKT001A00 (see Fig. 22). Follow the instructions provided with this accessory. For smaller field disconnects, be sure to use 1/2-in. screws to mount the disconnect directly to the end panel, following the instructions on the Field Disconnect Warning label (see Fig. 23). In either case, set the disconnect vertical location on the unit so that a 90 degree fitting can be used to connect the conduit to the disconnect.

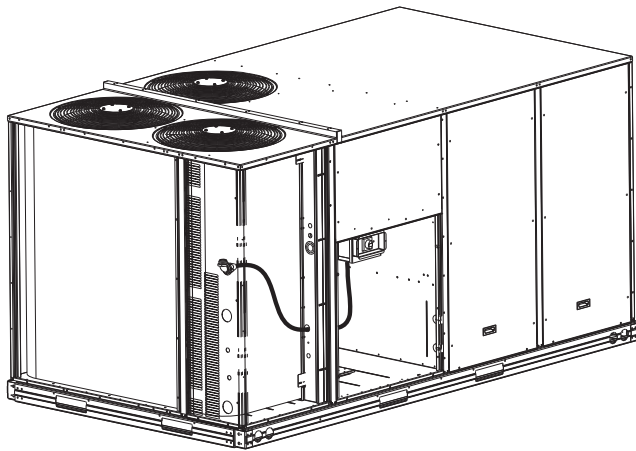

C10010

Fig. 19 - Conduit into Factory Option Disconnect

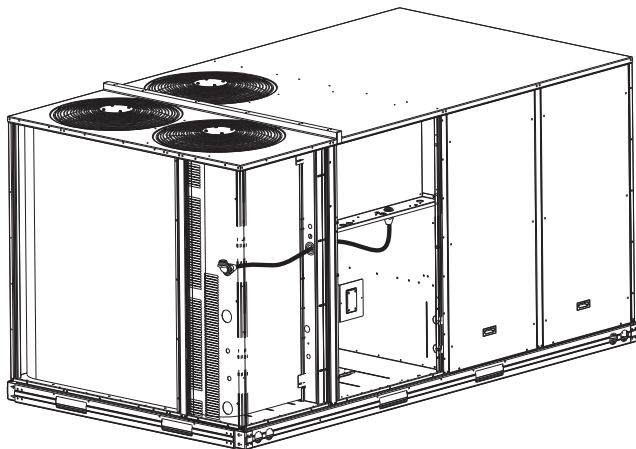

C10011

Fig. 20 - Conduit into Control Box

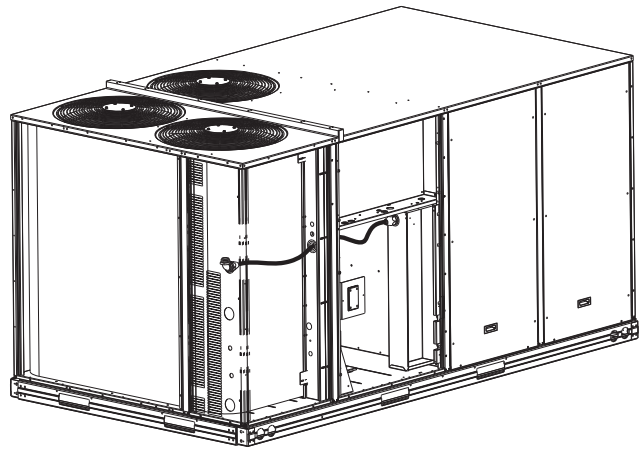

C10012

Fig. 21 - Conduit into Single Point Box

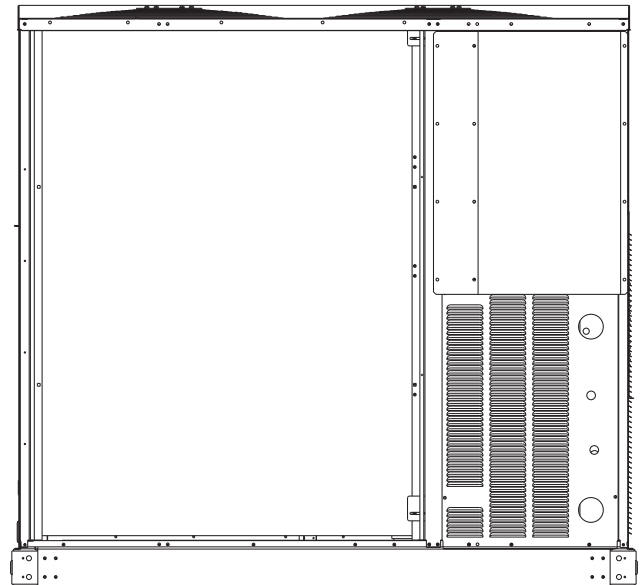

C10853

Fig. 22 - Mounting Position for Field Disconnects (over 100A)

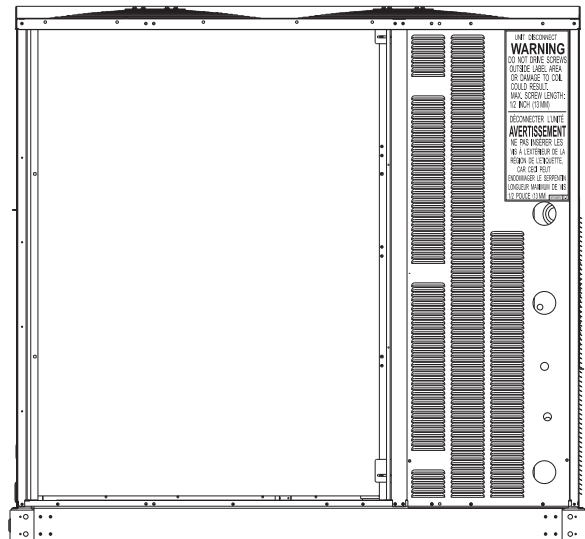

C10854

Fig. 23 - Mounting Position for Field Disconnects (up to 100A)

All units except 208/230-v units are factory wired for the voltage shown on the nameplate. *If the 208/230-v unit is to be connected to a 208-v power supply, the control transformer must be rewired by moving the black wire with the 1/4-in. female spade connector from the 230-v connection and moving it to the 200-v 1/4-in. male terminal on the primary side of the transformer.* Refer to unit label diagram for additional information.

Field power wires are connected to the unit at line-side pressure lugs at the main terminal block (TB1) or at factory-installed option non-fused disconnect switch. Max wire size is #2 AWG (copper only). (See Fig. 24.)

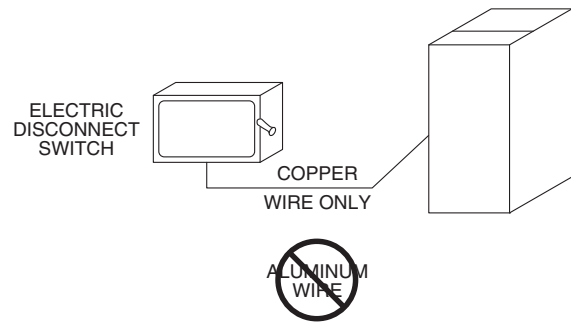
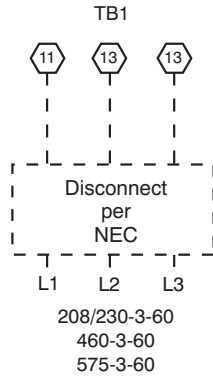

Fig. 25 - Disconnect Switch and Unit

A93033

Units Without Disconnect Option



Units With Disconnect Option

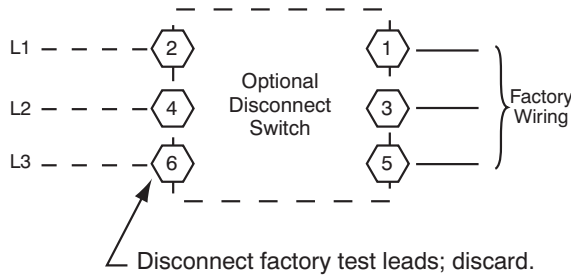

C10015

Fig. 24 - Power Wiring Connections

NOTE: TEST LEADS - Unit may be equipped with short leads (pigtailed) on the field line connection points off the optional disconnect switch. These leads are for factory run-test purposes only; remove and discard before connecting field power wires to unit connection points. Make field power connections directly to line connection pressure lugs only.

⚠ WARNING

FIRE HAZARD

Failure to follow this warning could result in intermittent operation or performance satisfaction. Do not connect aluminum wire between disconnect switch and furnace. Use only copper wire. (See Fig. 25.)

All Units —

All field wiring must comply with the NEC and local requirements.

Size wire based on MCA (Minimum Circuit Amps) on the unit informative plate. See Fig. 24 and the unit label diagram for power wiring connections to the unit power terminal blocks and equipment ground. Maximum wire size is #2/0 AWG per pole.

Provide a ground-fault and short-circuit over-current protection device (fuse or breaker) per NEC Article 440 (or local codes). Refer to unit informative data plate for MOCP (Maximum Over-current Protection) device size.

Voltage to compressor terminals during operation must be within voltage range indicated on unit nameplate. On 3-phase units, voltages between phases must be balanced within 2% and the current within 10%. Use the formula below to determine the percent of voltage imbalance.

$$\% \text{ Voltage Imbalance} = 100 \times \frac{\text{max voltage deviation from average voltage}}{\text{average voltage}}$$

Example: Supply voltage is 230-3-60



AB = 224 v
BC = 231 v
AC = 226 v

$$\text{Average Voltage} = \frac{(224 + 231 + 226)}{3} = \frac{681}{3} = 227$$

Determine maximum deviation from average voltage.

(AB) 227 - 224 = 3 v

(BC) 231 - 227 = 4 v

(AC) 227 - 226 = 1 v

Maximum deviation is 4 v.

Determine percent of voltage imbalance.

$$\% \text{ Voltage Imbalance} = 100 \times \frac{4}{227} = 1.76\%$$

This amount of phase imbalance is satisfactory as it is below the maximum allowable 2%.

IMPORTANT: If the supply voltage phase imbalance is more than 2%, contact your local electric utility company immediately.

Operation on improper line voltage or excessive phase imbalance constitutes abuse and may cause damage to electrical components. Such operation would invalidate any applicable Carrier warranty.

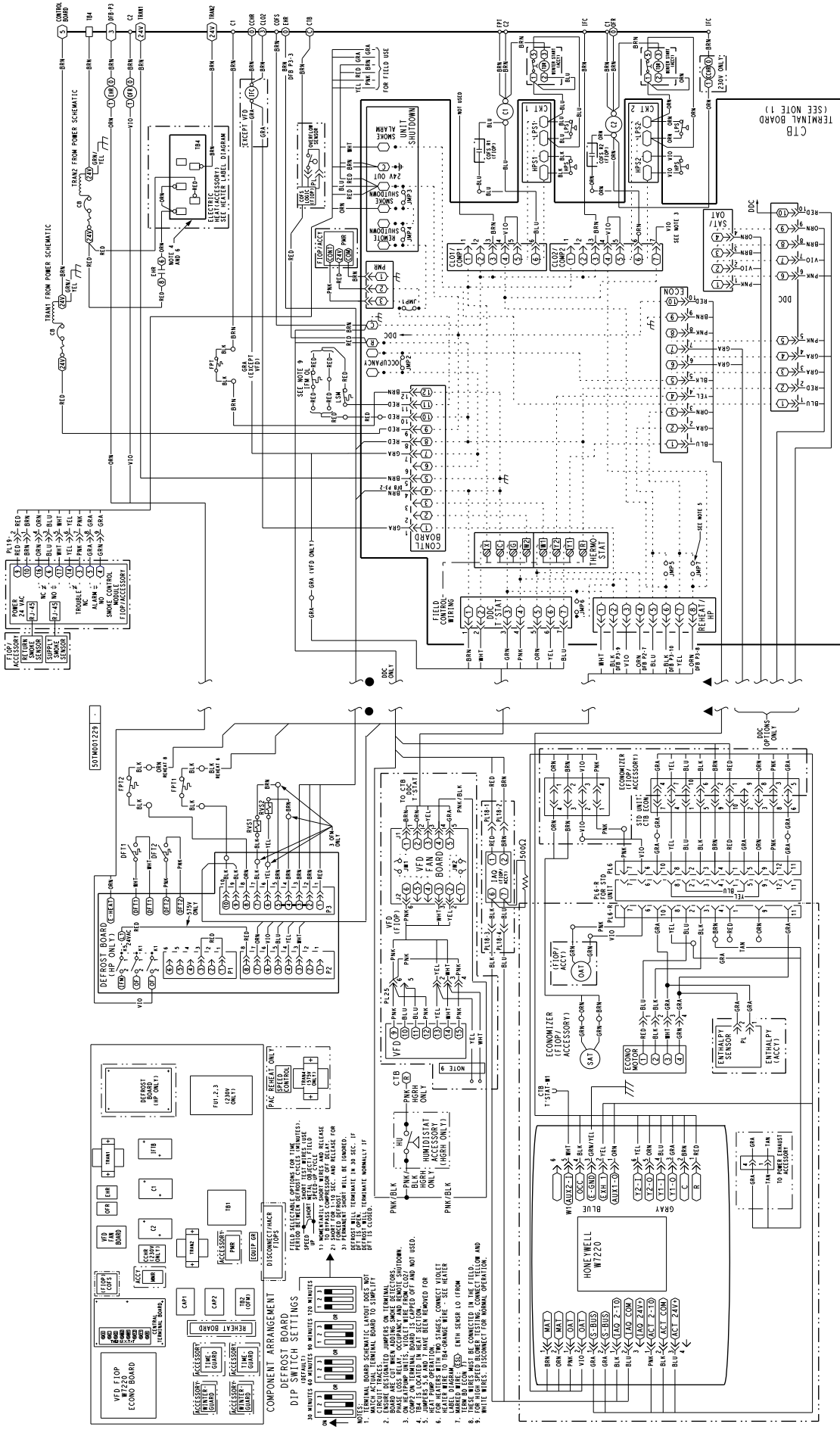

501M500814 1 P

Fig. 26 - Typical 50HCQ Control Wiring Diagram

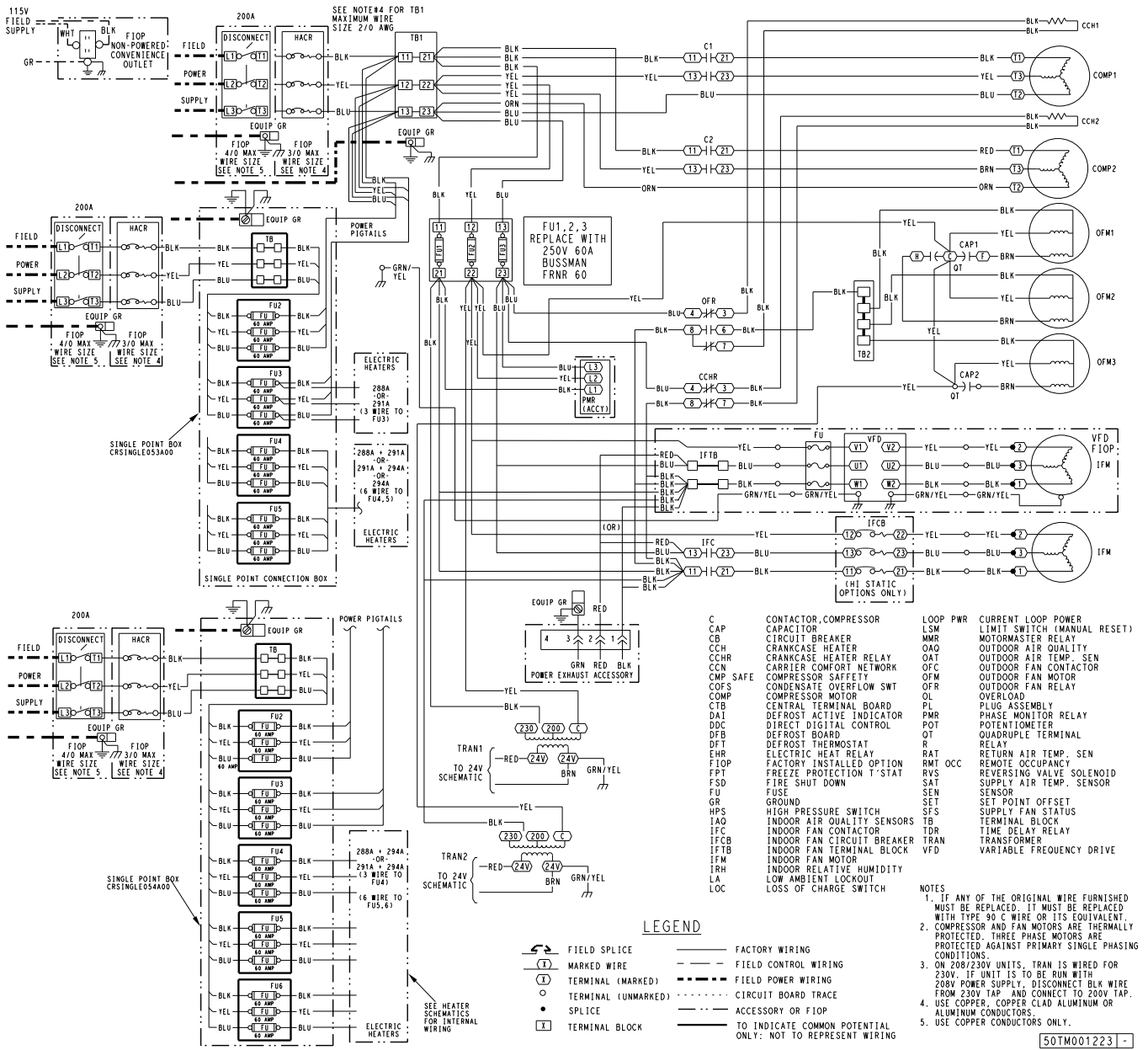

Fig. 27 - Typical 50HCQ Power Wiring Diagram (208/230V 3 Phase 60Hz unit shown)

a50-9708

Units Without Factory-Installed Non-Fused Disconnect —

When installing units, provide a disconnect switch of adequate size per NEC (National Electrical Code). Disconnect sizing data is provided on the unit informative plate. Locate on unit cabinet or within sight of the unit per national or local codes. Do not cover unit informative plate if mounting the disconnect on the unit cabinet.

Units with Factory-Installed Non-Fused Disconnect —

The factory-installed option disconnect switch is located in a weatherproof enclosure located under the main control box. The manual switch handle is accessible through an opening in the access panel. Discard the factory test leads (see Fig. 24). The factory disconnect is an 80A disconnect.

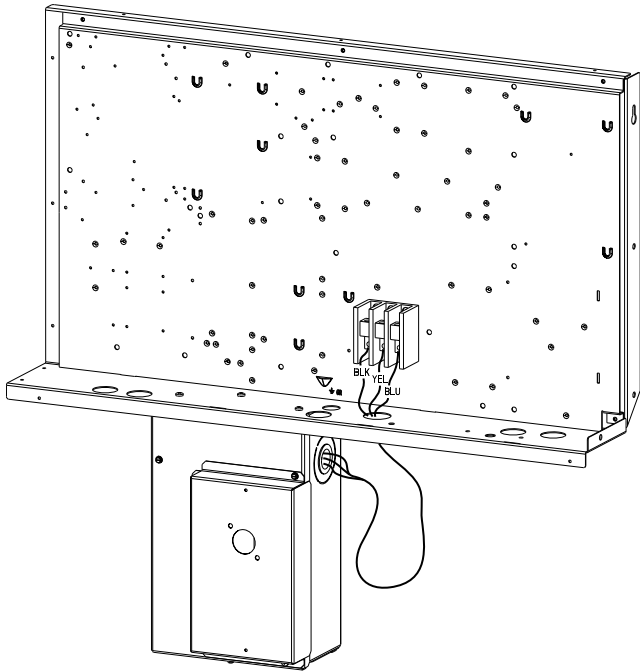

C12324

Fig. 28 - Location of Non-Fused Disconnect Enclosure

To field install the NFD shaft and handle:

1. Remove the unit front panel (see Fig. 2 on page 4).
2. Remove (3) hex screws on the NFD enclosure - (2) on the face of the cover and (1) on the bottom.
3. Remove the front cover of the NFD enclosure.
4. Make sure the NFD shipped from the factory is at OFF position (the arrow on the black handle knob is at OFF).
5. Insert the shaft with the cross pin on the top of the shaft in the horizontal position.
6. Measure the tip of the shaft to the top surface of the pointer to be 3.75 to 3.88 in. (95 to 99 mm) for 80A and 100A NFD and 3.43 to 3.56 in. (87 to 90 mm) for 200A NFD.
7. Tighten the locking screw to secure the shaft to the NFD.
8. Turn the handle to the OFF position with red arrow pointing at OFF.

9. Install the handle on to the painted cover horizontally with the red arrow pointing to the left.
10. Secure the handle to the painted cover with (2) screws and lock washers supplied.
11. Engaging the shaft into the handle socket, re-install (3) hex screws on the NFD enclosure.
12. Re-install the unit front panel.

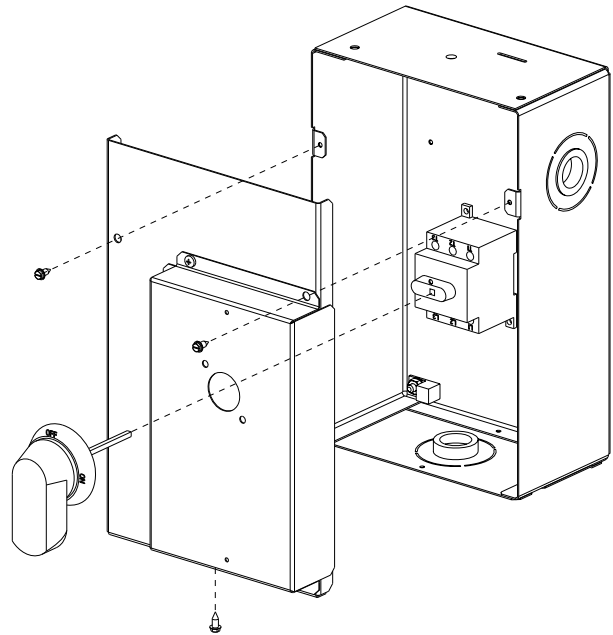

C12325

Fig. 29 - Handle and Shaft Assembly for NFD

Convenience Outlets —

⚠ WARNING

ELECTRICAL OPERATION HAZARD

Failure to follow this warning could result in personal injury or death.

Units with convenience outlet circuits may use multiple disconnects. Check convenience outlet for power status before opening unit for service. Locate its disconnect switch, if appropriate, and open it. Tag-out this switch, if necessary.

Two types of convenience outlets are offered as factory-installed options on 50HCQ units: Non-powered and unit-powered. Both types provide a 125-volt GFCI (ground-fault circuit-interrupter) duplex receptacle rated at 15-A behind a hinged waterproof access cover, located on the end panel of the unit. See Fig. 30.

A 20 amp non-powered convenience outlet is available as a field-installed accessory.

Non-powered type: This type requires the field installation of a general-purpose 125-volt 15-A circuit powered from a source elsewhere in the building. Observe national and local codes when selecting wire size and conduit requirements, fuse or breaker requirements and disconnect switch size and location. Route 125-v power supply conductors into the bottom of the utility box containing the duplex receptacle.

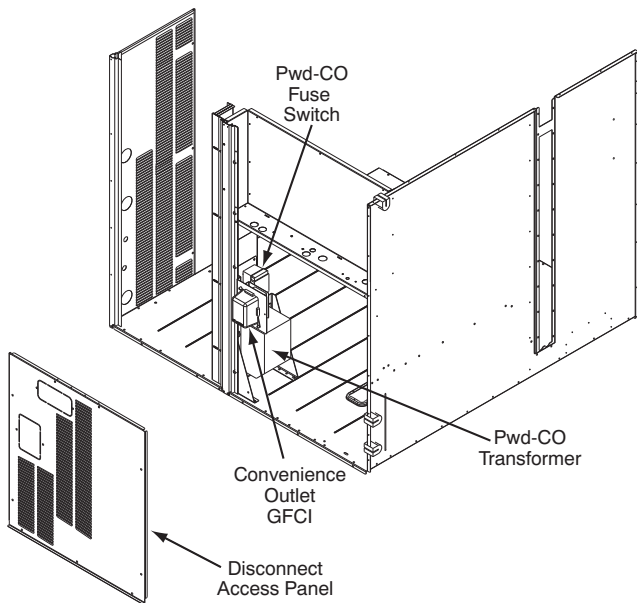

Fig. 30 - Convenience Outlet Location

C10857

Unit-powered type: A unit-mounted transformer is factory-installed to stepdown the main power supply voltage to the unit to 115-v at the duplex receptacle. This option also includes a manual switch with fuse, located in a utility box and mounted on a bracket behind the convenience outlet; access is through the panel beneath the control box. See Fig. 30.

The primary leads to the convenience outlet transformer are not factory-connected. Selection of primary power source is a customer-option. If local codes permit, the transformer primary leads can be connected at the line-side terminals on the unit-mounted non-fused disconnect switch; this will provide service power to the unit when the unit disconnect switch is open. Other connection methods will result in the convenience outlet circuit being de-energized when the unit disconnect switch is open. See Fig. 31. On a unit without a unit-mounted disconnect, connect the source leads to the main terminal block (TB1).

If the convenience outlet transformer is connected to the line side of a field disconnect, the conduit provided with the unit must be used to protect the wire as they are routed from the transformer to the field disconnect. The end of the conduit with the straight connector attaches to the field disconnect. The other end does not need to connect to the transformer; however, the conduit must be routed so that all wiring is either in the conduit or behind the access panel.

If the convenience outlet transformer is connected to the line side of the factory disconnect option, route the wires through the web bushing located on the bottom of the disconnect box. For the load side wiring to the factory option disconnect, route the wires through the hole on the right side of the disconnect. Be sure to create a drip loop at least 6 inches long.

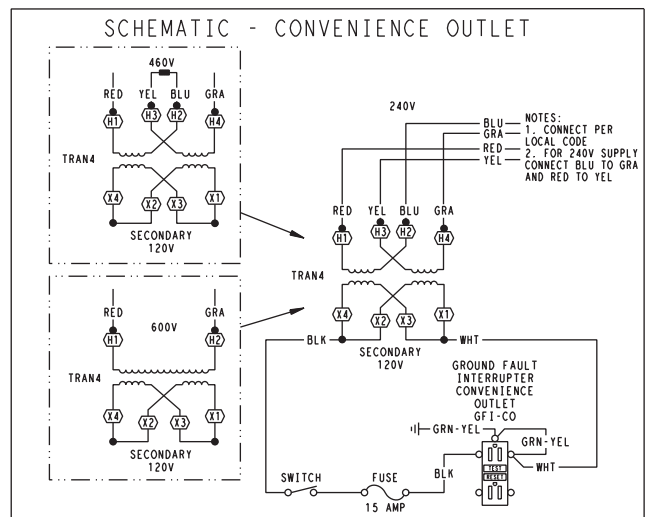

C08283

| UNIT VOLTAGE | CONNECT AS | PRIMARY CONNECTIONS | TRANSFORMER TERMINALS |
|--------------|------------|--|-----------------------|
| 208, 230 | 240 | L1: RED + YEL L2: BLU + GRA | H1 + H3 H2 + H4 |
| 460 | 480 | L1: RED L2: Splice BLU + YEL L2: GRA | H1 H2 + H3 H4 |
| 575 | 600 | L1: RED L2: GRA | H1 H2 |

Fig. 31 - Unit Powered Convenience Outlet Wiring

Duty Cycle: the unit-powered convenience outlet has a duty cycle limitation. The transformer is intended to provide power on an intermittent basis for service tools, lamps, etc; it is not intended to provide 15-amps loading for continuous duty loads (such as electric heaters for overnight use). Observe a 50% limit on circuit loading above 8-amps (i.e., limit loads exceeding 8-amps to 30 minutes of operation every hour).

Test the GFCI receptacle by pressing the TEST button on the face of the receptacle to trip and open the receptacle. Check for proper grounding wires and power line phasing if the GFCI receptacle does not trip as required. Press the RESET button to clear the tripped condition.

Fuse on power type: The factory fuse is a Bussman "Fusetron" T-15, non-renewable screw-in (Edison base) type plug fuse.

⚠ WARNING

ELECTRICAL OPERATION HAZARD

Failure to follow this warning could result in personal injury or death.

Using unit-mounted convenience outlets: Units with unit-mounted convenience outlet circuits will often require that two disconnects be opened to de-energize all power to the unit. Treat all units as electrically energized until the convenience outlet power is also checked and de-energization is confirmed. Observe National Electrical Code Article 210, Branch Circuits, for use of convenience outlets.

Installing Weatherproof Cover: A weatherproof while-in-use cover for the factory-installed convenience outlets is now required by UL standards. This cover cannot be factory-mounted due its depth; it must be installed at unit installation. For shipment, the convenience outlet is covered with a blank cover plate.

The weatherproof cover kit is shipped in the unit's control box. The kit includes the hinged cover, a backing plate and gasket.

DISCONNECT ALL POWER TO UNIT AND CONVENIENCE OUTLET.

Remove the blank cover plate at the convenience outlet; discard the blank cover.

Loosen the two screws at the GFCI duplex outlet, until approximately 1/2-in (13 mm) under screw heads are exposed. Press the gasket over the screw heads. Slip the backing plate over the screw heads at the keyhole slots and align with the gasket; tighten the two screws until snug (do not over-tighten).

Mount the weatherproof cover to the backing plate as shown in Fig. 32. Remove two slot fillers in the bottom of the cover to permit service tool cords to exit the cover. Check for full closing and latching.

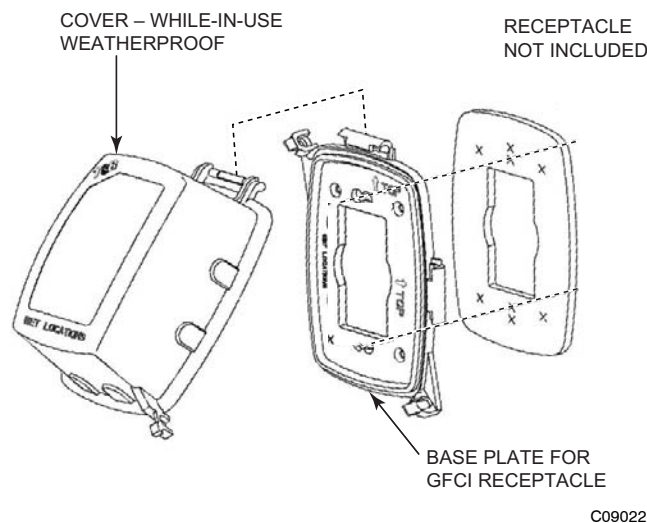

Fig. 32 - Weatherproof Cover Installation

Factory-Option Thru-Base Connections —

This service connection kit consists of a 1/2-in. electrical bulkhead connector and a 1 1/2-in. electrical bulkhead connector, all factory-installed to the basepan cover plate. Remove the cover plate from the shipping bracket and attach to basepan with 8 screws provided. The 1/2-in. bulkhead connector enables the low-voltage control wires to pass through the basepan. The 1 1/2-in. electrical bulkhead connector allows the high-voltage power wires to pass through the basepan. See Fig. 33.

Check tightness of connector lock nuts before connecting electrical conduits.

Field-supplied and field-installed liquidtight conduit connectors and conduit may be attached to the connectors on the basepan. Pull correctly rated high voltage and low

voltage wires through appropriate conduits. Connect the power conduit to the internal disconnect (if unit is so equipped) or to the external disconnect (through unit side panel). Remove one of the two knockouts located on the bottom left side of the unit control box. Use this hole for the control conduit.

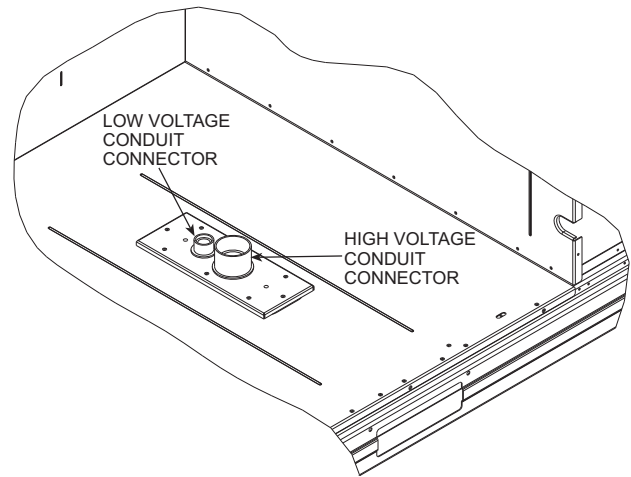

Fig. 33 - Thru-Base Connection Fittings

Units Without Thru-Base Connections —

1. Install power wiring conduit through side panel openings. Install conduit between disconnect and control box.
2. Install power lines to terminal connections as shown in Fig. 24.

Field Control Wiring —

The 50HCQD unit requires an external temperature control device. This device can be a thermostat (field-supplied) or a PremierLink™ controller (available as factory-installed option or as field-installed accessory, for use on a Carrier Comfort Network® (CCN) or as a stand alone control) or the RTU Open controller for Building Management Systems using non-CCN protocols (RTU Open controller is available as a factory-installed option only).

Thermostat —

Install a Carrier-approved accessory 2 stage Cooling/Heating thermostat according to installation instructions included with the accessory. The 50HCQ models do not require a thermostat with an O function to control the reversing valve operation. If using an electronic thermostat, configure it for “non-heat pump” operation. Locate the thermostat accessory on a solid wall in the conditioned space to sense average temperature in accordance with the thermostat installation instructions.

If the thermostat contains a logic circuit requiring 24-v power, use a thermostat cable or equivalent single leads of different colors with minimum of seven leads. If the thermostat does not require a 24-v source (no “C” connection required), use a thermostat cable or equivalent with minimum of six leads. Check the thermostat installation instructions for additional features which might require additional conductors in the cable.

For wire runs up to 50 ft. (15 m), use no. 18 AWG (American Wire Gage) insulated wire (35°C minimum). For 50 to 75 ft. (15 to 23 m), use no. 16 AWG insulated wire (35°C minimum). For over 75 ft. (23 m), use no. 14 AWG insulated wire (35°C minimum). All wire sizes larger than no. 18 AWG cannot be directly connected to the thermostat and will require a junction box and splice at the thermostat.

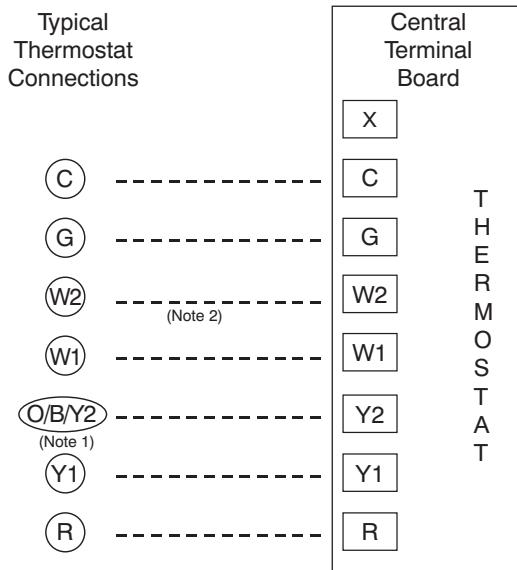

Note 1: Typical multi-function marking. Follow manufacturer's configuration instructions to select Y2. Do not configure for O output.

Note 2: W2 connection not required on units without electric heating.

--- Field Wiring

C09012

Fig. 34 - Typical Low-Voltage Control Connections

Central Terminal Board

The Central Terminal Board (CTB) is a pass through connection point. The CTB provides the capability to add factory-installed options and field-installed accessories to the units by cutting jumper wires without having to change or reroute wires through the structure of the unit. The CTB does not provide any microprocessor control; it is simply a basic multifunction wiring terminal configuration.

Commercial Defrost Control

The Commercial Defrost Control Board (DFB) coordinates thermostat demands for supply fan control, 1 or 2 stage cooling, 2 stage heating, emergency heating and defrost control with unit operating sequences. The DFB also provides an indoor fan off delay feature (user selectable). See Fig. 35 for board arrangement.

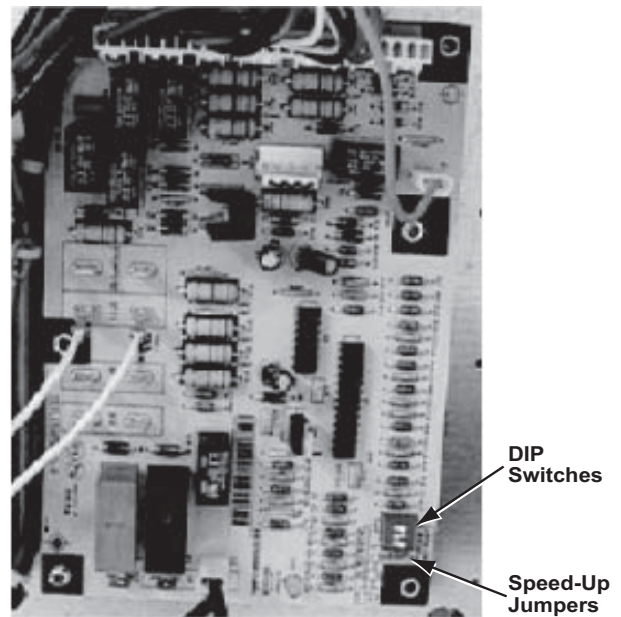

C09275

Fig. 35 - Defrost Control Board Arrangement

The DFB is located in the 50HCQ unit's main control box (see Fig. 2 on page 4). All connections are factory-made through harnesses to the unit's CTB, to IFC (belt-drive motor) or to ECM (direct-drive motor), reversing valve solenoids and to defrost thermostats. Refer to Table 5 for details of DFB Inputs and Outputs.

Reversing valve control — The DFB has two outputs for unit reversing valve control. Operation of the reversing valves is based on internal logic; this application does not use an "O" or "B" signal to determine reversing valve position. Reversing valves are energized during the cooling stages and the defrost cycle and de-energized during heating cycles. Once energized at the start of a cooling stage, the reversing valve will remain energized until the next heating cycle demand is received. Once de-energized at the start of a Heating cycle, the reversing valves will remain de-energized until the next cooling stage is initiated.

Compressor control — The DFB receives inputs indicating Stage 1 Cooling, Stage 2 Cooling and Stage 1 Heating from the space thermostat or unit control system (PremierLink™ controller or RTU Open controller); it generates commands to start compressors with or without reversing valve operation to produce Stage 1 Cooling (one compressor runs), Stage 2 Cooling (both compressors run) or Stage 1 Heating (both compressors run).

Auxiliary (Electric) Heat control — The 50HCQ unit can be equipped with one or two auxiliary electric heaters, to provide a second stage of heating. The DFB will energize this Heating System for a Stage 2 Heating Command (heaters operate concurrently with compressor(s) in the Stage 1 Heating cycle), for an Emergency Heating sequence (compressors are off and only the electric heaters are energized) and also during the Defrost cycle (to eliminate a "cold blow" condition in the space).

Table 5 – 50HCQ Defrost Board I/O and Jumper Configurations

Inputs

| Point Name | Type of I/O | Connection Pin Number | Unit Connection | Note |
|------------|-------------|-----------------------|-----------------|------|
| G Fan | DI, 24Vac | P2-3 | CTB-G | |
| Y1 Cool 1 | DI, 24Vac | P2-5 | CTB-Y1 | |
| Y2 Cool 2 | DI, 24Vac | P2-4 | CTB-Y2 | |
| W1 Heat 1 | DI, 24Vac | P2-7 | CTB-W1 | |
| W2 Heat 2 | DI, 24Vac | P2-6 | CTB-W2 | |
| R Power | 24Vac | P3-1 | CONTL BRD-8 | |
| C Common | 24Vac | P3-2 | CONTL BRD-4 | |
| DFT1 | DI, 24Vac | DFT-1 to DFT-1 | — | |
| DFT 2 | DI, 24Vac | DFT-2 to DFT-2 | — | |

Outputs

| Point Name | Type of I/O | Connection Pin Number | Unit Connection | Note |
|--------------|-------------|-----------------------|--------------------|------------------|
| IFO Fan On | DO, 24Vac | P3-9 | REHEAT/HP-2 | |
| OF OD Fan On | DO, 24Vac | OF | OFR | |
| RVS1 | DO, 24Vac | P3-7 to P3-5 | — | Energize in COOL |
| RVS2 | DO, 24Vac | P3-6 to P3-4 | — | Energize in COOL |
| COMP 1 | DO, 24Vac | P3-10 | FPT1 – REHEAT/HP-6 | |
| COMP 2 | DO, 24Vac | P3-8 | FPT2 – REHEAT/HP-8 | |
| HEAT 2 | DO, 24Vac | E-HEAT | TB4-1 | |
| COM | 24Vac | P3-3 | TB4-3 | |

Configuration

| Point Name | Type of I/O | Connection Pin Number | Unit Connection | Note |
|---------------|-------------|-----------------------|-----------------|----------------|
| Select Jumper | 24Vac | P1-1 | — | |
| 2 Compressor | 24Vac | P1-3 | — | Use for 50HCQD |

Speed-Up Configuration

| Point Name | Type of I/O | Connection Pin Number | Unit Connection | Note |
|-----------------|-------------|-----------------------|-----------------|------|
| Speed-Up Jumper | — | JMP17 | — | |
| Speed-Up Jumper | — | JMP18 | — | |

Jumper for 1–3 seconds: Factory Test — The defrost interval timing is reduced by a factor of 0.1 seconds/minute based on the positions of DIP switches SW1 and SW2 (i.e. 90 minutes will be reduced to 9 seconds).

Jumper for 5–20 seconds: Forced Defrost — Defrost runs for 30 seconds if DFT2 is open.

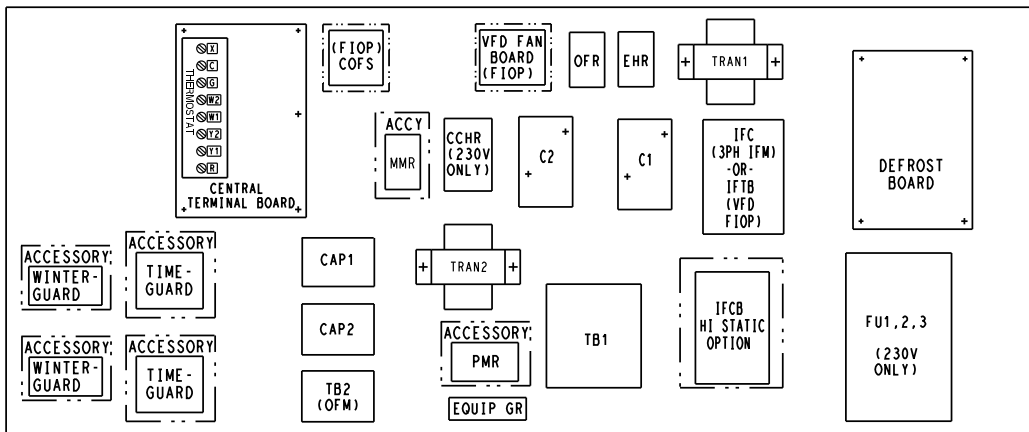

Fig. 36 - Defrost Control Board Location

a5-9709

Table 6 – DIP Switch Position

| Switch No. | 1 | 2 | 1 | 2 | 1 | 2 | 1 | 2 | 1 | 2 | 3 | |
|------------|------------|---|------------------------------|---|------------|---|-------------|---|-----------|---|---|-----|
| 1 | ■ | | 1 | ■ | 1 | | 1 | ■ | ■ | 1 | ■ | On |
| 0 | | ■ | 0 | ■ | 0 | ■ | ■ | 0 | | 0 | | Off |
| | 30 minutes | | 60 minutes (Factory default) | | 90 minutes | | 120 minutes | | Fan Delay | | | |

Defrost — The defrost control mode is a time/temperature sequence. There are two time components: The continuous run period and the test/defrost cycle period. The temperature component is provided by Defrost Thermostat 1 and 2 (DFT1 and DFT2) mounted on the outdoor coil.

The continuous run period is a fixed time period between the end of the last defrost cycle (or start of the current Heating cycle) during which no defrost will be permitted. This period can be set at 30, 60, 90 or 120 minutes by changing the positions of DIP switches SW1 and SW2 (see Fig. 37 and Table 6). The default run period is 60 minutes for size 14 units.

DIP SWITCH SETTINGS - DEFROST BD

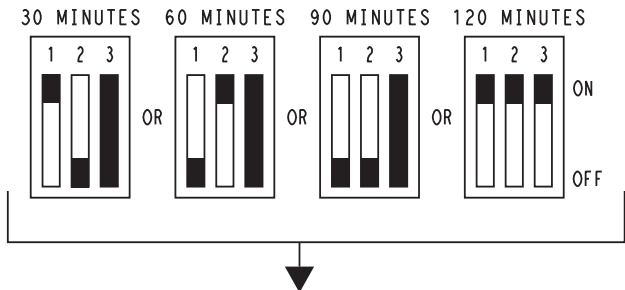

FIELD SELECTABLE OPTIONS FOR TIME PERIOD BETWEEN DEFROST CYCLES (MINUTES).

a50-9688

Fig. 37 - DIP Switch Settings — Defrost Board

Shorting the jumpers for a period of 5 to 20 seconds bypasses the remaining continuous run period and places the unit in a Forced Defrost mode. If the controlling DFT is closed when this mode is initiated, the unit will complete a normal defrost period that will terminate when the controlling DFT opens or the 10 minute defrost cycle limit is reached. If the controlling DFT is open when this mode is initiated, the Defrost cycle will run for 30 seconds. Both modes end at the end of the Defrost cycle.

Unit Without Thru-Base Connection Kit —

Pass the thermostat control wires through the bushing on the unit end panel. Route the wire through the snap-in wire tie and up to the web bushing near the control box. Route the wire through the bushing and into the bottom left side of the control box after removing one of the two knockouts in the corner of the box. Using a connector at the control box to protect the wire as it passes into the control box. Pull the wires over to the terminal strip at the upper left corner of the Central Terminal Board (CTB). Use the connector at the control box and the wire tie to ensure that the thermostat wire is tight and will not be damaged by contact with the condenser coil. See Fig. 38.

NOTE: If thru-the-bottom connections accessory is used, refer to the accessory installation instructions for information on routing power and control wiring.

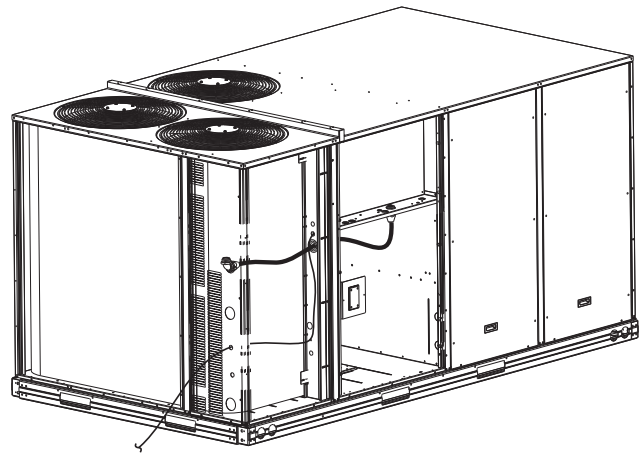

C10018

Fig. 38 - Thermostat Wire Routing

Heat Anticipator Settings —

Set heat anticipator settings at 0.14 amp for the first stage and 0.14 amp for second-stage heating, when available.

Electric Heaters

50HCQ units may be equipped with field-installed accessory electric heaters. The heaters are modular in design, with heater frames holding open coil resistance wires strung through ceramic insulators, line-break limit switches and a control contactor. One or two heater modules may be used in a unit.

Heater modules are installed in the compartment below the indoor (supply) fan outlet. Access is through the indoor access panel. Heater modules slide into the compartment on tracks along the bottom of the heater opening. See Fig. 39.

⚠ CAUTION

UNIT DAMAGE HAZARD
 Failure to follow this caution may result in equipment damage.

Not all available heater modules and single point boxes may be used in every unit. Use only those heater modules that are UL listed for use in a specific size unit. Refer to the label on the unit cabinet for the list of approved heaters and single point boxes.

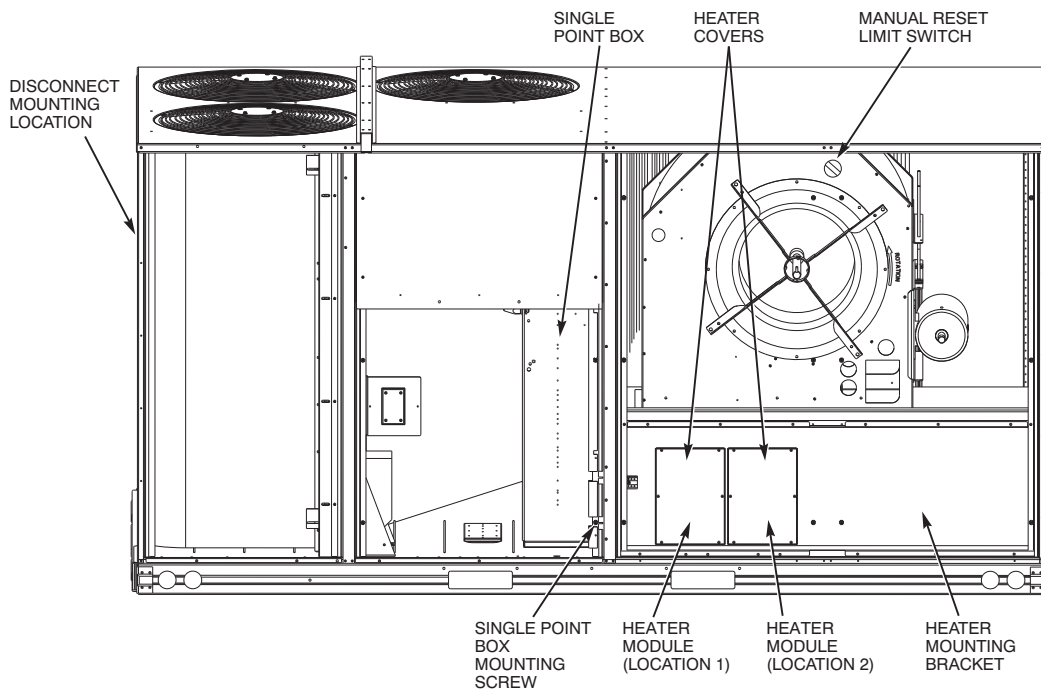

C10829

Fig. 39 - Typical Component Location

Single Point Boxes

When heaters are installed, power wiring to both heaters and the rest of the unit is connected via the single point box accessory, which will be installed directly under the unit control box, just to the left of the partition separating the indoor section (with electric heaters) from the outdoor section. The single point box has a hinged access cover. See Fig. 40. The single point box also includes pigtailed connections to complete the wiring between the single point box and the unit's main control box terminals. Refer to the accessory heater and Single Point Box installation instructions for details on tap connections.

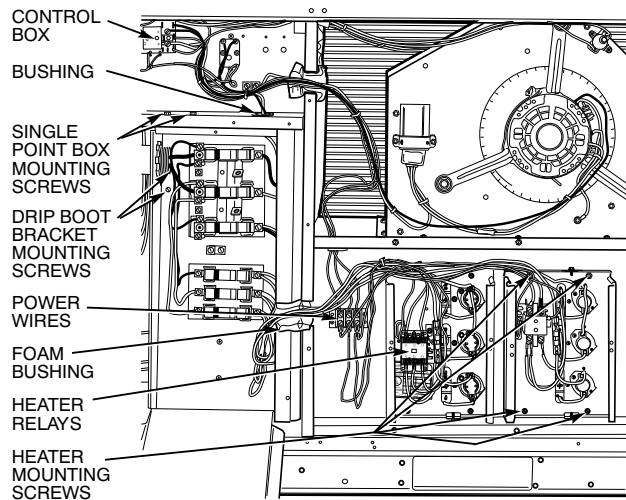

C14253

Fig. 40 - Typical Single Point Installation

Heater and Supplementary Fuses —

When the unit MOCP device value exceeds 60-A, unit-mounted supplementary fuses are required for each heater circuit. These fuses are included in accessory Single Point Boxes, with power distribution and fuse blocks.

All fuses on 50HCQ units are 60-A. (Note that all heaters are qualified for use with a 60-A fuse, regardless of actual heater ampacity, so only 60-A fuses are necessary.)

Heater Low-Voltage Control Connections —

One or two heaters can be installed in the unit. Use the wiring procedure listed below for each heater as determined by the number of stages in the heater.

Single Stage Heaters: Single-stage heaters will have an orange and a brown control wire. Connect these to the orange and brown wires located on TB4.

Two Stage Heaters: Two-stage heaters will have orange, purple, red and brown wires. The orange and the purple are the control wires and the red and brown wires feed the safety circuit. Connect both the orange and the purple wires to the orange wire locations of TB4. Connect the red and brown wires to red and brown wires on TB4. If more than one heater is installed, repeat the wiring procedure for the second heater. The 3 locations across the top of TB4 do allow a switch to be installed in series with some of the heaters in order to add additional heater control.

See Fig. 41 (on page 25) for additional details.

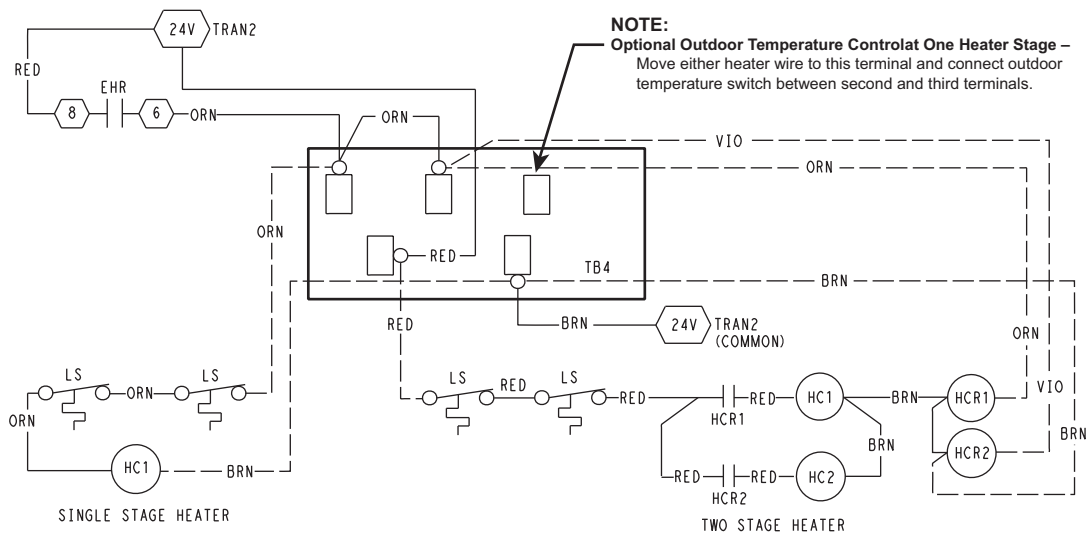

Fig. 41 - Accessory Electric Heater Control Connections

a50-9995

EconoMi\$er® X (Factory-Installed Option)



C14154

Fig. 42 - W7220 Economizer Module

Product Description —

The EconoMi\$er X system is an expandable economizer control system, which includes a W7220 economizer module (controller) with an LCD and keypad. The W7220 can be configured with optional sensors.

The W7220 economizer module can be used as a stand-alone economizer module wired directly to a commercial set-back space thermostat and sensors to provide outside air dry-bulb economizer control.

The W7220 economizer module can be connected to optional sensors for single or differential enthalpy control. The W7220 economizer module provides power and communications for the sensors.

The W7220 economizer module automatically detects sensors by polling to determine which sensors are present. If a sensor loses communications after it has been detected, the W7220 economizer controller indicates a device fail error on its LCD.

System Components —

The EconoMi\$er X system includes an economizer module, 20k mixed air sensor, damper actuator, and either a 20k outdoor air temperature sensor or S-Bus enthalpy sensors.

Economizer Module: This is the core of the EconoMi\$er X system, is mounted in the unit's control box, and includes the user interface for the system. The W7220 economizer module provides the basic inputs and outputs to provide simple economizer control. When used with the optional sensors, the economizer module provides more advanced economizer functionality.

S-Bus Enthalpy Control Sensors: The S-Bus enthalpy control sensor is a combination temperature and humidity sensor which is powered by and communicates on the S-Bus. Up to three sensors may be configured with the W7220 economizer module. See S-Bus Sensor Wiring on page 27 for details.

CO₂ Sensor (optional): A CO₂ sensor can be added for Demand Controlled Ventilation (DCV).

Specifications

W7220 Economizer Module —

The module is designed for use with 2 to 10 Vdc or bus communicating actuator. The module includes terminals for CO₂ sensor, mixed air sensor, and an outdoor dry bulb sensor. Enthalpy and other options are available with bus sensors.

User Interface: Provides status for normal operation, setup parameters, checkout tests, and alarm and error conditions with a 2-line 16 character LCD display and four button keypad.

Electrical —

Rated Voltage: 20 to 30 Vac RMS, 50/60 Hz
 Transformer: 100 va maximum system input

Nominal Power Consumption (at 24 Vac, 60 Hz):
 11.5 VA without sensors or actuators

Relay Digital Output Rating at 30 Vac (maximum power from Class 2 input only): 1.5A run:
 3.5A inrush at 0.45PF (200,000 cycles) or
 7.5A inrush at 0.45PF (100,000 cycles)

External Sensors Power Output: 21 Vdc ± 5% at 48mA

IMPORTANT: All inputs and outputs must be Class 2 wiring.

Inputs —

Sensors:

NOTE: A mixed air (MA) analog sensor is required on all W7220 units; either an outdoor air (OA) sensor for dry bulb change over or an OA bus sensor for outdoor enthalpy change over is required in addition to the MA sensor. An additional return air (RA) bus sensor can be added to the system for differential enthalpy or dry bulb changeover. For differential dry bulb changeover a 20k ohm sensor is required in the OA and a bus sensor in the RA. DIP switch on RA bus sensor must be set in the RA position.

Dry Bulb Temperature (optional) and Mixed Air (required), 20k NTC:
 2-wire (18 to 22 AWG);
 Temperature range -40 to 150°F (-40 to 65°C).
 Temperature accuracy -0°F/+2°F

Temperature and Humidity, C7400S1000 (optional):
 S-Bus; 2-wire (18 to 22 AWG)
 Temperature: range -40 to 150°F (-40 to 65°C)
 Temperature accuracy -0°F/+2°F
 Humidity: range 0 to 100% RH with 5% accuracy.

NOTE: Up to three (3) S-Bus sensors may be connected to the W7220 economizer module. For outdoor air (OA), return air (RA) and discharge (supply) air (DA).

4 Binary inputs:

1-wire 24 Vac + common GND (see Fig. 45 on page 27 for wiring details). 24 Vac power supply: 20 to 30 Vac 50/60Hz; 100 VA Class 2 transformer.

Outputs —

Actuator signal: 2-10 Vdc; minimum actuator impedance is 2k ohm; bus two-wire output for bus communicating actuators.

Exhaust fan, Y1, Y2 and AUX1 O:

All Relay Outputs (at 30 Vac):
 Running: 1.5A maximum
 Inrush: 7.5A maximum

Environmental —

Operating Temperature: -40 to 150°F (-40 to 65°C).
 Exception of display operation down to -4°F with full recovery at -4°F from exposure to -40°F

Storage Temperature: -40 to 150°F (-40 to 65°C)

Shipping Temperature: -40 to 150°F (-40 to 65°C)

Relative Humidity: 5% to 95% RH non-condensing

Economizer Module Wiring Details —

Use Fig. 43 and Tables 7 and 8 to locate the wiring terminals for the economizer module.

NOTE: The four terminal blocks are removable. You can slide out each terminal block, wire it, and then slide it back into place.

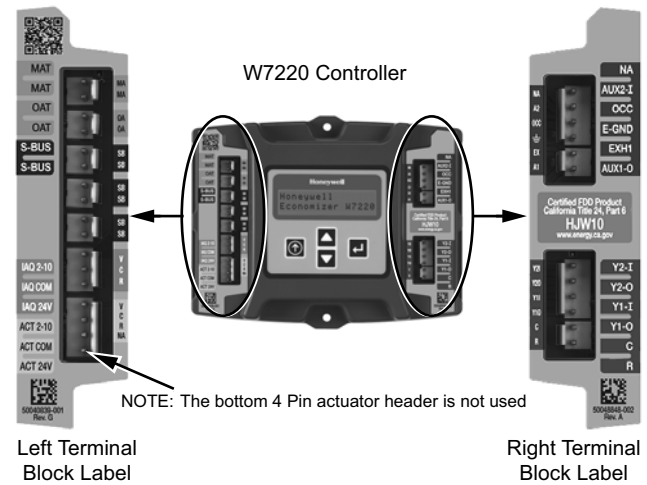

Fig. 43 - W7220 Economizer Module Terminal Connection Labels

Table 7 – Economizer Module - Left Hand Terminal Blocks

| Label | Type | Description |
|-----------------------------------|-------------------|--|
| Top Left Terminal Block | | |
| MAT MAT | 20k NTC and COM | Supply Air Temperature Sensor (polarity insensitive connection) |
| OAT OAT | 20k NTC and COM | Outdoor Air Temperature Sensor (polarity insensitive connection) |
| S-BUS S-BUS | S-Bus (Sylk* Bus) | Enthalpy Control Sensor (polarity insensitive connection) |
| Bottom Left Terminal Block | | |
| IAQ 2-10 | 2-10 Vdc | Air Quality Sensor Input (e.g. CO ₂ sensor) |
| IAQ COM | COM | Air Quality Sensor Common |
| IAQ 24V | 24 Vac | Air Quality Sensor 24 Vac Source |
| ACT 2-10 | 2-10 Vdc | Damper Actuator Output (2-10 Vdc) |
| ACT COM | COM | Damper Actuator Output Common |
| ACT 24V | 24 Vac | Damper Actuator 24 Vac Source |
| | n/a | The bottom pin is not used. |

* Sylk is a trademark of Honeywell International Inc.

**Table 8 – Economizer Module -
Right Hand Terminal Blocks**

| Label | Type | Description |
|------------------------------------|------------|---|
| Top Right Terminal Block | | |
| | n/a | The first pin is not used |
| AUX2 I | 24 Vac IN | Shut Down (SD) or Heat (W) Conventional only or Heat Pump Changeover (O/B) in Heat Pump mode. |
| OCC | 24 Vac IN | Occupied / Unoccupied Input |
| E-GND | E-GND | Earth Ground – System Required |
| EXH1 | 24 Vac OUT | Exhaust Fan 1 Output |
| AUX1 O | 24 Vac OUT | Programmable: Exhaust fan 2 output or ERV or System Alarm output |
| Bottom Right Terminal Block | | |
| Y2-I | 24 Vac IN | Y2 in – Cooling Stage 2 Input from space thermostat |
| Y2-O | 24 Vac OUT | Y2 out – Cooling Stage 2 Output to stage 2 mechanical cooling |
| Y1-I | 24 Vac IN | Y1 in – Cooling Stage 1 Input from space thermostat |
| Y1-O | 24 Vac OUT | Y1 out – Cooling Stage 1 Output to stage 1 mechanical cooling |
| C | COM | 24 Vac Common |
| R | 24 Vac | 24 Vac Power (Hot) |

S-Bus Sensor Wiring —

The labels on the sensors and controller are color coded for ease of installation. Orange labeled sensors can only be wired to orange terminals on the controller. Brown labeled sensors can only be wired to S-Bus (brown) terminals. Use Fig. 44 and Table 9 to locate the wiring terminals for each S-Bus sensor.

Table 9 – Enthalpy Control Sensor Wiring Terminations*

| Terminal | | Type | Description |
|----------|-------|-------|--|
| Nbr | Label | | |
| 1 | S-BUS | S-BUS | S-Bus Communications (Enthalpy Control Sensor Bus) |
| 2 | S-BUS | S-BUS | S-Bus Communications (Enthalpy Control Sensor Bus) |

* Terminals are polarity insensitive.

Table 10 – Enthalpy Control Sensor DIP Switch Settings

| Use | DIP Switch Positions for Switches 1, 2, and 3 | | |
|------|---|-----|-----|
| | 1 | 2 | 3 |
| DA* | OFF | ON | OFF |
| RA† | ON | OFF | OFF |
| OA** | OFF | OFF | OFF |

* DA = Discharge Air
† RA = Return Air
** OA = Outside Air

Use Fig. 44 and Table 10 to set the DIP switches for the desired use of the sensor.

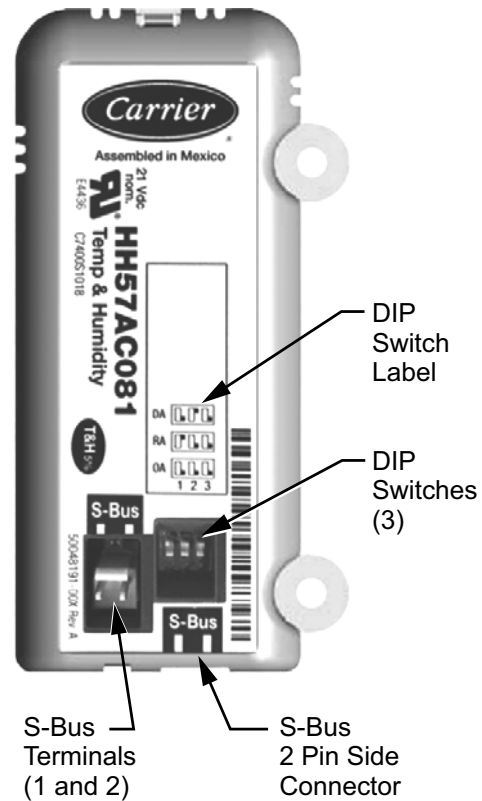

Fig. 44 - S-Bus Sensor DIP Switches

C14157

NOTE: When a S-Bus sensor is connected to an existing network, it will take 60 minutes for the network to recognize and auto-configure itself to use the new sensor. During the 60 minute setup period, no alarms for sensor failures (except SAT) will be issued and no economizing function will be available.

CO₂ Sensor Wiring —

When using a CO₂ sensor the black and brown common wires are internally connected and only one is connected to “IAQ COM” on the W7220. Use the power from the W7220 to power the CO₂ sensor OR make sure the ground for the power supplies are common. See Fig. 45 for CO₂ sensor wiring.

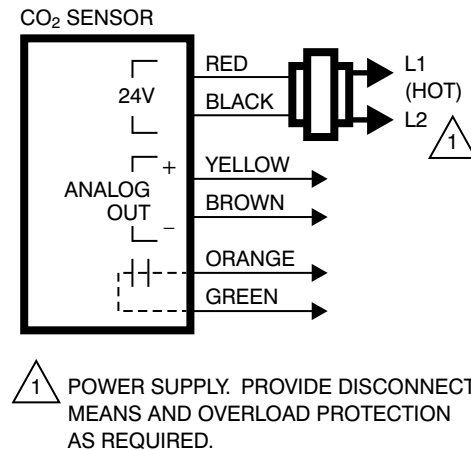

1 POWER SUPPLY. PROVIDE DISCONNECT MEANS AND OVERLOAD PROTECTION AS REQUIRED.

Fig. 45 - Wiring for CO₂ Sensor

C14158

Interface Overview

This section describes how to use the economizer's user interface for:

- Keypad and menu navigation
- Settings and parameter changes
- Menu structure and selection

User Interface —

The user interface consists of a 2-line LCD display and a 4-button keypad on the front of the economizer controller.

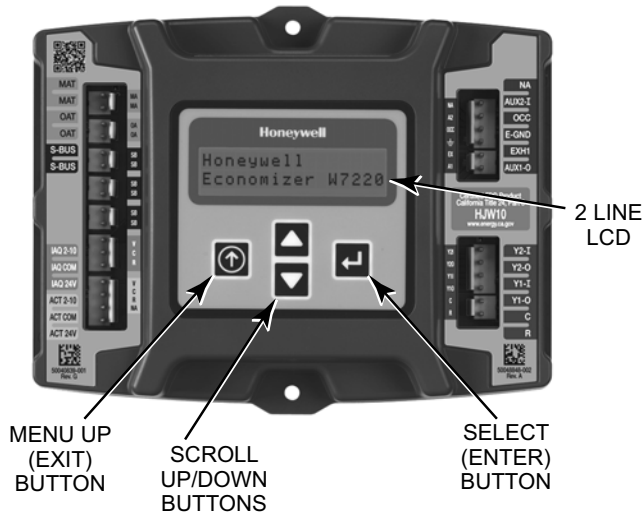

Fig. 46 - W7220 Controller

C14206

Keypad —

The four navigation buttons (see Fig. 46) are used to scroll through the menus and menu items, select menu items, and to change parameter and configuration settings.

To use the keypad when working with menus:

- Press the ▲ (Up arrow) button to move to the previous menu.
- Press the ▼ (Down arrow) button to move to the next menu.
- Press the ↵ (Enter) button to display the first item in the currently displayed menu.
- Press the ⏪ (Menu Up/Exit) button to exit a menu's item and return to the list of menus.

To use the keypad when working with Setpoints, System and Advanced Settings, Checkout tests and Alarms:

1. Navigate to the desired menu.
2. Press the ↵ (Enter) button to display the first item in the currently displayed menu.
3. Use the ▲ and ▼ buttons to scroll to the desired parameter.
4. Press the ↵ (Enter) button to display the value of the currently displayed item.
5. Press the ▲ button to increase (change) the displayed parameter value.

6. Press the ▼ button to decrease (change) the displayed parameter value.

NOTE: When values are displayed, pressing and holding the ▲ or ▼ button causes the display to automatically increment.

7. Press the ↵ (Enter) button to accept the displayed value and store it in nonvolatile RAM.
8. "CHANGE STORED" displays.
9. Press the ↵ (Enter) button to return to the current menu parameter.
10. Press the ⏪ (Menu Up/Exit) button to return to the previous menu.

Menu Structure

Table 11 illustrates the complete hierarchy of menus and parameters for the EconoMiSer® X system.

The Menus in display order are:

- STATUS
- SETPOINTS
- SYSTEM SETUP
- ADVANCED SETUP
- CHECKOUT
- ALARMS

IMPORTANT: Table 11 illustrates the complete hierarchy. Your menu parameters may be different depending on your configuration.

For example if you do not have a DCV (CO₂) sensor, then none of the DCV parameters appear and only MIN POS will display. If you have a CO₂ sensor, the DCV MIN and DCV MAX will appear AND if you have 2 speed fan DCV MIN (high and low speed) and DCV MAX (high and low speed will appear).

NOTE: Some parameters in the menu use the letters MA or MAT, indicating a mixed air temperature sensor location before the cooling coil. This unit application has the control sensor located after the cooling coil, in the fan section, where it is designated as (Cooling) Supply Air Temperature or SAT sensor.

Setup and Configuration

Before being placed into service, the W7220 economizer module must be setup and configured for the installed system.

IMPORTANT: During setup, the economizer module is live at all times.

The setup process uses a hierarchical menu structure that is easy to use. You press the ▲ and ▼ arrow buttons to move forward and backward through the menus and press the ↵ button to select and confirm setup item changes.

Time-out and Screensaver —

When no buttons have been pressed for 10 minutes, the LCD displays a screen saver, which cycles through the Status items. Each Status items displays in turn and cycles to the next item after 5 seconds.

Table 11 – Menu Structure*

| Menu | Parameter | Parameter Default Value | Parameter Range and Increment † | EXPANDED PARAMETER NAME Notes |
|----------|--------------|-------------------------|---|---|
| STATUS | ECON AVAIL | NO | YES/NO | ECONOMIZING AVAILABLE YES = economizing available; the system can use outside air for free cooling when required |
| | ECONOMIZING | NO | YES/NO | ECONOMIZING ACTIVE YES = Outside air being used for first stage cooling. NO = Economizing not active |
| | OCCUPIED | NO | YES/NO | OCCUPIED YES = OCC signal received from space thermostat or unitary controller. YES = 24 Vac on terminal OCC. NO = 0 Vac on terminal OCC. |
| | HEAT PUMP | n/a** | COOL HEAT | HEAT PUMP MODE Displays COOL or HEAT when system is set to heat pump (non-conventional) |
| | COOL Y1 –IN | OFF | ON/OFF | FIRST STAGE COOLING DEMAND (Y1 –IN) Y1 –I signal from space thermostat or unitary controller for Cooling Stage 1. ON = 24 Vac on terminal Y1 –I OFF = 0 Vac on terminal Y1 –I |
| | COOL Y1 –OUT | OFF | ON/OFF | FIRST STAGE COOLING RELAY OUTPUT Cool Stage 1 Relay Output to mechanical cooling (Y1 –OUT terminal). |
| | COOL Y2 –IN | OFF | ON/OFF | SECOND STAGE COOLING DEMAND (Y2 –IN) Y2 –I signal from space thermostat or unitary controller for Cooling Stage 2. ON = 24 Vac on terminal Y2 –I OFF = 0 Vac on terminal Y2 –I |
| | COOL Y2 –OUT | OFF | ON/OFF | SECOND STAGE COOLING RELAY OUTPUT Cool Stage 2 Relay Output to mechanical cooling (Y2 –OUT terminal). |
| | MA TEMP | ___ °F (or ___ °C) | –40 to 150 °F (–18 to 60 °C) | SUPPLY AIR TEMPERATURE, Cooling Mode Displays value of measured mixed/cooled air from SAT sensor in fan section. Displays --- if not connected, short or out-of-range. See Menu Note 2 |
| | DA TEMP | ___ °F (or ___ °C) | –40 to 150 °F (–18 to 60 °C) | DISCHARGE AIR TEMPERATURE, after Heating section (Accessory sensor required) Displays when Discharge Air sensor is connected and displays measured discharge temperature. Displays --- °F if sensor sends invalid value, if not connected, short or out-of-range. |
| | OA TEMP | ___ °F (or ___ °C) | –40 to 140 °F (–40 to 60 °C) | OUTSIDE AIR TEMPERATURE Displays measured value of outdoor air temperature. Displays --- °F if sensor sends invalid value, if not connected, short or out-of-range. |
| | OA HUM | __% | 0 to 100% | OUTSIDE AIR RELATIVE HUMIDITY Displays measured value of outdoor humidity from OA enthalpy sensor. |
| | RA TEMP | ___ °F (or ___ °C) | 0 to 140 °F (–18 to 60 °C) | RETURN AIR TEMPERATURE (Accessory sensor required) Displays measured value of return air temperature from RAT sensor. Displays --- °F if sensor sends invalid value, if not connected, short or out-of-range. |
| | RA HUM | __% | 0 to 100% | RETURN AIR RELATIVE HUMIDITY (Accessory enthalpy sensor required) Displays measured value of return air humidity from RA sensor. Displays ---% if sensor sends invalid value, if not connected, short or out-of-range. |
| | IN CO2 | ___ ppm | 0 to 2000 ppm | SPACE/RETURN AIR CO2 (CO ₂ sensor required, accessory or factory option) Displays value of measured CO ₂ from CO ₂ sensor. Invalid if not connected, short or out-of-range. May be adjusted in Advanced menu by Zero offset and Span. |
| | DCV STATUS | n/a | ON/OFF | DEMAND CONTROLLED VENTILATION STATUS (CO ₂ sensor required, accessory or factory option) Displays ON if IN CO2 value above setpoint DCV SET and OFF if below setpoint DCV SET. |
| | DAMPER OUT | 2.0V | 2.0 to 10.0V | Displays output voltage or position to the damper actuator. *** |
| | ACT POS | n/a | 0 to 100% | Displays actual position of outdoor air damper actuator |
| | ACT COUNT | n/a | 1 to 65535 | Displays number of times actuator has cycled. 1 Cycle equals accrued 180° of actuator movement in any direction |
| | ACTUATOR | n/a | OK/Alarm (on Alarm menu) | Displays Error if voltage or torque is below actuator range |
| EXH1 OUT | OFF | ON/OFF | EXHAUST STAGE 1 RELAY OUTPUT Output of EXH1 terminal. Displays On when damper position reaches programmed percentage setpoint. ON = 24 Vac Output; OFF = No Output. | |

Table 11 - Menu Structure * (cont)

| Menu | Parameter | Parameter Default Value | Parameter Range and Increment † | EXPANDED PARAMETER NAME Notes |
|---|--------------------------------------|---|---|--|
| STATUS (cont) | EXH2 OUT | OFF | ON/OFF | EXHAUST STAGE 2 RELAY OUTPUT Output of AUX1 O terminal Displays ON when damper position reaches programmed percentage setpoint ON = 24 Vac Output, OFF = No Output; displays only if AUX1 O = EXH2 |
| | ERV | OFF | ON/OFF | ENERGY RECOVERY UNIT RELAY OUTPUT Output of AUX1 O terminal, ON = 24 Vac Output, OFF = No Output; displays only if AUX1 O = ERV |
| | MECH COOL ON or HEAT STAGES ON | 0 | 0, 1, or 2 | Displays stage of mechanical cooling that is active. Displays the stage of heat pump heating that is active |
| | FAN SPEED | n/a | LOW or HIGH | SUPPLY FAN SPEED Displays speed setting of fan on a 2–speed fan unit. |
| | W (HEAT ON) | n/a | ON/OFF | HEAT DEMAND STATUS Displays status of heat demand on a 2–speed fan unit. |
| SETPOINTS | MAT SET | 53°F (12°C) | 38 to 70°F; (3 to 21°C) increment by 1 | SUPPLY AIR SETPOINT Setpoint determines where the economizer will modulate the OA damper to maintain the mixed air temperature. See Menu Note 2. |
| | LOW T LOCK | 32°F (0°C) | –45 to 80°F; (–43 to 27°C) increment by 1 | COMPRESSOR LOW TEMPERATURE LOCKOUT Setpoint determines outdoor temperature when the mechanical cooling cannot be turned on. Commonly referred to as the Compressor lockout. At or below the setpoint the Y1–O and Y2–O will not be energized on the controller. |
| | DRYBLB SET | 63°F (17°C) | 48 to 80°F (9 to 27°C) increment by 1 | OA DRY BULB TEMPERATURE CHANGEOVER SETPOINT Setpoint determines where the economizer will assume outdoor air temperature is good for free cooling; e.g.: at 63°F (17°C), unit will economize at 62°F (16.7°C) and below and not economize at 64°F (17.8°C) and above. There is a 2°F (1.1°C) deadband. See Menu Note 3 |
| | ENTH CURVE | ES3 | ES1, ES2, ES3, ES4, or ES5 | ENTHALPY CHANGEOVER CURVE (Requires enthalpy sensor option) Enthalpy boundary “curves” for economizing using single enthalpy. See page 37 for description of enthalpy curves. |
| | DCV SET | 1100ppm | 500 to 2000 ppm; increment by 100 | DEMAND CONTROLLED VENTILATION SETPOINT Displays only if CO ₂ sensor is connected. Setpoint for Demand Controlled Ventilation of space. Above the setpoint, the OA dampers will modulate open to bring in additional OA to maintain a space ppm level below the setpoint. |
| | MIN POS | 2.8 V | 2 to 10 Vdc | VENTILATION MINIMUM POSITION Displays ONLY if a CO ₂ sensor is NOT connected. |
| | | | | With 2–speed fan units MIN POS L (low speed fan) and MIN POS H (high speed fan) settings are required. Default for MIN POS L is 3.2V and MIN POS H is 2.8V. |
| | | | | DCV MAXIMUM DAMPER POSITION Displays only if a CO ₂ sensor is connected. Used for Vbz (ventilation max cfm) setpoint. VENTMAX is the same setting as MIN POS would be if you did not have the CO ₂ sensor. |
| | VENTMAX | 2.8 V | 2 to 10 Vdc | If OA, MA RA and CO ₂ sensors are connected and DCV CAL ENABLE is set to AUTO mode, the OA dampers are controlled by CFM and displays from 100 to 9990 cfm. |
| | | | | 100 to 9990 cfm increment by 10 |
| | | | | 2 to 10 Vdc With 2–speed fan units VENTMAX L (low speed fan) and VENTMAX H (high speed fan) settings are required. Default for VENTMAX L is 3.2V and VENTMAX H is 2.8V. |
| | VENTMIN | 2.25 V | 2 to 10 Vdc | DCV MINIMUM DAMPER POSITION Displays only if CO ₂ sensor is connected. Used for Va (ventilation min cfm) setpoint. This is the ventilation requirement for less than maximum occupancy of the space. |
| | | | | 100 to 9990 cfm increment by 10 |
| 2 to 10 Vdc With 2–speed fan units VENTMIN L (low speed fan) and VENTMIN H (high speed fan) settings are required. Default for VENTMIN L is 2.5V and VENTMIN H is 2.25V. | | | | |
| ERV OAT SP ^{††} | 32°F (0°C) | 0 to 50°F; (–18 to 10°C) increment by 1 | ENERGY RECOVERY VENTILATION UNIT OUTDOOR AIR TEMPERATURE SETPOINT Only when AUX1 O = ERV | |

Table 11 - Menu Structure* (cont)

| Menu | Parameter | Parameter Default Value | Parameter Range and Increment † | EXPANDED PARAMETER NAME Notes |
|-------------------------|-----------------|-------------------------|--|--|
| SETPOINTS (cont) | EXH1 SET | 50% | 0 to 100%; Increment by 1 | EXHAUST FAN STAGE 1 SETPOINT Setpoint for OA damper position when exhaust fan 1 is powered by the economizer. With 2-speed fan units Exh1 L (low speed fan) and Exh1 H (high speed fan) settings are required. Default for Exh1 L is 65% and Exh1 H is 50% |
| | EXH2 SET | 75% | 0 to 100%; Increment by 1 | EXHAUST FAN STAGE 2 SETPOINT Setpoint for OA damper position when exhaust fan 2 is powered by the economizer. Only used when AUX1 O is set to EXH2. With 2-speed fan units Exh2 L (low speed fan) and Exh2 H (high speed fan) settings are required. Default for Exh2 L is 80% and Exh2 H is 75% |
| SYSTEM SETUP | INSTALL | 01/01/10 | | Display order = MM/DD/YY Setting order = DD, MM, then YY. |
| | UNITS DEG | °F | °F or °C | Sets economizer controller in degrees Fahrenheit or Celsius. |
| | EQUIPMENT | CONV | Conventional or HP | CONV = conventional; HP O/B = Enable Heat Pump mode. Use AUX2 I for Heat Pump input from thermostat or controller. See Menu Note 4 |
| | AUX2 IN | n/a | Shutdown (SD) Heat (W1) HP (O) HP (B) | In CONV mode: SD = Enables configuration of shutdown (default); W = Informs controller that system is in heating mode. NOTE: If using 2-speed fan mode, you must program CONV mode for W. Shutdown is not available in 2-speed fan mode. See Menu Note 4. In HP O/B mode: HP(O) = energize heat pump on Cool (default); HP(B) = energize heat pump on Heat. |
| | FAN SPEED | 1speed | 1 speed/ 2 speed | Sets economizer controller for operation of 1 speed or 2 speed supply fan. The controller does not control the fan but positions the OA and RA dampers to the heating or cooling mode. See page 33 for modes and position. NOTE: 2-speed fan option also needs Heat (W1) programmed in AUX 2 In. See Menu Note 4. |
| | FAN CFM | 5000cfm | 100 to 15000 cfm; increment by 100 | UNIT DESIGN AIRFLOW (CFM) Enter ONLY if using DCVCAL ENA = AUTO The value is found the nameplate label for the specific RTU. |
| | AUX1 OUT | NONE | NONE ERV EXH2 SYS | Select OUTPUT for AUX1 O relay NONE = not configured (output is not used) ERV = Energy Recovery Ventilator †† EXH2 = second damper position 24 Vac out for second exhaust fan SYS = use output as an alarm signal |
| | OCC | INPUT | INPUT or ALWAYS | OCCUPIED MODE BY EXTERNAL SIGNAL When using a setback thermostat with occupancy out (24 Vac), the 24 Vac is input "INPUT" to the OCC terminal. If no occupancy output from the thermostat then change program to "ALWAYS" OR add a jumper from terminal R to OCC terminal. See Menu Note 1. |
| | FACTORY DEFAULT | NO | NO or YES | Resets all set points to factory defaults when set to YES. LCD will briefly flash YES and change to NO but all parameters will change to the factory default values. NOTE: RECHECK AUX2 IN and FANTYPE for required 2-speed values. |
| | INSTALL | 01/01/10 | | Display order = MM/DD/YY Setting order = DD, MM, then YY. |
| | UNITS DEG | °F | °F or °C | Sets economizer controller in degrees Fahrenheit or Celsius. |
| | EQUIPMENT | CONV | Conventional or HP | CONV = conventional; HP O/B = Enable Heat Pump mode. Use AUX2 I for Heat Pump input from thermostat or controller. See Menu Note 4 |
| | AUX2 IN | n/a | Shutdown (SD) Heat (W1) HP (O) HP (B) | In CONV mode: SD = Enables configuration of shutdown (default); W = Informs controller that system is in heating mode. NOTE: If using 2-speed fan mode, you must program CONV mode for W. Shutdown is not available in 2-speed fan mode. See Menu Note 4. In HP O/B mode: HP(O) = energize heat pump on Cool (default); HP(B) = energize heat pump on Heat. |
| | FAN SPEED | 1speed | 1 speed/ 2 speed | Sets economizer controller for operation of 1 speed or 2 speed supply fan. The controller does not control the fan but positions the OA and RA dampers to the heating or cooling mode. See page 33 for modes and position. NOTE: 2-speed fan option also needs Heat (W1) programmed in AUX 2 In. See Menu Note 4. |

Table 11 - Menu Structure* (cont)

| Menu | Parameter | Parameter Default Value | Parameter Range and Increment† | EXPANDED PARAMETER NAME Notes |
|----------------------------|-----------------|---|--|--|
| SYSTEM SETUP (cont) | FAN CFM | 5000cfm | 100 to 15000 cfm; increment by 100 | UNIT DESIGN AIRFLOW (CFM) Enter ONLY if using DCV CAL ENA = AUTO The value is found the nameplate label for the specific RTU. |
| | AUX1 OUT | NONE | NONE ERV EXH2 SYS | Select OUTPUT for AUX1 O relay NONE = not configured (output is not used) ERV = Energy Recovery Ventilator †† EXH2 = second damper position 24 Vac out for second exhaust fan SYS = use output as an alarm signal |
| | OCC | INPUT | INPUT or ALWAYS | OCCUPIED MODE BY EXTERNAL SIGNAL When using a setback thermostat with occupancy out (24 Vac), the 24 Vac is input "INPUT" to the OCC terminal. If no occupancy output from the thermostat then change program to "ALWAYS" OR add a jumper from terminal R to OCC terminal. See Menu Note 1. |
| | FACTORY DEFAULT | NO | NO or YES | Resets all set points to factory defaults when set to YES. LCD will briefly flash YES and change to NO but all parameters will change to the factory default values. NOTE: RECHECK AUX2 IN and FANTYPE for required 2–speed values. |
| ADVANCED SETUP | MA LO SET | 45°F (7°C) | 35 to 65°F; (2 to 18°C) Incremented by 1° | SUPPLY AIR TEMPERATURE LOW LIMIT Temperature to activate Freeze Protection (close damper and alarm if temperature falls below setup value) |
| | FREEZE POS | CLO | CLO or MIN | FREEZE PROTECTION DAMPER POSITION Damper position when freeze protection is active CLO = closed MIN = MIN POS or VENTMAX |
| | CO2 ZERO | 0ppm | 0 to 500 ppm: Increment by 10 | CO ₂ ppm level to match CO ₂ sensor start level. |
| | CO2 SPAN | 2000ppm | 1000 to 3000 ppm; Increment by 50 | CO ₂ ppm span to match CO ₂ sensor. e.g.; 500–1500 sensor output would be 500 CO ₂ zero and 1000 CO ₂ span. |
| | STG3 DLY | 2.0h | 0 min, 5 min, 15 min, then 15 min intervals. Up to 4 h or OFF | COOLING STAGE 3 DELAY Delay after stage 2 for cool has been active. Turns on second stage of mechanical cooling when economizer is first stage call and mechanical cooling is second stage call. Allows three stages of cooling, 1 economizer and 2 mechanical. OFF = no Stage 3 cooling. |
| | SD DMPR POS | CLO | CLO or OPN | Indicates shutdown signal from space thermostat or unitary controller. When controller receives 24 Vac input on the SD terminal in conventional mode, the OA damper will open if programmed for OPN and OA damper will close if programmed for CLO. All other controls, e.g., Y1–O, Y2–O, EXH1, etc. will shut off. NOTE: Function NOT AVAILABLE with 2–speed mode |
| | DA LO ALM | 45°F (7°C) | NONE 35 to 65°F; (2 to 18°C) Incremented by 5° | Used for alarm for when the DA air temperature is too low. Set lower range of alarm, below this temperature the alarm will show on the display. |
| | DA HI ALM | 80°F (27°C) | NONE 70 to 180°F; (21 to 82°C) Incremented by 5° | Used for alarm for when the DA air temperature is too high. Set high range of alarm, above this temperature the alarm will show on the display |
| | DCV CAL ENA | MAN | MAN (manual) AUTO | Turns on the DCV automatic control of the dampers. Resets ventilation based on the RA, OA and MA sensor conditions. Requires all sensors (RA, OA, MA and CO ₂). NOTE: This operation is not operable with a 2–speed fan unit. |
| | OAS T CAL | 1.0°F (or C) | +/-2.5°F (+/-1.4°C) | OUTSIDE AIR TEMPERATURE CALIBRATION Allows for the operator to adjust for an out of calibration outside air temperature (OAT) sensor |
| | OAS H CAL | 0% RH | +/-10% RH | OUTSIDE AIR HUMIDITY CALIBRATION Allows for the operator to adjust for an out of outside air enthalpy sensor |
| | RA T CAL | 0.0°F (or C) | +/-2.5°F (+/-1.4°C) | RETURN AIR TEMPERATURE CALIBRATION Allows for the operator to adjust for an out of calibration return air temperature (RA) sensor |
| | RA H CAL | 0% RH | +/-10% RH | RETURN AIR HUMIDITY CALIBRATION Allows for the operator to adjust for an out of calibration return air enthalpy sensor |
| | DA T CAL | 0.0°F (or C) | +/-2.5°F (+/-1.4°C) | DISCHARGE AIR TEMPERATURE CALIBRATION Allows for the operator to adjust for an out of calibration discharge air temperature (DAT) sensor |
| 2SP FAN DELAY | 5 Minutes | 0 to 20 minutes in 1 minute increments | TIME DELAY ON 2 nd STAGE ECONOMIZING When in economizing mode this is the delay for the high speed fan to try to satisfy the call for second stage cooling before the first stage mechanical cooling is enabled. | |

Table 11 - Menu Structure* (cont)

| Menu | Parameter | Parameter Default Value | Parameter Range and Increment † | EXPANDED PARAMETER NAME Notes |
|-----------------|-------------------------|-------------------------|---|--|
| CHECKOUT ††† | DAMPER MINIMUM POSITION | n/a | n/a | The checkout for the damper minimum positions is based on the system. See Table 12. |
| | DAMPER OPEN | n/a | n/a | Positions damper to the full open position. Exhaust fan contacts enable during the DAMPER OPEN test. Make sure you pause in this mode to allow for exhaust contacts to energize due to the delay in the system. |
| | DAMPER CLOSE | n/a | n/a | Positions damper to the fully closed position |
| | CONNECT Y1–O | n/a | n/a | Closes the Y1–O relay (Y1–O). See CAUTION on page 39. |
| | CONNECT Y2–O | n/a | n/a | Closes the Y2–O relay (Y2–O) See CAUTION on page 39. |
| | CONNECT AUX1–O | n/a | n/a | Energizes the AUX1–O output. If AUX1–O setting is: <ul style="list-style-type: none"> • NONE – not action taken • ERV – 24 Vac out. Turns on or signals an ERV that the conditions are not good for economizing but are good for ERV operation. †† • SYS – 24 Vac out. Issues a system alarm. |
| | CONNECT EXH1 | n/a | n/a | Closes the power exhaust fan 1 relay (EXH1) |
| ALARMS(#) | | | | Alarms display only when they are active. The menu title “ALARMS(#)” includes the number of active alarms in parenthesis (). When using S–Bus sensors, “SYLK” will appear on the screen, and when using 20k OA temperature sensors, “SENS T” will appear on the screen. |
| | MA T SENS ERR | n/a | n/a | SUPPLY AIR TEMPERATURE SENSOR ERROR Supply air sensor has failed or become disconnected – check wiring then replace sensor if the alarm continues |
| | CO2 SENS ERR | n/a | n/a | CO ₂ SENSOR ERROR CO ₂ sensor has failed, gone out of range or become disconnected – check wiring then replace sensor if the alarm continues |
| | OA SYLK T ERR | n/a | n/a | OUTSIDE AIR S–BUS SENSOR ERROR |
| | OA SYLK H ERR | n/a | n/a | Outside air enthalpy sensor has failed or become disconnected – check wiring then replace sensor if the alarm continues |
| | RA SYLK T ERR | n/a | n/a | RETURN AIR S–BUS SENSOR ERROR |
| | RA SYLK H ERR | n/a | n/a | Return air enthalpy sensor has failed or become disconnected – check wiring then replace sensor if the alarm continues |
| | DA SYLK T ERR | n/a | n/a | DISCHARGE AIR S–BUS SENSOR ERROR |
| | | | | Discharge air sensor has failed or become disconnected – check wiring then replace sensor if the alarm continues |
| | OA SENS T ERR | n/a | n/a | OUTSIDE AIR TEMPERATURE SENSOR ERROR Outside air temperature sensor has failed or become disconnected – check wiring then replace sensor if the alarm continues |
| | ACT ERROR | n/a | n/a | ACTUATOR ERROR Actuator has failed or become disconnected – check for stall, over voltage, under voltage and actuator count. Replace actuator if damper is moveable and supply voltage is between 21.6 V and 26.4 V. Check actuator count on STATUS menu. |
| | FREEZE ALARM | n/a | n/a | Check if outdoor temperature is below the LOW Temp Lockout on setpoint menu. Check if Mixed air temperature on STATUS menu is below the Lo Setpoint on Advanced setup menu. When conditions are back in normal range then the alarm will go away. |
| | SHUTDOWN ACTIVE | n/a | n/a | AUX2 IN is programmed for SHUTDOWN and 24 V has been applied to AUX 2IN terminal |
| | DMP CAL RUNNING | n/a | n/a | DAMPER CALIBRATION ROUTINE RUNNING If DCV Auto enable has been programmed, when the W7220 is completing a calibration on the dampers, this alarm will display. Wait until the calibration is completed and the alarm will go away. Must have OA, MA and RA sensors for DCV calibration; set up is in the Advanced setup menu. |
| | DA SENS ALM | n/a | n/a | DISCHARGE AIR TEMPERATURE SENSOR ALARM Discharge air temperature is out of the range set in the ADVANCED SETUP Menu. Check the temperature of the discharge air. |
| | SYS ALARM | n/a | n/a | When AUX1–O is set to SYS and there is any alarm (e.g., failed sensors, etc.), the AUX1–O terminal has 24 Vac out. |
| | ACT UNDER V | n/a | n/a | ACTUATOR VOLTAGE LOW Voltage received at actuator is below expected range |
| ACT OVER V | n/a | n/a | ACTUATOR VOLTAGE HIGH Voltage received at actuator is above expected range | |
| ACT STALLED | n/a | n/a | ACTUATOR STALLED Actuator stopped before reaching commanded position | |

Table 11 - Menu Structure* (cont)

- * Table 11 illustrates the complete hierarchy. Your menu parameters may be different depending on your configuration. For example if you do not have a DCV (CO₂) sensor, then none of the DCV parameters appear.
- † When values are displayed, pressing and holding the ▲ or ▼ button causes the display to automatically increment.
- ** n/a = not applicable
- †† ERV Operation: When in Cooling mode AND the conditions are NOT OK for economizing – the ERV terminal will be energized. In the Heating mode the ERV terminal will be energized when the OA is below the ERV OAT setpoint in the setpoint menu.
- *** When used with communicating actuator the damper out is reported in XX.X% open verses XX.X Vdc.
- ††† After 10 minutes without a command or mode change, the controller will change to normal operation.

Menu Notes

- 1 **STATUS -> OCCUPIED** – The factory-standard Occupancy signal originates with a thermostat or other controller call for indoor fan operation at CTB terminal G. This signal passes through the Central Terminal Board's OCCUPIED jumper JMP1 to the ECONO connector and to the W7220's OCC input terminal. An external timeclock or relay is required to implement an Occupancy schedule on the economizer damper position.
- 2 **STATUS -> MA TEMP, SETPOINTS -> MAT SET** – The W7220 menu parameters and labels include designations MA, MAT and Mixed Air for the economizer cooling control sensor. On these rooftop units, the economizer control sensor is located downstream of the evaporator/indoor coil in the supply fan section where this sensor is designated as Supply Air Temperature (SAT) sensor.
- 3 **SETPOINTS -> DRYBLB SET** – This point is not displayed if a Return Air (differential) temperature sensor or an Outdoor Air enthalpy sensor is connected.
- 4 **SYSTEM SETUP** parameters must be configured as noted for 2-Speed unit operation:
EQUIPMENT = CONV
AUX2 IN = W
FAN SPEED = 2SPEED

Table 12 – Damper Minimum Position Settings and Readings on Checkout Menu

| Fan Speed | Demand Controlled Ventilation (CO ₂ Sensor) | Setpoints | Checkout |
|-----------|--|------------|-----------|
| 1 | NO | MIN POS | VMAX – HS |
| 1 | NO | N/A | N/A |
| 2 | NO | MIN POS H | VMAX – HS |
| 2 | NO | MIN POS L | VMAX – LS |
| 1 | YES | VENT MIN | VMIN – HS |
| 1 | YES | VENT MAX | VMAX – HS |
| 2 | YES | VENT MIN H | VMIN – HS |
| 2 | YES | VENT MAX H | VMAX – LS |
| 2 | YES | VENT MIN L | N/A |
| 2 | YES | VENT MAX L | N/A |

Sequence of Operation

Table 13 – Dry Bulb Operation No DCV (CO₂ Sensor) - 1 Speed Fan

| Demand Controlled Ventilation (DCV) | Outside Air – Good to economize? | Y1-I | Y2-I | Fan Speed | Y1-O | Y2-O | Occupied | Unoccupied |
|-------------------------------------|----------------------------------|------|------|-----------|---------|----------|----------------------|---------------------|
| None | No | Off | Off | High | 0-v/Off | 0-v/Off | MIN POS | Closed |
| | | On | Off | High | 24-v/On | 0-v/Off | MIN POS | Closed |
| | | On | On | High | 24-v/On | 24-v/On | MIN POS | Closed |
| None | Yes | Off | Off | High | 0-v/Off | 0-v/Off | MIN POS | Closed |
| | | On | Off | High | 0-v/Off | 0-v/Off | MIN POS to Full-Open | Closed to Full-Open |
| | | On | On | High | 24-v/On | 0-v/Off* | MIN POS to Full-Open | Closed to Full-Open |

* With stage 3 delay (STG3 DLY) in Advanced setup menu can turn on second stage of mechanical cooling Y2 –O after the delay if the call for Y1 –I and Y2 –I have not been satisfied.

Table 14 – Dry Bulb Operation With DCV (CO₂ Sensor) - 1 Speed Fan

| Demand Controlled Ventilation (DCV) | Outside Air – Good to economize? | Y1-I | Y2-I | Fan Speed | Y1-O | Y2-O | Occupied | Unoccupied |
|-------------------------------------|----------------------------------|------|------|-----------|---------|----------|----------------------|---------------------|
| Below CO ₂ set | No | Off | Off | High | 0-v/Off | 0-v/Off | VENTMIN | Closed |
| | | On | Off | High | 24-v/On | 0-v/Off | VENTMIN | Closed |
| | | On | On | High | 24-v/On | 24-v/On | VENTMIN | Closed |
| | Yes | Off | Off | High | 0-v/Off | 0-v/Off | VENTMIN | Closed |
| | | On | Off | High | 0-v/Off | 0-v/Off | VENTMIN to Full-Open | Closed to Full-Open |
| | | On | On | High | 24-v/On | 0-v/Off* | VENTMIN to Full-Open | Closed to Full-Open |
| Above CO ₂ set | No | Off | Off | High | 0-v/Off | 0-v/Off | VENTMIN to VENTMAX | Closed |
| | | On | Off | High | 24-v/On | 0-v/Off | VENTMIN to VENTMAX | Closed |
| | | On | On | High | 24-v/On | 24-v/On | VENTMIN to VENTMAX | Closed |
| | Yes | Off | Off | High | 0-v/Off | 0-v/Off | VENTMIN to VENTMAX | Closed |
| | | On | Off | High | 0-v/Off | 0-v/Off | VENTMIN to Full-Open | Closed to Full-Open |
| | | On | On | High | 24-v/On | 0-v/Off* | VENTMIN to Full-Open | Closed to Full-Open |

* With stage 3 delay (STG3 DLY) in Advanced setup menu can turn on second stage of mechanical cooling Y2 –O after the delay if the call for Y1 –I and Y2 –I have not been satisfied.

Table 15 – Enthalpy Operation No DCV (CO₂ Sensor) - 1 Speed Fan

| Demand Controlled Ventilation (DCV) | Outside Air – Good to economize? | Y1-I | Y2-I | Fan Speed | Y1-O | Y2-O | Occupied | Unoccupied |
|-------------------------------------|----------------------------------|------|------|-----------|---------|----------|----------------------|---------------------|
| None | No | Off | Off | High | 0-v/Off | 0-v/Off | MIN POS | Closed |
| | | On | Off | High | 24-v/On | 0-v/Off | MIN POS | Closed |
| | | On | On | High | 24-v/On | 24-v/On | MIN POS | Closed |
| None | Yes | Off | Off | High | 0-v/Off | 0-v/Off | MIN POS | Closed |
| | | On | Off | High | 0-v/Off | 0-v/Off | MIN POS to Full-Open | Closed to Full-Open |
| | | On | On | High | 24-v/On | 0-v/Off* | MIN POS to Full-Open | Closed to Full-Open |

* With stage 3 delay (STG3 DLY) in Advanced setup menu can turn on second stage of mechanical cooling Y2 –O after the delay if the call for Y1 –I and Y2 –I have not been satisfied.

Table 16 – Enthalpy Operation No DCV (CO₂ Sensor) - 1 Speed Fan

| Demand Controlled Ventilation (DCV) | Outside Air – Good to economize? | Y1-I | Y2-I | Fan Speed | Y1-O | Y2-O | Occupied | Unoccupied |
|-------------------------------------|----------------------------------|------|------|-----------|-------------------------------|----------|----------------------|---------------------|
| Below set | No | Off | Off | High | 0-v/Off | 0-v/Off | VENTMIN | Closed |
| | | On | Off | High | 24-v/On | 0-v/Off | VENTMIN | Closed |
| | | On | On | High | 24-v/On | 24-v/On | VENTMIN | Closed |
| | Yes | Off | Off | High | 0-v/Off | 0-v/Off | VENTMIN | Closed |
| | | On | Off | High | 0-v/Off | 0-v/Off | VENTMIN to Full-Open | Closed to Full-Open |
| | | On | On | High | 24-v/On | 0-v/Off* | VENTMIN to Full-Open | Closed to Full-Open |
| Above set | No | Off | Off | High | 0-v/Off | 0-v/Off | VENTMIN to VENTMAX | Closed |
| | | On | Off | High | 24-v/On | 0-v/Off | VENTMIN L to VENTMAX | Closed |
| | | On | On | High | 24-v/On | 24-v/On | VENTMIN H to VENTMAX | Closed |
| | Yes | Off | Off | High | 0-v/Off | 0-v/Off | VENTMIN L to VENTMAX | Closed |
| | | On | Off | High | 0-v/Off | 0-v/Off | VENTMIN to Full-Open | Closed to Full-Open |
| | | On | On | High | DELAY [†] 24-v/On | 0-v/Off* | VENTMIN to Full-Open | Closed to Full-Open |

* With stage 3 delay (STG3 DLY) in Advanced setup menu can turn on second stage of mechanical cooling Y2 –O after the delay if the call for Y1 –I and Y2 –I have not been satisfied.

† With 2SP FAN DELAY (Advanced Setup Menu) when in the economizing mode there is a delay for the high speed fan to try to satisfy the call for second stage cooling by turning on the fan to high and opening the OA damper 100% before the first stage mechanical cooling is enabled.

Table 17 – Dry Bulb Operation No DCV (CO₂ Sensor) - 2 Speed Fan

| Demand Controlled Ventilation (DCV) | Outside Air – Good to economize? | Y1-I | Y2-I | Fan Speed | Y1-O | Y2-O | Occupied | Unoccupied |
|-------------------------------------|----------------------------------|------|------|-----------|-------------------------------|----------|------------------------|---------------------|
| None | No | Off | Off | Low | 0-v/Off | 0-v/Off | MIN POS L | Closed |
| | | On | Off | Low | 24-v/On | 0-v/Off | MIN POS L | Closed |
| | | On | On | High | 24-v/On | 24-v/On | MIN POS H | Closed |
| None | Yes | Off | Off | Low | 0-v/Off | 0-v/Off | MIN POS L | Closed |
| | | On | Off | Low | 0-v/Off | 0-v/Off | MIN POS L to Full-Open | Closed to Full-Open |
| | | On | On | High | DELAY [†] 24-v/On | 0-v/Off* | MIN POS H to Full-Open | Closed to Full-Open |

* With stage 3 delay (STG3 DLY) in Advanced setup menu can turn on second stage of mechanical cooling Y2 –O after the delay if the call for Y1 –I and Y2 –I have not been satisfied.

† With 2SP FAN DELAY (Advanced Setup Menu) when in the economizing mode there is a delay for the high speed fan to try to satisfy the call for second stage cooling by turning on the fan to high and opening the OA damper 100% before the first stage mechanical cooling is enabled.

Table 18 – Dry Bulb Operation With DCV (CO₂ Sensor) - 2 Speed Fan

| Demand Controlled Ventilation (DCV) | Outside Air – Good to economize? | Y1-I | Y2-I | Fan Speed | Y1-O | Y2-O | Occupied | Unoccupied |
|-------------------------------------|----------------------------------|------|------|-----------|-------------------------------|----------|------------------------|---------------------|
| Below set | No | Off | Off | Low | 0-v/Off | 0-v/Off | VENTMIN L | Closed |
| | | On | Off | Low | 24-v/On | 0-v/Off | VENTMIN L | Closed |
| | | On | On | High | 24-v/On | 24-v/On | VENTMIN H | Closed |
| | Yes | Off | Off | Low | 0-v/Off | 0-v/Off | VENTMIN L | Closed |
| | | On | Off | Low | 0-v/Off | 0-v/Off | VENTMIN L to Full-Open | Closed to Full-Open |
| | | On | On | High | 24-v/On | 0-v/Off* | VENTMIN H to Full-Open | Closed to Full-Open |
| Above set | No | Off | Off | Low | 0-v/Off | 0-v/Off | VENTMIN L to VENTMAX | Closed |
| | | On | Off | Low | 24-v/On | 0-v/Off | VENTMIN L to VENTMAX | Closed |
| | | On | On | High | 24-v/On | 24-v/On | VENTMIN H to VENTMAX | Closed |
| | Yes | Off | Off | Low | 0-v/Off | 0-v/Off | VENTMIN L to VENTMAX | Closed |
| | | On | Off | Low | 0-v/Off | 0-v/Off | VENTMIN L to Full-Open | Closed to Full-Open |
| | | On | On | High | DELAY [†] 24-v/On | 0-v/Off* | VENTMIN H to Full-Open | Closed to Full-Open |

* With stage 3 delay (STG3 DLY) in Advanced setup menu can turn on second stage of mechanical cooling Y2 –O after the delay if the call for Y1 –I and Y2 –I have not been satisfied.

† With 2SP FAN DELAY (Advanced Setup Menu) when in the economizing mode there is a delay for the high speed fan to try to satisfy the call for second stage cooling by turning on the fan to high and opening the OA damper 100% before the first stage mechanical cooling is enabled.

Table 19 – Enthalpy Operation No DCV (CO₂ Sensor) - 2 Speed Fan

| Demand Controlled Ventilation (DCV) | Outside Air – Good to economize? | Y1-I | Y2-I | Fan Speed | Y1-O | Y2-O | Occupied | Unoccupied |
|-------------------------------------|----------------------------------|------|------|-----------|--------------------|----------|------------------------|---------------------|
| NO CO ₂ SENSOR | No | Off | Off | Low | 0-v/Off | 0-v/Off | MIN POS L | Closed |
| | | On | Off | Low | 24-v/On | 0-v/Off | MIN POS L | Closed |
| | | On | On | High | 24-v/On | 24-v/On | MIN POS H | Closed |
| | Yes | Off | Off | Low | 0-v/Off | 0-v/Off | MIN POS L | Closed |
| | | On | Off | Low | 0-v/Off | 0-v/Off | MIN POS L to Full-Open | Closed to Full-Open |
| | | On | On | High | DELAY † 24-v/On | 0-v/Off* | MIN POS H to Full-Open | Closed to Full-Open |

* With stage 3 delay (STG3 DLY) in Advanced setup menu can turn on second stage of mechanical cooling Y2 –O after the delay if the call for Y1 –I and Y2 –I have not been satisfied.

† With 2SP FAN DELAY (Advanced Setup Menu) when in the economizing mode there is a delay for the high speed fan to try to satisfy the call for second stage cooling by turning on the fan to high and opening the OA damper 100% before the first stage mechanical cooling is enabled.

Table 20 – Enthalpy Operation With DCV (CO₂ Sensor) - 2 Speed Fan

| Demand Controlled Ventilation (DCV) | Outside Air – Good to economize? | Y1-I | Y2-I | Fan Speed | Y1-O | Y2-O | Occupied | Unoccupied |
|-------------------------------------|----------------------------------|------|------|-----------|--------------------|----------|------------------------|---------------------|
| Below set | No | Off | Off | Low | 0-v/Off | 0-v/Off | VENTMIN L | Closed |
| | | On | Off | Low | 24-v/On | 0-v/Off | VENTMIN L | Closed |
| | | On | On | High | 24-v/On | 24-v/On | VENTMIN H | Closed |
| | Yes | Off | Off | Low | 0-v/Off | 0-v/Off | VENTMIN L | Closed |
| | | On | Off | Low | 0-v/Off | 0-v/Off | VENTMIN L to Full-Open | Closed to Full-Open |
| | | On | On | High | 24-v/On | 0-v/Off* | VENTMIN H to Full-Open | Closed to Full-Open |
| Above set | No | Off | Off | Low | 0-v/Off | 0-v/Off | VENTMIN L to VENTMAX | Closed |
| | | On | Off | Low | 24-v/On | 0-v/Off | VENTMIN L to VENTMAX | Closed |
| | | On | On | High | 24-v/On | 24-v/On | VENTMIN H to VENTMAX | Closed |
| | Yes | Off | Off | Low | 0-v/Off | 0-v/Off | VENTMIN L to VENTMAX | Closed |
| | | On | Off | Low | 0-v/Off | 0-v/Off | VENTMIN L to Full-Open | Closed to Full-Open |
| | | On | On | High | DELAY † 24-v/On | 0-v/Off* | VENTMIN H to Full-Open | Closed to Full-Open |

* With stage 3 delay (STG3 DLY) in Advanced setup menu can turn on second stage of mechanical cooling Y2 –O after the delay if the call for Y1 –I and Y2 –I have not been satisfied.

† With 2SP FAN DELAY (Advanced Setup Menu) when in the economizing mode there is a delay for the high speed fan to try to satisfy the call for second stage cooling by turning on the fan to high and opening the OA damper 100% before the first stage mechanical cooling is enabled.

Enthalpy Settings

When the OA temperature, enthalpy and dew point are below the respective setpoints, the outdoor air can be used for economizing. Fig. 47 shows the new single enthalpy boundaries in the W7220. There are 5 boundaries (setpoints ES1 through ES5), which are defined by dry bulb temperature, enthalpy and dew point.

Refer to Table 21 for ENTH CURVE setpoint values.

The W7220 calculates the enthalpy and dew point using the OA temperature and humidity input from the OA enthalpy sensor. When the OA temperature, OA humidity and OA dew point are all below the selected boundary, the economizer sets the economizing mode to YES, economizing is available.

When all of the OA conditions are above the selected boundary, the conditions are not good to economize and the mode is set to NO.

Fig. 47 shows the 5 current boundaries. There is also a high limit boundary for differential enthalpy. The high limit boundary is ES1 when there are no stages of mechanical cooling energized and HL (high limit) when a compressor stage is energized.

Table 21 provides the values for each boundary limit.

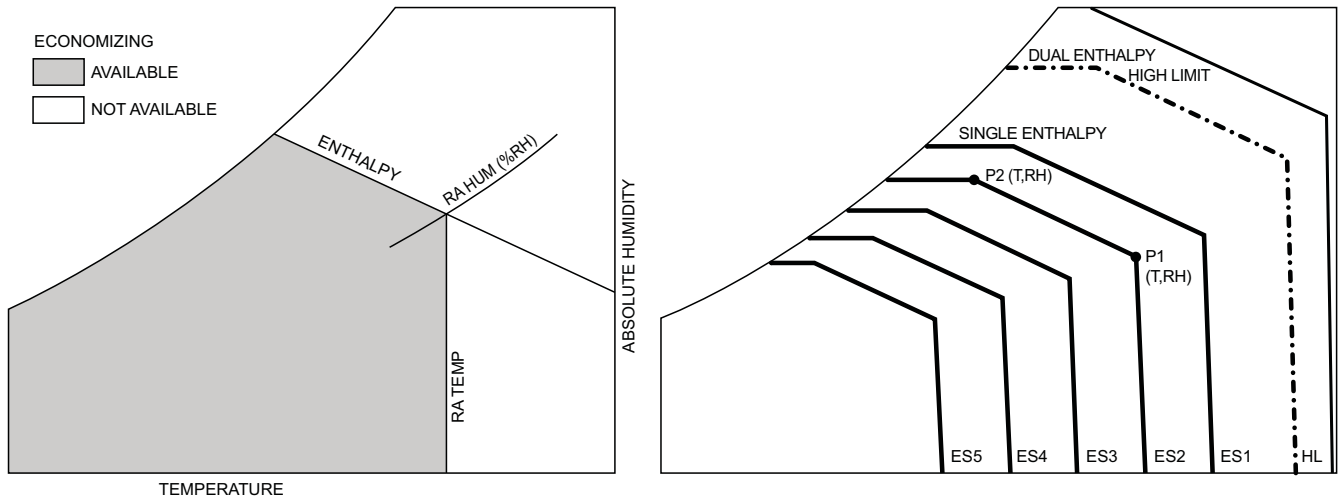

a50-9997

Fig. 47 - Single Enthalpy Curve and Boundaries

Table 21 – Single Enthalpy and Dual Enthalpy High Limit Curves (EN Units)

| Enthalpy Curve | Temp. Dry-Bulb (°F) | Temp. Dewpoint (°F) | Enthalpy (btu/lb/da) | Point P1 | | Point P2 | |
|----------------|---------------------|---------------------|----------------------|------------|--------------|------------|--------------|
| | | | | Temp. (°F) | Humidity %RH | Temp. (°F) | Humidity %RH |
| ES1 | 80.0 | 60.0 | 28.0 | 80.0 | 36.8 | 66.3 | 80.1 |
| ES2 | 75.0 | 57.0 | 26.0 | 75.0 | 39.6 | 63.3 | 80.0 |
| ES3 | 70.0 | 54.0 | 24.0 | 70.0 | 42.3 | 59.7 | 81.4 |
| ES4 | 65.0 | 51.0 | 22.0 | 65.0 | 44.8 | 55.7 | 84.2 |
| ES5 | 60.0 | 48.0 | 20.0 | 60.0 | 46.9 | 51.3 | 88.5 |
| HL | 86.0 | 66.0 | 32.4 | 86.0 | 38.9 | 72.4 | 80.3 |

Two-Speed Fan Operation

The W7220 controller has the capability to work with a system using a 2-speed supply fan. The W7220 does not control the supply directly but uses the following input status to determine the speed of the supply fan and controls the OA damper to the required position.

| State | Fan Speed |
|-------|-----------|
| OCC | Low |
| Y1 | Low |
| Y2 | High |
| W | High |

The W (heating mode) is not controlled by the W7220 but it requires the status to know where to position the OA damper for minimum position for the fan speed.

The 2 speed fan delay is available when the system is programmed for 2 speed fan (in the System Setup menu item). The 2 speed fan delay is defaulted to 5 minutes and can be changed in the Advanced Setup menu item. When the unit has a call for Y1 In and in the free cooling mode

and there is a call for Y2 In, the 2-speed fan delay starts and the OA damper will modulate 100% open, the supply fan should be set to high speed by the unit controller.

After the delay one of two actions will happen:

- The Y2 In call will be satisfied with the damper 100% open and fan on high speed and the call will turn off

OR

- If the call for additional cooling in the space has not been satisfied then the first stage of mechanical cooling will be enabled through Y1 Out or Y2 Out.

Checkout

Inspect all wiring connections at the economizer module's terminals, and verify compliance with the installation wiring diagrams.

For checkout, review the Status of each configured parameter and perform the Checkout tests.

NOTE: See "Interface Overview" on page 28 for information about menu navigation and use of the keypad.

⚠ WARNING

ELECTRICAL SHOCK HAZARD

Failure to follow this warning could cause personal injury, death or property damage.

Before performing service or maintenance operations on unit, always turn off main power switch to unit and install lock(s) and lockout tag(s). Unit may have more than one power switch. Ensure electrical service to rooftop unit agrees with voltage and amperage listed on the unit rating plate.

If any wiring changes are required, first be sure to remove power from the economizer module before starting work. Pay particular attention to verifying the power connection (24 Vac).

Power Up —

After the W7220 module is mounted and wired, apply power.

Initial Menu Display —

On initial start up, **Honeywell** displays on the first line and **Economizer W7220** on the second line. After a brief pause, the revision of the software appears on the first line and the second line will be blank.

Power Loss (Outage or Brownout) —

All setpoints and advanced settings are restored* after any power loss or interruption.

Status —

Use the Status menu (see Table 11) to check the parameter values for the various devices and sensors configured.

NOTE: See “Interface Overview” on page 28 for information about menu navigation and use of the keypad.

Checkout Tests —

Use the Checkout menu (on page 33) to test the damper operation and any configured outputs. Only items that are configured are shown in the Checkout menu.

NOTE: See “Interface Overview” on page 28 for information about menu navigation and use of the keypad.

To perform a Checkout test:

1. Scroll to the desired test in the Checkout menu using the the ▲ and ▼ buttons.
2. Press the ← button to select the item.
3. RUN? appears.
4. Press the ← button to start the test.
5. The unit pauses and then displays IN PROGRESS.
6. When the test is complete, DONE appears.
7. When all desired parameters have been tested, press the ⏴ (Menu up) button to end the test.

* All settings are stored in non-volatile flash memory.

The Checkout tests can all be performed at the time of installation or at any time during the operation of the system as a test that the system is operable.

⚠ CAUTION

EQUIPMENT DAMAGE HAZARD

Failure to follow this caution may result in equipment damage.

Be sure to allow enough time for compressor startup and shutdown between checkout tests so that you do not short-cycle the compressors.

Troubleshooting

Alarms —

The Economizer module provides alarm messages that display on the 2-line LCD.

NOTE: Upon power up, the module waits 60 minutes before checking for alarms. This allows time for all the configured devices (e.g. sensors, actuator) to become operational. The exception is the SAT sensor which will alarm immediately.

If one or more alarms are present and there has been no keypad activity for at least 5 minutes, the Alarms menu displays and cycles through the active alarms.

You can also navigate to the Alarms menu at any time.

Clearing Alarms —

Once the alarm has been identified and the cause has been removed (e.g. replaced faulty sensor), the alarm can be cleared from the display.

To clear an alarm, perform the following:

1. Navigate to the desired alarm.
2. Press the ← button.
3. ERASE? displays.
4. Press the ← button.
5. ALARM ERASED displays.
6. Press the ⏴ (Menu up/Exit) button to complete the action and return to the previous menu.

NOTE: If the alarm still exists after you clear it, it is redisplayed within 5 seconds.

Staged Air Volume (SAV™) with Variable Frequency Drive (Factory-Installed Option)

For details on operating 50HCQ 2-stage cooling units equipped with the factory-installed Staged Air Volume option, refer to the Variable Frequency Drive (VFD) Installation, Start-Up and Service Instructions.

PremierLink™ Controller (Factory-Installed Option)

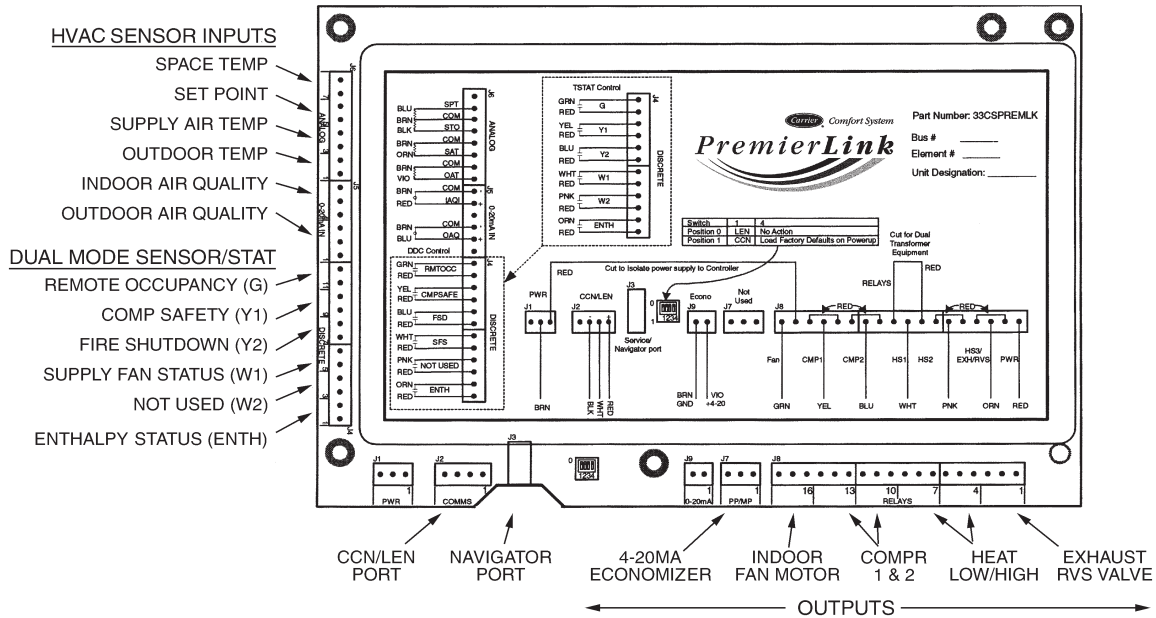

Fig. 48 - PremierLink Controller

C08199

The PremierLink controller (see Fig. 48) is compatible with Carrier Comfort Network® (CCN) devices. This control is designed to allow users the access and ability to change factory-defined settings, thus expanding the function of the standard unit control board. CCN service access tools include System Pilot™, Touch Pilot™ and Service Tool. (Standard tier display tools Navigator™ and Scrolling Marquee are not suitable for use with latest PremierLink controller (Version 2.x).)

The PremierLink control is factory-mounted in the 50HCQ unit's main control box to the left of the Central Terminal Board (CTB). Factory wiring is completed through harnesses connected to the CTB thermostat. Field connections are made at a 16-pole terminal block (TB3) located on the bottom shelf of the unit control box in front of the PremierLink controller. The factory-installed PremierLink control includes the supply-air temperature (SAT) sensor. The outdoor air temperature (OAT) sensor is included in the FIOP/accessory EconoMi\$er® 2 package.

The PremierLink controller requires the use of a Carrier electronic thermostat or a CCN connection for time broadcast to initiate its internal timeclock. This is necessary for broadcast of time of day functions (occupied/unoccupied).

NOTE: PremierLink controller is shipped in Sensor mode. To be used with a thermostat, the PremierLink controller must be configured to Thermostat mode. Refer to PremierLink Configuration instructions for Operating Mode.

Supply Air Temperature (SAT) Sensor —

On FIOP-equipped 50HCQ unit, the unit is supplied with a supply-air temperature (SAT) sensor (33ZCSENSAT). This sensor is a tubular probe type, approx 6-in. (12.7 mm) in length. It is a nominal 10-k ohm thermistor.

The SAT is factory-wired. The SAT probe is wire-tied to the supply-air opening (on the horizontal opening end) in its shipping position. Remove the sensor for installation. Re-position the sensor in the flange of the supply-air opening or in the supply air duct (as required by local codes). Drill or punch a 1/2-in. hole in the flange or duct. Use the template provided in the unit control box. Use two field-supplied, self-drilling screws to secure the sensor probe in a horizontal orientation. See Fig. 49.

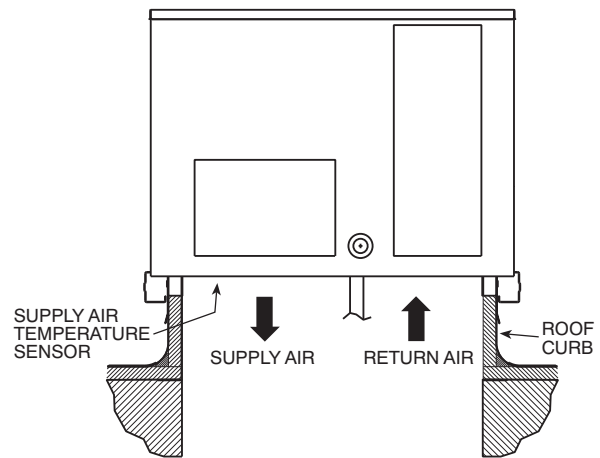

Fig. 49 - Typical Mounting Location for Supply Air Temperature (SAT) Sensor on Small Rooftop Units

C10020

NOTE: Refer to the PremierLink Controller Installation, Start-up, and Configuration Instructions for complete PremierLink controller configuration, operating sequences and troubleshooting information. Have a copy of this manual available at unit start-up.

NOTE: The sensor must be mounted in the discharge airstream downstream of the cooling coil and any heating devices. Be sure the probe tip does not come in contact with any of the unit's heater surfaces.

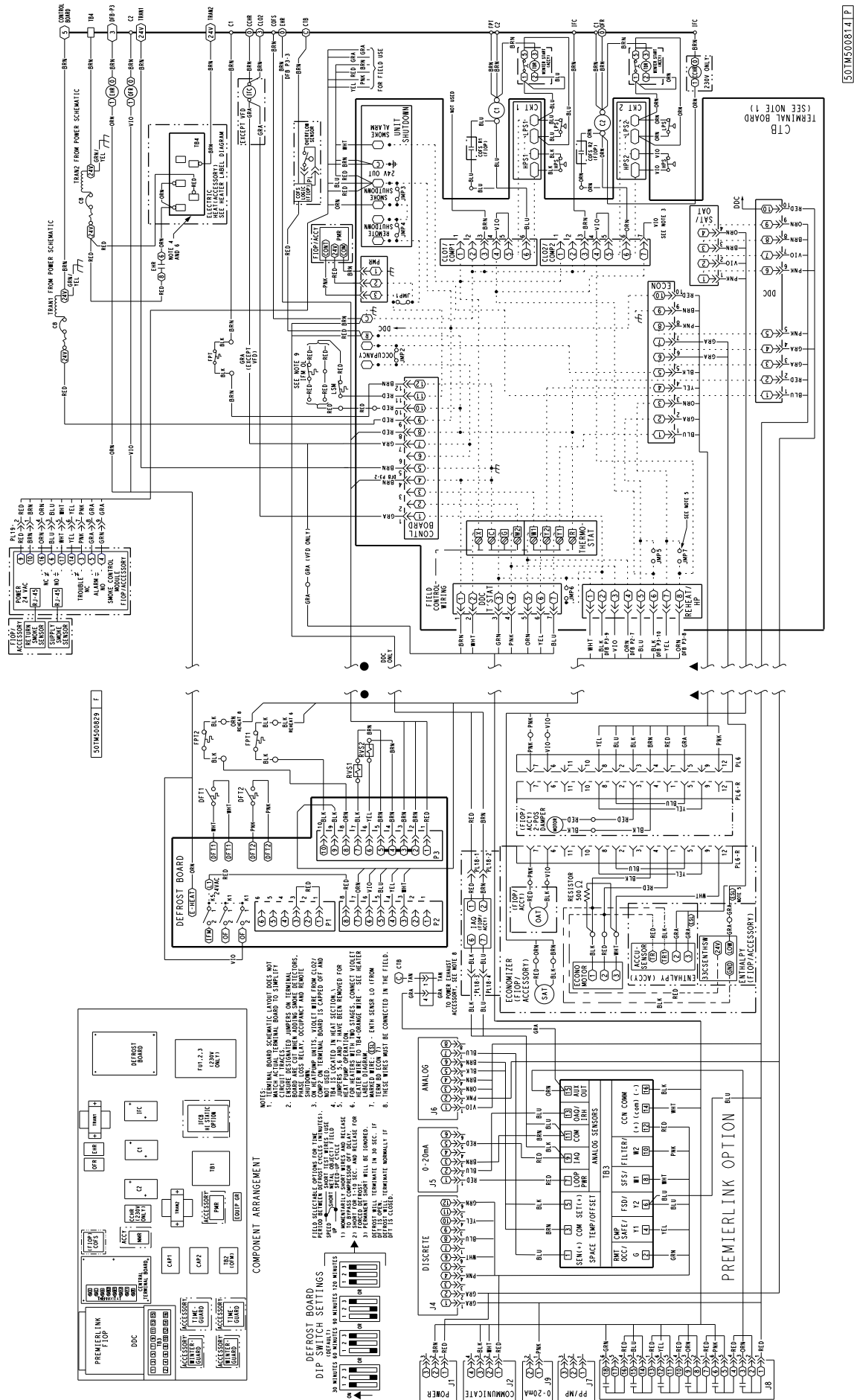

Fig. 50 - PremierLink™ Controller Wiring Schematic

Outdoor Air Temperature (OAT) Sensor —

The OAT is factory-mounted in the EconoMiSer® 2 (FIOP or accessory). It is a nominal 10k ohm thermistor attached to an eyelet mounting ring.

EconoMiSer 2 —

The PremierLink™ controller is used with EconoMiSer 2 (option or accessory) for outdoor air management. The damper position is controlled directly by the PremierLink controller; the EconoMiSer 2 unit has no internal logic device.

Outdoor air management functions can be enhanced with field-installation of these accessory control devices:

- Enthalpy control (outdoor air or differential sensors)
- Space CO₂ sensor
- Outdoor air CO₂ sensor

Refer to Table 22 on page 43 for accessory part numbers.

Field Connections

Field connections for accessory sensor and input devices are made at the 16-pole terminal block (TB3) located beneath the PremierLink control (see Fig. 50). Some input devices also require a 24-vac signal source; connect at CTB terminal R at “THERMOSTAT” connection strip for this signal source. See connections figures on following pages for field connection locations (and for continued connections at the PremierLink board inputs). Route wires to control box as indicated in Fig. 38 (on page 23).

Table 23 provides a summary of field connections for units equipped with Space Sensor. Table 24 provides a summary of field connections for units equipped with Space Thermostat.

Space Sensors —

The PremierLink controller is factory-shipped configured for Space Sensor Mode. A Carrier T-55 or T-56 space sensor must be used. T-55 space temperature sensor provides a signal of space temperature to the PremierLink control. T-56 provides same space temperature signal plus it allows for adjustment of space temperature setpoints from the face of the sensor.

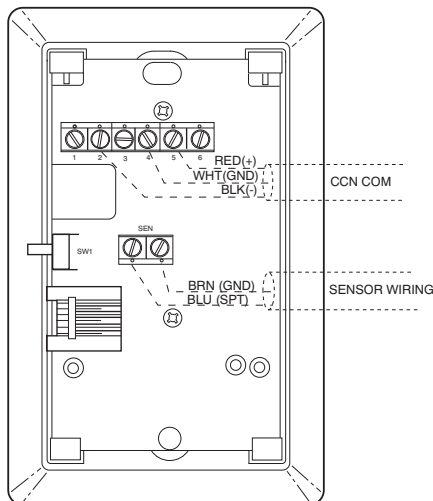

Fig. 51 - T-55 Space Temperature Sensor Wiring

C08201

Connect T-55: See Fig. 51 for typical T-55 internal connections. Connect the T-55 SEN terminals to TB3 terminals 1 and 3 (see Fig. 52).

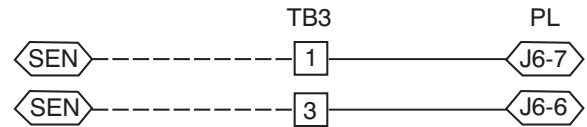

Fig. 52 - PremierLink Controller T-55 Sensor

C10023

Connect T-56: See Fig. 53 for T-56 internal connections. Install a jumper between SEN and SET terminals as illustrated. Connect T-56 terminals to TB3 terminals 1, 3 and 5 (see Fig. 54).

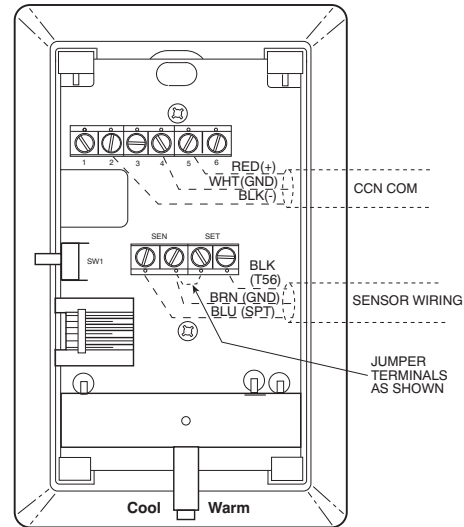

Fig. 53 - T-56 Internal Connections

C08202

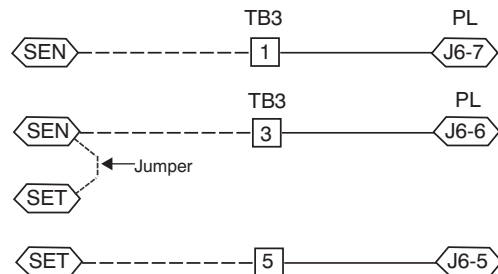

Fig. 54 - PremierLink T-56 Sensor

C10022

Connect Thermostat —

A 7-wire thermostat connection requires a 24-v power source and a common connection. Use the R and C terminals on the CTB's THERMOSTAT connection strip for these. Connect the thermostat's Y1, Y2, W1, W2 and G terminals to the PremierLink controller at TB3 as shown in Fig. 55.

If the 50HCQ unit is equipped with factory-installed smoke detector(s), disconnect the factory BLU lead at TB1-6 (Y2) before connecting the thermostat. Identify the BLU lead originating at CTB-DDC-1; disconnect at TB1-6 and tape off. Confirm that the second BLU lead at TB1-6 remains connected to the PremierLink controller at J4-8.

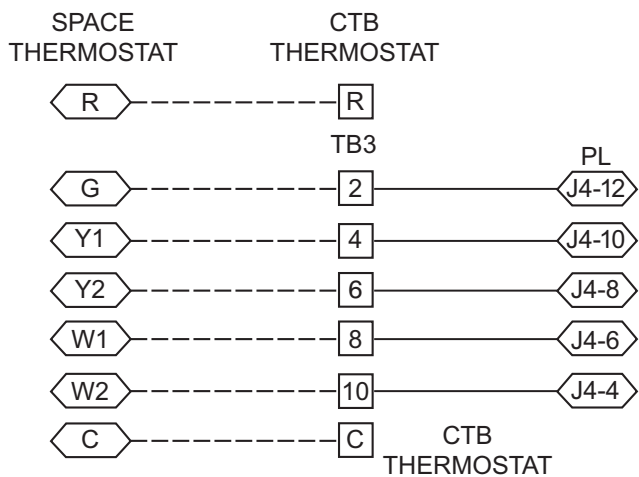

Fig. 55 - Space Thermostat Connections

C10283

If the 50HCQ unit has an economizer system and free-cooling operation is required, a sensor representing Return Air Temperature must also be connected (field-supplied and installed). This sensor may be a T-55 Space Sensor (see Fig. 51 on page 42) installed in the space or in the return duct, or it may be sensor P/N 33ZCESENSAT, installed in the return duct. Connect this sensor to TB3-1 and TB3-3 per Fig. 52 (on page 42).

Configure the unit for Thermostat Mode —

Connect to the CCN bus using a CCN service tool and navigate to PremierLink Configuration screen for Operating Mode. Default setting is Sensor Mode (value 1). Change the value to 0 to reconfigure the controller for Thermostat Mode.

When the PremierLink is configured for Thermostat Mode, these functions are not available: Fire Shutdown (FSD), Remote Occupied (RMT OCC), Compressor Safety (CMPSAFE), Supply Fan Status (SFS), and Filter Pressure Switch (FILTER).

Table 22 – PremierLink Sensor Usage

| APPLICATION | OUTDOOR AIR TEMPERATURE SENSOR | RETURN AIR TEMPERATURE SENSOR | OUTDOOR AIR ENTHALPY SENSOR | RETURN AIR ENTHALPY SENSOR |
|--|--------------------------------|-------------------------------------|-------------------------------------|-------------------------------------|
| Differential Dry Bulb Temperature with PremierLink (PremierLink requires 4–20 mA Actuator) | Included – CRTEMPN001A00 | Required – 33ZCT55SPT or equivalent | – | – |
| Single Enthalpy with PremierLink (PremierLink requires 4–20mA Actuator) | Included – Not Used | – | Requires – 33CSENTHSW | – |
| Differential Enthalpy with PremierLink (PremierLink requires 4–20mA Actuator) | Included – Not Used | – | Requires – 33CSENTHSW or equivalent | Requires – 33CSENTSEN or equivalent |

NOTES:

CO₂ Sensors (Optional):

33ZCSENCO2 – Room sensor (adjustable). Aspirator box is required for duct mounting of the sensor.

33ZCASPCO2 – Aspirator box used for duct-mounted CO₂ room sensor.

33ZCT55CO2 – Space temperature and CO₂ room sensor with override.

33ZCT56CO2 – Space temperature and CO₂ room sensor with override and setpoint.

Table 23 – Space Sensor Mode

| TB1 TERMINAL | FIELD CONNECTION | INPUT SIGNAL |
|--------------|------------------------------|-------------------------|
| 1 | T55 – SEN/T56 – SEN | Analog (10k thermistor) |
| 2 | RMTOCC | Discrete, 24VAC |
| 3 | T55 – SEN/T56 – SEN | Analog (10k thermistor) |
| 4 | CMPSAFE | Discrete, 24VAC |
| 5 | T56 – SET | Analog (10k thermistor) |
| 6 | FSD | Discrete, 24VAC |
| 7 | LOOP – PWR | Analog, 24VDC |
| 8 | SFS | Discrete, 24VAC |
| 9 | IAQ – SEN | Analog, 4 – 20mA |
| 10 | FILTER | Discrete, 24VAC |
| 11 | IAQ – COM/OAQ – COM/RH – COM | Analog, 4 – 20mA |
| 12 | CCN + (RED) | Digital, , 5VDC |
| 13 | OAQ – SEN/RH – SEN | Analog, 4 – 20mA |
| 14 | CCN Gnd (WHT) | Digital, 5VDC |
| 15 | AUX OUT (Power Exhaust) | (Output) Discrete 24VAC |
| 16 | CCN – (BLK) | Digital, 5VDC |

LEGEND:

- | | | | |
|---------|--|-----|--|
| T55 | – Space Temperature Sensor | FSD | – Fire Shutdown |
| T56 | – Space Temperature Sensor | IAQ | – Indoor Air Quality (CO ₂) |
| CCN | – Carrier Comfort Network [®] (communication bus) | OAQ | – Outdoor Air Quality (CO ₂) |
| CMPSAFE | – Compressor Safety | RH | – Relative Humidity |
| FILTER | – Dirty Filter Switch | SFS | – Supply Fan Status |

Table 24 – Thermostat Mode

| TB3 TERMINAL | FIELD CONNECTION | INPUT SIGNAL |
|--------------|------------------------------|-------------------------|
| 1 | RAT SEN | Analog (10k thermistor) |
| 2 | G | Discrete, 24VAC |
| 3 | RAT SEN | Analog (10k thermistor) |
| 4 | Y1 | Discrete, 24VAC |
| 5 | — | — |
| 6 | Y2 | Discrete, 24VAC |
| 7 | LOOP – PWR | Analog, 24VDC |
| 8 | W1 | Discrete, 24VAC |
| 9 | IAQ – SEN | Analog, 4 – 20mA |
| 10 | W2 | Discrete, 24VAC |
| 11 | IAQ – COM/OAQ – COM/RH – COM | Analog, 4 – 20mA |
| 12 | CCN + (RED) | Digital, 5VDC |
| 13 | OAQ – SEN/RH – SEN | Analog, 4 – 20mA |
| 14 | CCN Gnd (WHT) | Digital, 5VDC |
| 15 | AUX OUT (Power Exhaust) | (Output) Discrete 24VAC |
| 16 | CCN – (BLK) | Digital, 5VDC |

LEGEND:

- | | | | |
|-----|--|----|---------------------------|
| CCN | – Carrier Comfort Network [®] (communication bus) | RH | – Relative Humidity |
| G | – Thermostat Fan | W1 | – Thermostat Heat Stage 1 |
| IAQ | – Indoor Air Quality (CO ₂) | W2 | – Thermostat Heat Stage 2 |
| OAQ | – Outdoor Air Quality (CO ₂) | Y1 | – Thermostat Cool Stage 1 |
| RAT | – Return Air Temperature | Y2 | – Thermostat Cool Stage 2 |

Economizer Controls

Indoor Air Quality (CO₂ Sensor) —

The indoor air quality sensor accessory monitors space carbon dioxide (CO₂) levels. This information is used to monitor IAQ levels. Several types of sensors are available, for wall mounting in the space or in return duct, with and without LCD display, and in combination with space temperature sensors. Sensors use infrared technology to measure the levels of CO₂ present in the space air.

The CO₂ sensors are all factory set for a range of 0 to 2000 ppm and a linear mA output of 4 to 20. Refer to the instructions supplied with the CO₂ sensor for electrical requirements and terminal locations. See Fig. 56 for typical CO₂ sensor wiring schematic.

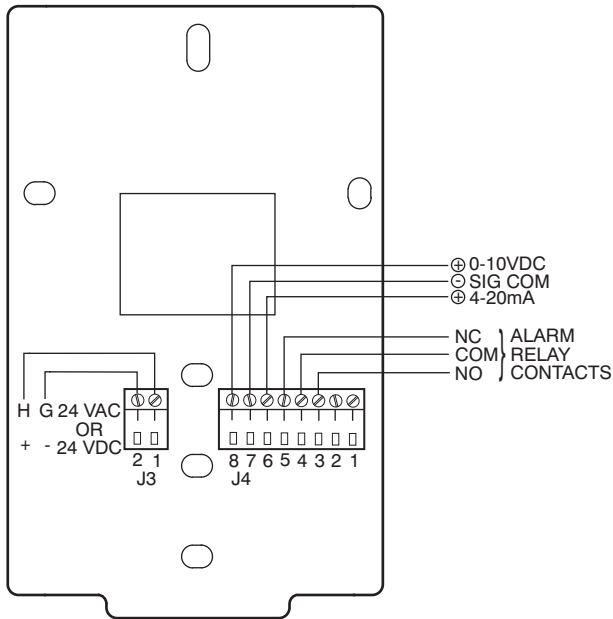

C08635

Fig. 56 - Indoor/Outdoor Air Quality (CO₂) Sensor (33ZCSENC02) - Typical Wiring Diagram

To accurately monitor the quality of the air in the conditioned air space, locate the sensor near a return-air grille (if present) so it senses the concentration of CO₂ leaving the space. The sensor should be mounted in a location to avoid direct breath contact.

Do not mount the IAQ sensor in drafty areas such as near supply ducts, open windows, fans, or over heat sources. Allow at least 3 ft (0.9 m) between the sensor and any corner. Avoid mounting the sensor where it is influenced by the supply air; the sensor gives inaccurate readings if the supply air is blown directly onto the sensor or if the supply air does not have a chance to mix with the room air before it is drawn into the return airstream.

Wiring the Indoor Air Quality Sensor: For each sensor, use two 2-conductor 18 AWG (American Wire Gauge) twisted-pair cables (unshielded) to connect the separate isolated 24 vac power source to the sensor and to connect the sensor to the control board terminals.

To connect the sensor to the control, identify the positive (4 to 20 mA) and ground (SIG COM) terminals on the

sensor. See Fig. 41. Connect the 4-20 mA terminal to terminal TB3-9 and connect the SIG COM terminal to terminal TB3-11. See Fig. 57.

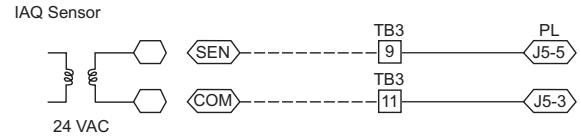

C10284

Fig. 57 - Indoor CO₂ Sensor (33ZCSENC02) Connections

Refer to the PremierLink™ Installation, Start-up, and Configuration Instructions, for detailed configuration information.

Outdoor Air Quality Sensor (P/N 33ZCSENC02 plus weatherproof enclosure) —

The outdoor air CO₂ sensor is designed to monitor carbon dioxide (CO₂) levels in the outside ventilation air and interface with the ventilation damper in an HVAC system. The OAQ sensor is packaged with an outdoor cover. See Fig. 58. The outdoor air CO₂ sensor must be located in the economizer outside air hood.

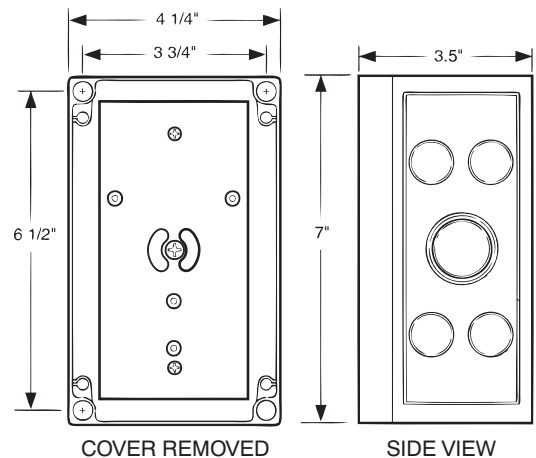

C07135

Fig. 58 - Outdoor Air Quality Sensor Cover

Wiring the Outdoor Air CO₂ Sensor: A dedicated power supply is required for this sensor. A two-wire cable is required to wire the dedicated power supply for the sensor. The two wires should be connected to the power supply and terminals 1 and 2.

To connect the sensor to the control, identify the positive (4 to 20 mA) and ground (SIG COM) terminals on the OAQ sensor. See Fig. 56. Connect the 4 to 20 mA terminal to the TB3-13 terminal of the 50HCQ unit. Connect the SIG COM terminal to the TB3-11 terminal of the 50HCQD unit. See Fig. 59.

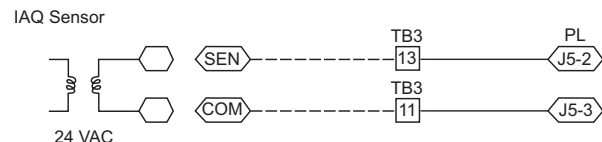

C10285

Fig. 59 - Outdoor CO₂ Sensor Connections

Smoke Detector/Fire Shutdown (FSD) —

This function is available only when the PremierLink™ controller is configured for (Space) Sensor Mode. The unit is factory-wired for PremierLink FSD operation when the PremierLink controller is factory-installed.

On 50HCQ units equipped with factory-installed Smoke Detector(s), the smoke detector controller implements the unit shutdown through its NC contact set connected to the unit's CTB input. The FSD function is initiated via the smoke detector's Alarm NO contact set. The PremierLink controller communicates the smoke detector's tripped status to the CCN building control. See Fig. 50, the PremierLink controller wiring schematic.

Filter Status Switch —

This function is available only when PremierLink is configured for (Space) Sensor Mode.

PremierLink controller can monitor return filter status in two ways: By monitoring a field-supplied/installed filter pressure switch or via supply fan runtime hours.

Using switch input: Install the dirty filter pressure switch according to switch manufacturer's instructions, to measure pressure drop across the unit's return filters. Connect one side of the switch's NO contact set to CTB's THERMOSTAT-R terminal. Connect the other side of the NO contact set to TB3-10. Setpoint for Dirty Filter is set at the switch. See Fig. 60.

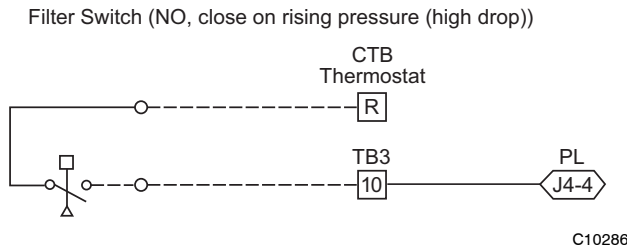

Fig. 60 - PremierLink Controller Filter Switch Connection

When the filter switch's NO contact set closes as filter pressure drop increases (indicating dirt-laden filters), the input signal to the PremierLink controller causes the filter status point to read "DIRTY".

Using Filter Timer Hours: Refer to the PremierLink Controller Installation, Start-up, and Configuration Instructions for instructions on using the PremierLink configuration screens and on unit alarm sequence.

Supply Fan Status Switch —

The PremierLink controller can monitor supply fan operation through a field-supplied/installed differential pressure switch. This sequence will prevent (or interrupt) operation of unit cooling, heating and economizer functions until the pressure switch contacts are closed indicating proper supply fan operation.

Install the differential pressure switch in the supply fan section according to switch manufacturer's instructions.

Arrange the switch contact to be open on no flow and to close as pressure rises indicating fan operation.

Connect one side of the switch's NO contact set to CTB's THERMOSTAT-R terminal. Connect the other side of the NO contact set to TB3-8. Setpoint for Supply Fan Status is set at the switch. See Fig. 61.

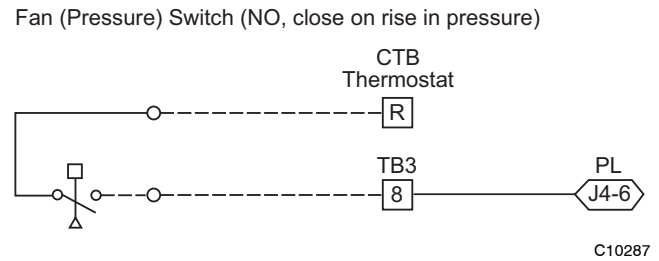

Fig. 61 - PremierLink Wiring Fan Pressure Switch Connection

Remote Occupied Switch —

The PremierLink controller permits a remote timeclock to override the control's on-board occupancy schedule and place the unit into Occupied mode. This function may also provide a "Door Switch" time delay function that will terminate cooling and heating functions after a 2 to 20 minute delay.

Connect one side of the NO contact set on the timeclock to CTB's THERMOSTAT-R terminal. Connect the other side of the timeclock contact to the unit's TB3-2 terminal.

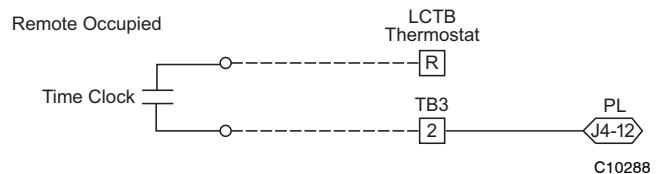

Fig. 62 - PremierLink Controller Wiring Remote Occupied

Refer to the PremierLink Controller Installation, Start-up, and Configuration Instructions for additional information on configuring the PremierLink controller for Door Switch timer function.

Space Relative Humidity Sensor —

The RH sensor is not used with 50HCQ models at this time.

Power Exhaust (output) —

Connect the accessory Power Exhaust contactor coil(s) per Fig. 48.

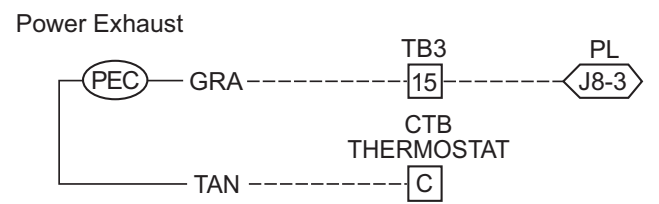

Fig. 63 - PremierLink Controller Power Exhaust Output Connection

CCN Communication Bus —

The PremierLink™ controller connects to the bus in a daisy chain arrangement. Negative pins on each component must be connected to respective negative pins, and likewise, positive pins on each component must be connected to respective positive pins. The controller signal pins must be wired to the signal ground pins. Wiring connections for CCN must be made at the 3-pin plug.

At any baud (9600, 19200, 38400 baud), the number of controllers is limited to 239 devices maximum. Bus length may not exceed 4000 ft, with no more than 60 total devices on any 1000-ft section. Optically isolated RS-485 repeaters are required every 1000 ft.

NOTE: Carrier device default is 9600 band.

Communications Bus Wire Specifications - The CCN Communication Bus wiring is field-supplied and field-installed. It consists of shielded 3-conductor cable with drain (ground) wire. The cable selected must be identical to the CCN Communication Bus wire used for the entire network.

See Table 25 for recommended cable.

Table 25 – Recommended Cables

| MANUFACTURER | CABLE PART NO. |
|--------------|----------------|
| Alpha | 2413 or 5463 |
| American | A22503 |
| Belden | 8772 |
| Columbia | 02525 |

NOTE: Conductors and drain wire must be at least 20 AWG, stranded, and tinned copper. Individual conductors must be insulated with PVC, PVC/nylon, vinyl, Teflon*, or polyethylene. An aluminum/polyester 100% foil shield and an outer jacket of PVC, PVC/nylon, chrome vinyl, or Teflon with a minimum operating temperature range of -20°C to 60°C is required. Do not run communication wire in the same conduit as or next to any AC voltage wiring.

* Teflon is a registered trademark of DuPont.

The communication bus shields must be tied together at each system element. If the communication bus is entirely within one building, the resulting continuous shield must be connected to ground at only one single point. If the communication bus cable exits from one building and enters another building, the shields must be connected to the grounds at a lightning suppressor in each building (one point only).

Connecting CCN Bus:

NOTE: When connecting the communication bus cable, a color code system for the entire network is recommended to simplify installation and checkout. See Table 6 for the recommended color code.

Table 26 – Color Code Recommendations

| SIGNAL TYPE | CCN BUS WIRE COLOR | CCN PLUG PIN NUMBER |
|-------------|--------------------|---------------------|
| + | Red | 1 |
| Ground | White | 2 |
| - | Black | 3 |

Connect the CCN (+) lead (typically RED) to the unit's TB3-12 terminal. Connect the CCN (ground) lead (typically WHT) to the unit's TB3-14 terminal. Connect the CCN (-) lead (typically BLK) to the unit's TB3-16 terminal. See Fig. 64.

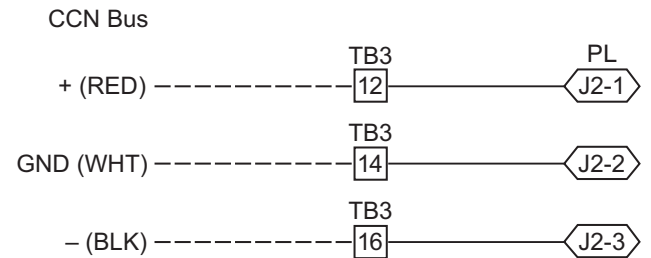

C10290

Fig. 64 - PremierLink Controller CCN Bus Connections

Table 27 – RTU Open Controller Inputs and Outputs

| POINT NAME | BACnet OBJECT NAME | TYPE OF I/O | CONNECTION PIN NUMBER(S) | CHANNEL DESIGNATION |
|---|---------------------|-------------------------|---|--|
| DEDICATED INPUTS | | | | |
| Space Temp / Zone Temp | zone_temp | AI (10K Thermistor) | J20–1 and 2 | Analog Input 10 |
| Supply Air Temperature | sa_temp | AI (10K Thermistor) | J2–1 and 2 | Analog Input 6 |
| Outside Air Temperature | oa_temp | AI (10K Thermistor) | J2–3 and 4 | Analog Input 7 |
| Space Temperature Offset Pot | stpt_adj_offset | AI (100K Potentiometer) | J20–3 and 4 | Analog Input 11 |
| Safety Chain Feedback | safety_status | BI (24 VAC) | J1–9 | Binary Input 4 |
| Compressor Safety Status ⁽¹⁾ | comp_status | BI (24 VAC) | J1–2 | Binary Input 3 |
| Fire Shutdown Status | firedown_status | BI (24 VAC) | J1–10 | Binary Input 5 |
| Enthalpy Status | enthalpy_status | BI (24 VAC) | J2–6 and 7 | Binary Input 8 |
| Humidistat Input Status | humstat_status | BI (24 VAC) | J5–7 and 8 | Binary Input 9 |
| Zone Temperature | n/a | n/a | J13–1–4 | Rnet |
| CONFIGURABLE INPUTS ⁽⁴⁾ | | | | |
| Indoor Air CO2 | iaq | AI (4–20 mA) | J4–2 and 3 or J4–5 and 6 | Analog Input 2 |
| Outdoor Air CO2 | oaq | AI (4–20 mA) | | Analog Input 1 |
| Space Relative Humidity | space_rh | AI (4–20 mA) | | Analog Input 10 |
| Supply Fan Status ⁽²⁾ | sfan_status | BI (24 VAC) | J5–1 and 2 or J5–3 and 4, J5–5 and 6 or J5–7 and 8 ⁽³⁾ | Binary Input 3, 5, 8, or 9, except where intrinsic input is used |
| Filter Status ⁽²⁾ | filter_status | BI (24 VAC) | | Binary Input 3, 5, 8, or 9, except where intrinsic input is used |
| Door Contact ⁽²⁾ | door_contact_status | BI (24 VAC) | | Binary Input 3, 5, 8, or 9, except where intrinsic input is used |
| Remote Occupancy input ⁽²⁾ | occ_contact_status | BI (24 VAC) | | Binary Input 3, 5, 8, or 9, except where intrinsic input is used |
| IGC input ⁽²⁾ | igcovr_status | BI (24 VAC) | | Binary Input 9. Mandatory input on gas heat units |
| OUTPUTS | | | | |
| Economizer Output | econ_output | AO (4–20mA) | J2–5 | Analog Output 1 |
| Supply Fan VFD | vfd_output | AO (2–10Vdc) | J22–1 and 2 | Analog Output 2 |
| Supply Fan Relay | sfan | BO Relay (24VAC, 1A) | J1–4 | Binary Output 1 (G) |
| Cool 1 Relay State | comp_1 | BO Relay (24VAC, 1A) | J1–8 | Binary Output 5 (Y1) |
| Cool 2 Relay State | comp_2 | BO Relay (24VAC, 1A) | J1–7 | Binary Output 4 (Y2) |
| Cool 3 Relay State | comp_3 | BO Relay (24VAC, 1A) | J11–5 and 6 | Binary Output 7 (Y3) |
| Heat 1 Relay State | heat_1 | BO Relay (24VAC, 1A) | J1–6 | Binary Output 3 (W1) |
| Heat 2 Relay State | heat_2 | BO Relay (24VAC, 1A) | J1–5 | Binary Output 2 (W2) |
| Power Exhaust Relay State | pexh | BO Relay (24VAC, 1A) | J11–2 and 3 (N.O.) | Binary Output 8 (PE) |
| Dehumidification Relay | dehum | BO Relay (24VAC, 1A) | J11–7 and 8 (N.O.) | Binary Output 6 |

LEGEND

- AI – Analog Input
- AO – Analog Output
- BI – Binary Input
- BO – Binary Output

⁽¹⁾ Safety Chain Feedback: 24 vac required at this terminal to provide "Run Enable" status. See Input/Output section for additional instructions.

⁽²⁾ These inputs are configurable. If installed, they take the place of the default input on the specific channel. See appropriate Input Configuration Section for wiring and setup instructions.

⁽³⁾ Parallel pins J5–1 = J2–6, J5–3 = J1–10, J5–5 = J1–2 are used for field–installation.

⁽⁴⁾ Refer to the input configuration and accessory sections of the RTU Open Multi–Protocol Controller Controls, Start–Up, Operation and Troubleshooting manual for more detail.

The RTU Open controller requires the use of a Carrier space sensor. A standard thermostat cannot be used with the RTU Open controller system.

Supply Air Temperature (SAT) Sensor —

On FIOP-equipped 50HCQ unit, the unit is supplied with a supply-air temperature (SAT) sensor (33ZCSENSAT). This sensor is a tubular probe type, approx 6-in. (152 mm) in length. It is a nominal 10-k ohm thermistor.

The SAT is factory-wired. The SAT probe is wire-tied to the supply-air opening (on the horizontal opening end) in its shipping position. Remove the sensor for installation. Re-position the sensor in the flange of the supply-air opening or in the supply air duct (as required by local codes). Drill or punch a 1/2-in. hole in the flange or duct. Use two field-supplied, self-drilling screws to secure the sensor probe in a horizontal orientation. See Fig. 49.

Outdoor Air Temperature (OAT) Sensor —

The OAT is factory-mounted in the EconoMiSer[®] 2 (FIOP or accessory). It is a nominal 10k ohm thermistor attached to an eyelet mounting ring.

EconoMiSer 2 —

The RTU Open controller is used with EconoMiSer 2 (option or accessory) for outdoor air management. The damper position is controlled directly by the RTU Open controller; the EconoMiSer 2 unit has no internal logic device.

Outdoor air management functions can be enhanced with field-installation of these accessory control devices:

- Enthalpy control (outdoor air or differential sensors)
- Space CO₂ sensor
- Outdoor air CO₂ sensor

Field Connections

Field connections for accessory sensors and input devices are made the RTU Open controller, at plugs J1, J2, J4, J5, J11 and J20. All field control wiring that connects to the RTU Open controller must be routed as shown in Fig. 38. This routing provides the UL required clearance between high and low-voltage wiring. Connect to the wires to the removable PCB connectors and then reconnect the connectors to the board.

Space Temperature (SPT) Sensors —

There are two types of SPT sensors available from Carrier, resistive input non-communicating (T55, T56, and T59) and Rnet communicating (SPS, SPPL, SPP, and SPPF) sensors. Each type has a variety of options consisting of: timed override button, set point adjustment, a LCD screen, and communication tie in. Space temperature can be also be written to from a building network or zoning system. However, it is still recommended that return air duct sensor be installed to allow stand-alone operation for back-up. Refer to the configuration section for details on controller configurations associated with space sensors.

- 33ZCT55SPT, space temperature sensor with override button (T-55)
- 33ZCT56SPT, space temperature sensor with override button and setpoint adjustment (T-56)
- 33ZCT59SPT, space temperature sensor with LCD (liquid crystal display) screen, override button, and setpoint adjustment (T-59)

Use 20 gauge wire to connect the sensor to the controller. The wire is suitable for distances of up to 500 ft. Use a three-conductor shielded cable for the sensor and setpoint adjustment connections. If the setpoint adjustment (slidebar) is not required, then an unshielded, 18 or 20 gauge, two-conductor, twisted pair cable may be used.

Connect T-55: See Fig. 51 for typical T-55 internal connections. Connect the T-55 SEN terminals to the RTU Open controller at J20-1 and J20-2. See Fig. 67.

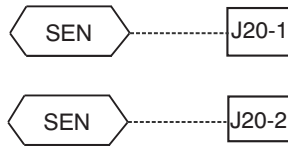

Fig. 67 - RTU Open Controller T-55 Sensor Connections

C08460

Connect T-56: See Fig. 53 for T-56 internal connections. Install a jumper between SEN and SET terminals as illustrated. Connect T-56 terminals to the RTU Open controller J20-1, J20-2 and J20-3 per Fig. 68.

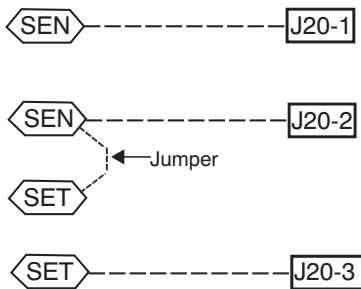
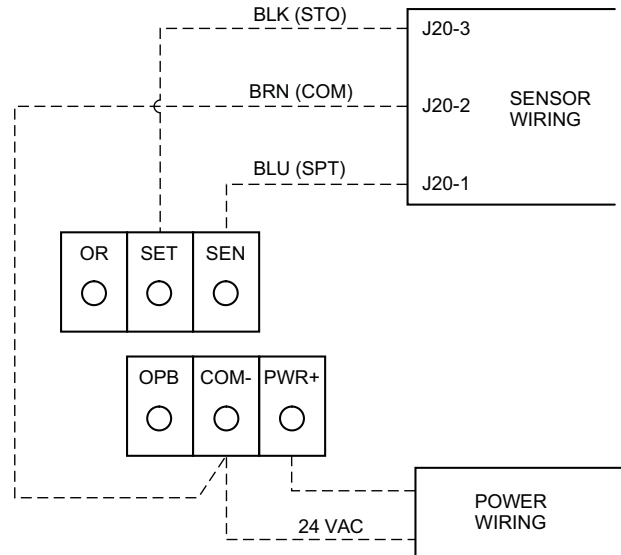

Fig. 68 - RTU Open Controller T-56 Sensor Connections

C08461

Connect T-59: The T-59 space sensor requires a separate, isolated power supply of 24 VAC. See Fig. 69

for internal connections at the T-59. Connect the SEN terminal (BLU) to the RTU Open controller at J20-1. Connect the COM terminal (BRN) to J20-2. Connect the SET terminal (STO or BLK) to J20-3.



NOTE: Must use a separate isolated transformer.

C10291

Fig. 69 - Space Temperature Sensor Typical Wiring (33ZCT59SPT)

Indoor Air Quality (CO₂) Sensor —

The indoor air quality sensor accessory monitors space carbon dioxide (CO₂) levels. This information is used to monitor IAQ levels. Several types of sensors are available, for wall mounting in the space or in return duct, with and without LCD display, and in combination with space temperature sensors. Sensors use infrared technology to measure the levels of CO₂ present in the space air.

The CO₂ sensors are all factory set for a range of 0 to 2000 ppm and a linear mA output of 4 to 20. Refer to the instructions supplied with the CO₂ sensor for electrical requirements and terminal locations. See Fig. 56 for typical CO₂ sensor wiring schematic.

To accurately monitor the quality of the air in the conditioned air space, locate the sensor near a return-air grille (if present) so it senses the concentration of CO₂ leaving the space. The sensor should be mounted in a location to avoid direct breath contact.

Do not mount the IAQ sensor in drafty areas such as near supply ducts, open windows, fans, or over heat sources. Allow at least 3 ft (0.9 m) between the sensor and any corner. Avoid mounting the sensor where it is influenced by the supply air; the sensor gives inaccurate readings if the supply air is blown directly onto the sensor or if the supply air does not have a chance to mix with the room air before it is drawn into the return airstream.

Wiring the Indoor Air Quality Sensor: For each sensor, use two 2-conductor 18 AWG (American Wire Gage) twisted-pair cables (unshielded) to connect the separate isolated 24 vac power source to the sensor and to connect the sensor to the RTU Open controller board terminals.

To connect the sensor to the control, identify the positive (4 to 20 mA) and ground (SIG COM) terminals on the sensor. See Fig. 56. Connect the 4-20 mA terminal to the RTU Open controller at J4-2 and connect the SIG COM terminal to the RTU Open controller at J4-3. See Fig. 70.

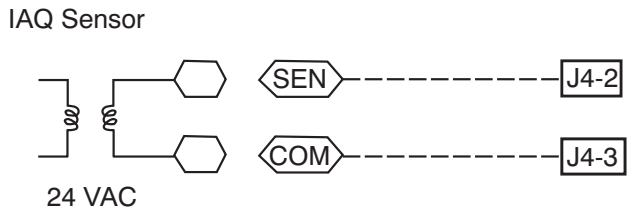

C08462

Fig. 70 - RTU Open Controller / Indoor CO₂ Sensor (33ZCSENCO2) Connections

Outdoor Air Quality Sensor (P/N 33ZCSENCO2 plus weatherproof enclosure) —

The outdoor air CO₂ sensor is designed to monitor carbon dioxide (CO₂) levels in the outside ventilation air and interface with the ventilation damper in an HVAC system. The OAQ sensor is packaged with an outdoor cover. See Fig. 58. The outdoor air CO₂ sensor must be located in the economizer outside air hood.

Wiring the Outdoor Air CO₂ Sensor: A dedicated power supply is required for this sensor. A two-wire cable is required to wire the dedicated power supply for the sensor. The two wires should be connected to the power supply and terminals 1 and 2.

To connect the sensor to the control, identify the positive (4 to 20 mA) and ground (SIG COM) terminals on the OAQ sensor. See Fig. 56. Connect the 4 to 20 mA terminal to the RTU Open controller at J4-5. Connect the SIG COM terminal to the RTU Open controller at J4-6.

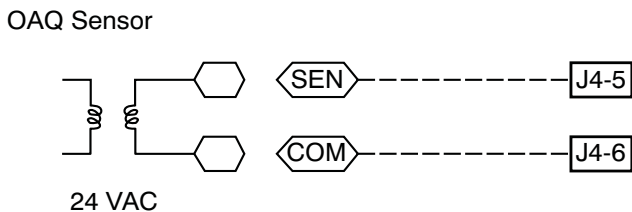

C11086

Fig. 71 - RTU Open Controller / Outdoor CO₂ Sensor (33ZCSENCO2) Connections

Space Relative Humidity Sensor—

The Space Relative Humidity Sensor is not used with 50HCQ units at this time.

Smoke Detector/Fire Shutdown (FSD) —

On 50HCQ units equipped with factory-installed Smoke Detector(s), the smoke detector controller implements the unit shutdown through its NC contact set connected to the unit's CTB input. The FSD function is initiated via the smoke detector's Alarm NO contact set. The RTU Open controller communicates the smoke detector's tripped status to the BAS building control. See Fig. 66 (RTU Open controller system wiring diagram).

The Fire Shutdown Switch configuration, *MENU* → *Config* → *Inputs* → *input 5*, identifies the normally open status of this input when there is no fire alarm.

Connecting Discrete Inputs —

Filter Status: The filter status accessory is a field-installed accessory. This accessory detects plugged filters. When installing this accessory, the unit must be configured for filter status by setting *MENU* → *Config* → *Inputs* → *input 3, 5, 8, or 9* to Filter Status and normally open (N/O) or normally closed (N/C). Input 8 or 9 is recommended for ease of installation. Refer to Fig. 65 and 66 for wire terminations at J5.

Fan Status: The fan status accessory is a field-installed accessory. This accessory detects when the indoor fan is blowing air. When installing this accessory, the unit must be configured for fan status by setting *MENU* → *Config* → *Inputs* → *input 3, 5, 8, or 9* to Fan Status and normally open (N/O) or normally closed (N/C). Input 8 or 9 is recommended for ease of installation. Refer to Fig. 65 and 66 for wire terminations at J5.

Remote Occupancy: The remote occupancy accessory is a field-installed accessory. This accessory overrides the unoccupied mode and puts the unit in occupied mode. When installing this accessory, the unit must be configured for remote occupancy by setting *MENU* → *Config* → *Inputs* → *input 3, 5, 8, or 9* to Remote Occupancy and normally open (N/O) or normally closed (N/C).

Also set *MENU* → *Schedules* → *occupancy source* to DI on/off. Input 8 or 9 is recommended for ease of installation. Refer to Fig. 65 and Table 27 for wire terminations at J5.

Power Exhaust (output): The relay used by the RTU Open controller board to control power exhaust is a dry contact which means it does not have 24 vac. This 24 vac must be connected to the relay to allow it to operate the power exhaust relay in the PE accessory. A 24 vac source must be provided to J11-2 on the RTU Open controller board. This can be provided by the unit's transformer from various sources. The "R" terminal on the unit's central terminal board (CTB) is a logical source. Refer to Fig. 65 and 66 for wire terminations at J11.

Communication Wiring - Protocols

General —

Protocols are the communication languages spoken by control devices. The main purpose of a protocol is to communicate information in the most efficient method possible. Different protocols exist to provide different kinds of information for different applications. In the BAS application, many different protocols are used, depending on manufacturer. Protocols do not change the function of a controller; just make the front end user different.

The RTU Open controller can be set to communicate on four different protocols: BACnet, Modbus, N2, and LonWorks. Switch 3 (SW3) on the board is used to set protocol and baud rate. Switches 1 and 2 (SW1 and SW2) are used to set the board's network address. See Fig. 72 and 73 for protocol switch settings. The third party connection to the RTU Open controller is through plug J19. See Fig. 74 for wiring.

NOTE: Power must be cycled after changing the SW1-3 switch settings.

Refer to the *RTU Open v3 Integration Guide* for more detailed information on protocols, third party wiring, and networking.

Local Access

Wall Mounted Equipment Touch™ Interface: The Equipment Touch interface is a wall mounted interface used to connect to the RTU Open controller to access the control information, read sensor values, and perform maintenance. This is an accessory interface that does not come with the RTU Open controller. Wire the Equipment Touch interface to the RTU Open controller J13 local access port. There are 2 password protected levels in the display (User and Admin). See the Equipment Touch Installation and Setup Guide for more information. See Appendix A in the guide for navigation and screen content.

SW3 Protocol Selection

| PROTOCOL | DS8 | DS7 | DS6 | DS5 | DS4 | DS3 | DS2 | DS1 |
|------------------------------|--------|-----|-----|-----|-----|-----|-------------|-------------|
| BACnet MS/TP (Master) | Unused | OFF | OFF | OFF | ON | OFF | Select Baud | Select Baud |
| Modbus (Slave) | Unused | OFF | OFF | ON | ON | OFF | Select Baud | Select Baud |
| N2 (Slave) | Unused | OFF | OFF | OFF | ON | ON | OFF | OFF |
| LonWorks | Unused | ON | ON | OFF | ON | OFF | OFF | ON |

NOTE:

DS = DIP Switch

BACnet MS/TP SW3 example shown

Baud Rate Selections

| BAUD RATE | DS2 | DS1 |
|-----------|-----|-----|
| 9600 | OFF | OFF |
| 19,200 | ON | OFF |
| 38,400 | OFF | ON |
| 76,800 | ON | ON |

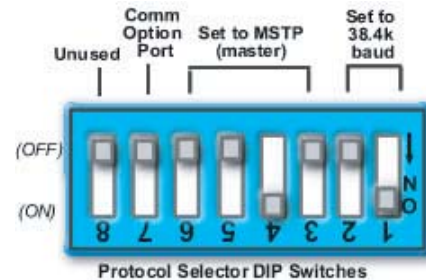

C07166

Fig. 72 - RTU Open Controller SW3 DIP Switch Settings



C10815

Fig. 73 - RTU Open Controller Address Switches

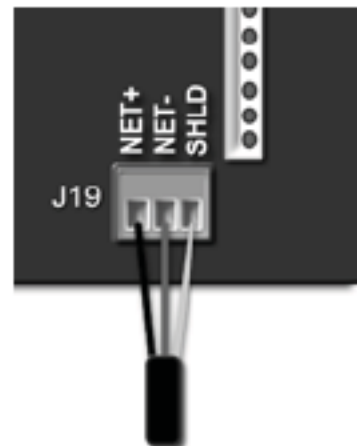

Fig. 74 - Network Wiring

C10816

Field Assistant: Field Assistant is a computer program included with the purchase of the Tech Tool Kit (USB-TKIT). This is a field Tech Tool to set-up, service, or download application software to the RTU Open controller and includes a USB Link Cable. The link cable connects a USB port to the J12 local access port. The Field Assistant’s menu structure is similar and functions the same as i-Vu® controller. See Fig. 75.

RTU Open Controller Troubleshooting —

Communication LEDs: The LEDs indicate if the controller is speaking to the devices on the network. The

LEDs should reflect communication traffic based on the baud rate set. The higher the baud rate the more solid the LEDs will appear. See Table 28.

NOTE: Refer to the *RTU Open Multi-Protocol Controller Controls, Start-Up, Operation and Troubleshooting* manual for complete configuration of the RTU Open controller, operating sequences and troubleshooting information. Refer to the *RTU Open v3 Integration Guide* for details on configuration and troubleshooting of connected networks. Have a copy of these manuals available at unit start-up.

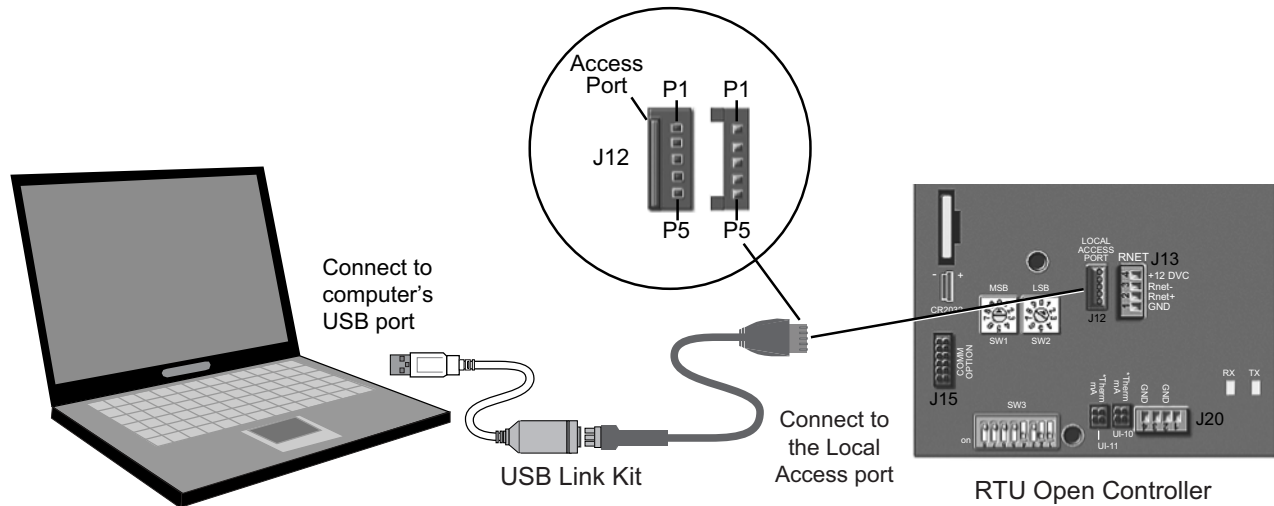

Fig. 75 - PC Running Field Assistant

C14131

Table 28 – LEDs

The LEDs on the RTU Open controller show the status of certain functions

| If this LED is on... | Status is... |
|----------------------|---|
| Power | The RTU Open controller has power |
| Rx | The RTU Open controller is receiving data from the network segment |
| Tx | The RTU Open controller is transmitting data over the network segment |
| BO# | The binary output is active |

The **Run** and **Error** LEDs indicate control module and network status

| If Run LED shows... | And Error LED shows... | Status is... |
|-----------------------|--|--|
| 2 flashes per second | Off | Normal |
| 2 flashes per second | 2 flashes, alternating with Run LED | Five minute auto–restart delay after system error |
| 2 flashes per second | 3 flashes, then off | Control module has just been formatted |
| 2 flashes per second | 4 flashes, then pause | Two or more devices on this network have the same MSTP network address |
| 2 flashes per second | On | Exec halted after frequent system errors or control programs halted |
| 5 flashes per second | On | Exec start–up aborted, Boot is running |
| 5 flashes per second | Off | Firmware transfer in progress, Boot is running |
| 7 flashes per second | 7 flashes per second, alternating with Run LED | Ten second recovery period after brownout |
| 14 flashes per second | 14 flashes per second, alternating with Run LED | Brownout |
| On | On | Failure. Try the following solutions: <ul style="list-style-type: none"> • Turn the RTU Open controller off, then on. • Format the RTU Open controller. • Download memory to the RTU Open controller. • Replace the RTU Open controller. |

Outdoor Air Enthalpy Control (P/N 33CSENTHSW)

The enthalpy control (33CSENTHSW) is available as a field-installed accessory to be used with the EconoMiSer® 2 damper system. The outdoor air enthalpy sensor is part of the enthalpy control. (The separate field-installed accessory return air enthalpy sensor (33CSENTSEN) is required for differential enthalpy control. See Fig. 76.)

Locate the enthalpy control in the economizer next to the Actuator Motor. Locate two GRA leads in the factory harness and connect the gray lead labeled “ESL” to the terminal labeled “LOW”. See Fig. 76. Connect the enthalpy control power input terminals to economizer actuator power leads RED (connect to 24V) and BLK (connect to GND).

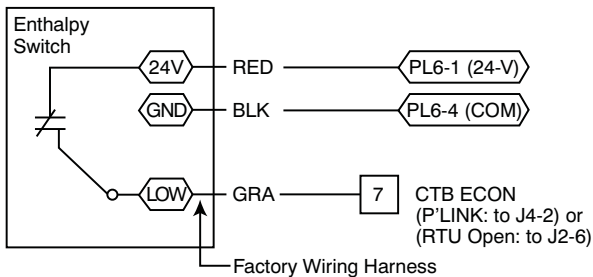

C11160

Fig. 76 - Enthalpy Switch (33CSENTHSW) Connections

The outdoor enthalpy changeover setpoint is set at the enthalpy controller.

Differential Enthalpy Control —

Differential enthalpy control is provided by sensing and comparing the outside air and return air enthalpy conditions. Install the outdoor air enthalpy control as described above. Add and install a return air enthalpy sensor.

Return Air Enthalpy Sensor —

Mount the return-air enthalpy sensor (33CSENTSEN) in the return-air section of the economizer. The return air sensor is wired to the enthalpy controller (33CSENTHSW). See Fig. 77.

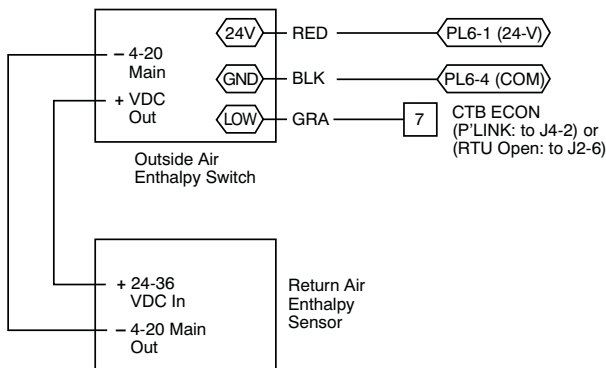

C11161

Fig. 77 - Outside and Return Air Enthalpy Sensor Wiring

Smoke Detectors

Smoke detectors are available as factory-installed options on 50HCQ models. Smoke detectors may be specified for supply air only or for return air without or with economizer or in combination of supply air and return air. All components necessary for operation are factory-provided and mounted. The unit is factory-configured for immediate smoke detector shutdown operation; additional wiring or modifications to unit terminal board may be necessary to complete the unit and smoke detector configuration to meet project requirements.

Units equipped with factory-optional return air smoke detectors require a relocation of the sensor module at unit installation. See Fig. 78 for the as shipped location.

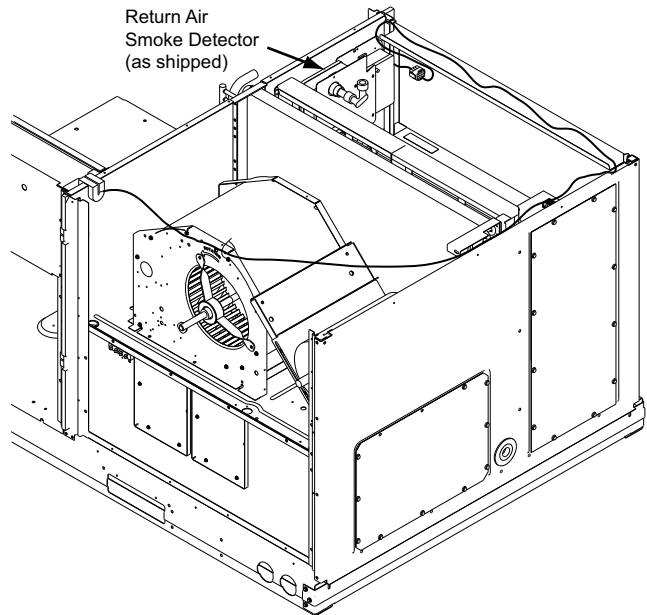

C12282

Fig. 78 - Return Air Smoke Detector, Shipping Position

Completing Installation of Return Air Smoke Sensor:

1. Unscrew the two screws holding the Return Air Smoke Detector assembly. See Fig. 79, Step 1. Save the screws.
2. Turn the assembly 90 degrees and then rotate end to end. Make sure that the elbow fitting is pointing down. See Fig. 79, Step 2.
3. Screw the sensor and detector plate into its operating position using screws from Step 1. See Fig. 79, Step 3.
4. Connect the flexible tube on the sampling inlet to the sampling tube on the basepan.

Additional Application Data: Refer to the Application Data sheet titled Factory Installed Smoke Detectors for Small and Medium Rooftop Units 2 to 25 Tons for discussions on additional control features of these smoke detectors including multiple unit coordination.

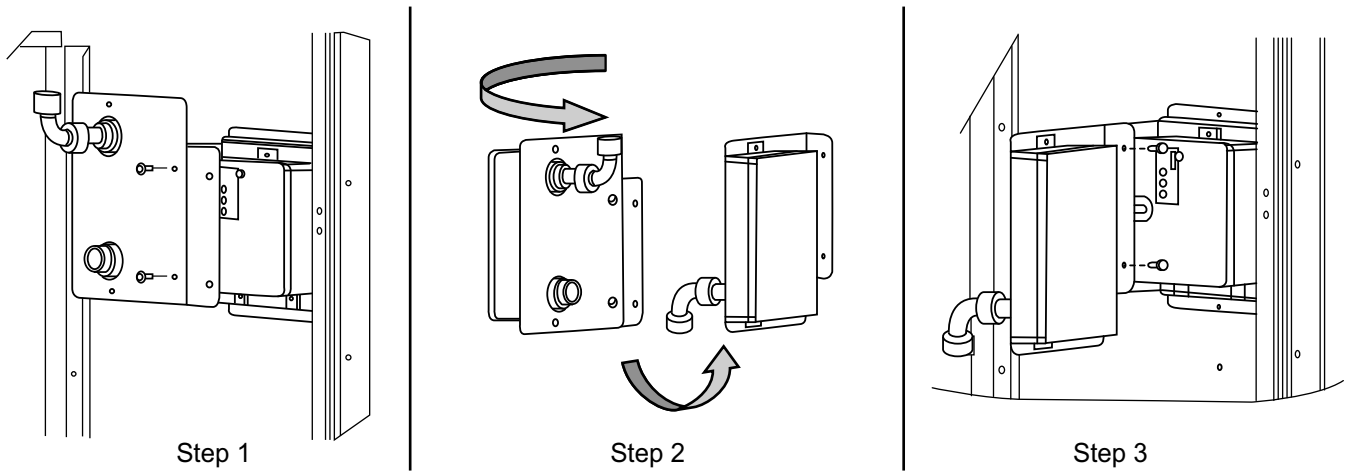

Fig. 79 - Completing Installation of Return Air Smoke Sensor

C12283

Step 11 — Adjust Factory-Installed Options

Smoke Detectors: Smoke detector(s) will be connected at the Central Terminal Board (CTB), at terminals marked “Smoke Shutdown”. Remove jumper JMP 3 when ready to energize unit.

EconoMi\$er® IV Occupancy Switch: Refer to Fig. 80 for general EconoMi\$er IV wiring. External occupancy control is managed through a connection on the Central Terminal Board.

If external occupancy control is desired, connect a time clock or remotely controlled switch (closed for Occupied, open for Unoccupied sequence) at terminals marked OCCUPANCY on CTB. Remove or cut jumper JMP 2 to complete the installation.

Step 12 — Install Accessories

Available accessories include:

- Roof curb
- Thru-base connection kit (must be installed before unit is set on curb)
- Manual outside air damper
- Two-position motorized outside air damper
- EconoMi\$er IV (with control and integrated barometric relief)
- EconoMi\$er 2 (without control/for external signal and integrated barometric relief)
- Power exhaust
- Differential dry-bulb sensor (EconoMi\$er IV)
- Outdoor enthalpy sensor

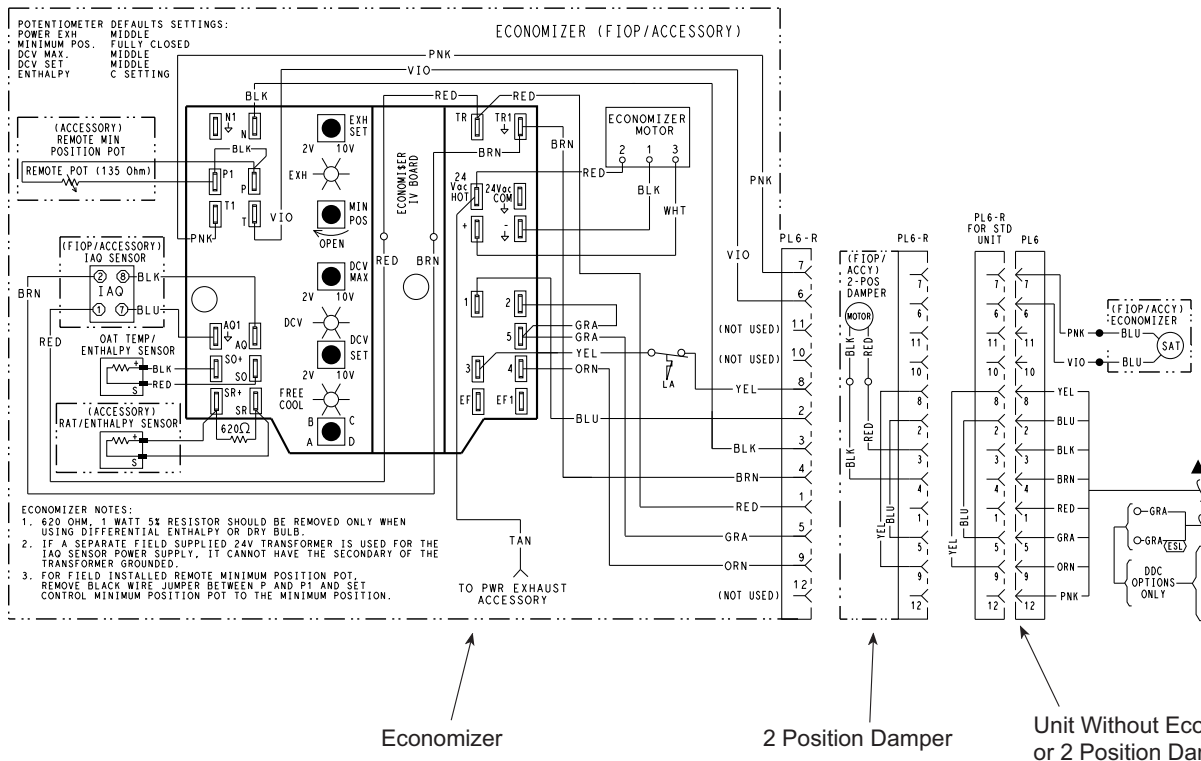

Fig. 80 - EconoMi\$er IV Wiring

C160126

- Differential enthalpy sensor
- Time Guard II compressor anti-cycle control
- Head pressure control
- Programmable setback thermostat
- Electro-mechanical thermostat and subbase
- Electric heaters
- Single point kits
- Thermostat / Sensors
- CO₂ sensor
- DDC interface (PremierLink™ controller)
- Louvered hail guard
- Phase monitor control

Refer to separate installation instructions for information on installing these accessories.

Step 13 — Check Belt Tension

Measure the belt span length as shown in Fig. 81. Calculate the required deflection by multiplying the belt span length by $\frac{1}{64}$. For example, if the belt span length is 32 inches: $32 \times \frac{1}{64} = \frac{1}{2}$ inch deflection.

Belt Force - Deflection Method -

Check the belt tension with a spring-force belt force deflection gauge.

1. Place a straightedge along the belt between the two pulleys. Measure the distance between the motor shaft and the blower shaft.
2. Set the tension gauge to the desired tension (see Table 1 in Fig. 81). Place the large O-ring at that point.
3. Press the tension checker downward on the belt until the large O-ring is at the bottom of the straightedge.
4. Adjust the belt tension as needed.

Adjust belt tension by loosening the motor mounting plate front bolts and rear bolt (see Fig. 82) and sliding the plate towards the fan (to reduce tension) or away from the fan (to increase tension). Ensure the blower shaft and motor shaft are parallel to each other (pulleys aligned). Tighten all bolts securely when finished.

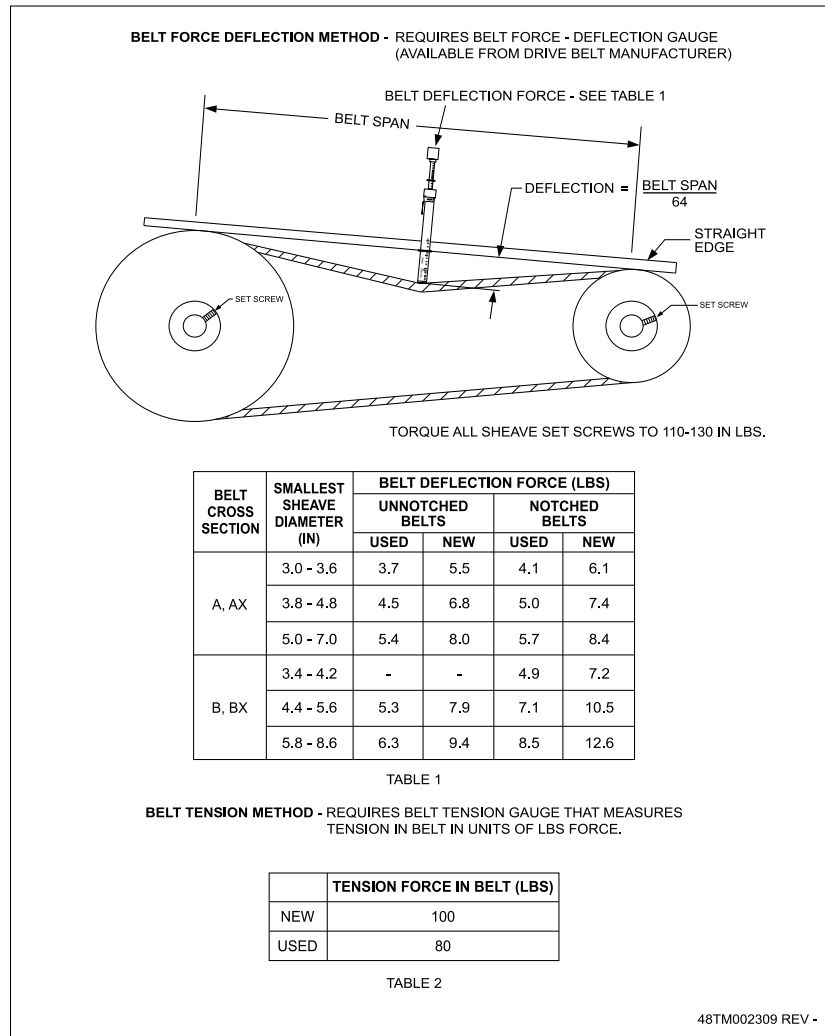

Fig. 81 - V-Belt Force Label

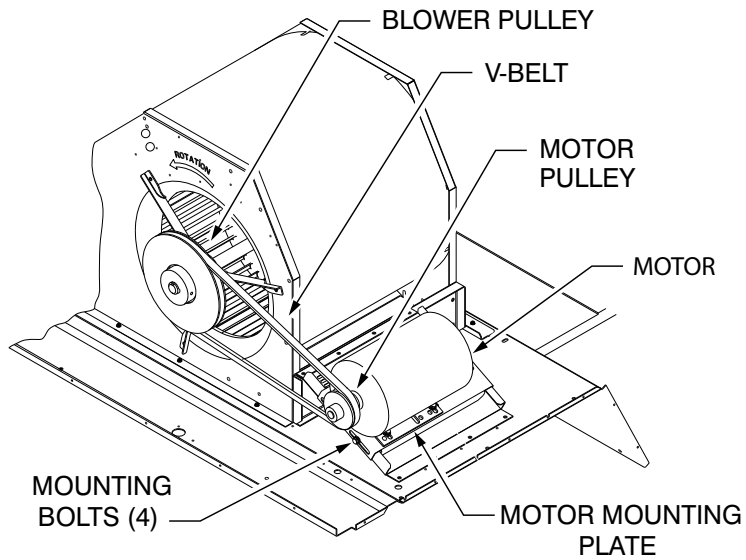

Fig. 82 - Belt Drive Motor Mounting

C11504

Pre-Start and Start-Up

This completes the mechanical installation of the unit. Refer to the unit's Service Manual for detailed Pre-Start and Start-Up instructions. Download the latest versions from HVAC Partners (www.hvacpartners.com).

UNIT START-UP CHECKLIST

(Remove and Store in Job File)

NOTE: To avoid injury to personnel and damage to equipment or property when completing the procedures listed in this start-up checklist, use good judgement, follow safe practices, and adhere to the safety considerations/information as outlined in the preceding sections of this Installation Instructions document.

MODEL NO.: _____

SERIAL NO.: _____

I. PRE-START-UP

- VERIFY THAT ALL PACKAGING MATERIALS HAVE BEEN REMOVED FROM UNIT
- VERIFY INSTALLATION OF OUTDOOR AIR HOOD
- VERIFY THAT CONDENSATE CONNECTION IS INSTALLED PER INSTRUCTIONS
- VERIFY THAT ALL ELECTRICAL CONNECTIONS AND TERMINALS ARE TIGHT
- CHECK THAT INDOOR-AIR FILTERS ARE CLEAN AND IN PLACE
- CHECK THAT OUTDOOR AIR INLET SCREENS ARE IN PLACE
- VERIFY THAT UNIT IS LEVEL
- CHECK FAN WHEELS AND PROPELLER FOR LOCATION IN HOUSING/ORIFICE AND VERIFY SETSCREW IS TIGHT
- VERIFY THAT FAN SHEAVES ARE ALIGNED AND BELTS ARE PROPERLY TENSIONED
- VERIFY THAT SCROLL COMPRESSORS ARE ROTATING IN THE CORRECT DIRECTION
- VERIFY INSTALLATION OF THERMOSTAT

II. START-UP

COOLING CYCLE —

ELECTRICAL

| | | | |
|-------------------|-------------|-------------|-------------|
| SUPPLY VOLTAGE | L1-L2 _____ | L2-L3 _____ | L3-L1 _____ |
| COMPRESSOR AMPS 1 | L1 _____ | L2 _____ | L3 _____ |
| COMPRESSOR AMPS 2 | L1 _____ | L2 _____ | L3 _____ |
| SUPPLY FAN AMPS | L1 _____ | L2 _____ | L3 _____ |

TEMPERATURES

OUTDOOR-AIR TEMPERATURE _____ °F DB (DRY BULB)

RETURN-AIR TEMPERATURE _____ °F DB _____ °F WB (WET BULB)

COOLING SUPPLY AIR TEMPERATURE _____ °F

PRESSURES

| | |
|-----------------------|----------------------|
| REFRIGERANT SUCTION | CIRCUIT A _____ PSIG |
| | CIRCUIT B _____ PSIG |
| REFRIGERANT DISCHARGE | CIRCUIT A _____ PSIG |
| | CIRCUIT B _____ PSIG |

- VERIFY REFRIGERANT CHARGE USING CHARGING CHARTS

HEATING CYCLE —

ELECTRICAL

| | | | |
|-------------------|-------------|-------------|-------------|
| SUPPLY VOLTAGE | L1-L2 _____ | L2-L3 _____ | L3-L1 _____ |
| COMPRESSOR AMPS 1 | L1 _____ | L2 _____ | L3 _____ |
| COMPRESSOR AMPS 2 | L1 _____ | L2 _____ | L3 _____ |
| SUPPLY FAN AMPS | L1 _____ | L2 _____ | L3 _____ |

