

# Installation Instructions

**NOTE:** Read the entire instruction manual before starting the installation

## TABLE OF CONTENTS

SAFETY CONSIDERATIONS .....	1
INSTALLATION .....	5
Step 1 - Plan for Unit Location .....	5
Step 2 - Plan for Sequence of Unit Installation .....	5
Step 3 - Inspect Unit .....	6
Step 4 - Provide Unit Support .....	6
Step 5 - Field Fabricate Ductwork .....	8
Step 6 - Rig and Place Unit .....	8
Step 7 - Convert to Horizontal and Connect Ductwork .....	9
Step 8 - Install Outside Air Hood .....	9
Step 9 - Install External Condensate Trap and Piping .....	11
Step 10 - Make Electrical Connections .....	11
Step 11 - Humidi-MiZer™ — Space RH Controller .....	37
Step 12 - Adjust Factory-Installed Options .....	43
Step 13 - Install Accessories .....	43

## SAFETY CONSIDERATIONS

Improper installation, adjustment, alteration, service, maintenance, or use can cause explosion, fire, electrical shock or other conditions which may cause personal injury or property damage. Consult a qualified installer, service agency, or your distributor or branch for information or assistance. The qualified installer or agency must use factory-authorized kits or accessories when modifying this product. Refer to the individual instructions packaged with the kits or accessories when installing.

Follow all safety codes. Wear safety glasses and work gloves. Use quenching cloths for brazing operations and have a fire extinguisher available. Read these instructions thoroughly and follow all warnings or cautions attached to the unit. Consult local building codes and appropriate national electrical codes (in USA, ANSI/NFPA 70, National Electrical Code (NEC); in Canada, CSA C22.1) for special requirements.

It is important to recognize safety information. This is the safety-alert symbol . When you see this symbol on the unit and in instructions or manuals, be alert to the potential for personal injury.

Understand the signal words DANGER, WARNING, CAUTION, and NOTE. These words are used with the safety-alert symbol. DANGER identifies the most serious hazards which **will** result in severe personal injury or death. WARNING signifies hazards which **could** result in personal injury or death. CAUTION is used to identify unsafe practices, which **may** result in minor personal injury or product and property damage. NOTE is used to highlight suggestions which **will** result in enhanced installation, reliability, or operation.

**⚠ WARNING**

**ELECTRICAL SHOCK HAZARD**

Failure to follow this warning could cause personal injury or death.

Before performing service or maintenance operations on unit, turn off main power switch to unit and install lockout tag. Ensure electrical service to rooftop unit agrees with voltage and amperage listed on the unit rating plate. Unit may have more than one power switch.

**⚠ WARNING**

**PERSONAL INJURY AND ENVIRONMENTAL HAZARD**

Failure to follow this warning could cause personal injury or death.

Relieve pressure and recover all refrigerant before system repair or final unit disposal.

Wear safety glasses and gloves when handling refrigerants. Keep torches and other ignition sources away from refrigerants and oils.

**⚠ WARNING**

**UNIT OPERATION AND SAFETY HAZARD**

Failure to follow this warning could cause personal injury, death and/or equipment damage.

Puron® (R-410A) refrigerant systems operate at higher pressures than standard R-22 systems. Do not use R-22 service equipment or components on Puron refrigerant equipment.

**⚠ CAUTION**

**CUT HAZARD**

Failure to follow this caution may result in personal injury.

Sheet metal parts may have sharp edges or burrs. Use care and wear appropriate protective clothing, safety glasses and gloves when handling parts and servicing equipment.



50HT

UNIT	STD. UNIT WEIGHT		CORNER WEIGHT (A)		CORNER WEIGHT (B)		CORNER WEIGHT (C)		CORNER WEIGHT (D)		C.G.		HEIGHT
	LBS.	KG.	LBS.	KG.	LBS.	KG.	LBS.	KG.	LBS.	KG.	X	Y	Z
50HT-A07	607	275	150	68	160	73	153	69	144	65	38 [965]	22 [559]	20 3/4 [527]

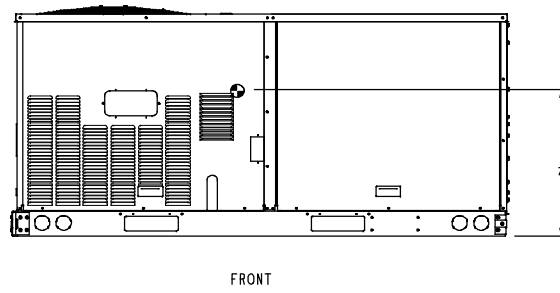
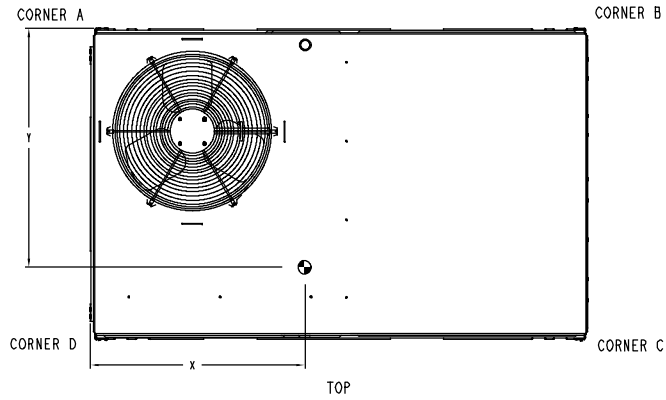

Fig. 1 - Unit Dimensional Drawing (cont.)

C10315

# INSTALLATION

## Jobsite Survey

Complete the following checks before installation.

1. Consult local building codes and the NEC (National Electrical Code) (ANSI/NFPA 70) for special installation requirements.
2. Determine unit location (from project plans) or select unit location.
3. Check for possible overhead obstructions which may interfere with unit lifting or rigging.

### Step 1 — Plan for Unit Location

Select a location for the unit and its support system (curb or other) that provides for minimum clearances required for safety (including clearance to combustible surfaces), unit performance and service access below, around and above unit as specified in unit drawings. See Fig. 2.

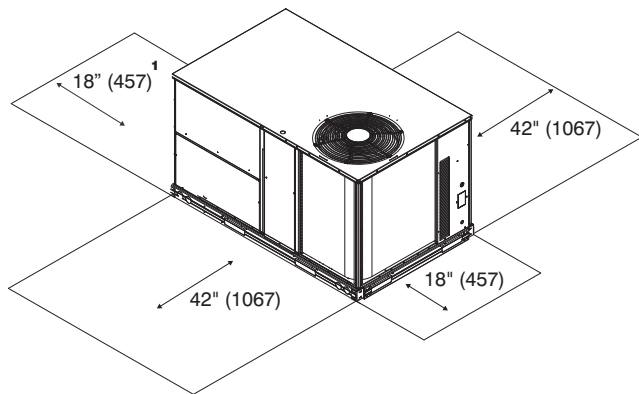

<sup>1</sup> Required bottom condensate drain connection. Otherwise, 36" (914mm) for condensate connection.

C07459

**Fig. 2 - Service Clearance Dimensional Drawing**

**NOTE:** Consider also the effect of adjacent units.

Unit may be installed directly on wood flooring or on Class A, B, or C roof-covering material when roof curb is used.

Do not install unit in an indoor location. Do not locate air inlets near exhaust vents or other sources of contaminated air.

Although unit is weatherproof, avoid locations that permit water from higher level runoff and overhangs to fall onto unit.

Select a unit mounting system that provides adequate height to allow installation of condensate trap per requirements. Refer to Step 9 — Install External Trap for Condensate Drain – for required trap dimensions.

### Roof mount —

Check building codes for weight distribution requirements. Unit operating weight is shown in Table 1.

### Step 2 — Plan for Sequence of Unit Installation

The support method used for this unit will dictate different sequences for the steps of unit installation. For example, on curb-mounted units, some accessories must be

installed on the unit before the unit is placed on the curb. Review the following for recommended sequences for installation steps.

### Curb-mounted installation —

- Install curb
- Install field-fabricated ductwork inside curb
- Install accessory thru-base service connection package (affects curb and unit) (refer to accessory installation instructions for details)
- Prepare bottom condensate drain connection to suit planned condensate line routing (refer to Step 9 for details)
- Rig and place unit
- Install outdoor air hood
- Install condensate line trap and piping
- Make electrical connections
- Install other accessories

**Table 1 – Operating Weights**

50HT	UNITS LB (KG)
Component	A07
Base Unit	610 (277)
Economizer	
Vertical	50 (23)
Horizontal	80 (36)
Humidi-MiZer™ System	41 (15)
Cu Fins	73 (33)
Powered Outlet	32 (15)
Curb	
14-in/356 mm	110 (50)
24-in/610 mm	145 (66)

### Curb-mounted installation —

- Install curb
- Install field-fabricated ductwork inside curb
- Install accessory thru-base service connection package (affects curb and unit) (refer to accessory installation instructions for details)
- Prepare bottom condensate drain connection to suit planned condensate line routing (refer to Step 9 for details)
- Rig and place unit
- Install outdoor air hood
- Install condensate line trap and piping
- Make electrical connections
- Install other accessories

### Pad-mounted installation —

- Prepare pad and unit supports
- Check and tighten the bottom condensate drain connection plug
- Rig and place unit
- Convert unit to side duct connection arrangement
- Install field-fabricated ductwork at unit duct openings
- Install outdoor air hood
- Install condensate line trap and piping

50HT

- Make electrical connections
- Install other accessories

**Frame-mounted installation —**

Frame-mounted applications generally follow the sequence for a curb installation. Adapt as required to suit specific installation plan.

**Step 3 — Inspect unit**

Inspect unit for transportation damage. File any claim with transportation agency.

Confirm before installation of unit that voltage, amperage and circuit protection requirements listed on unit data plate agree with power supply provided.

**Step 4 — Provide Unit Support**

**Roof Curb Mount**

Accessory roof curb details and dimensions are shown in Fig. 3. Assemble and install accessory roof curb in accordance with instructions shipped with the curb.

Curb should be level. This is necessary for unit drain to function properly. Unit leveling tolerances are shown in Fig. 4. Refer to Accessory Roof Curb Installation Instructions for additional information as required.

Install insulation, cant strips, roofing felt, and counter flashing as shown. *Ductwork must be attached to curb and not to the unit. The accessory thru-the-base power and gas connection package must be installed before the unit is set on the roof curb.*

If electric and control wiring is to be routed through the basepan, attach the accessory thru-the-base service connections to the basepan in accordance with the accessory installation instructions.

**NOTE:** The gasketing of the unit to the roof curb is critical for a watertight seal. Install gasket supplied with the roof curb as shown in Fig. 3. Improperly applied gasket can also result in air leaks and poor unit performance.

**Slab Mount (Horizontal Units Only)**

Provide a level concrete slab that extends a minimum of 6 in. (150 mm) beyond unit cabinet. Install a gravel apron in front of condenser coil air inlet to prevent grass and foliage from obstructing airflow.

**NOTE:** Horizontal units may be installed on a roof curb if required.

**Alternate Unit Support (Curb or Slab Mount)**

A non-combustible sleeper rail can be used in the unit curb support area. If sleeper rails cannot be used, support the long sides of the unit with a minimum of 3 equally spaced 4-in. x 4-in. (102 mm x 102 mm) pads on each side.

CONNECTOR PKG. ACCY.	B in. [mm]	C in. [mm]	D ALT DRAIN HOLE in. [mm]	POWER	CONTROL	ACCESSORY POWER
CRBTMPWR003A01	1-9 <sup>11/16</sup> [551]	1-4 [406]	1 <sup>3/4</sup> [44.5]	3/4 [19] NPT	1/2 [12.7] NPT	1/2 [12.7] NPT
CRBTMPWR004A01				1 1/4 [31.7]		

ROOF CURB ACCESSORY	A in. [mm]	UNIT SIZE
CRRFCURB001A01	1-2 [356]	50HTA07
CRRFCURB002A01	2-0 [610]	

**NOTES:**

1. Roof curb accessory is shipped disassembled.
2. Insulated panels.
3. Dimensions in [ ] are in millimeters.
4. Roof curb: galvanized steel.
5. Attach ductwork to curb (flanges of duct rest on curb).
6. Service clearance: 4 ft on each side.
7.  Direction of airflow.

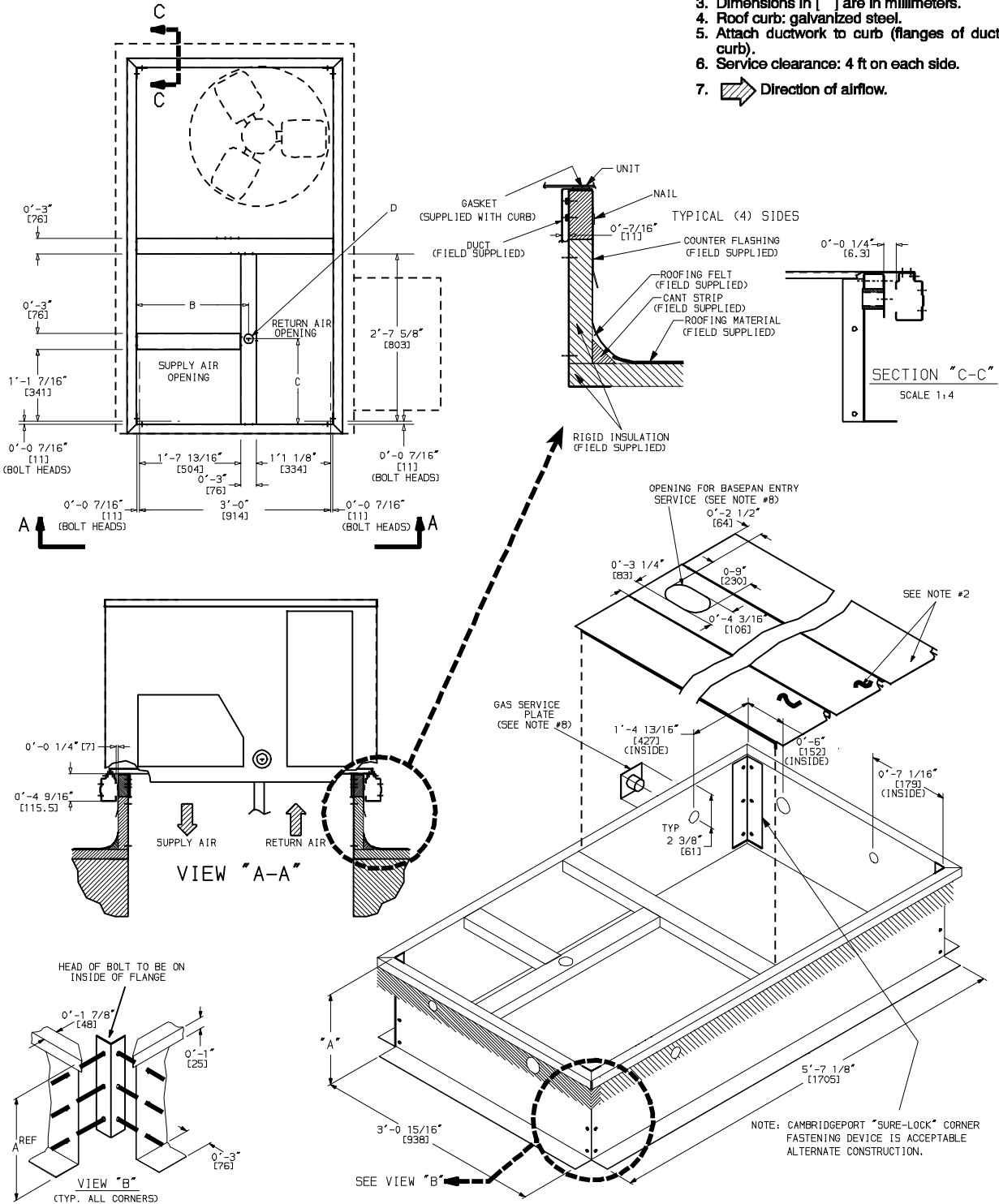

50HT

**Fig. 3 - Roof Curb Details**

C10316

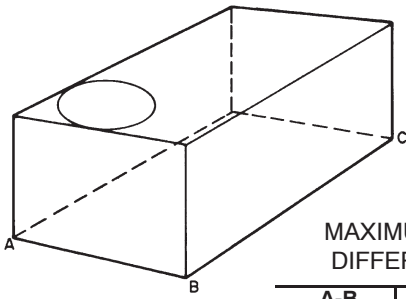

MAXIMUM ALLOWABLE DIFFERENCE IN. (MM)

A-B	B-C	A-C
0.5" (13)	1.0" (25)	1.0" (25)

C06110

Fig. 4 - Unit Leveling Tolerances

### Step 5 — Field Fabricate Ductwork

Cabinet return-air static pressure (a negative condition) shall not exceed 0.35 in. wg (87 Pa) with economizer or 0.45 in. wg (112 Pa) without economizer.

For vertical ducted applications, secure all ducts to roof curb and building structure on vertical ducted units. *Do not connect ductwork to unit.*

Insulate and weatherproof all external ductwork, joints, and roof openings with counter flashing and mastic in accordance with applicable codes.

Ducts passing through unconditioned spaces must be insulated and covered with a vapor barrier.

If a plenum return is used on a vertical unit, the return should be ducted through the roof deck to comply with applicable fire codes.

For units with accessory electric heaters: Horizontal applications require a minimum clearance to combustible surfaces of 1-in (25 mm) from duct for first 12-in (305 mm) away from unit. Vertical applications do not require a minimum clearance around ductwork

### Step 6 — Rig and Place Unit

Keep unit upright and do not drop. Spreader bars must be used when lifting the unit, even when the top crate remains in place. Rollers may be used to move unit across a roof. Level by using unit frame as a reference. See Table 1 and Fig. 5 for additional information.

Lifting holes are provided in base rails as shown in Fig5. Refer to rigging instructions on unit.

Before setting the unit onto the curb, recheck gasketing on curb.

50HT

## ▲ CAUTION

### UNIT DAMAGE HAZARD

Failure to follow this caution may result in equipment damage.

All panels must be in place when rigging. Unit is not designed for handling by fork truck.

If using top crate as spreader bar, once unit is set, carefully lower wooden crate off building roof top to ground. Ensure that no people or obstructions are below prior to lowering the crate.

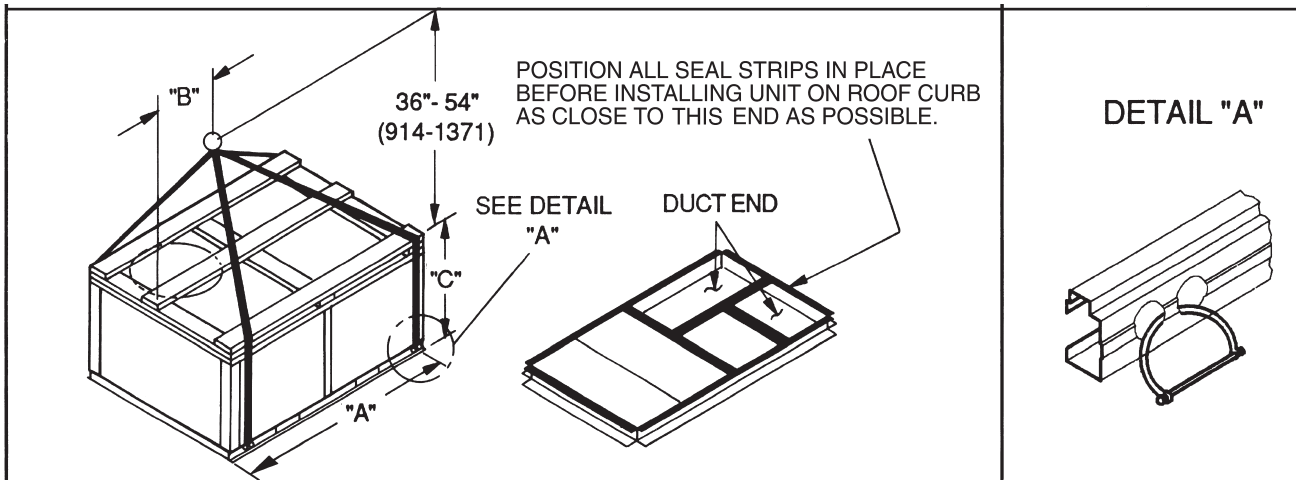

C06005

UNIT	MAX WEIGHT		DIMENSION					
			A		B		C	
	LB	KG	IN	MM	IN	MM	IN	MM
50HT-A07	645	293	74.38	1888	38	965	41.38	1051

#### NOTES:

1. Dimensions in ( ) are in millimeters.
2. Hook rigging shackles through holes in base rail, as shown in detail "A". Holes in base rails are centered around the unit center of gravity. Use wooden top to prevent rigging straps from damaging unit.
3. Unit weights do not include economizer.

Fig. 5 - Rigging Details



## Positioning on Curb —

Position unit on roof curb so that the following clearances are maintained: 1/4 in. (6.4 mm) clearance between the roof curb and the base rail inside the front and rear, 0.0 in. clearance between the roof curb and the base rail inside on the duct end of the unit. This will result in the distance between the roof curb and the base rail inside on the condenser end of the unit being approximately equal to Fig. 3, section C-C.

Although unit is weatherproof, guard against water from higher level runoff and overhangs.

## ⚠ CAUTION

### UNIT DAMAGE HAZARD

Failure to follow this caution may result in equipment damage.

All panels must be in place when rigging. Unit is not designed for handling by fork truck.

After unit is in position, remove rigging skids and shipping materials.

## Step 7 — Convert to Horizontal and Connect Ductwork (when required)

Unit is shipped in the vertical duct configuration. Unit without factory-installed economizer or return air smoke detector option may be field-converted to horizontal ducted configuration. To convert to horizontal configuration, remove screws from side duct opening covers and remove covers. Using the same screws, install covers on vertical duct openings with the insulation-side down. Seals around duct openings must be tight. See Fig. 6.

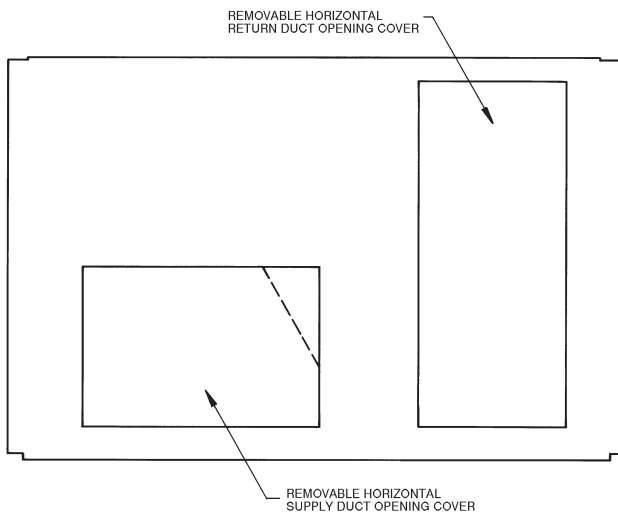

Fig. 6 - Horizontal Conversion Panels

Field-supplied flanges should be attached to horizontal duct openings and all ductwork should be secured to the

flanges. Insulate and weatherproof all external ductwork, joints, and roof or building openings with counter flashing and mastic in accordance with applicable codes.

Do not cover or obscure visibility to the unit's informative data plate when insulating horizontal ductwork.

## Step 8 — Install Outside Air Hood Economizer Hood Removal and Setup - Factory Option

1. The hood is shipped in knock-down form and located in the return air compartment. It is attached to the economizer using two plastic tie-wraps.
2. To gain access to the hood, remove the filter access panel. (See Fig. 7.)
3. Locate and cut the (2) plastic tie-wraps, being careful to not damage any wiring. (See Fig. 9.)
4. Carefully lift the hood assembly through the filter access opening and assemble per the Unit Installation Instruction.

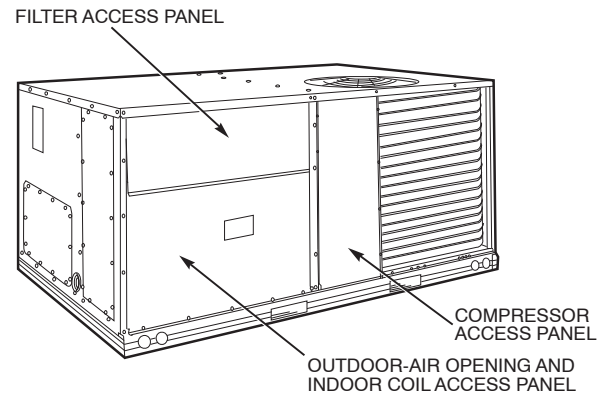

Fig. 7 - Typical Access Panel Locations

## Two Position Damper Hood Removal and Setup - Factory Option

1. The hood is shipped in knock-down form and assembled to a metal support tray using plastic stretch wrap. Located in the return air compartment, the assembly's metal tray is attached to the basepan and also attached to the damper using two plastic tie-wraps.
2. To gain access to the hood, remove the filter access panel. (See Fig. 7.)
3. Locate the (2) screws holding the metal tray to the basepan and remove. Locate and cut the (2) plastic tie-wraps securing the assembly to the damper. (See Fig. 10.) Be careful to not damage any wiring or cut tie-wraps securing any wiring.
4. Carefully lift the hood assembly (with metal tray) through the filter access opening and assemble per steps outlined in the Economizer Hood and Two Position Hood.

**NOTE:** Refer to Fig. 8 for EconoMi\$er IV wiring instead of what is shown in unit installation instructions.

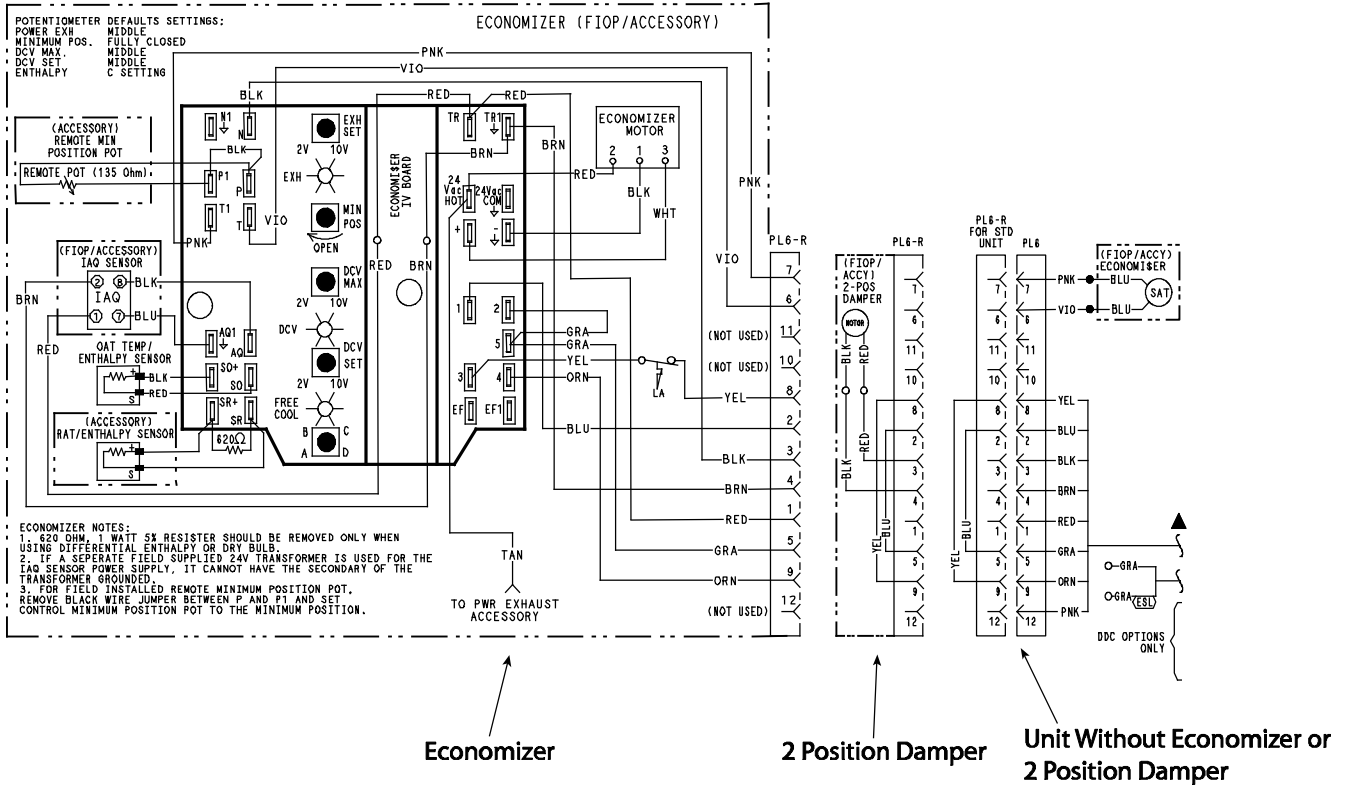

Fig. 8 - Economizer Wiring

C08631

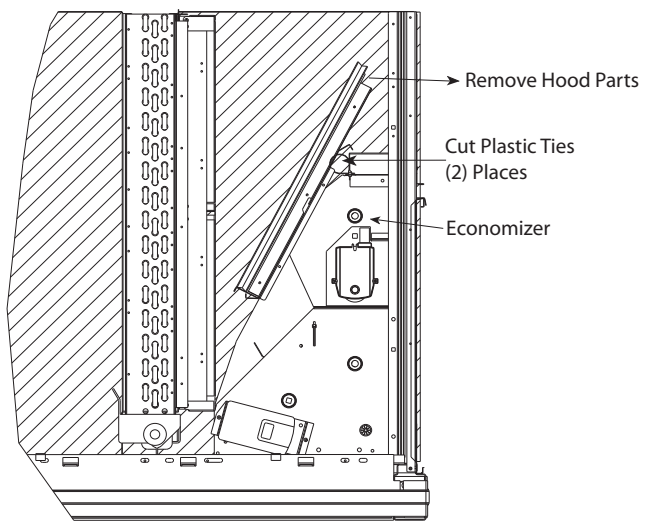

Fig. 9 - Economizer Hood Removal

C08633

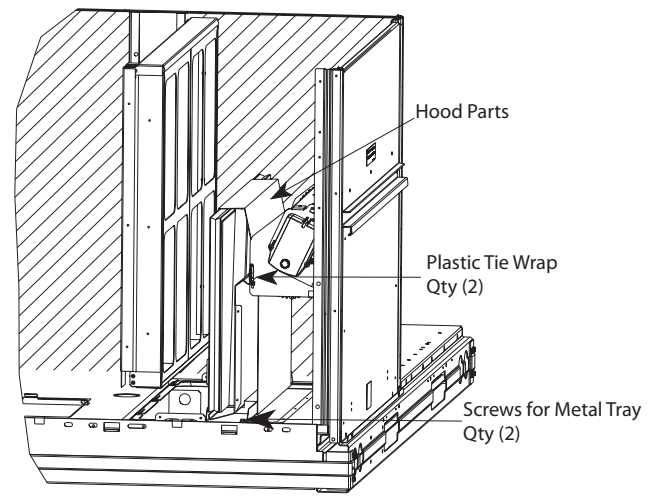
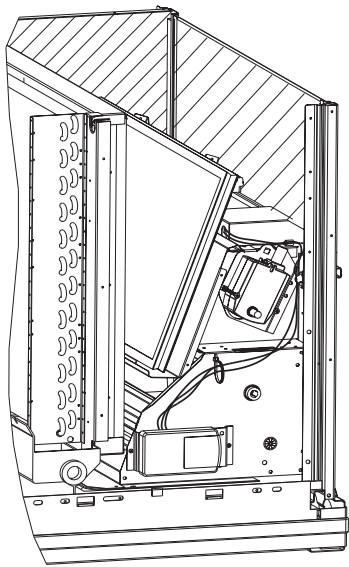

Fig. 10 - Damper Assembly

C08639

**CO<sub>2</sub> Sensor - Factory Option**

1. CO<sub>2</sub> sensor is now a factory option and must be used with an economizer.
2. The CO<sub>2</sub> sensor is located on the lower side of the economizer. (See Fig. 11.)
3. If additional installation and operating instructions are required for the CO<sub>2</sub> sensor, please reference installation instruction 48/50H,P-20SI.



IAQ (CO2) SENSOR ASY 04-07

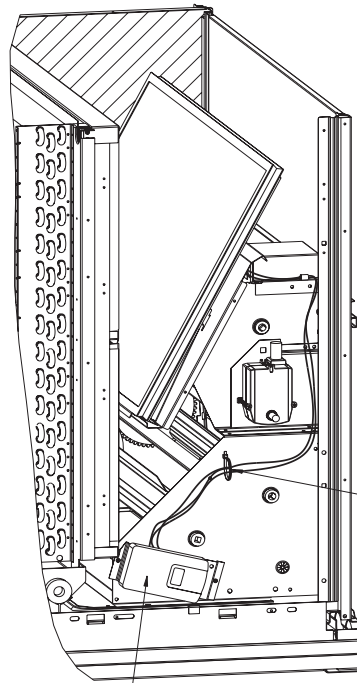

IAQ (CO2) SENSOR ASY 08-12

1 4  
3  
CO2 Sensor

6 Sensor Wiring

Fig. 11 - CO<sub>2</sub> Sensor Location

C08632

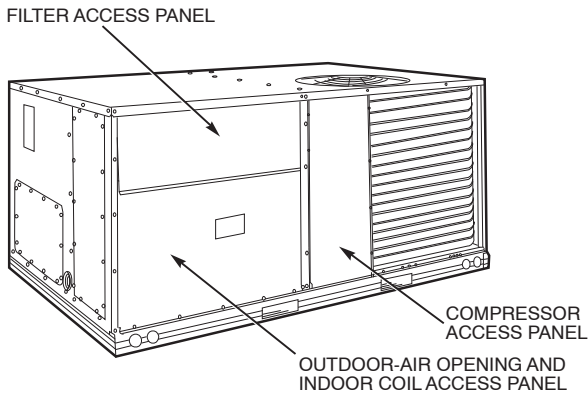
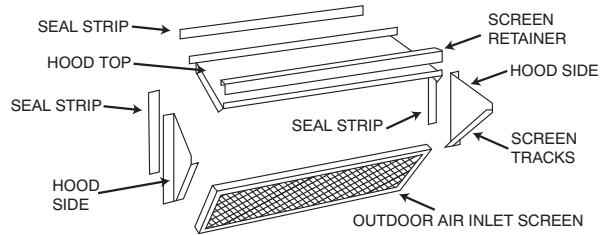
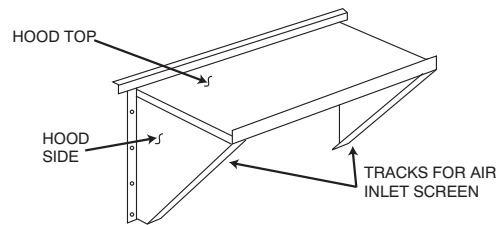

Fig. 12 - Typical Access Panel Locations

C06023



OUTDOOR-AIR HOOD - UNASSEMBLED



HOOD SIDES AND TOP ASSEMBLED

Fig. 13 - Outdoor-Air Hood Details

C07504

**Motorized 2-Position Damper Hood —**

1. Assemble outdoor-air hood top and side plates as shown in Fig. 13. Install seal strips on hood top and sides. Put aside screen retainer and screws for later assembly.
2. Fasten hood top and side plate assembly to unit with screws provided.
3. Slide outdoor-air screen into screen track on hood side plates. While holding screen in place, fasten screen retainer to hood using screws provided.
4. Replace filter access panel. See Fig. 12.

**Economizer Hood —**

**NOTE:** If the power exhaust accessory is to be installed on the unit, the hood shipped with the unit will not be used and must be discarded. Save the aluminum filter for use in the power exhaust hood assembly.

1. The indoor coil access panel will be used as the top of the hood. Remove the screws along the sides and bottom of the indoor coil access panel. See Fig. 14.
2. Swing out indoor coil access panel and insert the hood sides under the panel (hood top). Use the screws provided to attach the hood sides to the hood top. Use screws provided to attach the hood sides to the unit. See Fig. 15.
3. Remove the shipping tape holding the economizer barometric relief damper in place.
4. Insert the hood divider between the hood sides. See Fig. 15 and 16. Secure hood divider with 2 screws on each hood side. The hood divider is also used as the bottom filter rack for the aluminum filter.
5. Open the filter clips which are located underneath the hood top. Insert the aluminum filter into the bottom filter rack (hood divider). Push the filter into position past the open filter clips. Close the filter clips to lock the filter into place. See Fig. 16.
6. Caulk the ends of the joint between the unit top panel and the hood top. See Fig. 14.
7. Replace the filter access panel.

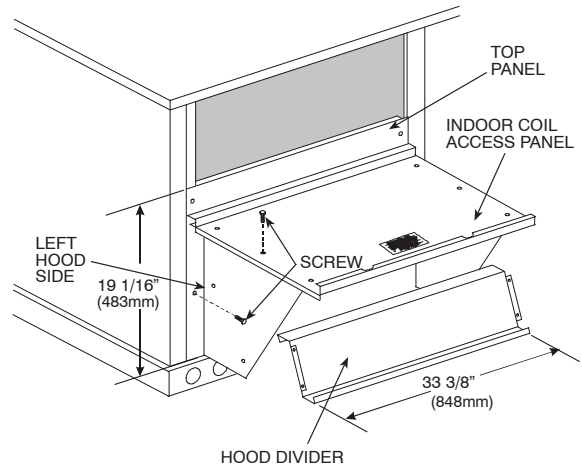

C06026

**Fig. 15 - Economizer Hood Construction**

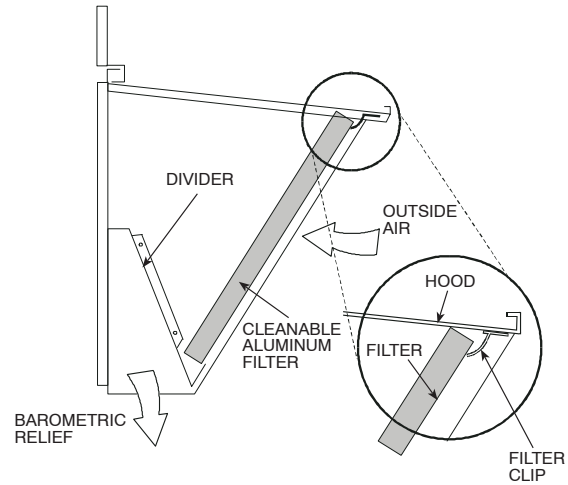

C06027

**Fig. 16 - Economizer Filter Installation**

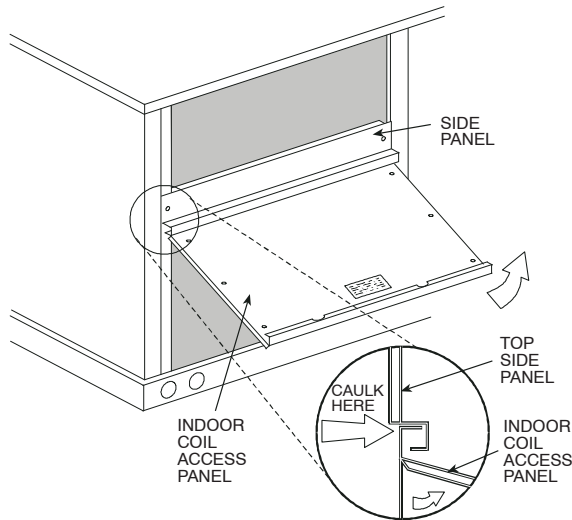

C06025

**Fig. 14 - Indoor Coil Access Panel Relocation**

## Step 9 — Install External Condensate Trap and Line

The unit has one  $\frac{3}{4}$ -in. condensate drain connection on the end of the condensate pan and an alternate connection on the bottom. See Fig. 17. Unit airflow configuration does not determine which drain connection to use. Either drain connection can be used with vertical or horizontal applications.

When using the standard side drain connection, ensure the red plug in the alternate bottom connection is tight. Do this before setting the unit in place. The red drain pan can be tightened with a  $\frac{1}{2}$ -in. square socket drive extension.

To use the alternate bottom drain connection, remove the red drain plug from the bottom connection (use a  $\frac{1}{2}$ -in. square socket drive extension) and install it in the side drain connection.

The piping for the condensate drain and external trap can be completed after the unit is in place. See Fig. 18.

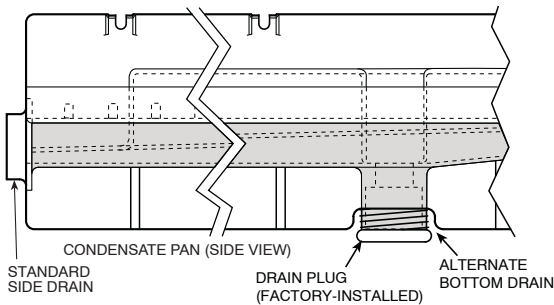

C08021

Fig. 17 - Condensate Drain Pan (Side View)

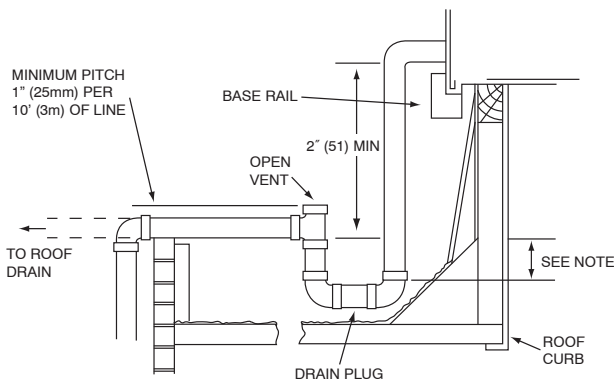

C08022

Fig. 18 - Condensate Drain Piping Details

*All units must have an external trap for condensate drainage. Install a trap at least 4-in. (102 mm) deep and protect against freeze-up. If drain line is installed downstream from the external trap, pitch the line away from the unit at 1-in. per 10 ft (25 mm in 3 m) of run. Do not use a pipe size smaller than the unit connection ( $\frac{3}{4}$ -in.).*

## Step 10 — Make Electrical Connections

### ⚠ WARNING

#### ELECTRICAL SHOCK HAZARD

Failure to follow this warning could result in personal injury or death.

Unit cabinet must have an uninterrupted, unbroken electrical ground to minimize the possibility of personal injury if an electrical fault should occur. This ground may consist of electrical wire connected to unit ground lug in control compartment, or conduit approved for electrical ground when installed in accordance with NEC; ANSI/NFPA 70, latest edition (in Canada, Canadian Electrical Code CSA [Canadian Standards Association] C22.1), and local electrical codes.

50HT

**NOTE:** Check all factory and field electrical connections for tightness. Field-supplied wiring shall conform with the limitations of 63°F (33°C) rise.

#### Field Power Supply —

If equipped with optional Powered Convenience Outlet: The power source leads to the convenience outlet's transformer primary are not factory connected. Installer must connect these leads according to required operation of the convenience outlet. If an always-energized convenience outlet operation is desired, connect the source leads to the line side of the unit-mounted disconnect. (Check with local codes to ensure this method is acceptable in your area.) If a de-energize via unit disconnect switch operation of the convenience outlet is desired, connect the source leads to the load side of the unit disconnect. On a unit without a unit-mounted disconnect, connect the source leads to compressor contactor C and indoor fan contactor IFC pressure lugs with unit field power leads.

Refer to Fig. 23 for power transformer connections and the discussion on connecting the convenience outlet on page 15.

Field power wires are connected to the unit at line-side pressure lugs on compressor contactor C and indoor fan contactor IFC (see wiring diagram label for control box component arrangement) or at factory-installed option non-fused disconnect switch. Max wire size is #2 AWG (copper only). (See Fig. 19.)

**NOTE:** TEST LEADS - Unit may be equipped with short leads (pigtails) on the field line connection points on contactor C or optional disconnect switch. These leads are for factory run-test purposes only; remove and discard before connecting field power wires to unit connection points. Make field power connections directly to line connection pressure lugs only.

Units Without Disconnect Option

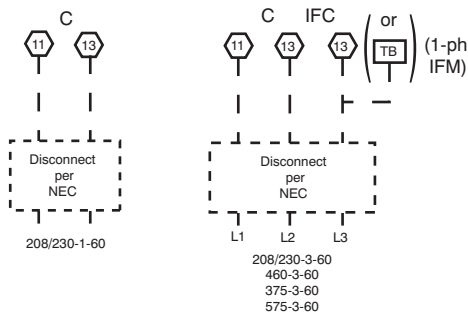

Units With Disconnect Option

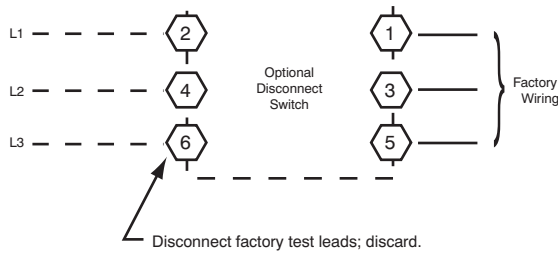

Fig. 19 - Power Wiring Connections

C07494

Units With Factory-Installed Disconnect —

The factory-installed option disconnect switch is located in a weatherproof enclosure located under the main control box. The manual switch handle is accessible through an opening in the access panel. Discard the factory test leads (see Fig. 19).

**⚠ WARNING**

**FIRE HAZARD**

Failure to follow this warning could result in intermittent operation or performance satisfaction.

Do not connect aluminum wire between disconnect switch and 50HT unit. Use only copper wire. (See Fig. 20.)

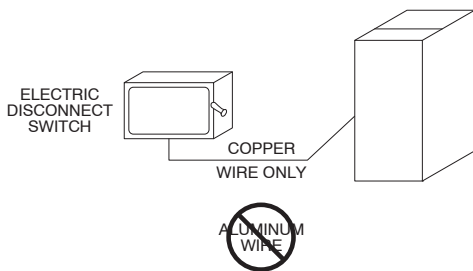

Fig. 20 - Disconnect Switch and Unit

A93033

Units Without Factory-Installed Disconnect —

When installing units, provide a disconnect switch per NEC (National Electrical Code) of adequate size. Disconnect sizing data is provided on the unit informative plate. Locate on unit cabinet or within sight of the unit per national or local codes. Do not cover unit informative plate if mounting the disconnect on the unit cabinet.

All units —

All field wiring must comply with NEC and all local codes. Size wire based on MCA (Minimum Circuit Amps) on the unit informative plate. See Fig. 19 and the unit label diagram for power wiring connections to the unit power terminal blocks and equipment ground. Maximum wire size is #2 ga AWG per pole.

Provide a ground-fault and short-circuit over-current protection device (fuse or breaker) per NEC Article 440 (or local codes). Refer to unit informative data plate for MOCP (Maximum Over-current Protection) device size.

All field wiring must comply with the NEC and local requirements.

All units except 208/230-v units are factory wired for the voltage shown on the nameplate. *If the 208/230-v unit is to be connected to a 208-v power supply, the control transformer must be rewired by moving the black wire with the 1/4-in. female spade connector from the 230-v connection and moving it to the 200-v 1/4-in. male terminal on the primary side of the transformer.* Refer to unit label diagram for additional information. Field power wires will be connected line-side pressure lugs on the power terminal block or at factory-installed option non-fused disconnect.

**NOTE:** Check all factory and field electrical connections for tightness. Field-supplied wiring shall conform with the limitations of 63°F (33°C) rise.

Convenience Outlets —

**⚠ WARNING**

**ELECTRICAL OPERATION HAZARD**

Failure to follow this warning could result in personal injury or death.

Units with convenience outlet circuits may use multiple disconnects. Check convenience outlet for power status before opening unit for service. Locate its disconnect switch, if appropriate, and open it. Tag-out this switch, if necessary.

Two types of convenience outlets are offered on 50HT models: Non-powered and unit-powered. Both types provide a 125-volt GFCI (ground-fault circuit-interrupter) duplex receptacle rated at 15-A behind a hinged waterproof access cover, located on the end panel of the unit. See Fig. 21.

50HT

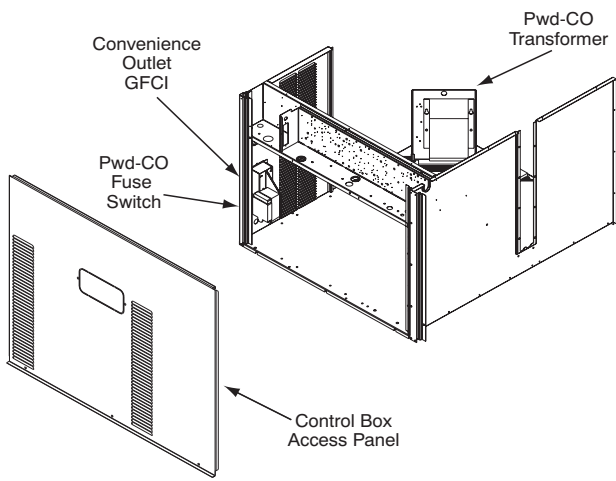

**Fig. 21 - Convenience Outlet Location**

C08128

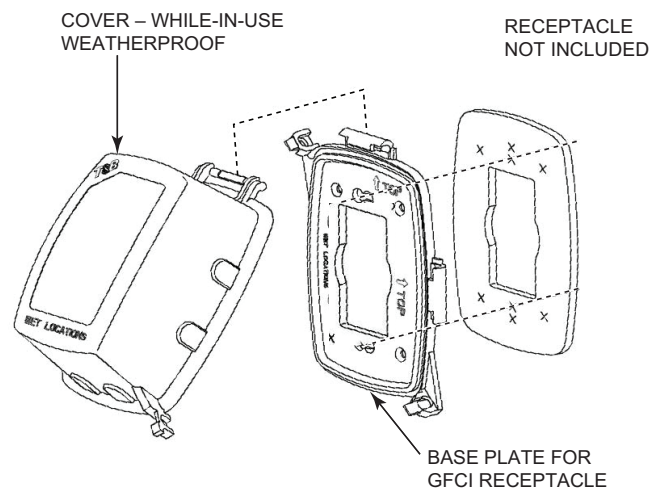

**Fig. 22 - Weatherproof Cover Installation**

C09022

**Installing Weatherproof Cover –**

A weatherproof while-in-use cover for the factory-installed convenience outlets is now required by UL standards. This cover cannot be factory-mounted due its depth; it must be installed at unit installation. For shipment, the convenience outlet is covered with a blank cover plate.

The weatherproof cover kit is shipped in the unit’s control box. The kit includes the hinged cover, a backing plate and gasket.

**DISCONNECT ALL POWER TO UNIT AND CONVENIENCE OUTLET AND INSTALL LOCK OUT TAGS. DEPENDING ON UNIT CONFIGURATION MORE THAN ONE DISCONNECT OR HVACR BREAKER MAY NEED TO BE POWERED OFF.**

Remove the blank cover plate at the convenience outlet; discard the blank cover.

Loosen the two screws at the GFCI duplex outlet, until approximately 1/2-in. (13 mm) under screw heads are exposed. Press the gasket over the screw heads. Slip the backing plate over the screw heads at the keyhole slots and align with the gasket; tighten the two screws until snug (do not over-tighten).

Mount the weatherproof cover to the backing plate as shown in Fig. 22. Remove two slot fillers in the bottom of the cover to permit service tool cords to exit the cover. Check for full closing and latching.

**Non-powered type:** This type requires the field installation of a general-purpose 125-volt 15-A circuit powered from a source elsewhere in the building. Observe national and local codes when selecting wire size, fuse or breaker requirements and disconnect switch size and location. Route 125-v power supply conductors into the bottom of the utility box containing the duplex receptacle.

**Unit-powered type:** A unit-mounted transformer is factory-installed to stepdown the main power supply voltage to the unit to 115-v at the duplex receptacle. This option also includes a manual switch with fuse, located in a utility box and mounted on a bracket behind the convenience outlet; access is through the unit’s control box access panel. See Fig. 22.

The primary leads to the convenience outlet transformer are not factory-connected. Selection of primary power source is a customer-option. If local codes permit, the transformer primary leads can be connected at the line-side terminals on the unit-mounted non-fused disconnect or HACR breaker switch; this will provide service power to the unit when the unit disconnect switch or HACR switch is open. Other connection methods will result in the convenience outlet circuit being de-energized when the unit disconnect or HACR switch is open. See Fig. 23.

50HT

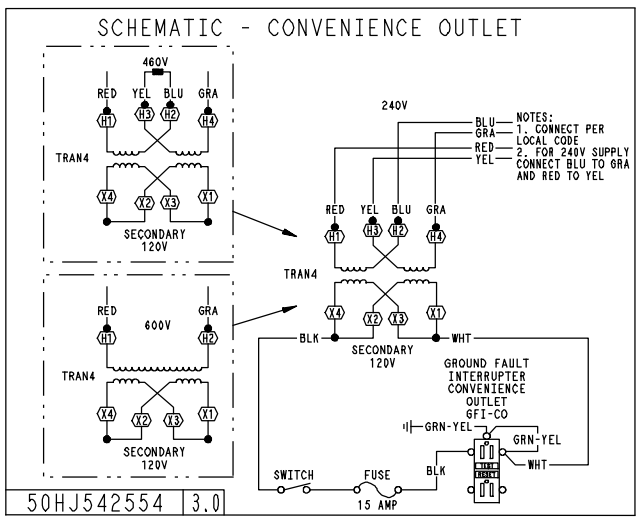

C10305

UNIT VOLTAGE	CONNECT AS	PRIMARY CONNECTIONS	TRANSFORMER TERMINALS
208, 230	240	L1: RED + YEL L2: BLU + GRA	H1 + H3 H2 + H4
460	480	L1: RED L2: Splice BLU + YEL L2: GRA	H1 H2 + H3 H4
575	600	L1: RED L2: GRA	H1 H2

**Fig. 23 - Powered Convenience Outlet Wiring**

Fuse on power type: The factory fuse is a Bussman “Fusetron” T-15, non-renewable screw-in (Edison base) type plug fuse.

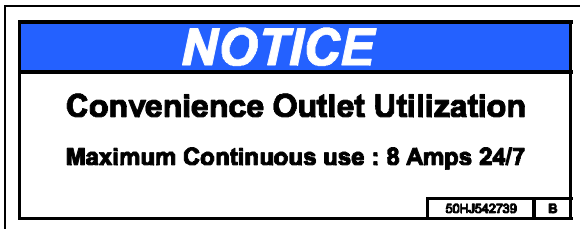

C09247

**Fig. 24 - Convenience Outlet Utilization Notice Label**

Duty Cycle: the unit-powered convenience outlet has a duty cycle limitation. The transformer is intended to provide power on an intermittent basis for service tools, lamps, etc; it is not intended to provide 15-amps loading for continuous duty loads (such as electric heaters for overnight use). Observe a 50% limit on circuit loading above 8-amps.

Convenience outlet usage rating:

Continuous usage: 8 amps maximum

Test the GFCI receptacle by pressing the TEST button on the face of the receptacle to trip and open the receptacle. Check for proper grounding wires and power line phasing if the GFCI receptacle does not trip as required. Press the RESET button to clear the tripped condition.

**Factory-Option Thru-Base Connections —**

Do not install Power and Gas tubing through the base pan of the unit unless the “Thru-Base Connection” kit is used.

Failure to use this kit will result in water leaks through the base pan of the unit, possibly running into the building.

This service connection kit consists of a 1/2-in electrical bulkhead connector and a 3/4-in electrical bulkhead connector, all factory-installed in the embossed (raised) section of the unit basepan in the condenser section. The 3/4-in bulkhead connector enables the low-voltage control wires to pass through the basepan. The 1/2-in electrical bulkhead connector allows the high-voltage power wires to pass through the basepan. See Fig. 25.

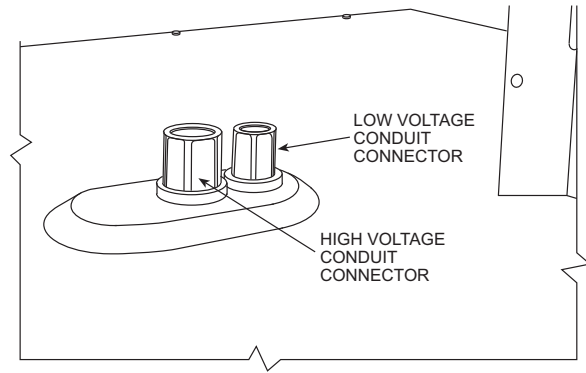

C08637

**Fig. 25 - Thru-Base Connection Fittings**

Check tightness of connector lock nuts before connecting electrical conduits.

Field-supplied and field-installed liquid tight conduit connectors and conduit may be attached to the connectors on the basepan. Pull correctly rated high voltage and low voltage through appropriate conduits. Connect the power conduit to the internal disconnect (if unit is so equipped) or to the external disconnect (through unit side panel). A hole must be field cut in the main control box bottom on the left side so the 24-v control connections can be made. Connect the control power conduit to the unit control box at this hole.

**Units without Thru-Base Connections —**

1. Install power wiring conduit through side panel openings. Install conduit between disconnect and control box.
2. Install power lines to terminal connections as shown in Fig. 19.

Voltage to compressor terminals during operation must be within voltage range indicated on unit nameplate. See Table 3. On 3-phase units, voltages between phases must be balanced within 2% and the current within 10%. Use the formula shown in the legend for Table 3, Note 2 to determine the percent of voltage imbalance. Operation on improper line voltage or excessive phase imbalance constitutes abuse and may cause damage to electrical components. Such operation would invalidate any applicable Carrier warranty.

**Field Control Wiring —**

The 50HT unit requires an external temperature control device. This device can be a thermostat (field-supplied) or a PremierLink controller (available as factory-installed option or as field-installed accessory, for use on a Carrier



Comfort Network or as a stand alone control) or the RTU-MP Controller for Building Management Systems using non-CCN protocols (RTU-MP is available as a factory-installed option only).

### Thermostat —

Install a Carrier-approved accessory thermostat according to installation instructions included with the accessory. For complete economizer function, select a two-stage cooling thermostat. Locate the thermostat accessory on a solid wall in the conditioned space to sense average temperature in accordance with the thermostat installation instructions.

If the thermostat contains a logic circuit requiring 24-v power, use a thermostat cable or equivalent single leads of different colors with minimum of seven leads. If the thermostat does not require a 24-v source (no “C” connection required), use a thermostat cable or equivalent with minimum of six leads. Check the thermostat installation instructions for additional features which might require additional conductors in the cable.

Using unit-mounted convenience outlets: Units with unit-mounted convenience outlet circuits will often require that two disconnects be opened to de-energize all power to the unit. Treat all units as electrically energized until the convenience outlet power is also checked and de-energization is confirmed. Observe National Electrical Code Article 210, Branch Circuits, for use of convenience outlets.

For wire runs up to 50 ft. (15 m), use no. 18 AWG (American Wire Gage) insulated wire [35°C (95°F) minimum]. For 50 to 75 ft. (15 to 23 m), use no. 16 AWG insulated wire [35°C (95°F) minimum]. For over 75 ft. (23 m), use no. 14 AWG insulated wire [35°C (95°F) minimum]. All wire sizes larger than no. 18 AWG cannot be directly connected to the thermostat and will require a junction box and splice at the thermostat.

### Unit without thru-base connection kit —

Pass the thermostat control wires through the hole provided in the corner post; then feed the wires through the conduit built into the raceway of the corner post to the control box. Pull the wires over to the terminal strip on the upper-left corner of the Controls Connection Board. See Fig. 27.

**NOTE:** If thru-the-bottom connections accessory is used, refer to the accessory installation instructions for information on routing power and control wiring.

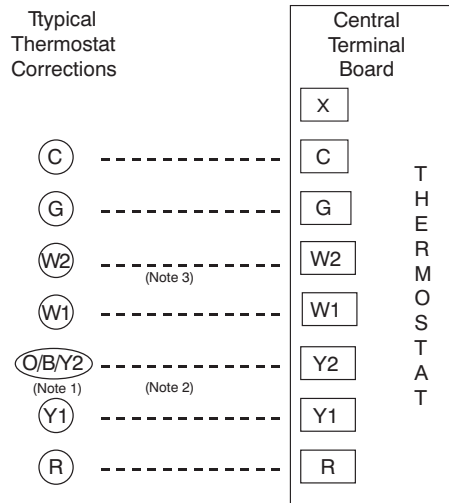

- Note 1: Typical multi-function marking. Follow manufacturer's configuration instructions to select Y2.
  - Note 2: Y2 to Y2 connection required on single-stage cooling units when integrated economizer function is desired
  - Note 3: W2 connection not required on units with single-stage heating.
- Field Wiring

C08575

**Fig. 26 - Low-Voltage Connections**

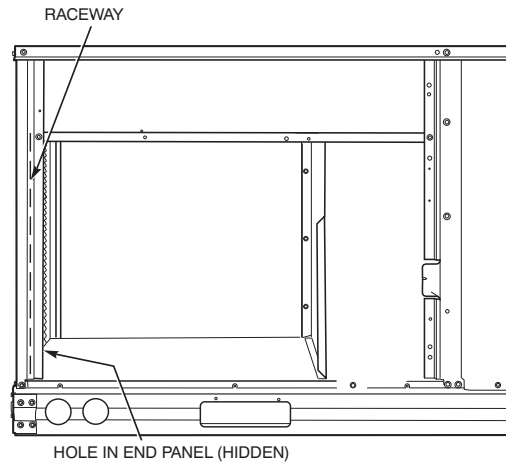

C08027

**Fig. 27 - Field Control Wiring Raceway**

**NOTE:** If thru-the-bottom connections accessory is used, refer to the accessory installation instructions for information on routing power and control wiring.

### Heat Anticipator Settings —

Set heat anticipator settings at 0.14 amp for the first stage and 0.14 amp for second-stage heating, when available.

### Electric Heaters

50HT units may be equipped with field-installed accessory electric heaters. The heaters are modular in design, with heater frames holding open coil resistance wires strung through ceramic insulators, line-break limit switches and a control contactor. One or two heater modules may be used in a unit.

Heater modules are installed in the compartment below the indoor (supply) fan outlet. Access is through the indoor access panel. Heater modules slide into the

50HT

compartment on tracks along the bottom of the heater opening. See Fig. 28, Fig. 29 and Fig. 30.

Not all available heater modules may be used in every unit. Use only those heater modules that are UL listed for use in a specific size unit. Refer to the label on the unit cabinet for the list of approved heaters.

Unit heaters are marked with Heater Model Numbers. But heaters are ordered as and shipped in cartons marked with a corresponding heater Sales Package part number. See Table 2 for correlation between heater Model Number and Sales Package part number.

**NOTE:** The value in position 9 of the part number differs between the sales package part number (value is 1) and a bare heater model number (value is 0).

50HT

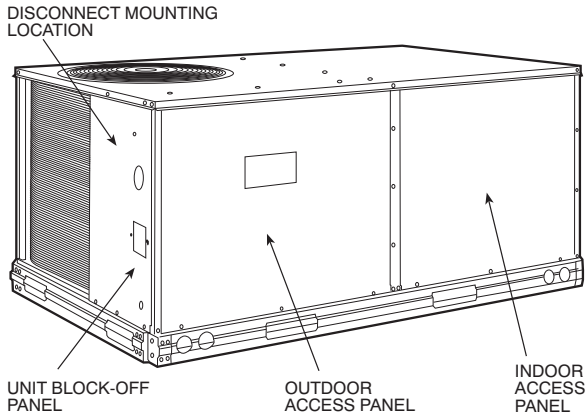

**Fig. 28 - Typical Access Panel Location (3-6 Ton)**

C08133

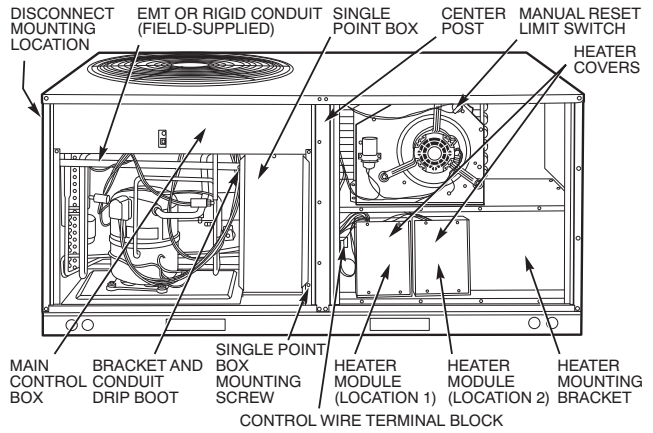

**Fig. 29 - Typical Component Location**

C08134

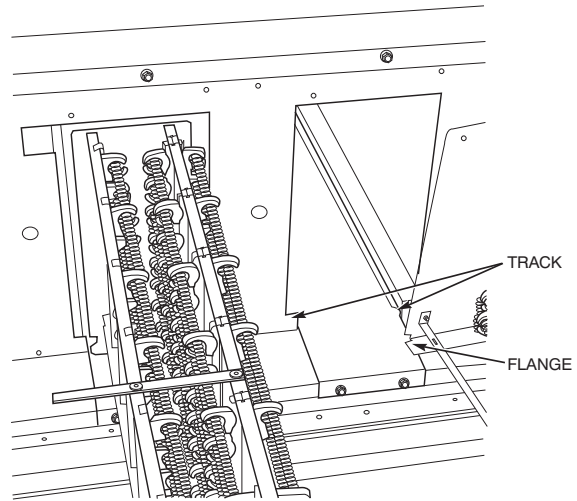

**Fig. 30 - Typical Module Installation**

C08135

**Table 2 – Heater Model Number**

<b>Bare Heater Model Number</b>	C	R	H	E	A	T	E	R	0	0	1	A	0	0
<b>Heater Sales Package PNO Includes:</b> Bare Heater Carton and packing materials Installation sheet	C	R	H	E	A	T	E	R	1	0	1	A	0	0

**Single Point Boxes and Supplementary Fuses** — When the unit MOCB device value exceeds 60-A, unit-mounted supplementary fuses are required for each heater circuit. These fuses are included in accessory Single Point Boxes, with power distribution and fuse blocks. The single point box will be installed directly under the unit control box, just to the left of the partition separating the indoor section (with electric heaters) from the outdoor section. The Single Point Box has a hinged access cover. See Fig. 31. The Single Point Box also includes a set of power taps and pigtailed to complete the wiring between the Single Point Box and the unit's main control box terminals. Refer to the accessory heater and Single Point Box installation instructions for details on tap connections.

All fuses on 50HT units are 60-A. (Note that all heaters are qualified for use with a 60-A fuse, regardless of actual heater ampacity, so only 60-A fuses are necessary.)

**Single Point Boxes without Fuses** — Unit heater applications not requiring supplemental fuses require a special Single Point Box without any fuses. The accessory Single Point Boxes contain a set of power taps and pigtailed to complete the wiring between the Single Point Box and the unit's main control box terminals. Refer to accessory heater and Single Point Box installation instructions for details on tap connections.

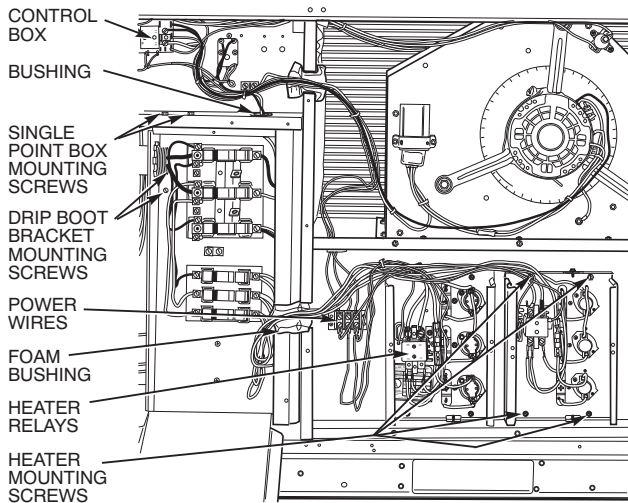

C08136

**Fig. 31 - Typical Single Point Installation**

**Low-Voltage Control Connections** — Pull the low-voltage control leads from the heater module(s) - VIO and BRN (two of each if two modules are installed; identify for Module #1) - to the 4-pole terminal board TB4 located on the heater bulkhead to the left of Heater #1. Connect the VIO lead from Heater #1 to terminal TB4-1. For 2 stage heating, connect the VIO lead from Heater #2 to terminal TB4-2. For 1 stage heating with 2 heater modules connect the VIO lead from both Heater #1 and #2 to terminal TB4-1. Connect both BRN leads to terminal TB4-3. See Fig. 32.

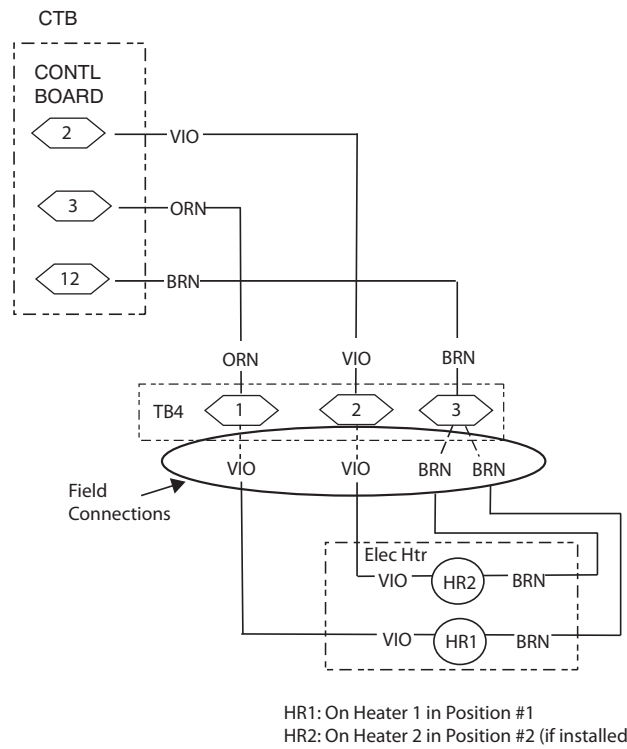

C08331

**Fig. 32 - Accessory Electric Heater Control Connections**

**Smoke Detectors** —

Smoke detectors are available as factory-installed options on 50HT models. Smoke detectors may be specified for Supply Air only or for Return Air without or with economizer or in combination of Supply Air and Return Air. Return Air smoke detectors are arranged for vertical return configurations only. All components necessary for operation are factory-provided and mounted. The unit is factory-configured for immediate smoke detector shutdown operation; additional wiring or modifications to unit terminal board may be necessary to complete the unit and smoke detector configuration to meet project requirements.

Units equipped with factory-optional Return Air smoke detectors require a relocation of the sensor module at unit installation. See “**Completing Installation of Return Air Smoke Sensor:**” for details.

**System**

The smoke detector system consists of a four-wire controller and one or two sensors. Its primary function is to shut down the rooftop unit in order to prevent smoke from circulating throughout the building. It is not to be used as a life saving device.

**Controller**

The controller (see Fig. 33) includes a controller housing, a printed circuit board, and a clear plastic cover. The controller can be connected to one or two compatible duct smoke sensors. The clear plastic cover is secured to the housing with a single captive screw for easy access to the wiring terminals. The controller has three LEDs (for Power, Trouble and Alarm) and a manual test/reset button (on the cover face).

50HT

## Sensor

The sensor (see Fig. 34) includes a plastic housing, a printed circuit board, a clear plastic cover, a sampling tube inlet and an exhaust tube. The sampling tube (when used) and exhaust tube are attached during installation. The sampling tube varies in length depending on the size of the rooftop unit. The clear plastic cover permits visual inspections without having to disassemble the sensor. The cover attaches to the sensor housing using four captive screws and forms an airtight chamber around the sensing electronics. Each sensor includes a harness with an RJ45 terminal for connecting to the controller. Each sensor has four LEDs (for Power, Trouble, Alarm and Dirty) and a manual test/reset button (on the left-side of the housing).

Air is introduced to the duct smoke detector sensor's sensing chamber through a sampling tube that extends into the HVAC duct and is directed back into the ventilation system through a (shorter) exhaust tube. The difference in air pressure between the two tubes pulls the sampled air through the sensing chamber. When a sufficient amount of smoke is detected in the sensing chamber, the sensor signals an alarm state and the controller automatically takes the appropriate action to shut down fans and blowers, change over air handling systems, notify the fire alarm control panel, etc.

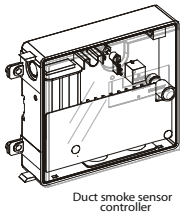

Duct smoke sensor controller

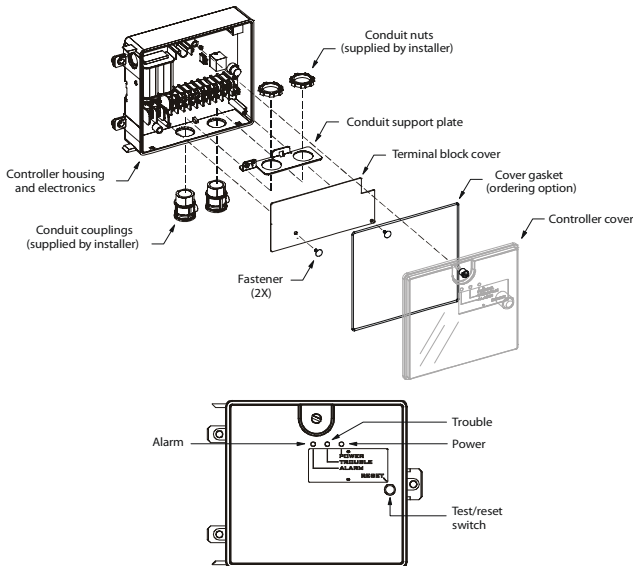
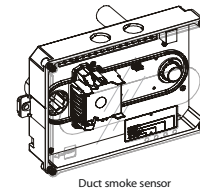

Fig. 33 - Controller Assembly

C08208



Duct smoke sensor

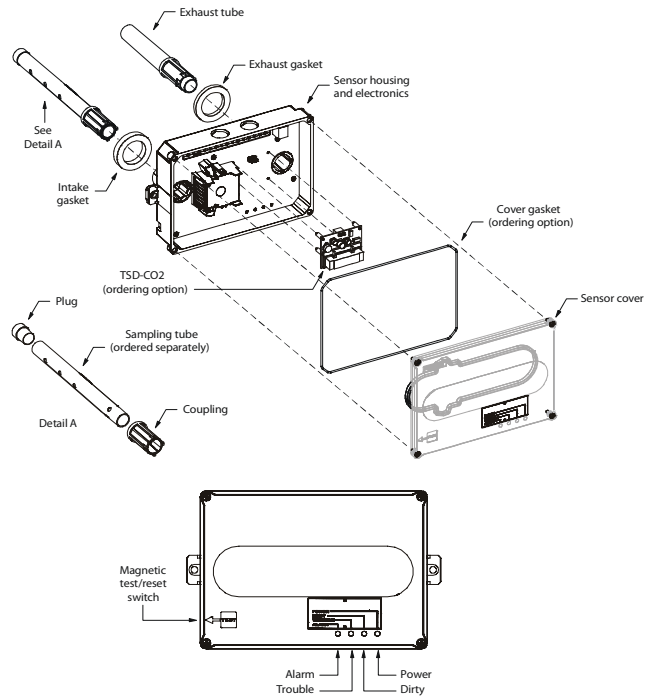

Fig. 34 - Smoke Detector Sensor

C08209

The sensor uses a process called differential sensing to prevent gradual environmental changes from triggering false alarms. A rapid change in environmental conditions, such as smoke from a fire, causes the sensor to signal an alarm state but dust and debris accumulated over time does not.

For installations using two sensors, the duct smoke detector does not differentiate which sensor signals an alarm or trouble condition.

### Smoke Detector Locations

**Supply Air** — The Supply Air smoke detector sensor is located to the left of the unit's indoor (supply) fan. See Fig. 35. Access is through the fan access panel. There is no sampling tube used at this location. The sampling tube inlet extends through the side plate of the fan housing (into a high pressure area). The controller is located on a bracket to the right of the return filter, accessed through the lift-off filter panel.

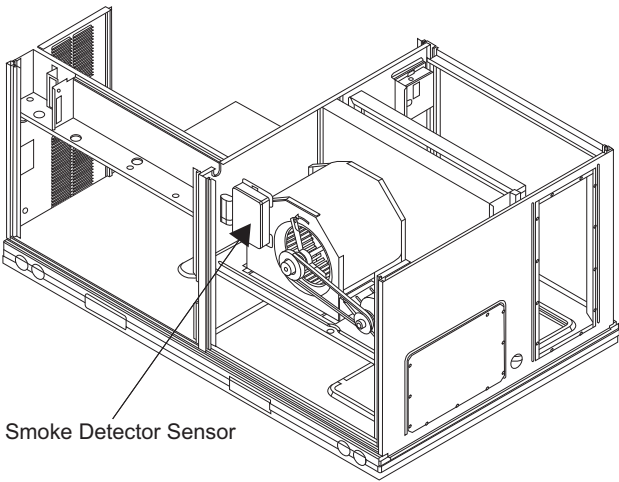

C08245

**Fig. 35 - Typical Supply Air Smoke Detector Sensor Location**

Return Air without Economizer — The sampling tube is located across the return air opening on the unit basepan. See Fig. 36. The holes in the sampling tube face downward, into the return air stream. The sampling tube is connected via tubing to the return air sensor that is mounted on a bracket high on the partition between return filter and controller location. (This sensor is shipped in a flat-mounting location. Installation requires that this sensor be relocated to its operating location and the tubing to the sampling tube be connected. See “**Completing Installation of Return Air Smoke Sensor:**” for details.)

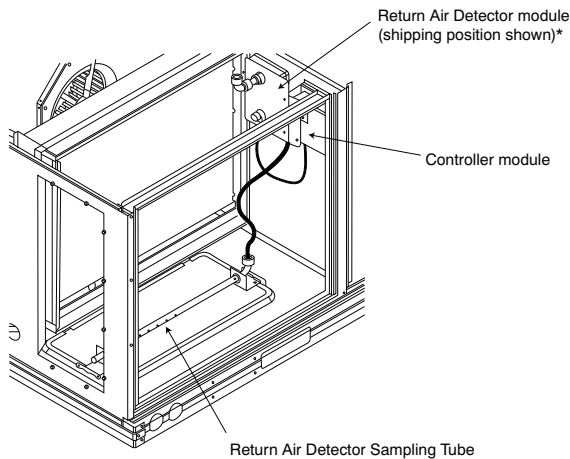

\*RA detector must be moved from shipping position to operating position by installer

C07307

**Fig. 36 - Typical Return Air Detector Location**

Return Air with Economizer — The sampling tube is inserted through the side plates of the economizer housing, placing it across the return air opening on the unit basepan. See Fig. 37. The holes in the sampling tube face downward, into the return air stream. The sampling tube is connected via tubing to the return air sensor that is mounted on a bracket high on the partition between return filter and controller location. (This sensor is shipped in a flat-mounting location. Installation requires that this sensor be relocated to its operating location and the tubing to the sampling tube be connected. See the following installation procedure.)

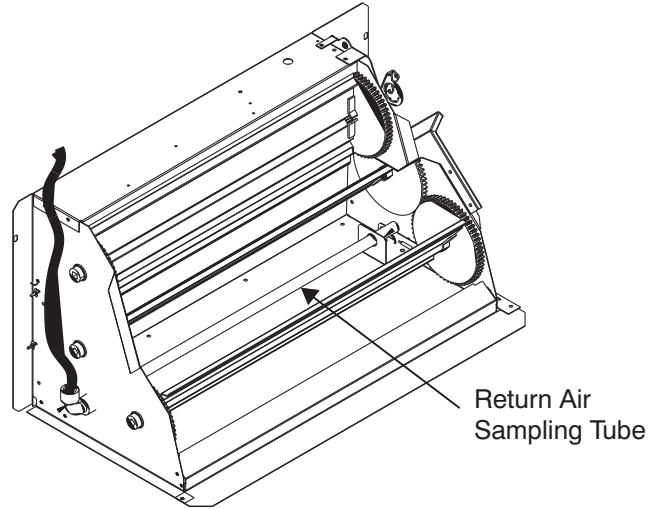

C08129

**Fig. 37 - Return Air Sampling Tube Location**

### Completing Installation of Return Air Smoke Sensor:

1. Unscrew the two screws holding the Return Air Sensor detector plate. See Fig. 39. Save the screws.
2. Remove the Return Air Sensor and its detector plate.
3. Rotate the detector plate so the sensor is facing outwards and the sampling tube connection is on the bottom. See Fig. 40 and Fig. 38.
4. Screw the sensor and detector plate into its operating position using screws from Step 1. Make sure the sampling tube connection is on the bottom and the exhaust tube is on the top. See Fig. 40.

50HT

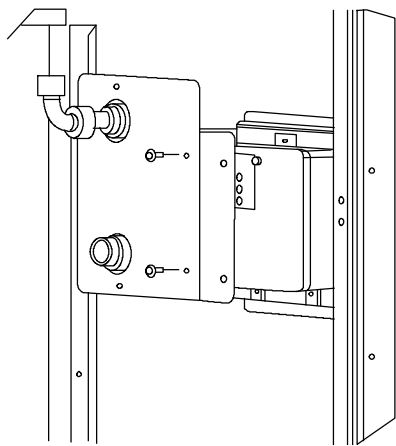

As received in the field. The modules are side by side.

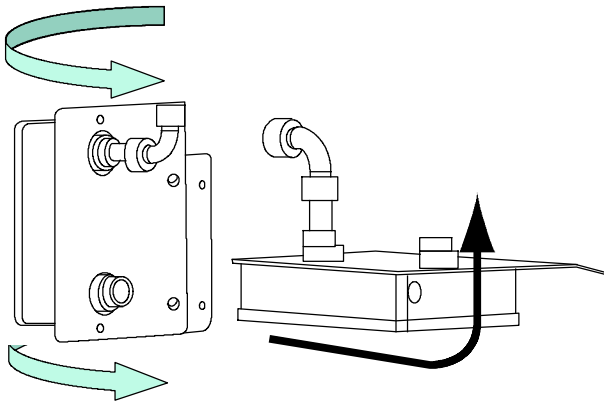

Unfasten the module containing the elbow fitting. Turn it 90° and rotate end to end to where fitting is pointing down. Notice the mounting bracket has a slight bend to it.

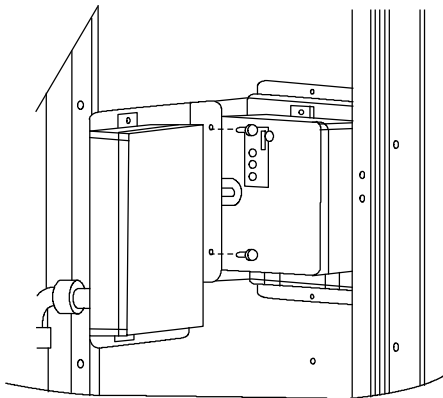

Attach the mounting bracket to the sensor module as shown.

Fig. 38 - Reposition Return Air Smoke

C10319

5. Connect the flexible tube on the sampling inlet to the sampling tube on the basepan.

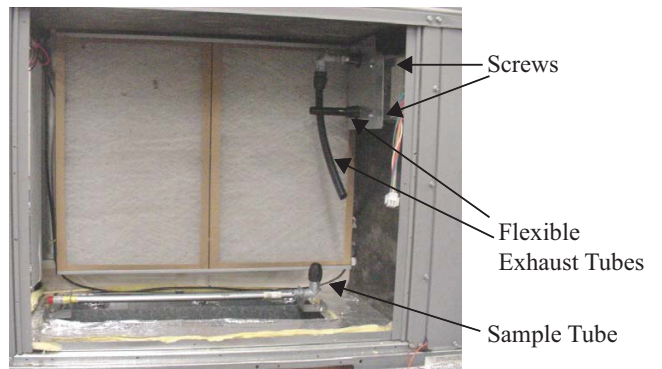

C08126

Fig. 39 - Return Air Detector Shipping Position



C08127

Fig. 40 - Return Air Sensor Operating Position

Additional Application Data — Refer to Catalog No. HKRNKA-1XA for discussions on additional control features of these smoke detectors including multiple unit coordination.

**Table 3 – Table 10 Unit Electrical Data (cont)**

UNIT	NOM. V – PH – HZ	IFM TYPE	ELECTRIC HEATER PART NUMBER CRHEATERXXXXXX	NOM (kW)	APPLICATION (kW)	SINGLE POINT OR JUNCTION KIT PART NUMBER CRSINGLE***A00			
						NO C.O. or UNPWRD C.O.		w/PWRD C.O.	
						NO PE.	w/ P.E. (pwrd fr/unit)	NO PE.	w/ P.E. (pwrd fr/unit)
50HT**07	208/230 – 3 – 60	STD	102A00	6.5	4.9/6.0	–	–	–	–
			104B00	10.5	7.9/9.6	–	–	–	–
			105A00	16.0	12.0/14.7	–	–	038	038
			104B00,104B00	21.0	15.8/19.3	038	038	038	038
			104B00,105A00	26.5	19.9/24.3	038	038	038	038
		102A00	6.5	4.9/6.0	–	–	–	–	
	104B00	10.5	7.9/9.6	–	–	–	–		
	105A00	16.0	12.0/14.7	–	–	038	038		
	104B00,104B00	21.0	15.8/19.3	038	038	038	038		
	104B00,105A00	26.5	19.9/24.3	038	038	038	038		
	HIGH	102A00	6.5	4.9/6.0	–	–	–	–	
		104B00	10.5	7.9/9.6	–	–	–	–	
		105A00	16.0	12.0/14.7	–	–	038	038	
		104B00,104B00	21.0	15.8/19.3	038	038	038	038	
		104B00,105A00	26.5	19.9/24.3	038	038	038	038	
	460 – 3 – 60	STD	106A00	6.0	5.5	–	–	–	–
			108A00	11.5	10.6	–	–	–	–
			109A00	14.0	12.9	–	–	–	–
108A00,108A00			23.0	21.1	–	–	–	–	
108A00,109A00			25.5	23.4	–	–	–	–	
MED		106A00	6.0	5.5	–	–	–	–	
		108A00	11.5	10.6	–	–	–	–	
		109A00	14.0	12.9	–	–	–	–	
		108A00,108A00	23.0	21.1	–	–	–	–	
		108A00,109A00	25.5	23.4	–	–	–	–	
HIGH		106A00	6.0	5.5	–	–	–	–	
		108A00	11.5	10.6	–	–	–	–	
	109A00	14.0	12.9	–	–	–	–		
			108A00,108A00	23.0	21.1	–	–	–	–
			108A00,109A00	25.5	23.4	–	–	–	–

50HT

**LEGEND:**

- CO – Convenient outlet
- DISC – Disconnect
- FLA – Full load amps
- IFM – Indoor fan motor
- LRA – Locked rotor amps
- MCA – Minimum circuit amps
- MOCPP – Maximum over current protection
- PE – Power exhaust
- UNPWRD CO – Unpowered convenient outlet



Example: Supply voltage is 230-3-60



- AB = 224 v
- BC = 231 v
- AC = 226 v

$$\text{Average Voltage} = \frac{(224 + 231 + 226)}{3} = \frac{681}{3} = 227$$

Determine maximum deviation from average voltage.

- (AB) 227 – 224 = 3 v . . . . . Maximum deviation is 4 v.
- (BC) 231 – 227 = 4 v . . . . . Determine percent of voltage imbalance.

$$\% \text{ Voltage Imbalance} = 100 \times \frac{4}{227} = 1.76\%$$

This amount of phase imbalance is satisfactory as it is below the maximum allowable 2%.

**IMPORTANT:** If the supply voltage phase imbalance is more than 2%, contact your local electric utility company immediately.

$$\% \text{ Voltage Imbalance} = 100 \times \frac{\text{max voltage deviation from average voltage}}{\text{average voltage}}$$

