

**50LC**

**WeatherExpert® Series**

**Single Package Rooftop**

**Cooling Only**

**with Puron® (R-410A) Refrigerant**

**Sizes: 14, 17, 20, 24, 26**



# Installation Instructions

**NOTE:** Read the entire instruction manual before starting the installation.

## TABLE OF CONTENTS

SAFETY CONSIDERATIONS .....	2
Rated Indoor Airflow (CFM) .....	3
INSTALLATION .....	13
Jobsite Survey .....	13
Step 1 - Plan for Unit Location .....	13
Roof Mount .....	14
Step 2 - Plan for Sequence of Unit Installation .....	14
Curb-Mounted Installation .....	14
Pad-Mounted Installation .....	14
Frame-Mounted Installation .....	14
Step 3 - Inspect Unit .....	14
Step 4 - Provide Unit Support .....	14
Roof Curb Mount .....	14
Slab Mount (Horizontal Units Only) .....	18
Alternate Unit Support (In Lieu of Curb or Slab Mount) .....	18
Step 5 - Field Fabricate Ductwork .....	18
Step 6 - Rig and Place Unit .....	18
Positioning on Curb .....	18
Step 7 - Horizontal Duct Connection .....	19
Step 8 - Install Outside Air Hood — Factory Option ..	20
Step 9 - Install External Condensate Trap and Line ...	21
Step 10 - Make Electrical Connections .....	21
Field Power Supply .....	21
Units without Factory-Installed Non-Fused Disconnect or HACR .....	29
Units with Factory-Installed Non-Fused Disconnect or HACR .....	29
All Units .....	30
Convenience Outlets .....	30
HACR .....	32
Factory-Option Thru-Base Connections .....	32
Units without Thru-Base Connections .....	32
Field Control Wiring .....	32

Thermostat .....	32
Unit without Thru-Base Conversion Kit .....	33
Heat Anticipator Settings .....	33
Transformer Connection for 208-v Power Supply .....	33
Electric Heaters .....	34
Low-Voltage Control Connections .....	34
Humidi-MiZer® System Control Connections ....	35
Humidi-MiZer System - Space RH Controller ..	35
RTU Open Controller (Factory-Installed Option) ..	35
SystemVu™ Controller (Factory-Installed Option)	35
Integrated Staging Control (ISC) Board .....	36
ISC Board — Sequence of Operation .....	36
General .....	36
Ventilation .....	36
Cooling .....	37
Humidi-MiZer System (Optional) .....	37
Economizer (Optional) .....	37
Low Ambient Cooling Operation Down to 40°F (4°C) .....	38
Heating .....	38
EconoMi\$er® X (Factory-Installed Option) .....	38
Unit Installation .....	38
Enthalpy Sensor Relocation .....	38
W7220 Economizer Controller .....	38
User Interface .....	39
Keypad .....	39
Menu Structure .....	39
Connections and Applications .....	44
W7220 Economizer Module Wiring .....	44
Economizer Control Configurations .....	45
Enthalpy Changeover Control .....	45
Enthalpy Settings .....	45
Demand Controlled Ventilation .....	47
Economizer Occupancy Control .....	48
Hardware .....	49
Actuators .....	49

Supply Air Temperature Sensor .....	49
Outside Air Temperature Sensor .....	49
Enthalpy Control Sensor Configuration .....	49
Operating Sequences .....	50
Staged Air Volume (3-Speed) Fan Motor .....	50
W7220 Economizer Control .....	50
Base Unit Controls .....	50
Cooling, Unit with EconoMiSer® X without CO <sub>2</sub> Sensor .....	50
Heating with EconoMiSer X .....	52
Demand Controlled Ventilation .....	53
Setup and Configuration .....	53
Initial Menu Display .....	53
Time-out and Screensaver .....	53
Checkout .....	53
Status .....	54
Calibration of Sensors .....	54
Resetting All Defaults .....	54
Troubleshooting .....	54
Power Up Delay .....	54
Power Loss (Outage or Brownout) .....	54
Alarms .....	54
Clearing Alarms .....	54
Control Set Point and Configuration Log .....	57
Staged Air Volume (SAV™) with Variable Frequency Drive .....	60
Multi-Speed VFD Display Kit (Field-Installed Accessory) .....	61
Connecting the Keypad to the VFD .....	61
Program the VFD for 3 Discrete Indoor Fan Speeds .....	62
Smoke Detectors .....	92
Return Air Sensor Tube Installation .....	92
Smoke Detector Test Magnet .....	93
Additional Application Data .....	93
Step 11 - Install Accessories .....	93
Step 12 - Check Belt Tension .....	93
UNIT START-UP CHECKLIST .....	95

## SAFETY CONSIDERATIONS

Improper installation, adjustment, alteration, service, maintenance, or use can cause explosion, fire, electrical shock or other conditions which may cause personal injury or property damage. Consult a qualified installer, service agency, or your distributor or branch for information or assistance. The qualified installer or agency must use factory-authorized kits or accessories when modifying this product. Refer to the individual instructions packaged with the kits or accessories when installing.

Follow all safety codes. Wear safety glasses and work gloves. Use quenching cloths for brazing operations and have a fire extinguisher available. Read these instructions thoroughly and follow all warnings or cautions attached to the unit. Consult local building codes and appropriate national electrical codes (in USA, ANSI/NFPA 70, National Electrical Code (NEC); in Canada, CSA C22.1) for special requirements.

It is important to recognize safety information. This is the safety-alert symbol . When you see this symbol on the unit and in instructions or manuals, be alert to the potential for personal injury.

Understand the signal words DANGER, WARNING, CAUTION, and NOTE. These words are used with the safety-alert symbol. DANGER identifies the most serious hazards which **will** result in severe personal injury or death. WARNING signifies hazards which **could** result in personal injury or death. CAUTION is used to identify unsafe practices, which **may** result in minor personal injury or product and property damage. NOTE is used to highlight suggestions which **will** result in enhanced installation, reliability, or operation.

### WARNING

#### ELECTRICAL SHOCK HAZARD

Failure to follow this warning could cause personal injury or death.

Before performing service or maintenance operations on unit, always turn off main power switch to unit and install lock(s) and lockout tag(s). Unit may have more than one power switch.

### WARNING

#### UNIT OPERATION AND SAFETY HAZARD

Failure to follow this warning could cause personal injury, death and/or equipment damage.

Puron® (R-410A) refrigerant systems operate at higher pressures than standard R-22 systems. Do not use R-22 service equipment or components on Puron refrigerant equipment.

### WARNING

#### PERSONAL INJURY AND ENVIRONMENTAL HAZARD

Failure to follow this warning could cause personal injury or death.

Relieve pressure and recover all refrigerant before system repair or final unit disposal.

Wear safety glasses and gloves when handling refrigerants. Keep torches and other ignition sources away from refrigerants and oils.

# ⚠ CAUTION

## CUT HAZARD

Failure to follow this caution may result in personal injury.

Sheet metal parts may have sharp edges or burrs. Use care and wear appropriate protective clothing, safety glasses and gloves when handling parts and servicing air conditioning equipment.

## Rated Indoor Airflow (cfm)

This table lists the rated indoor airflow used for the AHRI efficiency rating for the units covered in this document.

Model Number	Full Load Airflow (cfm)
50LC**14	4375
50LC**17	4875
50LC**20	5690
50LC**24	6500
50LC**26	7500

Position:	1	2	3	4	5	6	7	8	9	10	11	12	13	14	15	16	17	18
Example:	5	0	L	C	D	0	2	4	A	1	A	5	-	0	A	0	A	0

### Unit Heat Type

50 - Electric Cooling  
Packaged Rooftop

### Model Series - WeatherExpert®

LC - Ultra High Efficiency

### Heat Options

0 = Standard - No Electric Heat  
D = Low Electric Heat  
E = Medium Electric Heat  
F = High Electric Heat

### Refrig. Systems Options

0 = Three stage cooling capacity control with TXV  
A = Three stage cooling capacity control with TXV and Humidi-MiZer® system

### Cooling Tons

14 - 12.5 ton  
17 - 15 ton  
20 - 17.5 ton  
24 - 20 ton  
26 - 23 ton

### Sensor Options

A = None  
B = RA Smoke Detector  
C = SA Smoke Detector  
D = RA + SA Smoke Detector  
E = CO<sub>2</sub>  
F = RA Smoke Detector and CO<sub>2</sub>  
G = SA Smoke Detector and CO<sub>2</sub>  
H = RA + SA Smoke Detector and CO<sub>2</sub>

### Indoor Fan Motor Options

1 = Standard Static / Vertical Supply, Return Air Flow  
2 = Medium Static / Vertical Supply, Return Air Flow  
3 = High Static / Vertical Supply, Return Air Flow  
4 = Ultra High Static / Vertical Supply, Return Air Flow  
5 = Standard Static / Horizontal Supply, Return Air Flow  
6 = Medium Static / Horizontal Supply, Return Air Flow  
7 = High Static / Horizontal Supply, Return Air Flow  
8 = Ultra High Static / Horizontal Supply, Return Air Flow

### Coil Options: Fin/Tube (Condenser- Evaporator - Hail Guard)

A = Al/Cu - Al/Cu  
B = Precoat Al/Cu - Al/Cu  
C = E-coat Al/Cu - Al/Cu  
D = E-coat Al/Cu - E-coat Al/Cu  
E = Cu/Cu - Al/Cu  
F = Cu/Cu - Cu/Cu  
M = Al/Cu -Al/Cu — Louvered Hail Guard  
N = Precoat Al/Cu - Al/Cu — Louvered Hail Guard  
P = E-coat Al/Cu - Al/Cu — Louvered Hail Guard  
Q = E-coat Al/Cu - E-coat Al/Cu — Louvered Hail Guard  
R = Cu/Cu - Al/Cu — Louvered Hail Guard  
S = Cu/Cu - Cu/Cu — Louvered Hail Guard

### Packaging

0 = Standard  
1 = LTL

### Electrical Options

A = None  
B = HACR Circuit Breaker  
C = Non-Fused Disconnect

### Service Options

0 = None  
1 = Unpowered Convenience Outlet  
2 = Powered Convenience Outlet  
3 = Hinged Panels  
4 = Hinged Panels and Unpowered Convenience Outlet  
5 = Hinged Panels and Powered Convenience Outlet

### Intake / Exhaust Options

A = None  
B = Temperature Standard Leak Economizer with Barometric Relief  
C = Temperature Standard Leak Economizer with Centrifugal Power Exhaust - Vertical Only  
E = Enthalpy Standard Leak Economizer with Barometric Relief  
F = Enthalpy Standard Leak Economizer with Centrifugal Power Exhaust - Vertical Only  
N = Temperature Ultra Low Leak Economizer with Barometric Relief  
P = Temperature Ultra Low Leak Economizer with Centrifugal Power Exhaust - Vertical Only  
R = Enthalpy Ultra Low Leak Economizer with Barometric Relief  
S = Enthalpy Ultra Low Leak Economizer with Centrifugal Power Exhaust - Vertical Only

### Base Unit Controls

0 = Electro-mechanical Controls  
1 = RTU Open Multi-Protocol Controller  
4 = SystemVu™ Controller

### Design Revision

- = Factory Design Revision

### Voltage

1 = 575/3/60  
5 = 208-230/3/60  
6 = 460/3/60

Fig. 1 - 50LC 14-26 Model Number Nomenclature (Example)

UNITED TECHNOLOGIES SPRINGFIELD, CT  
 P. O. BOX 4808  
 SPRINGFIELD, CT 06463  
 13221

THIS DOCUMENT IS THE PROPERTY OF CARRIER CORPORATION AND IS DELIVERED UNDER THE EXPRESS CONDITION THAT THE USER WILL NOT REPRODUCE, COPY, OR TRANSMIT THIS DOCUMENT IN ANY MANNER WITHOUT THE WRITTEN CONSENT OF CARRIER CORPORATION.

HOOD WITH ECONOMIZER OR POWER EXHAUST OPTIONS

CONNECTION SIZES	
A	1 3/8" DIA [35] FIELD POWER SUPPLY KNOCKOUT
B	3" DIA [76] FIELD POWER SUPPLY KNOCKOUT
C	3 5/8" DIA [92] FIELD POWER SUPPLY KNOCKOUT
D	7/8" DIA [22] FIELD CONTROL WIRING HOLE
E	3/4" - 1/4 NPT CONDENSATE DRAIN
G	7/8" DIA [22] FIELD CONTROL WIRING KNOCKOUT

- NOTES:
1. DIMENSIONS ARE IN INCHES. DIMENSIONS IN [ ] ARE IN MILLIMETERS.
  2. CENTER OF GRAVITY
  3. DIRECTION OF AIR FLOW

DEDICATED VERTICAL AIRFLOW UNIT

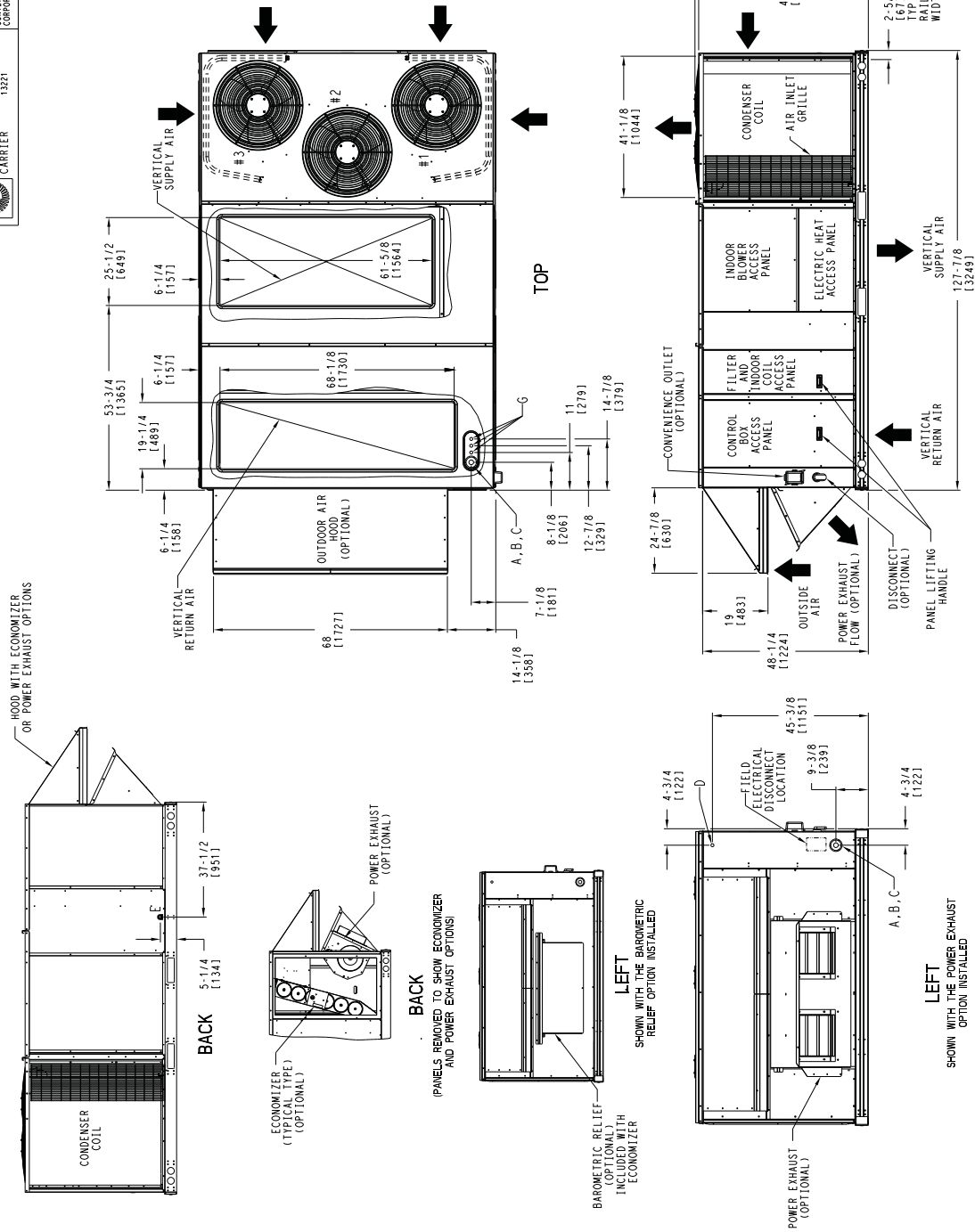

SHEET	DATE	SUPERSEDES	REV
1 OF 3	11/06/12	08/09/12	-

50LC 14 SINGLE ZONE ELECTRICAL COOLING WITH ELECTRIC HEAT

50LC500664

Fig. 2 - Unit Dimensional Drawing - 14 Size Unit

CONNECTION SIZES	
A	1 3/8" DIA (35) FIELD POWER SUPPLY KNOCKOUT
B	3" DIA (76) FIELD POWER SUPPLY KNOCKOUT
C	3 5/8" DIA (92) FIELD POWER SUPPLY KNOCKOUT
D	7/8" DIA (22) FIELD CONTROL WIRING HOLE
E	3/4" - 1/4 NPT CONDENSATE DRAIN
G	7/8" DIA (22) FIELD CONTROL WIRING KNOCKOUT

- NOTES:
1. DIMENSIONS ARE IN INCHES. DIMENSIONS IN ( ) ARE IN MILLIMETERS.
  2. CENTER OF GRAVITY
  3. DIRECTION OF AIR FLOW

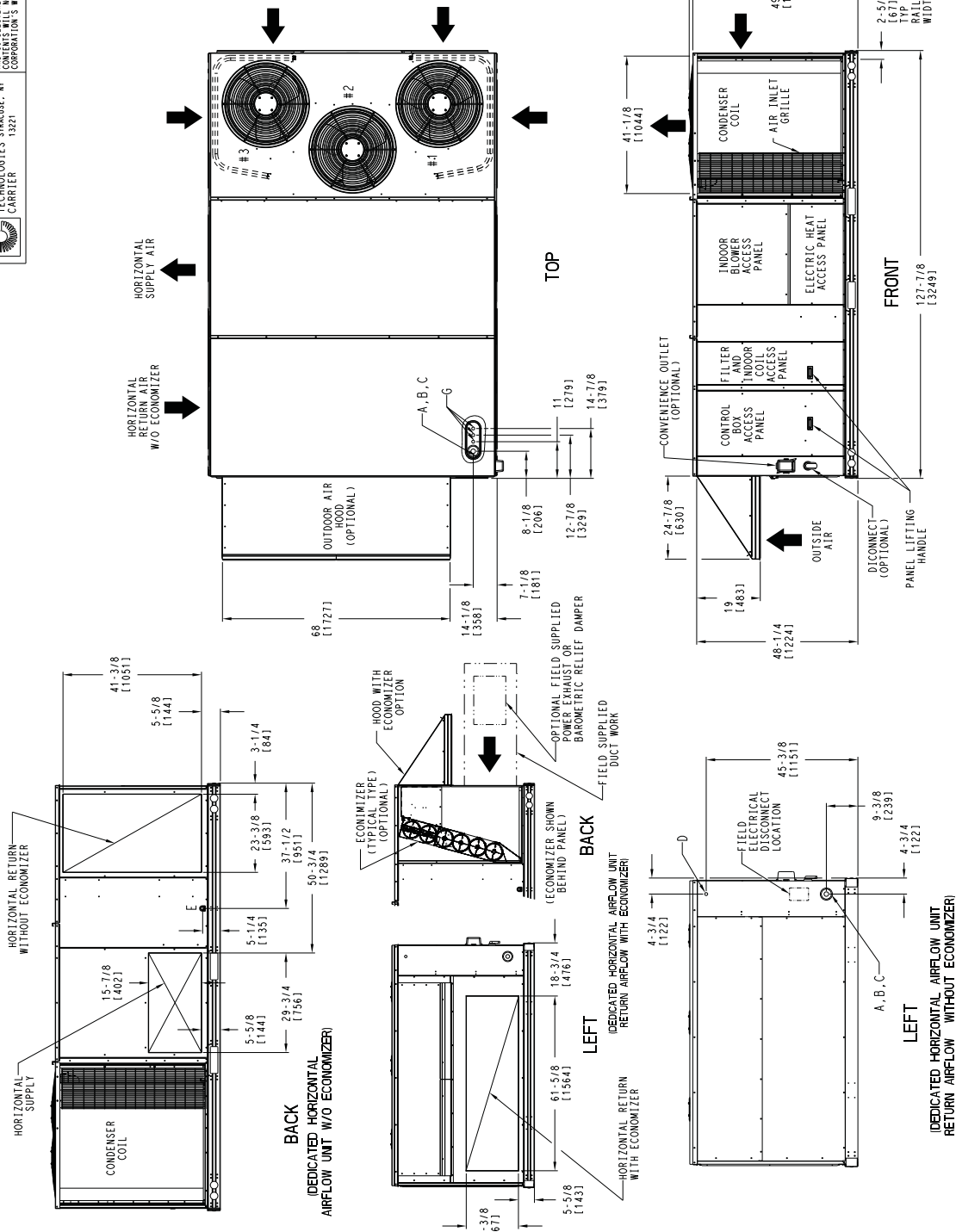

Fig. 2 - Unit Dimensional Drawing – 14 Size Unit (cont)

UNITED TECHNOLOGIES STRAGUERE, NY CORPORATION  
 P.O. BOX 4888  
 13321

THIS DOCUMENT IS THE PROPERTY OF CARRIER CORPORATION. IT IS TO BE USED ONLY FOR THE CARRIER CORPORATION'S WRITTEN CONSENT. SUBMISSION OF THESE DRAWINGS OR DOCUMENTS DOES NOT CONSTITUTE PART PERFORMANCE OR ACCEPTANCE OF CONTRACT.



UNIT	STD. UNIT WEIGHT *		CORNER WEIGHT (A)		CORNER WEIGHT (B)		CORNER WEIGHT (C)		CORNER WEIGHT (D)		C. G.					
	LBS.	KG.	LBS.	KG.	LBS.	KG.	LBS.	KG.	LBS.	KG.	X	Y	Z			
50LC14	1754	797.3	425.8	193.5	495.5	225.3	447.9	203.6	384.9	175.0	40	29/32 [1039.02]	68	21/32 [1743.87]	16	1/2 [419.1]

\* STANDARD UNIT WEIGHT IS WITHOUT ELECTRIC HEAT AND WITHOUT PACKAGING. FOR OTHER OPTIONS AND ACCESSORIES, REFER TO THE PRODUCT DATA CATALOG.

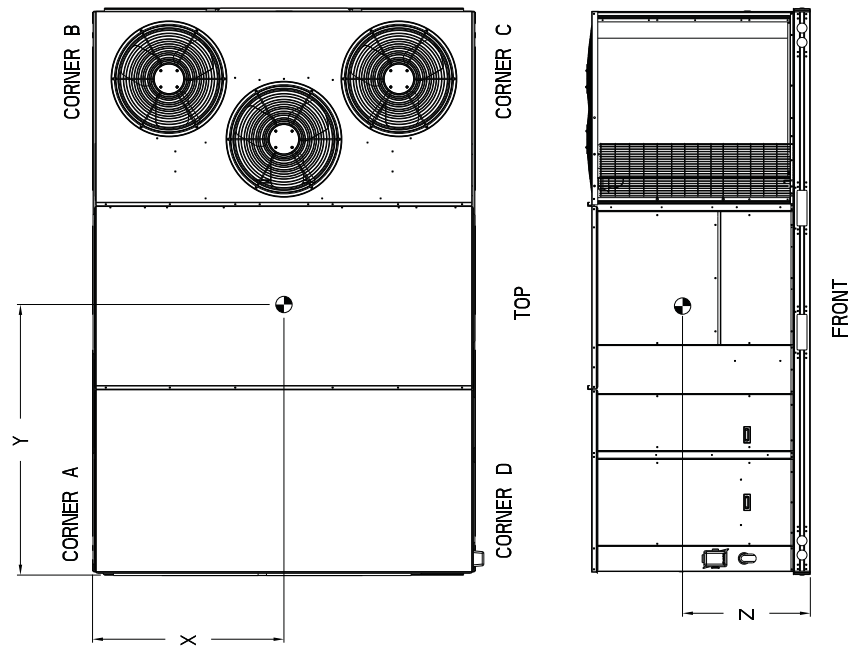

SHEET	DATE	SUPERCEDES	REV
3 OF 3	11/06/12	08/09/12	-
50LC 14 SINGLE ZONE ELECTRICAL COOLING WITH ELECTRIC HEAT			50LC500664

Fig. 2 - Unit Dimensional Drawing – 14 Size Unit (cont)

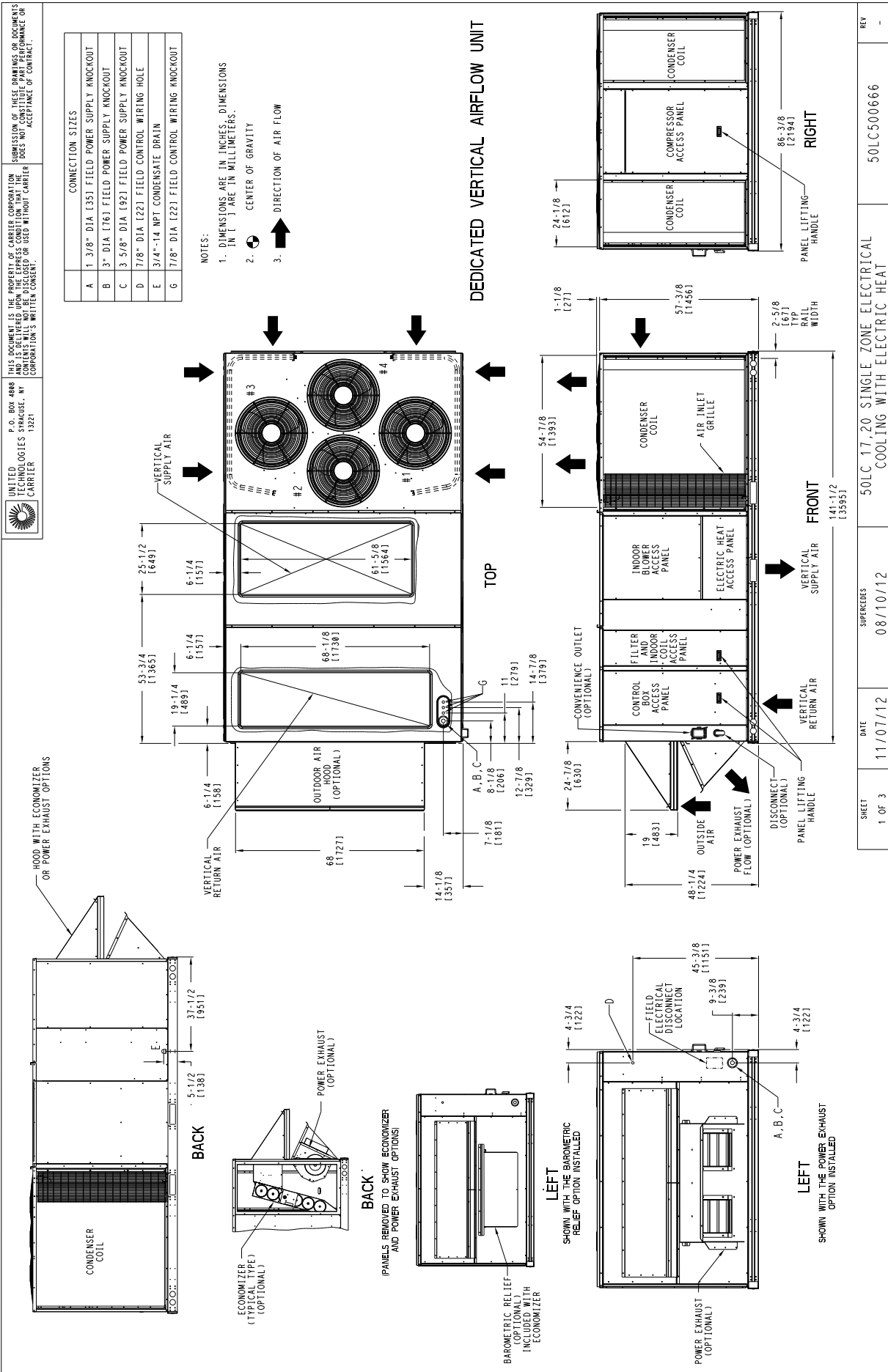

**Fig. 3 - Unit Dimensional Drawing - 17 and 20 Size Units**

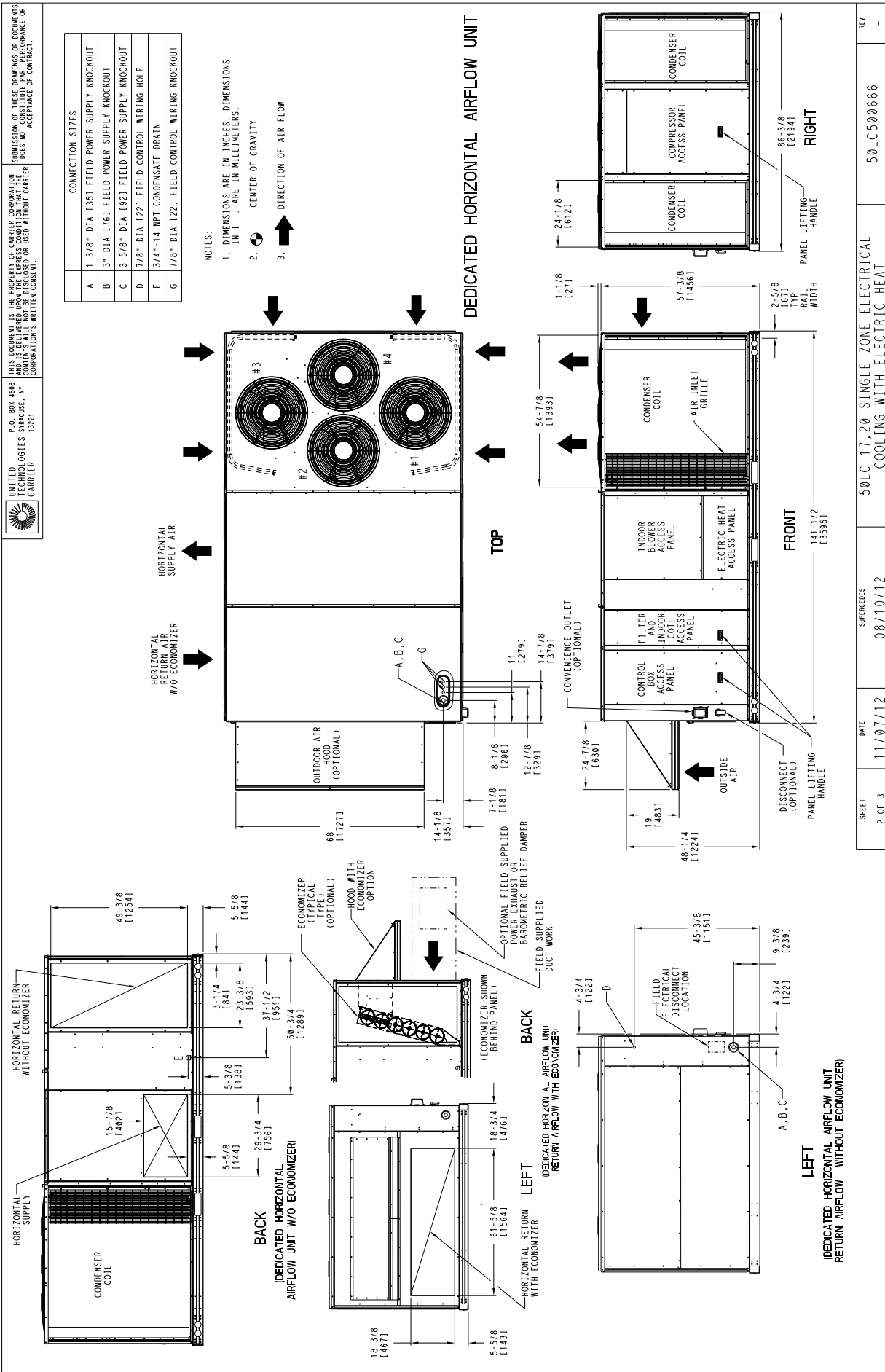

Fig. 3 - Unit Dimensional Drawing - 17 and 20 Size Units (cont)



UNITED TECHNOLOGIES SYRACUSE, NY 13221  
 CARRIER

P.O. BOX 4888  
 THIS DOCUMENT IS THE PROPERTY OF CARRIER CORPORATION AND IS DELIVERED UPON THE EXPRESS CONDITION THAT THE SUBMISSION OF THESE DRAWINGS OR DOCUMENTS DOES NOT CONSTITUTE PART PERFORMANCE OR ACCEPTANCE OF CONTRACT.

UNIT	STD UNIT WEIGHT *		CORNER WEIGHT (A)		CORNER WEIGHT (B)		CORNER WEIGHT (C)		CORNER WEIGHT (D)		C. G.					
	LBS.	KG.	LBS.	KG.	LBS.	KG.	LBS.	KG.	LBS.	KG.	X	Y				
50LC17	1996	907.3	510.2	231.9	487.5	221.6	479.8	218.1	412.2	187.3	38 1/2	[977.90]	76	[1930.40]	19	[482.6]
50LC20	2102	955.7	537.4	244.3	465.6	204.4	505.4	229.7	434.1	197.3	38 1/2	[977.90]	76	[1930.40]	19	[482.6]

\* STANDARD UNIT WEIGHT IS WITHOUT ELECTRIC HEAT AND WITHOUT PACKAGING.  
 FOR OTHER OPTIONS AND ACCESSORIES, REFER TO THE PRODUCT DATA CATALOG.

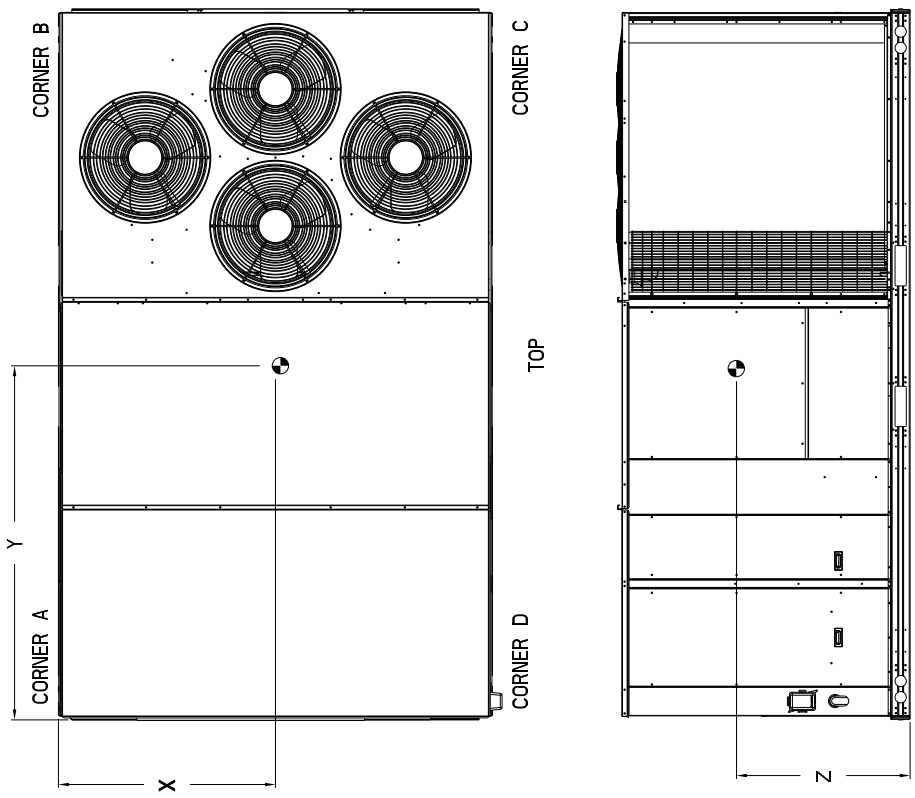

SHEET 3 OF 3	DATE 11/07/12	SUPERSEDES 08/10/12	50LC 17,20 SINGLE ZONE ELECTRICAL COOLING WITH ELECTRIC HEAT	50LC500666	REV -
-----------------	------------------	------------------------	--	------------	----------

Fig. 3 - Unit Dimensional Drawing – 17 and 20 Size Units (cont)

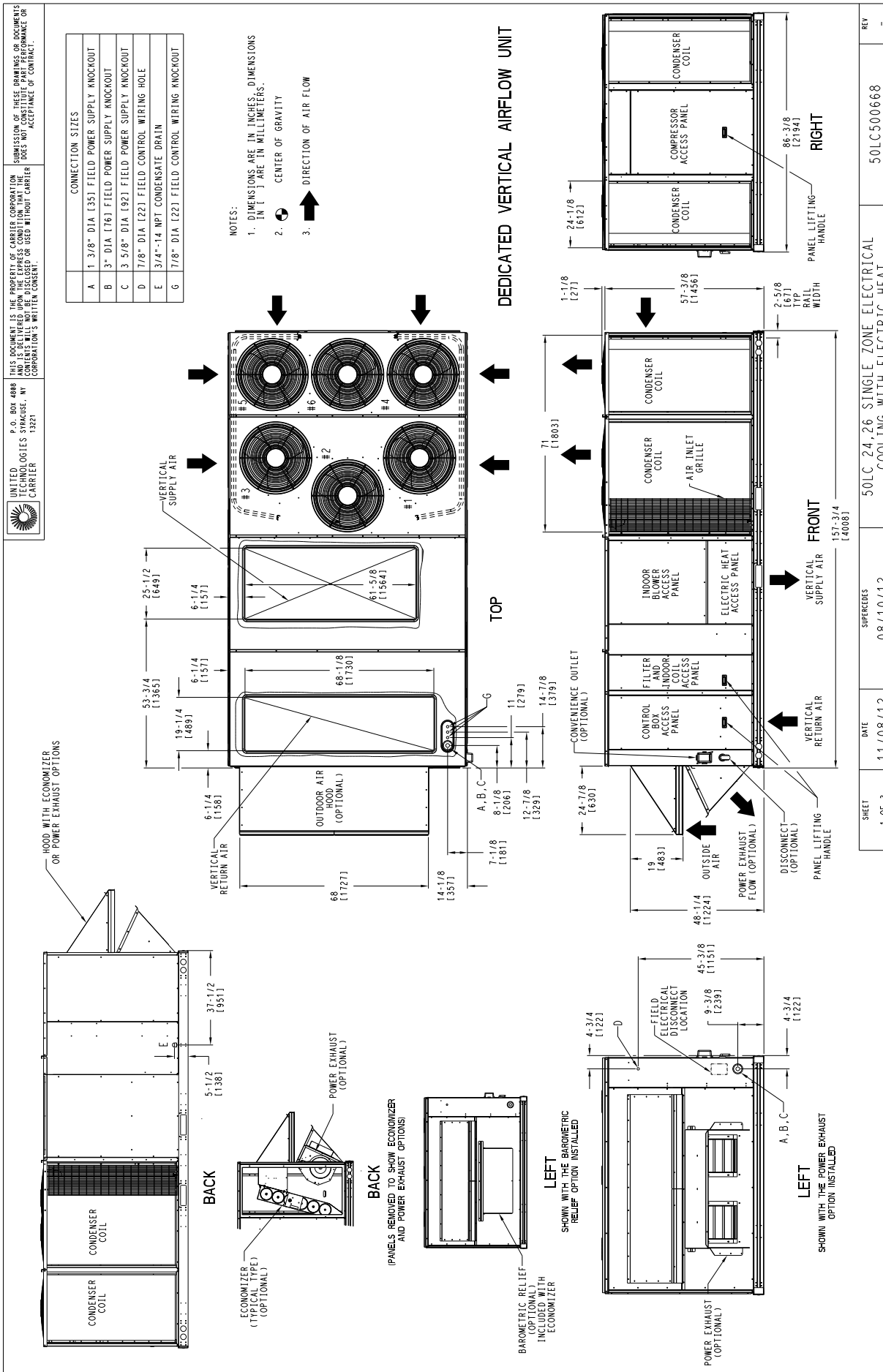
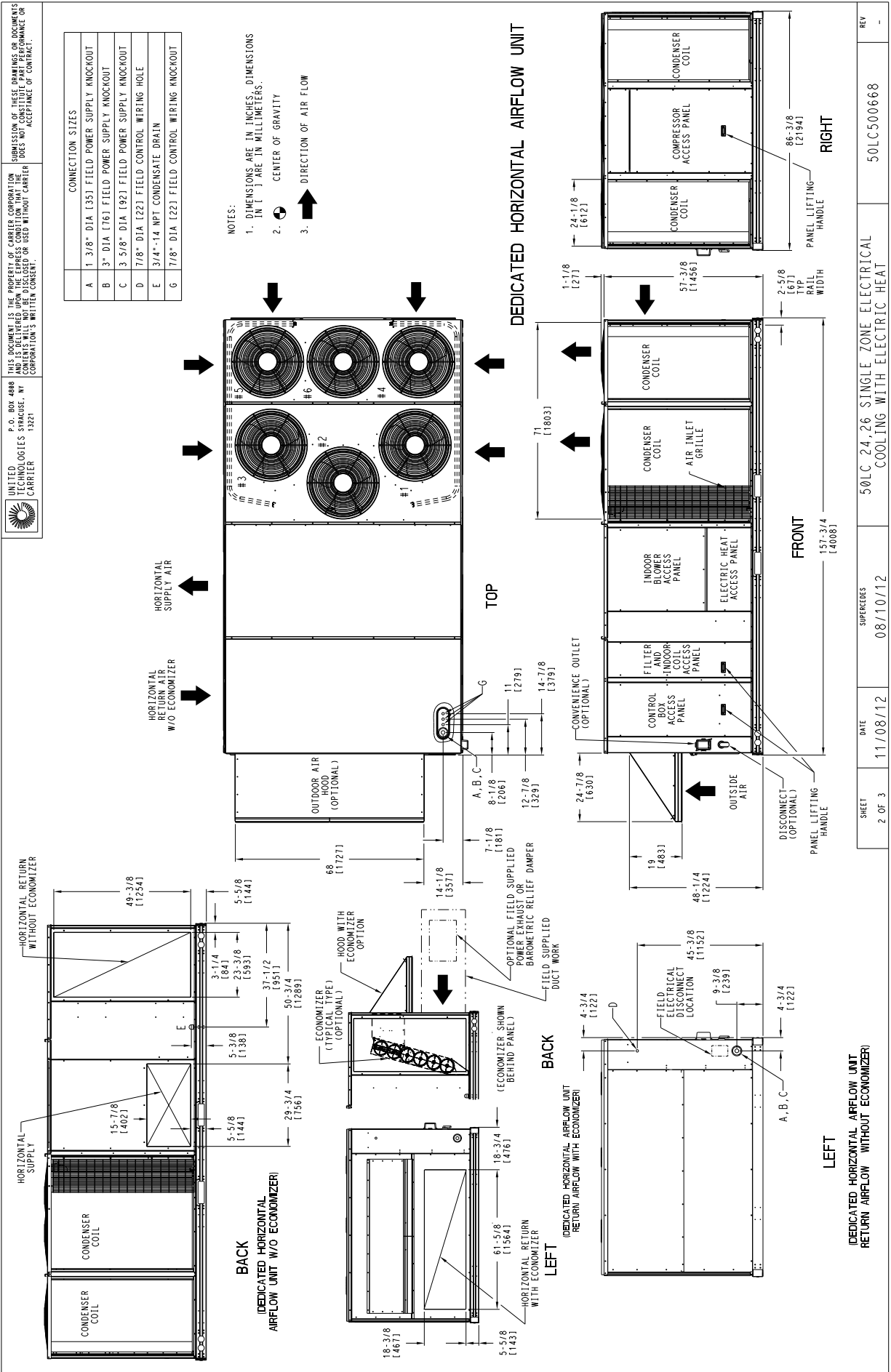

Fig. 4 - Unit Dimensional Drawing – 24 and 26 Size Units



**DEDICATED HORIZONTAL AIRFLOW UNIT**

RETURN AIRFLOW WITH ECONOMIZER

**DEDICATED HORIZONTAL AIRFLOW UNIT**

RETURN AIRFLOW WITHOUT ECONOMIZER

**DEDICATED HORIZONTAL AIRFLOW UNIT**

RETURN AIRFLOW WITH ECONOMIZER

**DEDICATED HORIZONTAL AIRFLOW UNIT**

RETURN AIRFLOW WITHOUT ECONOMIZER

**DEDICATED HORIZONTAL AIRFLOW UNIT**

RETURN AIRFLOW WITH ECONOMIZER

**DEDICATED HORIZONTAL AIRFLOW UNIT**

RETURN AIRFLOW WITHOUT ECONOMIZER

**Fig. 4 - Unit Dimensional Drawing – 24 and 26 Size Units (cont)**

UNITED TECHNOLOGIES STRACOSUE, NY CORPORATION'S WRITTEN CONSENT.  
 P.O. BOX 4088  
 UNITED TECHNOLOGIES STRACOSUE, NY CORPORATION'S WRITTEN CONSENT.  
 THIS DOCUMENT IS THE PROPERTY OF CARRIER CORPORATION AND IS LOANED TO YOU UNDER THE EXPRESS CONDITION THAT IT DOES NOT CONSTITUTE PART PERFORMANCE OR ACCEPTANCE OF CONTRACT.



UNIT	STD UNIT WEIGHT *		CORNER WEIGHT (A)		CORNER WEIGHT (B)		CORNER WEIGHT (C)		CORNER WEIGHT (D)		C.G.					
	LBS.	KG.	LBS.	KG.	LBS.	KG.	LBS.	KG.	LBS.	KG.	X	Y				
50LC24	2248	1022.0	458.3	208.3	537.5	244.3	676.2	307.4	576.5	262.1	48.1	1219.201	85.1	1/32 [2159.791]	19 [482.6]	Z
50LC26	2393	1087.6	534.0	242.7	595.1	270.5	666.0	302.7	597.6	271.6	45.1	1/2 [1155.70]	83.1	1/32 [2108.99]	19 [482.6]	Z

\* STANDARD UNIT WEIGHT IS WITHOUT ELECTRIC HEAT AND WITHOUT PACKAGING. FOR OTHER OPTIONS AND ACCESSORIES, REFER TO THE PRODUCT DATA CATALOG.

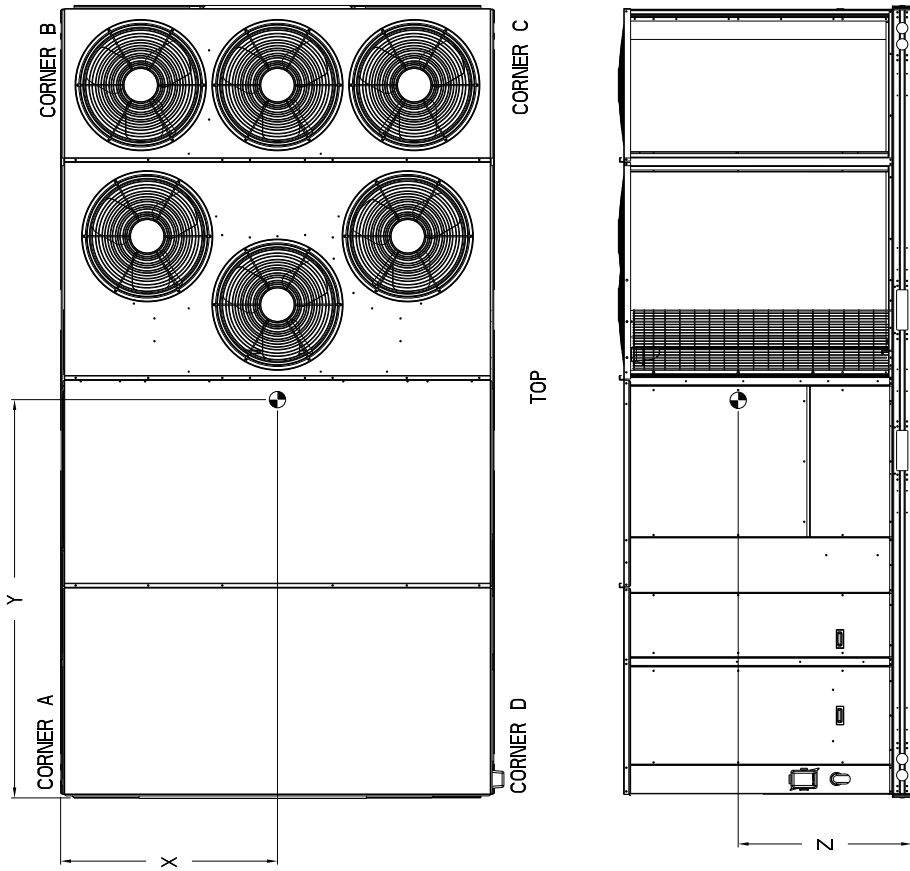

SHEET	DATE	SUPERCEDES	REV
3 OF 3	11/08/12	08/10/12	50LC500668
50LC 24, 26 SINGLE ZONE ELECTRICAL COOLING WITH ELECTRIC HEAT			-

Fig. 4 - Unit Dimensional Drawing – 24 and 26 Size Units (cont)

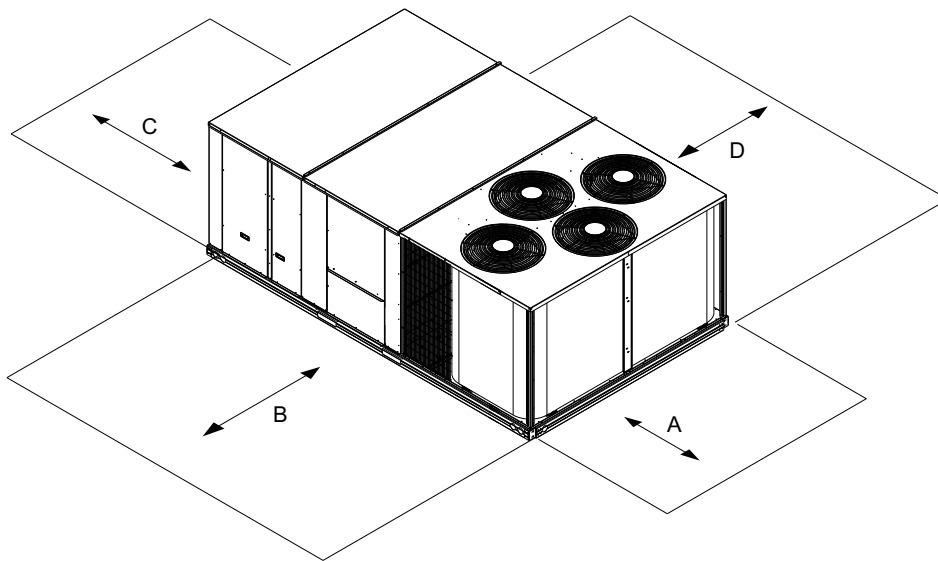

C12392

LOCATION	DIMENSION	CONDITION
A	36-in (914 mm)	• Recommended clearance for air flow and service
B	42-in (1067 mm)	• Recommended clearance for air flow and service
C	18-in (457 mm)	• No Convenience Outlet • No Economizer • No field-installed disconnect on economizer hood side (Factory-installed disconnect installed).
	36-in (914 mm)	• Convenience Outlet installed. • Vertical surface behind servicer is electrically non-conductive (e.g.: wood, fiberglass).
	42-in (1067 mm)	• Convenience Outlet installed. • Vertical surface behind servicer is electrically conductive (e.g.: metal, masonry).
	96-in (2438 mm)	• Economizer and/or Power Exhaust installed. • Check for sources of flue products with 10 feet (3 meters) of economizer fresh air intake.
D	42-in (1067 mm)	• Recommended clearance for service.

**NOTE:** Unit not designed to have overhead obstruction. Contact Application Engineering for guidance on any application planning overhead obstruction or for vertical clearances.

**Fig. 5 - Service Clearance Dimensional Drawing**

**Table 1 – Operating Weights**

50LC-*	UNIT LB (KG)				
	14	17	20	24	26
Base Unit	1754 (797.3)	1996 (907.3)	2102 (955.7)	2248 (1022.0)	2393 (1087.6)
Economizer	246 (112)	246 (112)	246 (112)	246 (112)	246 (112)
Powered Outlet	35 (16)	35 (16)	35 (16)	35 (16)	35 (16)
Curb					
14-in/356 mm	240 (109)	240 (109)	255 (116)	255 (116)	273 (124)
24-in/610 mm	340 (154)	340 (154)	355 (161)	355 (161)	355 (161)

## INSTALLATION

### Jobsite Survey

Complete the following checks before installation.

1. Consult local building codes and the NEC (National Electrical Code) ANSI/NFPA 70 for special installation requirements.
2. Determine unit location (from project plans) or select unit location.
3. Check for possible overhead obstructions which may interfere with unit lifting or rigging.

### Step 1 — Plan for Unit Location

Select a location for the unit and its support system (curb or other) that provides for the minimum clearances required for safety. This includes the clearance to combustible surfaces, unit performance and service access below, around and above unit as specified in unit drawings. See Fig. 5.

**NOTE:** Consider also the effect of adjacent units.

Unit may be installed directly on wood flooring or on Class A, B, or C roof-covering material when roof curb is used. Do not install unit in an indoor location. Do not locate air inlets near exhaust vents or other sources of contaminated air.

Although unit is weatherproof, avoid locations that permit water from higher level runoff and overhangs to fall onto the unit.

Select a unit mounting system that provides adequate height to allow installation of condensate trap per requirements. Refer to Step 9 — Install External Condensate Trap and Line – for required trap dimensions.

### Roof Mount —

Check building codes for weight distribution requirements. Unit operating weight is shown in Table 1.

### Step 2 — Plan for Sequence of Unit Installation

The support method used for this unit will dictate different sequences for the steps of unit installation. For example, on curb-mounted units, some accessories must be installed on the unit before the unit is placed on the curb. Review the following for recommended sequences for installation steps.

#### Curb-mounted installation —

- Install curb
- Install field-fabricated ductwork inside curb
- Install thru-base service connection fittings (affects curb and unit)
- Rig and place unit
- Remove top skid
- Install outside air hood
- Install smoke detector tube
- Install condensate line trap and piping
- Make electrical connections
- Install other accessories

#### Pad-mounted installation —

- Prepare pad and unit supports
- Rig and place unit
- Remove duct covers and top skid
- Install Return Air smoke detector sensor tube
- Install field-fabricated ductwork at unit duct openings
- Install outside air hood
- Install condensate line trap and piping
- Make electrical connections
- Install other accessories

#### Frame-mounted installation —

Frame-mounted applications generally follow the sequence for a curb installation. Adapt as required to suit specific installation plan.

### Step 3 — Inspect Unit

Inspect unit for transportation damage. File any claim with transportation agency.

Confirm before installation of unit that voltage, amperage and circuit protection requirements listed on unit data plate agree with power supply provided.

On units with hinged panel option, check to be sure all latches are tight and in closed position.

Locate the carton containing the outside air hood parts; see Fig. 6 and 14. Do not remove carton until unit has been rigged and located in final position.

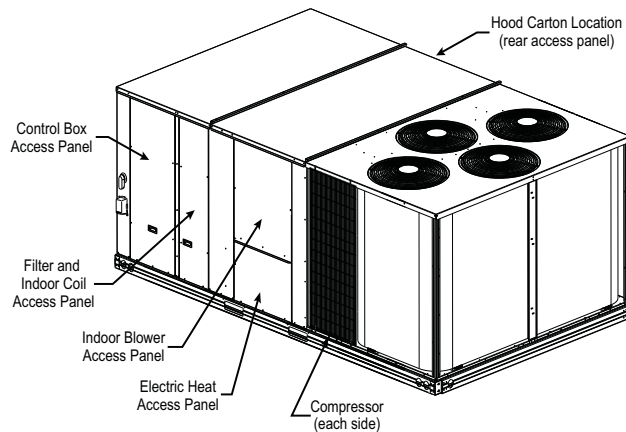

C11155

Fig. 6 - Typical Access Panel and Compressor Locations

### Step 4 — Provide Unit Support

#### Roof Curb Mount —

Accessory roof curb details and dimensions are shown in Fig. 8, 9 and 10. Assemble and install accessory roof curb in accordance with instructions shipped with the curb.

**NOTE:** The gasketing of the unit to the roof curb is critical for a watertight seal. Install gasket supplied with the roof curb as shown in Fig. 8, 9 and 10. Improperly applied gasket can also result in air leaks and poor unit performance.

Curb should be level. This is necessary for unit drain to function properly. Unit leveling tolerances are shown in Fig. 7. Refer to Accessory Roof Curb Installation Instructions for additional information as required.

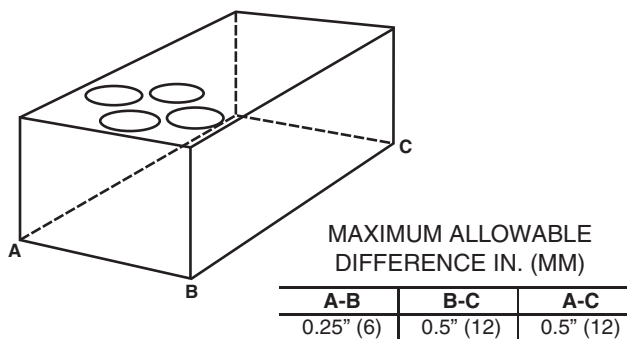

C10628

Fig. 7 - Unit Leveling Tolerances

Install insulation, cant strips, roofing felt, and counter flashing as shown. *Ductwork must be attached to curb and not to the unit. Thru-the-base power connection must be installed before the unit is set on the roof curb.*

If electric and control wiring is to be routed through the basepan, remove knockouts in basepan located in control box area of access panel; see Fig. 2, 3 or 4 for basepan knockout locations.. Attach the service connections to the basepans.

UNIT SIZE	"A"	ROOF CURB ACCESSORY
14	1'-2" [356.0] 2'-0" [610.0]	CRRFCURB045A00 CRRFCURB046A00

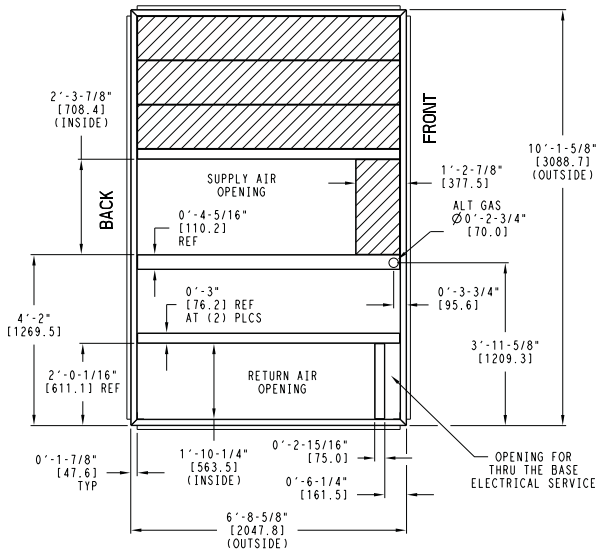

NOTES:

- 1 ROOF CURB ACCESSORY IS SHIPPED UNASSEMBLED.
- 2 DIMENSIONS IN ( ) ARE IN MILLIMETERS.
- 3 ROOF CURB GALVANIZED STEEL.
- 4 ATTACH DUCTWORK TO CURB (FLANGES ON DUCT REST ON CURB)
- 5 SERVICE CLEARANCE 4 FT ON EACH SIDE

➔ DIRECTION OF AIR FLOW

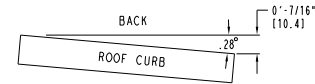

MAX CURB LEVELING TOLERANCES

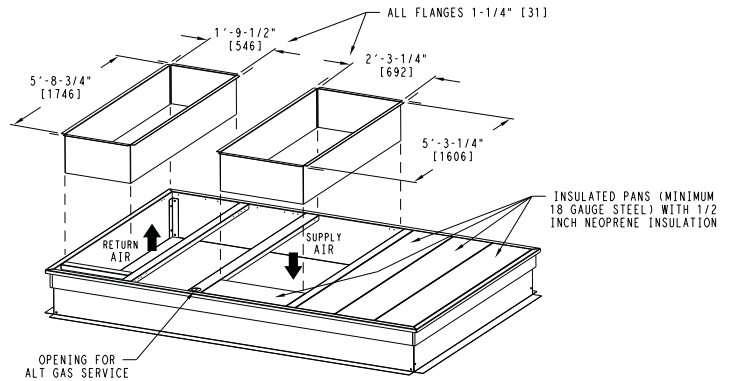
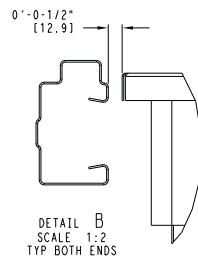
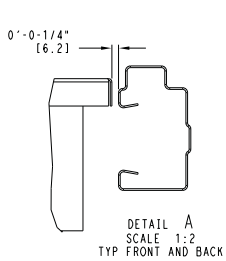
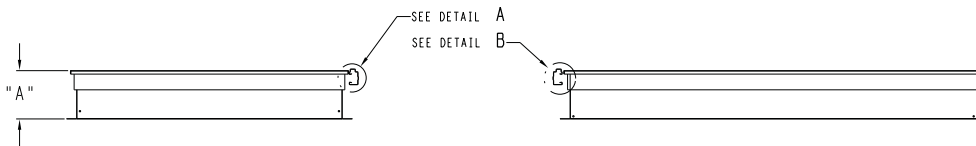
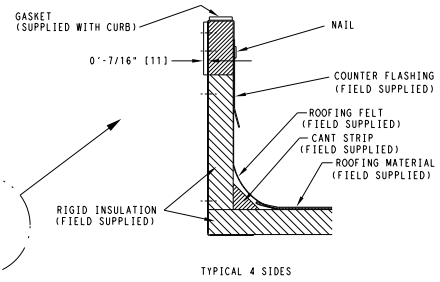
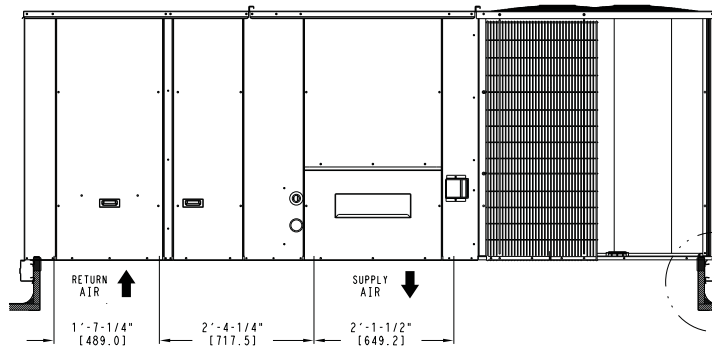
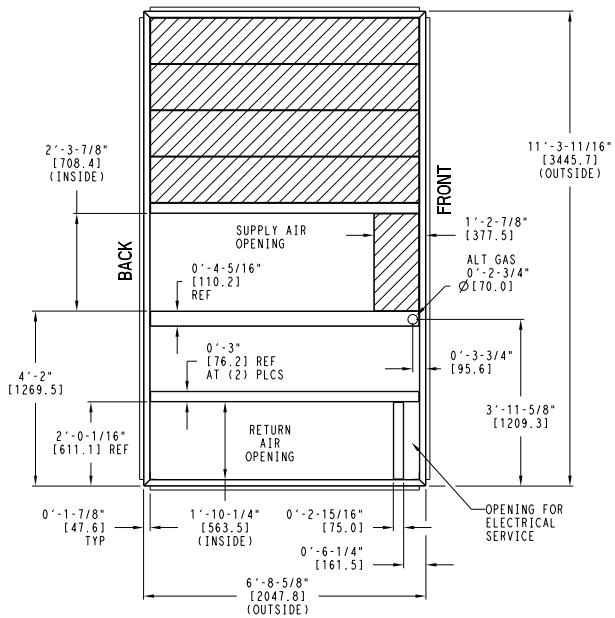

Fig. 8 - Roof Curb Details - 14 Size Unit

C13054

UNIT SIZE	"A"	ROOF CURB ACCESSORY
17, 20	1'-2" [356.0] 2'-0" [610.0]	CRRFCURB047A00 CRRFCURB048A00



- NOTES:
- 1 ROOF CURB ACCESSORY IS SHIPPED UNASSEMBLED.
  - 2 DIMENSIONS IN [ ] ARE IN MILLIMETERS.
  - 3 ROOF CURB GALVANIZED STEEL.
  - 4 ATTACH DUCTWORK TO CURB (FLANGES ON DUCT REST ON CURB)
  - 5 SERVICE CLEARANCE 4 FT ON EACH SIDE

➔ DIRECTION OF AIR FLOW

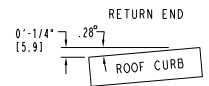
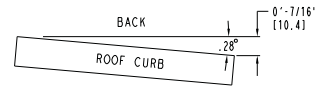

MAX CURB LEVELING TOLERANCES

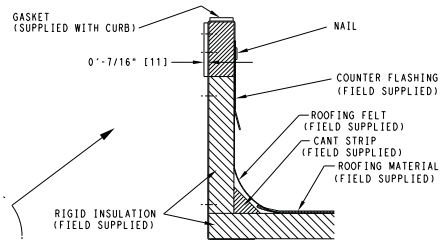
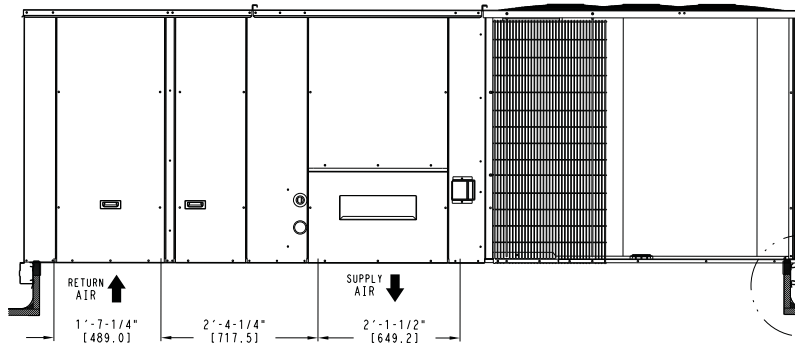

TYPICAL 4 SIDES

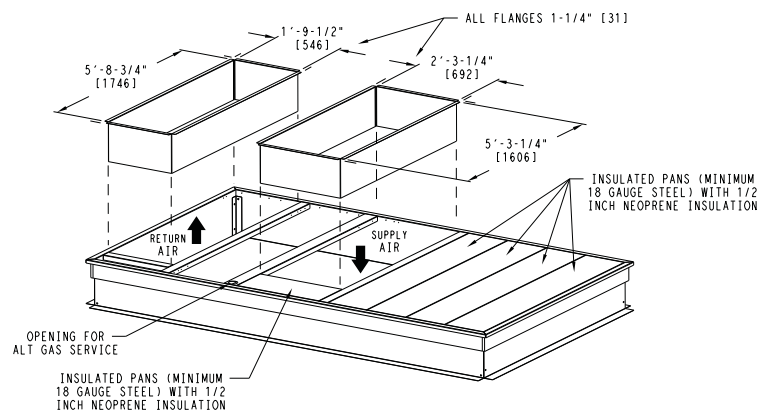
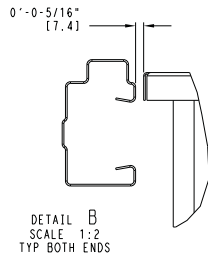
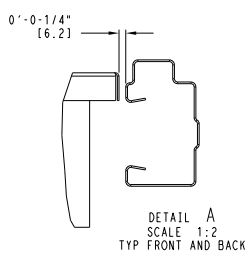
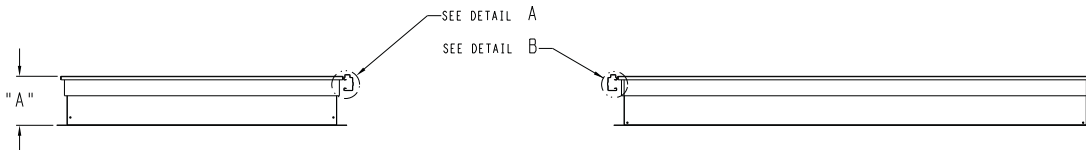
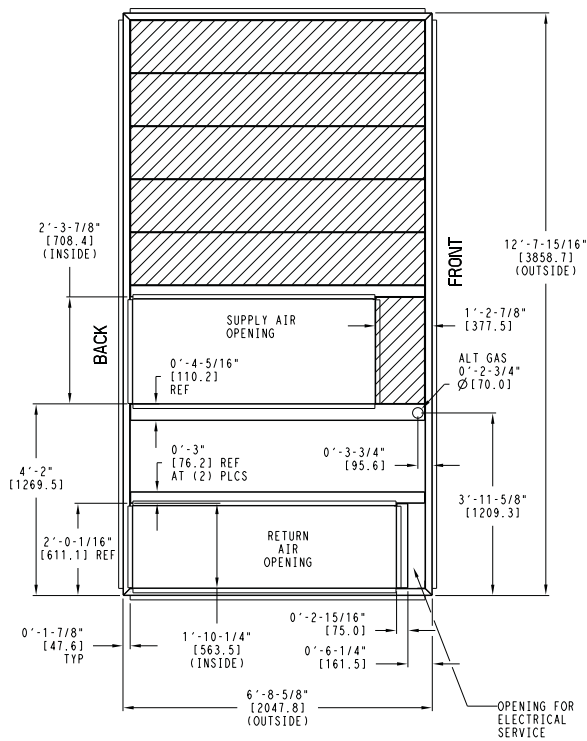

Fig. 9 - Roof Curb Details – 17 and 20 Size Units

C13055



UNIT SIZE	"A"	ROOF CURB ACCESSORY
24, 26	1'-2" [356.0] 2'-0" [610.0]	CRRFCURB049A00 CRRFCURB050A00



- NOTES:
- 1 ROOF CURB ACCESSORY IS SHIPPED UNASSEMBLED.
  - 2 BOLT HEADS TO BE ON INSIDE OF FLANGE. CLEARANCE IS [11] 0-0-7/16" TYP ALL CORNERS.
  - 3 DIMENSIONS IN [ ] ARE IN MILLIMETERS.
  - 4 ROOF CURB GALVANIZED STEEL.
  - 5 ATTACH DUCTWORK TO CURB (FLANGES ON DUCT REST ON CURB)
  - 6 SERVICE CLEARANCE 4 FT ON EACH SIDE
  - 7 GAS SERVICE PLATE IS PART OF A SEPERATELY SHIPPED ACCESSORY PACKAGE.
  - 8 GAS SERVICE PLATE CAN BE USED WITH EITHER ACCESSORY ROOFCURB.
- ➔ DIRECTION OF AIR FLOW

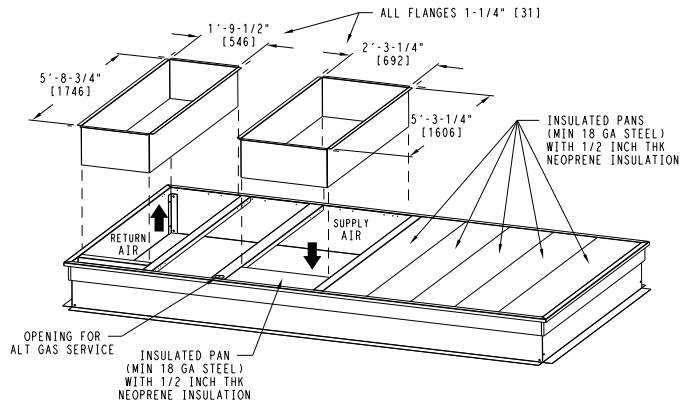
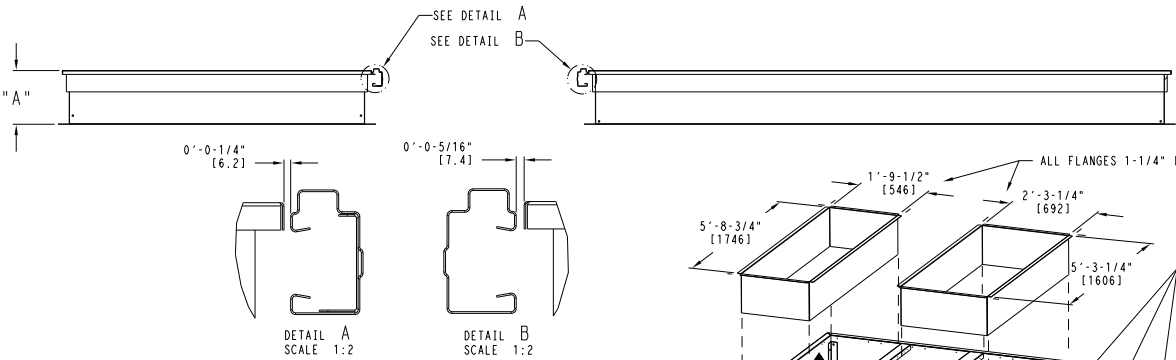
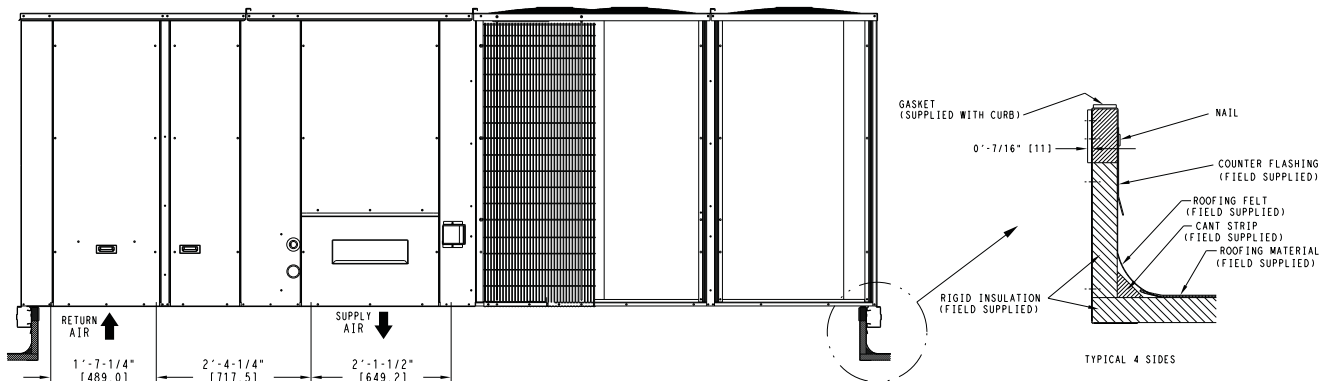
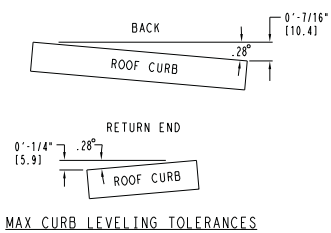

Fig. 10 - Roof Curb Details – 24 and 26 Size Units

C13056

### Slab Mount (Horizontal Units Only) —

Provide a level concrete slab that extends a minimum of 6-in. (150 mm) beyond unit cabinet. Install a gravel apron in front of condenser coil air inlet to prevent grass and foliage from obstructing airflow.

**NOTE:** Horizontal units may be installed on a roof curb if required.

### Alternate Unit Support (In Lieu of Curb or Slab Mount) —

A non-combustible sleeper rail can be used in the unit curb support area. If sleeper rails cannot be used, support the long sides of the unit with a minimum of 4 equally spaced 4-in. x 4-in. (102 mm x 102 mm) pads on each side. Locate pads so that they support the rails. Make sure to avoid the fork openings.

### Step 5 — Field Fabricate Ductwork

Cabinet return-air static pressure (a negative condition) shall not exceed 0.5 in. wg (87 Pa) with economizer or without economizer.

For vertical ducted applications, secure all ducts to roof curb and building structure. *Do not connect ductwork to unit.*

Fabricate supply ductwork so that the cross sectional dimensions are equal to or greater than the unit supply duct opening dimensions for the first 18 in. (458 mm) of duct length from the unit basepan.

Insulate and weatherproof all external ductwork, joints, and roof openings with counter flashing and mastic in accordance with applicable codes.

Ducts passing through unconditioned spaces must be insulated and covered with a vapor barrier.

If a plenum return is used on a vertical unit, the return should be ducted through the roof deck to comply with applicable fire codes.

## ⚠ CAUTION

### PROPERTY DAMAGE HAZARD

Failure to follow this caution may result in damage to roofing materials.

Membrane roofs can be cut by sharp sheet metal edges. Be careful when placing any sheet metal parts on such roof.

### For units with optional or accessory electric heaters:

Minimum clearance is not required around ductwork.

### Step 6 — Rig and Place Unit

Keep unit upright and do not drop. Spreader bars are not required if top crating is left on unit. Rollers may be used to move unit across a roof. Level by using unit frame as a reference. See Table 1 (on page 13) and Fig. 11 for additional information.

Lifting holes are provided in base rails as shown in Fig. 11. Refer to rigging instructions on unit.

## ⚠ CAUTION

### UNIT DAMAGE HAZARD

Failure to follow this caution may result in equipment damage.

All panels must be in place when rigging. Unit is not designed for handling by fork truck when packaging is removed.

Before setting the unit onto the curb, recheck gasketing on curb.

### Positioning on Curb —

Position unit on roof curb so that the following clearances are maintained:  $\frac{1}{4}$  in. (6 mm) clearance between the roof curb and the base rail inside the right and left,  $\frac{1}{2}$  in. (12 mm) clearance between the roof curb and the base rail inside the front and back. This will result in the distance between the roof curb and the base rail being approximately equal to Detail A and Detail B in Fig. 8, 9 and 10.

Do not attempt to slide unit on curb after unit is set. Doing so will result in damage to the roof curb seal.

Although unit is weatherproof, guard against water from higher level runoff and overhangs.

After unit is in position, remove rigging skids and shipping materials.

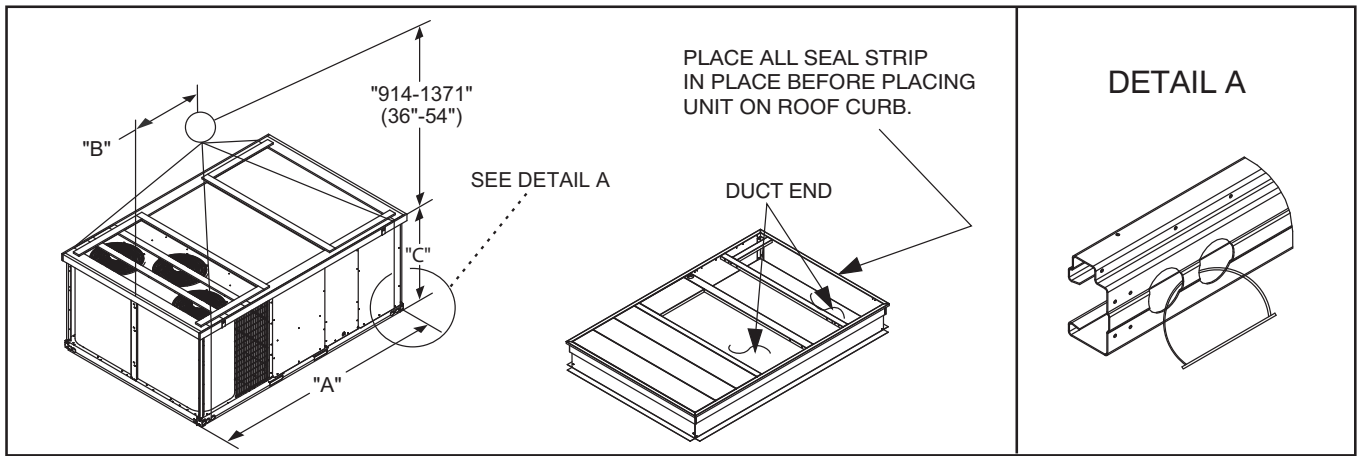

C09107

UNIT	MAX WEIGHT		DIMENSIONS					
			A		B		C	
	LB	KG	IN	MM	IN	MM	IN	MM
50LC-*14	2004	911	127.8	3249	59.1	1501	52.3	1328
50LC-*17	2246	1021	141.5	3595	65.5	1664	60.3	1532
50LC-*20	2353	1069	141.5	3595	65.5	1664	60.3	1532
50LC-*24	2499	1136	157.8	4007	72.8	1849	60.3	1532
50LC-*26	2643	1201	157.8	4007	72.8	1849	60.3	1532

**NOTES:**

1. Dimensions in ( ) are in inches.
2. Hook rigging shackles through holes in base rail, as shown in detail "A." Holes in base rails are centered around the unit center of gravity. Use wooden top to prevent rigging straps from damaging unit.

**Fig. 11 - Rigging Details**

**Step 7 — Horizontal Duct Connection**

Refer to Fig. 2, 3 and 4 for locations and sizes of the horizontal duct connections. Note that there are two different return air duct connection locations – one for unit without an economizer (on back side of unit) and a different one for unit equipped with an economizer (on left end, under the economizer hood). The supply air duct connection is on the back side. See Fig. 12 for top view depicting typical horizontal duct arrangements.

Field-supplied (3/4-inch) flanges should be attached to horizontal duct openings (see Fig. 12) and all ductwork should be secured to the flanges. Insulate and weatherproof all external ductwork, joints, and roof or building openings with counter flashing and mastic in accordance with applicable codes.

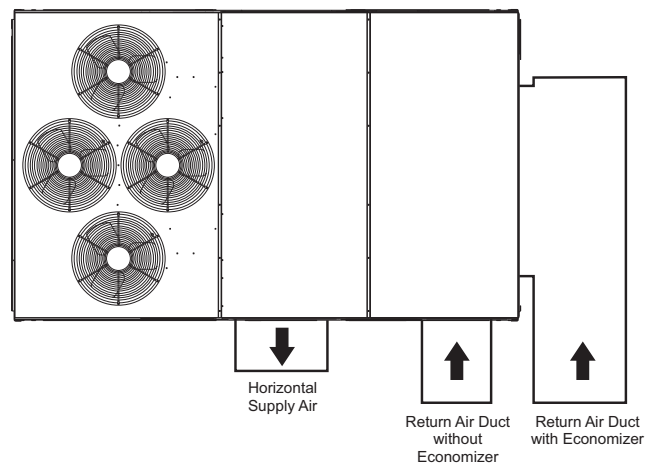

C10740

	Supply	Return without Economizer	Return with Economizer
Location	Back	Back	Left end
Height – in. (mm)	15 <sup>7</sup> / <sub>8</sub> (402)	49 <sup>3</sup> / <sub>8</sub> (1253)	18 <sup>3</sup> / <sub>8</sub> (467)
Width – in. (mm)	29 <sup>3</sup> / <sub>4</sub> (756)	23 <sup>3</sup> / <sub>8</sub> (593)	61 <sup>5</sup> / <sub>8</sub> (1564)

**Fig. 12 - Horizontal Duct Opening Dimensions**

## Step 8 — Install Outside Air Hood — Factory Option

The outside air hood for factory-option economizer is shipped in knock-down form and requires field assembly. The panel for the hood top is shipped on the end of the unit (see Fig. 13). The remaining parts for the hood assembly (including side panels, filters and tracks) are shipped in a carton that is secured to the rear of the blower assembly. Access the carton location through rear panel (see Fig. 14).

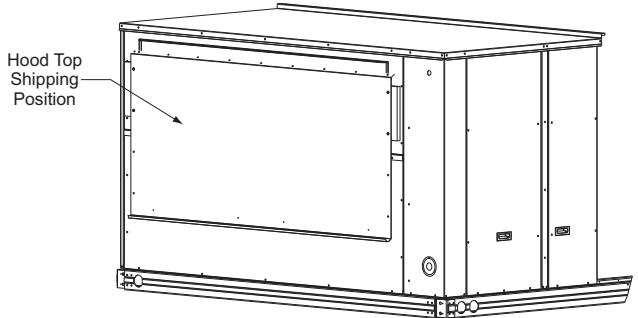

C09134

**Fig. 13 - Hood Top – Shipping Position**

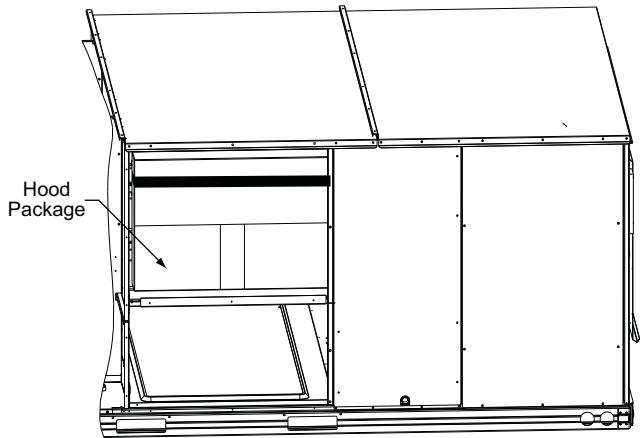

C13785

**Fig. 14 - Hood Package – Shipping Location**

### To remove the hood parts package:

1. Remove the back blower access panel.
2. Locate and cut the strap, being careful to not damage any wiring.
3. Carefully lift the hood package carton through the back blower access opening.

See Fig. 15 for identification of the various parts of the hood assembly.

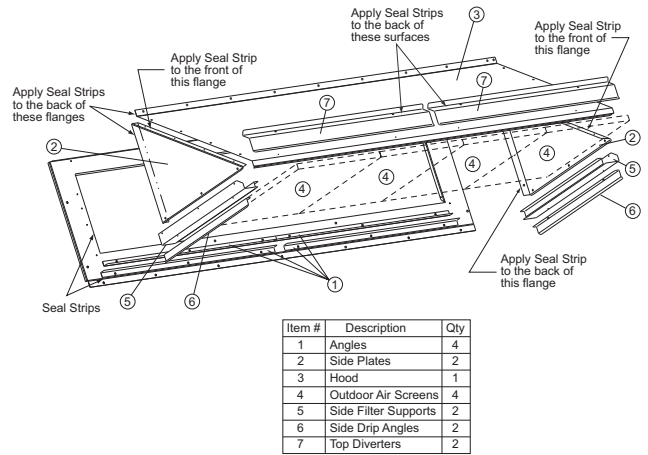

C09079

**Fig. 15 - Hood Part Identification and Seal Strip Application Areas**

### To assemble the outside air hood:

1. Remove hood top panel from shipping position on unit end.
2. Install four angles to the upper end panel using the screws provided.
3. Apply seal strip to mating flanges on the side plates of the hood (see Fig. 15).
4. Secure side plates to panel using the screws provided.
5. Apply seal strip to mating flange of the hood (see Fig. 15).
6. Secure top flange using screws provided in kit.
7. Install outdoor air screens by sliding them into the channel formed by the four angles installed in step 2. Make sure that the screens extend across the entire length of the hood.
8. Install side filter supports using the screws provided.
9. Install side drip angles using the screws provided.
10. Run a continuous length of seal strip across the hood covering the engagement holes in the lower hood.
11. Install top diverter using the screws provided.
12. On units with barometric relief, remove screws at bottom of relief damper. **Do not discard damper door.**

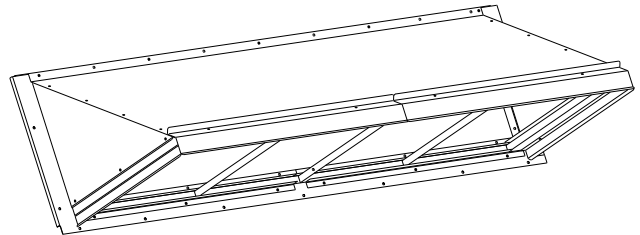

C09090

**Fig. 16 - Hood Assembly – Completed**

## Step 9 — Install External Condensate Trap and Line

The unit has one  $\frac{3}{4}$ -in. condensate drain connection on the end of the condensate pan (see Fig. 17). See Fig. 2, 3 and 4, item “E”, in the view labeled “BACK (HORIZONTAL DISCHARGE W/O ECON)” for the location of the condensate drain connection.

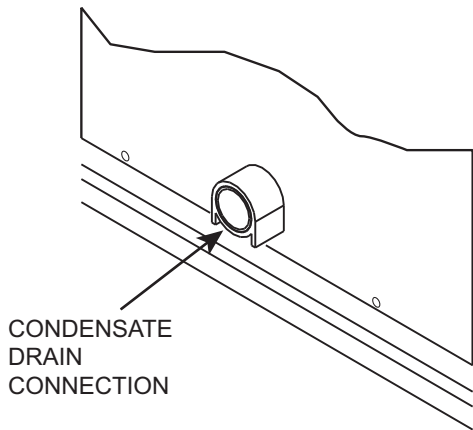

C10729

**Fig. 17 - Condensate Drain Pan Connection**

The piping for the condensate drain and external trap can be completed after the unit is in place. Hand tighten fittings to the drain pan fitting. Provide adequate support for the drain line. Failure to do so can result in damage to the drain pan. See Fig. 18.

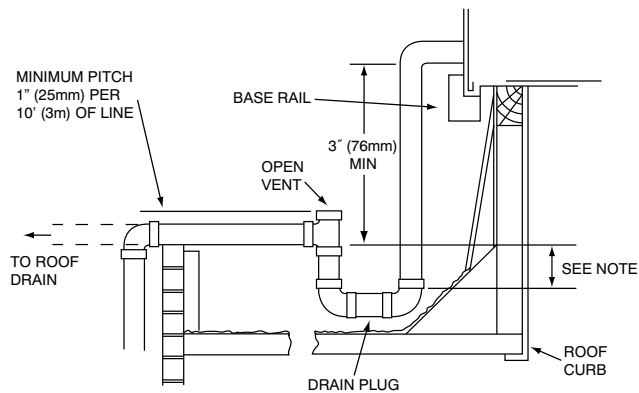

NOTE: Trap should be deep enough to offset maximum unit static difference. A 4" (102mm) trap is recommended.

C11291

**Fig. 18 - Condensate Drain Piping Details**

All units must have an external trap for condensate drainage. Install a trap at least 4-in. (102 mm) deep and protect against freeze-up. If drain line is installed downstream from the external trap, pitch the line away from the unit at 1-in. per 10 ft (25 mm in 3 m) of run. Do not use a pipe size smaller than the unit connection ( $\frac{3}{4}$ -in.).

## Step 10 — Make Electrical Connections

### ⚠ WARNING

#### ELECTRICAL SHOCK HAZARD

Failure to follow this warning could result in personal injury or death.

*Do not use gas piping as an electrical ground.* Unit cabinet must have an uninterrupted, unbroken electrical ground to minimize the possibility of personal injury if an electrical fault should occur. This ground may consist of electrical wire connected to unit ground lug in control compartment, or conduit approved for electrical ground when installed in accordance with NEC (National Electrical Code); ANSI/NFPA 70, latest edition (in Canada, Canadian Electrical Code CSA [Canadian Standards Association] C22.1), and local electrical codes.

NOTE: Field-supplied wiring shall conform with the limitations of minimum 63°F (33°C) rise.

#### Field Power Supply —

If equipped with optional Powered Convenience Outlet: The power source leads to the convenience outlet's transformer primary are not factory connected. Installer must connect these leads according to required operation of the convenience outlet. If an always-energized convenience outlet operation is desired, connect the source leads to the line side of the unit-mounted disconnect. (Check with local codes to ensure this method is acceptable in your area.) If a de-energize via unit disconnect switch operation of the convenience outlet is desired, connect the source leads to the load side of the unit disconnect. On a unit without a unit-mounted disconnect or HACR, connect the source leads to the terminal block with unit field power leads. See Fig. 19.

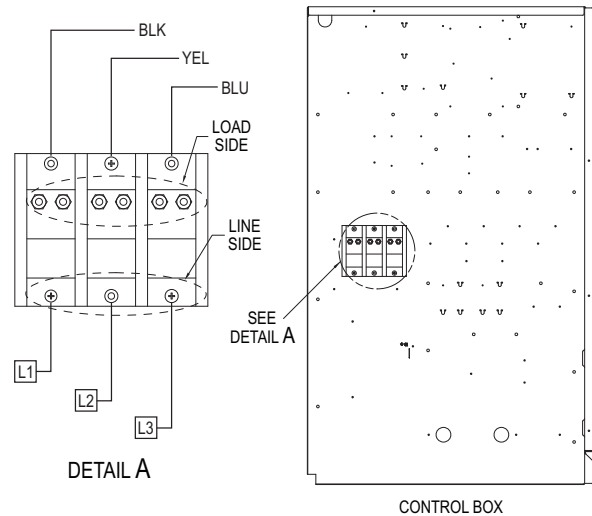

C11181

**Fig. 19 - Location of TB1**

Field power wires are connected to the unit at line-side pressure lugs on the terminal block (see wiring diagram label for control box component arrangement) or at factory-installed option non-fused disconnect switch or HACR breaker. Use copper conductors only.

HIGH TIER PAC CONTROL 208/230V, 460V, 575V

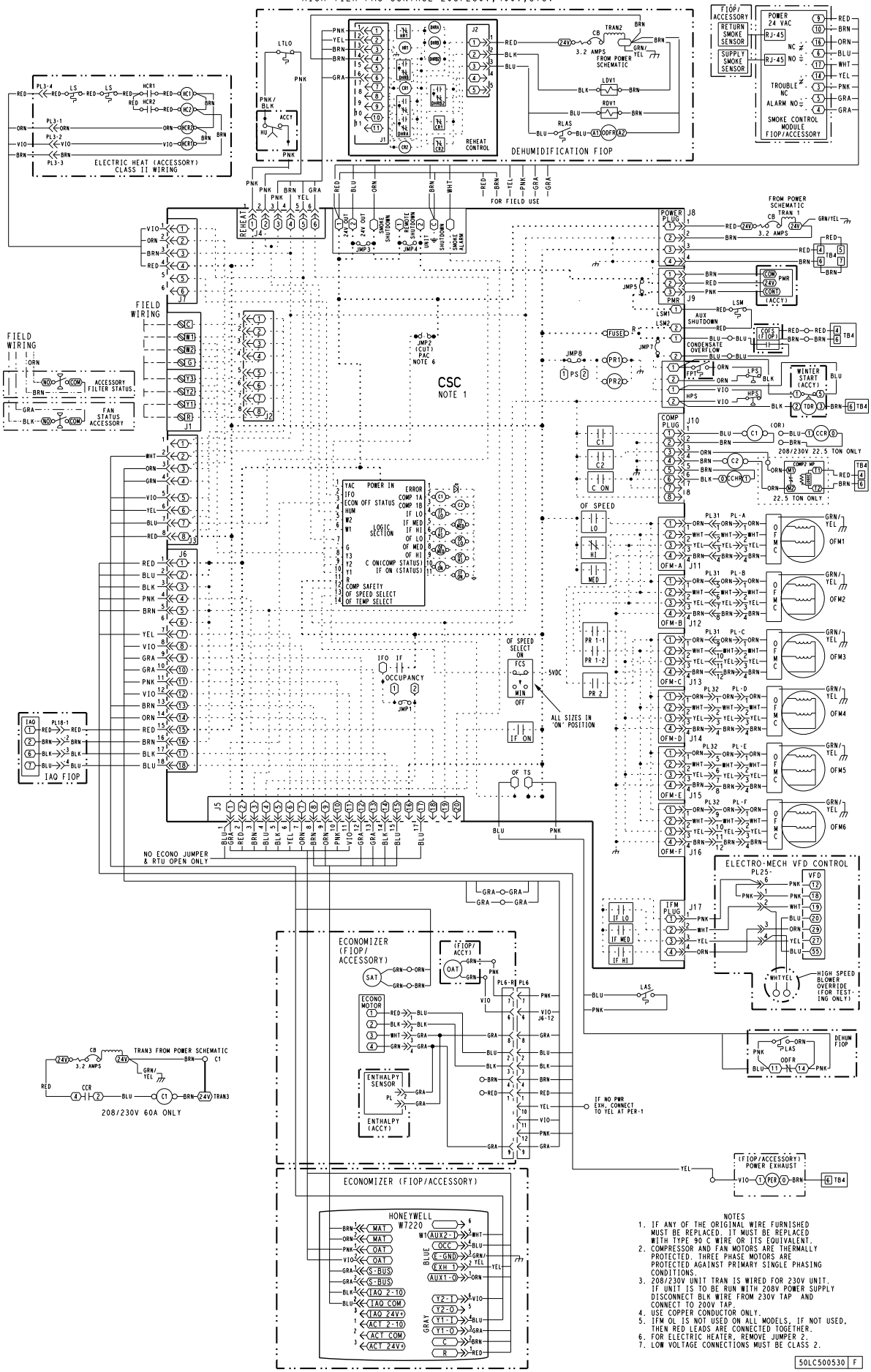

- NOTES
1. IF ANY OF THE ORIGINAL WIRE FURNISHED MUST BE REPLACED, IT MUST BE REPLACED WITH TYPE 90 C WIRE OR ITS EQUIVALENT.
  2. COMPRESSOR AND FAN MOTORS ARE THERMALLY PROTECTED. THREE PHASE MOTORS ARE PROTECTED AGAINST PRIMARY SINGLE PHASING CONDITIONS.
  3. 208/230V UNIT TRANS IS WIRED FOR 230V UNIT. IF UNIT IS TO BE RUN WITH 208V POWER SUPPLY DISCONNECT BLK WIRE FROM 230V TAP AND CONNECT TO 200V TAP.
  4. USE COPPER CONDUCTOR ONLY.
  5. IF W/O IS NOT USED ON ALL MODELS, IF NOT USED, THEN RED LEADS ARE CONNECTED TOGETHER.
  6. FOR ELECTRIC HEATER, REMOVE JUMPER 2.
  7. LOW VOLTAGE CONNECTIONS MUST BE CLASS 2.

Fig. 20 - 50LC 14-26 Electro-mechanical Control Wiring Diagram

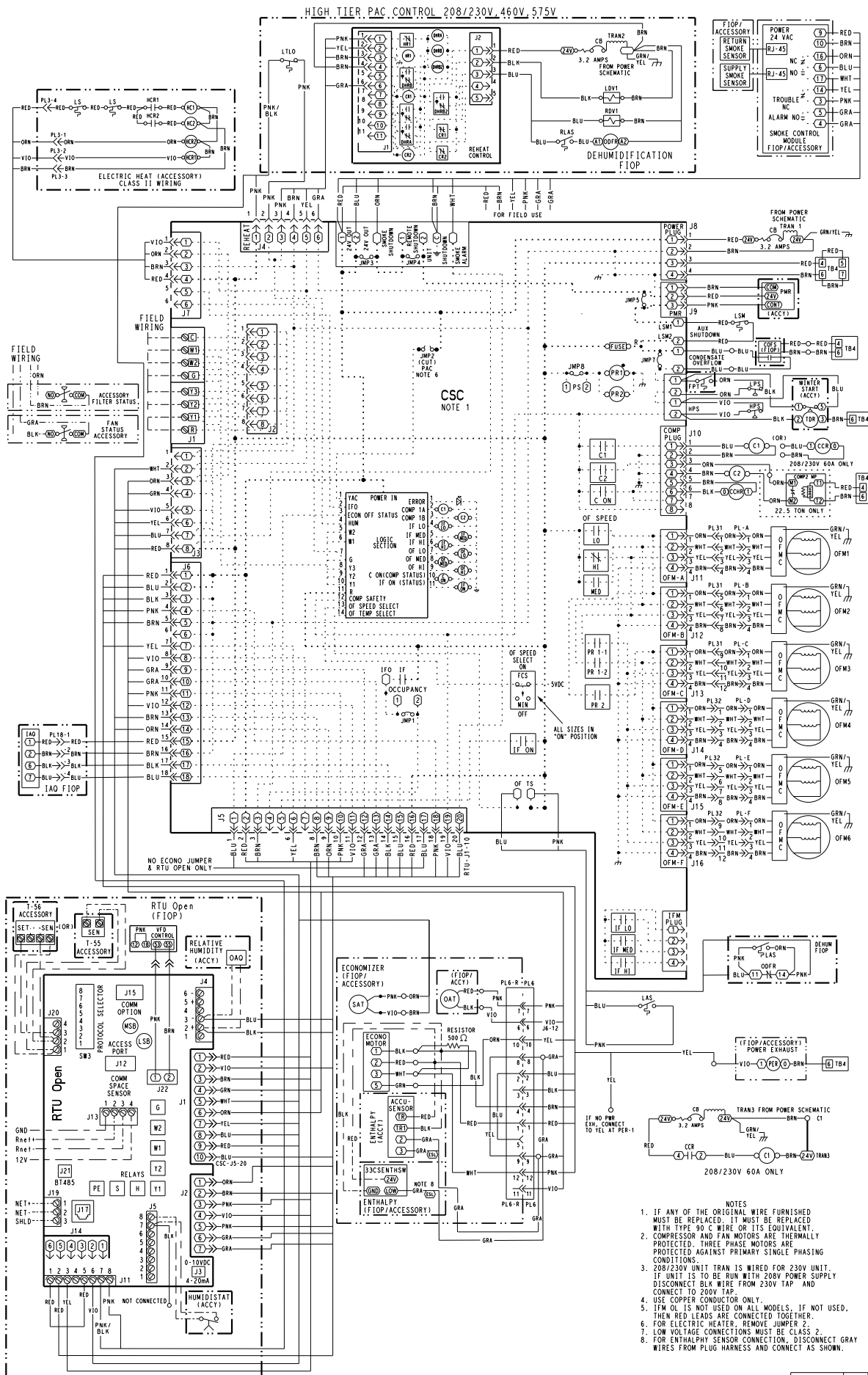
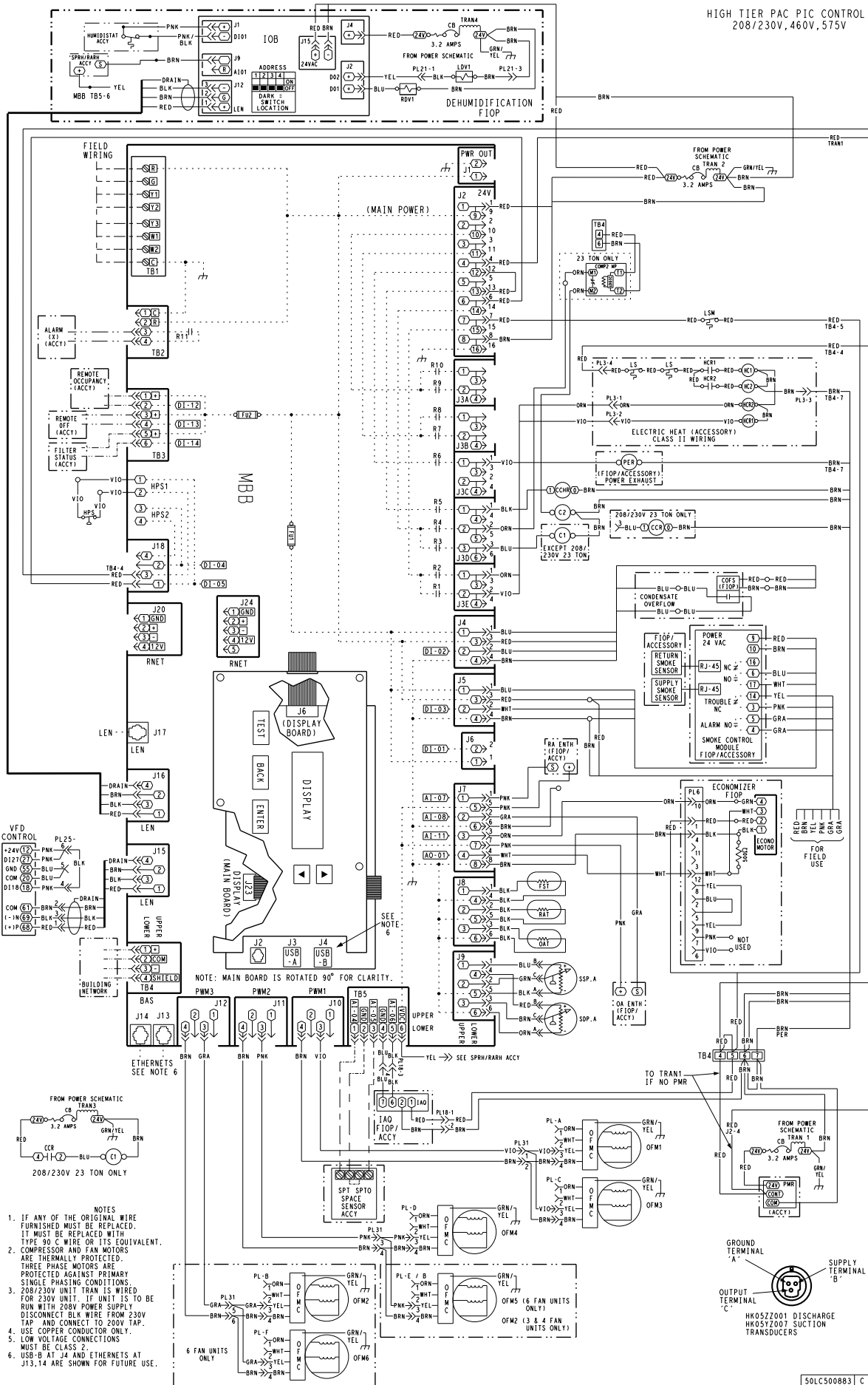

Fig. 21 - 50LC 14-26 RTU Open Control Wiring Diagram



1. IF ANY OF THE ORIGINAL WIRE FURNISHED MUST BE REPLACED, IT MUST BE REPLACED WITH TYPE 90 C WIRE OR ITS EQUIVALENT.
2. COMPRESSOR AND FAN MOTORS ARE THERMALLY PROTECTED. THREE PHASE MOTORS ARE PROTECTED AGAINST PRIMARY SINGLE PHASING CONDITIONS.
3. 208/230V UNIT TRN IS WIRED FOR 230V UNIT. IF UNIT IS TO BE RUN WITH 208V POWER SUPPLY DISCONNECT BLK WIRE FROM 230V TAP AND CONNECT TO 200V TAP.
4. USE COPPER CONDUCTOR ONLY.
5. LOW VOLTAGE CONNECTIONS MUST BE CLASS 2.
6. USB-B AT J4 AND ETHERNETS AT J13,14 ARE SHOWN FOR FUTURE USE.

Fig. 22 - 50LC 14-26 SystemVu™ Control Wiring Diagram



12.5 - 20 TON YAC, PAC POWER 208/230V 3 PH  
WITH/WITHOUT HOT GAS REHEAT FIOF

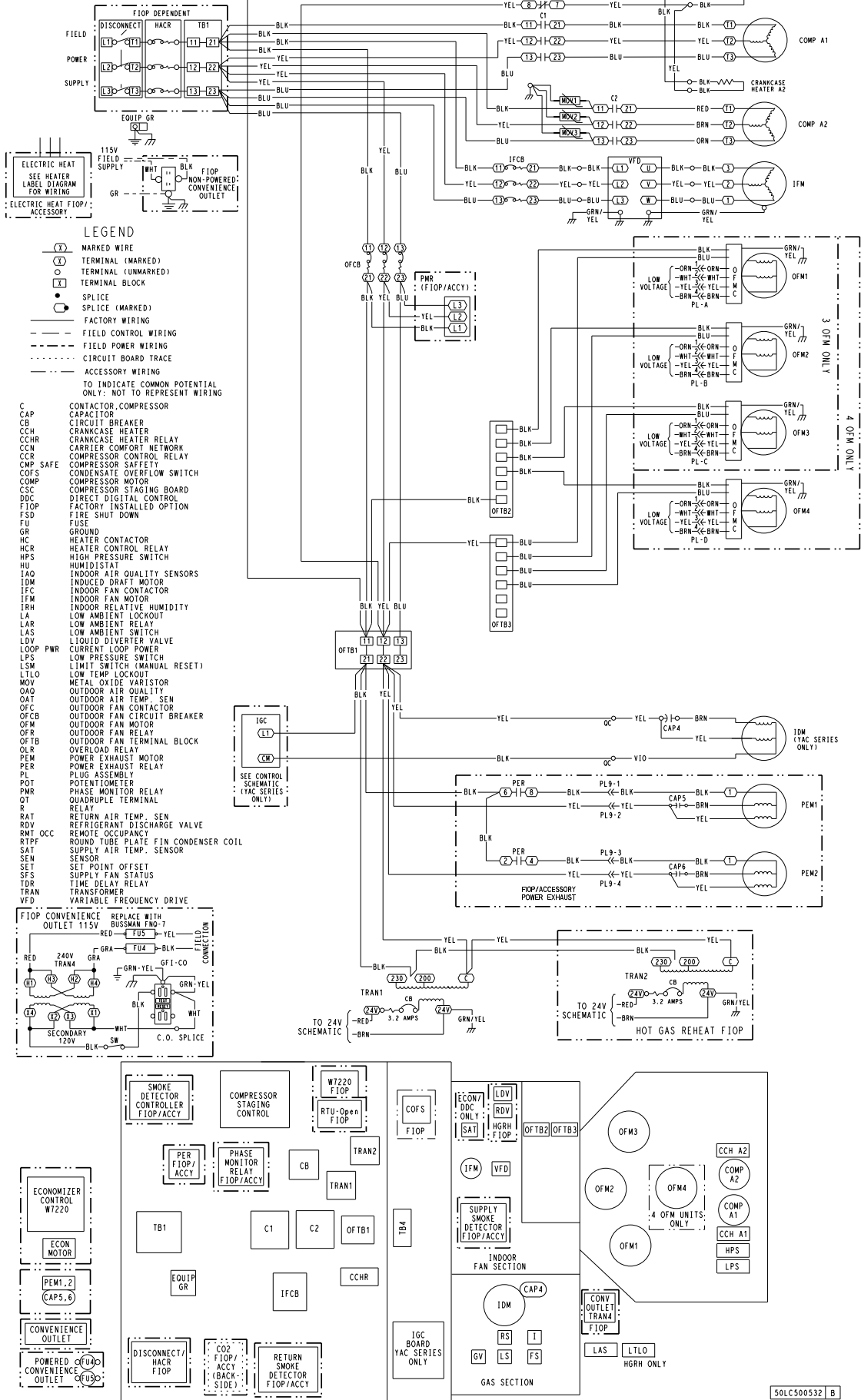

Fig. 23 - Typical Power Wiring Diagram Electro-mechanical and RTU Open Controls, 50LC 14-24 Units 208/230V Shown

12.5 - 22.5 TON YAC, PAC POWER 460,575V 3 PH  
WITH/WITHOUT HOT GAS REHEAT FIOP

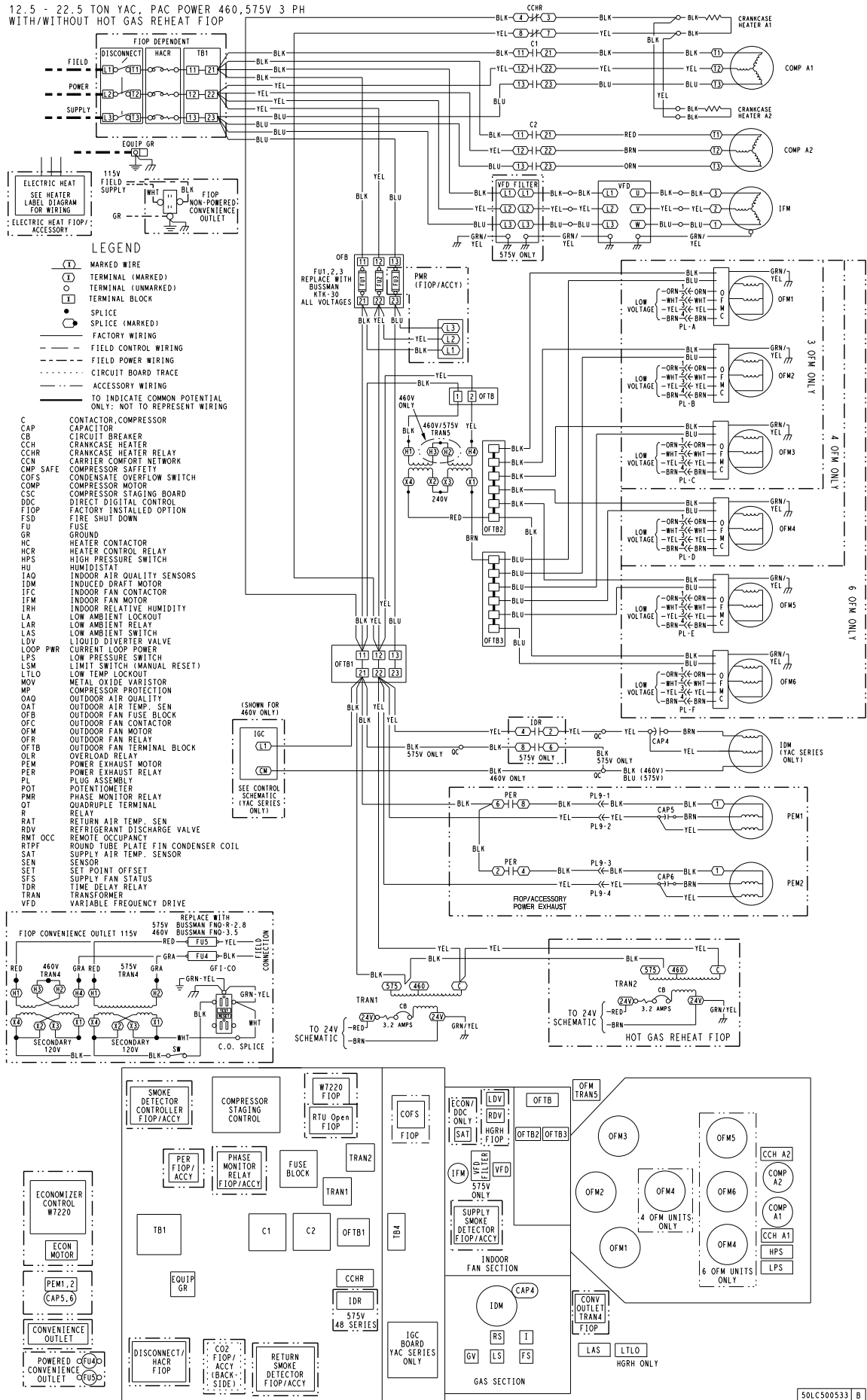
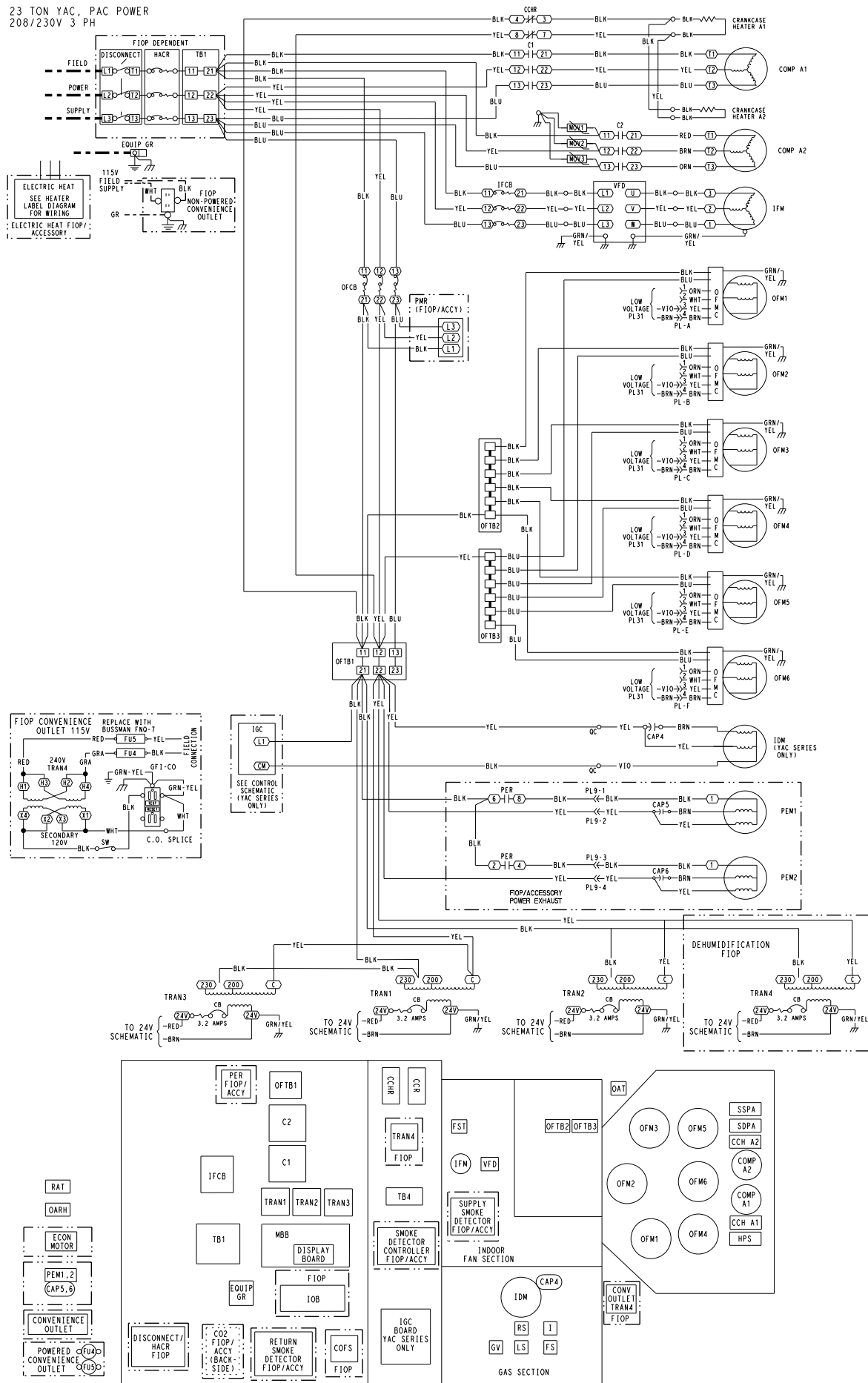

Fig. 24 - Typical Power Wiring Diagram Electro-mechanical and RTU Open Controls, 50LC 14-24 Units 460V, 575V Shown

23 TON YAC, PAC POWER  
208/230V 3 PH



50LC500886 | A

Fig. 25 - Typical Power Wiring Diagram, SystemVu™ Controls, 50LC 26 Unit 208/230V Shown

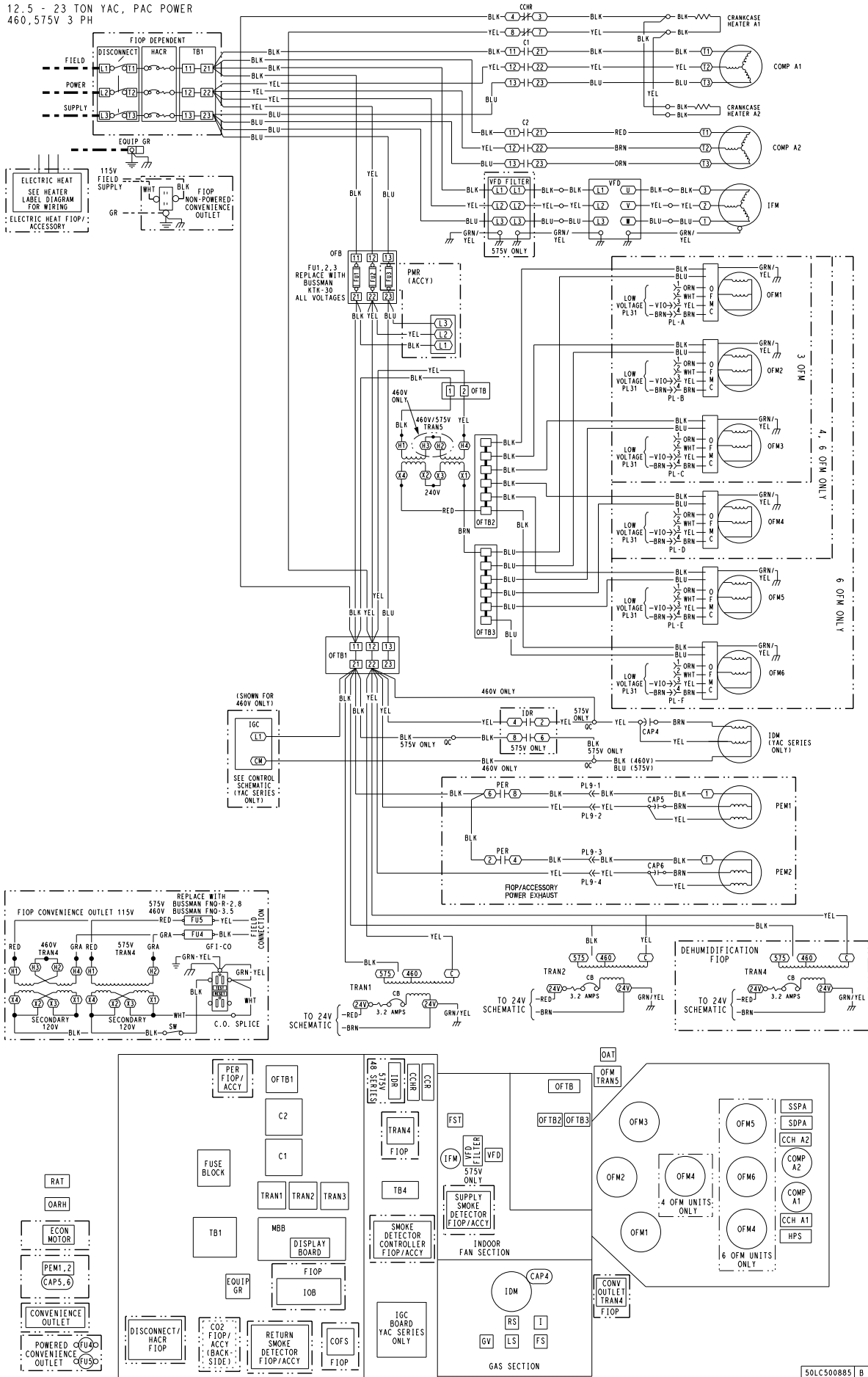

Fig. 26 - Typical Power Wiring Diagram, SystemVu™ Controls, 50LC 14-24 Units 460V, 575V Shown

**NOTE:** Make field power connections directly to line connection pressure lugs only.

⚠ **WARNING**

**FIRE HAZARD**

Failure to follow this warning could result in intermittent operation or performance satisfaction.

Do not connect aluminum wire between disconnect switch and air conditioning unit. Use only copper wire. (See Fig. 27.)

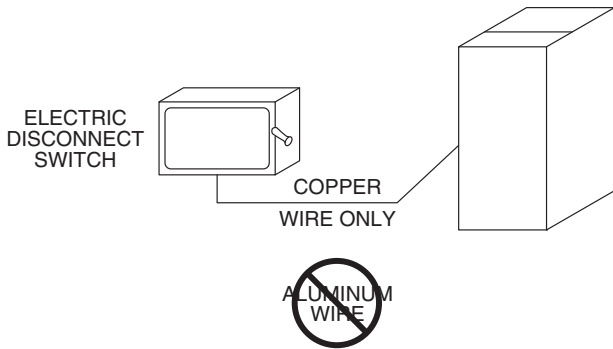

**Fig. 27 - Disconnect Switch and Unit**

A93033

**Units without Factory-Installed Non-Fused Disconnect or HACR —**

When installing units, provide a disconnect switch per NEC (National Electrical Code) of adequate size. Disconnect sizing data is provided on the unit informative plate. Locate on unit cabinet or within sight of the unit per national or local codes. Do not cover unit informative plate if mounting the disconnect on the unit cabinet.

**Units with Factory-Installed Non-Fused Disconnect or HACR—**

The factory-installed option non-fused disconnect switch (NFD) or HACR is located in the main control box. The manual switch handle and shaft are shipped in the control box and must be mounted on the corner post adjacent to the control box (see Fig. 28 or 29). Note that the tape covering the hole for the shaft in the corner post must be removed prior to handle and shaft installation.

**To field install the NFD shaft and handle:**

1. Open the control box panel.
2. Make sure the NFD shipped from the factory is at OFF position (the arrow on the black handle knob or on the silver metal collar is at OFF).
3. Insert the shaft with the cross pin on the top of the shaft in the horizontal position.
4. Measure the tip of the shaft to the outside surface of the corner post to be 0.88".
5. Tighten the locking screw to secure the shaft to the NFD.
6. Turn the handle to OFF position with red arrow pointing at OFF.

7. Install the handle on to the corner post vertically with the red arrow pointing up.
8. Secure the handle to the corner post with (2) screws and lock washers supplied.

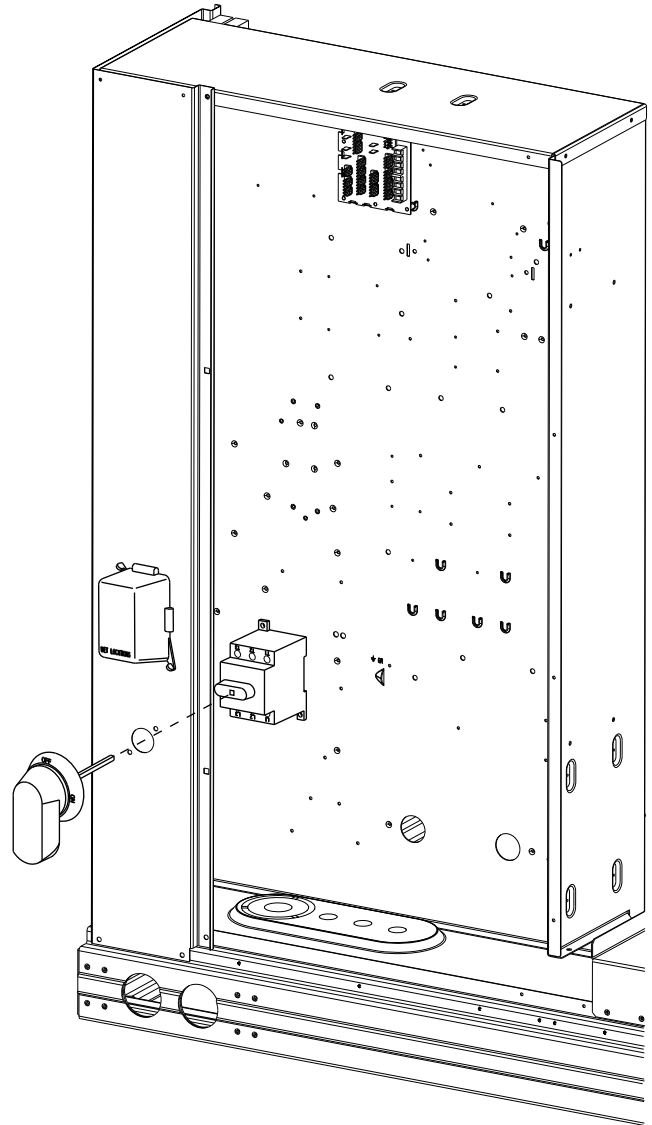

C12385

**Fig. 28 - Handle and Shaft Assembly for NFD**

**To field install the HACR shaft and handle:**

1. Open the control box panel.
2. Make sure the HACR shipped from the factory is at OFF position (the white arrow pointing at OFF).
3. Insert the shaft with the cross pin on the top of the shaft in the horizontal position.
4. Measure the tip of the shaft to the outside surface of the corner post to be 0.88".
5. Tighten the locking screw to secure the shaft to the HACR.
6. Turn the handle to OFF position with red arrow pointing at OFF.
7. Install the handle on to the corner post vertically with the red arrow pointing up.
8. Secure the handle to the corner post with (2) screws and lock washers supplied.

and 22 (see Note 3 on page 92) to determine the percent of voltage imbalance.

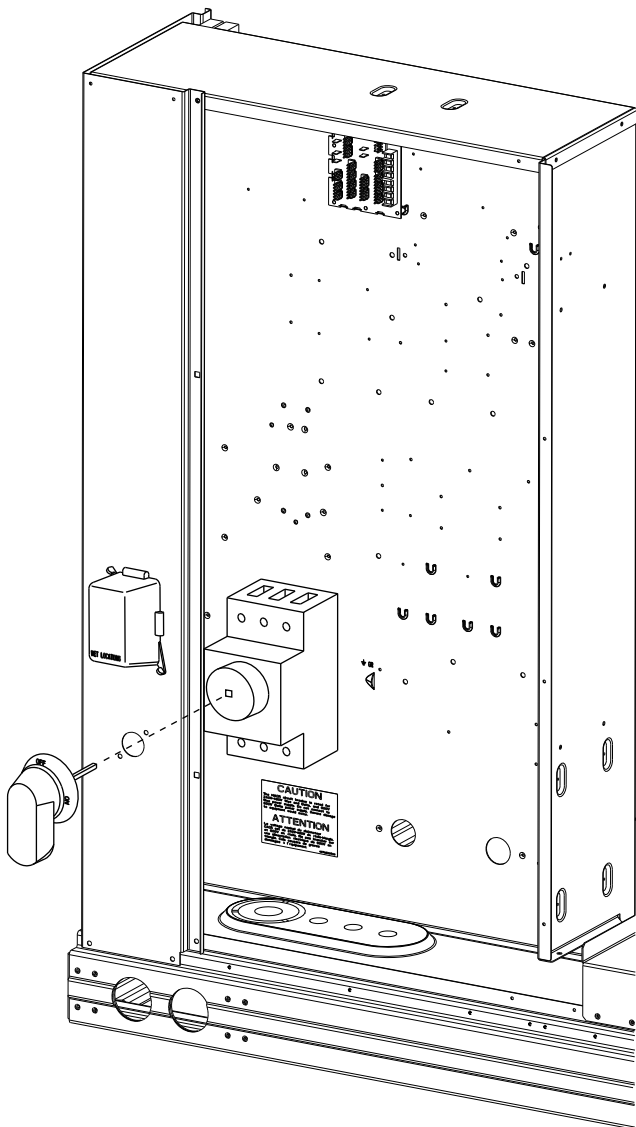

C12386

**Fig. 29 - Handle and Shaft Assembly for HACR**

**All Units -**

All field wiring must comply with NEC and all local code requirements.

Size wire based on MCA (Minimum Circuit Amps) on the unit informative plate. See Fig. 30 for power wiring connections to the unit power terminal block and equipment ground. Maximum wire size is 2/0 AWG per pole.

Provide a ground-fault and short-circuit over-current protection device (fuse or breaker) per NEC Article 440 (or local codes). Refer to unit informative data plate for MOCP (Maximum Over-current Protection) device size.

**NOTE:** Units ordered with factory-installed HACR do not need additional ground-fault and short circuit over current protection device unless required by local codes.

Voltage to compressor terminals during operation must be within voltage range indicated on unit nameplate. See Tables 21 and 22. On 3-phase units, voltages between phases must be balanced within 2% and the current within 10%. Use the formula shown in the legend for Tables 21

**⚠ CAUTION**

**UNIT DAMAGE HAZARD**

Failure to follow this caution may result in equipment damage.

Operation on improper line voltage or excessive phase imbalance constitutes abuse and may cause damage to electrical components. Such operation would invalidate any applicable Carrier warranty.

**Units Without Disconnect or HACR Option**

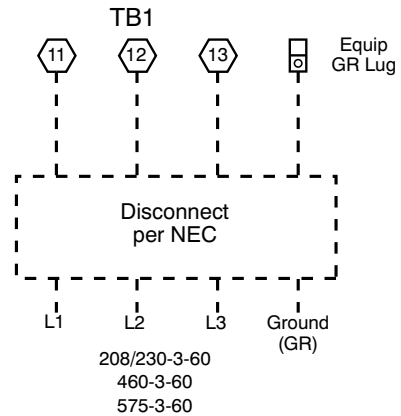

**Units With Disconnect or HACR Option**

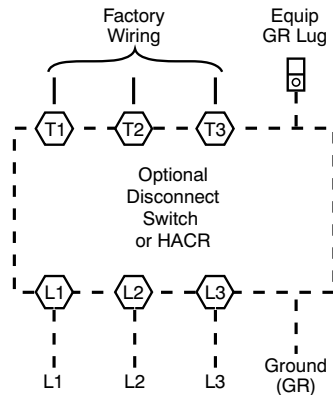

C12387

**Fig. 30 - Power Wiring Connections**

**Convenience Outlets —**

**⚠ WARNING**

**ELECTRICAL OPERATION HAZARD**

Failure to follow this warning could result in personal injury or death.

Units with convenience outlet circuits may use multiple disconnects. Check convenience outlet for power status before opening unit for service. Locate its disconnect switch, if appropriate, and open it. Lock-out and tag-out this switch, if necessary.

Two types of convenience outlets are offered on 50LC models: Non-unit powered and unit-powered. Both types provide a 125-volt GFCI (ground-fault circuit-interrupter) duplex receptacle rated at 15-A behind a hinged access cover, located on the corner panel of the unit. See Fig. 31.

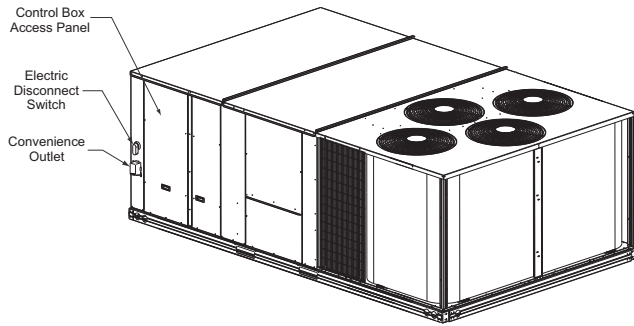

C10630

**Fig. 31 - Convenience Outlet Location**

**Installing Weatherproof Cover:** A weatherproof while-in-use cover for the factory-installed convenience outlets is now required by UL standards. This cover cannot be factory-mounted due to its depth; it must be installed at unit installation. For shipment, the convenience outlet is covered with a blank cover plate.

The weatherproof cover kit is shipped in the unit's control box. The kit includes the hinged cover, a backing plate and gasket.

**DISCONNECT ALL POWER TO UNIT AND CONVENIENCE OUTLET. LOCK-OUT AND TAG-OUT ALL POWER.**

Remove the blank cover plate at the convenience outlet; discard the blank cover.

Loosen the two screws at the GFCI duplex outlet, until approximately 1/2-in. (13 mm) under screw heads are exposed. Press the gasket over the screw heads. Slip the backing plate over the screw heads at the keyhole slots and align with the gasket; tighten the two screws until snug (do not over-tighten).

Mount the weatherproof cover to the backing plate as shown in Fig. 32. Remove two slot fillers in the bottom of the cover to permit service tool cords to exit the cover. Check for full closing and latching.

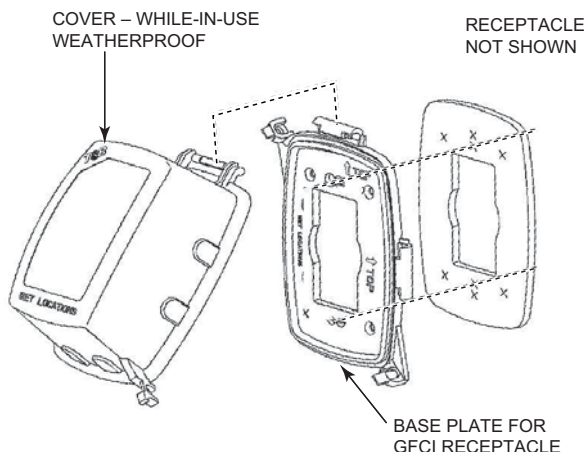

C09022

**Fig. 32 - Weatherproof Cover Installation**

**Non-unit powered type:** This type requires the field installation of a general-purpose 125-volt 15-A circuit powered from a source elsewhere in the building. Observe national and local codes when selecting wire size, fuse or breaker requirements and disconnect switch size and location. Route 125-v power supply conductors into the bottom of the utility box containing the duplex receptacle.

**Unit-powered type:** A unit-mounted transformer is factory-installed to stepdown the main power supply voltage to the unit to 115-v at the duplex receptacle. This option also includes a manual switch with fuse, located in a utility box and mounted on a bracket behind the convenience outlet; access is through the unit's control box access panel. See Fig. 31.

The primary leads to the convenience outlet transformer are not factory-connected. If local codes permit, the transformer primary leads can be connected at the line-side terminals on the unit-mounted non-fused disconnect switch; this will provide service power to the unit when the unit disconnect switch is open. See Fig. 33.

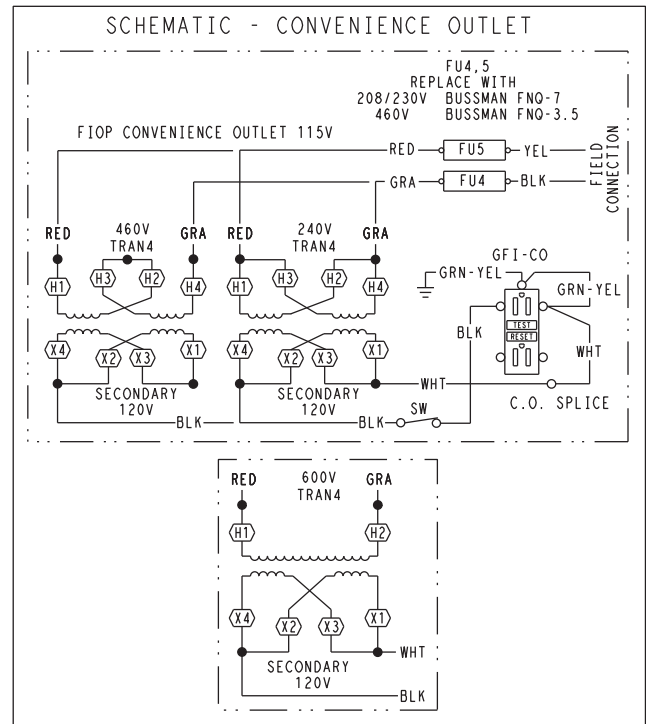

C10730

UNIT VOLTAGE	CONNECT AS	PRIMARY CONNECTIONS	TRANSFORMER TERMINALS
208, 230	240	L1: RED + YEL L2: BLU + GRA	H1 + H3 H2 + H4
460	480	L1: RED Splice BLU + YEL L2: GRA	H1 H2 + H3 H4
575	600	L1: RED L2: GRA	H1 H2

**Fig. 33 - Powered Convenience Outlet Wiring**

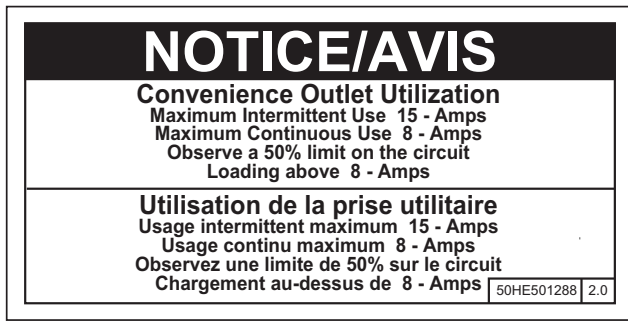

**Fig. 34 - Convenience Outlet Utilization Notice**

C10077

Test the GFCI receptacle by pressing the TEST button on the face of the receptacle to trip and open the receptacle. Check for proper grounding wires and power line phasing if the GFCI receptacle does not trip as required. Press the RESET button to clear the tripped condition.

Using unit-mounted convenience outlets: Units with unit-mounted convenience outlet circuits will often require that two disconnects be opened to de-energize all power to the unit. Treat all units as electrically energized until the convenience outlet power is also checked and de-energization is confirmed. Observe National Electrical Code Article 210, Branch Circuits, for use of convenience outlets.

**HACR —**

The amp rating of the HACR factory-installed option is based on the size, voltage, indoor motor and other electrical options of the unit as shipped from the factory. If field-installed accessories are added or changed in the field (i.e., electric heat, power exhaust), the HACR may no longer be of the proper amp rating and therefore will need to be removed from the unit. See unit nameplate and label on factory-installed HACR for the amp rating of the HACR that was shipped with the unit from the factory. See unit nameplates for the proper fuse, HACR or maximum over-current protection device required on the unit with field-installed accessories.

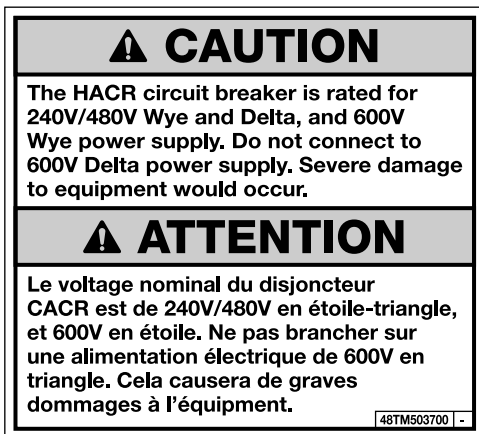

**Fig. 35 - HACR Caution Label**

C12105

**Factory-Option Thru-Base Connections —**

All units are equipped with the ability to bring utilities through the base.

The electrical entrance is located in the control box area can can be accessed through the control box access panel. An embossed area is provided with three knock outs. High voltage is brought through the multi knock out by removing the appropriate size for the size of the fitting required. A 7/8-in. knock out is provided for low voltage. An additional 7/8-in. knock out is provided for a 115 volt line which is used when the unit is equipped with the non-unit powered convenience outlet option.

All required fittings are field supplied. Install fittings when access to both top and bottom of the base pan is available.

**Units without Thru-Base Connections —**

1. Install liquid tight conduit between disconnect and control box.
2. Pull correctly rated high voltage wires through the conduit.
3. Install power lines to terminal connections as shown in Fig. 30.

**Field Control Wiring —**

The 50LC size 14-26 units require an external temperature control device such as a thermostat (field-supplied).

**Thermostat —**

Install a Carrier-approved accessory thermostat according to installation instructions included with the accessory. For complete economizer function and 3 stage compressor operation select a three-stage cooling thermostat. If a 3-stage cooling thermostat is not available use a 2-stage cooling thermostat instead, but note that this will limit cooling to just 2 stages. When electric heat is installed in the 50LC size 14-26 units, the thermostat must be capable of energizing the G terminal (to energize the Indoor Fan Contactor) whenever there is a space call for heat (energizing the W1 terminal). The accessory thermostats listed on the unit price pages can provide this signal but they are not configured to enable this signal as shipped.

Locate the thermostat accessory on a solid wall in the conditioned space to sense average temperature in accordance with the thermostat installation instructions.

If the thermostat contains a logic circuit requiring 24-v power, use a thermostat cable or equivalent single leads of different colors with minimum of eight leads. If the thermostat does not require a 24-v source (no “C” connection required), use a thermostat cable or equivalent with minimum of seven leads. Check the thermostat installation instructions for additional features which might require additional conductors in the cable.

For wire runs up to 50 ft (15 m), use no. 18 AWG (American Wire Gage) insulated wire (35°C minimum). For 50 to 75 ft (15 to 23 m), use no. 16 AWG insulated wire (35°C minimum). For over 75 ft (23 m), use no. 14 AWG insulated wire (35°C minimum). All wire sizes larger than no. 18 AWG cannot be directly connected to the thermostat and will require a junction box and splice at the thermostat.



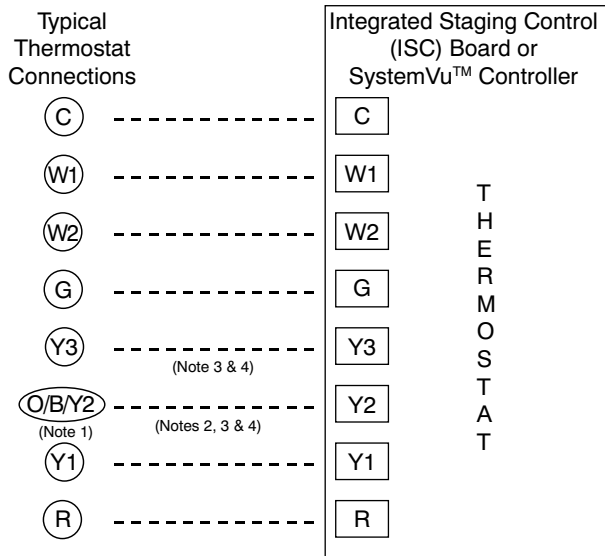

- Note 1: Typical multi-function marking. Follow manufacturer's configuration Instructions to select Y2.
- Note 2: Y2 to Y3 connection required for 2-stage cooling operation and when integrated economizer function is desired.
- Note 3: To Connect a 2-Stage Thermostat: Y2 to Y3 connection required for 2-stage cooling operation which provides low and high cooling states.
- Note 4: SystemVu controller is default configured for 3-stage cooling and 2-stage heating thermostats; it can be configured for other thermostat types.
- Field Wiring

a48-9346

**Fig. 36 - Typical Low-Voltage Control Connections**

**Unit without Thru-Base Connection Kit —**

Correctly rated low voltage wire can be routed through the rubber grommet located on the corner post adjacent to the control box access panel. Route wire through the grommet and then route the wire behind the corner post utilizing the factory provided wire ties secured to the control box. This will ensure separation of the field low voltage wire and the high voltage circuit. Route the low voltage wire to the Integrated Staging Control (ISC) board. See Fig. 37.

**NOTE:** If utilizing the through the base connections, route the low voltage wire through the wire ties to the ISC board.

**Configure for Electric Heat:** To configure the factory-approved thermostat, open the Advanced Setup menu, scroll down to ELECTRIC HEAT and change RANGE value from OFF to ON. Consult the thermostat installation instructions for full details.

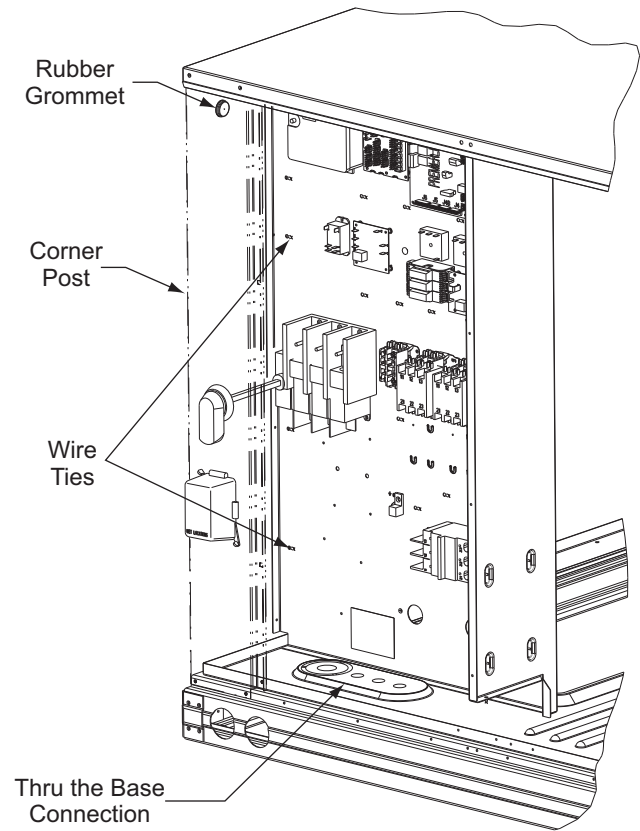

C10734

**Fig. 37 - Field Control Wiring Raceway**

**Heat Anticipator Settings —**

Set heat anticipator settings at 0.14 amp for the first stage and 0.14 amp for second-stage heating.

**Transformer Connection for 208-v Power Supply —**

All units except 208/230-v units are factory wired for the voltage shown on the nameplate. *If the 208/230-v unit is to be connected to a 208-v power supply, the control transformer must be rewired by moving the black wire with the 1/4-in. female spade connector from the 230-v connection and moving it to the 208-v 1/4-in. male terminal on the primary side of the transformer. Refer to unit label diagram for additional information.*

## Electric Heaters

50LC units may be equipped with factory or field-installed electric heaters. The heaters are modular in design.

Heater modules are installed in the compartment below the indoor blower access panel. Access is through the electric heat access panel. Heater modules slide into the compartment on tracks along the bottom of the heater opening. See Fig. 38, Fig. 39 and Fig. 40. Refer to the Electric Heater Kit Installation Instructions for complete details on field-installed electric heat accessory.

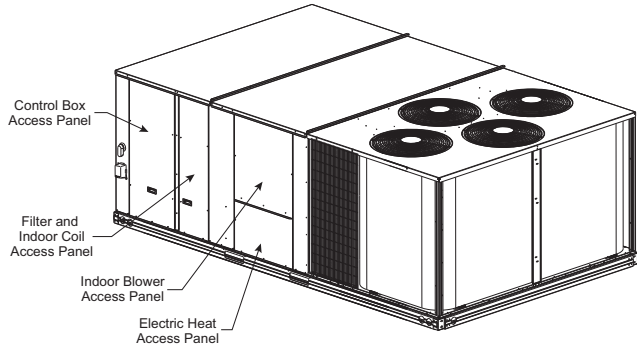

C10631

**Fig. 38 - Typical Access Panel Location**

Not all available heater modules may be used in every unit. Use only those heater modules that are ETL listed for use in a specific size unit. Refer to the label on the unit cabinet for the list of approved heaters.

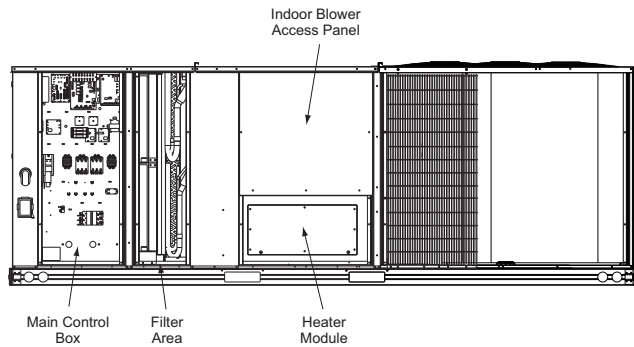

C10632

**Fig. 39 - Typical Component Location**

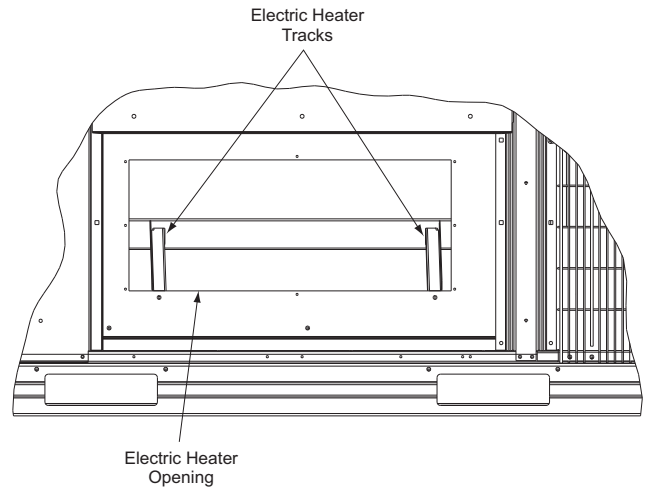

C09142

**Fig. 40 - Electric Heater Compartment (Cover Removed)**

### Low-Voltage Control Connections —

Locate the plug assembly in the electric heater section of the main unit. Connect the plug with the mating low voltage plug located on the heater. Note that the plug will already be connected when there is factory-installed electric heat (see Fig. 41).

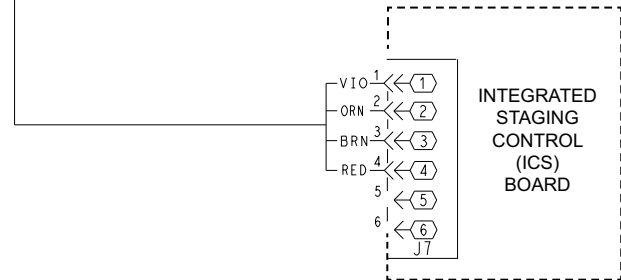
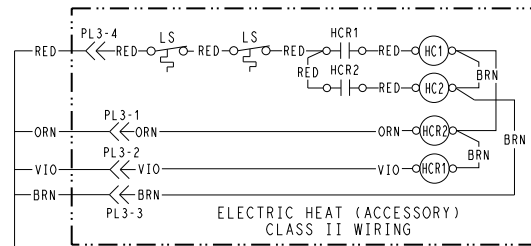

C13238

**Fig. 41 - Optional or Accessory Electric Heater Control Connections**

## Humidi-MiZer® System Control Connections

**NOTE:** It is suggested to ensure the Auto-Changeover function of an installed thermostat is enabled when used in conjunction with the Humidi-MiZer Adaptive Dehumidification system.

### Humidi-MiZer System – Space RH Controller —

The Humidi-MiZer dehumidification system requires a field-supplied and installed space relative humidity control device. This device may be a separate humidistat control (contact closes on rise in space RH above control setpoint) or a combination thermostat-humidistat control device with isolated contact set for dehumidification control. The humidistat is normally used in applications where a temperature control is already provided (units with RTU Open control), or a ZS series sensor with humidity sensing. SystemVu™ controls requires a Space Humidistat (HL38MG029) or a Wall Mount Space Humidity Sensor (33ZCSENSRH-01) or a Duct Mount Humidity Sensor (33ZCSENDRH-01).

#### To connect the Carrier humidistat (HL38MG029):

1. Route the humidistat 2-conductor cable (field-supplied) through the hole provided in the unit corner post.
2. Feed wires through the raceway built into the corner post (see Fig. 37) to the 24-v barrier located on the left side of the control box. The raceway provides the ETL-required clearance between high-voltage and low-voltage wiring.
3. Use wire nuts to connect humidistat cable to two PINK leads in the low-voltage wiring as shown in Fig. 43.

**NOTE:** 50LC\*\*14 - 26 units require a 3-stage cooling thermostat device and are not compatible with Carrier's Edge® Pro thermidstat.

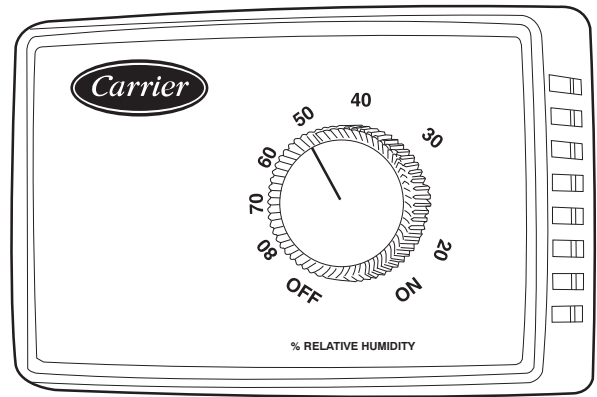

C09295

Fig. 42 - Accessory Field-Installed Humidistat

### RTU Open Controller (Factory-Installed Option)

For details on operating 50LC\*\*14-26 units equipped with the factory-installed RTU Open option refer to *48/50LC 07-26 Factory Installed Option RTU Open Multi-Protocol Controller Controls, Start-up, Operation and Troubleshooting* manual.

### SystemVu Controller (Factory-Installed Option)

For details on operating 50LC\*\*14-26 units equipped with the factory-installed SystemVu control option refer → to *48/50LC 04-26 Single Package Rooftop Units with SystemVu Controls Version 2.X Controls, Start-up, Operation and Troubleshooting* manual.

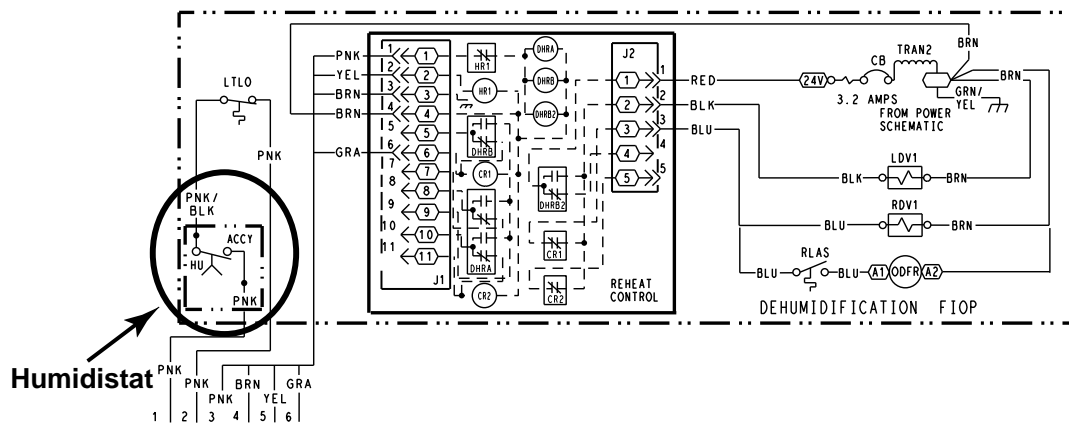

Fig. 43 - Typical Humidi-MiZer Adaptive Dehumidification System Humidistat Wiring

C14113

## Integrated Staging Control (ISC) Board

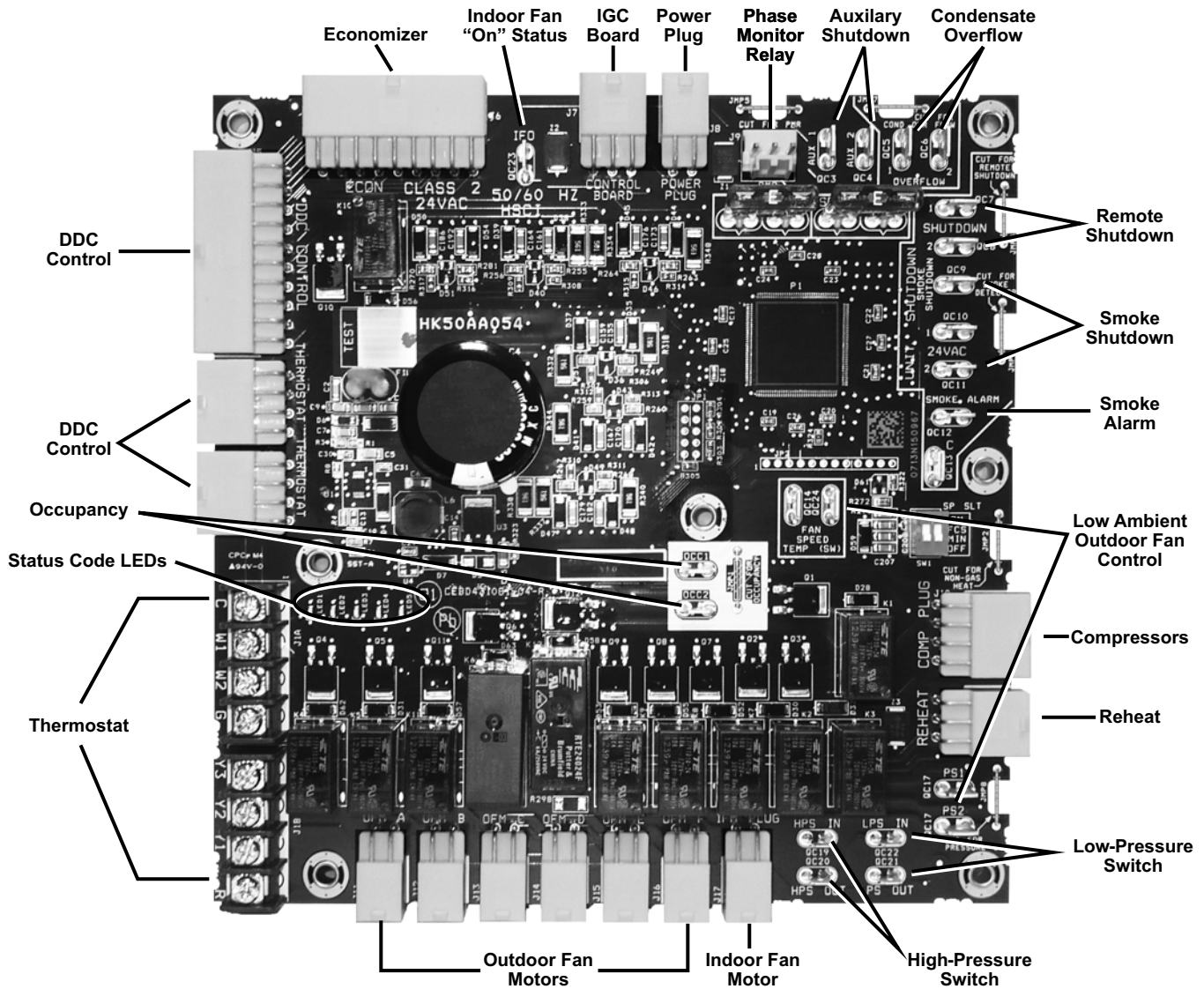

Fig. 44 - Integrated Staging Control (ISC) Board

a48-9321

### ISC Board - Sequence of Operation

#### General —

The Carrier Integrated Staging Control (ISC) is intended for use with a standard thermostat or direct digital controls (DDC) capable of three cooling stages. After initial power to the board, a Green LED will blink with a 1 second duty cycle indicating the unit is running properly. In the event of the ISC board failing, the Green LED will be OFF or continuously ON. When the unit is not running properly, the Green LED will blink along with Red LED lights. The Red LED light configuration will indicate the type of error the board has identified. See Fig. 44 for LED locations and Table 2 for a list of status codes.

The ISC board can be remotely shutdown by removing Jumper 4 and wiring to the Remote Shutdown terminal. The Smoke Control Module can shutdown the unit by removing Jumper 3 and wiring to the Smoke Shutdown terminal. The Smoke Alarm terminal on the ISC Board

provides a pass thru connection should a smoke alarm signal be connected. In the case of the RTU Open option, the RTU Open controller provides the signal which is passed thru the ISC board to the Smoke Alarm terminal.

The crankcase heater will run at all times except when the compressors are running. An auxiliary power supply (24Vac) available at TB-4 Terminal is provided to power auxiliary equipment. An optional Phase Monitor Relay can be wired to the PMR terminal by removing Jumper 5. An optional Condensate Flow Switch can be wired to the COFS Terminal by removing Jumper 7.

#### Ventilation —

In the Ventilation/Fan Mode (G on the thermostat), the indoor-fan will run at low speed and the damper will operate at minimum position.

**Table 2 – Status Code Descriptions for ISC Board LEDs**

ERROR#	ERROR NAME	LED INDICATION					
		LED01	LED02	LED03	LED04	LED05	
1	Check Smoke Detector/PMR/AUX		RED	Blinking Green LED (Note 1)			
2	Check HPS/LPS/COFS	RED	RED				
3	Call for Y3 with no call for Y1. Check Y1 wiring.					RED	
4	Call for Y3 with no call for Y1/Y2. Check Y1 wiring.					RED	RED
5	Call for Y2 with no call for Y1. Check Y1 wiring.		RED			RED	
6	Call for W2 with no call for W1. Check W1 wiring.	RED					RED
7	Call for heat (W1/W2) and cooling (Y1/Y2/Y3). Check thermostat wiring.	RED	RED			RED	RED
8	Call for heat (W1/W2) with no G. Check G wiring.		RED			RED	RED
9	Call for cooling (Y1/Y2/Y3) with no G. Check G wiring	RED	RED			RED	
10	Call for heat (W1/W2) and cooling (Y1/Y2/Y3) with no G. Check thermostat and G wiring.	RED	RED				RED
11	Check ISC Board and the thermostat wiring	RED				RED	RED
12	Check ISC Board and the thermostat wiring	RED					
13	Check ISC Board and the thermostat wiring	RED				RED	
14	Check ISC Board and the thermostat wiring						RED
15	Check ISC Board and the thermostat wiring		RED				RED

- NOTES: 1. Green LED Blinking at 1HZ indicates normal operation.  
 2. Solid red LED indicates an error exists, see above LED configuration.

**Cooling —**

In the Cooling Mode, the small and large compressors will be sequenced to maintain the thermostat temperature setpoint. The chart below shows the cooling operation based on the following conditions.

INPUT	OUTPUT			
Thermostat	Compressor C1	Compressor C2	Indoor Fan Speed	Outdoor Fan Speed
First Stage Cooling (Y1)	On	Off	Low	Low (700 rpm)
Second Stage Cooling (Y2)	Off	On	Medium	Medium (800 rpm)
Third Stage Cooling (Y3)	On	On	High	High (1000 rpm)

The outdoor fan and VFD controlled indoor-fan will operate at low, medium and high speed. The RPM is factory set by the CFM and static pressure requirements for the unit installed.

**Humidi-MiZer® System (Optional) —**

In the Dehumidification Mode, both compressors will run and Indoor airflow will be rise to High Speed.

At subcooler reheating mode (reheat-1), during part load conditions when the room temperature and humidity are above the set point, the unit initiates the sub-cooling mode of operation; a call for cooling and dehumidification. RDV (Reheat Discharge Valve) and TWV (Three Way Valve) close; Indoor and Outdoor airflow will rise until reaching 100% of Speed.

At hot-gas-bypass reheating mode (reheat-2), when there is a call for dehumidification without a call for cooling, a portion of the hot gas from the compressor bypasses the condenser coil when RDV opens and hot gas is fed into the liquid line, TWV closes in this mode and the system provides mainly latent cooling. Indoor airflow will rise until reaching 100% of Speed, Outdoor airflow will run at

High speed as long as outdoor temperature is above 80°F (26.7°C); when operating in this mode below 80°F (26.7°C) OAT, the system outdoor fan will operate as shown in the table below based on Size:

LC Size	RPM	Number of Fans On	Number of Fans Off
14	250	3	0
17	250	4	0
20	160	4	0
24	250	6	0
26	250	6	0

**Economizer (Optional) —**

When the economizer is in Free Cooling Mode and a demand for cooling exists (Y1 on the thermostat), the economizer will modulate the outdoor-air damper to provide a 50°F (10°C) to 55°F (13°C) mixed-air temperature into the zone and run the indoor-fan at high speed. As mixed-air temperature fluctuates above 55 °F (13°C) or below 50°F (10°C) dampers will be modulated (open or close) to bring the mixed-air temperature back within control. Upon more call for cooling (Y2 on the thermostat), the outdoor-air damper will maintain its current position, compressor C1 will run and the outdoor-fan will run at low speed. If there is further demand for cooling, the outdoor-air damper will maintain its current position, compressor C2 will run and the outdoor-fan will run at medium speed. The VFD controlled indoor-fan will operate at high speed regardless of the cooling demand.

If the increase in cooling capacity causes the mixed-air temperature to drop below 45°F (7°C), the outdoor-air damper will return to the minimum position. If the mixed-air temperature continues to fall, the outdoor-air damper will close. Control returns to normal once the mixed-air temperature rises above 48°F (9°C). The power exhaust fans will be energized and de-energized, if installed, as the outdoor-air damper opens and closes.

In field-installed accessory CO<sub>2</sub> sensors are connected to the Economizer, a demand controlled ventilation strategy will begin to operate. As the CO<sub>2</sub> level in the zone increases above the CO<sub>2</sub> set-point, the minimum position of the damper will be increased proportionally. As the CO<sub>2</sub> level decreases because of the increase of fresh air, the outdoor-air damper will be proportionally closed. For economizer operation, there must be a thermostat call for the fan (G). If the unit is occupied and the fan is on, the damper will operate at minimum position. Otherwise, the damper will be closed.

**Low Ambient Cooling Operation Down to 40°F (4°C)—**

In Low Ambient RTU conditions when the temperature is between 55°F (13°C) and 40°F (4°C), the Low Ambient Switch (LAS) will be active and the outdoor fans will run to the pre-set factory outdoor-fan speed. When the temperature is greater than 65°F (18°C), the Low Ambient Switch will deactivate and the outdoor fans will run in the standard cooling mode. If the Outdoor Fan Select Switch (see Fig. 45) is in the ON position, the outdoor fans will run in the Fan Cycle Speed Mode (FCS) set to 250 rpm. If the Outdoor Fan Select Switch is in the OFF position, the outdoor fans will run in the Minimum Fan Speed Mode (MIN) set to 160 rpm regardless of the cooling demand.

LC Size 14 through 26 units have a SPST normally open Low Ambient Switch wired across the TS and OF terminal and a jumper placed across the PS terminal (see Fig. 46). When the LAS is active, the switch will close making contact to the OF terminal. This is done for units that require all outdoor fans to run at the same pre-set factory Low Ambient Speed.

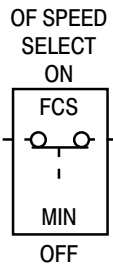

a48-9341

**Fig. 45 - Outdoor Fan Speed Select Switch**

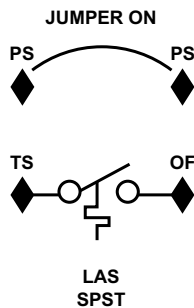

C13328

**Fig. 46 - Schematic of SPST Low Ambient Switch**

The Low Ambient Temperature Outdoor Fan Control Table (below) shows the operation of the outdoor fan for each unit.

**Table 3 – Low Ambient Temperature Outdoor Fan Control**

LC Size	No. of Fans On	No. of Fans Off	Switch	Outdoor Fan Select Switch	RPM
14	3	0	SPST	Up	250
17	4	0	SPST	Up	250
20	4	0	SPST	Up	250
24	6	0	SPST	Up	250
26	6	0	SPST	Up	250

**Heating —**

In the Heating Mode (W1 on the thermostat), power is applied to the G and W1 terminal at the ISC board and energizes the first state of electric heat. Upon more call for heat (W2 at the thermostat), power is applied to the G and W2 terminal at the ISC board and energizes the second state of electric heat. The VFD controlled indoor fan will operate at high speed regardless of the heating demand.

**EconoMi\$er® X (Factory-Installed Option)**

EconoMi\$er X is an economizer system which is available for 50LC 14-26 units.

The factory-installed option consists of:

- Either a Low leak or a Standard leak economizer damper assembly
- Direct-drive damper actuator with local equipment bus communications
- W7220 economizer controller with keypad and display
- Supply Air Temperature sensor (20K ohm)
- Outdoor changeover condition sensor (either 20K ohm dry-bulb or enthalpy sensor)

**Unit Installation —**

All damper hardware and standard economizer control components except the enthalpy sensor are factory-mounted in their operating location. Complete the unit installation by relocating the enthalpy sensor (when provided; see below), then assembling and mounting the unit’s outside air hood. Refer to the base unit’s installation instruction manual for directions on locating the hood parts package and assembling the hood with filters.

**Enthalpy Sensor Relocation —**

See Fig. 55 for view of the enthalpy sensor. Locate the enthalpy sensor on the side of the economizer housing; remove mounting screws and save screws. Confirm the DIP switches are set at OFF, OFF, OFF (see Table 11). Move the enthalpy sensor to the front face of the economizer housing and mount per label.

**W7220 Economizer Controller**

The economizer controller used on electro mechanical units is the Honeywell W7220.

The W7220 provides typical economizer functions, including:

- Management of outside air damper for base unit Occupied (damper open and modulating) and unit OFF or Unoccupied status (damper closed)

- Free-cooling using all outside air when outdoor conditions permit Integrated cooling operation using outside air and mechanical cooling when required
- Demand Controlled Ventilation (DCV) for modulating ventilation airflow according to space CO<sub>2</sub> level (requires factory-option or field-installed CO<sub>2</sub> sensor)

The W7220 control also includes a new capability that will adjust the damper control points during DCV or minimum ventilation operation as the indoor fan speed is changed. This control function ensures that required space ventilation airflow quantities are maintained during reduced fan speed operation.

Additional control capabilities include automatic detection of new sensors and detection of sensor failure or loss of communication.

The W7220 control module includes an integral user interface with keypad and LCD display that permits direct input of setpoint values and configurations and display of status and alarms.

The W7220 controller is located in the RTU base unit's Control Box. See the Installation Instructions for this base unit for the location of the Control Box access panel.

### User Interface —

The user interface consists of a 2-line LCD display and a 4-button keypad on the front of the economizer controller.

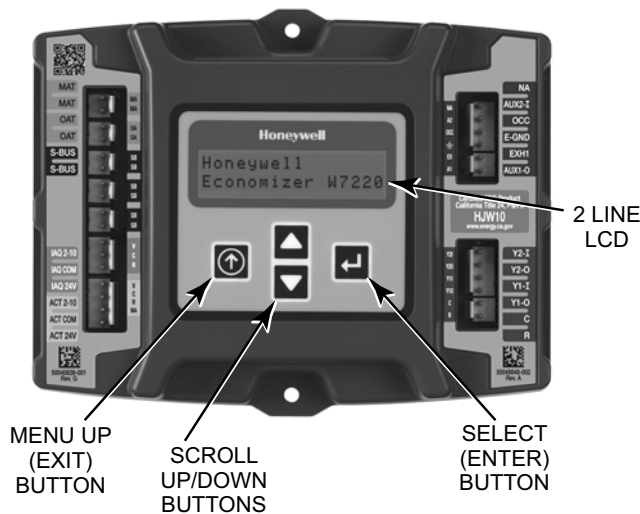

Fig. 47 - W7220 Controller

### Keypad

The four navigation buttons (see Fig. 47) are used to scroll through the menus and menu items, select menu items, and to change parameter and configuration settings.

### Using the Keypad with Menus

To use the keypad when working with menus:

- Press the ▲ (Up arrow) button to move to the previous menu.
- Press the ▼ (Down arrow) button to move to the next menu.

- Press the ↵ (Enter) button to display the first item in the currently displayed menu.
- Press the ⏴ (Menu Up/Exit) button to exit a menu's item and return to the list of menus.

The Menus in display order are:

- STATUS
- SETPOINTS
- SYSTEM SETUP
- ADVANCED SETUP
- CHECKOUT
- ALARMS

### Using the Keypad with Settings and Parameters

To use the keypad when working with Setpoints, System and Advanced Settings, Checkout tests and Alarms:

1. Navigate to the desired menu.
  2. Press the ↵ (Enter) button to display the first item in the currently displayed menu.
  3. Use the ▲ and ▼ buttons to scroll to the desired parameter.
  4. Press the ↵ (Enter) button to display the value of the currently displayed item.
  5. Press the ▲ button to increase (change) the displayed parameter value.
  6. Press the ▼ button to decrease (change) the displayed parameter value.
- NOTE:** When values are displayed, pressing and holding the ▲ or ▼ button causes the display to automatically increment.
7. Press the ↵ (Enter) button to accept the displayed value and store it in nonvolatile RAM.
  8. "CHANGE STORED" displays.
  9. Press the ↵ (Enter) button to return to the current menu parameter.
  10. Press the ⏴ (Menu Up/Exit) button to return to the previous menu.

### Menu Structure

**IMPORTANT:** Table 4 illustrates the complete hierarchy. Your menu parameters may be different depending on your configuration. For example if you do not have a DCV (CO<sub>2</sub>) sensor, then none of the DCV parameters appear.

The menu hierarchy has been modified to reflect controller configuration for 2-speed indoor fan application in the Staged Air Volume option.

**NOTE:** Some parameters in the menu use the letters MA or MAT, indicating a mixed air temperature sensor location before the cooling coil. This unit application has the control sensor located after the cooling coil, in the fan section, where it is designated as (Cooling) Supply Air Temperature or SAT sensor.

**Table 4 – Menu Structure\***

Menu	Parameter	Parameter Default Value	Parameter Range and Increment†	EXPANDED PARAMETER NAME Notes
STATUS	ECON AVAIL	NO	YES/NO	ECONOMIZING AVAILABLE YES = economizing available; the system can use outside air for free cooling when required
	ECONOMIZING	NO	YES/NO	ECONOMIZING ACTIVE YES = Outside air being used for Cooling Stage 1. NO = Economizing not active
	OCCUPIED	NO	YES/NO	OCCUPIED YES = OCC signal received from space thermostat or unitary controller. YES = 24 Vac on terminal OCC. NO = 0 Vac on terminal OCC.
	HEAT PUMP	n/a**	COOL HEAT	HEAT PUMP MODE (Not available on 2-Speed configuration)
	COOL Y1 –IN	OFF	ON/OFF	FIRST STAGE COOLING DEMAND (Y1 –IN) Y1 –I signal from space thermostat or unitary controller for Cooling Stage 1. ON = 24 Vac on terminal Y1 –I OFF = 0Vac on terminal Y1 –I
	COOL Y1 –OUT	OFF	ON/OFF	FIRST STAGE COOLING RELAY OUTPUT ON = 24 Vac on terminal Y1 –O; Stage 1 mechanical cooling called on OFF = 0 Vac on terminal Y1 –O; no mechanical cooling
	COOL Y2 –IN	OFF	ON/OFF	SECOND STAGE COOLING DEMAND (Y2 –IN) Y2 –I signal from space thermostat or unitary controller for Cooling Stage 2. ON = 24 Vac on terminal Y2 –I OFF = 0 Vac on terminal Y2 –I
	COOL Y2 –OUT	OFF	ON/OFF	SECOND STAGE COOLING RELAY OUTPUT ON = 24 Vac on terminal Y2 –O; Stage 2 mechanical cooling called on OFF = 0 Vac on terminal Y2 –O; no Stage 2 mechanical cooling
	MA TEMP	nn°F (or °C)	0 to 140°F (–18 to 60°C)	SUPPLY AIR TEMPERATURE, Cooling Mode Displays value of measured mixed/cooled air from SAT sensor in fan section. Displays --,– if not connected, short or out–of–range. See Menu Note 2
	DA TEMP	nn°F (or °C)	0 to 140°F (–18 to 60°C)	DISCHARGE AIR TEMPERATURE, after Heating section (Accessory sensor required) Displays when Discharge Air sensor is connected and displays measured discharge temperature. Displays --- --- --- if sensor sends invalid value, if not connected, short or out–of–range.
	OA TEMP	nn°F (or °C)	–40 to 140°F (–40 to 60°C)	OUTSIDE AIR TEMPERATURE Displays measured value of outdoor air temperature. Displays --- --- --- if sensor sends invalid value, if not connected, short or out–of–range.
	OA HUM	nn%	0 to 100%	OUTSIDE AIR RELATIVE HUMIDITY Displays measured value of outdoor humidity from OA enthalpy sensor.
	RA TEMP	nn°F (or °C)	0 to 140°F (–18 to 60°C)	RETURN AIR TEMPERATURE (Accessory sensor required) Displays measured value of return air temperature from RAT sensor.
	RA HUM	nn%	0 to 100%	RETURN AIR RELATIVE HUMIDITY (Accessory enthalpy sensor required) Displays measured value of return air humidity from RA sensor.
	IN CO2	___ppm	0 to 2000 ppm	SPACE/RETURN AIR CO2 (CO2 sensor required, accessory or factory option) Displays value of measured CO2 from CO2 sensor. Invalid if not connected, short or out–of–range
	DCV STATUS	n/a	ON/OFF	DEMAND CONTROLLED VENTILATION STATUS (CO2 sensor required, accessory or factory option) Displays ON if IN CO2 value above setpoint DCV SET and OFF if below setpoint DCV SET.
	DAMPER OUT	2.0V	2.0 to 10.0V	Displays voltage output to the damper actuator. 0% = OSA Damper fully closed 100% = OSA Damper full open
	ACT POS	nn%	0 to 100%	Displays actual position of outdoor air damper actuator 2.0V = OSA Damper fully–closed 10.0V = OSA Damper full open
	ACT COUNT	n/a	1 to 65535	Displays number of times actuator has cycled. 1 Cycle equals accrued 180° of actuator movement in any direction
	ACTUATOR	n/a	OK/Alarm (on Alarm menu)	Displays Error if voltage or torque is below actuator range
EXH1 OUT	OFF	ON/OFF	EXHAUST STAGE 1 RELAY OUTPUT Output of EXH1 terminal: ON = relay closed OFF = relay open	



**Table 4 - Menu Structure\* (cont)**

Menu	Parameter	Parameter Default Value	Parameter Range and Increment†	EXPANDED PARAMETER NAME Notes
<b>STATUS (cont)</b>	EXH2 OUT	OFF	ON/OFF	EXHAUST STAGE 2 RELAY OUTPUT Output of AUX terminal; displays only if AUX = EXH2 ON = relay closed OFF = relay open
	MECH COOL ON	0	0, 1, or 2	Displays stage of mechanical cooling that is active.
	FAN SPEED	n/a	LOW or HIGH	SUPPLY FAN SPEED Displays speed setting of fan on a 2–speed fan unit.
	W (HEAT ON)	n/a	ON/OFF	HEAT DEMAND STATUS Displays status of heat demand on a 2–speed fan unit.
<b>SETPOINTS</b>	MAT SET	53°F (12°C)	38 to 65°F; (3 to 18°C) increment by 1	SUPPLY AIR SETPOINT Setpoint determines where the economizer will modulate the OA damper to maintain the mixed air temperature. See Menu Note 2.
	LOW T LOCK	32°F (0°C)	–45 to 80°F; (–43 to 27°C) increment by 1	COMPRESSOR LOW TEMPERATURE LOCKOUT Setpoint determines outdoor temperature when the mechanical cooling cannot be turned on.
	DRYBLB SET	63°F (17°C)	48 to 80°F (9 to 27°C) increment by 1	OA DRY BULB TEMPERATURE CHANGEOVER SETPOINT Setpoint determines where the economizer will assume outdoor air temperature is good for free cooling; e.g.: at 63°F (17°C), unit will economize at 62°F (16.7°C) and below and not economize at 64°F (17.8°C) and above. There is a 2°F (1.1°C) deadband. See Menu Note 3
	ENTH CURVE	ES3	ES1, ES2, ES3, ES4, or ES5	ENTHALPY CHANGEOVER CURVE (Requires enthalpy sensor option) Enthalpy boundary “curves” for economizing using single enthalpy.
	DCV SET	1100ppm	500 to 2000 ppm; increment by 100	DEMAND CONTROLLED VENTILATION SETPOINT Displays only if CO <sub>2</sub> sensor is connected. Setpoint for Demand Controlled Ventilation of space. Above the setpoint, the OA dampers will modulate open to bring in additional OA to maintain a space ppm level below the setpoint.
	MIN POS L	6.0 V	2 to 10 Vdc	VENTILATION MINIMUM POSITION AT LOW SPEED Displays ONLY if a CO <sub>2</sub> sensor is NOT connected.
	MIN POS H	4.4 V	2 to 10 Vdc	VENTILATION MINIMUM POSITION AT HIGH SPEED Displays ONLY if a CO <sub>2</sub> sensor is NOT connected.
	VENTMAX L	6.0 V	2 to 10 Vdc	DCV MAXIMUM DAMPER POSITION AT LOW SPEED (Requires CO <sub>2</sub> sensor connected)
	VENTMAX H	4.4 V	2 to 10 Vdc	DCV MAXIMUM DAMPER POSITION AT HIGH SPEED (Requires CO <sub>2</sub> sensor connected)
	VENTMIN L	3.7 V	2 to 10 Vdc	DCV MINIMUM DAMPER POSITION AT LOW SPEED (Requires CO <sub>2</sub> sensor connected)
	VENTMIN H	2.8 V	2 to 10 Vdc	DCV MINIMUM DAMPER POSITION AT HIGH SPEED (Requires CO <sub>2</sub> sensor connected)
	EXH1 L SET	65%	0 to 100%; Increment by 1	EXHAUST FAN STAGE 1 SETPOINT AT LOW SPEED Setpoint for OA damper position when exhaust fan1 is powered by the economizer
	EXH1 H SET	50%	0 to 100%; Increment by 1	EXHAUST FAN STAGE 1 SETPOINT AT HIGH SPEED Setpoint for OA damper position when exhaust fan1 is powered by the economizer
	EXH2 L SET	80%	0 to 100%; Increment by 1	EXHAUST FAN STAGE 2 SETPOINT AT LOW SPEED Setpoint for OA damper position when exhaust fan1 is powered by the economizer. Only used when AUX1 –O is set to EHX2.
	EXH2 H SET	75%	0 to 100%; Increment by 1	EXHAUST FAN STAGE 2 SETPOINT AT HIGH SPEED Setpoint for OA damper position when exhaust fan1 is powered by the economizer. Only used when AUX1 –O is set to EHX2.

**Table 4 - Menu Structure\* (cont)**

Menu	Parameter	Parameter Default Value	Parameter Range and Increment†	EXPANDED PARAMETER NAME Notes
<b>SYSTEM SETUP</b>	INSTALL	01/01/10		Display order = MM/DD/YY Setting order = DD, MM, then YY.
	UNITS DEG	°F	°F or °C	Sets economizer controller in degrees Fahrenheit or Celsius.
	EQUIPMENT	CONV	Conventional or HP	CONV = conventional; HP O/B = Enable Heat Pump mode. Not available with 2–speed See Menu Note 4
	AUX2 I	W	W required for 2–speed mode	W = Informs controller that system is in heating mode. SD = Enables configuration of shutdown (not available on 2–Speed) See Menu Note 4
	FAN TYPE	2speed	2speed required	Sets the economizer controller for operation of 1 speed or 2 speed indoor fan system. See Menu Note 4.
	FAN CFM	5000cfm	100 to 15000 cfm; increment by 100	UNIT DESIGN AIRFLOW (CFM) Enter ONLY of using DCVCAL ENA = AUTO The value is found in the Project Submittal documents for the specific RTU.
	AUX OUT	NONE	NONE EXH2 SYS	Select OUTPUT for AUX1 O relay NONE = not configured (output is not used) EXH2 = second damper position relay closure for second exhaust fan SYS = use output as an alarm signal
	OCC	INPUT	INPUT or ALWAYS	OCCUPIED MODE BY EXTERNAL SIGNAL When using a setback thermostat with occupancy out (24 Vac), the 24 Vac is input to the OCC terminal. RTU control circuit provides 24–Vac to OCC through OCCUPIED terminals on Integrated Staging Control. Board
	FACTORY DEFAULT	NO	NO or YES	Resets all set points to factory defaults when set to YES. LCD will briefly flash YES and change to NO but all parameters will change to the factory default values. <b>RECHECK AUX2 I and FANTYPE for required 2–speed values.</b>
<b>ADVANCED SETUP</b>	MA LO SET	45°F (7°C)	35 to 55°F; (2 to 12°C) Incremented by 1°	SUPPLY AIR TEMPERATURE LOW LIMIT Temperature to achieve Freeze Protection (close damper and alarm if temperature falls below setup value)
	FREEZE POS	CLO	CLO or MIN	FREEZE PROTECTION DAMPER POSITION Damper position when freeze protection is active CLO = closed MIN = MIN POS or VENTMAX
	CO2 ZERO	0ppm	0 to 500 ppm; Increment by 10	CO <sub>2</sub> ppm level to match CO <sub>2</sub> Sensor start level.
	CO2 SPAN	2000ppm	1000 to 3000 ppm; Increment by 50	CO <sub>2</sub> ppm span to match CO <sub>2</sub> sensor.
	STG3 DLY	2.0h	0 min, 5 min, 15 min, then 15 min intervals. Up to 4 h or OFF	COOLING STAGE 3 DELAY Delay after stage 2 for cool has been active. Turns on 2 <sup>nd</sup> stage of cooling when economizer is 1 <sup>st</sup> stage and mechanical cooling is 2 <sup>nd</sup>
	SD DMPR POS	CLO	CLO or OPN	Function NOT AVAILABLE with 2–speed mode
	DCVCAL ENA	MAN	MAN (manual)	Turns on the DCV automatic control of the dampers. Resets ventilation.
	MATTCAL	0.0°F (or C)	+/-2.5°F (+/-1.4°C)	SUPPLY AIR TEMPERATURE CALIBRATION Allows for the operator to adjust for an out of calibration supply air temperature (SAT) sensor
	OA T CAL	1.0°F (or C)	+/-2.5°F (+/-1.4°C)	OUTSIDE AIR TEMPERATURE CALIBRATION Allows for the operator to adjust for an out of calibration outside air temperature (OAT) sensor
	OA H CAL	0% RH	+/-10% RH	OUTSIDE AIR HUMIDITY CALIBRATION Allows for the operator to adjust for an out of outside air enthalpy sensor
	RA T CAL	2.0°F (or C)	+/-2.5°F (+/-1.4°C)	RETURN AIR TEMPERATURE CALIBRATION Allows for the operator to adjust for an out of calibration return air temperature (RA) sensor
	RA H CAL	0% RH	+/-10% RH	RETURN AIR HUMIDITY CALIBRATION Allows for the operator to adjust for an out of calibration return air enthalpy sensor
	DA T CAL	0.0°F (or C)	+/-2.5°F (+/-1.4°C)	DISCHARGE AIR TEMPERATURE CALIBRATION Allows for the operator to adjust for an out of calibration discharge air temperature (DAT) sensor
	2SP FAN DELAY	5 Minutes	0 to 20 minutes in 1 minute increments	TIME DELAY ON 2 <sup>nd</sup> STAGE ECONOMIZING While in the Economizing mode, this is the delay between thermostat Y2 call and Y1–O output to mechanical cooling stage, to allow high speed fan operation to attempt to cool space first.

**Table 4 - Menu Structure\* (cont)**

Menu	Parameter	Parameter Default Value	Parameter Range and Increment†	EXPANDED PARAMETER NAME Notes
CHECKOUT	DAMPER VMIN .HS	n/a	n/a	Positions OA damper to VMIN High Speed position
	DAMPER VMAX .HS	n/a	n/a	Positions OA damper to VMAX High Speed position
	DAMPER OPEN	n/a	n/a	Positions OA damper to the full open position.
	DAMPER CLOSE	n/a	n/a	Positions damper to the fully closed position
	CONNECT Y1 –O	n/a	n/a	Closes the Y1 –O relay (Y1 –O)
	CONNECT Y2 –O	n/a	n/a	Closes the Y2 –O relay (Y2 –O)
	CONNECT AUX1O	n/a	n/a	Energizes the AUX1O output. If Aux setting is: <ul style="list-style-type: none"> <li>• NONE – not action taken</li> <li>• ERV – 24 Vac out. Turns on or signals an ERV that the conditions are not good for economizing but are good for ERV operation.††</li> <li>• SYS – 24 Vac out. Issues a system alarm</li> </ul>
ALARMS( )				Alarms display only when they are active. The menu title “ALARMS( )” includes the number of active alarms in parenthesis ( ).
	MA T SENS ERR	n/a	n/a	SUPPLY AIR TEMPERATURE SENSOR ERROR
	CO2 SENS ERR	n/a	n/a	CO2 SENSOR ERROR
	OA T SENS ERR	n/a	n/a	OUTSIDE AIR TEMPERATURE SENSOR ERROR OAT sensor connected at input terminals OAT
	OA SYLK SENS ERR	n/a	n/a	OUTSIDE AIR TEMPERATURE SENSOR ERROR OAT sensor connected on S–bus
	DA T SENS ERR	n/a	n/a	DISCHARGE AIR TEMPERATURE SENSOR ERROR
	SYS ALARM	n/a	n/a	When AUX is set to SYS and there is any alarm (e.g., failed sensors, etc.), the AUX terminal has 24 Vac out.
	ACT UNDER V	n/a	n/a	ACTUATOR VOLTAGE LOW Voltage received at actuator is below expected range
	ACT OVER V	n/a	n/a	ACTUATOR VOLTAGE HIGH Voltage received at actuator is above expected range
	ACT STALLED	n/a	n/a	ACTUATOR STALLED Actuator stopped before reaching commanded position

\* Table 4 illustrates the complete hierarchy, your menu parameters may be different depending on your configuration. For example if you do not have a DCV (CO<sub>2</sub>) sensor, then none of the DCV parameters appear.

† When values are displayed, pressing and holding the ▲ or ▼ button causes the display to automatically increment.

\*\* n/a = not applicable

†† ERV Operation: When in Cooling mode AND the conditions are NOT OK for economizing – the ERV terminal will be energized. In the Heating mode the ERV terminal will be energized when the OA is below the ERV OAT setpoint in the setpoint menu.

**Menu Notes**

- 1 **STATUS –> OCCUPIED** – The factory-standard Occupancy signal originates with a thermostat or other controller call for indoor fan operation at ISC terminal G. This signal passes through the Integrated Staging Control Board’s OCCUPIED jumper JMP1 to the ECONO connector and to the W7220’s OCC input terminal. An external timeclock or relay is required to implement an Occupancy schedule on the economizer damper position.
- 2 **STATUS -> MA TEMP, SETPOINTS -> MAT SET** – The W7220 menu parameters and labels include designations MA, MAT and Mixed Air for the economizer cooling control sensor. On these rooftop units, the economizer control sensor is located downstream of the evaporator/indoor coil in the supply fan section where this sensor is designated as Supply Air Temperature (SAT) sensor.
- 3 **SETPOINTS -> DRYBLB SET** – This point is not displayed if a Return Air (differential) temperature sensor or an Outdoor Air enthalpy sensor is connected.
- 4 **SYSTEM SETUP** parameters must be configured as noted for 2-Speed unit operation:  
**EQUIPMENT** = CONV  
**AUX2 I** = W  
**FAN TYPE** = 2SPEED

## Connections and Applications

### W7220 Economizer Module Wiring —

Use Fig. 48 and Tables 5 and 6 to locate the wiring terminals for the Economizer module.

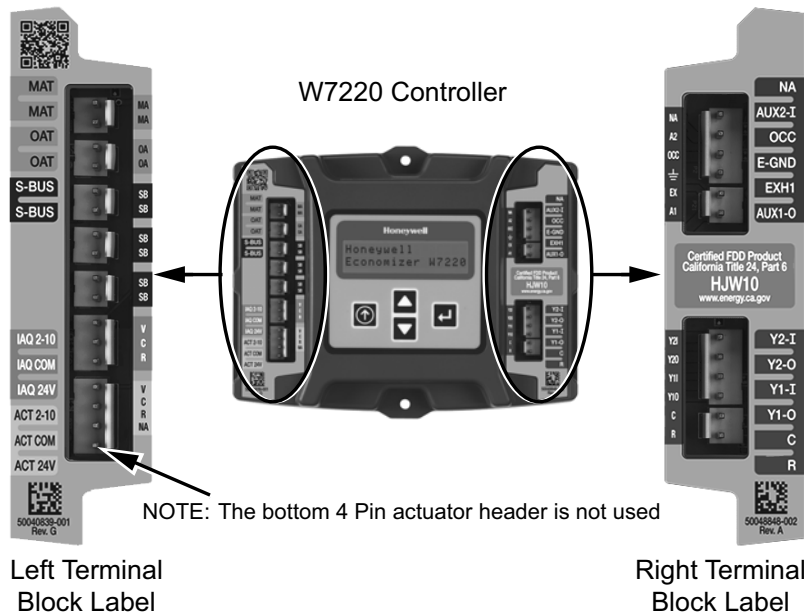

Fig. 48 - W7220 Economizer Module Terminal Connection Labels

C14156

Table 5 – Economizer Module - Left Hand Terminal Blocks

Label	Type	Description
<b>Top Left Terminal Block</b>		
MAT MAT	20k NTC and COM	Supply Air Temperature Sensor (polarity insensitive connection)
OAT OAT	20k NTC and COM	Outdoor Air Temperature Sensor (polarity insensitive connection)
S-BUS S-BUS	S-Bus (Sylk Bus)	Enthalpy Control Sensor (polarity insensitive connection)
<b>Bottom Left Terminal Block</b>		
IAQ 2-10	2-10 Vdc	Air Quality Sensor Input (e.g. CO <sub>2</sub> sensor)
IAQ COM	COM	Air Quality Sensor Common
IAQ 24V	24 Vac	Air Quality Sensor 24 Vac Source
ACT 2-10	2-10 Vdc	Damper Actuator Output (2-10 Vdc)
ACT COM	COM	Damper Actuator Output Common
ACT 24V	24 Vac	Damper Actuator 24 Vac Source

Table 6 – Economizer Module - Right Hand Terminal Blocks

Label	Type	Description
<b>Top Right Terminal Block</b>		
N/A	n/a	The first terminal is not used
AUX2-I	24 Vac IN	Input from Thermostat W1 indicating base unit is in Heat mode, damper controls to High Fan Speed setpoints
OCC	24 Vac IN	Occupied / Unoccupied Input
E-GND	E-GND	Earth Ground – System Required
EXH1	24 Vac OUT	Exhaust Fan 1 Output
AUX1-O	24 Vac OUT	Programmable: Exhaust fan 2 output or ERV or System Alarm output
<b>Bottom Right Terminal Block</b>		
Y2-I	24 Vac IN	Y2 in – Cooling Stage 2 Input from space thermostat
Y2-O	24 Vac OUT	Y2 out – Cooling Stage 2 Output to stage 2 mechanical cooling
Y1-I	24 Vac IN	Y1 in – Cooling Stage 2 Input from space thermostat
Y1-O	24 Vac OUT	Y1 out – Cooling Stage 2 Output to stage 2 mechanical cooling
C	COM	24 Vac Common
R	24 Vac	24 Vac Power (Hot)

Refer to Fig. 49 and 50 for sensor and controls connections.

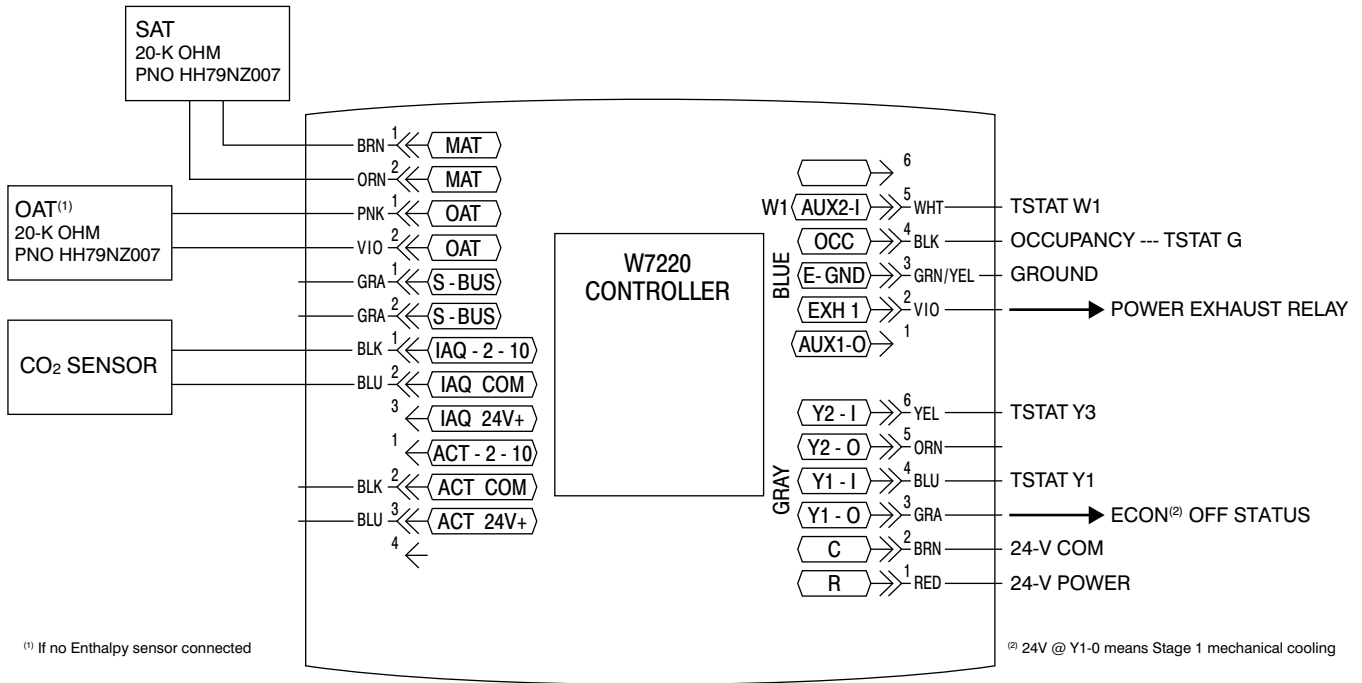

Fig. 49 - W7220 Sensor and Control I/O Connections

a48-9347

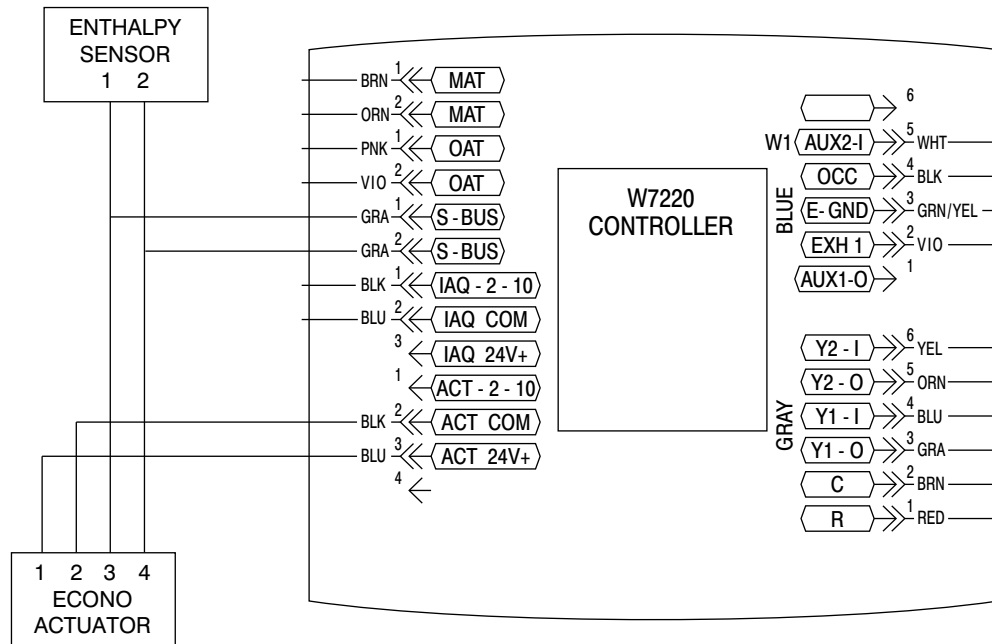

Fig. 50 - Actuator/S-BUS

a48-9348

## Economizer Control Configurations

### Enthalpy Changeover Control —

Economizer changeover based on outdoor air enthalpy requires an outdoor air enthalpy sensor to replace the OAT sensor. The enthalpy sensor is available as a factory-installed option or as a field-installed accessory (part number HH57AC081). See Fig. 1 for model number nomenclature; check Position #15 for codes R or S indicating a factory-installed enthalpy sensor. Use Fig. 51

and Table 7 to select the enthalpy changeover setting to enter in menu item SETPOINTS -> ENTH CURVE.

### Enthalpy Settings —

When the OA temperature, enthalpy and dew point are below the respective setpoints, the Outdoor Air can be used for economizing. Fig. 51 shows the new single enthalpy boundaries in the W7220. There are 5 boundaries (setpoints ES1 through ES5), which are defined by dry bulb temperature, enthalpy and dew point.

Refer to Table 7 for ENTH CURVE setpoint values.

The W7220 calculates the enthalpy and dew point using the OA temperature and humidity input from the OA enthalpy sensor. When the OA temperature, OA humidity and OA dew point are all below the selected boundary, the economizer sets the economizing mode to YES, economizing is available.

When all of the OA conditions are above the selected boundary, the conditions are not good to economize and the mode is set to NO.

Fig. 51 shows the 5 current boundaries. There is also a high limit boundary for differential enthalpy. The high limit boundary is ES1 when there are no stages of mechanical cooling energized and HL (high limit) when a compressor stage is energized.

Table 7 provides the values for each boundary limit.

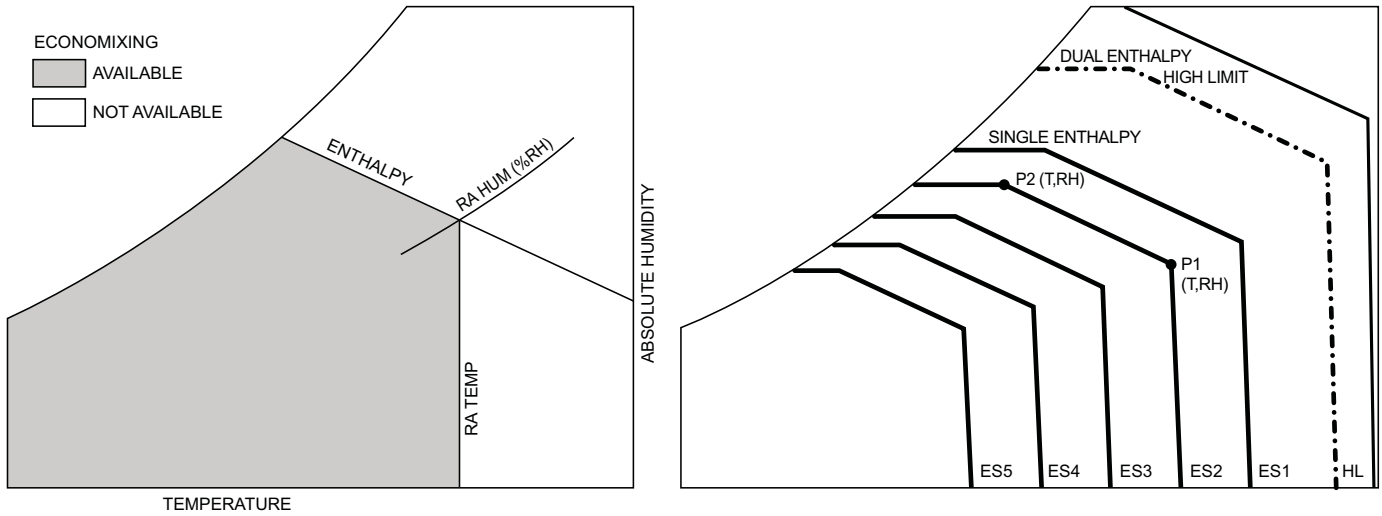

C12015

**Fig. 51 - Single Enthalpy Curve and Boundaries**

**Table 7 – Single Enthalpy and Dual Enthalpy High Limit Curves (EN Units)**

Enthalpy Curve	Temp. Dry-Bulb (°F)	Temp. Dewpoint (°F)	Enthalpy (btu/lb/da)	Point P1		Point P2	
				Temp. (°F)	Humidity %RH	Temp. (°F)	Humidity %RH
ES1	80.0	60.0	28.0	80.0	36.8	66.3	80.1
ES2	75.0	57.0	26.0	75.0	39.6	63.3	80.0
ES3	70.0	54.0	24.0	70.0	42.3	59.7	81.4
ES4	65.0	51.0	22.0	65.0	44.8	55.7	84.2
ES5	60.0	48.0	20.0	60.0	46.9	51.3	88.5
HL	86.0	66.0	32.4	86.0	38.9	72.4	80.3

**Demand Controlled Ventilation —**

Demand Controlled Ventilation (DCV) function requires a space air CO<sub>2</sub> sensor be connected to the W7220 controller. The CO<sub>2</sub> sensor provides a 2 to 10 vdc signal proportional to the space CO<sub>2</sub> level. This sensor is available as a factory-installed option (located in the unit's return air plenum) or as a field-installed accessory. See Fig. 1 for model number nomenclature; check Position #9 for codes E, F, G or H indicating a factory-installed CO<sub>2</sub> sensor. The W7220 automatically recognizes the connection of this sensor and self-enables the DCV function after the Configuration period.

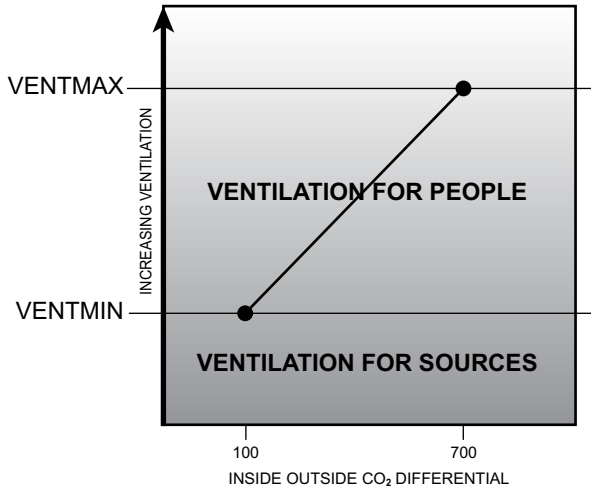

C12167

**Fig. 52 - DCV Single-Speed System Setpoints**

**DCV with Single-Speed Fan System:** During DCV, the outside air damper modulates between two user configurations depending upon the signal level of the space or return air CO<sub>2</sub> sensor representing the space occupancy level. The lower of these two positions is referred to as the Minimum IAQ Damper Position (designated VENTMIN) while the higher is referred to as Economizer Minimum Position (designated MINIMUM POSITION or VENTMAX). The VENTMIN position

should be set to an economizer position that brings in enough fresh air to remove contaminants and CO<sub>2</sub> generated by sources other than people; this airflow rate is designated Va. The VENTMAX should be set to an economizer position that brings in enough fresh air to remove contaminants and CO<sub>2</sub> generated by all sources including people at the design condition for maximum space occupancy; this airflow rate is designated Vbz.

**DCV with Two-Speed Fan System:** Ventilation codes require that the same ventilation rates (Vbz and Va, expressed as CFM) be provided regardless of supply fan speed. When the supply fan speed is reduced, the internal static pressure in the unit's return plenum also decreases. If the same outside air damper position is retained, the airflow rate through the OA damper decreases below the Va and Vbz levels. To restore ventilation rates to design levels, the damper positions VENTMIN and VENTMAX must be automatically adjusted when the fan speed changes. The W7220 provides this function when it is configured for 2-speed fan operation through a second set of damper position setpoints.

During operation at High fan speed, the damper setpoint limits are designated VENTMIN H and VENTMAX H. Damper operation is same as described under Single-Speed Fan above.

During operation at Low fan speed, the damper setpoint limits change to VENTMIN L and VENTMAX L. These settings are higher than the comparable High speed settings and cause the outside air damper to open more to allow the same Va and Vbz airflow rates to be admitted to the space.

Adjust the DCV setpoints VENTMAX H and VENTMAX L with supply fan speed in High speed and Low speed respectively to provide the design load ventilation airflow rate Vbz by measuring outside air temperature, return air temperature and supply air temperature. Make damper position adjustments with at least 10°F temperature difference between the outdoor and return-air temperatures.

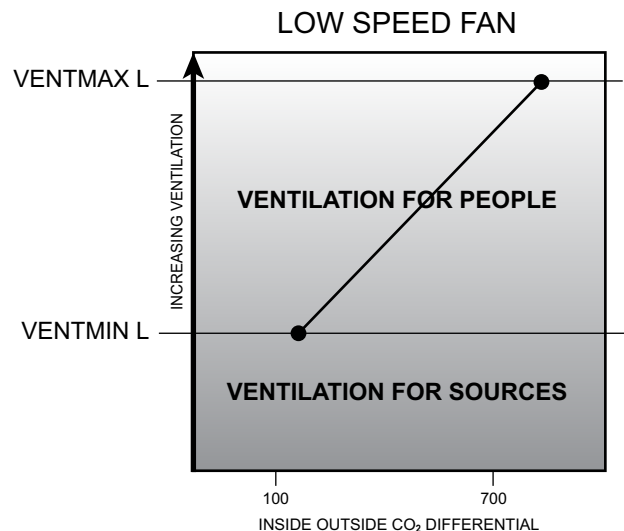
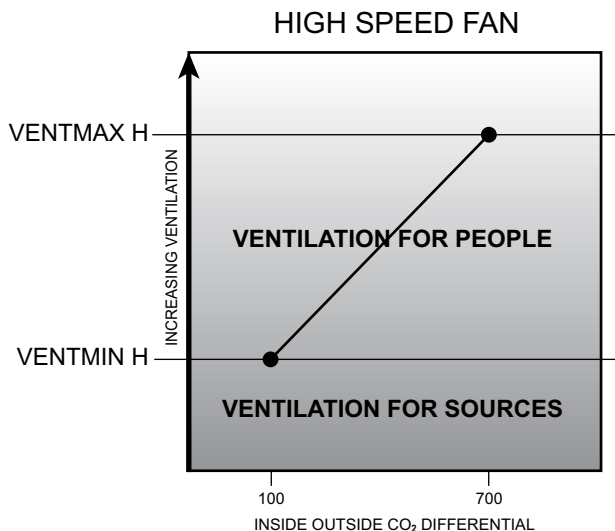

C12168

**Fig. 53 - DCV 2-Speed System Setpoints — Same Ventilation CFM at Both Speeds**

To determine the damper setpoint position, perform the following procedure for each condition setpoint, with mechanical cooling OFF:

Calculate the appropriate supply air temperature using the following formula:

$$TS = (TO \times Vbz/CFM) + TR \times (CFM - Vbz)/CFM$$

TS = Supply Air Temperature  
 TO = Outdoor Air Temperature  
 Vbz = Design Maximum Ventilation CFM  
 CFM= Unit Supply Airflow Rate  
 TR = Return Air Temperature

As an example:

Unit Airflow Rate at High Speed is 4000 CFM  
 Ventilation CFM at design occupancy Vbz is 1200 CFM  
 TO = 60 F  
 TR = 75 F

$$\begin{aligned} \text{Required TS} &= 60 \times (1200/4000) + 75 \times (4000 - 1200/4000) \\ &= 60 \times 0.30 + 75 \times 0.70 = 18.0 + 52.5 \\ &= 70.5 \end{aligned}$$

At the W7220 keypad, enter the parameter SETUP -> VENTMAX H and adjust the setpoint value until the observed Supply Air Temperature (MA TEMP) reaches 70.5. Press the ↵ “Enter” key to save this setpoint to controller memory.

When determining VENTMIN setpoints, substitute the value for Va in place of Vbz in the formula.

**DCV Setpoint:** The SETPOINTS parameter DCV SET defines the space CO<sub>2</sub> level above which the DCV mode begins to open the outside air damper beyond its VENTMIN ventilation lower limit. This setpoint should be a minimum of 100 ppm greater than the outdoor ambient CO<sub>2</sub> level to ensure the outside air will be capable of diluting the space CO<sub>2</sub> level. A typical value for outdoor CO<sub>2</sub> is 400 ppm; adjust the setpoint DCV SET to 500 ppm if outdoor CO<sub>2</sub> level is not known. The factory default value for DCV SET is 1100 ppm.

### Economizer Occupancy Control —

The 24-v signal that terminates at the W7220’s OCC input to place the economizer control in Occupied mode when the supply fan starts is routed through the rooftop unit’s Integrated Staging Control Board at its OCCUPANCY jumper. To implement an occupancy control for the economizer operation, connect a contact set at ISC OCCUPANCY quick-connect terminals and cut jumper JMP1. To allow automatic occupancy mode, close the control contacts. To place the economizer in Unoccupied mode, open the control contacts.

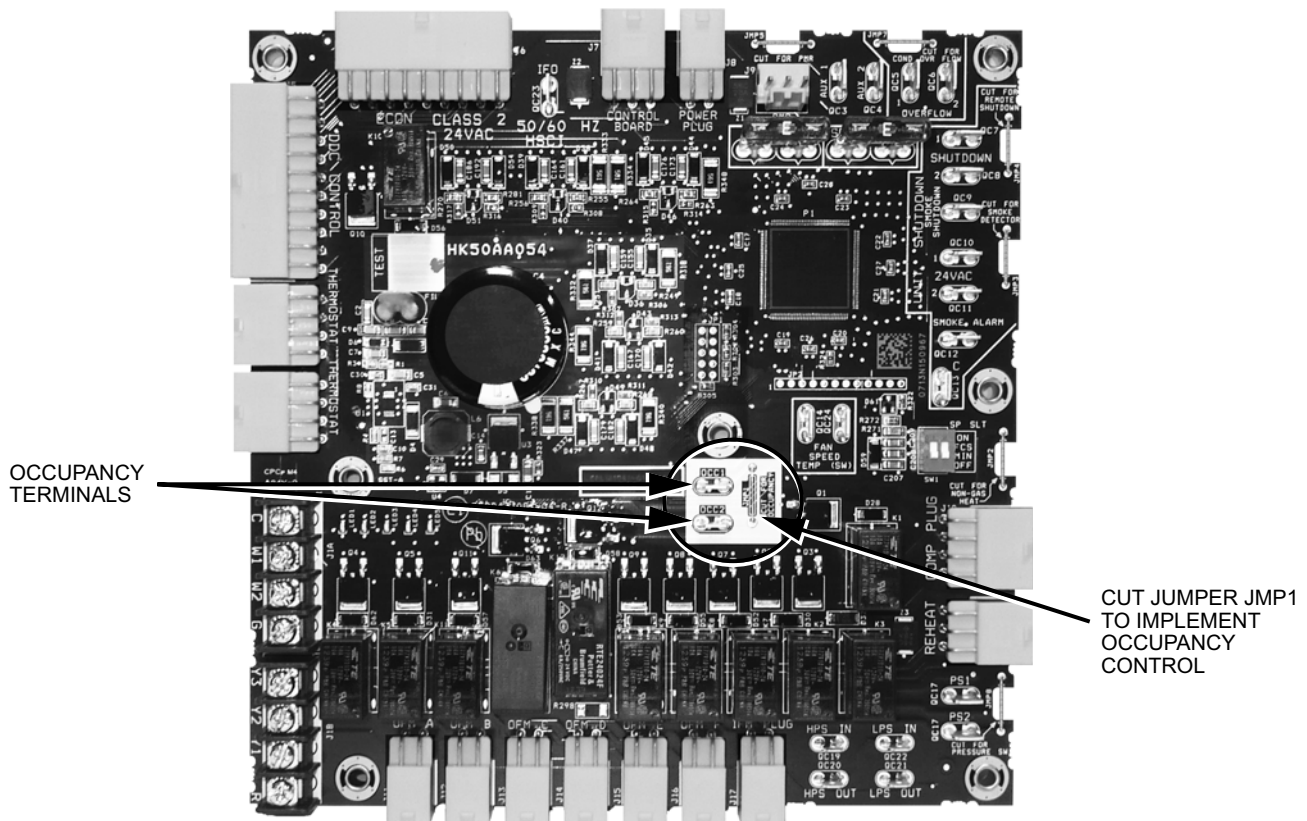

Fig. 54 - Integrated Staging Control (ISC) Board - Occupancy Terminals and Jumper

C13674



## Hardware

### Actuators —

The EconoMiSer® X damper actuators are direct-coupled types with spring-return. Power is 24-v from the W7220 outputs. Range of rotation is 95-degrees; timing for full-range movement is 90 seconds to drive open in normal operation, 30 seconds in Test Mode and 25 seconds for spring return.

These actuators are S-bus enabled. The S-bus is a proprietary local equipment network that connects the W7220 controller, one S-enabled actuator and up to three S-type enthalpy sensors on a two-wire communication network. The S-bus is polarity-insensitive. Devices attached to the S-bus are automatically recognized by the controller.

Actuator command position is defined in a 2-10 vdc value. 2.0-v is outside air damper position fully-closed (0% open); 10.0-v is damper position fully-open (100% open). See Table 8 to correlate control voltage values to outside air damper opening percentage.

**Table 8 – Actuator Voltage vs. Damper Position**

Vdc	% Open	Vdc	% Open	Vdc	% Open
2.0	0	4.8	35	7.6	70
2.4	5	5.2	40	8.0	75
2.8	10	5.6	45	8.4	80
3.2	15	6.0	50	8.8	85
3.6	20	6.4	55	9.2	90
4.0	25	6.8	60	9.6	95
4.4	30	7.2	65	10.0	100

These units use a 5-Nm (44 lb-in.) torque model, Honeywell Series MS3105K actuator.

### Supply Air Temperature Sensor —

The W7220 controller uses a 20-k ohm analog sensor for Supply Air Temperature (SAT). The thermistor is attached to a ring terminal. The ring terminal is attached to the unit's supply fan housing, downstream of the unit's indoor coil. The SAT sensor is connected to the W7220 input terminals marked MAT. See Table 9 for sensor resistance to temperature correlations.

The W7220 controller requires a valid signal from its SAT channel in order to function. If the SAT connection to the W7220 is lost, the W7220 will initiate an alarm condition immediately. No economizing operation will be permitted until this alarm is cleared.

**Table 9 – SAT/OAT Sensor Characteristics**

Deg C	Ohms	Deg F	Ohms
-30	415156	-20	386130
-25	301540	0	193070
-20	221210	20	101820
-15	163834	32	70200
-10	122453	40	55420
-5	92382	45	47771
0	70200	50	41258
5	53806	55	35725
10	41561	60	31035
15	32341	65	27069
20	25346	70	23719
25	20000	77	20000
30	15886	80	18473
35	12698	100	11544
40	10212	120	6768
45	8261		
50	6720		

### Outside Air Temperature Sensor —

EconoMiSer X systems equipped with outdoor dry bulb temperature changeover control include a 20-k ohm analog sensor to measure Outdoor Air Temperature (OAT). This is the same sensor used for the SAT function; see Table 9 for resistance vs temperature characteristics.

The OAT sensor is attached to the outside air damper frame. It is connected to the W7220's OAT input terminals.

If an accessory enthalpy sensor is added to an EconoMiSer X system with factory dry bulb changeover, disconnect this OAT sensor wiring at the W7220's OAT input terminals.

### Enthalpy Control Sensor Configuration—

The W7220 economizer control system can accommodate up to three S-bus enthalpy sensors. On EconoMiSer X models with factory-installed Enthalpy Changeover control, one S-bus sensor is provided in the economizer outdoor section. Additional sensors may be added to measure Return Air and Discharge Air conditions.

The Enthalpy Control sensor (Part Number: HH57AC081) communicates with the W7220 Economizer controller on the two-wire local equipment network bus (S-bus) and can either be wired using a two-pin header or using a side connector. This sensor is used for all OAT (Outdoor Air Temperature), RAT (Return Air Temperature) and DAT (Discharge Air Temperature), depending on how its three position DIP switch is set.

Use Fig. 55 and Table 10 to locate the wiring terminals for each Enthalpy Control sensor.

Use Fig. 55 and Table 11 to set the DIP switches for the desired use (location) of the sensor.

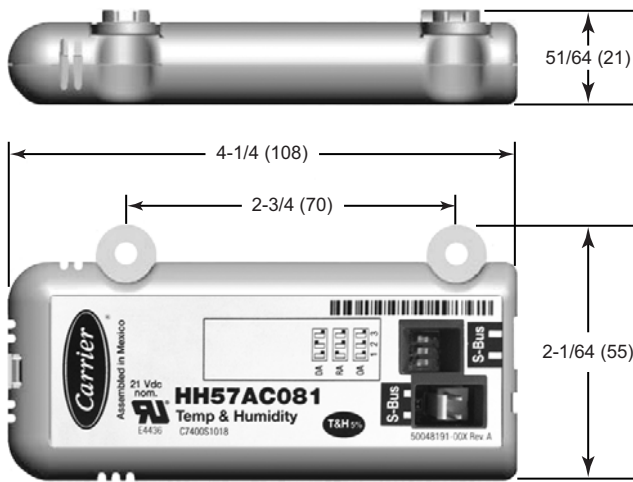

NOTE: Dimensions are in inches. Dimensions in ( ) are in mm.

a50-9614

**Fig. 55 - Enthalpy Control Sensor, Dimensions and DIP Switch Location**

**Table 10 – Enthalpy Control Sensor Wiring Terminations\***

Terminal		Type	Description
Nbr	Label		
1	S-BUS	S-BUS	S-Bus Communications (Enthalpy Control Sensor Bus)
2	S-BUS	S-BUS	S-Bus Communications (Enthalpy Control Sensor Bus)

\* Terminals are polarity insensitive.

**Table 11 – Enthalpy Control Sensor DIP Switch Settings**

Use	DIP Switch Positions for Switches 1, 2, and 3		
	1	2	3
DA	OFF	ON	OFF
RA	ON	OFF	OFF
OA	OFF	OFF	OFF

**Legend**

DA = Discharge Air  
 RA = Return Air  
 OA = Outside Air

When a S-bus sensor is connected to an existing network, it will take 60 minutes for the network to recognize and auto-configure itself to use the new sensor. During the 60 minute setup period, no alarms for sensor failures (except SAT) will be issued and no economizing function will be available.

**Operating Sequences**

**Staged Air Volume (3-Speed) Fan Motor —**

The Integrated Staging Control (ISC) Board in the main unit determines the operating speed (LOW/MED/HIGH) of the indoor fan based on space thermostat demand conditions. See Table 12 for this logic.

**Table 12 – Supply Fan Speed Logic without Economizer**

TSTAT OUTPUT				
G/OCC	0-V	<b>24-V</b>	0-V	0-V
Y1	0-V	<b>24-V</b>	0-V	0-V
Y2	0-V	0-V	<b>24-V</b>	0-V
Y3	0-V	0-V	0-V	<b>24-V</b>
W1	0-V	0-V	0-V	<b>24-V</b>
W2	0-V	0-V	0-V	<b>24-V</b>
SUPPLY FAN MOTOR SPEED	OFF	LOW	MED	HIGH

**W7220 Economizer Control —**

Tables 13 and 14 provide the W7220 Input/Output Logic. Table 13 describes economizer functions for a unit without a CO<sub>2</sub> sensor. Table 14 describes economizer functions for a unit with Demand Controlled Ventilation (CO<sub>2</sub> sensor connected). The supply fan speed is included in these tables for reference; this is neither an input or output of the W7220 controller.

**Base Unit Controls —**

Base unit includes standard electromechanical controls, Staged Air Volume (3-speed supply fan motor with VFD), EconoMi\$er® X (with W7220 controller) and thermostat or unitary controller that energizes the G terminal in cooling and heating to control the supply fan operation.

**Cooling, Unit with EconoMi\$er X without CO<sub>2</sub> Sensor —**

For Occupied mode operation of the EconoMi\$er X control, there must be a 24-v signal at terminal G at the unit's Integrated Staging Control Board from the thermostat; supply fan motor will start and run in Low Speed. The signal at G is connected to W7220 input OCC, placing the EconoMi\$er X control in Occupied mode; the economizer actuator is commanded open to the MIN POS L ventilation position. Removing the signal at OCC places the EconoMi\$er X control in Unoccupied mode; the economizer actuator is driven back to full-closed position.

When free cooling using outside air is not available, the unit cooling sequence will be controlled directly by the space thermostat. Thermostat call for Stage 1 Cooling energizes ISC terminals G and Y1; supply fan motor starts and runs in Low Speed. The Y1 demand is received at W7220 terminal Y1-I. Outside air damper position will be at MIN POS L. W7220 output Y1-O is energized; first stage mechanical cooling starts.

As space temperature falls and space cooling load is satisfied, the thermostat will remove its call for first stage cooling; ISC terminal Y1 call is removed. The W7220 input Y1-I is removed; output Y1-O is de-energized, stopping first stage cooling.

When ISC terminal Y1 is de-energized, terminal G may remain energized, indicating Continuous Fan operation.

The supply fan motor will continue to run in Low Speed. W7220 input OCC remains energized; the outside air damper remains in MIN POS L. If ISC terminal G is also de-energized with Y1, indicating AUTO Fan operation, then the supply fan motor will stop. The W7220 input at OCC is removed; the outside air damper closes.

If the space temperature continues to rise, the thermostat will call for second stage cooling; ISC terminal Y2 is also energized. The supply fan motor shifts to MED Speed. Outside air damper position will remain in MIN POS L, second stage cooling starts.

As space temperature falls, the thermostat will remove its call for second stage cooling; ISC terminal Y2 call is removed. The supply fan motor shifts back to Low Speed. The outside air damper remains at MIN POS L and the ISC board will stop second stage mechanical cooling.

If the space temperature continues to rise, the thermostat will call for third stage cooling; ISC terminal Y-3 is also energized. The supply fan motor shifts to High Speed. The outside air damper position will shift to MIN POS H, third stage cooling starts.

As space temperature falls, the thermostat will remove its call for third stage cooling; ISC terminal Y3 call is removed. The supply fan will shift to Medium Speed. The outside air damper position is repositioned to MIN POS L and stop third stage mechanical cooling.

When free cooling is available as determined by the appropriate changeover command (outdoor dry bulb,

outdoor enthalpy, differential dry bulb or differential enthalpy), a space thermostat call for Stage 1 Cooling energizes ISC terminals G and Y1; supply fan motor starts and runs in High Speed. The G demand is received at W7220 input OCC; outside air damper moves to MIN POS L. The Y1 demand is received at W7220 terminal Y1-I. The W7220 economizer control will modulate the outside air damper open and closed to maintain the unit cooling supply air temperature at setpoint MAT SET (default 53°F (12°C)). Compressor will not run.

During free cooling operation, a supply air temperature (SAT) above MAT SET will cause the outside air damper to modulate between MIN POS L setpoint and 100% open. As SAT decreases and approaches setpoint MA LO SET (default 45°F (7°C)), the outside air damper will maintain at the MIN POS L setting. With SAT below MA LO SET, the outside air damper will be closed or at minimum (see FREEZE POS). When SAT rises to MA LO SET plus 3°F, the outside air damper will re-open to MIN POS L setting.

Should 100% outside air not be capable of satisfying the space cooling load, space temperature will rise and the thermostat will call for second stage cooling; ISC terminal Y2 is also energized. The supply fan motor remains at High Speed. Outside air damper position will remain at MIN POS L, starting second stage cooling (Compressor 1 operation). Damper will modulate to maintain SAT at MAT SET concurrent with Compressor 1 operation.

**Table 13 – W7220 Input/Output without CO<sub>2</sub> Sensor**

INPUTS				Ref: FAN SPD*	OUTPUTS			
DEMAND CONTROLLED VENTILATION	OUTSIDE AIR Good to economize?	Y1-I	Y2-I		Mechanical Cooling Stage		Occupancy	
					Y1-O/1ST	Y2-O/2ND	OCC Yes	OCC No
NO CO <sub>2</sub> SENSOR	No	Off	Off	Low	0-v/Off	0-v/Off	MIN POS L	Closed
		On	Off	Low	24-v/On	0-v/Off	MIN POS L	Closed
		On	On	High	24-v/On	24-v/On	MIN POS H	Closed
	Yes	Off	Off	Low	0-v/Off	0-v/Off	MIN POS L	Closed
		On	Off	Low	0-v/Off	0-v/Off	Modulating: MIN POS L to Full-Open	Modulating: Closed to Full-Open
		On	On	High	2SP DELAY †; 24v/On	0-v/Off **	Modulating: MIN POS H to Full-Open	Modulating: Closed to Full-Open

\* Fan Speed for reference only; this is not an input or output function of the W7220.

† See Menu ADV SETUP -> 2SP FAN DELAY for details.

\*\* See Menu ADV SETUP -> STG# DLY. With Stage 3 delay enabled, control can turn on 2<sup>nd</sup> stage of cooling Y2-O after delay if the call for Y2-I has not been satisfied.

**Table 14 – W7220 Input/Output with Demand Controlled Ventilation (DCV)**

INPUTS				Ref: FAN SPD*	OUTPUTS			
DEMAND CONTROLLED VENTILATION	OUTSIDE AIR Good to economize?	Y1-I	Y2-I		Mechanical Cooling Stage		Occupancy	
					Y1-O/1ST	Y2-O/2ND	OCC Yes	OCC No
					Outside Air Damper Position			
Below set	No	Off	Off	Low	0-v/Off	0-v/Off	VENTMIN L	Closed
		On	Off	Low	24-v/On	0-v/Off	VENTMIN L	Closed
		On	On	High	24-v/On	24-v/On	VENTMIN H	Closed
	Yes	Off	Off	Low	0-v/Off	0-v/Off	VENTMIN L	Closed
		On	Off	Low	0-v/Off	0-v/Off	Modulating: VENTMIN L to Full-Open	Modulating: Closed to Full-Open
Above set	No	On	On	High	2SP DELAY †; 24v/On	0-v/Off **	Modulating: VENTMIN H to Full-Open	Modulating: Closed to Full-Open
		Off	Off	Low	0-v/Off	0-v/Off	Modulating: VENTMIN L to VENTMAX L	Closed
		On	Off	Low	24-v/On	0-v/Off	Modulating: VENTMIN L to VENTMAX L	Closed
	Yes	On	On	High	24-v/On	24-v/On	Modulating: VENTMIN H to VENTMAX H	Closed
		Off	Off	Low	0-v/Off	0-v/Off	Modulating: VENTMIN L to VENTMAX L	Closed
		On	Off	Low	0-v/Off	0-v/Off	Modulating: VENTMIN L to Full-Open	Modulating: Closed to Full-Open
On	On	High	2SP DELAY †; 24v/On	0-v/Off **	Modulating: VENTMIN H to Full-Open	Modulating: Closed to Full-Open		

\* Fan Speed for reference only; this is not an input or output function of the W7220.

† See Menu ADV SETUP -> 2SP FAN DELAY for details.

\*\* See Menu ADV SETUP -> STG# DLY. With Stage 3 delay enabled, control can turn on 2<sup>nd</sup> stage of cooling Y2-O after delay if the call for Y2-I has not been satisfied.

As space temperature falls, the thermostat will remove its call for second stage cooling; ISC terminal Y2 call is removed. The supply fan motor remains High Speed. The outside air damper limit is repositioned to between MIN POS L and 100% open. Second stage cooling (Compressor 1 operation) stops. As space temperature continues to fall and space cooling load is satisfied, the thermostat will remove its call for first stage cooling; ISC terminal Y1 call is removed. The W7220 input Y1-I is removed; free cooling mode ends. Outside air damper will remain at MIN POS L if supply fan remains in operation (CONT FAN) or to closed if supply fan stops (AUTO FAN).

Should 100% outside air and second stage cooling (Compressor 1 operation) not be capable of satisfying the space cooling load, space temperature will rise and the thermostat will call for third stage cooling: ISC terminal Y3 is also energized, starting third stage cooling (Compressor 2 operation). The supply fan motor will remain at High Speed. The Y3 demand is received at W7220 input Y2-I. The outdoor air damper position will modulate from MIN POS H to 100% Open to maintain SAT at MAT SET concurrent with Compressor 2 operation.

As space temperature falls, the thermostat will remove its call for third stage cooling; ISC terminal Y3 call is removed. The supply fan will remain at High Speed. The W7220 input Y2-I is also removed; the outside air damper is repositioned to modulate from MIN POS L to 100% Open, third stage cooling (Compressor 2 operation) stops.

**Power Exhaust:** If accessory power exhaust is installed, the power exhaust fan motors will be energized by the economizer control as the dampers open above the setpoint EXH1 SET L during Low Speed operation or EXH1 SET H during High Speed fan operation. The EXH1 output will be de-energized as the dampers close below the EXH1 setpoint value.

Damper movement from full closed to full open (or vice versa) will take approximately 1-1/2 minutes.

**Heating with EconoMiSer® X —**

When the space temperature calls for heat (W1 closes), ISC terminal W1 is energized. The supply fan will start and run in High Speed. The W1 signal will connect to W7220 input AUX2I; the outside air damper will move to MIN POS H. Unit heating sequence will follow base unit control sequences.

## **Demand Controlled Ventilation —**

If a space or return air CO<sub>2</sub> sensor is connected to the EconoMiSer<sup>®</sup> X control, a Demand Controlled Ventilation strategy will operate automatically.

When the space CO<sub>2</sub> level is below setpoint DCV SET (default 1100 ppm), the minimum ventilation position for the outside air damper will be reset to lower settings suited for offsetting CO<sub>2</sub> loads from space sources not including people. The settings will vary according to supply fan speed. When the supply fan speed is Low, the DCV minimum ventilation point is VENTMIN L. When the supply fan speed is High, the DCV minimum ventilation point is VENTMAX H.

As the CO<sub>2</sub> level in the space increases above the setpoint DCV SET (default 1100 ppm), the DCV ventilation position of the outside air damper will be increased proportionally, until the Maximum Ventilation setting is reached. The settings will vary according to supply fan speed. When the supply fan speed is Low, the DCV maximum ventilation point is VENTMAX L. When the supply fan speed is High, the DCV maximum ventilation point is VENTMAX H.

DCV operation will float between its VENTMIN and VENTMAX settings, never exceeding the VENTMAX limit as the space CO<sub>2</sub> level varies according to changes in people occupancy levels.

During concurrent demand for DCV and free cooling, the outdoor-damper will follow the higher demand condition from the DCV mode or from the free-cooling mode.

## **Setup and Configuration**

Before being placed into service, the W7220 Economizer module must be setup and configured for the installed system according to project control specifications.

Inspect all wiring connections at the Economizer module's terminals, and verify compliance with the installation wiring diagrams.

### **Initial Menu Display —**

On initial start up, Honeywell displays on the first line and Economizer W7220 on the second line. After a brief pause, the revision of the software appears on the first line and the second line will be blank.

### **Time-out and Screensaver —**

When no buttons have been pressed for 10 minutes, the LCD displays a screen saver, which cycles through the Status items. Each Status items displays in turn and cycles to the next item after 5 seconds.

<b>IMPORTANT:</b> During setup, the Economizer module is live at all times.
---

Setup and configuration involves stepping through three menus and enabling required functions and re-selecting setpoints to meet project requirements. The menus used are SYSTEM SETUP, ADV SETUP and SETPOINTS.

Obtain a copy of the project control specifications before starting setup and configuration process.

**NOTE:** W7220 will be in the “set up” mode for the first 60 minutes after powered. If a sensor for OA air or S-bus device (sensor, actuator) is disconnected during the set up mode, the W7220 will not alarm that failure. The SAT sensor is a system “critical” sensor, if the SAT sensor is removed during the set up mode, the W7220 will alarm. After 60 minutes the W7220 controller will change to operation mode and all components removed or failed will alarm in the operation mode.

For this application with the 2-speed supply fan option, note that parameters EQUIPMENT, AUX2I and FAN TYPE have required settings. Check that these parameters are set at these required settings:

EQUIPMENT must be CONV  
AUX2I must be W  
FAN SPEED must be 2SPEED

Press the ⏪ (EXIT) button to exit the SYSTEM SETUP menu and return to top level menu. Scroll down to ADV SETUP menu and press ⏩ (ENTER) button to enter this menu. Scroll down through the list of parameters and adjust settings as required. Be sure that the message CHANGE STORED appears with every change in parameter setting.

Press the ⏪ (EXIT) button to exit the ADV SETUP menu and return to top level menu. Scroll down to SETPOINTS menu and press ⏩ (ENTER) button to enter this menu. Scroll down through the list of parameters and adjust settings as required. Be sure that the message CHANGE STORED appears with every change in parameter setting.

**SETPOINT Defaults:** The default setpoint values represent many years of successful experience with economizing systems. Any changes that represent significant deviations from the default values should be well considered.

**DCV SETPOINT:** The default value for DCV SET is 1100 ppm. It is recommended that this setpoint be adjusted down to 500 ppm (or CO<sub>2</sub> level of outdoor air plus 100 ppm, whichever is higher) to permit an earlier initiation of the DCV mode as space occupancy increases.

## **Checkout**

For checkout, review the Status of each configured parameter by observing the scrolling display from the Screensaver mode or by entering the STATUS menu.

Use the Checkout menu (see Table 4 on page 43) to test the damper operation and any configured outputs. Only items that are configured are shown in the Checkout menu.

To perform a Checkout test:

1. Scroll to the desired test in the Checkout menu using the the ▲ and ▼ buttons.
2. Press the ← button to select the item.
3. RUN? appears.
4. Press the ← button to start the test.
5. The unit pauses and then displays IN PROGRESS.
6. When the test is complete, DONE appears.
7. When all desired parameters have been tested, press the ⬆ (Menu up) button to end the test.

The Checkout tests can all be performed at the time of installation or at any time during the operation of the system as a test that the system is operable.

**▲ CAUTION**

**EQUIPMENT DAMAGE HAZARD**

Failure to follow this caution may result in equipment damage.

Be sure to allow enough time for compressor startup and shutdown between checkout tests so that you do not short-cycle the compressors.

#### Status —

Use the STATUS menu (see pages 40 and 41) to check the parameter values for the various devices and sensors configured.

#### Calibration of Sensors —

There are up to six sensor calibration settings available in the ADV SETUP menu (depending on which sensors are connected to the W7220). See page 42 for this menu.

#### Resetting All Defaults —

Menu SYSTEM SETUP contains parameter FACTORY DEFAULT. This parameter will reset all setpoints back to factory default values.

To reset all values to defaults, scroll to the SYSTEM SETUP menu, enter the menu and scroll to parameter FACTORY DEFAULT. Enter this parameter and change the display value from NO to YES. Press ENTER ←.

After resetting all values, scroll up in SYSTEM SETUP to ensure the three parameters requiring special values for use with 2-speed fan system are correct.

## Troubleshooting

### Power Up Delay—

Upon power up (or after a power outage or brownout) the W7220 controller module begins a 5-minute power up delay before enabling mechanical cooling.

### Power Loss (Outage or Brownout) —

All setpoints and advanced settings are restored after any power loss or interruption.

**NOTE:** If the power goes below 18 Vac, the W7220 controller module assumes a power loss and the 5-minute power up delay will become functional when power returns above 18 Vac.

### Alarms —

The Economizer module provides alarm messages that display on the 2-line LCD.

**NOTE:** Upon power up, the module waits 60 minutes before checking for alarms. This allows time for all the configured devices (e.g. sensors, actuator) to become operational. The exception is the SAT sensor which will alarm immediately.

If one or more alarms are present and there has been no keypad activity for at least 5 minutes, the Alarms menu displays and cycles through the active alarms. You can also navigate to the Alarms menu at any time. The list of alarms included in Table 4 (see page 43) is not a complete list of available alarm messages. Each sensor has alarms for temperature, humidity and enthalpy. The list of possible alarms will vary from unit to unit as different sensors are connected.

### Clearing Alarms —

Once the alarm has been identified and the cause has been removed (e.g. replaced faulty sensor) the alarm can be cleared from the display.

To clear an alarm, perform the following:

1. Navigate to the desired alarm.
2. Press the ← button.
3. ERASE? displays.
4. Press the ← button.
5. ALARM ERASED displays.
6. Press the ⬆ (Menu up/Exit) button to complete the action and return to the previous menu.

**NOTE:** If the alarm still exists after you clear it, it is redisplayed within 5 seconds.

**Table 15 – Operating Issues and Concerns**

Issue or Concern	Possible Cause and Remedy
My outdoor temperature reading on the STATUS menu is not accurate.	Check the sensor wiring: <ul style="list-style-type: none"> <li>• Enthalpy sensors are to be wired to the S–Bus terminals.</li> <li>• Temperature sensors are to be wired to the OAT and MAT terminals.</li> </ul>
If my enthalpy sensor drifts in accuracy over time, can I re–calibrate it?	The sensor are not able to be re–calibrated in the field. However there is a menu item under the ADVANCED menu where you are able to input a limited offset in temperature and humidity for each sensor you have connected to the economizer.
Can I go back to factory defaults and start over?	Under the SYSTEM SETUP menu you can change the setpoints to the factory defaults.
Will I be able to see the LCD screen when it is in the unit?	The LCD screen has a backlight that is always illuminated.
What is a good setpoint for the Supply Air Temperature (SAT)?	The supply air temperature is the temperature of air that you want to supply to the space. In a commercial building, this is between 50 to 55°F (10 to 13°C). The supply air is the mixing of the return air and the outdoor air.
I am using enthalpy sensors. Why did the control ask me to input a dry bulb changeover temperature?	In the event the humidity sensor in the enthalpy sensors fails, the backup algorithm in the control is to default to the temperature sensor in the enthalpy sensor.
In checkout, the outdoor damper closes when I command it to open.	Check the actuator linkage or rotation. In the CHECKOUT mode, the outdoor damper should drive open or closed with the return air damper having the opposite effect.
How do I set my minimum position?	The minimum position is set using the VENTMIN and VENTMAX setup in the SETPOINTS menu. VENTMIN is the minimum ventilation required when using an occupancy sensor and VENTMAX is the minimum ventilation when not using an occupancy sensor for Demand Controlled Ventilation. The VENTMAX position is set the same as with the potentiometer on the analog economizers and is the output voltage to the damper actuator. The range is 2 Vdc closed OA damper and 10 Vdc open OA damper.
What if my damper does not go completely closed in the checkout operation?	Check the damper linkage or hub to make sure the damper is able to close completely.
How do I set the OCC?	There are two settings for the OCC setting, INPUT and ALWAYS. INPUT is from the space thermostat, if it has an occupancy output. ALWAYS is the unit in the occupied mode, if the economizer is powered (fan on).
Does the economizer save my program values if the unit loses power?	Yes, once the changes are stored in the controller they will be stored until they are changed by the operator.
If the unit is left in checkout, how long will the unit stay in checkout mode without input?	The unit will remain in checkout for 10 minutes, then return to normal operation.

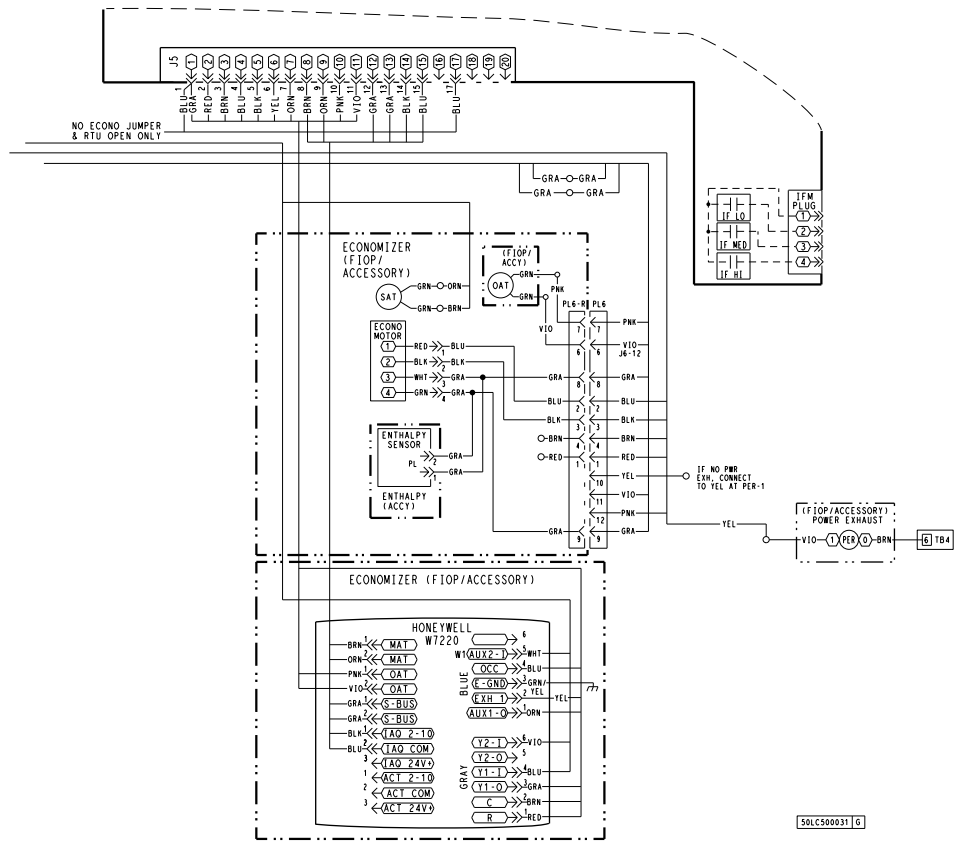

Fig. 56 - Typical EconMiSer® X Wiring Diagram

a48-9340



# CONTROL SET POINT AND CONFIGURATION LOG

Project Name/Location: \_\_\_\_\_

Model Number: \_\_\_\_\_

Serial Number: \_\_\_\_\_

Date: \_\_\_\_\_

Technician \_\_\_\_\_

Menu Tables:

1. SYSTEM SETUP
2. ADVANCED SETUP
3. SETPOINTS

**Menu 1: System Setup**

Parameter	Project Value	Parameter Default Value	Parameter Range and Increment	Notes
INSTALL		01/01/10		Display order = MM/DD/YY Setting order = DD, MM, then YY
UNITS DEG		_F	_F or _C	Sets economizer controller in degrees Fahrenheit or Celsius.
EQUIPMENT		CONV	CONV required for 2-speed mode	CONV = conventional; HP O/B = Enable Heat Pump mode; not available with 2-speed See Menu Note 4 (on page 43)
AUX2 I		W	W required for 2-speed mode	W = Informs controller that system is in heating mode. SD = Enables configuration of shutdown (not available on 2-speed) See Menu Note 4 (on page 43)
FAN TYPE		2speed	2speed required	Sets the economizer controller for operation of 1 speed or 2 speed indoor fan system. See Menu Note 4 (on page 43)
FAN CFM		5000cfm	100 to 15000 cfm;	UNIT DESIGN AIRFLOW (CFM) Enter ONLY if using DCVCAL ENA = AUTO The value is found in the Project Submittal documents for the specific RTU.
AUX OUT		NONE	NONE ERV EXH2 SYS	Select OUTPUT for AUX1 O relay NONE = not configured (output is not used) ERV = Energy Recovery Ventilator EXH2 = second damper position relay closure for second exhaust fan SYS = use output as an alarm signal
OCC		INPUT	INPUT or ALWAYS	OCCUPIED MODE BY EXTERNAL SIGNAL When using a setback thermostat with occupancy out (24 Vac), the 24-Vac is input to the OCC terminal. RTU control circuit provides 24-Vac to OCC through OCCUPIED terminals on Integrated Staging Control Board.
FACTORY DEFAULT		NO	NO or YES	Resets all set points to factory defaults when set to YES. LCD will briefly flash YES and change to NO but all parameters will change to the factory default values. <b>RECHECK AUX2 I and FANTYPE for required 2-speed values.</b>

## Menu 2: Advanced Setup

Parameter	Project Value	Parameter Default Value	Parameter Range and Increment	Notes
MA LO SET		45°F (7°C)	35 to 55°F; (2 to 13°C) incremented by 1°	SUPPLY AIR TEMPERATURE LOW LIMIT Temperature to achieve Freeze Protection (close damper and alarm if temperature at SAT location falls below setup value)
FREEZE POS		CLO	CLO or MIN	FREEZE PROTECTION DAMPER POSITION Damper position when freeze protection is active CLO = closed MIN = MIN POS or VENTMAX
CO2 ZERO		0ppm	0 to 500 ppm; Increment by 10	CO <sub>2</sub> ppm level to match CO <sub>2</sub> Sensor start level.
CO2 SPAN		2000ppm	1000 to 3000 ppm; Increment by 50	CO <sub>2</sub> ppm span to match CO <sub>2</sub> sensor.
STG3 DLY		2.0h	0 min, 5 min, 15 min, then 15 min intervals. Up to 4 h or OFF	COOLING STAGE 3 DELAY Delay after stage 2 for cool has been active. Turns on 2nd stage of cooling when economizer is 1st stage and mechanical cooling is 2nd
SD DMPR POS		CLO	CLO or OPN	Function NOT AVAILABLE with 2--speed mode
DCVCAL ENA		MAN	MAN (manual)	Turns on the DCV automatic control of the dampers. Resets ventilation
MAT T CAL	0.0	1.0°F (or °C)	+/- 2.5°F (+/-1.4°C)	SUPPLY AIR TEMPERATURE CALIBRATION Allows for the operator to adjust for an out of calibration supply air temperature (SAT) sensor
OA T CAL	2.0	3.0°F (or °C)	+/- 2.5°F (+/-1.4°C)	OUTSIDE AIR TEMPERATURE CALIBRATION Allows for the operator to adjust for an out of calibration outside air temperature (OAT) sensor
OA H CAL		0% RH	+/- 10% RH	OUTSIDE AIR HUMIDITY CALIBRATION Allows for the operator to adjust for an out of calibration of outside air enthalpy sensor
RA T CAL	4.0	5.0°F (or °C)	+/- 2.5°F (+/-1.4°C)	RETURN AIR TEMPERATURE CALIBRATION Allows for the operator to adjust for an out of calibration return air temperature (RA) sensor
RA H CAL		0% RH	+/- 10% RH	RETURN AIR HUMIDITY CALIBRATION Allows for the operator to adjust for an out of calibration return air enthalpy sensor
DA T CAL	0.0	1.0°F (or °C)	+/- 2.5°F (+/-1.4°C)	DISCHARGE AIR TEMPERATURE CALIBRATION Allows for the operator to adjust for an out of calibration discharge air temperature (DAT) sensor
2SP FAN DELAY		5 Minutes	0 to 20 minutes in 1 minute increments	TIME DELAY ON 2ND STAGE ECONOMIZING While in the Economizing mode, this is the delay between thermostat Y2 call and Y1-O output to mechanical cooling stage, to allow high speed fan operation to attempt to cool space first.

### Menu 3: Setpoints

Parameter	Project Value	Parameter Default Value	Parameter Range and Increment	Notes
MAT SET		53°F (12°C)	38 to 65°F; (3 to 18°C) increment by 1°	SUPPLY AIR SETPOINT Setpoint determines where the economizer will modulate the OA damper to maintain the supply air temperature. See Menu Note 2 (on page 43).
LOW T LOCK		32°F (0°C)	-45 to 80°F (-43 to 27°C) increment by 1°	COMPRESSOR LOW TEMPERATURE LOCKOUT Setpoint determines outdoor temperature when the mechanical cooling cannot be turned on.
DRYBLB SET		63°F (17°C)	48 to 80°F; (9 to 27°C) increment by 1°	OA DRY BULB TEMPERATURE CHANGEOVER SETPOINT Setpoint determines where the economizer will assume outdoor air temperature is good for free cooling; e.g.: at 63°F (17°C), unit will economize at 62°F (16.7°C) and below and not economize at 64°F (17.8°C) and above. There is a 2°F (1.1°C) deadband. See Menu Note 3 (on page 43).
ENTH CURVE		ES3	ES1, ES2, ES3, ES4, or ES5	ENTHALPY CHANGEOVER CURVE (Requires enthalpy sensor option) Enthalpy boundary "curves" for economizing using single enthalpy.
DCV SET		1100ppm	500 to 2000 ppm; increment by 100	DEMAND CONTROLLED VENTILATION SETPOINT Displays only if CO <sub>2</sub> sensor is connected. Setpoint for Demand Controlled Ventilation of space. Above the setpoint, the OA dampers will modulate open to bring in additional OA to maintain a space ppm level below the setpoint.
MIN POS L		6.0 V	2 to 10Vdc	VENTILATION MINIMUM POSITION AT LOW SPEED Displays ONLY if a CO <sub>2</sub> sensor is NOT connected.
MIN POS H		4.4 V	2 to 10Vdc	VENTILATION MINIMUM POSITION AT HIGH SPEED Displays ONLY if a CO <sub>2</sub> sensor is NOT connected.
VENTMAX L		6.0 V	2 to 10Vdc	DCV MAXIMUM DAMPER POSITION AT LOW SPEED (Requires CO <sub>2</sub> sensor connected)
VENTMAX H		4.4 V	2 to 10Vdc	DCV MAXIMUM DAMPER POSITION AT HIGH SPEED (Requires CO <sub>2</sub> sensor connected)
VENTMIN L		3.7 V	2 to 10Vdc	DCV MINIMUM DAMPER POSITION AT LOW SPEED (Requires CO <sub>2</sub> sensor connected)
VENTMIN H		2.8 V	2 to 10Vdc	DCV MINIMUM DAMPER POSITION AT HIGH SPEED (Requires CO <sub>2</sub> sensor connected)
ERV OAT SP		32°F (0°C)	0 to 50°F; (-18 to 10°C) increment by 1°	ENERGY RECOVERY VENTILATION UNIT OUTDOOR AIR TEMPERATURE SETPOINT Only when AUX1 O = ERV
EXH1 L SET		65%	0 to 100%; increment by 1	EXHAUST FAN STAGE 1 SETPOINT AT LOW SPEED Setpoint for OA damper position when exhaust fan1 is powered by the economizer.
EXH1 H SET		50%	0 to 100%; increment by 1	EXHAUST FAN STAGE 1 SETPOINT AT HIGH SPEED Setpoint for OA damper position when exhaust fan1 is powered by the economizer.
EXH2 L SET		80%	0 to 100%; increment by 1	EXHAUST FAN STAGE 2 SETPOINT AT LOW SPEED Setpoint for OA damper position when exhaust fan 2 is powered by the economizer. Only used when AUX1 -O is set to EHX2.
EXH2 H SET		75%	0 to 100%; increment by 1	EXHAUST FAN STAGE 2 SETPOINT AT HIGH SPEED Setpoint for OA damper position when exhaust fan 2 is powered by the economizer. Only used when AUX1 -O is set to EHX2.

## Staged Air Volume (SAV™) with Variable Frequency Drive

The Staged Air Volume (SAV) system utilizes a Variable Frequency Drive (VFD) to automatically adjust the indoor fan motor speed in sequence with the unit's ventilation, cooling and heating operation. Per ASHRAE 90.1-2016 standard during the first stage of cooling operation the SAV system will adjust the fan motor to provide 66% of the design airflow rate for the unit. When the call for the second stage of cooling is required, the SAV system will allow the design airflow rate for the unit established (100%). During the heating mode, the SAV system will allow total design airflow rate (100%) operation. During ventilation mode, the SAV system will operate the fan motor at 66% speed.

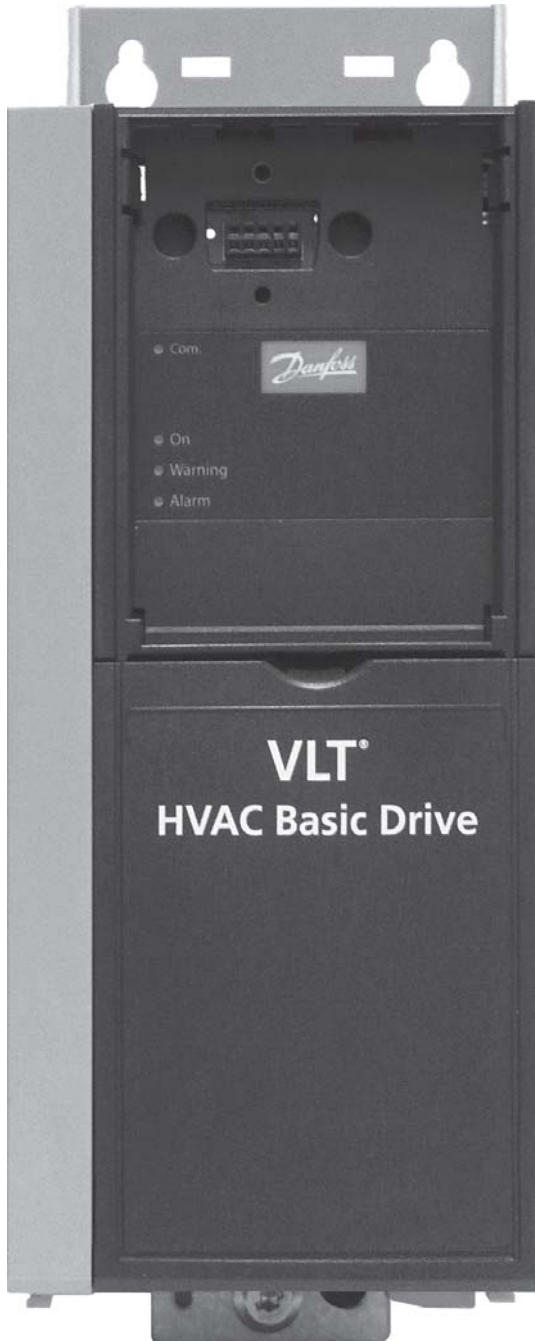

C13110

**Fig. 57 - Variable Frequency Drive (VFD)**

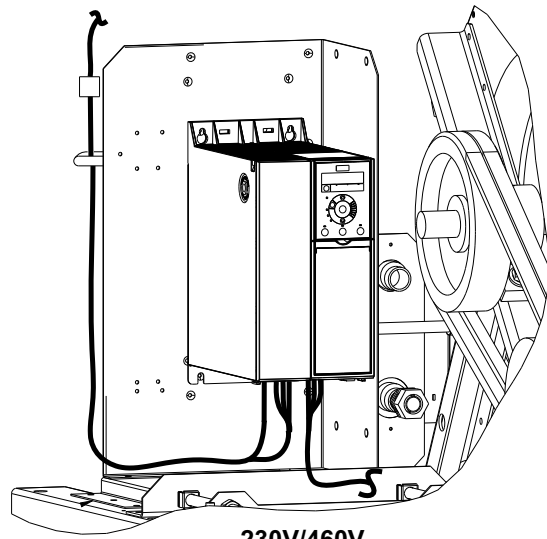

230V/460V

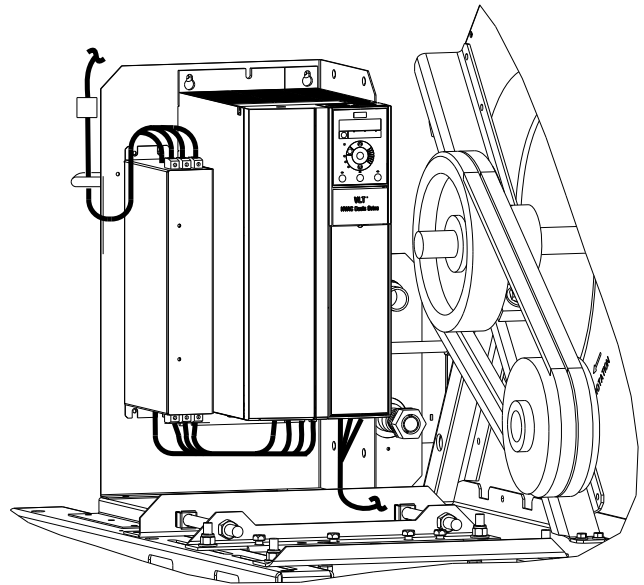

575V ONLY

**Fig. 58 - VFD Location**

C13209

## Multi-Speed VFD Display Kit (Field-Installed Accessory)

**NOTE:** The Remote VFD Keypad is part of the Multi-Speed VFD display kit (PN: CRDISKIT002A00) which is a field-installed accessory. It is not included with the 50LC size 14-26 base units.

The VFD keypad as shown in Fig. 59 consists of the following sections:

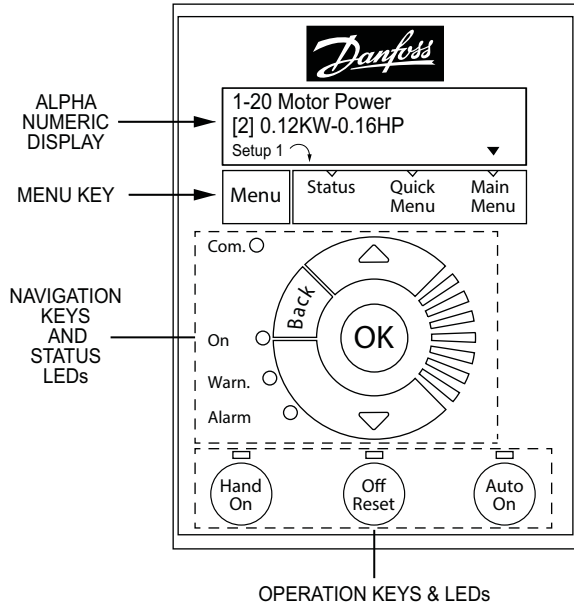

C13112

**Fig. 59 - VFD Keypad**

**Alpha Numeric Display:** The LCD display is back lit with 2 alpha-numeric lines. All data is displayed on the LCD.

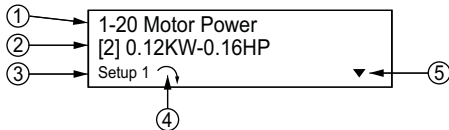

C13113

1	Parameter number and name.
2	Parameter value.
3	Setup number shows the active setup and the edit setup. If the same set-up acts as both the active and edit set-up, only that setup number is shown (factory setting). When the active and edit setup differ, both numbers are shown in the display (SETUP 12). The flashing number indicates the edit setup.
4	The symbol in the number 4 position in the figure above indicates motor direction. The arrow point either clockwise or counter-clockwise to show the motor's current direction.
5	The position of the triangle indicates the currently selected menu: Status, Quick Menu or Main Menu.

**Menu Key:** Use the Menu key to select between Status, Quick Menu or Main Menu. The triangle icon at the bottom of the LCD display indicates the currently selected mode. (See number 5 in the table above.)

**Navigation Keys and Status LEDs:** The Navigation keys and Status LEDs are detailed in the following table.

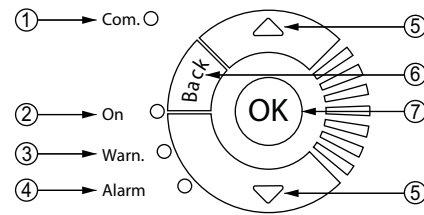

C13114

1	<b>Com. LED:</b> Flashes when bus communications is communicating.
2	<b>Green LED/On:</b> Control selection is working.
3	<b>Yellow LED/Warn.:</b> Indicates a warning.
4	<b>Flashing Red LED/Alarm:</b> Indicates an alarm.
5	<b>Arrows ▲▼:</b> Use the Up and Down arrow keys to navigate between parameter groups, parameters and within parameters. Also used for setting local reference.
6	<b>Back key:</b> Press to move to the previous step or layer in the navigation structure.
7	<b>OK key:</b> Press to select the currently displayed parameter and for accepting changes to parameter settings.

**Operation Keys and LEDs:** The following table details the functions of the Operating keys. An illuminated yellow LED above the key indicates the active key.

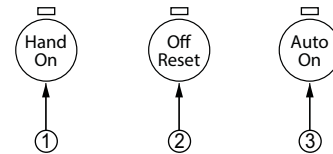

C13115

1	<b>Hand On key:</b> Starts the motor and enables control of the variable frequency drive (VFD) via the VFD Keypad option. <b>NOTE:</b> Please note that terminal 27 Digital Input (5-12 Terminal 27 Digital Input) has coast inverse as default setting. This means that the Hand On key will not start the motor if there is no 24V to terminal 27, so be sure to connect terminal 12 to terminal 27.
2	<b>Off/Reset key:</b> Stops the motor (off). If in alarm mode the alarm will be reset.
3	<b>Auto On key:</b> The variable frequency drive is controlled either via control terminals or serial communication.

### Connecting the Keypad to the VFD

The VFD keypad can be mounted directly to the variable frequency drive, provided you can easily access the front panel of the VFD. If you do not have easy access to the VFD front panel, use the cable included with the kit to connect the keypad to the VFD.

### Connecting the Keypad Directly to the VFD —

1. Place the bottom of the VFD keypad into the variable frequency drive as shown in Fig. 60.

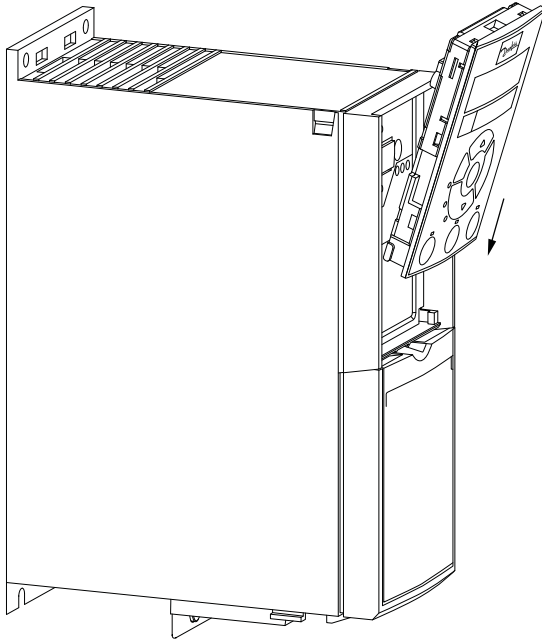

C13116

**Fig. 60 - Align Bottom of VFD Keypad with Opening in VFD Front Panel**

2. Push the top of the VFD keypad into the variable frequency drive as shown in Fig. 61.

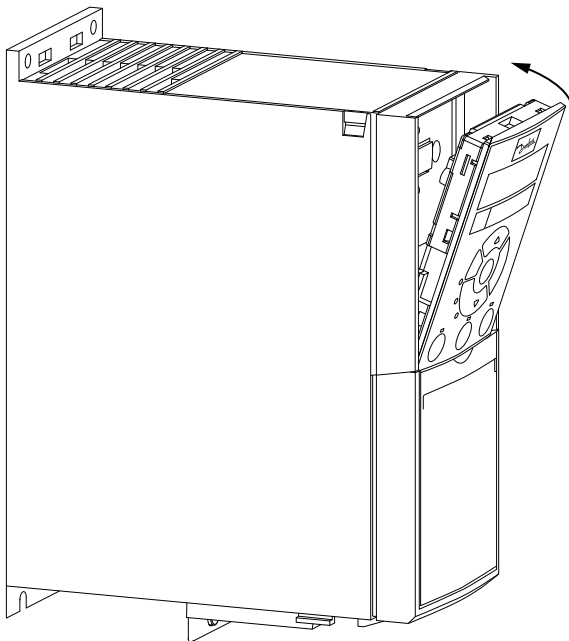

C13117

**Fig. 61 - Secure Keypad in Place**

### Using the Cable to Connect the Keypad to the VFD —

The VFD keypad can be connected to the variable frequency drive via the cable included with the Multi-Speed VFD display kit (PN: CRDISKIT002A00).

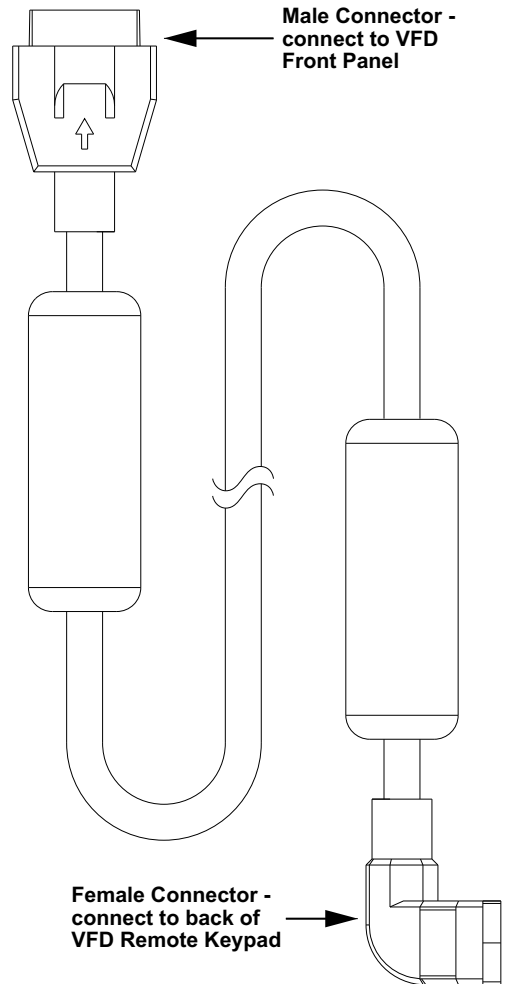

C13118

**Fig. 62 - VFD Remote Keypad Cable**

1. Connect the male end of the cable to the front panel of the variable frequency drive. Use 2 of the screws included with the kit to secure the cable to the VFD.
2. Connect the female end of the cable to the back panel of the VFD Remote keypad. Secure the cable to the remote keypad using the 2 remaining screws from the kit.

### **Program the VFD for 3 Discrete Indoor Fan Speeds**

**IMPORTANT:** 50LC 14-26 units are programmed at the factory for 3 discrete indoor fan speeds. The following procedure is only to be used to recover this function after an event such as a system crash.

**NOTE:** This procedure requires use of the VFD Keypad which is included as part of the field-installed Multi-Speed VFD display kit (PN: CRDISKIT002A00). If the VFD keypad is not already installed, install it. See “Connecting the Keypad to the VFD” for details.

### **To program the VFD for 3 discrete indoor fan motor speeds:**

1. At Power-Up:  
At the first power up the LCD displays the Select Language screen. The default setting is English. To

change the language, press the **OK** key and use the **▲** and **▼** keys to scroll to the desired language and then press **OK**.

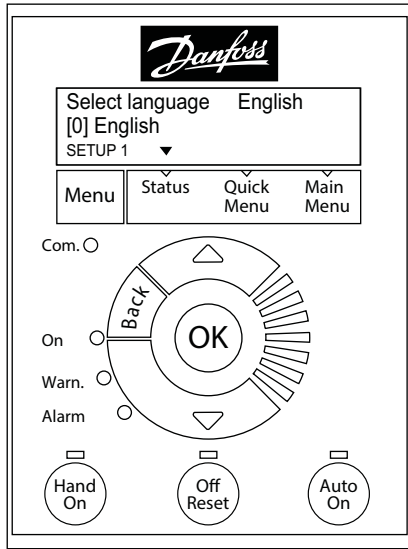

C13119

**Fig. 63 - Keypad with Power Up Screen Displayed**

## 2. Selecting Regional Settings:

- Press the **Off Reset** key.
- Press the **Menu** key to move the **▼**(triangle icon) so it is positioned over **Main Menu**. The display show the following -

0 - ** Operation / Display
1 - ** Load and Motor

- Press the **OK** key, the display changes to -

0-0* Basic Settings
0-1* Set-up Operations

- With the top row highlighted, press **OK**. The display changes to -

0-01 Language
[0] English

**NOTE:** If English is not the desired language press **OK**, select the desired language and press **OK** again.

- Press **▼(Down Arrow)** key) once; the display changes to -

0-03 Regional Settings
[0] International

- Press **OK**; the [0] is now highlighted.

- Press **▼(Down Arrow)** key once; the display changes to -

0-03 Regional Settings
[1] North America

- Press **OK**

**NOTE:** If the Alarm 060 appears, follow Step 3 to clear the alarm. Make sure to press **Off Reset** when done. If there is no alarm, continue at Step 4.

## 3. Clearing Alarm 060: External Interlock:

- Press the **Menu** key twice to position the **▼**(triangle icon) over **Main Menu**; the display changes to -

0 - ** Operation / Display
1 - ** Load and Motor

- Press the **▼(Down Arrow)** key until the following display appears -

4 - ** Limits / Warnings
5 - ** Digital In/Out

- Press **OK**. The display changes to -

5-0* Digital I/O mode
5-1* Digital Inputs

- Press **▼(Down Arrow)** once to highlight the bottom row and press **OK**. The display changes to -

5-10 Terminal 18 Digital In...
[8] Start

- Press **▼(Down Arrow)** twice; the following display appears-

5-12 Terminal 27 Digital In...
[7] External Interlock

- Press **OK** to highlight the number in the bracket.

- Press **▼(Down Arrow)** until the following display appears -

5-12 Terminal 27 Digital In...
[0] No operation

- Press **OK**.

- Press **Off Reset**. The Alarm indicator disappears.

## 4. Entering Grid Type:

- Press the **Menu** key to move the **▼**(triangle icon) so it is positioned over **Main Menu**. The display show the following -

0-0* Basic Settings
0-1* Set-up Operations

- Press **OK** twice: the display changes to -

0-01 Language
[0] English

- Press **▼(Down Arrow)** three times, to reach the following display -

0-06 Grid Type
[102] 200-240V/60Hz

- Press **OK** to highlight the number in the bracket and then use the **▲** and **▼ (Up and Down Arrow)** keys to select the desired voltage and Hertz for the unit.

- Press **OK** to accept the selection and continue.

5. Entering Motor Data:

- a. Press the **Menu** key to move the ▼(triangle icon) so it is positioned over Main Menu. The display show the following -

0 - ** Operation / Display
1 - ** Load and Motor

- b. Press ▼(Down Arrow) once to highlight the bottom row.  
 c. Press **OK**, the display changes to -

1 - 0* General Settings
1 - 1* Motor Selection

- d. Press ▼(Down Arrow) twice to reach the following display -

1 - 1* Motor Selection
1 - 2* Motor Data

- e. Press **OK**, the following display appears -

1-20 Motor Power
[9] 1.5kW - 2 hp

**NOTE:** The number in the bracket may be different from what is shown above.

- f. Press **OK** and then use the ▲ and ▼ (Up and Down Arrow) keys to scroll to the proper motor horsepower. Press **OK** again to set the selected hp.  
 g. Press ▼(Down Arrow) once, the following display appears -

1-22 Motor Voltage
230V

- h. Press **OK** to highlight the voltage value. Use the ▲ and ▼ (Up and Down Arrow) keys to select the nameplate voltage. Press **OK** again to set the selected voltage.  
 i. Press ▼(Down Arrow) once to display the following -

1-23 Motor Frequency
60Hz

- j. Press **OK** to highlight the Frequency value and then use the ▲ and ▼ (Up and Down Arrow) keys to select the nameplate Hz. Press **OK** again to set the selected Hz.  
 k. Press ▼(Down Arrow) once to display the following -

1-24 Motor Current
6.61A

- l. Press **OK** to highlight the Current value and then use the ▲ and ▼ (Up and Down Arrow) keys to select the Max Amps value provided. Press **OK** again to set the selected Max Amps.

**NOTE:** The Max Amps is greater than the nameplate value. Check the VFD Unit Parameters (see Tables 16 - 20 on pages 68 - 72) and use the value listed for the given unit in the column labeled “Motor Current Must-Hold Amps”.

- m. Press ▼(Down Arrow) once to display the following -

1-25 Motor Nominal Speed
1740rpm

- n. Press **OK** to highlight the rpm value and then use the ▲ and ▼ (Up and Down Arrow) keys to select the nameplate rpm. Press **OK** again to set the selected rpm.

6. Entering Parameters for 1-71, 1-73, 1-82, and 1-90:

- a. Press the **Menu** key to move the ▼(triangle icon) so it is positioned over Main Menu. The display show the following -

0 - ** Operation / Display
1 - ** Load and Motor

- b. Press ▼(Down Arrow) once to highlight the bottom row.  
 c. Press **OK**, the display changes to -

1 - 0* General Settings
1 - 1* Motor Selection

- d. Press ▼(Down Arrow) until the following display appears -

1 - 6* Load Depen. Setting
1 - 7* Start Adjustments

- e. Press **OK**, the following display appears -

1-71 Start Delay
2.0s

- f. Press **OK** to highlight the number and then use the ▲ and ▼ (Up and Down Arrow) keys to select the number provided in Tables 16 - 20. Press **OK** again to set the selected value.  
 g. Press ▼(Down Arrow) twice, the following display appears -

1-73 Flying Start
[1] Enabled

- h. Press **OK** to highlight the number in the bracket and then use the ▲ and ▼ (Up and Down Arrow) keys to select the number provided in Tables 16 - 20. Press **OK** again to set the selected value.  
 i. Press the **Back** key once, the following display appears -

1 - 6* Load Depen. Setting
1 - 7* Start Adjustments

- j. Press ▼(Down Arrow) once, the following display appears -

1 - 7* Start Adjustments
1 - 8* Stop Adjustments

- k. Press **OK**, the following display appears -

1-80 Function at Stop
[0] Coast



- l. Press **▼(Down Arrow)** once, the following display appears -

1-82 Min Speed for Functio...
1.0 Hz

- m. Press **OK** to highlight the number and then use the **▲** and **▼ (Up and Down Arrow)** keys to select the number provided in Tables 16 - 20. Press **OK** again to set the selected value.

- n. Press the **Back** key once, the following display appears -

1-7* Start Adjustments
1-8* Stop Adjustments

- o. Press **▼(Down Arrow)** once, the following display appears -

1-8* Stop Adjustments
1-9* Motor Temperature

- p. Press **OK**, the following display appears -

1-90 Motor Thermal Prote...
[4] ETR trip 1

- q. Press **OK** to highlight the number in the bracket then use the **▲** and **▼ (Up and Down Arrow)** keys to select the number provided in Tables 16 - 20. Press **OK** again to set the selected value.

#### 7. Setting References:

- a. Press the **Menu** key to move the **▼(triangle icon)** so it is positioned over Main Menu. The display show the following -

0- ** Operation / Display
1- ** Load and Motor

- b. Press **▼(Down Arrow)** three times, the following display appears -

2- ** Brakes
3- ** Reference / Ramps

- c. Press **OK**, the following display appears -

3-0* Reference Limits
3-1* References

- d. Press **OK** again, the following display appears -

3-02 Minimum Reference
0.000

**NOTE:** If the bottom row displays a number other than 0.000, press **OK** and use the **▲** and **▼ (Up and Down Arrow)** key to select 0.000.

- e. Press **▼(Down Arrow)** once, the following display appears -

3-03 Maximum Reference
60.000

**NOTE:** If the bottom row displays a number other than 60.000, press **OK** and use the **▲** and **▼ (Up and Down Arrow)** keys to select 60.000.

- f. Press the **Back** key until the following display appears -

3-0* Reference Limits
3-1* References

- g. Press **▼(Down Arrow)** once to move the highlight to the bottom row and then press **OK**. The following display appears -

3-10 Preset Reference
[0]0.00%

- h. Press **OK** once to highlight the number in the bracket. Press **OK** again; the highlight moves to the current percent value.

Use the **▲** and **▼ (Up and Down Arrow)** keys and the following table to enter the required Preset Reference values.

[0]0.00%	Stop
[1]LL.LL%	Low Speed (see Tables 16 - 20, column labeled "Preset References 3-10[1]" for the proper % for each unit)
[2]MM.MM%	Medium Speed (see Tables 16 - 20, column labeled "Preset References 3-10[2]" for the proper % for each unit)
[3]100%	Override (High Speed)
[4]100%	High Speed (100% or close to 100% to achieve the required CFM at high speed)
[5]0.00%	Stop
[6]0.00%	Stop
[7]0.00%	Stop

#### 8. Setting the Ramp Time:

- a. Press the **Back** key until the following display appears -

3-0* Reference Limits
3-1* References

- b. Press **▼(Down Arrow)** twice, the following display appears -

3-1* References
3-4* Ramp 1

- c. Press **OK**, the following display appears -

3-41 Ramp 1 Ramp up Time
3.00s

- d. Press **OK** again to highlight the bottom row and use the **▲** and **▼ (Up and Down Arrow)** keys to select 10.00s. Press **OK** again to set the selected Ramp up Time.

- e. Press **▼(Down Arrow)** once, the following display appears -

3-42 Ramp 1 Ramp Down Time
3.00s

- f. Press **OK** again to highlight the bottom row and use the **▲** and **▼** (**Up** and **Down Arrow**) keys to select 10.00s. Press **OK** again to set the selected Ramp Down Time.

#### 9. Setting Limits:

- a. Press the **Back** key until the following display appears -

2- ** Brakes
3- ** Reference / Ramps

- b. Press **▼**(**Down Arrow**) once, the following display appears -

3- ** Reference / Ramps
4- ** Limits / Warnings

- c. Press **OK**, the following display appears -

4- 1* Motor Limits
4- 4* Adj. Warning 2

- d. Press **OK** again, the following display appears -

4-10 Motor Speed Direction
[2] Both Directions

- e. Press **▼**(**Down Arrow**) once, the following display appears -

4-12 Motor Speed Low Limi...
0.0Hz

- f. Press **▼**(**Down Arrow**) again, the following display appears -

4-14 Motor Speed High Limi...
65.0Hz

**NOTE:** Press **OK** to highlight the Hz value and then use the **▲** and **▼** (**Up** and **Down Arrow**) keys to enter the required values.

- g. Press **▼**(**Down Arrow**) once, the following display appears -

4-18 Current Limit
110%

**NOTE:** Press **OK** to highlight the % value and then use the **▲** and **▼** (**Up** and **Down Arrow**) keys to enter the required value. See Tables 16 - 20 for proper selection of the value for this parameter then press **OK** to set the selected value.

- h. Press **▼**(**Down Arrow**) once, the following display appears -

4-19 Max Output Frequency
65.0Hz

**NOTE:** Press **OK** to highlight the Hz value and then use the **▲** and **▼** (**Up** and **Down Arrow**) keys to enter the required values.

#### 10. Setting Digital Inputs:

- a. Press the **Back** key until the following display appears -

3- ** Reference / Ramps
4- ** Limits / Warnings

- b. Press **▼**(**Down Arrow**) once, the following display appears -

4- ** Limits / Warnings
5- ** Digital In/Out

- c. Press **OK**, the following display appears -

5- 0* Digital I/O mode
5- 1* Digital Inputs

- d. Press **▼**(**Down Arrow**) once to move the highlight to the bottom row and then press **OK**. The following display appears -

5-10 Terminal 18 Digital In...
[8] Start

- e. Press **▼**(**Down Arrow**) again. The following display appears -

5-11 Terminal 19 Digital In...
[16] Preset ref bit 0

- f. Press **▼**(**Down Arrow**) again. The following display appears -

5-12 Terminal 27 Digital In...
[17] Preset ref bit 1

- g. Press **▼**(**Down Arrow**) again. The following display appears -

5-13 Terminal 29 Digital In...
[18] Preset ref bit 2

**NOTE:** By pressing **OK** the number in the bracket can be changed until the desired number appears. Press **OK** again to set the selected value.

#### 11. Setting Analog Inputs:

- a. Press the **Back** key until the following display appears -

4- ** Limits / Warnings
5- ** Digital In/Out

- b. Press **▼**(**Down Arrow**) until the following display appears -

5- ** Digital In/Out
6- ** Analog In/Out

- c. Press **OK**, the following display appears -

6- ** Analog In/Out
6- 1* Analog Input 53

- d. Press ▼(Down Arrow) once to move the highlight to the bottom row and then press **OK**. The following display appears -

6-10 Terminal 53 Low Voltage 2V
------------------------------------

- e. Press ▼(Down Arrow) once to move the highlight to the bottom row and then press **OK**. The following display appears -

6-11 Terminal 53 High Voltage [10V]
--

- f. Press ▼(Down Arrow) once to move the highlight to the bottom row and then press **OK**. The following display appears -

6-14 Set Min Reference [0 Hz]
----------------------------------

- g. Press ▼(Down Arrow) once to move the highlight to the bottom row and then press **OK**. The following display appears -

6-15 Set Max Reference [60 Hz]
-----------------------------------

## 12. Setting Reset Mode and RFI Filter:

- a. Press the **Back** key until the following display appears -

0 – ** Operation / Display
1 – ** Load and Motor

- b. Press ▼(Down Arrow) until the following display appears -

13 – ** Smart Logic
14 – ** Special Functions

- c. Press **OK**, the following display appears -

14 – 0* Inverter Switching
14 – 1* Mains On/Off

- d. Press ▼(Down Arrow) twice. The following display appears -

14 – 1* Mains On/Off
14 – 2* Reset Functions

- e. Press **OK**, the following display appears -

14-20 Reset Mode [0] Manual reset
--------------------------------------

- f. Press **OK** to highlight the number in the bracket.

- g. Use the ▲ and ▼ (Up and Down Arrow) keys to change the number to 3 for 3 automatic resets and then press **OK**. The display changes to -

14-20 Reset Mode [3] Automatic reset x 3
---

- h. Press ▼(Down Arrow) once, the following display appears -

14-21 Automatic Restart T... 10s
-------------------------------------

- i. Press **OK** to highlight the number of seconds and use the ▲ and ▼ (Up and Down Arrow) keys to select 600 seconds. Press **OK** again to set the selected value.

- j. Press the **Back** key once, the following display appears -

14 – 1* Mains On/Off
14 – 2* Reset Functions

- k. Press ▼(Down Arrow) twice, the following display appears -

14 – 4* Energy Optimising
14 – 5* Environment

- l. Press **OK**, the following display appears -

14-50 RFI Filter [1] On
----------------------------

- m. Press **OK** to highlight the number in the bracket and use the ▲ and ▼ (Up and Down Arrow) keys to select [0]. Press **OK** again to set the selected value.

## 13. To Complete Reprogramming:

- a. Press the **Auto On** key before disconnecting the VFD Remote Keypad from the variable frequency drive.

**Table 16 – VFD Unit Parameters - 50LC Size 14**

Voltage	Unit Size	Motor Option	Motor P/N	VFD Carrier P/N	VFD Mir P/N	Regional Settings	Grid Type	Motor Power	Motor Voltage	Motor Frequency (Hz)	Motor Current (Must-Hold Amps)	Motor Nominal Speed (rpm)	Star Delay (Sec)	Flying Start	Min Speed for Function (Hz)	Motor Thermal Protection	Preset Reference		
																	3-10 [0]	3-10 [1]	3-10 [2]
208/230V	14	STD	HD58FE654	HK30WA371	131L9796	[1]	[102]	[10]	230	60	9.2	1735	2.0	[1]	1.0	[4]	0%	53.43%	79.57%
460V	14	STD	HD58FE654	HK30WA377	131L9864	[1]	[122]	[10]	460	60	4.2	1735	2.0	[1]	1.0	[4]	0%	53.43%	79.57%
575V	14	STD	HD58FE577	HK30WA383	131N0227	[1]	[132]	[11]	575	60	4.9	1710	2.0	[1]	1.0	[4]	0%	53.43%	79.57%
208/230V	14	MID	HD60FK658	HK30WA372	131L9797	[1]	[102]	[13]	230	60	13.6	1745	2.0	[1]	1.0	[4]	0%	53.43%	79.57%
460V	14	MID	HD60FK658	HK30WA379	131L9866	[1]	[122]	[13]	460	60	6.8	1745	2.0	[1]	1.0	[4]	0%	53.43%	79.57%
575V	14	MID	HD60FE576	HK30WA387	134F0217	[1]	[132]	[13]	575	60	6.0	1745	2.0	[1]	1.0	[4]	0%	53.43%	79.57%
208/230V	14	HIGH	HD60FK657	HK30WA373	131L9798	[1]	[102]	[14]	230	60	21.2	1760	2.0	[1]	1.0	[4]	0%	53.43%	79.57%
460V	14	HIGH	HD60FK657	HK30WA380	131L9867	[1]	[122]	[14]	460	60	9.7	1760	2.0	[1]	1.0	[4]	0%	53.43%	79.57%
575V	14	HIGH	HD60FL576	HK30WA384	131N0229	[1]	[132]	[14]	575	60	7.2	1745	2.0	[1]	1.0	[4]	0%	53.43%	79.57%
208/230V	14	ULTRA	HD62FK654	HK30WA374	131L9799	[1]	[102]	[15]	230	60	28.0	1760	2.0	[1]	1.0	[4]	0%	53.43%	79.57%
460V	14	ULTRA	HD62FK654	HK30WA381	131L9868	[1]	[122]	[15]	460	60	13.7	1760	2.0	[1]	1.0	[4]	0%	53.43%	79.57%
575V	14	ULTRA	HD62FL576	HK30WA384	131N0229	[1]	[132]	[15]	575	60	8.9	1750	2.0	[1]	1.0	[4]	0%	53.43%	79.57%

Voltage	Unit Size	Motor Option	Preset Reference (cont)							Ramp Down Time (Sec)	Current Limit	Terminal 18 Digital Input	Terminal 19 Digital Input	Terminal 27 Digital Input	Terminal 29 Digital Input	Terminal 53 Low Voltage	Terminal 53 High Voltage	Terminal 53 Low Reference	Terminal 53 High Reference	Reset Mode	Auto. Restart Time (S)	RFI Filter
			3-10 [3]	3-10 [4]	3-10 [5]	3-10 [6]	3-10 [7]															
208/230V	14	STD	100%	100%	0%	0%	0%	0%	10.00	100%	[8]	[16]	[17]	[18]	2	[10]	[10]	0	[60]	[3]	600	[0]
460V	14	STD	100%	100%	0%	0%	0%	10.00	100%	[8]	[16]	[17]	[18]	2	[10]	[10]	0	[60]	[3]	600	[0]	[0]
575V	14	STD	100%	100%	0%	0%	0%	10.00	100%	[8]	[16]	[17]	[18]	2	[10]	[10]	0	[60]	[3]	600	[0]	[0]
208/230V	14	MID	100%	100%	0%	0%	0%	10.00	100%	[8]	[16]	[17]	[18]	2	[10]	[10]	0	[60]	[3]	600	[0]	[0]
460V	14	MID	100%	100%	0%	0%	0%	10.00	100%	[8]	[16]	[17]	[18]	2	[10]	[10]	0	[60]	[3]	600	[0]	[0]
575V	14	MID	100%	100%	0%	0%	0%	10.00	100%	[8]	[16]	[17]	[18]	2	[10]	[10]	0	[60]	[3]	600	[0]	[0]
208/230V	14	HIGH	100%	100%	0%	0%	0%	10.00	100%	[8]	[16]	[17]	[18]	2	[10]	[10]	0	[60]	[3]	600	[0]	[0]
460V	14	HIGH	100%	100%	0%	0%	0%	10.00	100%	[8]	[16]	[17]	[18]	2	[10]	[10]	0	[60]	[3]	600	[0]	[0]
575V	14	HIGH	100%	100%	0%	0%	0%	10.00	100%	[8]	[16]	[17]	[18]	2	[10]	[10]	0	[60]	[3]	600	[0]	[0]
208/230V	14	ULTRA	100%	100%	0%	0%	0%	10.00	100%	[8]	[16]	[17]	[18]	2	[10]	[10]	0	[60]	[3]	600	[0]	[0]
460V	14	ULTRA	100%	100%	0%	0%	0%	10.00	100%	[8]	[16]	[17]	[18]	2	[10]	[10]	0	[60]	[3]	600	[0]	[0]
575V	14	ULTRA	100%	100%	0%	0%	0%	10.00	100%	[8]	[16]	[17]	[18]	2	[10]	[10]	0	[60]	[3]	600	[0]	[0]

**Table 17 – VFD Unit Parameters - 50LC Size 17**

Voltage	Unit Size	Motor Option	Motor P/N	VFD Carrier P/N	VFD Mfr P/N	Regional Settings	Grid Type	Motor Power	Motor Voltage	Motor Frequency (Hz)	Motor Current (Must-Hold Amps)	Motor Nominal Speed (rpm)	Star Delay (Sec)	Flying Start	Min Speed for Function (Hz)	Motor Thermal Protection	Preset Reference		
																	3-10 [0]	3-10 [1]	3-10 [2]
208/230V	17	STD	HD58FE654	HK30WA371	131L9796	0-03	0-06	1-20	1-22	1-23	1-24	1-25	1-71	1-73	1-82	1-90	3-10 [0]	3-10 [1]	3-10 [2]
						[1]	[102]	[10]	230	60	9.2	1735	2.0	[1]	1.0	[4]	0%	56.64%	82.40%
460V	17	STD	HD58FE654	HK30WA377	131L9864	[1]	[122]	[10]	460	60	4.2	1735	2.0	[1]	1.0	[4]	0%	56.64%	82.40%
575V	17	STD	HD58FE577	HK30WA383	131N0227	[1]	[132]	[11]	575	60	4.9	1710	2.0	[1]	1.0	[4]	0%	56.64%	82.40%
208/230V	17	MID	HD60FK657	HK30WA373	131L9798	[1]	[102]	[14]	230	60	21.2	1760	2.0	[1]	1.0	[4]	0%	56.64%	82.40%
460V	17	MID	HD60FK657	HK30WA380	131L9867	[1]	[122]	[14]	460	60	9.7	1760	2.0	[1]	1.0	[4]	0%	56.64%	82.40%
575V	17	MID	HD60FL576	HK30WA384	131N0229	[1]	[132]	[14]	575	60	7.2	1745	2.0	[1]	1.0	[4]	0%	56.64%	82.40%
208/230V	17	HIGH	HD62FK654	HK30WA374	131L9799	[1]	[102]	[15]	230	60	28.0	1760	2.0	[1]	1.0	[4]	0%	56.64%	82.40%
460V	17	HIGH	HD62FK654	HK30WA381	131L9868	[1]	[122]	[15]	460	60	13.7	1760	2.0	[1]	1.0	[4]	0%	56.64%	82.40%
575V	17	HIGH	HD62FL576	HK30WA384	131N0229	[1]	[132]	[15]	575	60	8.9	1750	2.0	[1]	1.0	[4]	0%	56.64%	82.40%
208/230V	17	ULTRA	HD64FK654	HK30WA375	131L9800	[1]	[102]	[16]	230	60	37.3	1755	2.0	[1]	1.0	[4]	0%	56.64%	82.40%
460V	17	ULTRA	HD64FK654	HK30WA386	131L9869	[1]	[122]	[16]	460	60	16.9	1755	2.0	[1]	1.0	[4]	0%	56.64%	82.40%
575V	17	ULTRA	HD64FL576	HK30WA388	131N0233	[1]	[132]	[16]	575	60	12.6	1755	2.0	[1]	1.0	[4]	0%	56.64%	82.40%

Voltage	Unit Size	Motor Option	Preset Reference (cont)							Terminal 53 High Voltage	Terminal 53 Low Voltage	Terminal 53 High Reference	Terminal 53 Low Reference	Reset Mode	Auto. Restart Time (S)	RFI Filter					
			3-10 [3]	3-10 [4]	3-10 [5]	3-10 [6]	3-10 [7]	Ramp Up Time (Sec)	Ramp Down Time (Sec)								Current Limit	Terminal 18 Digital Input	Terminal 19 Digital Input	Terminal 27 Digital Input	Terminal 29 Digital Input
208/230V	17	STD	100%	100%	0%	0%	0%	10.00	3-42	4-18	5-10	5-11	5-12	5-13	6-10	6-11	6-14	6-15	14-20	14-21	14-50
460V	17	STD	100%	100%	0%	0%	10.00	10.00	100%	8	8	16	17	18	2	10	0	60	3	600	0
575V	17	STD	100%	100%	0%	0%	10.00	10.00	100%	8	8	16	17	18	2	10	0	60	3	600	0
208/230V	17	MID	100%	100%	0%	0%	10.00	10.00	100%	8	8	16	17	18	2	10	0	60	3	600	0
460V	17	MID	100%	100%	0%	0%	10.00	10.00	100%	8	8	16	17	18	2	10	0	60	3	600	0
575V	17	MID	100%	100%	0%	0%	10.00	10.00	100%	8	8	16	17	18	2	10	0	60	3	600	0
208/230V	17	HIGH	100%	100%	0%	0%	10.00	10.00	100%	8	8	16	17	18	2	10	0	60	3	600	0
460V	17	HIGH	100%	100%	0%	0%	10.00	10.00	100%	8	8	16	17	18	2	10	0	60	3	600	0
575V	17	HIGH	100%	100%	0%	0%	10.00	10.00	100%	8	8	16	17	18	2	10	0	60	3	600	0
208/230V	17	ULTRA	100%	100%	0%	0%	10.00	10.00	100%	8	8	16	17	18	2	10	0	60	3	600	0
460V	17	ULTRA	100%	100%	0%	0%	10.00	10.00	100%	8	8	16	17	18	2	10	0	60	3	600	0
575V	17	ULTRA	100%	100%	0%	0%	10.00	10.00	100%	8	8	16	17	18	2	10	0	60	3	600	0

**Table 18 – VFD Unit Parameters - 50LC Size 20**

Voltage	Unit Size	Motor Option	Motor P/N	VFD Carrier P/N	VFD Mir P/N	Regional Settings	Grid Type	Motor Power	Motor Voltage	Motor Frequency (Hz)	Motor Current (Must-Hold Amps)	Motor Nominal Speed (rpm)	Star Delay (Sec)	Flying Start	Min Speed for Function (Hz)	Motor Thermal Protection	Preset Reference		
																	3-10 [0]	3-10 [1]	3-10 [2]
208/230V	20	STD	HD60FE656	HK30WA372	131L9797	0-03	0-06	1-20	1-22	1-23	1-24	1-25	1-71	1-73	1-82	1-90	3-10 [0]	3-10 [1]	3-10 [2]
						[1]	[102]	[11]	230	60	11.7	1750	2.0	[1]	1.0	[4]	0%	52.57%	61.63%
460V	20	STD	HD60FE656	HK30WA378	131L9865	[1]	[122]	[11]	460	60	5.4	1750	2.0	[1]	1.0	[4]	0%	52.57%	61.63%
575V	20	STD	HD58FE577	HK30WA383	131N0227	[1]	[132]	[11]	575	60	4.9	1710	2.0	[1]	1.0	[4]	0%	52.57%	61.63%
208/230V	20	MID	HD60FK657	HK30WA373	131L9798	[1]	[102]	[14]	230	60	21.2	1760	2.0	[1]	1.0	[4]	0%	52.57%	61.63%
460V	20	MID	HD60FK657	HK30WA380	131L9867	[1]	[122]	[14]	460	60	9.7	1760	2.0	[1]	1.0	[4]	0%	52.57%	61.63%
575V	20	MID	HD60FL576	HK30WA384	131N0229	[1]	[132]	[14]	575	60	7.2	1745	2.0	[1]	1.0	[4]	0%	52.57%	61.63%
208/230V	20	HIGH	HD62FK654	HK30WA374	131L9799	[1]	[102]	[15]	230	60	28.0	1760	2.0	[1]	1.0	[4]	0%	52.57%	61.63%
460V	20	HIGH	HD62FK654	HK30WA381	131L9868	[1]	[122]	[15]	460	60	13.7	1760	2.0	[1]	1.0	[4]	0%	52.57%	61.63%
575V	20	HIGH	HD62FL576	HK30WA384	131N0229	[1]	[132]	[15]	575	60	8.9	1750	2.0	[1]	1.0	[4]	0%	52.57%	61.63%
208/230V	20	ULTRA	HD64FK654	HK30WA375	131L9800	[1]	[102]	[16]	230	60	37.3	1755	2.0	[1]	1.0	[4]	0%	52.57%	61.63%
460V	20	ULTRA	HD64FK654	HK30WA386	131L9869	[1]	[122]	[16]	460	60	16.9	1755	2.0	[1]	1.0	[4]	0%	52.57%	61.63%
575V	20	ULTRA	HD64FL576	HK30WA388	131N0233	[1]	[132]	[16]	575	60	12.6	1755	2.0	[1]	1.0	[4]	0%	52.57%	61.63%

Voltage	Unit Size	Motor Option	Preset Reference (cont)							Ramp Down Time (Sec)	Current Limit	Terminal 18 Digital Input	Terminal 19 Digital Input	Terminal 27 Digital Input	Terminal 29 Digital Input	Terminal 53 Low Voltage	Terminal 53 High Voltage	Terminal 53 Low Reference	Terminal 53 High Reference	Reset Mode	Auto. Restart Time (S)	RFI Filter
			3-10 [3]	3-10 [4]	3-10 [5]	3-10 [6]	3-10 [7]															
208/230V	20	STD	100%	100%	0%	0%	0%	10.00	3-42	100%	8	5-11	5-12	5-13	6-10	6-11	6-14	6-15	14-20	14-21	14-50	[0]
460V	20	STD	100%	100%	0%	0%	10.00	10.00	10.00	100%	8	[16]	[17]	[18]	2	[10]	0	[60]	[3]	600	600	[0]
575V	20	STD	100%	100%	0%	0%	10.00	10.00	10.00	100%	8	[16]	[17]	[18]	2	[10]	0	[60]	[3]	600	600	[0]
208/230V	20	MID	100%	100%	0%	0%	10.00	10.00	10.00	100%	8	[16]	[17]	[18]	2	[10]	0	[60]	[3]	600	600	[0]
460V	20	MID	100%	100%	0%	0%	10.00	10.00	10.00	100%	8	[16]	[17]	[18]	2	[10]	0	[60]	[3]	600	600	[0]
575V	20	MID	100%	100%	0%	0%	10.00	10.00	10.00	100%	8	[16]	[17]	[18]	2	[10]	0	[60]	[3]	600	600	[0]
208/230V	20	HIGH	100%	100%	0%	0%	10.00	10.00	10.00	100%	8	[16]	[17]	[18]	2	[10]	0	[60]	[3]	600	600	[0]
460V	20	HIGH	100%	100%	0%	0%	10.00	10.00	10.00	100%	8	[16]	[17]	[18]	2	[10]	0	[60]	[3]	600	600	[0]
575V	20	HIGH	100%	100%	0%	0%	10.00	10.00	10.00	100%	8	[16]	[17]	[18]	2	[10]	0	[60]	[3]	600	600	[0]
208/230V	20	ULTRA	100%	100%	0%	0%	10.00	10.00	10.00	100%	8	[16]	[17]	[18]	2	[10]	0	[60]	[3]	600	600	[0]
460V	20	ULTRA	100%	100%	0%	0%	10.00	10.00	10.00	100%	8	[16]	[17]	[18]	2	[10]	0	[60]	[3]	600	600	[0]
575V	20	ULTRA	100%	100%	0%	0%	10.00	10.00	10.00	100%	8	[16]	[17]	[18]	2	[10]	0	[60]	[3]	600	600	[0]

**Table 19 – VFD Unit Parameters - 50LC Size 24**

Voltage	Unit Size	Motor Option	Motor P/N	VFD Carrier P/N	VFD Mfr P/N	Regional Settings	Grid Type	Motor Power	Motor Voltage	Motor Frequency (Hz)	Motor Current (Must-Hold Amps)	Motor Nominal Speed (rpm)	Star Delay (Sec)	Flying Start	Min Speed for Function (Hz)	Motor Thermal Protection	Preset Reference		
																	3-10 [0]	3-10 [1]	3-10 [2]
208/230V	24	STD	HD60FK657	HK30WA373	131L9798	0-03	0-06	1-20	1-22	1-23	1-24	1-25	1-71	1-73	1-82	1-90	3-10 [0]	3-10 [1]	3-10 [2]
						[1]	[102]	[14]	230	60	21.2	1760	2.0	[1]	1.0	[4]	0%	52.33%	64.48%
460V	24	STD	HD60FK657	HK30WA380	131L9867	[1]	[122]	[14]	460	60	9.7	1760	2.0	[1]	1.0	[4]	0%	52.33%	64.48%
575V	24	STD	HD60FL576	HK30WA384	131N0229	[1]	[132]	[14]	575	60	7.2	1745	2.0	[1]	1.0	[4]	0%	52.33%	64.48%
208/230V	24	MID	HD60FK657	HK30WA373	131L9798	[1]	[102]	[14]	230	60	21.2	1760	2.0	[1]	1.0	[4]	0%	52.33%	64.48%
						[1]	[122]	[14]	460	60	9.7	1760	2.0	[1]	1.0	[4]	0%	52.33%	64.48%
460V	24	MID	HD60FL576	HK30WA384	131N0229	[1]	[132]	[14]	575	60	7.2	1745	2.0	[1]	1.0	[4]	0%	52.33%	64.48%
208/230V	24	HIGH	HD62FK654	HK30WA374	131L9799	[1]	[102]	[15]	230	60	28.0	1760	2.0	[1]	1.0	[4]	0%	52.33%	64.48%
						[1]	[122]	[15]	460	60	13.7	1760	2.0	[1]	1.0	[4]	0%	52.33%	64.48%
460V	24	HIGH	HD62FL576	HK30WA384	131N0229	[1]	[132]	[15]	575	60	8.9	1750	2.0	[1]	1.0	[4]	0%	52.33%	64.48%
208/230V	24	ULTRA	HD64FK654	HK30WA375	131L9800	[1]	[102]	[16]	230	60	37.3	1755	2.0	[1]	1.0	[4]	0%	52.33%	64.48%
						[1]	[122]	[16]	460	60	16.9	1755	2.0	[1]	1.0	[4]	0%	52.33%	64.48%
460V	24	ULTRA	HD64FL576	HK30WA386	131L9869	[1]	[132]	[16]	575	60	12.6	1755	2.0	[1]	1.0	[4]	0%	52.33%	64.48%

Voltage	Unit Size	Motor Option	Preset Reference (cont)							Ramp Down Time (Sec)	Current Limit	Terminal 18 Digital Input	Terminal 19 Digital Input	Terminal 27 Digital Input	Terminal 29 Digital Input	Terminal 53 Low Voltage	Terminal 53 High Voltage	Terminal 53 Low Reference	Terminal 53 High Reference	Reset Mode	Auto. Restart Time (S)	RFI Filter
			3-10 [3]	3-10 [4]	3-10 [5]	3-10 [6]	3-10 [7]	3-41	3-42													
208/230V	24	STD	100%	100%	0%	0%	0%	0%	10.00	100%	[8]	[16]	[17]	[18]	2	[10]	[60]	0	[60]	[3]	600	[0]
460V	24	STD	100%	100%	0%	0%	0%	10.00	100%	[8]	[16]	[17]	[18]	2	[10]	[60]	0	[60]	[3]	600	[0]	
575V	24	STD	100%	100%	0%	0%	0%	10.00	100%	[8]	[16]	[17]	[18]	2	[10]	[60]	0	[60]	[3]	600	[0]	
208/230V	24	MID	100%	100%	0%	0%	0%	10.00	100%	[8]	[16]	[17]	[18]	2	[10]	[60]	0	[60]	[3]	600	[0]	
460V	24	MID	100%	100%	0%	0%	0%	10.00	100%	[8]	[16]	[17]	[18]	2	[10]	[60]	0	[60]	[3]	600	[0]	
575V	24	MID	100%	100%	0%	0%	0%	10.00	100%	[8]	[16]	[17]	[18]	2	[10]	[60]	0	[60]	[3]	600	[0]	
208/230V	24	HIGH	100%	100%	0%	0%	0%	10.00	100%	[8]	[16]	[17]	[18]	2	[10]	[60]	0	[60]	[3]	600	[0]	
460V	24	HIGH	100%	100%	0%	0%	0%	10.00	100%	[8]	[16]	[17]	[18]	2	[10]	[60]	0	[60]	[3]	600	[0]	
575V	24	HIGH	100%	100%	0%	0%	0%	10.00	100%	[8]	[16]	[17]	[18]	2	[10]	[60]	0	[60]	[3]	600	[0]	
208/230V	24	ULTRA	100%	100%	0%	0%	0%	10.00	100%	[8]	[16]	[17]	[18]	2	[10]	[60]	0	[60]	[3]	600	[0]	
460V	24	ULTRA	100%	100%	0%	0%	0%	10.00	100%	[8]	[16]	[17]	[18]	2	[10]	[60]	0	[60]	[3]	600	[0]	
575V	24	ULTRA	100%	100%	0%	0%	0%	10.00	100%	[8]	[16]	[17]	[18]	2	[10]	[60]	0	[60]	[3]	600	[0]	

**Table 20 – VFD Unit Parameters - 50LC Size 26**

Voltage	Unit Size	Motor Option	Regional Settings		Grid Type	Motor Power	Motor Voltage	Motor Frequency (Hz)	Motor Current (Must-Hold Amps)	Motor Nominal Speed (rpm)	Star Delay (Sec)	Flying Start	Min Speed for Function (Hz)	Motor Thermal Protection	Preset Reference		
			VFD Carrier P/N	VFD Mfr P/N											3-10 [0]	3-10 [1]	3-10 [2]
208/230V	26	STD	HK30WA373	131L9798	[102]	[14]	230	60	21.2	1760	2.0	[1]	1.0	[4]	0%	60.00%	72.00%
460V	26	STD	HK30WA380	131L9867	[122]	[14]	460	60	9.7	1760	2.0	[1]	1.0	[4]	0%	60.00%	72.00%
575V	26	STD	HK30WA384	131N0229	[132]	[14]	575	60	7.2	1745	2.0	[1]	1.0	[4]	0%	60.00%	72.00%
208/230V	26	MID	HK30WA374	131L9799	[102]	[15]	230	60	28.0	1760	2.0	[1]	1.0	[4]	0%	60.00%	72.00%
460V	26	MID	HK30WA381	131L9868	[122]	[15]	460	60	13.7	1760	2.0	[1]	1.0	[4]	0%	60.00%	72.00%
575V	26	MID	HK30WA384	131N0229	[132]	[15]	575	60	8.9	1750	2.0	[1]	1.0	[4]	0%	60.00%	72.00%
208/230V	26	HIGH	HK30WA375	131L9800	[102]	[16]	230	60	37.3	1755	2.0	[1]	1.0	[4]	0%	60.00%	72.00%
460V	26	HIGH	HK30WA386	131L9869	[122]	[16]	460	60	16.9	1755	2.0	[1]	1.0	[4]	0%	60.00%	72.00%
575V	26	HIGH	HK30WA388	131N0233	[132]	[16]	575	60	12.6	1755	2.0	[1]	1.0	[4]	0%	60.00%	72.00%

Voltage	Unit Size	Motor Option	Preset Reference (cont)							Ramp Up Time (Sec)	Ramp Down Time (Sec)	Current Limit	Terminal 18 Digital Input	Terminal 19 Digital Input	Terminal 27 Digital Input	Terminal 29 Digital Input	Terminal 53 Low Voltage	Terminal 53 High Voltage	Terminal 53 Low Reference	Terminal 53 High Reference	Reset Mode	Auto. Restart Time (S)	RFI Filter
			3-10 [3]	3-10 [4]	3-10 [5]	3-10 [6]	3-10 [7]																
208/230V	26	STD	100%	100%	0%	0%	0%	10.00	3-42	4-18	5-10	5-11	5-12	5-13	6-10	6-11	6-14	6-15	14-20	14-21	14-50	[0]	
460V	26	STD	100%	100%	0%	0%	0%	10.00	10.00	100%	[8]	[16]	[17]	[18]	2	[10]	0	[60]	[60]	[3]	600	[0]	
575V	26	STD	100%	100%	0%	0%	0%	10.00	10.00	100%	[8]	[16]	[17]	[18]	2	[10]	0	[60]	[60]	[3]	600	[0]	
208/230V	26	MID	100%	100%	0%	0%	0%	10.00	10.00	100%	[8]	[16]	[17]	[18]	2	[10]	0	[60]	[60]	[3]	600	[0]	
460V	26	MID	100%	100%	0%	0%	0%	10.00	10.00	100%	[8]	[16]	[17]	[18]	2	[10]	0	[60]	[60]	[3]	600	[0]	
575V	26	MID	100%	100%	0%	0%	0%	10.00	10.00	100%	[8]	[16]	[17]	[18]	2	[10]	0	[60]	[60]	[3]	600	[0]	
208/230V	26	HIGH	100%	100%	0%	0%	0%	10.00	10.00	100%	[8]	[16]	[17]	[18]	2	[10]	0	[60]	[60]	[3]	600	[0]	
460V	26	HIGH	100%	100%	0%	0%	0%	10.00	10.00	100%	[8]	[16]	[17]	[18]	2	[10]	0	[60]	[60]	[3]	600	[0]	
575V	26	HIGH	100%	100%	0%	0%	0%	10.00	10.00	100%	[8]	[16]	[17]	[18]	2	[10]	0	[60]	[60]	[3]	600	[0]	



**Table 21 – Unit Wire/Fuse or HACR Breaker Sizing Data**

UNIT	NO M. V.-Ph-HZ	ELEC. HTR				NO C.O. or UNPWR C.O.										w/ PWRD C.O.									
		CRHEATER™ A00 VERT/HORZ	Nom (kW)	FLA	MCA	NO P.E.			w/ P.E. (pwrd ft/unit)			NO P.E.			w/ P.E. (pwrd ft/unit)			NO P.E.			w/ P.E. (pwrd ft/unit)				
						MAX FUSE or HACR BRKR	FLA	LIRA	MCA	MAX FUSE or HACR BRKR	FLA	LIRA	MCA	MAX FUSE or HACR BRKR	FLA	LIRA	MCA	MAX FUSE or HACR BRKR	FLA	LIRA	MCA	MAX FUSE or HACR BRKR	FLA	LIRA	MCA
STD		NONE	-	-	-	59.158.3	8080	61/60	343	70.970.1	90/90	75/74	363	63.9/63.1	8080	67/66	348	75.7/74.9	90/90	67/66	348	75.7/74.9	90/90	80/79	368
		302/306A00	11.3/15.0	31.3/36.1	59.158.3	8080	61/60	343/343	70.970.1	90/90	75/74	363/363	63.9/63.1	8080	67/66	348/348	75.7/75.6	90/90	67/66	348/348	75.7/75.6	90/90	80/79	368/368	
		279/270A00	18.8/25.0	52.1/60.1	75.9/84.9	8090	70/78	343/343	90.6/99.6	100/100	83/92	363/363	81.9/90.9	90/100	135/153	348/348	96.6/105.6	100/110	149/166	161.8/150.8	175/175	149/166	161.8/150.8	175/175	368/368
		309/312A00	37.6/50.0	104.2/120.3	141.0/130.1	150/150	130/147	343/343	155.8/144.8	175/150	143/161	363/363	147.0/136.1	150/150	135/153	348/348	161.8/150.8	175/175	149/166	161.8/150.8	175/175	149/166	161.8/150.8	175/175	368/368
MED		NONE	-	-	-	64.1/63.2	8080	67/66	378	75.975.0	90/90	81/80	398	68.9/68.0	90/90	73/72	383	80.7/79.8	100/100	86/85	383	80.7/79.8	100/100	86/85	403
		302/306A00	11.3/15.0	31.3/36.1	64.1/63.2	8080	67/66	378/378	75.975.8	90/90	81/80	398/398	68.9/68.0	90/90	73/72	383/383	80.7/81.8	100/100	86/85	383/383	80.7/81.8	100/100	86/85	403/403	
		279/270A00	18.8/25.0	52.1/60.1	82.1/91.0	90/100	76/84	378/378	96.9/105.8	100/110	89/97	398/398	88.1/97.0	90/100	141/158	383/383	102.9/111.8	110/125	95/103	383/383	102.9/111.8	110/125	95/103	403/403	
		309/312A00	37.6/50.0	104.2/120.3	147.3/136.2	150/150	135/153	378/378	162.0/150.9	175/175	149/167	398/398	153.3/142.2	175/175	150/168	387/387	168.0/156.9	200/175	155/172	387/387	168.0/156.9	200/175	155/172	403/403	
HIGH		NONE	-	-	-	71.7	90	76	382	83.5	100	89	402	76.5	90	81	387	88.3	100	95	387	88.3	100	95	407
		302/306A00	11.3/15.0	31.3/36.1	71.7/71.7	90/90	76/76	382/382	83.5/86.4	100/100	89/89	402/402	76.5/77.6	90/90	81/81	387/387	88.3/92.4	100/100	95/95	387/387	88.3/92.4	100/100	95/95	407/407	
		279/270A00	18.8/25.0	52.1/60.1	91.6/101.6	100/110	84/93	382/382	106.4/116.4	110/125	98/107	402/402	97.6/107.6	100/110	90/99	387/387	112.4/122.4	125/125	103/113	387/387	112.4/122.4	125/125	103/113	407/407	
		309/312A00	37.6/50.0	104.2/120.3	156.8/146.8	175/175	144/163	382/382	171.5/161.6	175/175	158/176	402/402	162.8/152.8	175/175	150/168	387/387	177.5/167.6	200/175	163/182	387/387	177.5/167.6	200/175	163/182	407/407	
ULTRA		NONE	-	-	-	79.7	100	84	456	91.5	100	97	476	84.5	100	89	461	96.3	110	103	461	96.3	110	103	481
		302/306A00	11.3/15.0	31.3/36.1	79.7/80.1	100/100	84/84	456/456	91.5/94.9	100/100	97/97	476/476	84.5/86.1	100/100	89/89	461/461	96.3/100.9	110/110	103/103	461/461	96.3/100.9	110/110	103/103	481/481	
		279/270A00	18.8/25.0	52.1/60.1	100.1/110.1	110/125	92/101	456/456	114.9/124.9	125/125	106/115	476/476	106.1/116.1	110/125	98/107	461/461	120.9/130.9	125/150	111/120	461/461	120.9/130.9	125/150	111/120	481/481	
		309/312A00	37.6/50.0	104.2/120.3	165.3/155.3	175/175	152/171	456/456	180.0/170.1	200/175	166/184	476/476	171.3/161.3	175/175	158/176	461/461	186.0/176.1	200/200	171/190	461/461	186.0/176.1	200/200	171/190	481/481	
STD		NONE	-	-	-	31.3	40	33	167	37.5	45	40	179	33.5	40	35	169	39.7	50	42	169	39.7	50	42	181
		303/306A00	15.0	18.0	31.3	40	33	167	37.5	45	40	179	33.5	40	35	169	39.7	50	42	169	39.7	50	42	181	
		282/273A00	25.0	30.1	42.4	45	39	167	50.1	60	46	179	45.1	50	42	169	52.9	60	49	169	52.9	60	49	181	
		310/313A00	50.0	60.1	64.9	70	73	167	72.6	80	81	179	67.6	80	76	169	75.4	80	83	169	75.4	80	83	181	
MED		NONE	-	-	-	33.9	45	36	184	40.1	50	43	196	36.1	45	38	186	42.3	50	45	186	42.3	50	45	198
		303/306A00	15.0	18.0	33.9	45	36	184	40.1	50	43	196	36.1	45	38	186	42.3	50	45	186	42.3	50	45	198	
		282/273A00	25.0	30.1	45.6	50	42	184	53.4	60	49	196	48.4	50	45	186	56.1	60	52	186	56.1	60	52	198	
		310/313A00	50.0	60.1	68.1	80	76	184	75.9	80	84	196	70.9	80	79	186	78.6	80	86	186	78.6	80	86	198	
HIGH		NONE	-	-	-	37.2	45	40	186	43.4	50	47	198	39.4	50	42	188	45.6	50	49	188	45.6	50	49	200
		303/306A00	15.0	18.0	37.2	45	40	186	43.4	50	47	198	39.4	50	42	188	45.6	50	49	188	45.6	50	49	200	
		282/273A00	25.0	30.1	49.8	50	46	186	57.5	60	53	198	52.5	60	48	188	60.3	70	55	188	60.3	70	55	200	
		310/313A00	50.0	60.1	72.2	80	80	186	80.0	90	87	198	75.0	80	83	188	82.7	90	90	188	82.7	90	90	200	
ULTRA		NONE	-	-	-	41.8	50	44	223	48.0	60	51	235	44.0	50	47	225	50.2	60	54	225	50.2	60	54	237
		303/306A00	15.0	18.0	41.8	50	44	223	48.0	60	51	235	44.0	50	47	225	50.2	60	54	225	50.2	60	54	237	
		282/273A00	25.0	30.1	54.8	60	50	223	62.5	70	58	235	57.5	60	53	225	65.3	70	60	225	65.3	70	60	237	
		310/313A00	50.0	60.1	77.2	90	85	223	85.0	90	92	235	80.0	90	87	225	87.7	90	95	225	87.7	90	95	237	

See "Legend and Notes for Tables 21 and 22" on page 92.

**Table 21 - Unit Wire/Fuse or HACR Breaker Sizing Data (cont)**

UNIT	NO M.V.-Ph-HZ	ELEC. HTR			NO C.O. or UNPWR C.O.															
		CRHEATER-A00 VERT/HORZ	Nom (kW)	FLA	NO P.E.				w/ P.E. (pwrd ft/unit)				NO P.E.				w/ P.E. (pwrd ft/unit)			
					MAX FUSE or HACR BRKR	DISC. SIZE FLA	LRA	MCA	MAX FUSE or HACR BRKR	DISC. SIZE FLA	LRA	MCA	MAX FUSE or HACR BRKR	DISC. SIZE FLA	LRA	MCA	MAX FUSE or HACR BRKR	DISC. SIZE FLA	LRA	MCA
STD		NONE	-	-	26	119	29.2	35	31	127	26.1	30	28	121	30.9	35	33	129		
		304/307A00	15.0	14.4	26	119	29.6	35	31	127	26.1	30	28	121	31.8	35	33	129		
		285/276A00	24.8	23.9	33	119	41.5	45	38	127	37.6	40	35	121	43.6	45	40	129		
		311/314A00	49.6	47.7	60	119	71.3	80	66	127	67.4	70	62	121	73.4	80	68	129		
MED		NONE	-	-	28	133	30.9	35	33	141	27.8	30	30	135	32.6	40	35	143		
		304/307A00	15.0	14.4	28	133	31.8	35	33	141	27.9	30	30	135	33.9	40	35	143		
		285/276A00	24.8	23.9	35	133	43.6	45	40	141	39.8	40	37	135	45.8	50	42	143		
		311/314A00	49.6	47.7	62	133	73.4	80	68	141	69.5	70	64	135	75.5	80	69	143		
HIGH		NONE	-	-	29	131	31.9	35	34	139	28.8	35	31	133	33.6	40	36	141		
		304/307A00	15.0	14.4	29	131	33.0	35	34	139	29.1	35	31	133	35.1	40	36	141		
		285/276A00	24.8	23.9	36	131	44.9	45	41	139	41.0	45	38	133	47.0	50	43	141		
		311/314A00	49.6	47.7	63	131	74.6	80	69	139	70.8	80	65	133	76.8	80	71	141		
ULTRA		NONE	-	-	31	158	33.8	40	36	166	30.7	35	33	160	35.5	40	38	168		
		304/307A00	15.0	14.4	31	158	35.1	40	36	166	31.3	35	33	160	37.3	40	38	168		
		285/276A00	24.8	23.9	38	158	47.0	50	43	166	43.1	45	40	160	49.1	50	45	168		
		311/314A00	49.6	47.7	65	158	76.8	80	71	166	72.9	80	67	160	78.9	80	73	168		

See "Legend and Notes for Tables 21 and 22" on page 92.

**Table 21 - Unit Wire/Fuse or HACR Breaker Sizing Data (cont)**

UNIT	NO M. V.-Ph-HZ	ELEC. HTR				NO C.O. or UNPWR C.O.										w/ PWRD C.O.									
		CRHEATER/A00 VERT/HORZ	Nom (kW)	FLA	IFM TYPE	NO P.E.				w/ P.E. (pwrd ft/unit)				NO P.E.				w/ P.E. (pwrd ft/unit)							
						MAX FUSE or HACR BRKR	DISC. SIZE FLA LRA	MCA	MAX FUSE or HACR BRKR	DISC. SIZE FLA LRA	MCA	MAX FUSE or HACR BRKR	DISC. SIZE FLA LRA	MCA	MAX FUSE or HACR BRKR	DISC. SIZE FLA LRA	MCA	MAX FUSE or HACR BRKR	DISC. SIZE FLA LRA	MCA					
STD		NONE	-	-	-	67.4/66.6	90/90	70/69	371	79.2/78.4	100/100	83/82	391	72.2/71.4	90/90	75/74	376	84.0/83.2	100/100	89/88	396				
		279/270A00	18.8/25.0	52.1/60.1		75.9/84.9	90/90	70/78	371/371	90.6/99.6	100/100	83/92	391/391	81.9/90.9	90/100	75/84	376/376	96.6/105.6	100/110	89/97	396/396				
		280/271A00	37.6/50.0	104.2/120.3		141.0/130.1	150/150	130/147	371/371	155.8/144.8	175/150	143/161	391/391	147.0/136.1	150/150	135/153	376/376	161.8/150.8	175/175	149/166	396/396				
		281/272A00	56.3/75.0	156.4/180.4		167.2/190.2	200/200	190/216	371/371	181.9/204.9	200/225	203/230	391/391	173.2/196.2	200/225	195/222	376/376	187.9/210.9	200/225	209/236	396/396				
MED		NONE	-	-	-	80.0	100	84	410	91.8	100	98	430	84.8	100	90	415	96.6	110	103	435				
		279/270A00	18.8/25.0	52.1/60.1		91.6/101.6	100/110	84/93	410/410	106.4/116.4	110/125	98/107	430/430	97.6/107.6	100/110	90/99	415/415	112.4/122.4	125/125	103/113	435/435				
		280/271A00	37.6/50.0	104.2/120.3		156.8/146.8	175/175	144/163	410/410	171.5/161.6	175/175	158/176	430/430	162.8/152.8	175/175	150/168	415/415	177.5/167.6	200/175	163/182	435/435				
		281/272A00	56.3/75.0	156.4/180.4		182.9/206.9	200/250	204/232	410/410	197.7/221.7	225/250	218/245	430/430	188.9/212.9	200/250	210/237	415/415	203.7/227.7	225/250	223/251	435/435				
HIGH		NONE	-	-	-	86.9	100	92	484	98.7	125	105	504	91.7	100	97	489	103.5	125	111	509				
		279/270A00	18.8/25.0	52.1/60.1		100.1/110.1	110/125	92/101	484/484	114.9/124.9	125/125	106/115	504/504	106.1/116.1	110/125	98/107	489/489	120.9/130.9	125/150	111/120	509/509				
		280/271A00	37.6/50.0	104.2/120.3		165.3/155.3	175/175	152/171	484/484	180.0/170.1	200/175	166/184	504/504	171.3/161.3	175/175	158/176	489/489	186.0/176.1	200/200	171/190	509/509				
		281/272A00	56.3/75.0	156.4/180.4		191.4/215.4	200/250	212/240	484/484	206.2/230.2	225/250	226/253	504/504	197.4/221.4	225/250	218/245	489/489	212.2/236.2	225/250	231/259	509/509				
ULTRA		NONE	-	-	-	98.5	125	103	524	110.3	125	116	544	103.3	125	108	529	115.1	150	122	549				
		279/270A00	18.8/25.0	52.1/60.1		111.8/121.8	125/125	103/112	524/524	126.5/136.5	150/150	116/126	544/544	117.8/127.8	125/150	108/118	529/529	132.5/142.5	150/150	122/131	549/549				
		280/271A00	37.6/50.0	104.2/120.3		176.9/166.9	200/200	163/181	524/524	191.6/181.7	200/200	176/195	544/544	182.9/172.9	200/200	168/187	529/529	197.6/187.7	200/200	182/200	549/549				
		281/272A00	56.3/75.0	156.4/180.4		203.0/227.0	225/250	223/250	524/524	217.8/241.8	250/250	236/264	544/544	209.0/233.0	225/250	228/256	529/529	223.8/247.8	250/300	242/269	549/549				
STD		NONE	-	-	-	34.8	45	36	193	41.0	50	43	205	37.0	45	39	195	43.2	50	46	207				
		282/273A00	25.0	30.1		42.4	45	39	193	50.1	60	46	205	45.1	50	42	195	52.9	60	49	207				
		283/274A00	50.0	60.1		64.9	70	73	193	72.6	80	81	205	67.6	80	76	195	75.4	80	83	207				
		284/275A00	75.0	90.2		95.0	100	108	193	102.7	110	115	205	97.7	100	111	195	105.5	110	118	207				
MED		NONE	-	-	-	40.7	50	43	212	46.9	60	50	224	42.9	50	46	214	49.1	60	53	226				
		282/273A00	25.0	30.1		49.8	50	46	212	57.5	60	53	224	52.5	60	48	214	60.3	70	55	226				
		283/274A00	50.0	60.1		72.2	80	80	212	80.0	90	87	224	75.0	80	83	214	82.7	90	90	226				
		284/275A00	75.0	90.2		102.3	125	115	212	110.1	125	122	224	105.1	125	117	214	112.8	125	125	226				
HIGH		NONE	-	-	-	44.9	50	48	249	51.1	60	55	261	47.1	60	50	251	53.3	60	57	263				
		282/273A00	25.0	30.1		54.8	60	50	249	62.5	70	58	261	57.5	60	53	251	65.3	70	60	263				
		283/274A00	50.0	60.1		77.2	90	85	249	85.0	90	92	261	80.0	90	87	251	87.7	90	95	263				
		284/275A00	75.0	90.2		107.3	125	119	249	115.1	125	127	261	110.1	125	122	251	117.8	125	129	263				
ULTRA		NONE	-	-	-	48.9	60	51	269	55.1	60	59	281	51.1	60	54	271	57.3	70	61	283				
		282/273A00	25.0	30.1		58.8	60	54	269	66.5	70	61	281	61.5	70	57	271	69.3	70	64	283				
		283/274A00	50.0	60.1		81.2	90	89	269	89.0	100	96	281	84.0	100	91	271	91.7	100	98	283				
		284/275A00	75.0	90.2		111.3	125	123	269	119.1	125	130	281	114.1	125	126	271	121.8	125	133	283				

See "Legend and Notes for Tables 21 and 22" on page 92.

**Table 21 - Unit Wire/Fuse or HACR Breaker Sizing Data (cont)**

UNIT	NOM. V-PH-HZ	IFM TYPE	ELEC. HTR		NO C.O. or UNPWR C.O.												w/ PWRD C.O.						
			CRHEATER***A00 VERT/HORZ	Nom (KW)	FLA	NO P.E.			w/ P.E. (pwrd fr/unit)			NO P.E.			w/ P.E. (pwrd fr/unit)			NO P.E.			w/ P.E. (pwrd fr/unit)		
						MCA	MAX FUSE of HACR BRKR	DISC. SIZE FLA LRA	MCA	MAX FUSE of HACR BRKR	DISC. SIZE FLA LRA	MCA	MAX FUSE of HACR BRKR	DISC. SIZE FLA LRA	MCA	MAX FUSE of HACR BRKR	DISC. SIZE FLA LRA	MCA	MAX FUSE of HACR BRKR	DISC. SIZE FLA LRA			
STD			NONE	-	-	30.0	40	32	154	162	37	40	33	156	162	31.7	40	33	156	36.5	45	39	164
			285/276A00	24.8	23.9	35.5	40	33	154	162	38	45	35	156	162	37.6	40	35	156	43.6	45	40	164
			286/277A00	49.6	47.7	65.3	70	60	154	162	66	80	62	156	162	67.4	70	62	156	73.4	80	68	164
			287/278A00	74.4	71.6	77.2	90	88	154	162	93	90	89	156	162	79.4	90	89	156	85.4	90	95	164
MED			NONE	-	-	32.7	40	35	166	174	40	45	37	168	174	34.4	40	37	168	39.2	45	42	176
			285/276A00	24.8	23.9	38.9	40	36	166	174	41	45	38	168	174	41.0	45	38	168	47.0	50	43	176
			286/277A00	49.6	47.7	68.6	70	63	166	174	69	80	65	168	174	70.8	80	65	168	76.8	80	71	176
			287/278A00	74.4	71.6	80.6	90	91	166	174	96	90	93	168	174	82.7	90	93	168	88.7	90	98	176
HIGH			NONE	-	-	34.4	40	37	193	201	42	45	39	195	201	36.1	45	39	195	40.9	50	44	203
			285/276A00	24.8	23.9	41.0	45	38	193	201	43	50	40	195	201	43.1	45	40	195	49.1	50	45	203
			286/277A00	49.6	47.7	70.8	80	65	193	201	71	80	67	195	201	72.9	80	67	195	78.9	80	73	203
			287/278A00	74.4	71.6	82.7	90	93	193	201	98	90	95	195	201	84.9	90	95	195	90.9	100	100	203
ULTRA			NONE	-	-	38.7	50	41	204	212	46	50	43	206	212	40.4	50	43	206	45.2	50	48	214
			285/276A00	24.8	23.9	45.6	50	42	204	212	47	60	44	206	212	47.8	50	44	206	53.8	60	49	214
			286/277A00	49.6	47.7	75.4	80	69	204	212	75	90	71	206	212	77.5	80	71	206	83.5	90	77	214
			287/278A00	74.4	71.6	87.4	100	97	204	212	102	100	99	206	212	89.5	100	99	206	95.5	100	104	214

See "Legend and Notes for Tables 21 and 22" on page 92.

**Table 21 - Unit Wire/Fuse or HACR Breaker Sizing Data (cont)**

UNIT	NO M. V.-Ph-HZ	ELEC. HTR				NO C.O. or UNPWR C.O.										w/ PWRD C.O.									
		CRHEATER-A00 VERT/HORZ	Nom (kW)	FLA	IFM TYPE	NO P.E.					w/ P.E. (pwrd ft/unit)					NO P.E.					w/ P.E. (pwrd ft/unit)				
						MAX FUSE or HACR BRKR	FLA	LIRA	DISC. SIZE	MCA	MAX FUSE or HACR BRKR	MCA	FLA	LIRA	DISC. SIZE	MCA	MAX FUSE or HACR BRKR	MCA	FLA	LIRA	DISC. SIZE	MCA	MAX FUSE or HACR BRKR	MCA	FLA
STD		NONE	-	-	-	73.3/72.5	100/100	76/75	412	85.1/84.3	100/100	90/89	432	78.1/77.3	100/100	82/81	417	89.9/89.1	100/100	95/95	437	437/437			
		279/270A00	18.8/25.0	52.1/60.1	-	75.9/84.9	100/100	76/78	412/412	90.6/99.6	100/100	90/92	432/432	81.9/90.9	100/100	82/84	417/417	96.6/105.6	100/110	95/97	437/437				
		280/271A00	37.6/50.0	104.2/120.3	-	141.0/130.1	150/150	130/147	412/412	155.8/144.8	175/150	143/161	432/432	147.0/136.1	150/150	135/153	417/417	161.8/150.8	175/175	149/166	437/437				
		281/272A00	56.3/75.0	156.4/180.4	-	167.2/190.2	200/200	190/216	412/412	181.9/204.9	200/225	203/230	432/432	173.2/196.2	200/225	195/222	417/417	187.9/210.9	200/225	209/236	437/437				
MED		NONE	-	-	-	85.9	100	91	451	97.7	125	104	471	90.7	100	96	456	102.5	125	110	476	476/476			
		279/270A00	18.8/25.0	52.1/60.1	-	91.6/101.6	100/110	91/93	451/451	106.4/116.4	125/125	104/107	471/471	97.6/107.6	100/110	96/99	456/456	112.4/122.4	125/125	110/113	476/476				
		280/271A00	37.6/50.0	104.2/120.3	-	156.8/146.8	175/175	144/163	451/451	171.5/161.6	175/175	158/176	471/471	162.8/152.8	175/175	150/168	456/456	177.5/167.6	200/175	163/182	476/476				
		281/272A00	56.3/75.0	156.4/180.4	-	182.9/206.9	200/250	204/232	451/451	197.7/221.7	225/250	218/245	471/471	188.9/212.9	200/250	210/237	456/456	203.7/227.7	225/250	223/251	476/476				
HIGH		NONE	-	-	-	92.8	100	99	525	104.6	125	112	545	97.6	125	104	530	109.4	125	118	550	550/550			
		279/270A00	18.8/25.0	52.1/60.1	-	100.1/110.1	110/125	99/101	525/525	114.9/124.9	125/125	112/115	545/545	106.1/116.1	125/125	104/107	530/530	120.9/130.9	125/150	118/120	550/550				
		280/271A00	37.6/50.0	104.2/120.3	-	165.3/155.3	175/175	152/171	525/525	180.0/170.1	200/175	166/184	545/545	171.3/161.3	175/175	158/176	530/530	186.0/176.1	200/200	171/190	550/550				
		281/272A00	56.3/75.0	156.4/180.4	-	191.4/215.4	200/250	212/240	525/525	206.2/230.2	225/250	226/253	545/545	197.4/221.4	225/250	218/245	530/530	212.2/236.2	225/250	231/259	550/550				
ULTRA		NONE	-	-	-	104.4	125	109	565	116.2	150	123	585	109.2	125	115	570	121.0	150	128	590	590/590			
		279/270A00	18.8/25.0	52.1/60.1	-	111.8/121.8	125/125	109/112	565/565	126.5/136.5	150/150	123/126	585/585	117.8/127.8	125/150	115/118	570/570	132.5/142.5	150/150	128/131	590/590				
		280/271A00	37.6/50.0	104.2/120.3	-	176.9/166.9	200/200	163/181	565/565	191.6/181.7	200/200	176/195	585/585	182.9/172.9	200/200	168/187	570/570	197.6/187.7	200/200	182/200	590/590				
		281/272A00	56.3/75.0	156.4/180.4	-	203.0/227.0	225/250	223/250	565/565	217.8/241.8	250/250	236/264	585/585	209.0/233.0	225/250	228/256	570/570	223.8/247.8	250/300	242/269	590/590				
STD		NONE	-	-	-	37.2	50	39	231	43.4	50	46	243	39.4	50	42	233	45.6	50	49	245	245/245			
		282/273A00	25.0	30.1	-	42.4	50	39	231	50.1	60	46	243	45.1	50	42	233	52.9	60	49	245				
		283/274A00	50.0	60.1	-	64.9	70	73	231	72.6	80	81	243	67.6	80	76	233	75.4	80	83	245				
		284/275A00	75.0	90.2	-	95.0	100	108	231	102.7	110	115	243	97.7	100	111	233	105.5	110	118	245				
MED		NONE	-	-	-	43.1	50	46	250	49.3	60	53	262	45.3	50	48	252	51.5	60	56	264	264/264			
		282/273A00	25.0	30.1	-	49.8	50	46	250	57.5	60	53	262	52.5	60	48	252	60.3	70	56	264				
		283/274A00	50.0	60.1	-	72.2	80	80	250	80.0	90	87	262	75.0	80	83	252	82.7	90	90	264				
		284/275A00	75.0	90.2	-	102.3	125	115	250	110.1	125	122	262	105.1	125	117	252	112.8	125	125	264				
HIGH		NONE	-	-	-	47.3	60	50	287	53.5	60	58	299	49.5	60	53	289	55.7	60	60	301	301/301			
		282/273A00	25.0	30.1	-	54.8	60	50	287	62.5	70	58	299	57.5	60	53	289	65.3	70	60	301				
		283/274A00	50.0	60.1	-	77.2	90	85	287	85.0	90	92	299	80.0	90	87	289	87.7	90	95	301				
		284/275A00	75.0	90.2	-	107.3	125	119	287	115.1	125	127	299	110.1	125	122	289	117.8	125	129	301				
ULTRA		NONE	-	-	-	51.3	60	54	307	57.5	70	61	319	53.5	60	57	309	59.7	70	64	321	321/321			
		282/273A00	25.0	30.1	-	58.8	60	54	307	66.5	70	61	319	61.5	70	57	309	69.3	70	64	321				
		283/274A00	50.0	60.1	-	81.2	90	89	307	89.0	100	96	319	84.0	100	91	309	91.7	100	98	321				
		284/275A00	75.0	90.2	-	111.3	125	123	307	119.1	125	130	319	114.1	125	126	309	121.8	125	133	321				

See "Legend and Notes for Tables 21 and 22" on page 92.

**Table 21 - Unit Wire/Fuse or HACR Breaker Sizing Data (cont)**

UNIT	NO. M. V.-Ph-HZ	IFM TYPE	ELEC. HTR		NO. C.O. or UNPWR C.O.																								
			CRHEATER**A00 VERT/HORZ	Nom (KW)	FLA	NO P.E.				w/P.E. (pwrd fr/unit)				NO P.E.				w/P.E. (pwrd fr/unit)											
						MCA	MAX FUSE or HACR BRKR	FLA	LRA	DISC. SIZE	MCA	MAX FUSE or HACR BRKR	FLA	LRA	DISC. SIZE	MCA	MAX FUSE or HACR BRKR	FLA	LRA	DISC. SIZE	MCA	MAX FUSE or HACR BRKR	FLA	LRA	DISC. SIZE				
50LC-020	575-3-60	STD	NONE	-	-	31.8	40	34	182	190	39	190	45	45	39	190	33.5	40	36	184	38.3	40	36	184	45	45	41	192	
			285/276A00	24.8	23.9	35.5	40	34	182	190	39	190	45	45	39	190	37.6	40	36	184	43.6	40	36	184	45	45	41	192	
			286/277A00	49.6	47.7	65.3	70	60	182	190	66	190	80	80	66	190	67.4	70	62	184	73.4	70	62	184	80	80	68	192	
			287/278A00	74.4	71.6	77.2	90	88	182	190	93	190	90	90	93	190	79.4	90	89	184	85.4	90	89	184	90	90	95	192	
50LC-020	575-3-60	MED	NONE	-	-	34.5	40	37	194	202	42	202	45	45	42	202	36.2	45	39	196	41.0	45	39	196	50	50	44	204	
			285/276A00	24.8	23.9	38.9	40	37	194	194	42	194	44.9	45	42	194	41.0	45	39	196	47.0	45	39	196	50	50	44	204	
			286/277A00	49.6	47.7	68.6	70	63	194	194	69	194	74.6	80	80	69	202	70.8	80	65	196	76.8	80	65	196	80	80	71	204
			287/278A00	74.4	71.6	80.6	90	91	194	194	96	202	86.6	90	90	96	202	82.7	90	93	196	88.7	90	93	196	90	90	98	204
50LC-020	575-3-60	HIGH	NONE	-	-	36.2	45	39	221	229	44	229	50	50	44	229	37.9	45	41	223	42.7	45	41	223	50	50	46	231	
			285/276A00	24.8	23.9	41.0	45	39	221	221	44	229	47.0	50	50	44	229	43.1	45	41	223	49.1	45	41	223	50	50	46	231
			286/277A00	49.6	47.7	70.8	80	65	221	221	71	229	76.8	80	80	71	229	72.9	80	67	223	78.9	80	67	223	80	80	73	231
			287/278A00	74.4	71.6	82.7	90	93	221	221	98	229	88.7	90	90	98	229	84.9	90	95	223	90.9	90	95	223	100	100	100	231
50LC-020	575-3-60	ULTRA	NONE	-	-	40.5	50	43	232	240	48	240	50	50	48	240	42.2	50	45	234	47.0	50	45	234	60	60	50	242	
			285/276A00	24.8	23.9	45.6	50	43	232	232	48	240	51.6	60	60	48	240	47.8	50	45	234	53.8	50	45	234	60	60	50	242
			286/277A00	49.6	47.7	75.4	80	69	232	232	75	240	81.4	90	90	75	240	77.5	80	71	234	83.5	90	71	234	90	90	77	242
			287/278A00	74.4	71.6	87.4	100	97	232	232	102	240	93.4	100	100	102	240	89.5	100	99	234	95.5	100	99	234	100	100	104	242

See "Legend and Notes for Tables 21 and 22" on page 92.

**Table 21 - Unit Wire/Fuse or HACR Breaker Sizing Data (cont)**

UNIT	NO M. V - Ph - HZ	ELEC. HTR				NO C.O. or UNPWR C.O.										w/ PWRD C.O.														
		CRHEATER/A00 VERT/HORZ	Nom (kW)	FLA	MCA	NO P.E.			w/ P.E. (pwrd ft/unit)			NO P.E.			w/ P.E. (pwrd ft/unit)			NO P.E.			w/ P.E. (pwrd ft/unit)									
						MAX FUSE or HACR BRKR	FLA	DISC. SIZE	FLA	LRA	DISC. SIZE	MCA	MAX FUSE or HACR BRKR	FLA	DISC. SIZE	FLA	LRA	DISC. SIZE	MCA	MAX FUSE or HACR BRKR	FLA	DISC. SIZE	FLA	LRA	DISC. SIZE	MCA	MAX FUSE or HACR BRKR	FLA	DISC. SIZE	FLA
STD		NONE	-	-	-	101.9	125	108	538	121	588	106.7	125	113	543	118.5	150	127	563	127	563	127	563	150	127	563	127	563	127	563
		279/270A00	18.8/25.0	52.1/60.1	101.9/101.9	125/125	108/108	538/538	121/121	588/588	106.7/107.6	125/125	113/113	543/543	118.5/122.4	150/150	127/127	563/563	127/127	563/563	127/127	563/563	150/150	127/127	563/563	127/127	563/563	127/127	563/563	
		280/271A00	37.6/50.0	104.2/120.3	156.8/146.8	175/175	144/163	538/538	158/176	588/588	162.8/152.8	175/175	150/168	543/543	177.5/167.6	200/175	163/182	563/563	163/182	563/563	163/182	563/563	200/175	163/182	563/563	163/182	563/563	163/182	563/563	
		281/272A00	56.3/75.0	156.4/180.4	182.9/206.9	200/250	204/232	538/538	218/245	588/588	188.9/212.9	225/250	210/237	543/543	203.7/227.7	225/250	223/251	563/563	223/251	563/563	223/251	563/563	200/250	210/237	543/543	203.7/227.7	225/250	223/251	563/563	
MED		NONE	-	-	-	101.9	125	108	538	121	588	106.7	125	113	543	118.5	150	127	563	127	563	127	563	150	127	563	127	563	127	563
		279/270A00	18.8/25.0	52.1/60.1	101.9/101.9	125/125	108/108	538/538	121/121	588/588	106.7/107.6	125/125	113/113	543/543	118.5/122.4	150/150	127/127	563/563	127/127	563/563	127/127	563/563	150/150	127/127	563/563	127/127	563/563	127/127	563/563	
		280/271A00	37.6/50.0	104.2/120.3	156.8/146.8	175/175	144/163	538/538	158/176	588/588	162.8/152.8	175/175	150/168	543/543	177.5/167.6	200/175	163/182	563/563	163/182	563/563	163/182	563/563	200/175	163/182	563/563	163/182	563/563	163/182	563/563	
		281/272A00	56.3/75.0	156.4/180.4	182.9/206.9	200/250	204/232	538/538	218/245	588/588	188.9/212.9	225/250	210/237	543/543	203.7/227.7	225/250	223/251	563/563	223/251	563/563	223/251	563/563	200/250	210/237	543/543	203.7/227.7	225/250	223/251	563/563	
HIGH		NONE	-	-	-	108.7	125	115	612	129	632	113.5	125	121	617	125.3	150	135	637	135	637	135	637	150	135	637	135	637	135	637
		279/270A00	18.8/25.0	52.1/60.1	108.7/110.1	125/125	115/115	612/612	129/129	632/632	113.5/116.1	125/125	121/121	617/617	125.3/130.9	150/150	135/135	637/637	135/135	637/637	135/135	637/637	150/150	135/135	637/637	135/135	637/637	135/135	637/637	
		280/271A00	37.6/50.0	104.2/120.3	165.3/155.3	175/175	152/171	612/612	166/184	632/632	171.3/161.3	200/175	158/176	617/617	186.0/176.1	200/200	171/190	637/637	171/190	637/637	171/190	637/637	200/200	171/190	637/637	171/190	637/637	171/190	637/637	
		281/272A00	56.3/75.0	156.4/180.4	191.4/215.4	200/250	212/240	612/612	226/253	632/632	197.4/221.4	225/250	218/245	617/617	212.2/236.2	225/250	231/259	637/637	231/259	637/637	231/259	637/637	200/250	218/245	617/617	212.2/236.2	225/250	231/259	637/637	
ULTRA		NONE	-	-	-	119.0	150	126	652	140	672	123.8	150	132	657	135.6	150	145	677	145	677	145	677	150	145	677	145	677	145	677
		279/270A00	18.8/25.0	52.1/60.1	119.0/121.8	150/150	126/126	652/652	140/140	672/672	123.8/127.8	150/150	132/132	657/657	135.6/142.5	150/150	145/145	677/677	145/145	677/677	145/145	677/677	150/150	145/145	677/677	145/145	677/677	145/145	677/677	
		280/271A00	37.6/50.0	104.2/120.3	176.9/166.9	200/200	163/181	652/652	176/195	672/672	182.9/172.9	200/200	168/187	657/657	197.6/187.7	200/200	182/200	677/677	182/200	677/677	182/200	677/677	200/200	168/187	657/657	197.6/187.7	200/200	182/200	677/677	
		281/272A00	56.3/75.0	156.4/180.4	203.0/227.0	225/250	223/250	652/652	236/264	672/672	209.0/233.0	225/250	228/256	657/657	223.8/247.8	250/300	242/269	677/677	242/269	677/677	242/269	677/677	200/200	218/245	617/617	212.2/236.2	225/250	231/259	637/637	
STD		NONE	-	-	-	56.6	70	60	278	67	290	58.8	70	62	280	65.0	80	70	292	70	292	70	292	80	70	292	70	292	70	292
		282/273A00	25.0	30.1	56.6	70	60	278	67	290	58.8	70	62	280	65.0	80	70	292	70	292	70	292	80	70	292	70	292	70	292	
		283/274A00	50.0	60.1	72.2	80	80	278	87	290	75.0	80	83	280	82.7	90	90	292	90	292	90	292	90	90	292	90	292	90	292	
		284/275A00	75.0	90.2	102.3	125	115	278	122	290	105.1	125	117	280	112.8	125	125	292	125	292	125	292	125	125	292	125	292	125	292	
MED		NONE	-	-	-	56.6	70	60	278	67	290	58.8	70	62	280	65.0	80	70	292	70	292	70	292	80	70	292	70	292	70	292
		282/273A00	25.0	30.1	56.6	70	60	278	67	290	58.8	70	62	280	65.0	80	70	292	70	292	70	292	80	70	292	70	292	70	292	
		283/274A00	50.0	60.1	72.2	80	80	278	87	290	75.0	80	83	280	82.7	90	90	292	90	292	90	292	90	90	292	90	292	90	292	
		284/275A00	75.0	90.2	102.3	125	115	278	122	290	105.1	125	117	280	112.8	125	125	292	125	292	125	292	125	125	292	125	292	125	292	
HIGH		NONE	-	-	-	60.6	70	65	315	72	327	62.8	80	67	317	69.0	80	74	329	74	329	74	329	80	74	329	74	329	74	329
		282/273A00	25.0	30.1	60.6	70	65	315	72	327	62.8	80	67	317	69.0	80	74	329	74	329	74	329	80	74	329	74	329	74	329	
		283/274A00	50.0	60.1	77.2	80	85	315	92	327	80.0	90	87	317	87.7	90	95	329	95	329	95	329	90	95	329	90	329	90	329	
		284/275A00	75.0	90.2	107.3	125	119	315	127	327	110.1	125	122	317	117.8	125	129	329	129	329	129	329	125	125	329	125	329	125	329	
ULTRA		NONE	-	-	-	63.8	80	68	335	75	347	66.0	80	71	337	72.2	90	78	349	78	349	78	349	90	78	349	78	349	78	349
		282/273A00	25.0	30.1	63.8	80	68	335	75	347	66.0	80	71	337	72.2	90	78	349	78	349	78	349	90	78	349	78	349	78	349	
		283/274A00	50.0	60.1	81.2	90	89	335	96	347	84.0	100	91	337	91.7	100	98	349	98	349	98	349	100	98	349	98	349	98	349	
		284/275A00	75.0	90.2	111.3	125	123	335	130	347	114.1	125	126	337	121.8	125	133	349	133	349	133	349	125	125	349	125	349	125	349	

See "Legend and Notes for Tables 21 and 22" on page 92.

**Table 21 - Unit Wire/Fuse or HACR Breaker Sizing Data (cont)**

UNIT	NO. M. V.-Ph-HZ	ELEC. HTR				NO. C.O. or UNIPWR C.O.																										
		CRHEATER™A00 VERT/HORZ	Nom (kW)	FLA	NO P.E.				w/ P.E. (pwrd fr/unit)				NO P.E.				w/ PWRD C.O.															
					MCA	MAX FUSE or HACR BRKR	FLA	LRA	DISC. SIZE	MCA	MAX FUSE or HACR BRKR	FLA	LRA	DISC. SIZE	MCA	MAX FUSE or HACR BRKR	FLA	LRA	DISC. SIZE	MCA	MAX FUSE or HACR BRKR	FLA	LRA	DISC. SIZE								
STD		NONE	-	-	48	206	49.8	60	54	214	46.7	50	208	51.5	60	56	216	46.7	50	208	51.5	60	56	216	46.7	50	208	51.5	60	56	216	
		285/276A00	24.8	23.9	48	206	49.8	60	54	214	46.7	50	208	51.5	60	56	216	46.7	50	208	51.5	60	56	216	46.7	50	208	51.5	60	56	216	
		286/277A00	49.6	47.7	63	206	74.6	80	69	214	70.8	80	208	76.8	80	65	208	76.8	80	208	76.8	80	71	216	76.8	80	71	216	76.8	80	71	216
		287/278A00	74.4	71.6	91	206	86.6	90	96	214	82.7	90	208	88.7	90	93	208	88.7	90	208	88.7	90	98	216	88.7	90	98	216	88.7	90	98	216
MED		NONE	-	-	48	206	49.8	60	54	214	46.7	50	208	51.5	60	56	216	46.7	50	208	51.5	60	56	216	46.7	50	208	51.5	60	56	216	
		285/276A00	24.8	23.9	48	206	49.8	60	54	214	46.7	50	208	51.5	60	56	216	46.7	50	208	51.5	60	56	216	46.7	50	208	51.5	60	56	216	
		286/277A00	49.6	47.7	63	206	74.6	80	69	214	70.8	80	208	76.8	80	65	208	76.8	80	208	76.8	80	71	216	76.8	80	71	216	76.8	80	71	216
		287/278A00	74.4	71.6	91	206	86.6	90	96	214	82.7	90	208	88.7	90	93	208	88.7	90	208	88.7	90	98	216	88.7	90	98	216	88.7	90	98	216
HIGH		NONE	-	-	50	233	51.5	60	56	241	48.4	60	235	53.2	60	58	243	48.4	60	235	53.2	60	58	243	48.4	60	235	53.2	60	58	243	
		285/276A00	24.8	23.9	50	233	51.5	60	56	241	48.4	60	235	53.2	60	58	243	48.4	60	235	53.2	60	58	243	48.4	60	235	53.2	60	58	243	
		286/277A00	49.6	47.7	65	233	76.8	80	71	241	72.9	80	235	78.9	80	67	235	78.9	80	235	78.9	80	73	243	78.9	80	73	243	78.9	80	73	243
		287/278A00	74.4	71.6	93	233	88.7	90	98	241	84.9	90	235	90.9	90	95	235	90.9	90	235	90.9	90	100	243	90.9	90	100	243	90.9	90	100	243
ULTRA		NONE	-	-	54	244	55.2	60	60	252	52.1	60	246	56.9	70	62	254	52.1	60	246	56.9	70	62	254	52.1	60	246	56.9	70	62	254	
		285/276A00	24.8	23.9	54	244	55.2	60	60	252	52.1	60	246	56.9	70	62	254	52.1	60	246	56.9	70	62	254	52.1	60	246	56.9	70	62	254	
		286/277A00	49.6	47.7	69	244	81.4	90	75	252	77.5	80	246	83.5	90	71	246	83.5	90	246	83.5	90	77	254	83.5	90	77	254	83.5	90	77	254
		287/278A00	74.4	71.6	97	244	93.4	100	102	252	89.5	100	246	95.5	100	99	246	95.5	100	246	95.5	100	104	254	95.5	100	104	254	95.5	100	104	254

See "Legend and Notes for Tables 21 and 22" on page 92.



**Table 21 - Unit Wire/Fuse or HACR Breaker Sizing Data (cont)**

UNIT	NO M. V.-Ph-HZ	IFM TYPE	ELEC. HTR			NO C.O. or UNPWR C.O.						w/ PWRD C.O.							
			CRHEATER-A00 VERT/HORZ	Nom (kW)	FLA	NO P.E.			w/ P.E. (pwrld ft/unit)			NO P.E.			w/ P.E. (pwrld ft/unit)				
						MAX FUSE or HACR BRKR	FLA	LRA	DISC. SIZE	MCA	MAX FUSE or HACR BRKR	FLA	LRA	DISC. SIZE	MCA	MAX FUSE or HACR BRKR	FLA	LRA	DISC. SIZE
STD			NONE	-	-	129	629	136.7	175	142	649	129.7	175	134	634	141.5	175	148	654
			279/270A00	18.8/25.0	52.1/60.1	129/129	629/629	136.7/136.7	175/175	142/142	649/649	129.7/129.7	175/175	134/134	634/634	141.5/141.5	175/175	148/148	654/654
			280/271A00	37.6/50.0	104.2/120.3	144/163	629/629	171.5/161.6	175/175	158/176	649/649	162.8/152.8	175/175	150/168	634/634	177.5/167.6	200/175	163/182	654/654
			281/272A00	56.3/75.0	156.4/180.4	204/232	629/629	197.7/221.7	225/250	218/245	649/649	188.9/212.9	200/250	210/237	634/634	203.7/227.7	225/250	223/251	654/654
MED	208/230-3-60		NONE	-	-	137	703	143.5	175	150	723	136.5	175	142	708	148.3	175	156	728
			279/270A00	18.8/25.0	52.1/60.1	137/137	703/703	143.5/143.5	175/175	150/150	723/723	136.5/136.5	175/175	142/142	708/708	148.3/148.3	175/175	156/156	728/728
			280/271A00	37.6/50.0	104.2/120.3	152/171	703/703	180.0/170.1	200/175	166/184	723/723	171.3/161.3	175/175	158/176	708/708	186.0/176.1	200/200	171/190	728/728
			281/272A00	56.3/75.0	156.4/180.4	212/240	703/703	206.2/230.2	225/250	226/253	723/723	197.4/221.4	225/250	218/245	708/708	212.2/236.2	225/250	231/259	728/728
HIGH	50LC-026		NONE	-	-	147	743	152.8	200	161	763	145.8	175	153	748	157.6	200	167	768
			279/270A00	18.8/25.0	52.1/60.1	147/147	743/743	152.8/152.8	200/200	161/161	763/763	145.8/145.8	175/175	153/153	748/748	157.6/157.6	200/200	167/167	768/768
			280/271A00	37.6/50.0	104.2/120.3	163/181	743/743	191.6/181.7	200/200	176/195	763/763	182.9/172.9	200/200	168/187	748/748	197.6/187.7	200/200	182/200	768/768
			281/272A00	56.3/75.0	156.4/180.4	223/250	743/743	217.8/241.8	250/250	236/264	763/763	209.0/233.0	225/250	228/256	748/748	223.8/247.8	250/300	242/269	768/768
STD			NONE	-	-	68	322	71.1	90	75	334	67.1	90	70	324	73.3	90	78	336
			282/273A00	25.0	30.1	68	322	71.1	90	75	334	67.1	90	70	324	73.3	90	78	336
			283/274A00	50.0	60.1	80	322	80.0	90	87	334	75.0	90	83	324	82.7	90	90	336
			284/275A00	75.0	90.2	115	322	110.1	125	122	334	105.1	125	117	324	112.8	125	125	336
MED	460-3-60		NONE	-	-	73	359	75.1	90	80	371	71.1	90	75	361	77.3	100	82	373
			282/273A00	25.0	30.1	73	359	75.1	90	80	371	71.1	90	75	361	77.3	100	82	373
			283/274A00	50.0	60.1	85	359	85.0	90	92	371	80.0	90	87	361	87.7	100	95	373
			284/275A00	75.0	90.2	119	359	115.1	125	127	371	110.1	125	122	361	117.8	125	129	373
HIGH			NONE	-	-	76	379	78.3	100	83	391	74.3	90	79	381	80.5	100	86	393
			282/273A00	25.0	30.1	76	379	78.3	100	83	391	74.3	90	79	381	80.5	100	86	393
			283/274A00	50.0	60.1	89	379	89.0	100	96	391	84.0	100	91	381	91.7	100	98	393
			284/275A00	75.0	90.2	123	379	119.1	125	130	391	114.1	125	126	381	121.8	125	133	393

See "Legend and Notes for Tables 21 and 22" on page 92.

**Table 21 - Unit Wire/Fuse or HACR Breaker Sizing Data (cont)**

UNIT	NO. M. V-PH-HZ	IFM TYPE	ELEC. HTR		NO. C.O. or UNPWR C.O.																								
			CRHEATER™ A00 VERT/HORZ	Nom (kW)	FLA	NO P.E.				w/P.E. (pwrd fr/unit)				NO P.E.				w/PWR C.O.											
						MCA	MAX FUSE or HACR BRKR	FLA	LRA	DISC. SIZE	MCA	MAX FUSE or HACR BRKR	FLA	LRA	DISC. SIZE	MCA	MAX FUSE or HACR BRKR	FLA	LRA	DISC. SIZE	MCA	MAX FUSE or HACR BRKR	FLA	LRA	DISC. SIZE				
50LC-026	575-3-60	STD	NONE	-	-	53.9	60	56	235	235	243	58.7	70	62	243	55.6	70	58	237	237	60.4	80	58	237	60.4	80	64	245	245
			285/276A00	24.8	23.9	53.9	60	56	235	235	243	58.7	70	62	243	55.6	70	58	237	237	60.4	80	58	237	60.4	80	64	245	245
			286/277A00	49.6	47.7	68.6	70	63	235	235	243	74.6	80	69	243	70.8	80	65	237	237	76.8	80	65	237	76.8	80	71	245	245
			287/278A00	74.4	71.6	80.6	90	91	235	235	243	86.6	90	96	243	82.7	90	93	237	237	88.7	90	93	237	88.7	90	98	245	245
575-3-60	575-3-60	MED	NONE	-	-	55.6	70	58	262	262	270	60.4	80	64	270	57.3	70	60	264	264	62.1	80	60	264	62.1	80	66	272	272
			285/276A00	24.8	23.9	55.6	70	58	262	262	270	60.4	80	64	270	57.3	70	60	264	264	62.1	80	60	264	62.1	80	66	272	272
			286/277A00	49.6	47.7	70.8	80	65	262	262	270	76.8	80	71	270	72.9	80	67	264	264	78.9	80	67	264	78.9	80	73	272	272
			287/278A00	74.4	71.6	82.7	90	93	262	262	270	88.7	90	98	270	84.9	90	95	264	264	90.9	100	95	264	90.9	100	100	272	272
575-3-60	575-3-60	HIGH	NONE	-	-	59.3	70	62	273	273	281	64.1	80	68	281	61.0	80	64	275	275	65.8	80	64	275	65.8	80	70	283	283
			285/276A00	24.8	23.9	59.3	70	62	273	273	281	64.1	80	68	281	61.0	80	64	275	275	65.8	80	64	275	65.8	80	70	283	283
			286/277A00	49.6	47.7	75.4	80	69	273	273	281	81.4	90	75	281	77.5	80	71	275	275	83.5	90	71	275	83.5	90	77	283	283
			287/278A00	74.4	71.6	87.4	100	97	273	273	281	93.4	100	102	281	89.5	100	99	275	275	95.5	100	99	275	95.5	100	104	283	283

See "Legend and Notes for Tables 21 and 22" on page 92.

**Table 22 – Unit Wire Sizing Data with Factory-Installed HACR Breaker**

UNIT	NO M. V.-Ph-HZ	ELEC. HTR				NO C.O. or UNPWR C.O.								w/ PWRD C.O.										
		CRHEATER™A00 VERT/HORZ	Nom (kW)	FLA	MCA	NO P.E.				w/ P.E. (pwrd ft/unit)				NO P.E.				w/ P.E. (pwrd ft/unit)						
						HACR BRKR	FLA	LRA	DISC. SIZE	MCA	HACR BRKR	FLA	LRA	DISC. SIZE	MCA	HACR BRKR	FLA	LRA	DISC. SIZE	MCA	HACR BRKR	FLA	LRA	DISC. SIZE
STD		NONE	-	-	59.1/59.1	80/80	61/60	343	343	70.9/70.9	90/90	75/74	363	363	63.9/63.9	80/80	67/66	348	348	75.7/75.7	90/90	80/79	368	368
		302/306A00	11.3/15.0	31.3/36.1	59.1/59.1	80/80	61/60	343/343	343/343	70.9/70.9	90/90	75/74	363/363	363/363	63.9/63.9	80/80	67/66	348/348	348/348	75.7/75.7	90/90	80/79	368/368	368/368
		279/270A00	18.8/25.0	52.1/60.1	84.9/84.9	90/90	70/78	343/343	343/343	99.6/99.6	100/100	83/92	363/363	363/363	90.9/90.9	100/100	75/84	348/348	348/348	105.6/105.6	110/110	89/97	368/368	368/368
		309/312A00	37.6/50.0	104.2/120.3	141.0/141.0	150/150	130/147	343/343	343/343	155.8/155.8	175/175	143/161	363/363	363/363	147.0/147.0	150/150	135/153	348/348	348/348	161.8/161.8	175/175	149/166	368/368	368/368
MED	208/230-3-60	NONE	-	-	64.1/64.1	80/80	67/66	378	378	75.9/75.9	90/90	81/80	398	398	68.9/68.9	90/90	73/72	383	383	80.7/80.7	100/100	86/85	403	403
		302/306A00	11.3/15.0	31.3/36.1	64.1/64.1	80/80	67/66	378/378	378/378	75.9/75.9	90/90	81/80	398/398	398/398	68.9/68.9	90/90	73/72	383/383	383/383	81.8/81.8	100/100	86/85	403/403	403/403
		279/270A00	18.8/25.0	52.1/60.1	91.0/91.0	100/100	76/84	378/378	378/378	105.8/105.8	110/110	89/97	398/398	398/398	97.0/97.0	100/100	81/89	383/383	383/383	111.8/111.8	125/125	95/103	403/403	403/403
		309/312A00	37.6/50.0	104.2/120.3	147.3/147.3	150/150	135/153	378/378	378/378	162.0/162.0	175/175	149/167	398/398	398/398	153.3/153.3	175/175	141/158	383/383	383/383	168.0/168.0	200/200	155/172	403/403	403/403
HIGH		NONE	-	-	71.7	90	76	382	382	83.5	100	89	402	402	76.5	90	81	387	387	88.3	100	95	407	407
		302/306A00	11.3/15.0	31.3/36.1	71.7/71.7	90/90	76/76	382/382	382/382	86.4/86.4	100/100	89/89	402/402	402/402	77.6/77.6	90/90	81/81	387/387	387/387	92.4/92.4	100/100	95/95	407/407	407/407
		279/270A00	18.8/25.0	52.1/60.1	101.6/101.6	110/110	84/93	382/382	382/382	116.4/116.4	125/125	98/107	402/402	402/402	107.6/107.6	110/110	90/99	387/387	387/387	122.4/122.4	125/125	103/113	407/407	407/407
		309/312A00	37.6/50.0	104.2/120.3	156.8/156.8	175/175	144/163	382/382	382/382	171.5/171.5	200/200	158/176	402/402	402/402	162.8/162.8	175/175	150/168	387/387	387/387	177.5/177.5	200/200	163/182	407/407	407/407
ULTRA	50LC-014	NONE	-	-	79.7	100	84	456	456	91.5	100	97	476	476	84.5	100	89	461	461	96.3	110	103	481	481
		302/306A00	11.3/15.0	31.3/36.1	80.1/80.1	100/100	84/84	456/456	456/456	94.9/94.9	100/100	97/97	476/476	476/476	86.1/86.1	100/100	89/89	461/461	461/461	100.9/100.9	110/110	103/103	481/481	481/481
		279/270A00	18.8/25.0	52.1/60.1	110.1/110.1	125/125	92/101	456/456	456/456	124.9/124.9	125/125	106/115	476/476	476/476	116.1/116.1	125/125	98/107	461/461	461/461	130.9/130.9	150/150	111/120	481/481	481/481
		309/312A00	37.6/50.0	104.2/120.3	165.3/165.3	175/175	152/171	456/456	456/456	180.0/180.0	200/200	166/184	476/476	476/476	171.3/171.3	175/175	158/176	461/461	461/461	186.0/186.0	200/200	171/190	481/481	481/481
STD		NONE	-	-	31.3	40	33	167	167	37.5	45	40	179	179	33.5	40	35	169	169	39.7	50	42	181	181
		303/306A00	15.0	18.0	31.3	40	33	167	167	37.5	45	40	179	179	33.5	40	35	169	169	39.7	50	42	181	181
		282/273A00	25.0	30.1	42.4	45	39	167	167	50.1	60	46	179	179	45.1	50	42	169	169	52.9	60	49	181	181
		310/313A00	50.0	60.1	64.9	70	73	167	167	72.6	80	81	179	179	67.6	80	76	169	169	75.4	80	83	181	181
MED	460-3-60	NONE	-	-	33.9	45	36	184	184	40.1	50	43	196	196	36.1	45	38	186	186	42.3	50	45	198	198
		303/306A00	15.0	18.0	33.9	45	36	184	184	40.1	50	43	196	196	36.1	45	38	186	186	42.3	50	45	198	198
		282/273A00	25.0	30.1	45.6	50	42	184	184	53.4	60	49	196	196	48.4	50	45	186	186	56.1	60	52	198	198
		310/313A00	50.0	60.1	68.1	80	76	184	184	75.9	80	84	196	196	70.9	80	79	186	186	78.6	80	86	198	198
HIGH		NONE	-	-	37.2	45	40	186	186	43.4	50	47	198	198	39.4	50	42	188	188	45.6	50	49	200	200
		303/306A00	15.0	18.0	37.2	45	40	186	186	43.4	50	47	198	198	39.4	50	42	188	188	45.6	50	49	200	200
		282/273A00	25.0	30.1	49.8	50	46	186	186	57.5	60	53	198	198	52.5	60	48	188	188	60.3	70	55	200	200
		310/313A00	50.0	60.1	72.2	80	80	186	186	80.0	90	87	198	198	75.0	80	83	188	188	82.7	90	90	200	200
ULTRA		NONE	-	-	41.8	50	44	223	223	48.0	60	51	235	235	44.0	50	47	225	225	50.2	60	54	237	237
		303/306A00	15.0	18.0	41.8	50	44	223	223	48.0	60	51	235	235	44.0	50	47	225	225	50.2	60	54	237	237
		282/273A00	25.0	30.1	54.8	60	50	223	223	62.5	70	58	235	235	57.5	60	53	225	225	65.3	70	60	237	237
		310/313A00	50.0	60.1	77.2	90	85	223	223	85.0	90	92	235	235	80.0	90	87	225	225	87.7	90	95	237	237

See "Legend and Notes for Tables 21 and 22" on page 92.

**Table 22 - Unit Wire Sizing Data with Factory-Installed HACR Breaker (cont)**

UNIT	NO M.V.-Ph-HZ	ELEC. HTR			NO C.O. or UNPWR C.O.															
		CRHEATER™A00 VERT/HORZ	Nom (kW)	FLA	NO P.E.				w/ P.E. (pwrd ft/unit)				NO P.E.				w/ P.E. (pwrd ft/unit)			
					MCA	HACR BRKR	FLA	LRA	DISC. SIZE	MCA	HACR BRKR	FLA	LRA	DISC. SIZE	MCA	HACR BRKR	FLA	LRA	DISC. SIZE	
STD		NONE	-	-	26.4	30	26	119	29.2	35	31	127	26.1	30	28	121	30.9	35	33	129
		304/307A00	15.0	14.4	24.4	30	26	119	29.6	35	31	127	26.1	30	28	121	31.8	35	33	129
		285/276A00	24.8	23.9	35.5	40	33	119	41.5	45	38	127	37.6	40	35	121	43.6	45	40	129
		311/314A00	49.6	47.7	65.3	70	60	119	71.3	80	66	127	67.4	70	62	121	73.4	80	68	129
MED		NONE	-	-	26.1	30	28	133	30.9	35	33	141	27.8	30	30	135	32.6	40	35	143
		304/307A00	15.0	14.4	26.1	30	28	133	31.8	35	33	141	27.9	30	30	135	33.9	40	35	143
		285/276A00	24.8	23.9	37.6	40	35	133	43.6	45	40	141	39.8	40	37	135	45.8	50	42	143
		311/314A00	49.6	47.7	67.4	70	62	133	73.4	80	68	141	69.5	70	64	135	75.5	80	69	143
HIGH		NONE	-	-	27.1	30	29	131	31.9	35	34	139	28.8	35	31	133	33.6	40	36	141
		304/307A00	15.0	14.4	27.1	30	29	131	33.0	35	34	139	29.1	35	31	133	35.1	40	36	141
		285/276A00	24.8	23.9	38.9	40	36	131	44.9	45	41	139	41.0	45	38	133	47.0	50	43	141
		311/314A00	49.6	47.7	68.6	70	63	131	74.6	80	69	139	70.8	80	65	133	76.8	80	71	141
ULTRA		NONE	-	-	29.0	35	31	158	33.8	40	36	166	30.7	35	33	160	35.5	40	38	168
		304/307A00	15.0	14.4	29.1	35	31	158	35.1	40	36	166	31.3	35	33	160	37.3	40	38	168
		285/276A00	24.8	23.9	41.0	45	38	158	47.0	50	43	166	43.1	45	40	160	49.1	50	45	168
		311/314A00	49.6	47.7	70.8	80	65	158	76.8	80	71	166	72.9	80	67	160	78.9	80	73	168

See "Legend and Notes for Tables 21 and 22" on page 92.

**Table 22 - Unit Wire Sizing Data with Factory-Installed HACR Breaker (cont)**

UNIT	NO M. V.-Ph-HZ	ELEC. HTR				NO C.O. or UNPWR C.O.												w/ PWRD C.O.											
		IFM TYPE	CRHEATER/A00 VERT/HORZ	Nom (kW)	FLA	NO P.E.				w/ P.E. (pwrd ft/unit)				NO P.E.				w/ P.E. (pwrd ft/unit)											
						MCA	HACR BRKR	FLA	LRA	DISC. SIZE	MCA	HACR BRKR	FLA	LRA	DISC. SIZE	MCA	HACR BRKR	FLA	LRA	DISC. SIZE									
STD		NONE	-	-	-	67.4/67.4	90/90	70/69	371	79.2/79.2	100/100	83/82	391	376	75/74	90/90	75/74	90	415	96.6	110	103	89/88	396					
		279/270A00	18.8/25.0	52.1/60.1	84.9/84.9	70/78	371/371	99.6/99.6	100/100	83/92	391/391	100/100	83/92	391/391	376/376	100/100	75/84	90	415	105.6/105.6	110/110	103/113	89/97	396/396					
		280/271A00	37.6/50.0	104.2/120.3	141.0/141.0	130/147	371/371	155.8/155.8	175/175	143/161	391/391	150/150	135/153	376/376	161.8/161.8	175/175	135/153	150	415	210.9/210.9	225/225	209/236	149/166	396/396					
		281/272A00	56.3/75.0	156.4/180.4	190.2/190.2	190/216	371/371	204.9/204.9	225/225	203/230	391/391	200/200	195/222	376/376	210.9/210.9	225/225	195/222	200	415	227.7/227.7	250/250	223/251	209/236	396/396					
MED		NONE	-	-	84	410	91.8	100	430	84.8	100	98	430	415	90	100	90	415	96.6	110	103	103	435						
		279/270A00	18.8/25.0	52.1/60.1	101.6/101.6	84/93	410/410	116.4/116.4	125/125	98/107	430/430	110/110	90/99	415/415	122.4/122.4	110/110	90/99	415/415	122.4/122.4	125/125	103/113	435/435							
		280/271A00	37.6/50.0	104.2/120.3	156.8/156.8	144/163	410/410	171.5/171.5	175/175	158/176	430/430	175/175	150/168	415/415	177.5/177.5	200/200	150/168	415/415	177.5/177.5	200/200	163/182	435/435							
		281/272A00	56.3/75.0	156.4/180.4	206.9/206.9	204/232	410/410	221.7/221.7	225/250	218/245	430/430	225/250	210/237	415/415	227.7/227.7	250/250	210/237	415/415	227.7/227.7	250/250	223/251	435/435							
HIGH		NONE	-	-	92	484	98.7	125	504	91.7	100	105	504	489	97	100	97	489	103.5	125	111	509							
		279/270A00	18.8/25.0	52.1/60.1	110.1/110.1	92/101	484/484	124.9/124.9	125/125	106/115	504/504	125/125	106/115	504/504	489/489	98/107	125/125	489/489	130.9/130.9	150/150	111/120	509/509							
		280/271A00	37.6/50.0	104.2/120.3	165.3/165.3	152/171	484/484	180.0/180.0	200/200	166/184	504/504	175/175	158/176	489/489	186.0/186.0	200/200	158/176	489/489	186.0/186.0	200/200	171/190	509/509							
		281/272A00	56.3/75.0	156.4/180.4	215.4/215.4	212/240	484/484	230.2/230.2	250/250	226/253	504/504	225/250	218/245	489/489	236.2/236.2	250/250	218/245	489/489	236.2/236.2	250/250	231/259	509/509							
ULTRA		NONE	-	-	103	524	110.3	125	544	103.3	125	116	544	529	108	125	108	529	115.1	150	122	549							
		279/270A00	18.8/25.0	52.1/60.1	121.8/121.8	103/112	524/524	136.5/136.5	150/150	116/126	544/544	150/150	108/118	529/529	142.5/142.5	150/150	108/118	529/529	142.5/142.5	150/150	122/131	549/549							
		280/271A00	37.6/50.0	104.2/120.3	176.9/176.9	163/181	524/524	191.6/191.6	200/200	176/195	544/544	200/200	168/187	529/529	197.6/197.6	200/200	168/187	529/529	197.6/197.6	200/200	182/200	549/549							
		281/272A00	56.3/75.0	156.4/180.4	227.0/227.0	223/250	524/524	241.8/241.8	250/250	236/264	544/544	250/250	228/256	529/529	247.8/247.8	250/300	228/256	529/529	247.8/247.8	250/300	242/269	549/549							
STD		NONE	-	-	36	193	41.0	50	205	37.0	45	43	205	195	39	45	39	195	43.2	50	46	207							
		282/273A00	25.0	30.1	42.4	39	193	50.1	60	205	45.1	50	46	205	195	42	50	42	52.9	60	49	207							
		283/274A00	50.0	60.1	64.9	73	193	72.6	80	205	67.6	80	81	205	195	76	80	76	75.4	80	83	207							
		284/275A00	75.0	90.2	95.0	108	193	102.7	110	205	97.7	100	115	205	195	111	100	111	105.5	110	118	207							
MED		NONE	-	-	43	212	46.9	60	224	42.9	50	50	224	214	46	50	46	214	49.1	60	53	226							
		282/273A00	25.0	30.1	49.8	46	212	57.5	60	224	52.5	60	53	224	214	48	60	48	60.3	70	55	226							
		283/274A00	50.0	60.1	72.2	80	212	80.0	90	224	75.0	80	83	224	214	83	80	83	82.7	90	90	226							
		284/275A00	75.0	90.2	102.3	115	212	110.1	125	224	105.1	125	122	224	214	117	125	117	112.8	125	125	226							
HIGH		NONE	-	-	48	249	51.1	60	261	47.1	60	55	261	251	50	60	50	251	53.3	60	57	263							
		282/273A00	25.0	30.1	54.8	50	249	62.5	70	261	57.5	60	58	261	251	53	60	53	65.3	70	60	263							
		283/274A00	50.0	60.1	77.2	85	249	85.0	90	261	80.0	90	92	261	251	87	90	87	87.7	90	95	263							
		284/275A00	75.0	90.2	107.3	119	249	115.1	125	261	110.1	125	127	261	251	122	125	122	117.8	125	129	263							
ULTRA		NONE	-	-	51	269	55.1	60	281	51.1	60	59	281	271	54	60	54	271	57.3	70	61	283							
		282/273A00	25.0	30.1	58.8	54	269	66.5	70	281	61.5	70	61	281	271	57	70	57	69.3	70	64	283							
		283/274A00	50.0	60.1	81.2	89	269	89.0	100	281	84.0	100	96	281	271	91	100	91	91.7	100	98	283							
		284/275A00	75.0	90.2	111.3	123	269	119.1	125	281	114.1	125	130	281	271	126	125	126	121.8	125	133	283							

See "Legend and Notes for Tables 21 and 22" on page 92.

**Table 22 - Unit Wire Sizing Data with Factory-Installed HACR Breaker (cont)**

UNIT	NO. M. V.-Ph-HZ	ELEC. HTR				NO. C.O. or UNIPWR C.O.																			
		CRHEATER***A00 VERT/HORZ	Nom (kW)	FLA	NO P.E.				w/ P.E. (pwrd fr/unit)				NO P.E.				w/ P.E. (pwrd fr/unit)								
					MCA	HACR BRKR	FLA	LRA	DISC. SIZE	MCA	HACR BRKR	FLA	LRA	DISC. SIZE	MCA	HACR BRKR	FLA	LRA	DISC. SIZE	MCA	HACR BRKR	FLA	LRA	DISC. SIZE	
STD		NONE	-	-	30.0	40	32	154	162	37	40	34.8	40	40	37	162	31.7	40	33	156	36.5	45	45	39	164
		285/276A00	24.8	23.9	35.5	40	33	154	162	38	45	41.5	45	45	38	162	37.6	40	35	156	43.6	45	45	40	164
		286/277A00	49.6	47.7	65.3	70	60	154	162	66	80	71.3	80	80	66	162	67.4	70	62	156	73.4	80	80	68	164
		287/278A00	74.4	71.6	77.2	90	88	154	162	93	90	83.2	90	90	93	162	79.4	90	89	156	85.4	90	90	95	164
MED		NONE	-	-	32.7	40	35	166	174	40	45	37.5	45	40	174	34.4	40	37	168	39.2	45	45	42	176	
		285/276A00	24.8	23.9	38.9	40	36	166	174	41	45	44.9	45	45	41	174	41.0	45	38	168	47.0	50	50	43	176
		286/277A00	49.6	47.7	68.6	70	63	166	174	69	80	74.6	80	80	69	174	70.8	80	65	168	76.8	80	80	71	176
		287/278A00	74.4	71.6	80.6	90	91	166	174	96	90	86.6	90	90	96	174	82.7	90	93	168	88.7	90	90	98	176
HIGH		NONE	-	-	34.4	40	37	193	201	42	45	39.2	45	42	201	36.1	45	39	195	40.9	50	50	44	203	
		285/276A00	24.8	23.9	41.0	45	38	193	201	43	50	47.0	50	45	43	201	43.1	45	40	195	49.1	50	50	45	203
		286/277A00	49.6	47.7	70.8	80	65	193	201	71	80	76.8	80	80	71	201	72.9	80	67	195	78.9	80	80	73	203
		287/278A00	74.4	71.6	82.7	90	93	193	201	98	90	88.7	90	90	98	201	84.9	90	95	195	90.9	100	100	100	203
ULTRA		NONE	-	-	38.7	50	41	204	212	46	50	43.5	50	46	212	40.4	50	43	206	45.2	50	50	48	214	
		285/276A00	24.8	23.9	45.6	50	42	204	212	47	60	51.6	60	60	47	212	47.8	50	44	206	53.8	60	60	49	214
		286/277A00	49.6	47.7	75.4	80	69	204	212	75	90	81.4	90	90	75	212	77.5	80	71	206	83.5	90	90	77	214
		287/278A00	74.4	71.6	87.4	100	97	204	212	102	100	93.4	100	100	102	212	89.5	100	99	206	95.5	100	100	104	214

See "Legend and Notes for Tables 21 and 22" on page 92.

**Table 22 - Unit Wire Sizing Data with Factory-Installed HACR Breaker (cont)**

UNIT	NO M. V.-Ph-HZ	ELEC. HTR				NO C.O. or UNPWR C.O.												w/ PWRD C.O.											
		IFM TYPE	CRHEATER/A00 VERT/HORZ	Nom (kW)	FLA	NO P.E.				w/ P.E. (pwrd fr/unit)				NO P.E.				w/ P.E. (pwrd fr/unit)											
						MCA	HACR BRKR	FLA	LRA	DISC. SIZE	MCA	HACR BRKR	FLA	LRA	DISC. SIZE	MCA	HACR BRKR	FLA	LRA	DISC. SIZE									
STD		NONE	-	-	-	73.3/73.3	100/100	76/75	412	412	9089	432	82/81	417	89.9/89.9	100/100	95/95	437											
		279/270A00	18.8/25.0	52.1/60.1	84.9/84.9	100/100	76/78	412/412	412/412	99.6/99.6	100/100	90/92	432/432	82/84	417/417	105.6/105.6	110/110	95/97	437/437										
		280/271A00	37.6/50.0	104.2/120.3	141.0/141.0	150/150	130/147	412/412	412/412	155.8/155.8	175/175	143/161	432/432	135/153	417/417	161.8/161.8	175/175	149/166	437/437										
		281/272A00	56.3/75.0	156.4/180.4	190.2/190.2	200/200	190/216	412/412	412/412	204.9/204.9	225/225	203/230	432/432	195/222	417/417	210.9/210.9	225/225	209/236	437/437										
MED		NONE	-	-	-	85.9	100	91	451	451	104	471	96	456	102.5	125	110	476											
		279/270A00	18.8/25.0	52.1/60.1	101.6/101.6	110/110	91/93	451/451	451/451	116.4/116.4	125/125	104/107	471/471	96/99	456/456	122.4/122.4	125/125	110/113	476/476										
		280/271A00	37.6/50.0	104.2/120.3	156.8/156.8	175/175	144/163	451/451	451/451	171.5/171.5	175/175	158/176	471/471	150/168	456/456	177.5/177.5	200/200	163/182	476/476										
		281/272A00	56.3/75.0	156.4/180.4	206.9/206.9	225/250	204/232	451/451	451/451	221.7/221.7	225/250	218/245	471/471	210/237	456/456	227.7/227.7	250/250	223/251	476/476										
HIGH		NONE	-	-	-	92.8	100	99	525	525	112	545	104	530	109.4	125	118	550											
		279/270A00	18.8/25.0	52.1/60.1	110.1/110.1	125/125	99/101	525/525	525/525	124.9/124.9	125/125	112/115	545/545	104/107	530/530	130.9/130.9	150/150	118/120	550/550										
		280/271A00	37.6/50.0	104.2/120.3	165.3/165.3	175/175	152/171	525/525	525/525	180.0/180.0	200/200	166/184	545/545	158/176	530/530	186.0/186.0	200/200	171/190	550/550										
		281/272A00	56.3/75.0	156.4/180.4	215.4/215.4	225/250	212/240	525/525	525/525	230.2/230.2	250/250	226/253	545/545	218/245	530/530	236.2/236.2	250/250	231/259	550/550										
ULTRA		NONE	-	-	-	104.4	125	109	565	565	123	585	115	570	121.0	150	128	590											
		279/270A00	18.8/25.0	52.1/60.1	121.8/121.8	125/125	109/112	565/565	565/565	136.5/136.5	150/150	123/126	585/585	115/118	570/570	142.5/142.5	150/150	128/131	590/590										
		280/271A00	37.6/50.0	104.2/120.3	176.9/176.9	200/200	163/181	565/565	565/565	191.6/191.6	200/200	176/195	585/585	168/187	570/570	197.6/197.6	200/200	182/200	590/590										
		281/272A00	56.3/75.0	156.4/180.4	227.0/227.0	250/250	223/250	565/565	565/565	241.8/241.8	250/250	236/264	585/585	228/256	570/570	247.8/247.8	250/300	242/269	590/590										
STD		NONE	-	-	-	37.2	50	39	231	231	46	243	42	233	45.6	50	49	245											
		282/273A00	25.0	30.1	42.4	50	39	231	231	50.1	60	46	243	42	233	52.9	60	49	245										
		283/274A00	50.0	60.1	64.9	70	73	231	231	72.6	80	81	243	76	233	75.4	80	83	245										
		284/275A00	75.0	90.2	95.0	100	108	231	231	102.7	110	115	243	111	233	105.5	110	118	245										
MED		NONE	-	-	-	43.1	50	46	250	250	53	262	48	252	51.5	60	56	264											
		282/273A00	25.0	30.1	49.8	50	46	250	250	57.5	60	53	262	48	252	60.3	70	56	264										
		283/274A00	50.0	60.1	72.2	80	80	250	250	80.0	90	87	262	83	252	82.7	90	90	264										
		284/275A00	75.0	90.2	102.3	125	115	250	250	110.1	125	122	262	117	252	112.8	125	125	264										
HIGH		NONE	-	-	-	47.3	60	50	287	287	58	299	53	289	55.7	60	60	301											
		282/273A00	25.0	30.1	54.8	60	50	287	287	62.5	70	58	299	53	289	65.3	70	60	301										
		283/274A00	50.0	60.1	77.2	90	85	287	287	85.0	90	92	299	87	289	87.7	90	95	301										
		284/275A00	75.0	90.2	107.3	125	119	287	287	115.1	125	127	299	122	289	117.8	125	129	301										
ULTRA		NONE	-	-	-	51.3	60	54	307	307	61	319	57	309	59.7	70	64	321											
		282/273A00	25.0	30.1	58.8	60	54	307	307	66.5	70	61	319	57	309	69.3	70	64	321										
		283/274A00	50.0	60.1	81.2	90	89	307	307	89.0	100	96	319	91	309	91.7	100	98	321										
		284/275A00	75.0	90.2	111.3	125	123	307	307	119.1	125	130	319	126	309	121.8	125	133	321										

See "Legend and Notes for Tables 21 and 22" on page 92.

**Table 22 - Unit Wire Sizing Data with Factory-Installed HACR Breaker (cont)**

UNIT	NO. M. V.-Ph-HZ	IFM TYPE	ELEC. HTR			NO. C.O. or UNIPWR C.O.															
			CRHEATER™A00 VERT/HORZ	Nom (kW)	FLA	NO P.E.				w/ P.E. (pwrd fr/unit)				NO P.E.				w/ P.E. (pwrd fr/unit)			
						MCA	HACR BRKR	FLA	LRA	DISC. SIZE	MCA	HACR BRKR	FLA	LRA	DISC. SIZE	MCA	HACR BRKR	FLA	LRA	DISC. SIZE	MCA
STD			NONE	-	-	34	182	36.6	45	39	190	33.5	40	36	184	38.3	45	41	192		
			285/276A00	24.8	23.9	34	182	41.5	45	39	190	37.6	40	36	184	43.6	45	41	192		
			286/277A00	49.6	47.7	60	182	71.3	80	66	190	67.4	70	62	184	73.4	80	68	192		
			287/278A00	74.4	71.6	88	182	83.2	90	93	190	79.4	90	89	184	85.4	90	95	192		
MED			NONE	-	-	37	194	39.3	45	42	202	36.2	45	39	196	41.0	50	44	204		
			285/276A00	24.8	23.9	37	194	44.9	45	42	202	41.0	45	39	196	47.0	50	44	204		
			286/277A00	49.6	47.7	63	194	74.6	80	69	202	70.8	80	65	196	76.8	80	71	204		
			287/278A00	74.4	71.6	91	194	86.6	90	96	202	82.7	90	93	196	88.7	90	98	204		
HIGH			NONE	-	-	39	221	41.0	50	44	229	37.9	45	41	223	42.7	50	46	231		
			285/276A00	24.8	23.9	39	221	47.0	50	44	229	43.1	45	41	223	49.1	50	46	231		
			286/277A00	49.6	47.7	65	221	76.8	80	71	229	72.9	80	67	223	78.9	80	73	231		
			287/278A00	74.4	71.6	93	221	88.7	90	98	229	84.9	90	95	223	90.9	100	100	231		
ULTRA			NONE	-	-	43	232	45.3	50	48	240	42.2	50	45	234	47.0	60	50	242		
			285/276A00	24.8	23.9	43	232	51.6	60	48	240	47.8	50	45	234	53.8	60	50	242		
			286/277A00	49.6	47.7	69	232	81.4	90	75	240	77.5	80	71	234	83.5	90	77	242		
			287/278A00	74.4	71.6	97	232	93.4	100	102	240	89.5	100	99	234	95.5	100	104	242		

See "Legend and Notes for Tables 21 and 22" on page 92.



**Table 22 - Unit Wire Sizing Data with Factory-Installed HACR Breaker (cont)**

UNIT	NO M. V.-Ph-HZ	ELEC. HTR				NO C.O. or UNPWR C.O.												w/ PWRD C.O.											
		IFM TYPE	CRHEATER/A00 VERT/HORZ	Nom (kW)	FLA	NO P.E.				w/ P.E. (pwrd ft/unit)				NO P.E.				w/ P.E. (pwrd ft/unit)											
						MCA	HACR BRKR	FLA	LIRA	DISC. SIZE	MCA	HACR BRKR	FLA	LIRA	DISC. SIZE	MCA	HACR BRKR	FLA	LIRA	DISC. SIZE									
STD		NONE	-	-	-	101.9	125	108	538	113.7	125	121	588	106.7	125	113	543	118.5	150	127	563	127/127	127/127	563/563					
		279/270A00	18.8/25.0	52.1/60.1	101.9/101.9	125/125	108/108	538/538	116.4/116.4	125/125	121/121	588/588	107.6/107.6	125/125	113/113	543/543	122.4/122.4	150/150	127/127	127/127	563/563	127/127	127/127	563/563					
		280/271A00	37.6/50.0	104.2/120.3	156.8/156.8	175/175	144/163	538/538	171.5/171.5	175/175	158/176	588/588	162.8/162.8	175/175	150/168	543/543	177.5/177.5	200/200	163/182	163/182	563/563	163/182	163/182	563/563					
		281/272A00	56.3/75.0	156.4/180.4	206.9/206.9	225/250	204/232	538/538	221.7/221.7	225/250	218/245	588/588	212.9/212.9	225/250	210/237	543/543	227.7/227.7	250/250	223/251	223/251	563/563	223/251	223/251	563/563					
MED	208/230-3-60	NONE	-	-	-	101.9	125	108	538	113.7	125	121	588	106.7	125	113	543	118.5	150	127	563	127/127	127/127	563/563					
		279/270A00	18.8/25.0	52.1/60.1	101.9/101.9	125/125	108/108	538/538	116.4/116.4	125/125	121/121	588/588	107.6/107.6	125/125	113/113	543/543	122.4/122.4	150/150	127/127	127/127	563/563	127/127	127/127	563/563					
		280/271A00	37.6/50.0	104.2/120.3	156.8/156.8	175/175	144/163	538/538	171.5/171.5	175/175	158/176	588/588	162.8/162.8	175/175	150/168	543/543	177.5/177.5	200/200	163/182	163/182	563/563	163/182	163/182	563/563					
		281/272A00	56.3/75.0	156.4/180.4	206.9/206.9	225/250	204/232	538/538	221.7/221.7	225/250	218/245	588/588	212.9/212.9	225/250	210/237	543/543	227.7/227.7	250/250	223/251	223/251	563/563	223/251	223/251	563/563					
HIGH		NONE	-	-	-	108.7	125	115	612	120.5	150	129	632	113.5	125	121	617	125.3	150	135	637	135/135	135/135	637/637					
		279/270A00	18.8/25.0	52.1/60.1	110.1/110.1	125/125	115/115	612/612	124.9/124.9	150/150	129/129	632/632	116.1/116.1	125/125	121/121	617/617	130.9/130.9	150/150	135/135	135/135	637/637	135/135	135/135	637/637					
		280/271A00	37.6/50.0	104.2/120.3	165.3/165.3	175/175	152/171	612/612	180.0/180.0	200/200	166/184	632/632	171.3/171.3	175/175	158/176	617/617	186.0/186.0	200/200	171/190	171/190	637/637	171/190	171/190	637/637					
		281/272A00	56.3/75.0	156.4/180.4	215.4/215.4	225/250	212/240	612/612	230.2/230.2	250/250	226/253	632/632	221.4/221.4	225/250	218/245	617/617	236.2/236.2	250/250	231/259	231/259	637/637	231/259	231/259	637/637					
ULTRA	50LC-024	NONE	-	-	-	119.0	150	126	652	130.8	150	140	672	123.8	150	132	657	135.6	150	145	677	145/145	145/145	677/677					
		279/270A00	18.8/25.0	52.1/60.1	121.8/121.8	150/150	126/126	652/652	136.5/136.5	150/150	140/140	672/672	127.8/127.8	150/150	132/132	657/657	142.5/142.5	150/150	145/145	145/145	677/677	145/145	145/145	677/677					
		280/271A00	37.6/50.0	104.2/120.3	176.9/176.9	200/200	163/181	652/652	191.6/191.6	200/200	176/195	672/672	182.9/182.9	200/200	168/187	657/657	197.6/197.6	200/200	182/200	182/200	677/677	182/200	182/200	677/677					
		281/272A00	56.3/75.0	156.4/180.4	227.0/227.0	250/250	223/250	652/652	241.8/241.8	250/250	236/264	672/672	233.0/233.0	250/250	228/256	657/657	247.8/247.8	250/300	242/269	242/269	677/677	242/269	242/269	677/677					
STD		NONE	-	-	-	56.6	70	60	278	62.8	80	67	290	58.8	70	62	280	65.0	80	70	292	70/70	70/70	292/292					
		282/273A00	25.0	30.1	56.6	70	60	278	62.8	80	67	290	58.8	70	62	280	65.0	80	70	292	70/70	70/70	292/292						
		283/274A00	50.0	60.1	72.2	80	80	278	80.0	90	87	290	75.0	80	83	280	82.7	90	90	292	90/90	90/90	292/292						
		284/275A00	75.0	90.2	102.3	125	115	278	110.1	125	122	290	105.1	125	117	280	112.8	125	125	292	125/125	125/125	292/292						
MED	460-3-60	NONE	-	-	-	56.6	70	60	278	62.8	80	67	290	58.8	70	62	280	65.0	80	70	292	70/70	70/70	292/292					
		282/273A00	25.0	30.1	56.6	70	60	278	62.8	80	67	290	58.8	70	62	280	65.0	80	70	292	70/70	70/70	292/292						
		283/274A00	50.0	60.1	72.2	80	80	278	80.0	90	87	290	75.0	80	83	280	82.7	90	90	292	90/90	90/90	292/292						
		284/275A00	75.0	90.2	102.3	125	115	278	110.1	125	122	290	105.1	125	117	280	112.8	125	125	292	125/125	125/125	292/292						
HIGH		NONE	-	-	-	60.6	70	65	315	66.8	80	72	327	62.8	80	67	317	69.0	80	74	329	74/74	74/74	329/329					
		282/273A00	25.0	30.1	60.6	70	65	315	66.8	80	72	327	62.8	80	67	317	69.0	80	74	329	74/74	74/74	329/329						
		283/274A00	50.0	60.1	77.2	90	85	315	85.0	90	92	327	80.0	90	87	317	87.7	90	95	329	95/95	95/95	329/329						
		284/275A00	75.0	90.2	107.3	125	119	315	115.1	125	127	327	110.1	125	122	317	117.8	125	129	329	129/129	129/129	329/329						
ULTRA		NONE	-	-	-	63.8	80	68	335	70.0	80	75	347	66.0	80	71	337	72.2	80	78	349	78/78	78/78	349/349					
		282/273A00	25.0	30.1	63.8	80	68	335	70.0	80	75	347	66.0	80	71	337	72.2	80	78	349	78/78	78/78	349/349						
		283/274A00	50.0	60.1	81.2	90	89	335	89.0	100	96	347	84.0	100	91	337	91.7	100	98	349	98/98	98/98	349/349						
		284/275A00	75.0	90.2	111.3	125	123	335	119.1	125	130	347	114.1	125	126	337	121.8	125	133	349	133/133	133/133	349/349						

See "Legend and Notes for Tables 21 and 22" on page 92.

**Table 22 - Unit Wire Sizing Data with Factory-Installed HACR Breaker (cont)**

UNIT	NO. M. V.-Ph-HZ	IFM TYPE	ELEC. HTR			NO. C.O. or UNIPWR C.O.															
			CRHEATER™A00 VERT/HORZ	Nom (kW)	FLA	NO P.E.			w/ P.E. (pwrd fr/unit)			NO P.E.			w/ P.E. (pwrd fr/unit)						
						MCA	HACR BRKR	DISC. SIZE FLA LRA	MCA	HACR BRKR	DISC. SIZE FLA LRA	MCA	HACR BRKR	DISC. SIZE FLA LRA	MCA	HACR BRKR	DISC. SIZE FLA LRA				
STD			NONE	-	-	45.0	50	48	206	49.8	60	54	214	46.7	50	50	208	51.5	60	56	216
			285/276A00	24.8	23.9	45.0	50	48	206	49.8	60	54	214	46.7	50	50	208	51.5	60	56	216
			286/277A00	49.6	47.7	68.6	70	63	206	74.6	80	69	214	70.8	80	65	208	76.8	80	71	216
			287/278A00	74.4	71.6	80.6	90	91	206	86.6	90	96	214	82.7	90	93	208	88.7	90	98	216
MED			NONE	-	-	45.0	50	48	206	49.8	60	54	214	46.7	50	50	208	51.5	60	56	216
			285/276A00	24.8	23.9	45.0	50	48	206	49.8	60	54	214	46.7	50	50	208	51.5	60	56	216
			286/277A00	49.6	47.7	68.6	70	63	206	74.6	80	69	214	70.8	80	65	208	76.8	80	71	216
			287/278A00	74.4	71.6	80.6	90	91	206	86.6	90	96	214	82.7	90	93	208	88.7	90	98	216
HIGH			NONE	-	-	46.7	50	50	233	51.5	60	56	241	48.4	60	52	235	53.2	60	58	243
			285/276A00	24.8	23.9	46.7	50	50	233	51.5	60	56	241	48.4	60	52	235	53.2	60	58	243
			286/277A00	49.6	47.7	70.8	80	65	233	76.8	80	71	241	72.9	80	67	235	78.9	80	73	243
			287/278A00	74.4	71.6	82.7	90	93	233	88.7	90	98	241	84.9	90	95	235	90.9	100	100	243
ULTRA			NONE	-	-	50.4	60	54	244	55.2	60	60	252	52.1	60	56	246	56.9	70	62	254
			285/276A00	24.8	23.9	50.4	60	54	244	55.2	60	60	252	52.1	60	56	246	56.9	70	62	254
			286/277A00	49.6	47.7	75.4	80	69	244	81.4	90	75	252	77.5	80	71	246	83.5	90	77	254
			287/278A00	74.4	71.6	87.4	100	97	244	93.4	100	102	252	89.5	100	99	246	95.5	104	104	254

See "Legend and Notes for Tables 21 and 22" on page 92.

**Table 22 - Unit Wire Sizing Data with Factory-Installed HACR Breaker (cont)**

UNIT	NO M. V.-Ph-HZ	IFM TYPE	ELEC. HTR			NO C.O. or UNPWR C.O.												w/ PWRD C.O.											
			CRHEATER-A00 VERT/HORZ	Nom (kW)	FLA	NO P.E.				w/ P.E. (pwrd ft/unit)				NO P.E.				w/ P.E. (pwrd ft/unit)											
						MCA	HACR BRKR	FLA	LIRA	DISC. SIZE	MCA	HACR BRKR	FLA	LIRA	DISC. SIZE	MCA	HACR BRKR	FLA	LIRA	DISC. SIZE	MCA	HACR BRKR	FLA	LIRA	DISC. SIZE				
STD			NONE	-	-	129	629	142	649	129.7	175	134	634	129.7	175	134	634	129.7	175	134	634	141.5	175	148	654				
			279/270A00	18.8/25.0	52.1/60.1	129/129	629/629	142/142	649/649	136.7/136.7	175/175	134/134	634/634	136.7/136.7	175/175	134/134	634/634	136.7/136.7	175/175	134/134	634/634	141.5/141.5	175/175	148/148	654/654				
			280/271A00	37.6/50.0	104.2/120.3	144/163	629/629	158/176	649/649	171.5/171.5	175/175	150/168	634/634	171.5/171.5	175/175	150/168	634/634	171.5/171.5	175/175	150/168	634/634	177.5/177.5	200/200	163/182	654/654				
			281/272A00	56.3/75.0	156.4/180.4	204/232	629/629	218/245	649/649	221.7/221.7	225/250	210/237	634/634	221.7/221.7	225/250	210/237	634/634	221.7/221.7	225/250	210/237	634/634	227.7/227.7	250/250	223/251	654/654				
MED	208/230-3-60		NONE	-	-	137	703	150	723	136.5	175	142	708	136.5	175	142	708	136.5	175	142	708	148.3	175	156	728				
			279/270A00	18.8/25.0	52.1/60.1	137/137	703/703	150/150	723/723	143.5/143.5	175/175	142/142	708/708	143.5/143.5	175/175	142/142	708/708	143.5/143.5	175/175	142/142	708/708	148.3/148.3	175/175	156/156	728/728				
			280/271A00	37.6/50.0	104.2/120.3	152/171	703/703	166/184	723/723	180.0/180.0	200/200	166/184	723/723	180.0/180.0	200/200	166/184	723/723	180.0/180.0	200/200	166/184	723/723	186.0/186.0	200/200	171/190	728/728				
			281/272A00	56.3/75.0	156.4/180.4	212/240	703/703	226/253	723/723	230.2/230.2	250/250	226/253	723/723	230.2/230.2	250/250	226/253	723/723	230.2/230.2	250/250	226/253	723/723	236.2/236.2	250/250	231/259	728/728				
HIGH			NONE	-	-	147	743	161	763	145.8	200	153	748	145.8	200	153	748	145.8	200	153	748	157.6	200	167	768				
			279/270A00	18.8/25.0	52.1/60.1	147/147	743/743	161/161	763/763	152.8/152.8	200/200	161/161	763/763	152.8/152.8	200/200	161/161	763/763	152.8/152.8	200/200	161/161	763/763	157.6/157.6	200/200	167/167	768/768				
			280/271A00	37.6/50.0	104.2/120.3	163/181	743/743	176/195	763/763	191.6/191.6	200/200	176/195	763/763	191.6/191.6	200/200	176/195	763/763	191.6/191.6	200/200	176/195	763/763	197.6/197.6	200/200	182/200	768/768				
			281/272A00	56.3/75.0	156.4/180.4	223/250	743/743	241.8/241.8	763/763	241.8/241.8	250/250	241.8/241.8	763/763	241.8/241.8	250/250	241.8/241.8	763/763	241.8/241.8	250/250	241.8/241.8	763/763	247.8/247.8	250/300	242/269	768/768				
STD			NONE	-	-	68	322	75	334	67.1	90	70	324	67.1	90	70	324	67.1	90	70	324	73.3	90	78	336				
			282/273A00	25.0	30.1	68	322	75	334	71.1	90	75	334	71.1	90	75	334	71.1	90	75	334	73.3	90	78	336				
			283/274A00	50.0	60.1	80	322	87	334	80.0	90	87	334	80.0	90	87	334	80.0	90	87	334	82.7	90	90	336				
			284/275A00	75.0	90.2	115	322	122	334	110.1	125	122	334	110.1	125	122	334	110.1	125	122	334	112.8	125	125	336				
MED	460-3-60		NONE	-	-	73	359	80	371	71.1	90	75	361	71.1	90	75	361	71.1	90	75	361	77.3	90	82	373				
			282/273A00	25.0	30.1	73	359	80	371	75.1	90	80	371	75.1	90	80	371	75.1	90	80	371	77.3	90	82	373				
			283/274A00	50.0	60.1	85	359	96	371	85.0	100	96	371	85.0	100	96	371	85.0	100	96	371	87.7	100	95	373				
			284/275A00	75.0	90.2	119	359	127	371	115.1	125	127	371	115.1	125	127	371	115.1	125	127	371	117.8	125	129	373				
HIGH			NONE	-	-	76	379	83	391	74.3	100	79	381	74.3	100	79	381	74.3	100	79	381	80.5	100	86	393				
			282/273A00	25.0	30.1	76	379	83	391	78.3	100	83	391	78.3	100	83	391	78.3	100	83	391	80.5	100	86	393				
			283/274A00	50.0	60.1	89	379	99	391	89.0	100	99	391	89.0	100	99	391	89.0	100	99	391	91.7	100	98	393				
			284/275A00	75.0	90.2	123	379	130	391	119.1	125	130	391	119.1	125	130	391	119.1	125	130	391	117.8	125	133	393				
STD			NONE	-	-	56	235	62	243	55.6	70	58	237	55.6	70	58	237	55.6	70	58	237	60.4	80	64	245				
			285/276A00	24.8	23.9	56	235	62	243	58.7	70	62	243	58.7	70	62	243	58.7	70	62	243	60.4	80	64	245				
			286/277A00	49.6	47.7	63	235	69	243	74.6	80	69	243	74.6	80	69	243	74.6	80	69	243	76.8	80	71	245				
			287/278A00	74.4	71.6	91	235	96	243	86.6	90	96	243	86.6	90	96	243	86.6	90	96	243	88.7	90	98	245				
MED	575-3-60		NONE	-	-	58	262	64	270	60.4	80	64	270	60.4	80	64	270	60.4	80	64	270	62.1	80	66	272				
			285/276A00	24.8	23.9	58	262	64	270	60.4	80	64	270	60.4	80	64	270	60.4	80	64	270	62.1	80	66	272				
			286/277A00	49.6	47.7	65	262	71	270	76.8	80	71	270	76.8	80	71	270	76.8	80	71	270	78.9	80	73	272				
			287/278A00	74.4	71.6	93	262	98	270	88.7	90	98	270	88.7	90	98	270	88.7	90	98	270	90.9	100	100	272				
HIGH			NONE	-	-	62	273	68	281	61.0	80	64	275	61.0	80	64	275	61.0	80	64	275	65.8	80	70	283				
			285/276A00	24.8	23.9	62	273	68	281	64.1	80	68	281	64.1	80	68	281	64.1	80	68	281	65.8	80	70	283				
			286/277A00	49.6	47.7	69	273	75	281	81.4	90	75	281	81.4	90	75	281	81.4	90	75	281	83.5	90	77	283				
			287/278A00	74.4	71.6	97	273	102	281	93.4	100	102	281	93.4	100	102	281	93.4	100	102	281	95.5	100	104	283				

See "Legend and Notes for Tables 21 and 22" on page 92.

## Legend and Notes for Tables 21 and 22

### LEGEND:

BRKR	-	Circuit breaker
C.O.	-	Convenience outlet
DISC.	-	Disconnect
FLA	-	Full load amps
LRA	-	Locked rotor amps
MCA	-	Minimum circuit amps
PE.	-	Power exhaust
Pwr'd fr/ unit	-	Powered from unit
PWRD C.O.	-	Powered convenience outlet
UNPWR C.O.	-	Unpowered convenience outlet

### NOTES:

- In compliance with NEC requirements for multimotor and combination load equipment (refer to NEC Articles 430 and 440), the overcurrent protective device for the unit shall be fuse or HACR breaker. Canadian units may be fuse or circuit breaker.
- For 208/230 v units, where one value is shown it is the same for either 208 or 230 volts.
- Unbalanced 3-Phase Supply Voltage**  
Never operate a motor where a phase imbalance in supply voltage is greater than 2%. Use the following formula to determine the percentage of voltage imbalance.

$$\% \text{ Voltage Imbalance} = 100 \times \frac{\text{max voltage deviation from average voltage}}{\text{average voltage}}$$

Example: Supply voltage is 230-3-60



AB = 224 v  
BC = 231 v  
AC = 226 v

$$\text{Average Voltage} = \frac{(224 + 231 + 226)}{3} = \frac{681}{3} = 227$$

Determine maximum deviation from average voltage.

(AB) 227 - 224 = 3 v

(BC) 231 - 227 = 4 v

(AC) 227 - 226 = 1 v

Maximum deviation is 4 v.

Determine percent of voltage imbalance.

$$\% \text{ Voltage Imbalance} = 100 \times \frac{4}{227} = 1.76\%$$

This amount of phase imbalance is satisfactory as it is below the maximum allowable 2%.

**IMPORTANT:** If the supply voltage phase imbalance is more than 2%, contact your local electric utility company immediately.

## Smoke Detectors

Smoke detectors are available as factory-installed options on 50LC 14-26 models. Smoke detectors may be specified for Supply Air only or for Return Air without or with economizer or in combination of Supply Air and Return Air. The unit is factory-configured for immediate smoke detector shutdown operation; additional wiring or modifications to unit's Integrated Staging Control (ISC) board may be necessary to complete the unit and smoke detector configuration to meet project requirements.

### Return Air Sensor Tube Installation –

The return air sampling tube is shipped in the unit's supply fan section, attached to the blower housing (see Fig. 64). Its operating location is in the return air section of the unit (see Fig. 65, unit without economizer, or Fig. 66, unit with economizer), inserted into the return air sensor module housing which protrudes through the back of the control box.

### To install the return air sensor sampling tube:

- Remove the tube from its shipping location.
- Open the unit end to access the return air sensor (located on right-hand partition)

- Orient the tube's sampling holes into the return air flow direction. For vertical application, position the sampling holes on the bottom of the tube, facing into the bottom return duct opening. For horizontal application, position the sampling holes on the side of the tube, facing the unit's end panel.
- Insert the sampling tube into the return air sensor module until the tube snaps into position.
- Replace end panel or outside air hood.

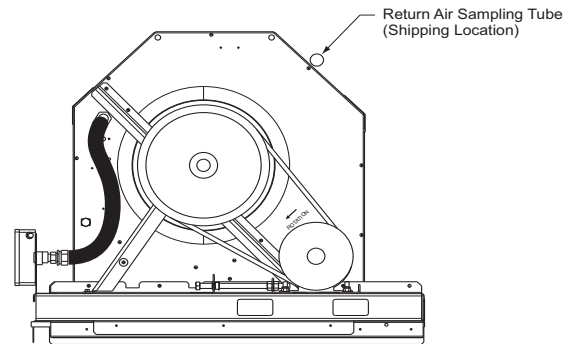

C09102

**Fig. 64 - Typical Supply Air Smoke Detector Sensor Location**

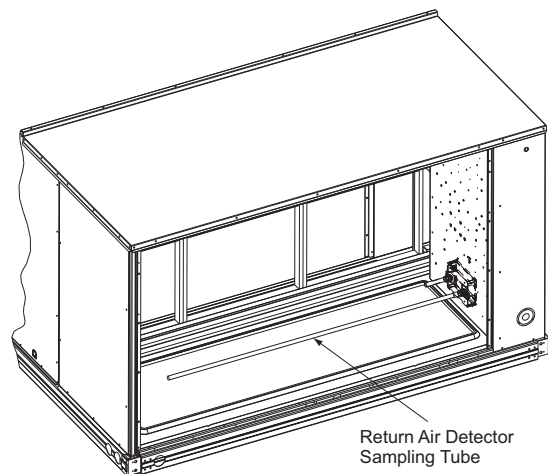

C09135

**Fig. 65 - Return Air Sampling Tube Location in Unit without Economizer**

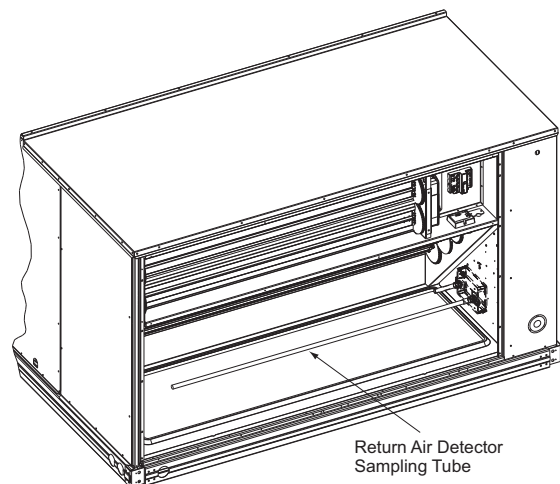

C09136

**Fig. 66 - Return Air Sampling Tube Location in Unit with Economizer**

**Smoke Detector Test Magnet —**

Locate the magnet; it is shipped in the control box area.

**Additional Application Data —**

Refer to *Factory Installed Smoke Detectors for Small and Medium Rooftop Units 2 to 25 Tons* for discussions on additional control features of these smoke detectors including multiple unit coordination.

**Step 11 — Install Accessories**

Available accessories include:

- Roof Curb (must be installed before unit)
- Electric heaters
- EconoMi\$er® X (with control)
- Power Exhaust
- Outdoor enthalpy sensor
- Differential enthalpy sensor
- CO<sub>2</sub> sensor
- Temperature and Humidity sensors
- Louvered hail guard
- Phase monitor control

Refer to separate installation instructions for information on installing these accessories. See Price Pages for a complete list of field-installed accessories.

**Step 12 — Check Belt Tension**

Measure the belt span length as shown in Fig. 67. Calculate the required deflection by multiplying the belt span length by 1/64. For example, if the belt span length is 32 inches: 32 x 1/64 = 1/2 inch deflection.

**Belt Force - Deflection Method -**

Check the belt tension with a spring-force belt force deflection gauge.

1. Place a straightedge along the belt between the two pulleys. Measure the distance between the motor shaft and the blower shaft.
2. Set the tension gauge to the desired tension (see Table 1 in Fig. 67). Place the large O-ring at that point.
3. Press the tension checker downward on the belt until the large O-ring is at the bottom of the straightedge.
4. Adjust the belt tension as needed.

Adjust belt tension by loosening the motor mounting plate front bolts and rear bolt (see Fig. 68 on page 94) and sliding the plate towards the fan (to reduce tension) or away from the fan (to increase tension). Ensure the blower shaft and motor shaft are parallel to each other (pulleys aligned). Tighten all bolts securely when finished.

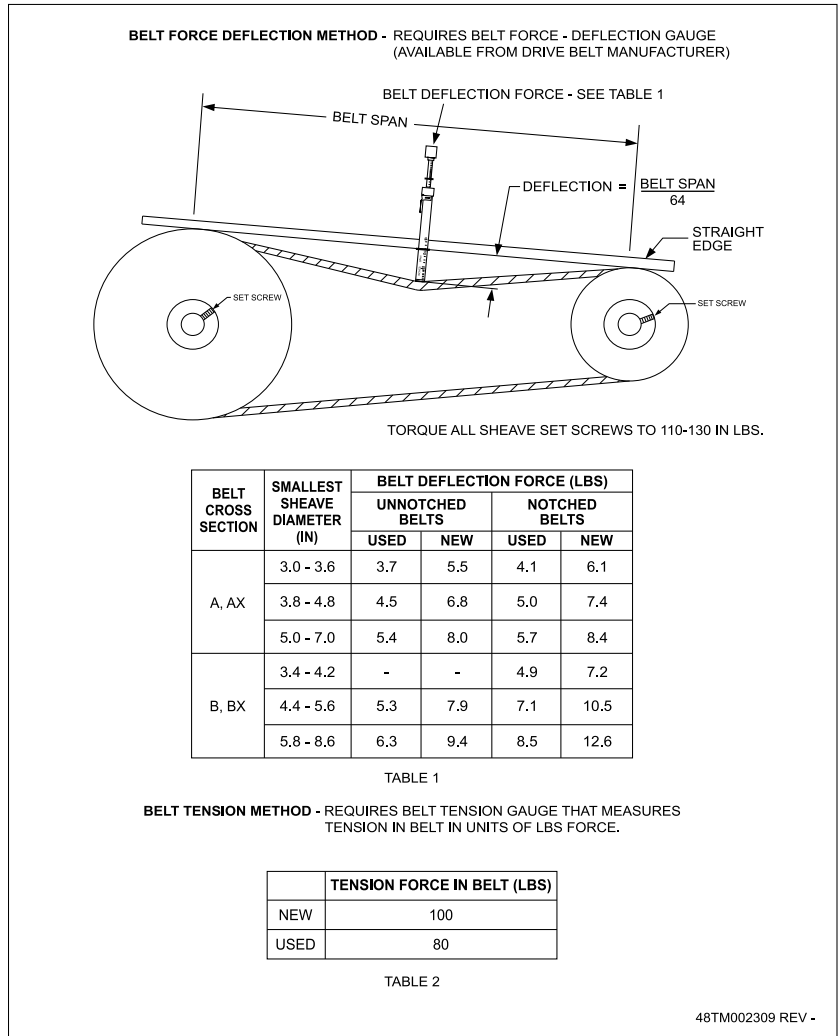

**Fig. 67 - V-Belt Force Label**

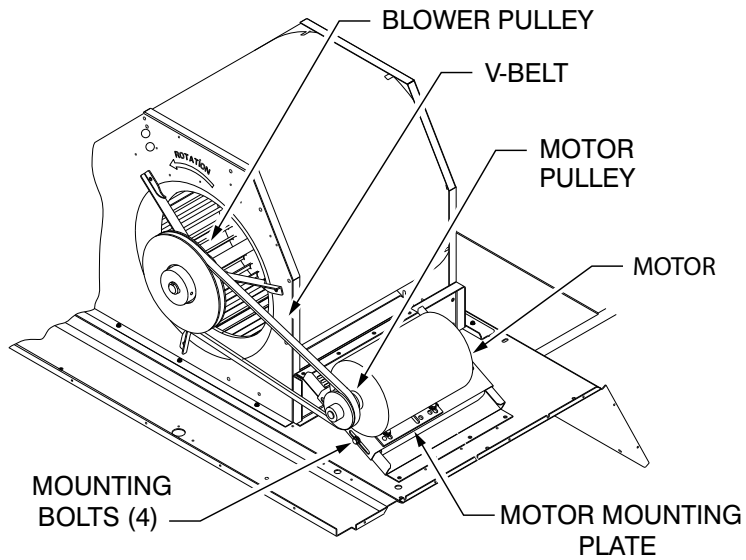

**Fig. 68 - Belt Drive Motor Mounting**

C11504

**Pre-Start and Start-Up**

This completes the mechanical installation of the unit. Refer to the unit's Service and Maintenance manual for detailed Pre-Start and Start-up instructions.

# UNIT START-UP CHECKLIST

(Remove and Store in Job File)

**NOTE: To avoid injury to personnel and damage to equipment or property when completing the procedures listed in this start-up checklist, use good judgement, follow safe practices, and adhere to the safety considerations/information as outlined in the preceding sections of this Installation Instructions document.**

MODEL NO.: \_\_\_\_\_

SERIAL NO.: \_\_\_\_\_

## I. PRE-START-UP

- VERIFY THAT ALL PACKAGING MATERIALS HAVE BEEN REMOVED FROM UNIT
- VERIFY INSTALLATION OF OUTDOOR AIR HOOD
- VERIFY THAT CONDENSATE CONNECTION IS INSTALLED PER INSTRUCTIONS
- VERIFY THAT ALL ELECTRICAL CONNECTIONS AND TERMINALS ARE TIGHT
- CHECK THAT INDOOR-AIR FILTERS ARE CLEAN AND IN PLACE
- CHECK THAT OUTDOOR AIR INLET SCREENS ARE IN PLACE
- VERIFY THAT UNIT IS LEVEL
- CHECK FAN WHEELS AND PROPELLER FOR LOCATION IN HOUSING/ORIFICE AND VERIFY SETSCREW IS TIGHT
- VERIFY THAT FAN SHEAVES ARE ALIGNED AND BELTS ARE PROPERLY TENSIONED
- VERIFY THAT SCROLL COMPRESSORS ARE ROTATING IN THE CORRECT DIRECTION
- VERIFY INSTALLATION OF THERMOSTAT

## II. START-UP

### ELECTRICAL

SUPPLY VOLTAGE	L1-L2 _____	L2-L3 _____	L3-L1 _____
COMPRESSOR AMPS 1	L1 _____	L2 _____	L3 _____
COMPRESSOR AMPS 2	L1 _____	L2 _____	L3 _____
SUPPLY FAN AMPS	L1 _____	L2 _____	L3 _____

### TEMPERATURES

OUTDOOR-AIR TEMPERATURE \_\_\_\_\_ °F DB (DRY BULB)

RETURN-AIR TEMPERATURE \_\_\_\_\_ °F DB \_\_\_\_\_ °F WB (WET BULB)

COOLING SUPPLY AIR TEMPERATURE \_\_\_\_\_ °F

### PRESSURES

REFRIGERANT SUCTION	CIRCUIT A _____	PSIG
	CIRCUIT B _____	PSIG
REFRIGERANT DISCHARGE	CIRCUIT A _____	PSIG
	CIRCUIT B _____	PSIG

- VERIFY REFRIGERANT CHARGE USING CHARGING CHARTS

### GENERAL

- ECONOMIZER MINIMUM VENT AND CHANGEOVER SETTINGS TO JOB REQUIREMENTS (IF EQUIPPED)
- VERIFY SMOKE DETECTOR UNIT SHUTDOWN BY UTILIZING MAGNET TEST

### III. HUMIDI-MIZER<sup>®</sup> SYSTEM START-UP

**NOTE:** Units equipped with either SystemVu™ or RTU-Open controls have Service Test menus or modes that can assist with the Humidi-MiZer System Start-Up function and provide the means to make the observations listed for this start-up.

#### STEPS

- 1. CHECK CTB FOR JUMPER 5, 6, 7  
JUMPER 5, 6, 7 MUST BE CUT AND OPEN
- 2. OPEN HUMIDISTAT CONTACTS
- 3. START UNIT IN COOLING (CLOSE Y1)

#### OBSERVE AND RECORD

- A. SUCTION PRESSURE \_\_\_\_\_ PSIG \_\_\_\_\_ PSIG
  - B. DISCHARGE PRESSURE \_\_\_\_\_ PSIG \_\_\_\_\_ PSIG
  - C. ENTERING AIR TEMPERATURE \_\_\_\_\_ °F \_\_\_\_\_ °F
  - D. LIQUID LINE TEMPERATURE  
AT OUTLET OR REHEAT COIL \_\_\_\_\_ °F \_\_\_\_\_ °F
  - E. CONFIRM CORRECT ROTATION FOR COMPRESSOR
  - F. CHECK FOR CORRECT RAMP-UP OF OUTDOOR FAN MOTOR AS CONDENSER COIL WARMS
- 4. CHECK UNIT CHARGE PER CHARGING CHART
  - 5. SWITCH UNIT TO HIGH-LATENT MODE (SUBCOOLER) BY CLOSING HUMIDISTAT WITH Y1 CLOSED

#### OBSERVE

- A. REDUCTION IN SUCTION PRESSURE (5 TO 7 PSI EXPECTED)
  - B. DISCHARGE PRESSURE UNCHANGED
  - C. LIQUID TEMPERATURE DROPS TO 50 TO 55°F RANGE
  - D. LSV SOLENOID ENERGIZED (VALVE CLOSSES)
- 6. SWITCH UNIT TO DEHUMID (REHEAT) BY OPENING Y1

#### OBSERVE

- A. SUCTION PRESSURE INCREASES TO NORMAL COOLING LEVEL
  - B. DISCHARGE PRESSURE DECREASES (35 TO 50 PSI)
  - C. LIQUID TEMPERATURE RETURNS TO NORMAL COOLING LEVEL
  - D. LIQUID SOLENOID VALVE (LSV) ENERGIZED (VALVE CLOSSES)
  - E. DISCHARGE SOLENOID VALVE (DSV) ENERGIZED, VALVE OPENS
- 7. WITH UNIT IN DEHUMID MODE CLOSE W1  
COMPRESSOR AND OUTDOOR FAN STOP; LSV AND DSV SOLENOIDS DE-ENERGIZED
  - 8. OPEN W1 RESTORE UNIT TO DEHUMID MODE
  - 9. OPEN HUMIDISTAT INPUT  
COMPRESSOR AND OUTDOOR FAN STOP; LSV AND DSV SOLENOIDS DE-ENERGIZED
  - 10. RESTORE SETPOINTS FOR THERMOSTAT AND HUMIDISTAT

### REPEAT PROCESS FOR 2 COMPRESSOR SYSTEMS