



WeatherExpert®
50N2,N3,N4,N5,N6,N7,N8,N9
Packaged Rooftop Cooling Units with Optional Electric
Heat or Hydronic Heat and ComfortLink Controls

Installation Instructions

CONTENTS

	Page
GENERAL	1
SAFETY CONSIDERATIONS	1
ACOUSTICAL CONSIDERATIONS	2
Location	2
Ductwork	2
Acoustic Insulation	2
INSTALLATION	3
Step 1 — Perform Job site Survey	3
Step 2 — Place Unit	3
Step 3 — Roof Mount Unit	3
• STEEL BEAMS	
• ROOF CURB	
Step 4 — Slab Mount Unit	3
Step 5 — Install Curb Gasketing	3
PHYSICAL DATA TABLES	5
OPERATING WEIGHTS OF OPTIONS AND ACCESSORIES	9
SUPPLY FAN AND DRIVE DATA	11
POWER EXHAUST FAN AND DRIVE DATA	11
ERV DRIVE SELECTION	12
REFRIGERANT CHARGE	12
ROOF CURB DRAWINGS & TABLES	13
ROOF CURB CONDENSER	25
UNIT SIZES DRAWINGS AND TABLES	26
Step 6 — Install Field-Fabricated Ductwork	50
Step 7 — Rig Unit	50
Step 8 — Connect Condensate Drain	50
Step 9 — Install Outdoor Air Hoods — Units without ERV	56
Step 10 — Install Exhaust Hoods — Units with ERV	58
• INSTALL EXHAUST HOODS — UNITS WITH ERV	
• INSTALL OUTDOOR AIR INTAKE HOODS — OPTIONAL ERV UNITS	
• INSTALL OUTDOOR AIR BYPASS AIR INTAKE HOODS — OPTIONAL ERV UNITS WITH OUTDOOR AIR INTAKE BYPASS	
Step 11 — Route Field Wiring	60
Step 12 — Make Field Electrical Connections	60
• POWER WIRING	
Step 13 — Connect Air Pressure Tubing	63
• VARIABLE FREQUENCY DRIVE	
• POWER EXHAUST	
• RETURN FAN	
Step 14 — Remove Supply-Fan Shipping Bracket Screws	63
Step 15 — Remove Power Exhaust Shipping Bracket Screws	63
Step 16 — Remove Optional Return-Fan Shipping Brackets	63
Step 17 — Remove Optional ERV Shipping Bracket	63

Step 18 — Remove Optional Return-Fan Shipping Brackets	65
Step 19 — Install Supply-Air Thermistors	65
Step 20 — Install Unit Accessories	65
Wheel Air Seal Adjustment	67
Two-Piece Unit Fit Up	68
CONTROLS INSTALLATION	72
Constant Volume (CV)/Staged Air Volume (SAV™) Units	72
• CONTROL WIRING	
Variable Air Volume (VAV) Units	73
Option and Accessory Control Wiring	73
Carrier Comfort Network® (CCN) Interface	79
Optional UPC Open Installation	79
Smoke Control Modes	81

GENERAL

This installation instruction contains basic unit installation information, including installation of thermostats and remote temperature sensors.

For additional information and service instructions, refer to the Controls, Start-Up, Operation, Service, and Troubleshooting manual.

SAFETY CONSIDERATIONS

Installation and servicing of air-conditioning equipment can be hazardous due to system pressure and electrical components. Only trained and qualified service personnel should install, repair, or service air-conditioning equipment.

Untrained personnel can perform basic maintenance functions of cleaning coils and filters and replacing filters. All other operations should be performed by trained service personnel. When working on air-conditioning equipment, observe precautions in the literature, tags and labels attached to the unit, and other safety precautions that may apply.

Follow all safety codes, including ANSI (American National Standards Institute) Z223.1. Wear safety glasses and work gloves. Use quenching cloth for unbrazing operations. Have fire extinguisher available for all brazing operations.

⚠ WARNING

Before performing service or maintenance operations on unit, turn off main power switch to unit. Electrical shock could cause personal injury.

FOR YOUR SAFETY

Do not store or use gasoline or other flammable vapors and liquids in the vicinity of this or any other appliance.

⚠ WARNING

Improper installation, adjustment, alteration, service, or maintenance can cause injury or property damage. Refer to this manual. For assistance or additional information, consult a qualified installer, service agency, or the gas supplier.

⚠ WARNING

DO NOT USE TORCH to remove any component. System contains oil and refrigerant under pressure.

To remove a component, wear protective gloves and goggles and proceed as follows:

- a. Shut off electrical power to unit.
- b. Recover refrigerant to relieve all pressure from system using both high-pressure and low pressure ports.
- c. Traces of vapor should be displaced with nitrogen and the work area should be well ventilated. Refrigerant in contact with an open flame produces toxic gases.
- d. Cut component connection tubing with tubing cutter and remove component from unit. Use a pan to catch any oil that may come out of the lines and as a gage for how much oil to add to the system.
- e. Carefully un-sweat remaining tubing stubs when necessary. Oil can ignite when exposed to torch flame.

Failure to follow these procedures may result in personal injury or death.

⚠ CAUTION

DO NOT re-use compressor oil or any oil that has been exposed to the atmosphere. Dispose of oil per local codes and regulations. **DO NOT** leave refrigerant system open to air any longer than the actual time required to service the equipment. Seal circuits being serviced and charge with dry nitrogen to prevent oil contamination when timely repairs cannot be completed. Failure to follow these procedures may result in damage to equipment.

ACOUSTICAL CONSIDERATIONS

In order to minimize sound transmitted to the space, please conform to the following recommendations (see Fig. 1):

Location

- Avoid locating the unit above sound sensitive areas. Instead, locate the unit above restrooms, storage areas, corridors, or other noise tolerant areas.
- Avoid mounting the unit in the middle of large roof expanses between vertical supports. This will minimize the phenomenon known as roof bounce.
- Install the units close to vertical roof supports (columns or load bearing walls).
- Locate the units at least 25 feet away from critical areas. If this is not possible, the ductwork and ceiling structure should be acoustically treated.
- Consider the use of vibration isolators or an acoustic curb.

Ductwork

- Utilize flexible connectors between the unit and the supply and return ducts.
- Supply and return air main trunk ducts should be located over hallways and/or public areas.
- Provide trailing edge turning vanes in ductwork elbows and tees to reduce air turbulence.
- Make the ductwork as stiff as possible.
- Use round duct wherever possible because it is less noisy.
- Seal all penetrations around ductwork entering the space.
- Make sure that ceiling and wall contractors do not attach hangers or supports to ductwork.
- Provide as smooth and gradual transition as possible when connecting the rooftop unit discharge to the supply duct.
- If a ceiling plenum return is utilized, provide a return elbow or tee to eliminate line-of-sight noise to the space. Face the entrance of the return duct away from other adjacent units.

Acoustic Insulation

- Provide acoustic interior lining for first 20 feet of supply and return duct or until the first elbow is encountered. The elbow prevents line-of-sight transmission in the supply and return ducts.
- Install a double layer of 2-in. low density quilted fiberglass acoustical pad with a 1/8-in. barium-loaded vinyl facing on top of the roof deck before building insulation and roofing installation occur. Place the material inside the curb and for 4 to 8 ft beyond the unit perimeter, dependent upon unit size (larger units require a wider apron outside the curb). Openings in the pad should only be large enough for the supply and return ducts. An alternate approach is to use two layers of gypsum board with staggered seams in addition to the acoustical pad.

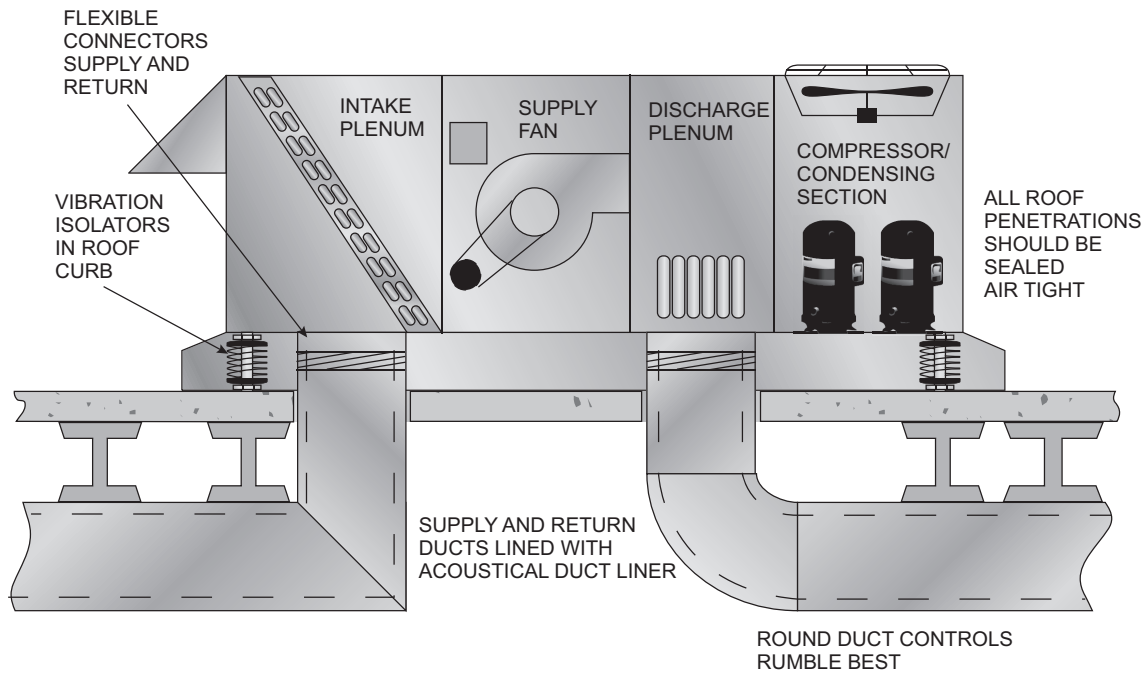

Fig. 1 — Acoustical Considerations

INSTALLATION

Step 1 — Perform Job Site Survey — Complete the following checks before installation.

1. Consult local building codes and the NEC (National Electrical Code) (ANSI/NFPA [American National Standards Institute/National Fire Protection Association] 70) for special installation requirements.
2. Determine unit location (from project plans) or select unit location. Refer to Acoustical Considerations section.
3. Check for possible overhead obstructions which may interfere with unit lifting or rigging.

CAUTION

Do not lift unit with forklift truck. Move unit with overhead rigging only.

Step 2 — Place Unit — Inspect unit for transportation damage. If any damage is found file a claim with the transportation agency.

Provide clearance around and above unit for airflow, safety, and service access. Do not restrict top (area above condenser fans) in any way. Allow at least 6 ft on all sides for rated performance, code compliance, and service. On units equipped with power exhaust option, high velocity air is exhausted out the hood. Unit should be positioned with at least 10 ft clearance between the exhaust hood and any obstruction. See Fig. 2 for multiple unit minimum spacing.

Check unit dimensional drawings on pages 13-49 (Fig. 4-22) for unit arrangement and minimum performance and service clearances. See Tables 1-7 for additional unit data.

Do not install unit in an indoor location. Do not locate air inlets near exhaust vents or other sources of contaminated air.

Although unit is weatherproof, guard against water from higher level runoff and overhangs.

Level by using unit frame as a reference.

Step 3 — Roof Mount Unit — Check building codes for weight distribution requirements. Unit and accessory weights are shown in Tables 1 and 2. Unit may be mounted on class A, B, or C roofing material.

STEEL BEAMS — If roof curb is not used, support unit with steel beams along its entire length and then support steel as required. Cross members are required to support across its width at each lifting lug location; use more cross members for support as needed. See Fig. 3.

ROOF CURB — Assemble and install roof curb as described in instructions shipped with the accessory. Refer to Acoustical Considerations section. Accessory roof curb and information required to field fabricate a roof curb is shown in Fig. 4 and 5. Install insulation, cant strips, roofing and counter flashing as required. For unit condensate drain to function properly, curb must be level or within tolerances shown in Fig. 4.

NOTE: Units with double-wall floor design (“Double Wall on-the-bottom”) are not compatible with roof curbs.

Step 4 — Slab Mount Unit — Provide a level concrete slab that extends beyond unit cabinet at least 6 inches. Use gravel apron in front of condenser coil air inlet to prevent grass and foliage from obstructing airflow. Provide a slab minimum 8-in. thick with sufficient height above grade to allow for condensate trap as described in Step 8.

Step 5 — Install Curb Gasketing — After ductwork has been connected to the roof curb, apply gasket material (1/2-in. thick x 1 1/2-in. wide neoprene) where indicated.

Single-Thickness Gasketing (See Fig. 23 for Item Numbers) — Apply gasketing in the following places:

1. Along both side rails (1) — 2 places, full length
2. Along return air end rail (2) — 1 place
3. Around return air internal duct flange (3) — 1 or 2 places
4. Around supply air internal duct flanges (4) — 3 places
5. Along supply section base rail (5) — 1 place

Condenser Section Roof Curb (See Fig. 24) — Apply single-thickness gasket along both side rails (5).

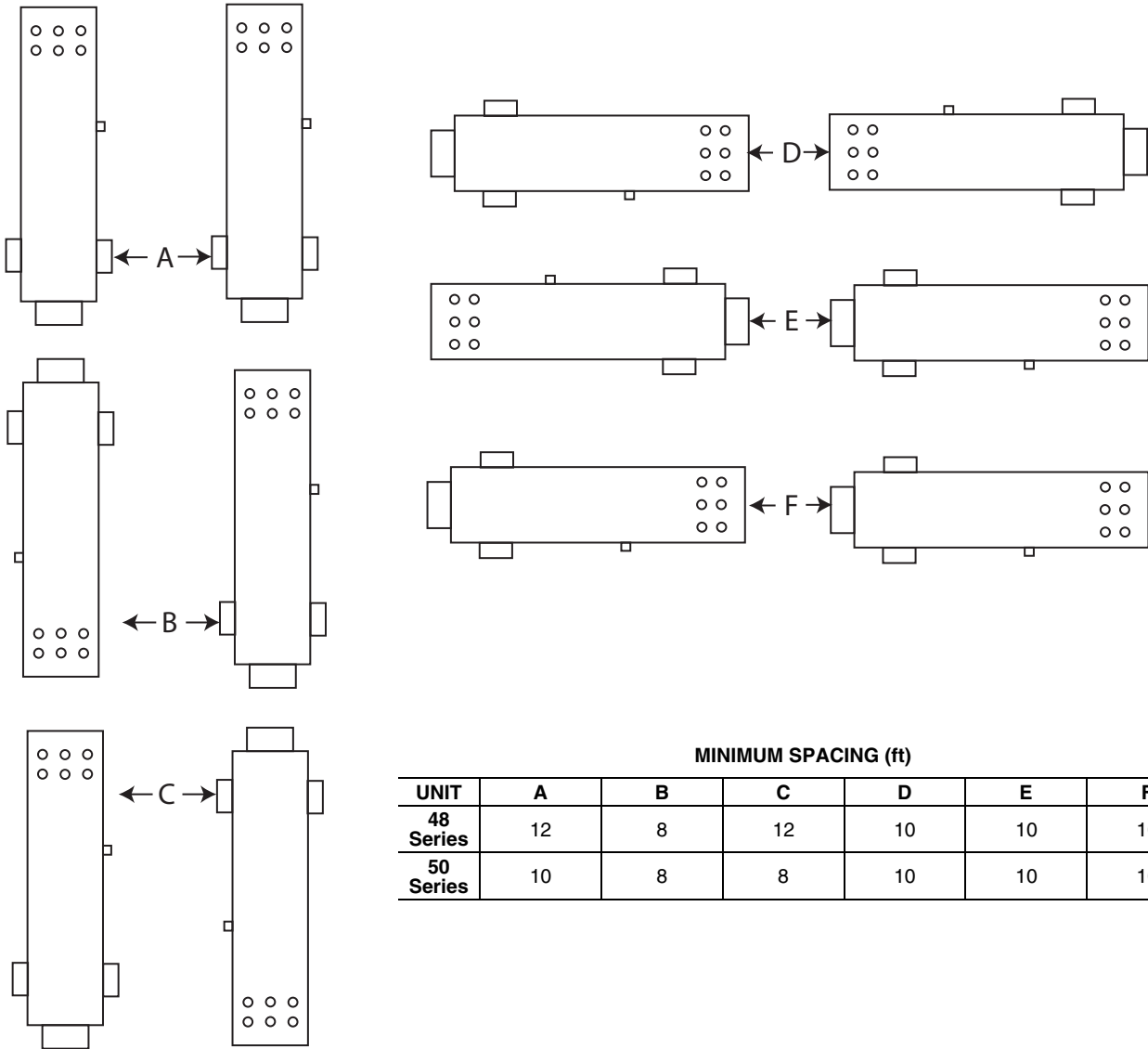

MINIMUM SPACING (ft)						
UNIT	A	B	C	D	E	F
48 Series	12	8	12	10	10	10
50 Series	10	8	8	10	10	10

Fig. 2 — Multiple Unit Minimum Separation

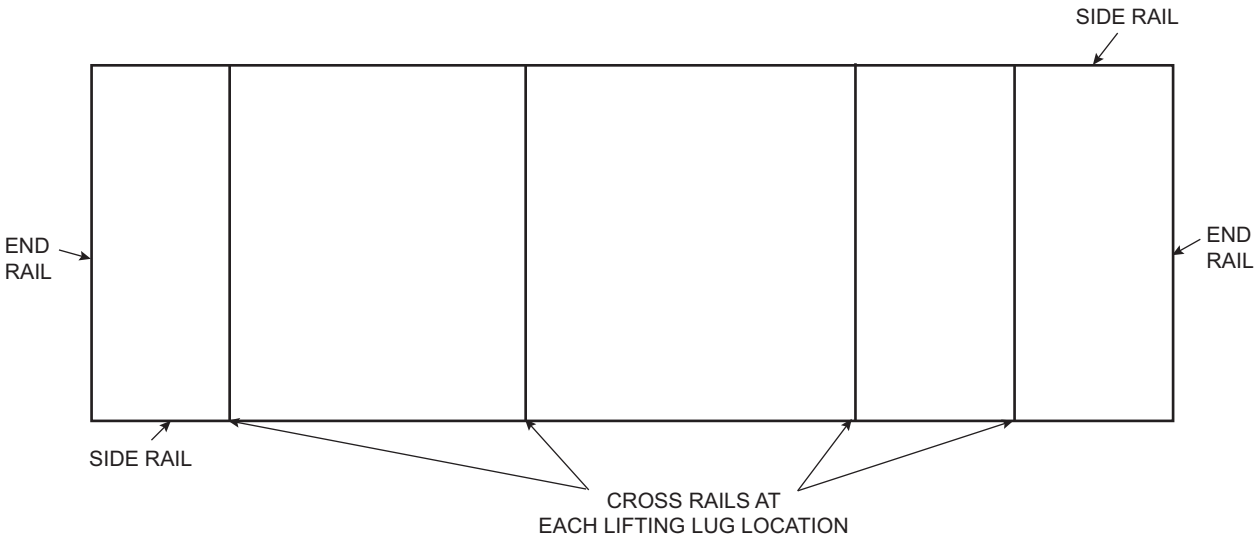

Fig. 3 — Steel Beam Mounting

Table 1 — Physical Data 50N — (75-150 Tons Nominal Capacity)

BASE UNIT (Model Number - Pos. 6) †	N	P	Q	R	S	T
NOMINAL CAPACITY (tons)	75	90	105	120	130	150
WEIGHT (lb)						
Base Unit *	12,000	12,455	12,455	16,170	16,860	17,040
Split Unit - Main Section	9,110	9,565	9,565	12,880	13,570	13,750
Split Unit - Return Section	2,890	2,890	2,890	3,290	3,290	3,290
COMPRESSORS				Scroll		
Quantity	5	6	6	8	8	8
Oil Charge (oz) per Compressor	110	110	110	110	110	110
Compressor A1	ZP182	ZP154	ZP182	ZP182	ZP154	ZP182
Compressor A2	ZP182	ZP154	ZP182	ZP154	ZP182	ZP182
Compressor A3	0	ZP154	ZP182	ZP154	ZP182	ZP182
Compressor A4	0	0	0	ZP154	ZP182	ZP182
Compressor B1	ZP137	ZP182	ZP182	ZP182	ZP154	ZP182
Compressor B2	ZP137	ZP182	ZP182	ZP154	ZP182	ZP182
Compressor B3	ZP137	ZP182	ZP182	ZP154	ZP182	ZP182
Compressor B4	0	0	0	ZP154	ZP182	ZP182
Stages of Capacity, % Total Capacity	0,18,23,41,65,82,100	0,11,15,33,49,67,82,100	0,13,17,33,50,67,83,100	0,11,14,28,40,52,64,76,88,100	0,8,11,22,35,48,61,74,87,100	0,9,13,25,38,50,63,75,88,90
Number of Refrigerant Circuits	2	2	2	2	2	2
REFRIGERANT				R-410A		
Type				See Table 7		
Charge Amount						
METERING DEVICE				Electronically controlled expansion devices... two (2) per circuit		
Type... Quantity per Circuit						
STANDARD EFFICIENCY UNIT CONDENSER				MCHX		
Material	Aluminum	Aluminum	Aluminum	Aluminum	Aluminum	Aluminum
Number of Total Coils	4	4	4	4	6	6
Total Face Area (sq ft)	138.7	173.3	173.3	173.3	173.3	260.0
HIGH EFFICIENCY UNIT CONDENSER				MCHX		
Material	Aluminum	Aluminum	Aluminum	Aluminum	Aluminum	NA
Number of Total Coils	4	6	6	6	6	
Total Face Area (sq ft)	138.7	173.3	260.0	260.0	260.0	
EVAP-STANDARD CAPACITY with STD EFFICIENCY				RTPF		
Material	CU-AL	CU-AL	CU-AL	CU-AL	CU-AL	CU-AL
Quantity	2	2	2	2	2	2
Tube Type	Cross Hatched	Cross Hatched	Cross Hatched	Cross Hatched	Cross Hatched	Cross Hatched
Rows (each)	4	4	6	4	6	6
FPI	16	16	16	16	16	16
Total Face Area (sq ft)	78.8	78.8	78.8	99.6	99.6	99.6
EVAP-STANDARD CAPACITY with HIGH EFF				RTPF		
Material	CU-AL	CU-AL	CU-AL	CU-AL	CU-AL	NA
Quantity	2	2	2	2	2	
Tube Type	Cross Hatched	Cross Hatched	Cross Hatched	Cross Hatched	Cross Hatched	
Rows (each)	4	4	6	4	6	
FPI	16	16	16	16	16	
Total Face Area (sq ft)	78.8	78.8	78.8	99.6	99.6	
EVAP-HIGH CAPACITY with STD EFFICIENCY				RTPF		
Material	CU-AL	CU-AL	CU-AL	CU-AL	CU-AL	CU-AL
Quantity	2	2	2	2	2	2
Tube Type	Cross Hatched	Cross Hatched	Cross Hatched	Cross Hatched	Cross Hatched	Cross Hatched
Rows (each)	6	6	8	6	8	8
FPI	16	16	16	16	16	16
Total Face Area (sq ft)	78.8	78.8	78.8	99.6	99.6	99.6
EVAP-HIGH CAPACITY with HIGH EFFICIENCY				RTPF		
Material	CU-AL	CU-AL	CU-AL	CU-AL	CU-AL	NA
Quantity	2	2	2	2	2	
Tube Type	Cross Hatched	Cross Hatched	Cross Hatched	Cross Hatched	Cross Hatched	
Rows (each)	6	6	8	6	8	
FPI	16	16	16	16	16	
Total Face Area (sq ft)	78.8	78.8	78.8	99.6	99.6	

LEGEND

- Cu-Al** — Copper-to-Aluminum
- DWDI** — Double Width, Double Input
- FPI** — Fins per Inch
- MCHX** — Microchannel Heat Exchanger
- RTPF** — Round Tube Plate Fin
- SWSI** — Single Width, Single Input

* Base unit includes: economizer dampers and hoods, filter tracks less filters, evaporator coil mounting less the evaporator, extended plenum, and standard efficiency condenser. For 75-105 nominal ton units only, base unit weight also includes the short supply fan section.

†

50	N2	D	N	6	0	Option Code
50 - Cooling Only Unit						Factory Options
Configuration						Design Revision Level
Heat* and Chassis Options						Voltage Options
						1 - 575-3-60 6 - 460-3-60
Unit Size - Nominal Tons						
N - 75		Q - 105		S - 130		
P - 90		R - 120		T - 150		

Table 1 — Physical Data 50N — (75-150 Tons Nominal Capacity) (cont)

BASE UNIT (MODEL NUMBER - POS. 6) †	N	P	Q	R	S	T
NOMINAL CAPACITY (tons)	75	90	105	120	130	150
CONDENSER FAN, STANDARD EFFICIENCY						
Number of Fans	4	6	6	6	9	9
Type	Prop/Metal	Prop/Metal	Prop/Plastic	Prop/Plastic	Prop/Metal	Prop/Plastic
Diameter (in.)	30.5	30	30.5	30.5	30	30.5
Motor Hp	1	1	1	1	1	1
Nominal Cfm	41,000	81,000	81,000	81,000	93,000	122,400
Motor Rpm	1140	1140	1140	1140	1140	1140
CONDENSER FAN, HIGH EFFICIENCY						
Number of Fans	6	9	9	9	9	NA
Type	Prop/Metal	Prop/Plastic	Prop/Plastic	Prop/Plastic	Prop/Plastic	
Diameter (in.)	30.5	30.5	30.5	30.5	30.5	
Motor Hp	1	1	1	1	1	
Nominal Cfm	61,000	93,000	93,000	93,000	93,000	
Motor Rpm	1140	1140	1140	1140	1140	
HUMIDI-MIZER® COIL						
Type	MCHX					
Material	Aluminum					
Quantity	1					
Surface	E-Coated					
Total Face Area (sq ft)	34.5	43	43	43	43	43
STANDARD AND HIGH CAPACITY HOT WATER COILS						
Type	RTPF					
Material	Aluminum Fin, Copper Tube					
Quantity	2					
Tube Type	Smooth					
Rows (each)	2					
FPI	12					
Total Face Area (sq ft)	22.4			26.4		
STANDARD AND HIGH CAPACITY STEAM COIL						
Type	RTPF					
Material	Aluminum Fin, Copper Tube, Steel Header, Sloped Casing					
Quantity	2					
Tube Type	Smooth					
Connection Size, Length (in.)	2.50, 3.00					
Total Face Area (sq ft)	40.1			49.0		
SUPPLY FAN						
Standard Supply Fan						
Diameter (in.)	28			32		
Wheel and Blade Type	DWDI Airfoil			DWDI Airfoil		
Maximum Allowable Cfm	42,000			60,000		
Maximum Allowable Speed (rpm)	1,800			1,550		
Shaft Diameter at Pulley (in.)	2.25			2.5		
High Static Supply Fan						
Diameter (in.)	40			40		
Wheel and Blade Type	DWDI Airfoil			DWDI Airfoil		
Maximum Allowable Cfm	52,500			60,000		
Maximum Allowable Speed (rpm)	1,250			1,250		
Shaft Diameter at Pulley (in.)	3			3		

LEGEND

- Cu-Al** — Copper-to-Aluminum
- DWDI** — Double Width, Double Input
- FPI** — Fins per Inch
- MCHX** — Microchannel Heat Exchanger
- RTPF** — Round Tube Plate Fin
- SWSI** — Single Width, Single Input

* Base unit includes: economizer dampers and hoods, filter tracks less filters, evaporator coil mounting less the evaporator, extended plenum, and standard efficiency condenser. For 75-105 nominal ton units only, base unit weight also includes the short supply fan section.

†

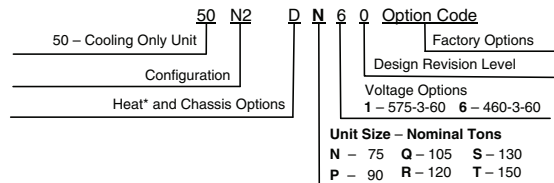

Table 1 — Physical Data 50N — (75-150 Tons Nominal Capacity) (cont)

BASE UNIT (MODEL NUMBER - POS. 6) †	N	P	Q	R	S	T
NOMINAL CAPACITY (tons)	75	90	105	120	130	150
OPTIONAL POWER EXHAUST						
Power Exhaust						
Diameter (in.)	20			23		
Wheel and Blade Type	DWDI Forward Curve			DWDI Forward Curve		
Maximum Allowable Cfm	42,000			60,000		
Maximum Allowable Speed (Rpm)	1,200			1,200		
Shaft Diameter at Pulley (in.)	1.75			1.75		
High Static Power Exhaust						
Diameter (in.)		36			40	
Wheel and Blade Type		DWDI Forward Curve			DWDI Forward Curve	
Maximum Allowable Cfm		42,000			60,000	
Maximum Allowable Speed (Rpm)		650			600	
Shaft Diameter at Pulley (in.)		2.5			3	
OPTIONAL RETURN FAN						
Return Fan						
Diameter (in.)		40			40	
Wheel and Blade Type		SWSI Plenum Airfoil			SWSI Plenum Airfoil	
Maximum Allowable Cfm		52,500			60,000	
Maximum Allowable Speed (Rpm)		1236			1236	
Shaft Diameter at Pulley (in.)		2.5			2.5	
High Static Return Fan						
Diameter (in.)	45	50			56	
Wheel and Blade Type				SWSI Plenum Airfoil		
Maximum Allowable Cfm	60,000	60,000			60,000	
Maximum Allowable Speed (Rpm)	850	780			720	
Shaft Diameter at Pulley (in.)				3		
MIXED AIR FILTERS						
MERV 7 Pleated Filters						
Quantity		2 inch, MERV 7			2 inch, MERV 7	
Size (in.)		28			28	
		20x24x2			20x25x2	
MERV 8 Pleated Filters						
Quantity		4 inch, MERV 8			4 inch, MERV 8	
Size (in.)		28			28	
		20x24x4			20x25x4	
MERV 14 Pleated Filters						
Quantity		4 inch, MERV 14			4 inch, MERV 14	
Size (in.)		28			28	
		20x24x4			20x25x4	
MERV 14 Cartridge Filters, 2 or 4-in. in Pre-Filters						
Quantity		12 inch, MERV 14 Cartridge Filters			12 inch, MERV 14 Cartridge Filters	
Size (in.)		20			20	
		(15) 20x24x12, (5) 24x24x12			24x24x12	
MERV 14 Bag, 2 or 4-in. in Pre-Filters						
Quantity		12 inch, MERV 14 Bag Filters			12 inch, MERV 14 Bag Filters	
Size (in.)		20			20	
		(15) 20x24x12, (5) 24x24x12			24x24x12	
MERV 15 Bag, 2 or 4-in. in Pre-Filters						
Quantity		19 inch, MERV 15 Bag Filters			19 inch, MERV 15 Bag Filters	
Size (in.)		20			20	
		(15) 20x24x19, (5) 24x24x19			24x24x19	
FINAL FILTERS						
MERV 14 Cartridge Filters, 2 or 4-in. in Pre-Filters						
Quantity		12 inch, MERV 14 Cartridge Filters			12 inch, MERV 14 Cartridge Filters	
Size (in.)		19			19	
		(14) 20x24x12, (5) 24x24x12			24x24x12	
MERV 15 Bag, 2 or 4-in. in Pre-Filters						
Quantity		19 inch, MERV 15 Bag Filters			19 inch, MERV 15 Bag Filters	
Size (in.)		19			19	
		(14) 20x24x19, (5) 24x24x19			24x24x19	
MERV 17 HEPA, 2 or 4-in. in Pre-Filters						
Quantity		12 inch, MERV 17 HEPA Filters, 99.99%			12 inch, MERV 17 HEPA Filters, 99.99%	
Size (in.)		19			19	
		(14) 24x12x12, (5) 24x24x12			24x24x12	
OUTSIDE AIR SCREENS						
Standard Hood (Motorized OA and Economizer Options)	Aluminum Frame, Permanent					
Quantity		12 Screens			16 Screens	
Size (in.)		16 7/8 x 31			16 7/8 x 31	

LEGEND

- Cu-Al** — Copper-to-Aluminum
- DWDI** — Double Width, Double Input
- FPI** — Fins per Inch
- MCHX** — Microchannel Heat Exchanger
- RTPF** — Round Tube Plate Fin
- SWSI** — Single Width, Single Input

†

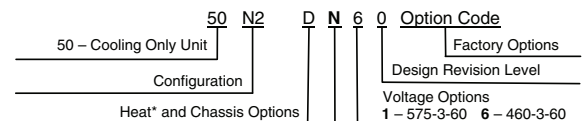

* Base unit includes: economizer dampers and hoods, filter tracks less filters, evaporator coil mounting less the evaporator, extended plenum, and standard efficiency condenser. For 75-105 nominal ton units only, base unit weight also includes the short supply fan section.

Unit Size - Nominal Tons

N - 75	Q - 105	S - 130
P - 90	R - 120	T - 150

Table 1 — Physical Data 50N — (75-150 Tons Nominal Capacity) (cont)

BASE UNIT (MODEL NUMBER - POS. 6) * †		N	P	Q	R	S	T	
NOMINAL CAPACITY (tons)		75	90	105	120	130	150	
Heat Exchanger Wheel	Low CFM	Quantity	2			2		
		Size (ea)	68" x 68"			78" x 78"		
		Part Number	ERC-6488C			ERC-74112C		
		No of Segments	8 (ea)			8 (ea)		
	High CFM	Quantity	2			2		
		Size (ea)	78" x 78"			86" x 86"		
		Part Number	ERC-74112C			ERC-81146C		
		No of Segments	8 (ea)			8 (ea)		
ERV Wheel Motor	Quantity	2						
	Hp	1/4						
	RPM	850						
	Type	Forward Curve - Class I						
Exhaust Air Blower	Low CFM	Diameter	25"					
		Part Number	A25-22H					
		Shaft Size	1-11/16"					
		Max RPM	790					
		Max CFM	17,000			26,000		
		Avail Motor Hp	5,7.5,10,15	7.5,10,15	7.5,10,15	7.5,10,15,20	10,15,20	10,15,20
		Type	Forward Curve - Class II			Forward Curve - Class II		
	High CFM	Diameter	25"			27"		
		Part Number	A25-22H			A27-22H		
		Shaft Size	2-7/16"			2-7/16"		
		Max RPM	1013			919		
		Max CFM	26,000			31,000		
Avail Motor Hp	10,15,20	15,20,25,30,40	15,20,25,30,40	20,25,30,40,50	20,25,30,40,50	20,25,30,40,50		
Outside Air Filters	Type (Standard) (Optional)	MERV 8			MERV 8			
		MERV 14			MERV 14			
	Size.... Qty	16" x 20" x 2"16			16" x 20" x 2"16			
Accessory Exhaust	Type	MERV 8			MERV 8			
Outside Air Filters	Type	MERV 14			MERV 14			
	Size.... Qty	24" x 24" x 4"9			24" x 24" x 4"9			
Outside Air Dampers	Qty	2			2			
	Size	35" x 70.8"			35" x 83.25"			
Optional By-Pass Dampers	Qty	2			2			
	Size	35" x 70.8"			35" x 83.25"			

LEGEND

- Cu-Al** — Copper-to-Aluminum
- DWDI** — Double Width, Double Input
- FPI** — Fins per Inch
- MCHX** — Microchannel Heat Exchanger
- RTPF** — Round Tube Plate Fin
- SWSI** — Single Width, Single Input

* Base unit includes: economizer dampers and hoods, filter tracks less filters, evaporator coil mounting less the evaporator, extended plenum, and standard efficiency condenser. For 75-105 nominal ton units only, base unit weight also includes the short supply fan section.

†

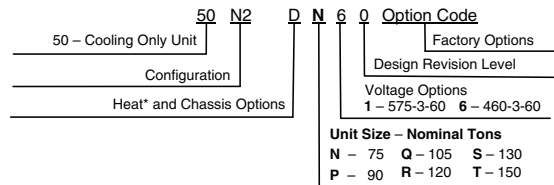

Table 2 — Operating Weights of Options and Accessories (lb)

OPTION OR ACCESSORY (FOR MODEL NUMBER POS. 6)	50N UNIT SIZE (TON NOMINAL CAPACITY)*					
	N (75)	P (90)	Q (105)	R (120)	S (130)	T (150)
Economizer	140	140	140	140	140	140
Filters						
2 in. MERV 7	90	90	90	100	100	100
4 in. MERV 8	150	150	150	175	175	175
4 in. MERV 14	175	175	175	210	210	210
12 in. MERV 14 Bag with 2 in. Pre-Filter	200	200	200	225	225	225
12 in. MERV 14 Bag with 4 in. Pre-Filter	260	260	260	300	300	300
19 in. MERV 15 Bag with 2 in. Pre-Filter	300	300	300	335	335	335
19 in. MERV 15 Bag with 4 in. Pre-Filter	320	320	320	350	350	350
12 in. MERV 14 Cartridge with 2 in. Pre-Filter	350	350	350	375	375	375
12 in. MERV 14 Cartridge with 4 in. Pre-Filter	370	370	370	400	400	400
Field Use Filter Section	635	635	635	665	665	665
Evaporator						
Standard Capacity	625	625	832	795	1053	1053
High Capacity	832	832	1110	1053	1402	1402
High-Efficiency Condenser	310	691	691	691	None	NA
Extended Chassis	320	320	320	335	335	335
Humidi-MiZer® Dehumidification System	475	495	495	510	510	510
Hot Water Coil						
Low Capacity	671	671	671	759	759	759
High Capacity	693	693	693	783	783	783
Steam Coil						
Low Capacity	837	940	940	1063	1063	1063
High Capacity	940	1043	1043	1187	1187	1187
Electric Heat						
Low	175	175	175	185	185	185
Medium	185	185	185	215	215	215
High	200	215	215	225	225	225
Blank Section						
4 ft	530	530	530	555	555	555
8 ft	1060	1060	1060	1110	1110	1110
Post Filters						
19 in. MERV 15 Bag with 2 in. Pre-Filter	830	830	830	890	890	890
19 in. MERV 15 Bag with 4 in. Pre-Filter	850	850	850	905	905	905
12 in. MERV 14 Cart with 2 in. Pre-Filter	880	880	880	930	930	930
12 in. MERV 14 Cart with 4 in. Pre-Filter	900	900	900	955	955	955
12 in. MERV 17 HEPA with 2 in. Pre-Filter	905	905	905	965	965	965
12 in. MERV 17 HEPA with 4 in. Pre-Filter	930	930	930	980	980	980
Supply Fan						
High-Static Supply Fan	1274	1274	1274	1169	1169	1169
Standard Supply Fan	965	965	965	1071	1071	1071
PE (Power Exhaust) Fan						
High-Static PE Fan	927	927	927	927	927	927
Standard PE Fan	619	727	727	727	727	727
Return Fan						
High-Static Return Fan	974	1086	1298	1298	1298	1298
Standard Return Fan	895	895	895	895	895	895
ERV Extra Length	593	593	593	655	655	655
ERV PE Fan						
Low ERV	250	250	250	250	250	250
High ERV	300	300	300	420	420	420
ERV Wheel						
Low ERV	688	688	688	908	908	908
High ERV	908	908	908	1160	1160	1160
ERV Intake Bypass Dampers	1000	1000	1000	1200	1200	1200
ERV Defrost	50	50	50	50	50	50
ERV OA Filters						
Standard 2 in. MERV 14	70	70	70	80	80	80
	100	100	100	115	115	115
ERV Base Cassette	2425	2425	2425	2725	2725	2725
Supply/PE/Return Motor Includes VFD - 460 Volt ODP						
5 Hp	162	na	na	na	na	na
7.5 Hp	183	183	183	183	183	183
10 Hp	209	209	209	209	209	209
15 Hp	320	320	320	320	320	320
20 Hp	374	374	374	374	374	374
25 Hp	417	417	417	417	417	417
30 Hp	456	456	456	456	456	456
40 Hp	697	697	697	697	697	697
50 Hp	784	784	784	784	784	784
60 Hp	897	897	897	897	897	897
75 Hp	1275	1275	1275	1275	1275	1275
100 Hp	1488	1488	1488	1488	1488	1488

LEGEND

- ODP** — Open Drip Proof
- TEFC** — Totally Enclosed, Fan Cooled
- VFD** — Variable Frequency Drive

NOTE: Please refer to E-CAT for selection.

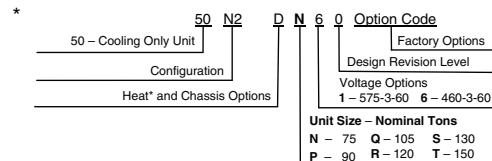

Table 2 — Operating Weights of Options and Accessories (lb) (cont)

OPTION OR ACCESSORY (for MODEL NUMBER Pos. 6)	50N UNIT SIZE (TON NOMINAL CAPACITY)*					
	N (75)	P (90)	Q (105)	R (120)	S (130)	T (150)
Supply/PE/Return Motor Includes VFD						
460 Volt TEFC						
7.5 Hp	267	267	267	267	267	267
10 Hp	283	283	283	283	283	283
15 Hp	368	368	368	368	368	368
20 Hp	437	437	437	437	437	437
25 Hp	576	576	576	576	576	576
30 Hp	604	604	604	604	604	604
40 Hp	991	991	991	991	991	991
50 Hp	925	925	925	925	925	925
60 Hp	1163	1163	1163	1163	1163	1163
75 Hp	1275	1275	1275	1275	1275	1275
100 Hp	1488	1488	1488	1488	1488	1488
Supply/PE/Return Motor Includes VFD						
575 Volt ODP						
7.5 Hp	186	186	186	186	186	186
10 Hp	204	204	204	204	204	204
15 Hp	327	327	327	327	327	327
20 Hp	369	369	369	369	369	369
25 Hp	433	433	433	433	433	433
30 Hp	456	456	456	456	456	456
40 Hp	697	697	697	697	697	697
50 Hp	784	784	784	784	784	784
60 Hp	897	897	897	897	897	897
75 Hp	1194	1194	1194	1194	1194	1194
100 Hp	1488	1488	1488	1488	1488	1488
Supply/PE/Return Motor Includes VFD						
575 Volt TEFC						
7.5 Hp	228	228	228	228	228	228
10 Hp	277	277	277	277	277	277
15 Hp	382	382	382	382	382	382
20 Hp	436	436	436	436	436	436
25 Hp	616	616	616	616	616	616
30 Hp	652	652	652	652	652	652
40 Hp	795	795	795	795	795	795
50 Hp	897	897	897	897	897	897
60 Hp	933	933	933	933	933	933
75 Hp	1194	1194	1194	1194	1194	1194
100 Hp	1488	1488	1488	1488	1488	1488
Supply/PE/Return Motor Includes VFD Bypass						
7.5 Hp	10	10	10	10	10	10
10 Hp	10	10	10	10	10	10
15 Hp	10	10	10	10	10	10
20 Hp	20	20	20	20	20	20
25 Hp	20	20	20	20	20	20
30 Hp	40	40	40	40	40	40
40 Hp	40	40	40	40	40	40
50 Hp	40	40	40	40	40	40
60 Hp	40	40	40	40	40	40
75 Hp	60	60	60	60	60	60
100 Hp	75	75	75	75	75	75
Condenser Grilles						
Standard Efficiency	100	100	100	100	125	125
High Efficiency	100	125	125	125	125	NA
Condenser Louvers						
Standard Efficiency	225	225	225	225	290	290
High Efficiency	225	290	290	290	290	NA
Service Valves and Replacable Core Filter Drier	40	45	45	50	50	50
Low Ambient	50	50	50	50	50	50
UV Lights	100	100	100	130	130	130
Marine Lights	75	75	75	75	75	75
Split - 2 piece unit	268	268	268	280	280	280

LEGEND

- ODP** — Open Drip Proof
- TEFC** — Totally Enclosed, Fan Cooled
- VFD** — Variable Frequency Drive

NOTE: Please refer to E-CAT for selection.

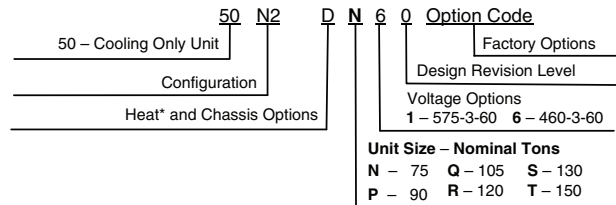

Table 3 — Units with Discharge Plenum Supply Fan and Drive Data

FAN	MOTOR HP	MOTOR RPM	MOTOR SHAFT SIZE (in.)	FAN RPM	FAN SHAFT SIZE (in.)	DRIVE SHEAVE BROWNING	BUSHING TYPE	DRIVEN SHEAVE BROWNING	BUSHING TYPE	BELTS	QTY OF BELTS	FAN SPEED (rpm)
Standard Fan 75-105 Tons Nominal Capacity	50	1770	2.125	1800	2.25	4B5V70	B 2 1/8	4B5V68	B 2 1/4	5VX530	4	1821/1821
	40	1770	2.125	1600		3B5V68	B 2 1/8	3B5V74	B 2 1/4	5VX540	3	1628/1628
	30	1765	1.875	1450		3B5V70	B 1 7/8	3B5V86	B 2 1/4	BX55	3	1448/1448
	25	1765	1.875	1400		3B5V64	B 1 7/8	3B5V80	B 2 1/4	BX53	3	1425/1425
	20	1765	1.625	1250		3B5V56	B 1 5/8	3B5V80	B 2 1/4	BX53	3	1255/1255
Standard Fan 120-150 Tons Nominal Capacity	60	1775	2.375	1550	2.5	4B5V70	B 2 3/8	4R5V80	R1 2 1/2	5VX600	4	1595/1595
	50	1770	2.125	1400		4B5V70	B 2 1/8	4R5V90	R1 2 1/2	5VX630	4	1412/1412
	40	1770	2.125	1300		3B5V68	B 2 1/8	3R5V92	R1 2 1/2	5VX630	3	1328/1328
	30	1765	1.875	1200		3B5V70	B 1 7/8	3R5V103	R1 2 1/2	5VX670	3	1229/1229
	25	1765	1.875	1100		3B5V64	B 1 7/8	3R5V103	R1 2 1/2	5VX660	3	1125/1125
High Static 75-150 Tons Nominal Capacity	100	1775	2.875	1250	3	5R5V90	R1 2 7/8	5B5V124	R1 3	5VX830	5	1264/1264
	75	1775	2.375	1100		4B5V80	B 2 3/8	4R5V132	R1 3	5VX840	4	1098/1098
	60	1775	2.375	1050		4B5V70	B 2 3/8	4R5V118	R1 3	5VX800	4	1077/1077
	50	1770	2.125	1000		4B5V70	B 2 1/8	4R5V125	R1 3	5VX830	4	1013/1013
	40	1770	2.125	900		3B5V68	B 2 1/8	3R5V140	R1 3	5VX850	3	918/918
	30	1765	1.875	800		3B5V70	B 1 7/8	3B154R	R1 3	BX88	3	821/821
	25	1765	1.875	750		3B5V64	B 1 7/8	3B154R	R1 3	BX87	3	753/753

Table 4 — Units without Plenum Supply Fan and Drive Data

FAN	MOTOR HP	MOTOR RPM	MOTOR SHAFT SIZE (in.)	FAN SHAFT SIZE (in.)	DRIVE SHEAVE BROWNING	BUSHING TYPE	DRIVEN SHEAVE BROWNING	BUSHING TYPE	BELTS	QTY OF BELTS	FAN SPEED (rpm)
ADA 800	60	1775	2.375	2.5	3B5V94	B 2 3/8	3R5V109	R1 2 1/2	5VX540	3	1561/1561
	50	1770	2.125		3B5V86	B 2 1/8	3R5V109	R1 2 1/2	5VX530	3	1426/1426
	40	1770	2.125		3B5V80	B 2 1/8	3R5V109	R1 2 1/2	5VX510	3	1328/1328
	30	1765	1.875		2B5V80	B 1 7/8	2Q5V118	Q1 2 1/2	5VX530	2	1222/1222
	25	1765	1.875		2B5V68	B 1 7/8	2Q5V109	Q1 2 1/2	5VX490	2	1128/1128
ADA 710	50	1770	2.125	2.25	2B5V110	B 2 1/8	2B5V110	B 2 1/4	5VX590	2	1770/1770
	40	1770	2.125		2B5V110	B 2 1/8	2B5V124	B 2 1/4	5VX630	2	1572/1572
	30	1765	1.875		2B5V110	B 1 7/8	2B5V136	B 2 1/4	BX64	2	1435/1435
	25	1765	1.875		1B5V110	B 1 7/8	1B5V136	B 2 1/4	5VX660	1	1430/1430
	20	1765	1.625		1B5V94	B 1 5/8	1B5V136	B 2 1/4	5VX630	1	1224/1224

Table 5 — Power Exhaust Fan and Drive Data

FAN	MOTOR HP	MOTOR RPM	MOTOR SHAFT SIZE (in.)	FAN RPM	FAN SHAFT SIZE (in.)	DRIVE SHEAVE BROWNING	BUSHING TYPE	DRIVEN SHEAVE BROWNING	BUSHING TYPE	BELTS	QTY OF BELTS	FAN SPEED (rpm)
Standard Fan 75 Tons Nominal Capacity	30	1765	1.875	1200	1.75	3B5V70	B 1 7/8	3R5V103	R1 1 3/4	5VX570	3	1229/1229
	25	1765	1.875	1150		3B5V64	B 1 7/8	3R5V103	R1 1 3/4	5VX560	3	1125/1125
	20	1765	1.625	1125		3B5V56	B 1 5/8	3B5V90	B 1 3/4	BX52	3	1120/1120
	15	1770	1.625	1100		2B5V64	B 1 5/8	2Q5V103	Q1 1 3/4	5VX580	2	1128/1128
	10	1755	1.375	1100		2BK52H	H 1 3/8	2B5V74	B 1 3/4	BX51	2	1117/1117
	7.5	1760	1.375	1100		2BK52H	H 1 3/8	2B5V74	B 1 3/4	BX51	2	1120/1120
	50	1770	2.125	1200		1.75	4B5V70	B 2 1/8	4R5V103	R1 1 3/4	5VX540	4
40	1770	2.125	1175	3B5V68	B 2 1/8		3R5V103	R1 1 3/4	5VX540	3	1197/1197	
30	1765	1.875	1150	3B5V70	B 1 7/8		3B5V110	B 1 3/4	5VX580	3	1129/1129	
25	1765	1.875	1125	3B5V64	B 1 7/8		3R5V103	R1 1 3/4	5VX550	3	1125/1125	
20	1765	1.625	1100	3B5V56	B 1 5/8		3B5V90	B 1 3/4	BX52	3	1120/1120	
15	1770	1.625	1050	2B5V64	B 1 5/8		2B5V110	B 1 3/4	5VX590	2	1036/1036	
10	1755	1.375	1000	2BK52H	H 1 3/8		2B5V80	B 1 3/4	BX51	2	1036/1036	
High Static 75-90 Tons Nominal Capacity	7.5	1760	1.375	950	2.5	2BK52H	H 1 3/8	2B5V90	B 1 3/4	BX53	2	927/927
	40	1770	2.125	650		3B5V68	B 2 1/8	35V1870E	E 2 1/2	5VX830	3	657/657
	30	1765	1.875	625		3B5V70	B 1 7/8	3TB200	Q1 2 1/2	BX86	3	635/635
	25	1765	1.875	600		3B5V64	B 1 7/8	3TB200	Q1 2 1/2	BX85	3	583/583
	20	1765	1.625	550		3B5V56	B 1 5/8	3TB184	Q1 2 1/2	BX82	3	557/557
	15	1770	1.625	500		2B5V64	B 1 5/8	25V2360E	E 2 1/2	5VX950	2	490/490
	10	1755	1.375	450		2BK52H	H 1 3/8	2TB184	Q1 2 1/2	BX82	2	460/460
High Static 105-150 Tons Nominal Capacity	7.5	1760	1.375	425	3	2BK52H	H 1 3/8	2TB184	Q1 2 1/2	AX81	2	425/425
	60	1775	2.375	600		4B5V70	B 2 3/8	4R5V212	R1 3	5VX930	4	597/597
	50	1770	2.125	575		4B5V70	B 2 1/8	4R5V212	R1 3	5VX950	4	596/596
	40	1770	2.125	550		3B5V68	B 2 1/8	3R5V212	R1 3	5VX930	3	579/579
	30	1765	1.875	525		3B5V70	B 1 7/8	3B250R	R1 3	BX103	3	509/509
	25	1765	1.875	500		3B5V64	B 1 7/8	35V2360E	E 3	5VX1000	3	488/488
	20	1765	1.625	450		3B5V56	B 1 5/8	35V2360E	E 3	5VX1000	3	428/428
15	1770	1.625	400	2B5V64	B 1 5/8	2B300R	R1 3	BX112	2	391/391		

Table 6 — ERV Drive Selection

FAN	MOTOR HP	MOTOR RPM	MOTOR SHAFT SIZE (INCHES)	FAN RPM	FAN SHAFT SIZE	DRIVE SHEAVE BROWNING	DRIVE BUSHING TYPE	DRIVEN SHEAVE BROWNING	DRIVEN BUSHING TYPE	BELTS	# OF BELTS	FAN SPEED
75-105 T Low CFM	5	1770	1.125	550	1.6875	BK45 1-1/8	na	1B5V136	B 1-11/16	BX84	1	535
	7.5	1760	1.375	600		2BK50 1-3/8	na	2B5V124	B 1-11/16	AX84	2	606
	10	1755	1.375	620		2B5V42	P1 1-3/8	2B5V124	B 1-11/16	BX84	2	622
	15	1770	1.625	750		1B5V64	B 1-5/8	1B5V124	B 1-11/16	5VX1000	1	742
120-150 T Low CFM	7.5	1760	1.375	575	1.6875	2BK45 1-3/8	na	2B5V124	B 1-11/16	BX84	2	582
	10	1755	1.375	640		2BK50 1-3/8	na	2B5V124	B 1-11/16	BX84	2	649
	15	1770	1.625	700		1B5V64	B 1-5/8	1B5V160	B 1-11/16	5VX1000	1	715
	20	1765	1.625	750		2B5V56	B 1-5/8	2B5V136	B 1-11/16	5VX930	2	734
75-105 T High CFM	10	1755	1.375	700	2.4375	1B5V50	B 1-3/8	1B5V124	B 2 7/16	5VX880	1	716
	15	1770	1.625	730		1B5V64	B 1-5/8	1B5V154	B 2 7/16	5VX1000	1	742
	20	1765	1.625	780		2B5V54	B 1-5/8	2B5V124	B 2 7/16	5VX900	2	777
	25	1765	1.875	820		2B5V56	B 1-7/8	2B5V124	B 2 7/16	5VX930	2	805
	30	1765	1.875	900		2B5V64	B 1-7/8	2B5V124	B 2 7/16	5VX930	2	918
	40 *	1770	2.125	980		3B5V60	B 2-1/8	3B5V110	B 2 7/16	5VX930	3	973
120-150 T High CFM	20	1765	1.625	650	2.4375	2B5V50	B 1-5/8	2B5V136	B 2-7/16	5VX1000	2	657
	25	1765	1.875	700		2B5V60	B 1-7/8	2B5V154	B 2 7/16	5VX1030	2	695
	30	1765	1.875	730		2B5V64	B 1-7/8	2B5V154	B 2 7/16	5VX1030	2	740
	40	1770	2.125	800		3B5V62	B 2-1/8	3B5V136	B 2 7/16	5VX1030	3	788
	50 *	1775	2.125	880		3B5V68	B 2-1/8	3B5V136	B 2 7/16	5VX1060	3	868

Table 7 — Refrigerant Charge

UNIT SIZE (NOMINAL CAPACITY, TONS)	UNIT CONFIGURATION	CHARGE (LB)		CHARGE (LB)	
		UNITS WITHOUT HUMIDI-MIZER® SYSTEM		UNITS WITH HUMIDI-MIZER® SYSTEM	
		Circuit A	Circuit B	Circuit A	Circuit B
N (75)	Standard Capacity Standard Efficiency	46.5	52.6	46.5	69.6
	High Capacity Standard Efficiency	62.9	69.0	62.9	86.0
	Standard Capacity High Efficiency	50.2	56.5	50.2	73.5
	High Capacity High Efficiency	67.0	73.5	67.0	90.5
P (90)	Standard Capacity Standard Efficiency	55.4	52.0	55.4	71.5
	High Capacity Standard Efficiency	67.8	68.5	67.8	88.3
	Standard Capacity High Efficiency	59.0	57.2	59.0	76.7
	High Capacity High Efficiency	73.8	73.8	73.8	94.0
Q (105)	Standard Capacity Standard Efficiency	71.5	67.9	71.5	87.4
	High Capacity Standard Efficiency	89.5	81.9	89.5	101.4
	Standard Capacity High Efficiency	77.5	72.9	77.5	92.4
	High Capacity High Efficiency	91.6	88.2	91.6	107.7
R (120)	Standard Capacity Standard Efficiency	59.9	57.1	59.9	76.6
	High Capacity Standard Efficiency	80.3	77.1	80.3	96.6
	Standard Capacity High Efficiency	66.5	63.3	66.5	82.8
	High Capacity High Efficiency	87.1	83.3	87.1	102.8
S (130)	Standard Capacity Standard Efficiency	84.9	81.2	84.9	100.7
	High Capacity Standard Efficiency	106.0	99.5	106.0	119.0
	Standard Capacity High Efficiency	84.5	80.7	84.5	100.2
	High Capacity High Efficiency	105.5	99.0	105.5	118.5
T (150)	Standard Capacity Standard Efficiency	82.5	82.0	82.5	101.5
	High Capacity Standard Efficiency	103.5	101.2	103.5	121.7

- NOTES:
1. ROOF CURB ACCESSORY CRFFCURB30A00-345A00 ARE SHIPPED DISASSEMBLED.
 2. ROOF CURB: 14 GA. STL.
 3. DIMENSIONS IN [] ARE MILLIMETERS.
 4. CROSS SUPPORTS EQUALLY SPACED APPROX 5'-6" APART

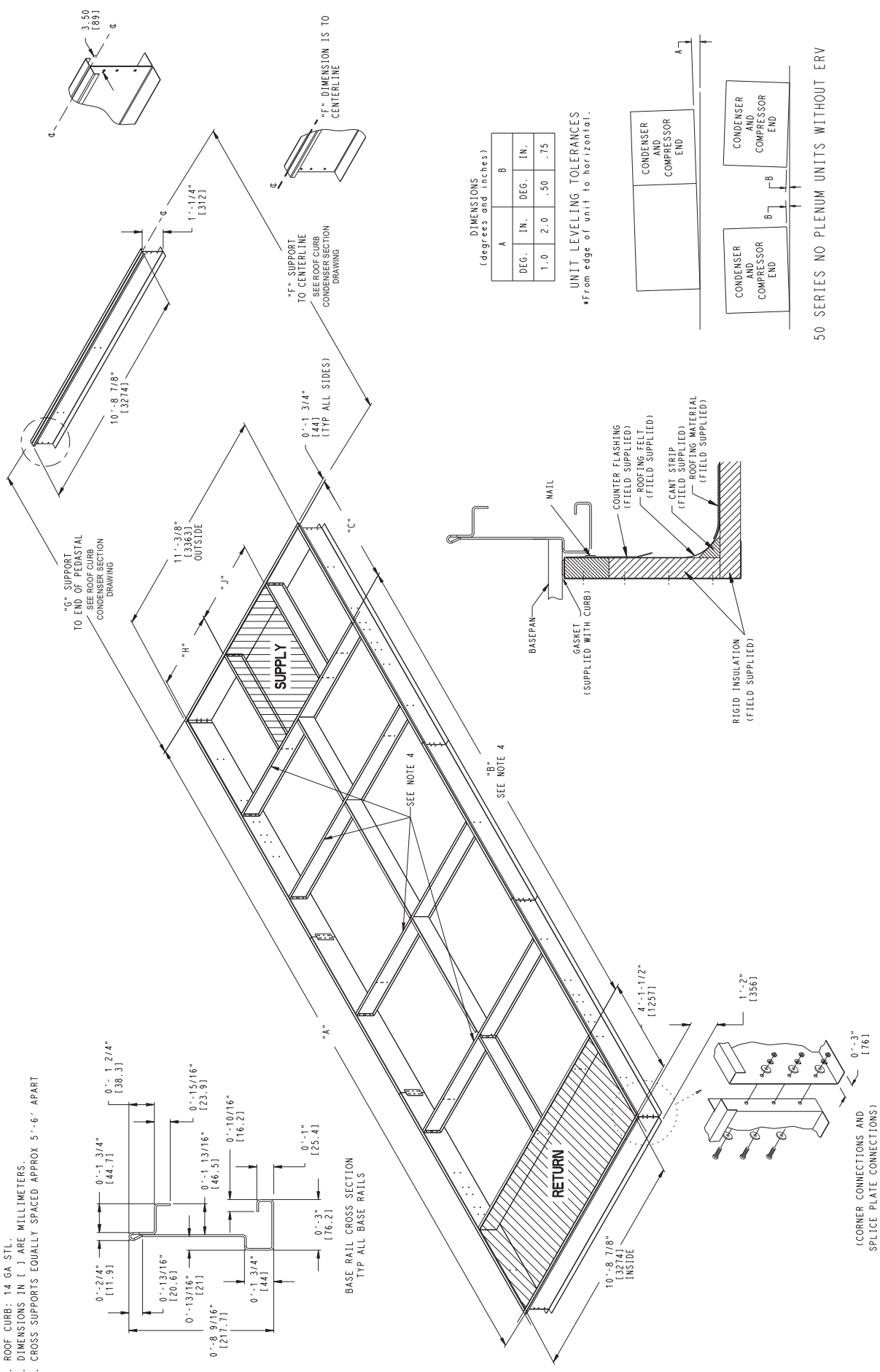

DIMENSIONS (degrees and inches)

A	B
DEG.	IN.
1.0	2.0 .50 .75

UNIT LEVELING TOLERANCES
 *From edge of unit to horizontal.

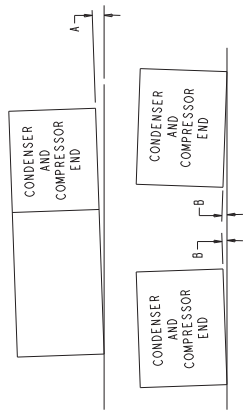

50 SERIES NO PLENUM UNITS WITHOUT ERV

Fig. 4 — 75-150 Ton 50N Roof Curb: Units without Plenum, without ERV

50N 75-105 TON ROOF CURB — No Plenum, No ERV									
PART NUMBER	SUPPLY FAN SIZE	FIELD USE FILTER	SPLIT	EXTENDED CHASSIS	DIM "A" (in.)	DIM "B" (in.)	DIM "C" (in.)	DIM "H" (in.)	DIM "J" (in.)
CRRFCURB330A00	LOW 28	No	No	No	252.65	158.46	41.20	54.24	36.25
CRRFCURB331A00	HI 40	No	No	No	273.74	163.20	57.54	46.35	52.04
CRRFCURB332A00	LOW 28	No	No	Yes	276.65	182.46	41.20	54.24	36.25
CRRFCURB333A00	HI 40	No	No	Yes	297.74	187.20	57.54	46.35	52.04
CRRFCURB334A00	LOW 28	Yes	No	No	313.15	218.96	41.20	54.24	36.25
CRRFCURB335A00	HI 40	Yes	No	No	333.72	223.70	57.54	46.35	52.04
CRRFCURB336A00	LOW 28	Yes	No	Yes	337.15	242.96	41.20	54.24	36.25
CRRFCURB337A00	HI 40	Yes	No	Yes	358.24	247.70	57.54	46.35	52.04

50N 120-150 TON ROOF CURB — No Plenum, No ERV									
PART NUMBER	SUPPLY FAN SIZE	FIELD USE FILTER	SPLIT	EXTENDED CHASSIS	DIM "A" (in.)	DIM "B" (in.)	DIM "C" (in.)	DIM "H" (in.)	DIM "J" (in.)
CRRFCURB338A00	LOW 32	No	No	No	283.58	180.56	50.05	51.75	41.25
CRRFCURB339A00	HI 40	No	No	No	283.58	173.05	57.54	46.35	52.04
CRRFCURB340A00	LOW 32	No	No	Yes	307.58	204.56	50.05	51.75	41.25
CRRFCURB341A00	HI 40	No	No	Yes	307.58	197.05	57.54	46.35	52.04
CRRFCURB342A00	LOW 32	Yes	No	No	344.08	241.06	50.05	51.75	41.25
CRRFCURB343A00	HI 40	Yes	No	No	344.08	233.55	57.54	46.35	52.04
CRRFCURB344A00	LOW 32	Yes	No	Yes	368.08	265.06	50.05	51.75	41.25
CRRFCURB345A00	HI 40	Yes	No	Yes	368.08	257.55	57.54	46.35	52.04

Fig. 4 — 75-150 Ton 50N Roof Curb: Units without Plenum, without ERV (cont)

- NOTES:
1. ROOF CURB ACCESSORY CRRCURB201A00-285A00 ARE SHIPPED DISASSEMBLED.
 2. ROOF CURB: 14 GA. (VA03-56) STL.
 3. DIMENSIONS IN () ARE MILLIMETERS.
 4. CROSS SUPPORTS EQUALLY SPACED APPROX 5'-6" APART

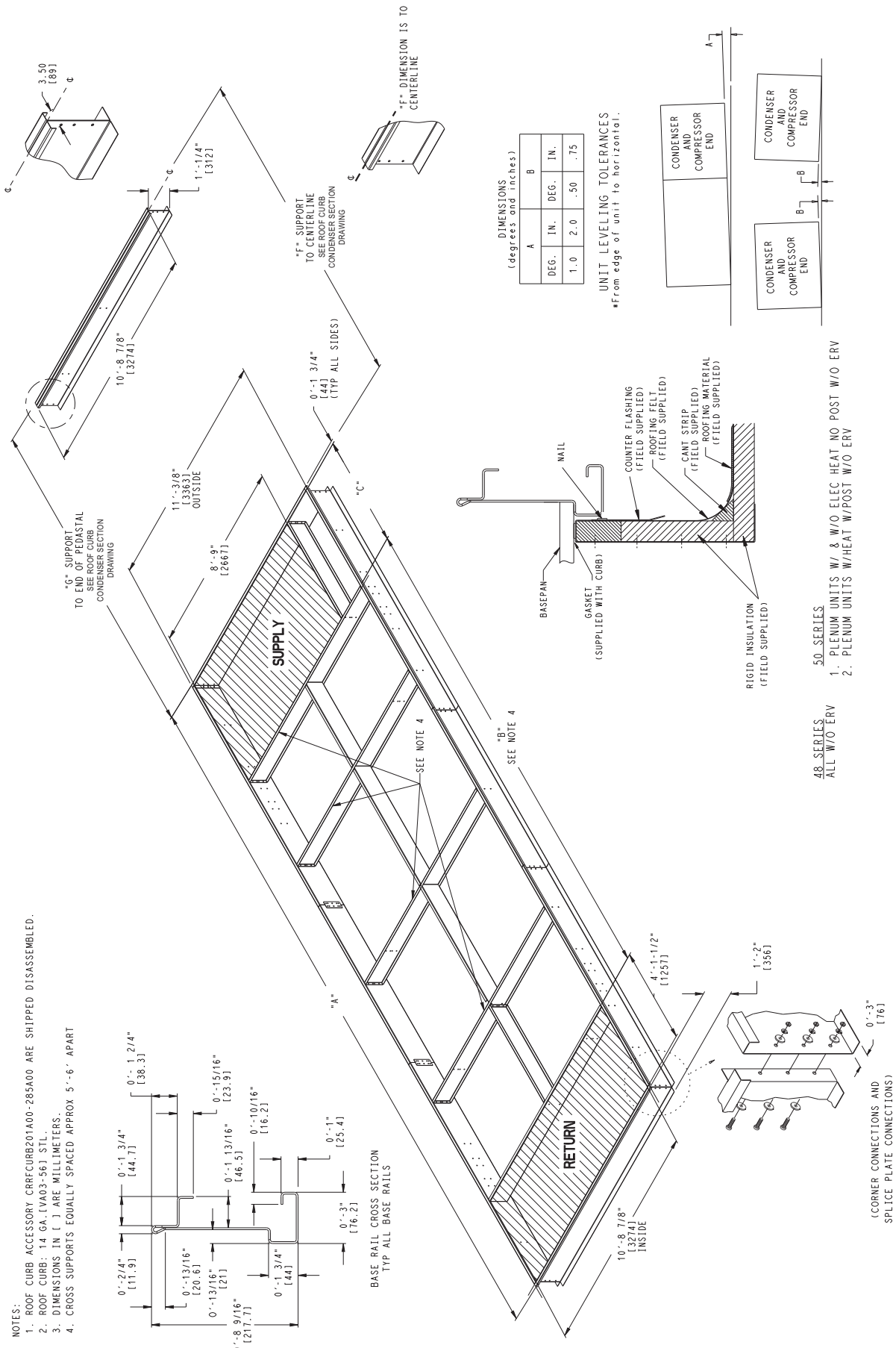

DIMENSIONS (degrees and inches)

A	B
DEG.	IN.
1.0	2.0
	.50
	.75

UNIT LEVELING TOLERANCES
*From edge of unit to horizontal.

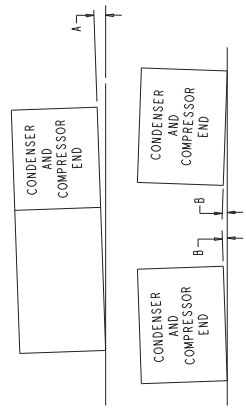

50. SERIES
1. PLENUM UNITS W/ & W/O ELEC HEAT NO POST W/O ERV
2. PLENUM UNITS W/HEAT W/POST W/O ERV
48. SERIES
ALL W/O ERV

(CORNER CONNECTIONS AND SPLICE PLATE CONNECTIONS)

Fig. 5 — 75-150 Ton 48/50N Roof Curb: Units with Plenum, with Electric Heat, with Extra Sections, without ERV; Units with Plenum, with and without Electric Heat, without Extra Sections, without ERV

50N 75-105 TON ROOF CURB — WITH PLENUM, NO ERV								
PART NUMBER	SUPPLY FAN SIZE	FIELD USE FILTER	EXTRA SECT.	SPLIT	EXTENDED CHASSIS	DIM "A" (in.)	DIM "B" (in.)	DIM "C" (in.)
CRRFCURB201A00	LOW 28	No	None	No	No	296.11	193.61	49.50
CRRFCURB202A00	HI 40	No	None	No	No	311.20	208.70	49.50
CRRFCURB203A00	LOW 28	No	None	No	Yes	320.11	217.61	49.50
CRRFCURB204A00	HI 40	No	None	No	Yes	335.20	232.70	49.50
CRRFCURB205A00	LOW 28	No	None	No	No	356.61	254.11	49.50
CRRFCURB206A00	HI 40	Yes	None	No	No	371.70	269.20	49.50
CRRFCURB207A00	LOW 28	Yes	None	No	Yes	380.61	278.11	49.50
CRRFCURB208A00	HI 40	Yes	None	No	Yes	395.70	293.20	49.50
CRRFCURB209A00	LOW 28	Yes	4 ft	Yes	No	419.36	316.86	49.50
CRRFCURB210A00	HI 40	No	4 ft	Yes	No	434.45	331.95	49.50
CRRFCURB211A00	LOW 28	No	4 ft	Yes	Yes	443.36	340.86	49.50
CRRFCURB212A00	HI 40	No	4 ft	Yes	Yes	485.45	382.95	49.50
CRRFCURB213A00	LOW 28	No	8 ft	Yes	No	467.61	365.11	49.50
CRRFCURB214A00	LOW 28	Yes	4 ft	Yes	No	479.86	377.36	49.50
CRRFCURB215A00	HI 40	No	8 ft	Yes	No	482.70	380.20	49.50
CRRFCURB216A00	LOW 28	No	8 ft	Yes	Yes	491.61	389.11	49.50
CRRFCURB217A00	HI 40	Yes	4 ft	Yes	No	494.95	392.45	49.50
CRRFCURB218A00	LOW 28	Yes	4 ft	Yes	Yes	503.86	401.36	49.50
CRRFCURB219A00	HI 40	No	8 ft	Yes	Yes	506.70	404.20	49.50
CRRFCURB220A00	HI 40	Yes	4 ft	Yes	Yes	518.95	416.45	49.50
CRRFCURB221A00	LOW 28	Yes	8 ft	Yes	No	528.11	425.61	49.50
CRRFCURB222A00	HI 40	Yes	8 ft	Yes	No	543.20	440.70	49.50
CRRFCURB223A00	LOW 28	Yes	8 ft	Yes	Yes	552.11	449.61	49.50
CRRFCURB224A00	HI 40	Yes	8 ft	Yes	Yes	567.20	464.70	49.50

50N 120-150 TON ROOF CURB — WITH PLENUM, NO ERV								
PART NUMBER	FIELD USE FILTER	EXTRA SECT.	SPLIT	EXTENDED CHASSIS	DIM "A" (in.)	DIM "B" (in.)	DIM "C" (in.)	DIM "C" (in.)
CRRFCURB249A00	No	None	No	No	321.04	218.54	49.50	
CRRFCURB250A00	No	None	No	Yes	345.04	242.54	49.50	
CRRFCURB251A00	Yes	None	No	No	381.54	279.04	49.50	
CRRFCURB252A00	Yes	None	No	Yes	405.54	303.04	49.50	
CRRFCURB253A00	No	4 ft	Yes	No	444.29	331.79	49.50	
CRRFCURB254A00	No	4 ft	Yes	Yes	466.29	365.79	49.50	
CRRFCURB255A00	Yes	4 ft	Yes	No	492.54	390.04	49.50	
CRRFCURB256A00	Yes	4 ft	Yes	No	504.79	402.29	49.50	
CRRFCURB257A00	No	8 ft	Yes	Yes	516.54	414.04	49.50	
CRRFCURB258A00	No	8 ft	Yes	Yes	528.79	426.29	49.50	
CRRFCURB259A00	Yes	8 ft	Yes	No	553.04	450.54	49.50	
CRRFCURB260A00	Yes	8 ft	Yes	Yes	577.04	474.54	49.50	

**Fig. 5 — 75-150 Ton 50N Roof Curb:
Units with Plenum, without Electric Heat, with Extra Sections, without ERV (cont)**

- NOTES:
1. ROOF CURB ACCESSORY CRRFCURB354A00-403A00 ARE SHIPPED DISASSEMBLED.
 2. ROOF CURB: 14 GA. (VA03-56) STL.
 3. DIMENSIONS IN [] ARE MILLIMETERS.
 4. CROSS SUPPORTS EQUALLY SPACED APPROX 5'-6" APART

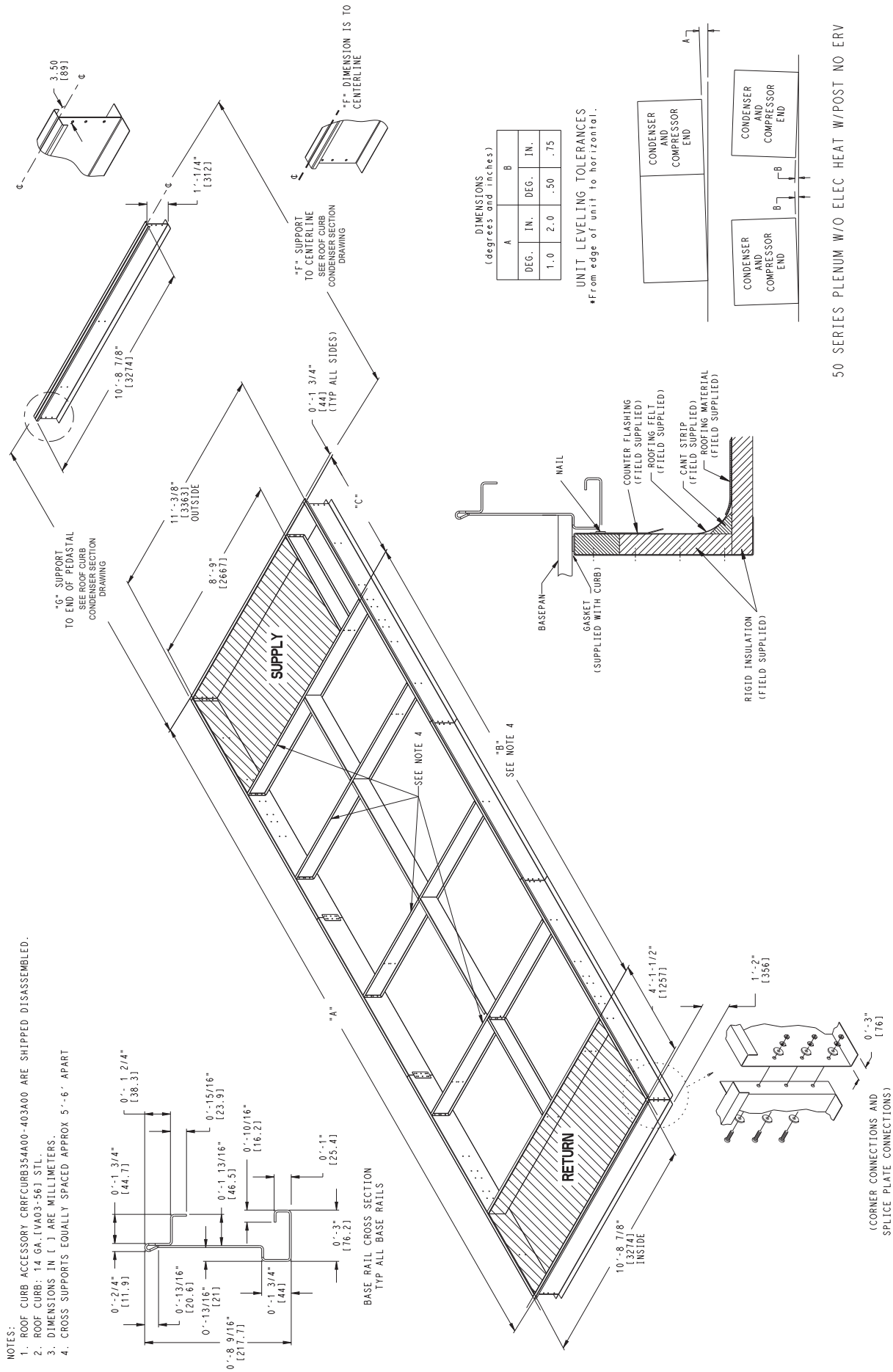

50 SERIES PLENUM W/O ELEC HEAT W/POST NO ERV

Fig. 6 — 75-150 Ton 50N Roof Curb: Units with Plenum, without Electric Heat, with Extra Sections, without ERV

50N 75-105 TON ROOF CURB — WITH PLENUM, WITH POST, W/O ELECTRIC HEAT								
PART NUMBER	SUPPLY FAN	FIELD USE FILTER	EXTRA SECT.	SPLIT	EXTENDED CHASSIS	DIM "A" (in.)	DIM "B" (in.)	DIM "C" (in.)
CRRFCURB354A00	LOW 28	No	4 ft	No	No	344.36	241.86	49.50
CRRFCURB355A00	HI 40	No	4 ft	No	No	359.45	256.95	49.50
CRRFCURB356A00	LOW 28	No	4 ft	No	Yes	368.36	365.85	49.50
CRRFCURB358A00	HI 40	No	4 ft	No	Yes	383.45	280.95	49.50
CRRFCURB360A00	LOW 28	No	8 ft	No	No	392.61	290.11	49.50
CRRFCURB362A00	HI 40	No	8 ft	No	No	407.70	305.20	49.50
CRRFCURB363A00	LOW 28	Yes	8 ft	No	Yes	434.86	332.36	49.50
CRRFCURB364A00	LOW 28	No	8 ft	No	Yes	416.61	314.11	49.50
CRRFCURB365A00	HI 40	No	8 ft	Yes	Yes	449.95	347.45	49.50
CRRFCURB366A00	LOW 28	Yes	4 ft	No	No	404.86	302.36	49.50
CRRFCURB367A00	HI 40	Yes	4 ft	Yes	No	438.20	335.70	49.50
CRRFCURB368A00	LOW 28	Yes	4 ft	Yes	Yes	447.11	344.61	49.50
CRRFCURB369A00	HI 40	Yes	4 ft	Yes	Yes	462.20	359.70	49.50
CRRFCURB370A00	LOW 28	Yes	8 ft	Yes	No	471.36	368.86	49.50
CRRFCURB371A00	HI 40	Yes	8 ft	Yes	No	486.45	383.95	49.50
CRRFCURB372A00	LOW 28	No	8 ft	Yes	Yes	495.36	392.86	49.50
CRRFCURB373A00	HI 40	Yes	8 ft	Yes	Yes	510.45	407.95	49.50
CRRFCURB396A00	HI 40	No	8 ft	No	Yes	431.70	329.20	49.50
CRRFCURB397A00	HI 40	Yes	4 ft	No	No	419.95	317.45	49.50
CRRFCURB398A00	LOW 28	Yes	4 ft	No	Yes	428.86	326.36	49.50
CRRFCURB399A00	HI 40	Yes	4 ft	No	Yes	443.95	341.45	49.50
CRRFCURB400A00	LOW 28	Yes	8 ft	No	No	453.11	350.61	49.50

50N 120-150 TON ROOF CURB — WITH PLENUM, WITH POST, W/O ELECTRIC HEAT							
PART NUMBER	FIELD USE FILTER	EXTRA SECT.	SPLIT	EXTENDED CHASSIS	DIM "A" (in.)	DIM "B" (in.)	DIM "C" (in.)
CRRFCURB374A00	No	4 ft	No	No	369.29	266.79	49.50
CRRFCURB376A00	No	4 ft	No	Yes	393.29	209.79	49.50
CRRFCURB377A00	No	8 ft	Yes	No	435.79	333.29	49.50
CRRFCURB378A00	No	8 ft	No	No	417.54	315.04	49.50
CRRFCURB379A00	No	8 ft	Yes	Yes	459.79	357.29	49.50
CRRFCURB380A00	Yes	4 ft	Yes	No	448.04	345.54	49.50
CRRFCURB381A00	Yes	4 ft	Yes	Yes	472.04	369.54	49.50
CRRFCURB382A00	Yes	8 ft	Yes	No	496.29	393.79	49.50
CRRFCURB383A00	Yes	8 ft	Yes	Yes	520.29	417.79	49.50
CRRFCURB401A00	No	8 ft	No	Yes	441.54	339.04	49.50
CRRFCURB402A00	No	4 ft	No	No	429.79	327.29	49.50
CRRFCURB403A00	No	4 ft	No	Yes	453.79	351.29	49.50

Fig. 6 — 75-150 Ton 50N Roof Curb: Units with Plenum, without Electric Heat, with Extra Sections, without ERV (cont)

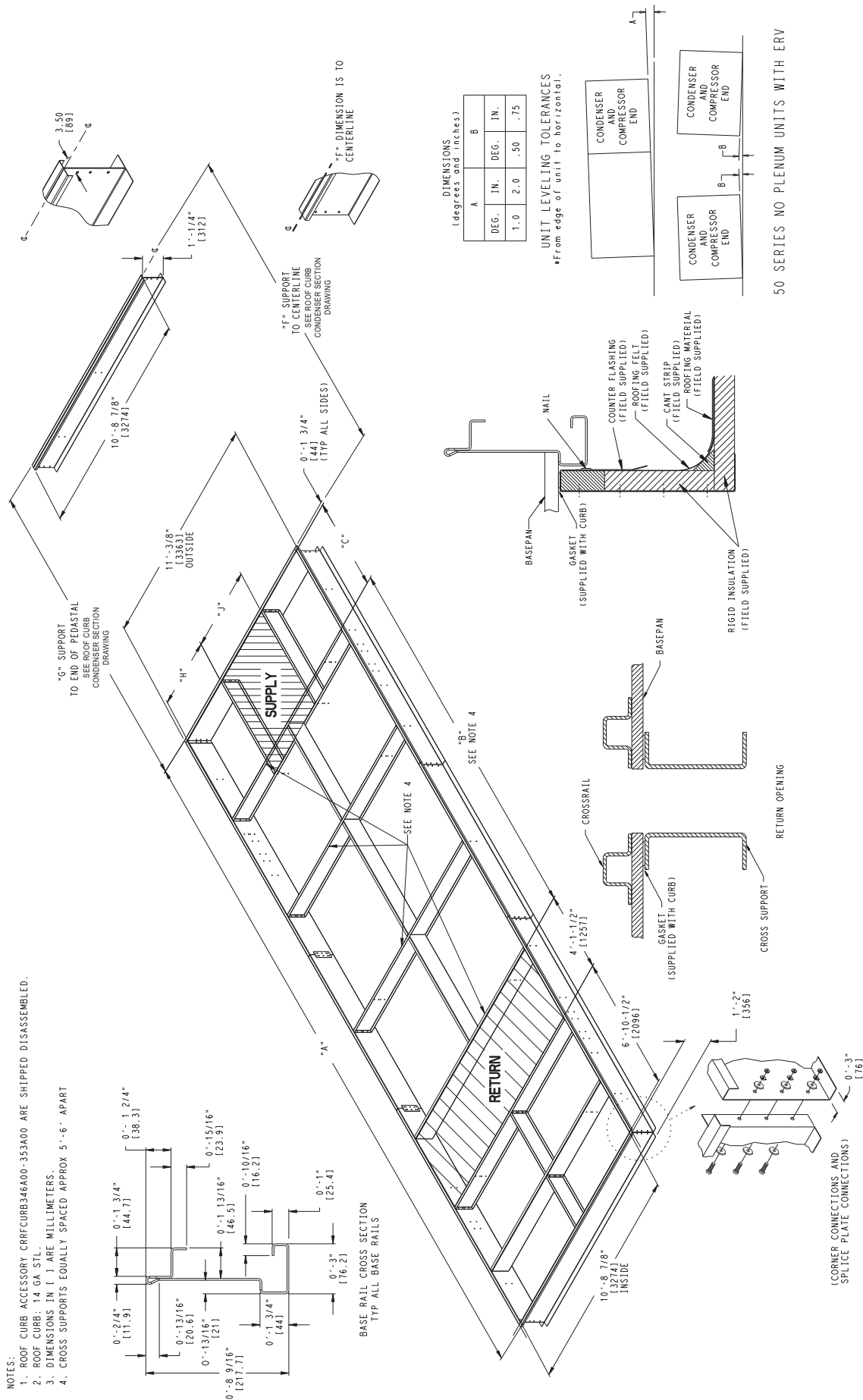
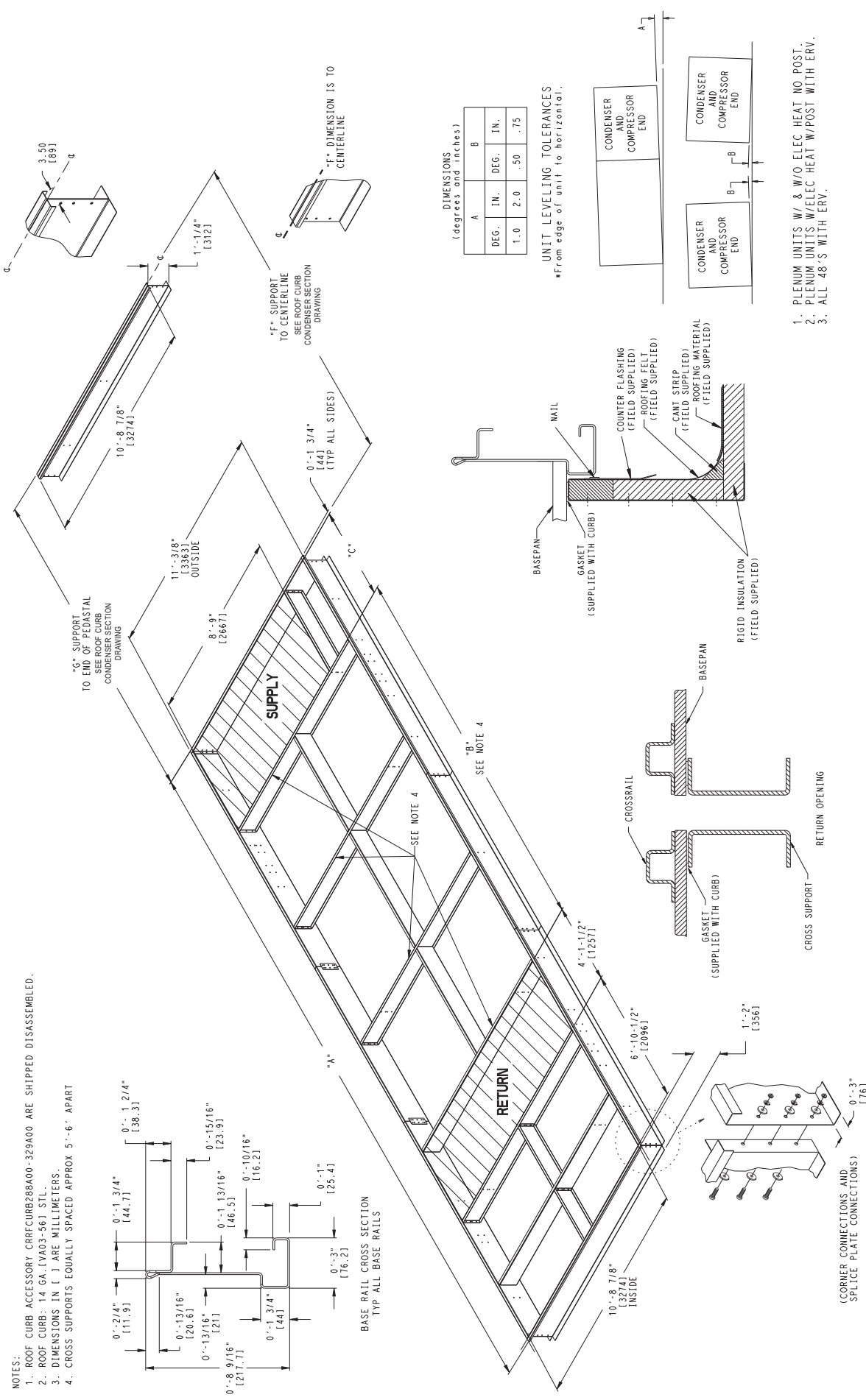

Fig. 7 — 75-150 Ton 50N Roof Curb: Units without Plenum, with ERV

50N 75-105 TON ROOF CURB — NO PLENUM, WITH ERV — POSITION 6 - N, P, Q									
PART NUMBER	SUPPLY FAN	FIELD USE FILTER	SPLIT	EXTENDED CHASSIS	DIM "A" (in.)	DIM "B" (in.)	DIM "C" (in.)	DIM "H" (in.)	DIM "J" (in.)
CRRFCURB346A00	LOW 28	No	Yes	No	322.91	146.28	41.20	52.24	36.25
CRRFCURB347A00	HI 40	No	Yes	No	344.00	451.97	57.54	46.35	52.04
CRRFCURB348A00	LOW 28	No	Yes	Yes	346.91	170.28	41.20	52.24	36.25
CRRFCURB349A00	HI 40	No	Yes	Yes	368.00	174.97	57.54	46.35	52.04

50N 120-150 TON ROOF CURB — NO PLENUM, WITH ERV — POSITION 6 - R, S, T									
PART NUMBER	SUPPLY FAN	FIELD USE FILTER	SPLIT	EXTENDED CHASSIS	DIM "A" (in.)	DIM "B" (in.)	DIM "C" (in.)	DIM "H" (in.)	DIM "J" (in.)
CRRFCURB350A00	LOW 32	No	Yes	No	353.86	168.33	50.05	51.75	41.25
CRRFCURB351A00	HI 40	No	Yes	No	353.86	160.80	57.54	46.35	52.04
CRRFCURB352A00	LOW 32	No	Yes	Yes	377.86	192.33	50.05	51.75	41.25
CRRFCURB353A00	HI 40	No	Yes	Yes	377.86	184.80	57.54	46.35	52.04

Fig. 7 — 75-150 Ton 50N Roof Curb: Units without Plenum, with ERV (cont)



- NOTES:
1. ROOF CURB ACCESSORY CRRFCURB288A00-329A00 ARE SHIPPED DISASSEMBLED.
 2. ROOF CURB: 14 GA. (VA03-56) STL.
 3. DIMENSIONS IN [] ARE MILLIMETERS.
 4. CROSS SUPPORTS EQUALLY SPACED APPROX 5'-6" APART

1. PLENUM UNITS W/ & W/O ELEC HEAT NO POST.
2. PLENUM UNITS W/ELEC HEAT W/POST WITH ERV.
3. ALL 48'S WITH ERV.

Fig. 8 — 75-150 Ton 48/50N Roof Curb: Units with Plenum, with Electric Heat, with Extra Sections, with ERV; Units with Plenum, with and without Electric Heat, without Extra Sections, with ERV

50N 75-105 TON ROOF CURB — WITH PLENUM, WITH ERV								
PART NUMBER	SUPPLY FAN	FIELD USE FILTER	EXTRA SECTION	SPLIT	EXTENDED CHASSIS	DIM "A" (in.)	DIM "B" (in.)	DIM "C" (in.)
CRRFCURB288A00	LOW 28	No	No	Yes	No	366.37	181.37	49.50
CRRFCURB289A00	HI 40	No	No	Yes	No	381.46	196.46	49.50
CRRFCURB290A00	LOW 28	No	No	Yes	Yes	390.37	205.37	49.50
CRRFCURB291A00	HI 40	No	No	Yes	Yes	405.46	220.46	49.50
CRRFCURB292A00	LOW 28	No	4 ft	Yes	No	471.37	286.37	49.50
CRRFCURB293A00	HI 40	No	4 ft	Yes	No	486.46	301.46	49.50
CRRFCURB294A00	LOW 28	No	4 ft	Yes	Yes	495.37	310.37	49.50
CRRFCURB295A00	HI 40	No	4 ft	Yes	Yes	510.46	325.46	49.50
CRRFCURB296A00	LOW 28	No	8 ft	Yes	No	519.62	334.62	49.50
CRRFCURB297A00	HI 40	No	8 ft	Yes	No	534.71	349.71	49.50
CRRFCURB298A00	LOW 28	No	8 ft	Yes	Yes	543.62	358.62	49.50
CRRFCURB299A00	HI 40	No	8 ft	Yes	Yes	558.71	373.71	49.50

50N 120-150 TON ROOF CURB — POSITION 6 - R, S, T							
PART NUMBER	FIELD USE FILTER	EXTRA SECTION	SPLIT	EXTENDED CHASSIS	DIM "A" (in.)	DIM "B" (in.)	DIM "C" (in.)
CRRFCURB312A00	No	No	Yes	No	391.30	206.30	49.50
CRRFCURB313A00	No	No	Yes	Yes	415.30	230.30	49.50
CRRFCURB314A00	No	4 ft	Yes	No	496.30	311.30	49.50
CRRFCURB315A00	No	4 ft	Yes	Yes	520.30	335.30	49.50
CRRFCURB316A00	No	8 ft	Yes	No	544.55	359.55	49.50
CRRFCURB317A00	No	8 ft	Yes	Yes	568.55	383.55	49.50

**Fig. 8 — 75-150 Ton 48/50N Roof Curb:
Units with Plenum, with Electric Heat, with Extra Sections, with ERV;
Units with Plenum, with and without Electric Heat, without Extra Sections, with ERV (cont)**

- NOTES:
1. ROOF CURB ACCESSORY CRRFCURB384A00-395A00 ARE SHIPPED DISASSEMBLED.
 2. ROOF CURB: 14 GA. [VA03-56] STL.
 3. DIMENSIONS IN [] ARE MILLIMETERS.
 4. CROSS SUPPORTS EQUALLY SPACED APPROX 5'-6" APART

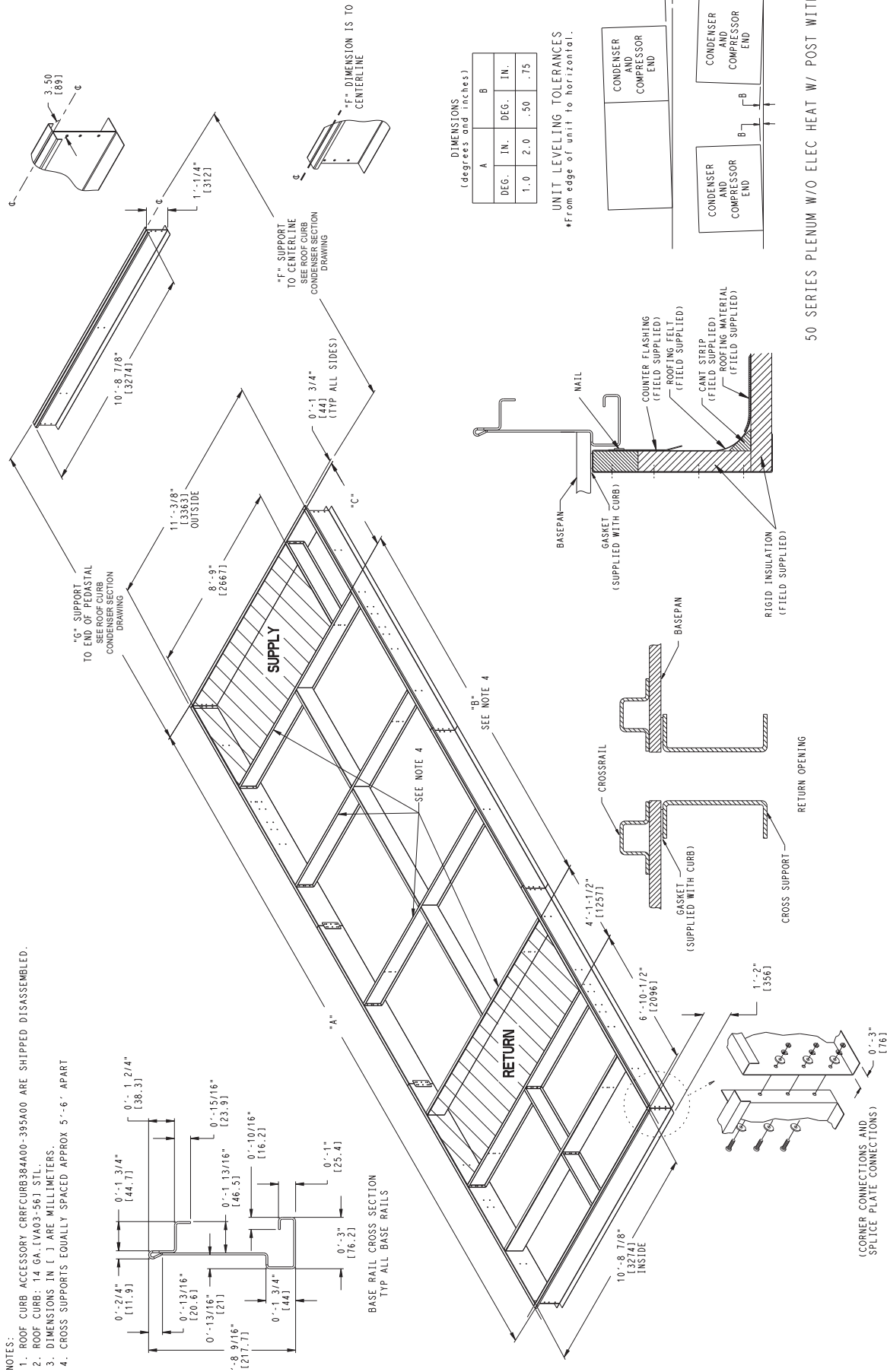

Fig. 9 — 75-150 Ton 50N Roof Curb: Units with Plenum, without Electric Heat, with Extra Section, with ERV

50N 75-105 TON ROOF CURB — PLENUM, WITH POST, WITH ERV, WITHOUT ELECTRIC HEAT								
PART NUMBER	SUPPLY FAN SIZE	FIELD USE FILTER	EXTRA SECTION	SPLIT	EXTENDED CHASSIS	DIM "A" (in.)	DIM "B" (in.)	DIM "C" (in.)
CRRFCURB384A00	LOW 28	No	4 ft	Yes	No	414.62	229.62	49.50
CRRFCURB385A00	HI 40	No	4 ft	Yes	No	429.71	244.71	49.50
CRRFCURB386A00	LOW 28	No	4 ft	Yes	Yes	438.62	253.62	49.50
CRRFCURB387A00	HI 40	No	4 ft	Yes	Yes	453.71	268.71	49.50
CRRFCURB388A00	LOW 28	No	8 ft	Yes	No	462.87	277.87	49.50
CRRFCURB389A00	HI 40	No	8 ft	Yes	No	477.96	292.96	49.50
CRRFCURB390A00	LOW 28	No	8 ft	Yes	Yes	486.87	301.87	49.50
CRRFCURB391A00	HI 40	No	8 ft	Yes	Yes	501.96	316.96	49.50

50N 120-150 TON ROOF CURB — PLENUM, WITH POST, WITH ERV, WITHOUT ELECTRIC HEAT							
PART NUMBER	FIELD USE FILTER	EXTRA SECTION	SPLIT	EXTENDED CHASSIS	DIM "A" (in.)	DIM "B" (in.)	DIM "C" (in.)
CRRFCURB392A00	No	4 ft	WITH SPLIT	No	439.55	254.55	49.50
CRRFCURB393A00	No	4 ft	WITH SPLIT	Yes	463.55	278.55	49.50
CRRFCURB394A00	No	8 ft	WITH SPLIT	No	487.80	302.80	49.50
CRRFCURB395A00	No	8 ft	WITH SPLIT	Yes	511.80	326.80	49.50

Fig. 9 — 75-150 Ton 50N Roof Curb: with Plenum, without Electric Heat, with Extra Section, With ERV (cont)

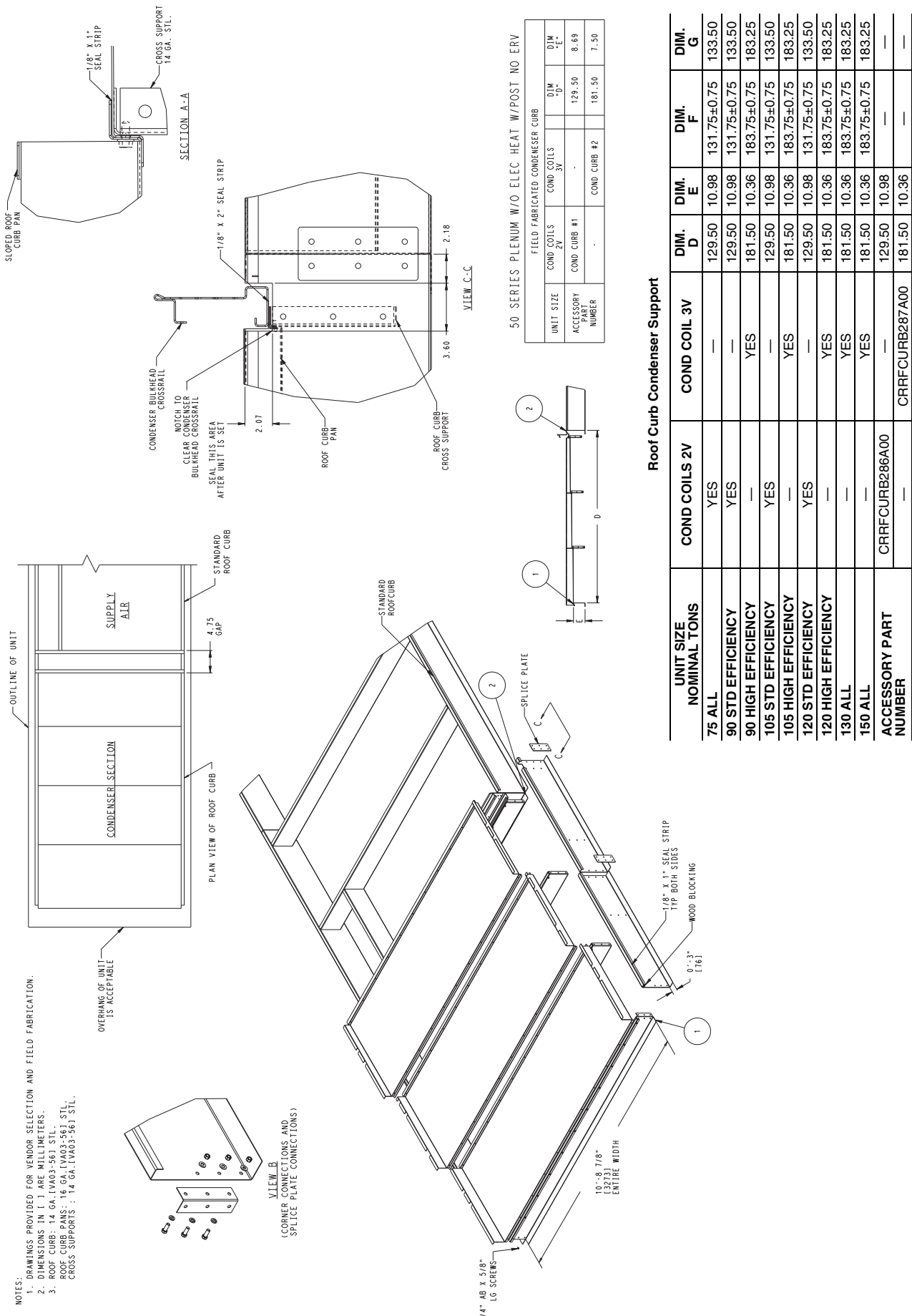

Fig. 10 — 50N Roof Curb: Condenser Section

- NOTES:
1. DIMENSIONS ARE IN INCHES.
 2. UNIT WEIGHT AND CENTER OF GRAVITY INCLUDES ECONOMIZER, LARGEST INDOOR FAN MOTOR AND HIGH CAPACITY EVAPORATOR COIL.
 3. UNIT CLEARANCES STRICTLY CONDENSER FANS
 4. ECONOMIZER END: 10'-0"
 5. SUGGESTED FIELD CONNECTIONS TO BE MADE INSIDE OR OUTSIDE OF DUCT FLANGES.
 6. WHEN UNITS SLAB MOUNTED ALLOW ADEQUATE HEIGHT FOR ECONOMIZER SIDE HOODS ARE SHIPPED INSIDE OF UNIT.
 7. PIPE CHASE LOCATIONS ARE RECOMMENDATIONS ONLY. OPENINGS ARE NOT FACTORY PROVIDED.
 8. OPERATIONAL FACTORY SUPPLIED HOT WATER AND STEAM COILS ON UNITS WITHOUT ELECTRIC HEAT.
 - HOT WATER COIL DIMENSIONS:
 - TUBE O. D.: 1 1/2" - ROWS 2 - HEIGHT: 64.50"
 - PIPE SIZE 1 1/2" NPT
 - STEAM COIL DIMENSIONS:
 - LENGTH: 110.00" - WIDTH: 5.00" - HEIGHT: 54.00"
 - TUBE O. D.: 1.00" - ROWS 2
 - PIPE SIZE 2 1/2" NPT

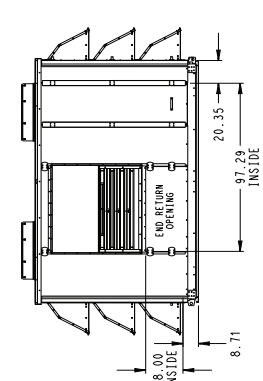
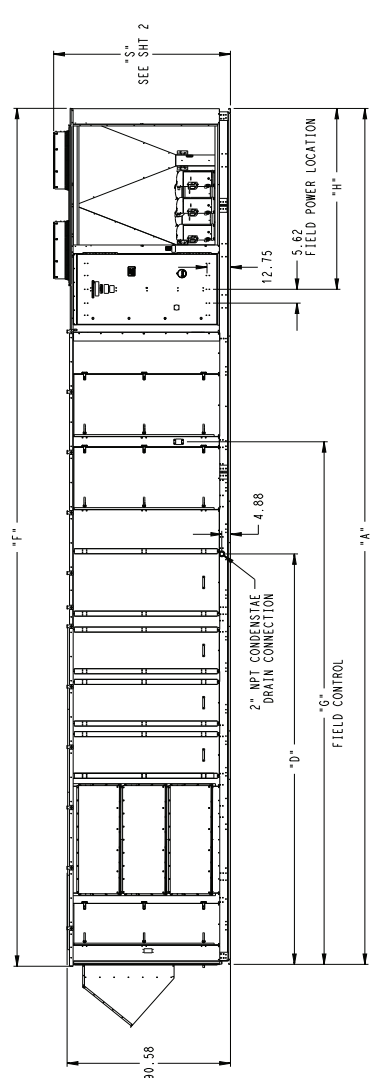
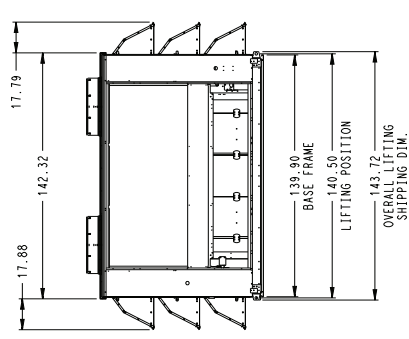
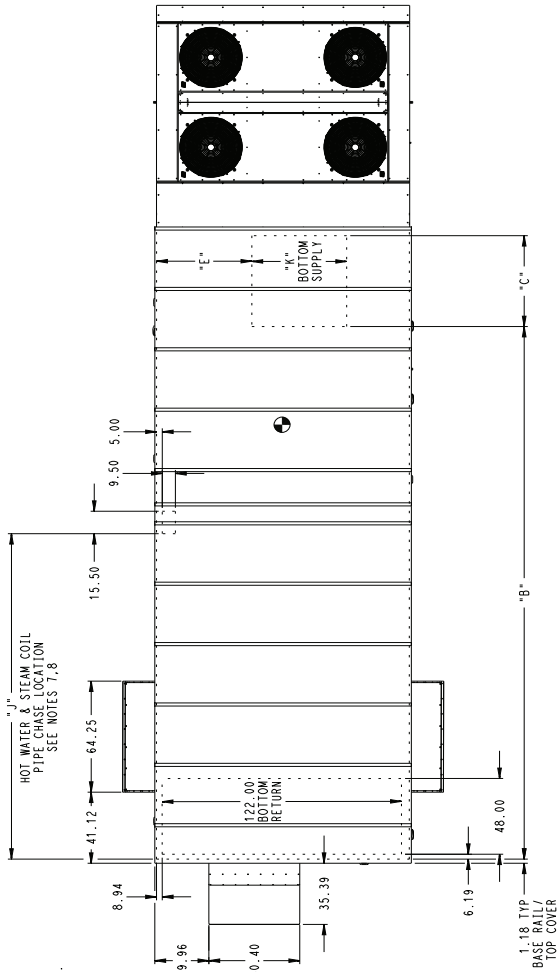

Fig. 11 — 50N Unit Sizes N, P, Q — without Plenum, without ERV (75-105 Ton Rooftop Unit)

SIZE (TON) EFF	EXTENDED CHASSIS	SUPPLY FAN TYPE	FIELD USE FILTER SECTION	BLANK SECTION	CONDENSER # OF V'S	A (in.)	B (in.)	C (in.)	D (in.)	E (in.)	F (in.)	G (in.)	H (in.)	J (in.)	K (in.)
75 ALL 90 STD EFF 105 STD EFF	No	STD	No	No	2	389.65	214.170	36.32	177.02	60.50	390.89	202.75	119.76	—	34.76
			Yes	No	2	450.15	274.670	36.32	237.52	58.00	451.39	263.25	119.76	—	34.76
		HIGH	No	No	2	410.74	218.850	49.90	177.02	52.61	411.98	217.84	119.76	—	50.54
			Yes	No	2	471.24	279.350	49.90	237.52	52.61	472.48	278.34	119.76	—	50.54
	Yes	STD	No	No	2	413.65	238.170	36.32	177.02	60.50	414.89	226.75	119.76	185.75	34.76
			Yes	No	2	474.15	298.670	36.32	237.52	58.00	475.39	287.25	119.76	246.25	34.76
		HIGH	No	No	2	434.74	242.850	49.90	177.02	52.61	435.98	241.84	119.76	185.75	50.54
			Yes	No	2	495.24	303.350	49.90	237.52	52.61	496.48	302.34	119.76	246.25	50.54
90 HI EFF 105 HI EFF	No	STD	No	No	3	441.65	214.170	36.32	177.02	60.50	442.89	202.75	171.76	—	34.76
			Yes	No	3	502.14	274.670	36.32	237.52	58.00	503.39	263.25	171.76	—	34.76
		HIGH	No	No	3	462.74	218.850	49.90	177.02	52.61	463.98	217.84	171.76	—	50.54
			Yes	No	3	523.24	279.350	49.90	237.52	52.61	524.48	278.34	171.76	—	50.54
	Yes	STD	No	No	3	465.65	238.317	36.32	177.02	60.50	466.89	226.75	171.76	185.75	34.76
			Yes	No	3	526.15	298.670	36.32	237.52	58.00	527.39	287.25	171.76	246.25	34.76
		HIGH	No	No	3	486.74	242.850	49.90	177.02	52.61	487.98	241.84	171.76	185.75	50.54
			Yes	No	3	547.24	303.350	49.90	237.52	52.61	548.48	302.34	171.76	246.25	50.54

50N 75-105 CONDENSER POSITION 6, OPTION 9 AND 10

UNIT SIZE	COND COILS 2V	COND COILS 3V	LOW SOUND 10B / 10D	DIM "S" (in.)
75 ALL	Yes	—	No	92.62
	Yes	—	Yes	98.06
90 STD EFF	Yes	—	No	92.62
	Yes	—	Yes	98.06
90 HI EFF	—	Yes	Yes	98.06
105 STD EFF	Yes	—	No	98.06
	Yes	—	Yes	98.06
105 HI EFF	—	Yes	Yes	98.06

Fig. 11 — 50N Unit Sizes N, P, Q — without Plenum, without ERV (75-105 Ton Rooftop Unit) (cont)

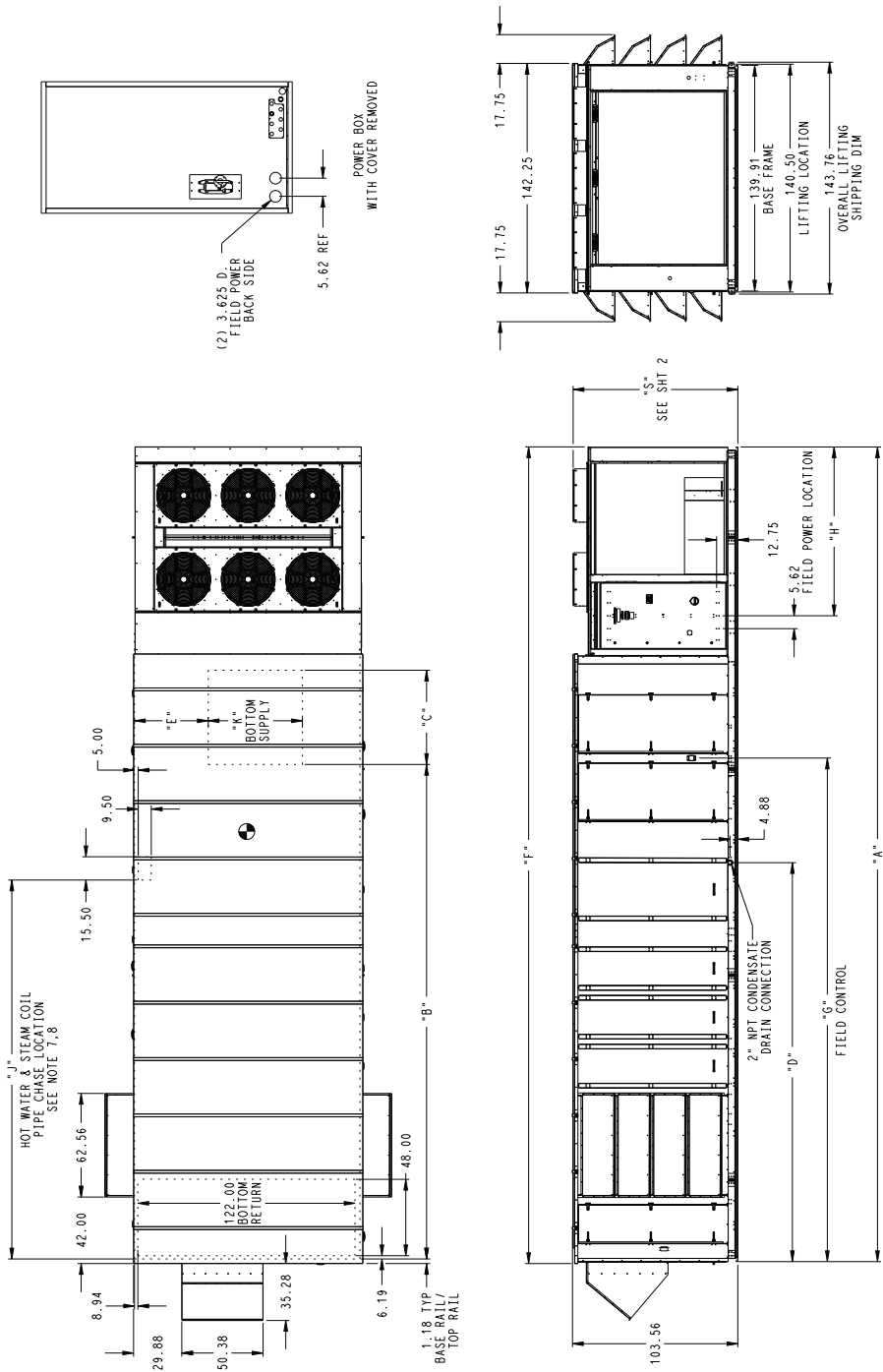

- NOTES:
1. DIMENSIONS ARE IN INCHES.
 2. UNIT WEIGHT AND CENTER OF GRAVITY INCLUDES ECONOMIZER, LARGEST INDOOR FAN MOTOR AND HIGH CAPACITY EVAPORATOR COIL.
 3. UNIT CLEARANCES:
 - TOP - DO NOT RESTRICT CONDENSER FANS
 - CONDENSER CLEARANCE: 6" END, 8" - 0"
 4. SUGGESTED FIELD CONNECTIONS TO MADE INSIDE OR OUTSIDE OF DUCT FLANGES.
 5. WHEN UNIT IS SLAB MOUNTED ALLOW ADEQUATE HEIGHT FOR CONDENSATE DRAIN TRAP.
 6. ECONOMIZER SIDE HOODS ARE SHIPPED INSIDE OF UNIT.
 7. OPERATIONAL FACTORY PREPARED RECOMMENDATIONS ONLY.
 8. OPERATIONAL FACTORY SUPPLIED HOT WATER AND STEAM COILS ON UNITS WITHOUT ELECTRIC HEAT.
 - HOT WATER COIL DIMENSIONS:
 - LENGTH: 108.75" - WIDTH: 6.00" - HEIGHT: 64.50"
 - TUBE O. D.: 1/2" - ROWS 2
 - STEAM COIL DIMENSIONS:
 - LENGTH: 110.00" - WIDTH: 5.00" - HEIGHT: 54.00"
 - TUBE O. D.: 1.00" - ROWS 2
 - PIPE SIZE 2 1/2" NPT

Fig. 12 — 50N Unit Sizes R, S, T — without Plenum, without ERV (120-150 Ton Rooftop Unit)

SIZE (TON) EFF	EXTENDED CHASSIS	SUPPLY FAN TYPE	FIELD USE FILTER SECTION	BLANK SECTION	CONDENSER # OF V'S	A (in.)	B (in.)	C (in.)	D (in.)	E (in.)	F (in.)	G (in.)	H (in.)	J (in.)	K (in.)
120 STD EFF	No	STD	No	No	2	420.58	236.32	39.39	186.86	58.00	421.82	227.72	119.76	—	39.76
			Yes	No	2	481.08	296.82	39.39	247.36	58.00	482.32	288.22	119.76	—	39.76
		HIGH	No	No	2	420.58	228.80	49.90	186.86	52.61	421.82	227.72	119.76	—	50.54
			Yes	No	2	481.08	289.30	49.90	247.36	52.61	482.32	288.22	119.76	—	50.54
	Yes	STD	No	No	2	444.58	260.32	39.39	186.86	58.00	445.82	251.72	119.76	195.56	39.76
			Yes	No	2	505.08	320.82	39.39	247.36	58.00	506.32	312.22	119.76	256.06	39.76
		HIGH	No	No	2	444.58	252.80	49.90	186.86	52.61	445.82	251.72	119.76	195.56	50.54
			Yes	No	2	505.08	313.30	49.90	247.36	52.61	506.32	312.22	119.76	256.06	50.54
120 HI EFF 130 ALL 150 STD EFF	No	STD	No	No	3	472.58	236.32	39.39	186.86	58.00	473.82	331.72	171.76	—	39.76
			Yes	No	3	533.08	296.82	39.39	247.36	58.00	534.32	292.22	171.76	—	39.76
		HIGH	No	No	3	472.58	228.80	49.90	186.86	52.61	473.82	331.72	171.76	—	50.54
			Yes	No	3	533.08	289.30	49.90	247.36	52.61	534.32	392.22	171.76	—	50.54
	Yes	STD	No	No	3	496.58	260.32	39.39	186.86	58.00	497.82	355.72	171.76	195.56	39.76
			Yes	No	3	557.08	320.82	39.39	247.36	58.00	558.32	416.22	171.76	256.06	39.76
		HIGH	No	No	3	496.58	252.80	49.90	186.86	52.61	497.82	355.72	171.76	195.56	50.54
			Yes	No	3	557.08	313.30	49.90	247.36	52.61	558.32	416.22	171.76	256.06	50.54

50N 120-150 CONDENSER POSITION 6, OPTION 9 AND 10

UNIT SIZE	COND COILS 2V	COND COILS 3V	LOW SOUND 10B / 10D	DIM "S" (in.)
120 STD EFF	Yes	—	No	96.62
	Yes	—	Yes	102.06
120 HI EFF	—	Yes	Yes	102.06
	—	Yes	Yes	102.06
130 STD EFF	—	Yes	No	96.62
130 HI EFF	—	Yes	Yes	102.06
150 STD EFF	—	Yes	Yes	102.06

Fig. 12 — 50N Unit Sizes R, S, T — without Plenum, without ERV (120-150 Ton Rooftop Unit) (cont)

NOTES:
1. DIMENSIONS ARE IN INCHES.

2. UNIT WEIGHT AND CENTER OF GRAVITY INCLUDES ECONOMIZER, LARGEST INDOOR FAN MOTOR AND HIGH CAPACITY EVAPORATOR COIL.
3. TOP COIL DO NOT RESTRICT CONDENSER FANS ECONOMIZER END - 10'-0"
4. SIDES AND CONDENSER END 6'-0" FOR SMALLER SERVICE AND OPERATIONAL CLEARANCES. CONTACT MANUFACTURER FOR RECOMMENDATIONS FOR SUGGESTED FIELD CONNECTIONS TO MAKE INSIDE OR OUTSIDE OF DUCT FLANGES.
5. WHEN UNIT IS SLAB MOUNTED ALLOW ADEQUATE HEIGHT FOR CONDENSATE DRAIN TRAP.
6. CONDENSATE DRAIN TRAP ARE SHIPPED INSIDE OF UNIT.
7. HEAD RECLAIM COIL DIMENSIONS (MINIMUM)
 - LENGTH (HEADER INCLUDED): 121"
 - WIDTH: 6'-0"
 - HEIGHT: 74'-50"
8. HEAT RECLAIM COIL FIELD SUPPLIED OR ECONOMIZER END - 10'-0"
9. PIPE CHASE LOCATIONS ARE RECOMMENDATIONS ONLY. OPENINGS ARE NOT FACTORY PROVIDED.
10. OPERATIONAL FACTORY SUPPLIED HOT WATER AND STEAM COILS ON UNITS WITHOUT ELECTRIC HEAT.
 - LENGTH: 108'-75"
 - WIDTH: 6'-00"
 - HEIGHT: 74'-50"
 - TUBE O. D.: 1/2" - ROWS 2
 - PIPE SIZE 1 1/2" - NPT
11. STEAM COIL DIMENSIONS:
 - LENGTH: 5'-00"
 - HEIGHT: 66'-00"
 - TUBE O. D.: 1'-00" - ROWS 2
 - PIPE SIZE 2 1/2" - NPT
 - TUBE O. D.: 1'-00" - ROWS 2
 - PIPE SIZE 2 1/2" - NPT

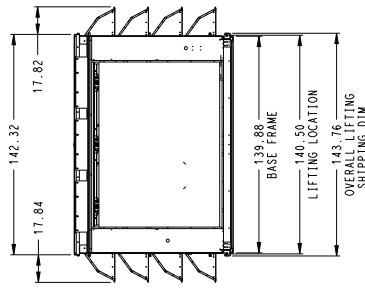
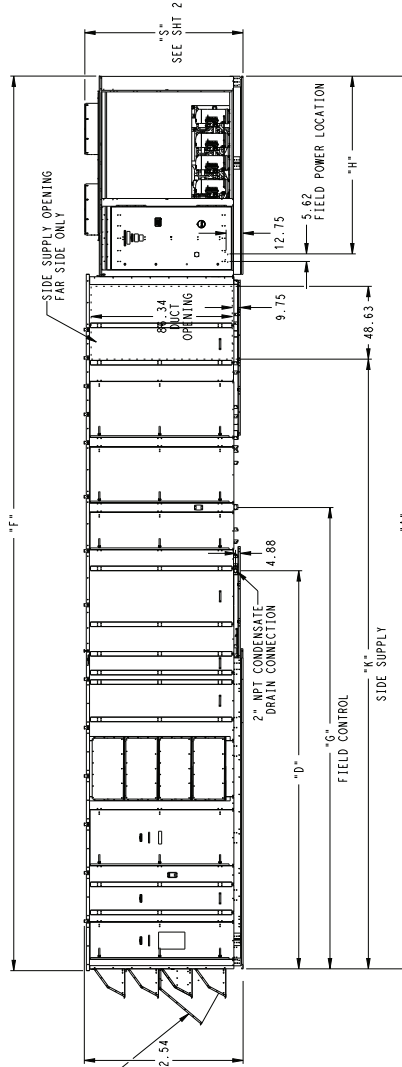
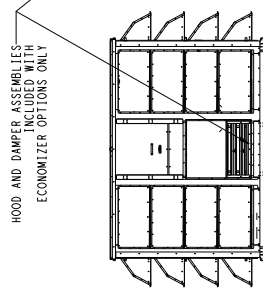
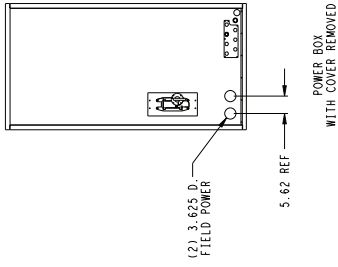
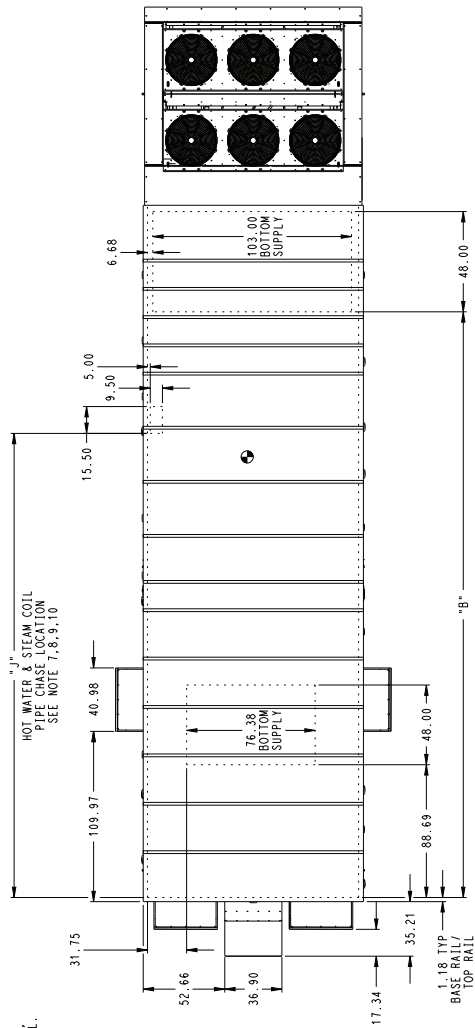
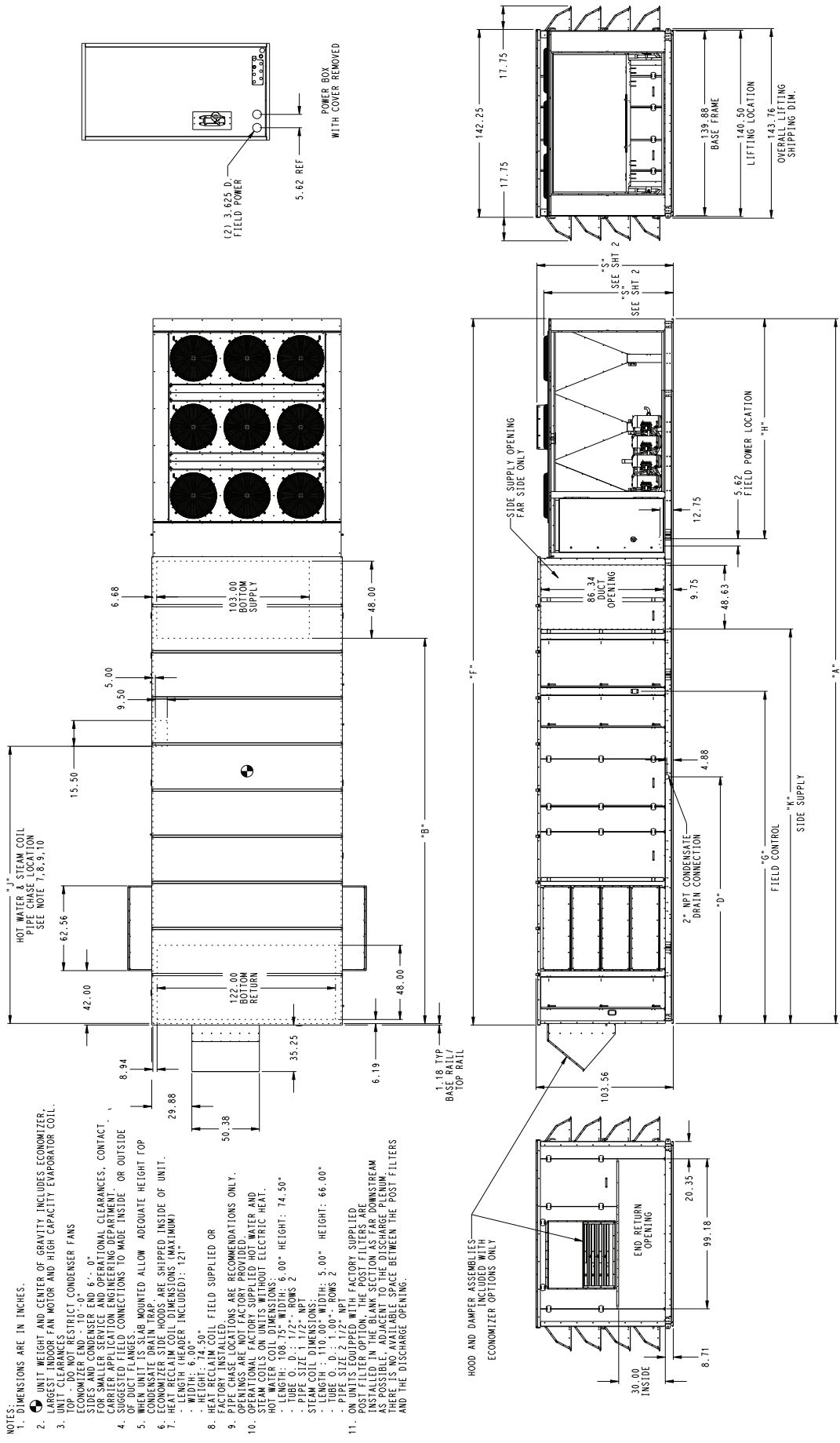

Fig. 13 — 50N Unit Sizes R, S, T — with Plenum, without Electric Heat, with Blank Section, with ERV (120-150 Ton Rooftop Unit)

SIZE (TON) EFF	EXTENDED CHASSIS	FIELD USE FILTER SECTION	BLANK SECTION (ft)	2-PIECE UNIT	CONDENSER # OF V'S	A (in.)	B (in.)	D (in.)	F (in.)	G (in.)	H (in.)	J (in.)	K (in.)
120 STD EFF	No	No	4	Yes	2	576.55	392.86	257.12	577.79	297.94	119.76	—	391.80
		No	8	Yes	2	624.80	441.11	257.12	626.04	297.94	119.76	—	440.05
	Yes	No	4	Yes	2	600.55	416.86	257.12	601.79	321.94	119.76	265.85	415.80
		No	8	Yes	2	648.80	465.11	257.12	650.04	321.94	119.76	265.85	464.05
120 HI EFF 130 ALL 150 STD EFF	No	No	4	Yes	3	628.55	392.86	257.12	629.79	297.94	171.76	—	391.80
		No	8	Yes	3	676.80	441.11	257.12	678.04	297.94	171.76	—	440.05
	Yes	No	4	Yes	3	652.55	416.86	257.12	653.79	321.94	171.76	265.85	415.80
		No	8	Yes	3	700.80	465.11	257.12	702.04	321.94	171.76	265.85	464.05

50N 120-150 CONDENSER POSITION 6, OPTION 9 AND 10				
UNIT SIZE	COND COILS 2V	COND COILS 3V	LOW SOUND 10B / 10D	DIM "S" (in.)
120 STD EFF	Yes	—	No	96.62
	Yes	—	Yes	102.06
120 HI EFF	—	Yes	Yes	102.06
130 STD EFF	—	Yes	No	96.62
130 HI EFF	—	Yes	Yes	102.06
	—	Yes	Yes	102.06
150 STD EFF	—	Yes	Yes	102.06

**Fig. 13 — 50N Unit Sizes R, S, T — with Plenum, without Electric Heat,
with Blank Section, with ERV (120-150 Ton Rooftop Unit) (cont)**



- NOTES:
1. DIMENSIONS ARE IN INCHES.
 2. UNIT WEIGHT AND CENTER OF GRAVITY INCLUDES ECONOMIZER, LARGEST INDOOR FAN MOTOR AND HIGH CAPACITY EVAPORATOR COIL.
 3. TOP - DO NOT RESTRICT CONDENSER FANS
 4. ECONOMIZER END - 10'-0" ONAL CLEARANCES, CONTACT FOR SERVICE AND OPERATIONS. SUGGESTED FIELD CONNECTIONS TO MAKE INSIDE OR OUTSIDE OF DUCT FLANGES.
 5. WHEN UNIT IS SLAB MOUNTED ALLOW ADEQUATE HEIGHT TOP CONDENSATE DRAIN TRAP ARE SHIPPED INSIDE OF UNIT.
 6. HEAT RECLAIM COIL DIMENSIONS (MAXIMUM)
 - LENGTH (HEADER INCLUDED): 121"
 - WIDTH: 6'-0"
 - HEIGHT: 74'-50"
 7. FACTORY INSTALLED.
 8. PIPE CHASE LOCATIONS ARE RECOMMENDATIONS ONLY. OPERATIONS ARE NOT FACTORY PROVIDED.
 9. OPERATIONAL FACTORY SUPPLIED HOT WATER AND HOT WATER COIL DIMENSIONS:
 - LENGTH: 108'-75"
 - WIDTH: 6'-00"
 - HEIGHT: 74'-50"
 - TUBE O. D.: 1/2" - ROWS 2
 - TUBE O. D.: 1/2" - ROWS 2
 - STRIKE STYLE DIMENSION
 - LENGTH: 110'-00"
 - WIDTH: 5'-00"
 - HEIGHT: 66'-00"
 - PIPE SIZE 2 1/2" NPT
 10. ON UNITS EQUIPPED WITH FACTORY SUPPLIED ECONOMIZER, THE ECONOMIZER SHOULD BE INSTALLED IN THE BLANK SECTION AS FAR DOWNSTREAM AS POSSIBLE, ADJACENT TO THE DISCHARGE PLENUM. THERE IS NO AVAILABLE SPACE BETWEEN THE POST FILTERS AND THE DISCHARGE OPENING.

Fig. 14 — 50N Unit Sizes R, S, T — with Plenum, with Electric Heat, with or without Blank Section, without ERV; with Plenum, without Electric Heat, without Blank Section, without ERV (120-150 Ton Rooftop Unit)

SIZE (TON)EFF	EXTENDED CHASSIS	FIELD USE FILTER SECTION	BLANK SECTION (ft)	2-PIECE UNIT	CONDENSER # OF V'S	A (in.)	B (in.)	D (in.)	F (in.)	G (in.)	H (in.)	J (in.)	K (in.)	
120 STD EFF	No	No	No	No	2	458.04	274.35	186.86	459.28	227.68	119.76	—	273.29	
			4	Yes	2	581.29	397.60	205.11	582.53	245.93	119.76	—	296.54	
			8	Yes	2	629.54	445.85	205.11	630.78	245.93	119.76	—	444.79	
		Yes	No	No	No	2	518.54	334.85	247.36	519.78	288.18	119.76	—	333.79
				4	Yes	2	641.79	458.10	265.61	643.03	306.43	119.76	—	457.04
				8	Yes	2	690.04	506.35	265.61	691.28	306.43	119.76	—	505.29
	Yes	No	No	No	No	2	482.04	298.35	186.86	483.28	251.68	119.76	195.56	297.29
				4	Yes	2	605.29	421.60	205.11	606.53	269.93	119.76	213.81	420.54
				8	Yes	2	653.54	469.85	205.11	654.78	269.93	119.76	213.81	468.79
		Yes	No	No	No	2	542.54	358.85	247.36	543.78	312.18	119.76	256.06	357.79
				4	Yes	2	665.79	482.10	265.61	667.03	330.43	119.76	274.31	481.04
				8	Yes	2	714.04	530.35	265.61	715.28	330.43	119.76	274.31	529.29

50N 120-150 CONDENSER POSITION 6, OPTION 9 AND 10				
UNIT SIZE	COND COILS 2V	COND COILS 3V	LOW SOUND 10B / 10D	DIM "S" (in.)
120 STD EFF	Yes	—	No	96.62
	Yes	—	Yes	102.06
120 HI EFF	—	Yes	Yes	102.06
130 STD EFF	—	Yes	No	96.62
	—	Yes	Yes	102.06
130 HI EFF	—	Yes	Yes	102.06
150 STD EFF	—	Yes	Yes	102.06

**Fig. 14 — 50N Unit Sizes R, S, T —
with Plenum, with Electric Heat, with or without Blank Section, without ERV;
with Plenum, without Electric Heat, without Blank Section, without ERV (120-150 Ton Rooftop Unit)**

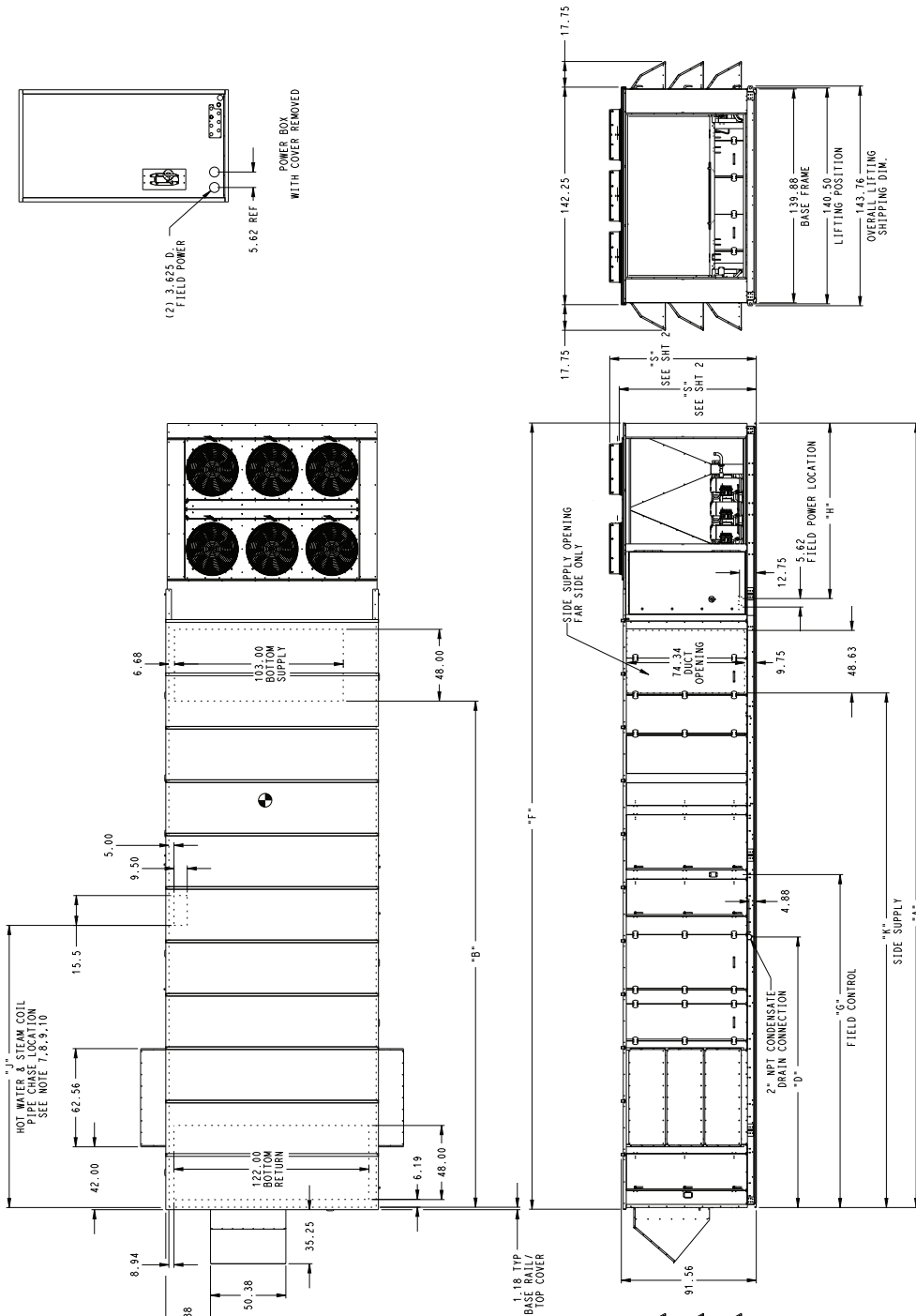

- NOTES:
1. DIMENSIONS ARE IN INCHES.
 2. UNIT WEIGHT AND CENTER OF GRAVITY INCLUDES ECONOMIZER, LARGEST INDOOR FAN MOTOR AND HIGH CAPACITY EVAPORATOR COIL.
 3. TOP AND BOTTOM CLEARANCES TO BE MAINTAINED AS SHOWN. UNITS WITH CONDENSER END 6" - 0" FOR SMALLER SERVICE AND OPERATIONAL CLEARANCES, CONTACT CARRIER APPLICATION ENGINEERING DEPARTMENT.
 4. ALL DUCT CONNECTIONS TO BE MADE INSIDE OR OUTSIDE OF DUCT FLANGES.
 5. WHEN UNIT IS SLAB MOUNTED ALLOW ADEQUATE HEIGHT FOR CONDENSATE DRAIN TRAP. ARE SHIPPED INSIDE OF UNIT.
 6. HEAT RECLAIM COIL DIMENSIONS (MAXIMUM):
 - LENGTH (HEADER INCLUDED): 121"
 - WIDTH: 6' 00"
 - HEIGHT: 6' 00"
 7. HEAT RECLAIM COIL FIELD SUPPLIED OR FACTORY INSTALLED.
 8. PIPE CHASE LOCATIONS ARE RECOMMENDATIONS ONLY. OPERATIONAL FACTORY SUPPLIED HOT WATER AND STEAM COILS ON UNITS WITHOUT ELECTRIC HEAT.
 9. HOT WATER COIL DIMENSIONS:
 - TUBE O. D.: 1 1/2" - ROWS 2
 - PIPE SIZE 1 1/2" - NPT
 - STEAM COIL DIMENSIONS: 5.00" HEIGHT: 54.00"
 - TUBE O. D.: 1.00" - ROWS 2
 - PIPE SIZE 2 1/2" - NPT
 10. ON UNITS EQUIPPED WITH FACTORY SUPPLIED CONDENSATE DRAIN TRAP, THE TRAP SHALL BE INSTALLED IN THE BLANK SECTION AS FAR DOWNSTREAM AS POSSIBLE, ADJACENT TO THE DISCHARGE PLENUM. THERE IS NO AVAILABLE SPACE BETWEEN THE POST FILTERS AND THE DISCHARGE OPENING.

Fig. 15 — 50N Unit Sizes N, P, Q — with Plenum, with Electric Heat, with or without Blank Section, without ERV; with Plenum, without Electric Heat, without ERV (75-105 Ton Rooftop Unit)

SIZE (TON) EFF	EXTENDED CHASSIS	SUPPLY FAN TYPE	FIELD USE FILTER SECTION	BLANK SECTION (ft)	2-PIECE UNIT	CONDENSER # OF V'S	A (in.)	B (in.)	D (in.)	F (in.)	G (in.)	H (in.)	J (in.)	K (in.)
75 All 90 STD EFF 105 STD EFF	NO	STD	No	No	No	2	433.11	249.42	177.02	434.35	202.75	119.76	—	248.36
				4	Yes	2	556.36	372.67	195.27	557.60	221.00	119.76	—	371.61
				8	Yes	2	604.61	420.92	195.27	605.85	221.00	119.76	—	419.86
			Yes	No	No	2	493.61	309.92	237.52	494.85	263.25	119.76	—	308.86
				4	Yes	2	616.86	433.17	255.77	618.10	281.50	119.76	—	432.11
				8	Yes	2	665.11	481.42	255.77	666.35	281.50	119.76	—	480.36
		HIGH	No	No	No	2	448.20	264.51	177.02	449.44	217.84	119.76	—	263.45
				4	Yes	2	571.45	387.76	195.27	572.69	236.09	119.76	—	386.70
				8	Yes	2	619.70	436.01	195.27	620.94	236.09	119.76	—	434.95
			Yes	No	No	2	508.70	325.01	237.52	509.94	278.34	119.76	—	323.95
				4	Yes	2	631.95	448.26	255.77	633.19	296.59	119.76	—	447.20
				8	Yes	2	680.20	496.51	255.77	681.44	296.59	119.76	—	495.45
	YES	STD	No	No	No	2	457.11	273.42	177.02	458.35	226.75	119.76	185.75	272.36
				4	Yes	2	580.36	396.67	195.27	581.60	245.00	119.76	204.00	395.61
				8	Yes	2	628.61	444.92	195.27	629.85	245.00	119.76	204.00	443.86
			Yes	No	No	2	517.61	333.92	237.52	518.85	287.25	119.76	246.25	332.86
				4	Yes	2	640.86	457.17	255.77	642.10	305.50	119.76	264.50	456.11
				8	Yes	2	689.11	505.42	255.77	690.35	305.50	119.76	264.50	504.36
		HIGH	No	No	No	2	472.20	288.51	177.02	473.44	241.84	119.76	185.75	287.45
				4	Yes	2	595.45	411.76	195.27	596.69	260.09	119.76	204.00	410.70
				8	Yes	2	643.70	460.01	195.27	644.94	260.09	119.76	204.00	458.95
			Yes	No	No	2	532.70	349.01	237.52	533.94	302.34	119.76	246.25	347.95
				4	Yes	2	655.95	472.26	255.77	657.19	320.59	119.76	264.50	471.20
				8	Yes	2	704.20	520.51	255.77	705.44	320.59	119.76	264.50	519.45
90 HI EFF 105 HI EFF	NO	STD	No	No	No	3	485.11	249.42	177.02	486.35	202.75	171.76	—	248.36
				4	Yes	3	608.36	372.67	195.27	609.60	221.00	171.76	—	371.61
				8	Yes	3	656.61	420.92	195.27	657.85	221.00	171.76	—	419.86
			Yes	No	No	3	545.61	309.92	237.52	546.85	263.25	171.76	—	308.86
				4	Yes	3	668.86	433.17	255.77	670.10	281.50	171.76	—	432.11
				8	Yes	3	717.11	481.42	255.77	718.35	281.50	171.76	—	480.36
		HIGH	No	No	No	3	500.20	264.51	177.02	501.44	217.84	171.76	—	263.45
				4	Yes	3	623.45	387.76	195.27	624.69	236.09	171.76	—	386.70
				8	Yes	3	671.70	436.01	195.27	672.94	236.09	171.76	—	434.95
			Yes	No	No	3	560.70	325.01	237.52	561.94	278.34	171.76	—	323.95
				4	Yes	3	683.95	448.26	255.77	685.19	296.59	171.76	—	447.20
				8	Yes	3	732.20	496.51	255.77	733.44	296.59	171.76	—	495.45
	YES	STD	No	No	No	3	509.11	273.42	177.02	510.35	226.75	171.76	185.75	272.36
				4	Yes	3	632.36	396.67	195.27	633.60	245.00	171.76	204.00	395.61
				8	Yes	3	680.61	444.92	195.27	681.85	245.00	171.76	204.00	443.86
			Yes	No	No	3	569.61	333.92	237.52	570.85	287.25	171.76	246.25	332.86
				4	Yes	3	692.86	457.17	255.77	694.10	305.50	171.76	264.50	456.11
				8	Yes	3	741.11	505.42	255.77	742.35	305.50	171.76	264.50	504.36
		HIGH	No	No	No	3	524.20	288.51	177.02	525.44	241.84	171.76	185.75	287.45
				4	Yes	3	647.45	411.76	195.27	648.69	260.09	171.76	204.00	410.70
				8	Yes	3	695.70	460.01	195.27	696.94	260.09	171.76	204.00	458.95
			Yes	No	No	3	584.70	349.01	237.52	585.94	302.34	171.76	246.25	347.95
				4	Yes	3	707.95	472.26	255.77	709.19	320.59	171.76	264.50	471.20
				8	Yes	3	756.20	520.51	255.77	757.44	320.59	171.76	264.50	519.45

50N 75-105 CONDENSER POSITION 6, OPTION 9 AND 10

UNIT SIZE	COND COILS 2V	COND COILS 3V	LOW SOUND 10B / 10D	DIM "S" (in.)
75 ALL	Yes	—	No	92.62
	Yes	—	Yes	98.06
90 STD EFF	Yes	—	No	92.62
	Yes	—	Yes	98.06
90 HI EFF	—	Yes	Yes	98.06
105 STD EFF	Yes	—	No	98.06
	Yes	—	Yes	98.06
105 HI EFF	—	Yes	Yes	98.06

Fig. 15 — 50N Unit Sizes N, P, Q — with Plenum, with Electric Heat, with or without Blank Section, without ERV; with Plenum, without Electric Heat, without Blank Section, without ERV (75-105 Ton Rooftop Unit)

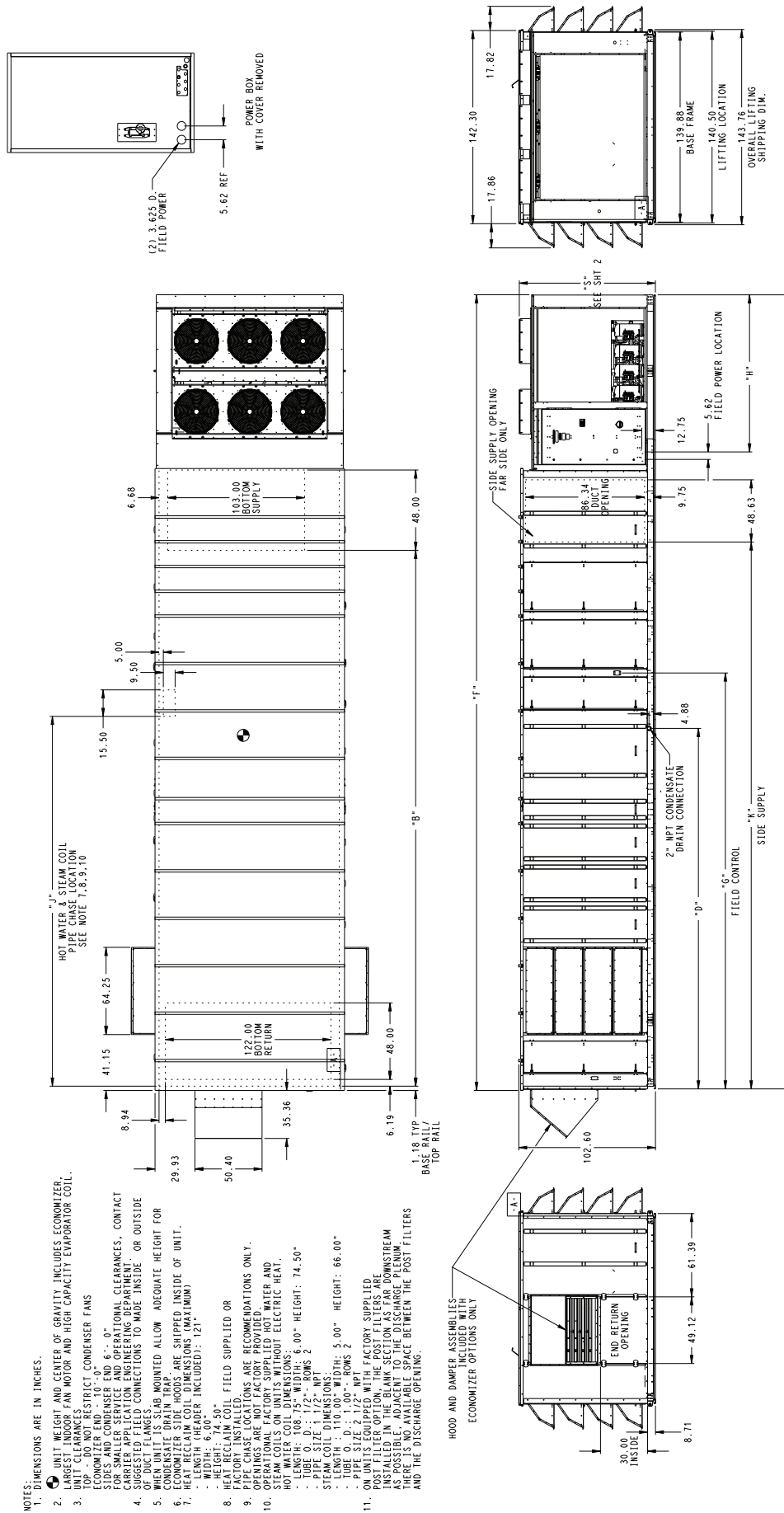

Fig. 16 — 50N Unit Sizes R, S, T — with Plenum, without Electric Heat, with Blank Section, without ERV (120-150 Ton Rooftop Unit)

SIZE (TON) EFF	EXTENDED CHASSIS	FIELD USE FILTER SECTION	BLANK SECTION (ft)	2-PIECE UNIT	CONDENSER # OF V'S	A (in.)	B (in.)	D (in.)	F (in.)	G (in.)	H (in.)	J (in.)	K (in.)		
120 STD EFF	No	No	4	No	2	506.29	322.60	186.86	507.53	227.68	119.76	—	321.54		
			8	No	2	554.54	370.85	186.86	555.78	227.68	119.76	—	369.79		
		Yes	No	4	No	2	566.79	383.10	247.36	568.03	288.18	119.76	—	382.04	
				8	Yes	2	633.29	449.60	265.61	634.53	306.43	119.76	—	448.54	
	Yes	No	No	4	No	2	530.29	346.6	186.86	531.53	251.68	119.76	195.59	345.54	
				8	No	2	578.54	394.85	186.86	579.78	251.68	119.76	195.59	393.79	
		Yes	No	4	No	2	590.79	407.10	247.36	592.03	312.18	119.76	195.59	406.04	
				8	Yes	2	657.29	473.60	265.61	658.53	330.43	119.76	213.84	472.54	
120 HI EFF 130 ALL	No	No	8	Yes	3	624.79	389.10	205.11	626.03	245.93	171.76	—	388.04		
			4	Yes	3	637.04	401.35	265.61	638.28	306.43	171.76	—	400.29		
		Yes	No	4	No	3	582.29	346.60	186.86	583.53	251.68	171.76	195.59	345.54	
				8	Yes	3	648.79	413.10	205.11	650.03	269.93	171.76	213.84	412.04	
	Yes	Yes	No	4	Yes	3	661.04	425.35	265.61	662.28	330.43	171.76	213.84	424.29	
				8	Yes	3	709.29	473.60	265.61	710.53	330.43	171.76	213.84	472.54	
		Yes	Yes	No	4	No	3	558.29	322.60	186.86	559.53	227.68	119.76	—	321.54
					8	Yes	3	624.79	389.10	205.11	626.03	245.93	171.76	—	388.04
150 STD EFF	No	Yes	4	Yes	3	637.04	401.35	265.61	638.28	306.43	171.76	—	400.29		
			8	Yes	3	685.29	449.60	265.61	686.53	306.43	171.76	—	448.54		
		Yes	No	4	No	3	582.29	346.60	186.86	583.53	251.68	171.76	195.59	345.54	
				8	Yes	3	648.79	413.10	205.11	650.03	269.93	171.76	213.84	412.04	
	Yes	Yes	No	4	Yes	3	661.04	425.35	265.61	662.28	330.43	171.76	213.84	424.29	
				8	Yes	3	709.29	473.60	265.61	710.53	330.43	171.76	213.84	472.54	

50N 120-150 CONDENSER POSITION 6, OPTION 9 AND 10

UNIT SIZE	COND COILS 2V	COND COILS 3V	LOW SOUND 10B / 10D	DIM "S" (in.)
120 STD EFF	Yes	—	No	96.62
	Yes	—	Yes	102.06
120 HI EFF	—	Yes	Yes	102.06
130 STD EFF	—	Yes	No	96.62
	—	Yes	Yes	102.06
130 HI EFF	—	Yes	Yes	102.06
150 STD EFF	—	Yes	Yes	102.06

Fig. 16 — 50N Unit Sizes R, S, T, with Plenum, without Electric Heat, with Blank Section, without ERV (120-150 Ton Rooftop Unit) (cont)

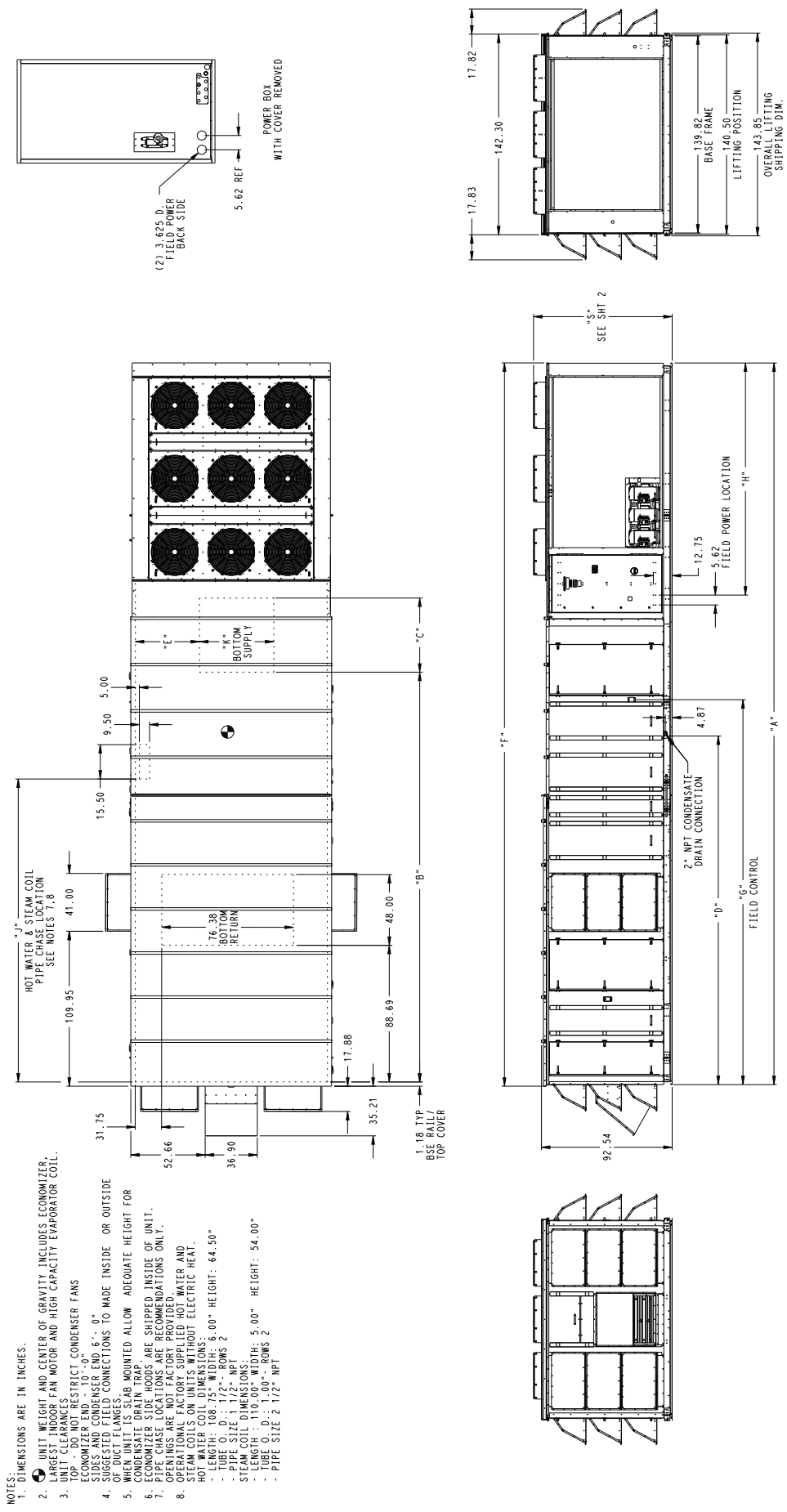

Fig. 17 —50N Unit Sizes N, P, Q — without Plenum, with ERV (75-105 Ton Rooftop Unit)

SIZE (TON) EFF	EXTENDED CHASSIS	SUPPLY FAN TYPE	FIELD USE FILTER SECTION	BLANK SECTION	2-PIECE UNIT	CONDENSER # OF V'S	A (in.)	B (in.)	C (in.)	D (in.)	E (in.)	F (in.)	G (in.)	H (in.)	J (in.)	K (in.)
75 ALL 90 STD EFF 105 STD EFF	No	STD	No	No	Yes	2	459.91	284.53	36.32	247.26	60.50	461.15	273.01	119.76	—	34.76
		HIGH	No	No	Yes	2	481.00	289.22	49.90	247.26	52.61	482.24	288.10	119.76	—	50.24
	Yes	STD	No	No	Yes	2	483.91	308.53	36.32	247.26	60.50	485.15	297.01	119.76	256.61	34.76
		HIGH	No	No	Yes	2	505.00	313.22	49.90	247.26	52.61	506.24	312.10	119.76	256.61	50.54
90 HI EFF 105 HI EFF	No	STD	No	No	Yes	3	511.91	284.53	36.32	247.26	60.50	513.15	273.01	171.76	—	34.76
		HIGH	No	No	Yes	3	533.00	289.22	49.90	247.26	52.61	534.24	288.10	171.76	—	50.54
	Yes	STD	No	No	Yes	3	535.91	308.53	36.32	247.26	60.50	537.15	297.01	171.76	256.61	34.76
		HIGH	No	No	Yes	3	557.00	313.22	49.90	247.26	52.61	558.24	312.10	171.76	256.61	50.54

50N 75-105 CONDENSER POSITION 6, OPTION 9 AND 10

UNIT SIZE	COND COILS 2V	COND COILS 3V	LOW SOUND 10B / 10D	DIM "S" (in.)
75 ALL	Yes	—	No	92.62
	Yes	—	Yes	98.06
90 STD EFF	Yes	—	No	92.62
	Yes	—	Yes	96.62
90 HI EFF	—	Yes	Yes	98.06
105 STD EFF	Yes	—	No	98.06
	Yes	—	Yes	98.06
105 HI EFF	—	Yes	Yes	98.06

**Fig. 17 — 50N Unit Sizes N, P, Q —
without Plenum, with ERV (75-105 Ton Rooftop Unit) (cont)**

- NOTES:
1. DIMENSIONS ARE IN INCHES.
 2. UNIT WEIGHT AND CENTER OF GRAVITY INCLUDES ECONOMIZER, WHEELER FAN MOTOR AND HIGH CAPACITY EVAPORATOR COIL.
 3. TOP - DO NOT RESTRICT CONDENSER FANS
 4. SUGGESTED FIELD CONNECTIONS TO MADE INSIDE OR OUTSIDE OF DUCT FLANGES.
 5. ECONOMIZER IS MOUNTED ALLOW ADEQUATE HEIGHT FOR CONDENSATE DRAIN TRAP.
 6. ECONOMIZER SIDE HOODS ARE SHIPPED INSIDE OF UNIT.
 7. PIPE CHASE LOCATIONS ARE RECOMMENDATIONS ONLY. OPENINGS ARE NOT FACTORY PROVIDED.
 8. OPERATIONAL FACTORY SUPPLIED HOT WATER AND STEAM COILS ON UNITS WITHOUT ELECTRIC HEAT.
 - LENGTH: 108.75" WIDTH: 6.00" HEIGHT: 64.50"
 - TUBE O. D.: 1 1/2" ROWS 2
 - PIPE SIZE 1 1/2" NPT
 9. STEAM COIL DIMENSIONS:
 - LENGTH: 110.00" WIDTH: 5.00" HEIGHT: 54.00"
 - PIPE O. D.: 1.50" ROWS 2
 - PIPE SIZE 2 1/2" NPT

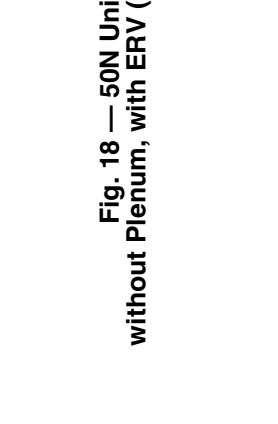
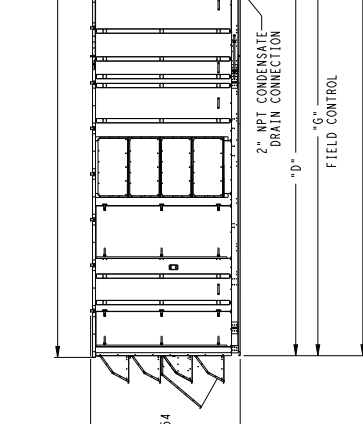
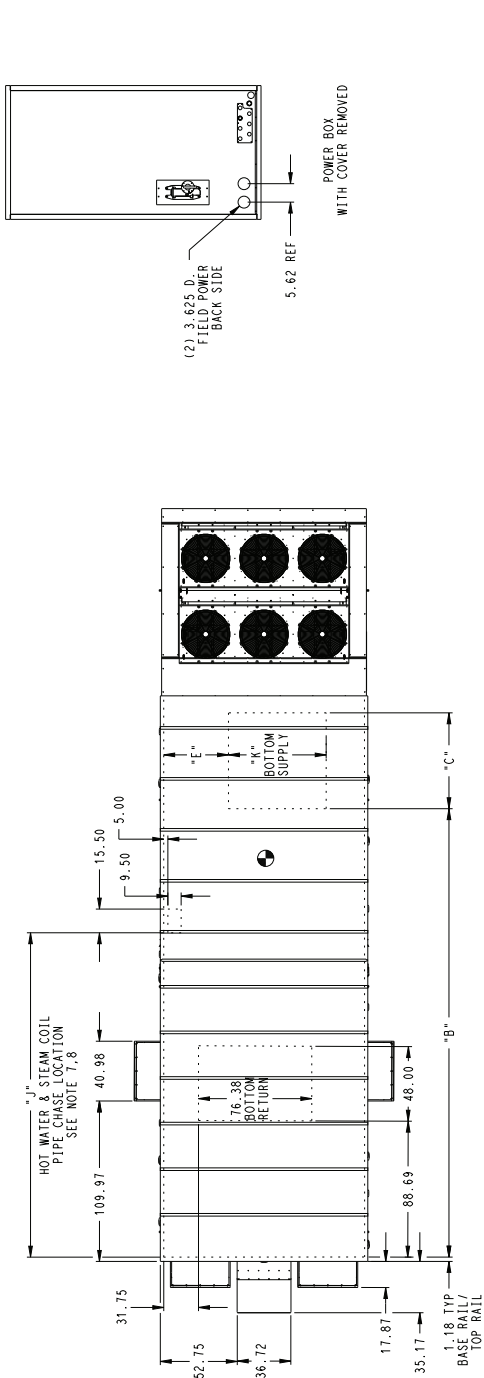

Fig. 18 — 50N Unit Sizes R, S, T — without Plenum, with ERV (120-150 Ton Rooftop Unit)

SIZE (TON) EFF	EXTENDED CHASSIS	SUPPLY FAN TYPE	FIELD USE FILTER SECTION	BLANK SECTION	2-PIECE UNIT	CONDENSER # OF V'S	A (in.)	B (in.)	C (in.)	D (in.)	E (in.)	F (in.)	G (in.)	H (in.)	J (in.)	K (in.)
120 STD EFF	No	STD	No	No	Yes	2	490.84	306.58	39.39	257.12	58.00	492.08	297.97	119.76	—	39.76
		HIGH	No	No	Yes	2	49.084	299.06	49.90	257.12	52.61	492.08	297.97	119.76	—	50.54
	Yes	STD	No	No	Yes	2	514.84	330.58	39.39	257.12	58.00	516.08	321.97	119.76	256.06	39.76
		HIGH	No	No	Yes	2	514.84	323.06	49.90	257.12	52.61	516.08	321.97	119.76	256.06	50.54
120 HI EFF 130 ALL 150 STD EFF	No	STD	No	No	Yes	3	542.84	306.58	39.39	257.12	58.00	544.08	349.97	171.76	—	39.76
		HIGH	No	No	Yes	3	542.84	299.06	49.90	257.12	52.61	544.08	349.97	171.76	—	50.54
	Yes	STD	No	No	Yes	3	566.84	330.58	39.39	257.12	58.00	568.08	373.97	171.76	256.06	39.76
		HIGH	No	No	Yes	3	566.84	323.06	49.90	257.12	52.61	568.08	373.97	171.76	256.06	50.54

50N 120-150 CONDENSER POSITION 6, OPTION 9 AND 10				
UNIT SIZE	COND COILS 2V	COND COILS 3V	LOW SOUND 10B / 10D	DIM "S" (in.)
120 STD EFF	Yes	—	No	96.62
	Yes	—	Yes	102.06
120 HI EFF	—	Yes	Yes	102.06
130 STD EFF	—	Yes	No	96.62
130 HI EFF	—	Yes	Yes	102.06
150 STD EFF	—	Yes	Yes	102.06

Fig. 18 — 50N Unit Sizes R, S, T — without Plenum, with ERV (120-150 Ton Rooftop Unit) (cont)

NOTES:
1. DIMENSIONS ARE IN INCHES.

2. UNIT WEIGHT AND CENTER OF GRAVITY INCLUDES ECONOMIZER, LARGEST INDOOR FAN MOTOR AND HIGH CAPACITY EVAPORATOR COIL.

3. TOP CLING NOT RESTRICT CONDENSER FANS

4. ECONOMIZER END - 10'-0"

5. SIDES AND CONDENSER END 6'-0"

FOR SMALLER SERVICE AND OPERATIONAL CLEARANCES. CONTACT

EARLIER APPLICATION ENGINEERING DEPARTMENT.

6. LOCATIONS OF DUCT FLANGES CONNECTIONS TO MADE INSIDE OR OUTSIDE

OF DUCT ALLOWED TO BE MAINTAINED.

7. WHEN UNIT IS SLAB MOUNTED ALLOW ADEQUATE HEIGHT FOR

CONDENSATE DRAIN TRAP.

8. ECONOMIZER SIDE HOODS ARE SHIPPED INSIDE OF UNIT.

9. THE FOLLOWING DIMENSIONS MAXIMUM)

10. - LENGTH (HEADER INCLUDED): 121"

11. - WIDTH: 6'-0"

12. - HEIGHT: 64'-50"

13. HEAT RECLAIM COIL FIELD SUPPLIED OR

NOT SUPPLIED.

14. FOR SMALLER SERVICE AND OPERATIONAL CLEARANCES. CONTACT

EARLIER APPLICATION ENGINEERING DEPARTMENT.

15. OPERATIONS ARE NOT FACTORY PROVIDED.

16. OPERATIONAL FACTORY SUPPLIED HOT WATER AND

STEAM COILS ON UNITS WITHOUT ELECTRIC HEAT.

17. HOT WATER COIL DIMENSIONS:

- TUBE O. D.: 1 3/8" - ROWS 1

- TUBE O. D.: 1 1/2" - ROWS 2

- PIPE SIZE: 1 1/2" NPT

18. STEAM COIL DIMENSIONS:

- LENGTH: 110'-00"

- WIDTH: 5'-00"

- HEIGHT: 54'-00"

- O. D.: 5'-11/20" ROWS 2

- PIPE SIZE: 1 1/2" NPT

19. ON UNITS EQUIPPED WITH FACTORY SUPPLIED

POST FILTER OPTION, THE POST FILTERS ARE

INSTALLED IN THE BLANK SECTION AS FAR DOWNSTREAM

AS POSSIBLE. ADJACENT TO THE DISCHARGE PLENUM

THE SPACE BETWEEN THE POST FILTERS

AND THE DISCHARGE OPENING.

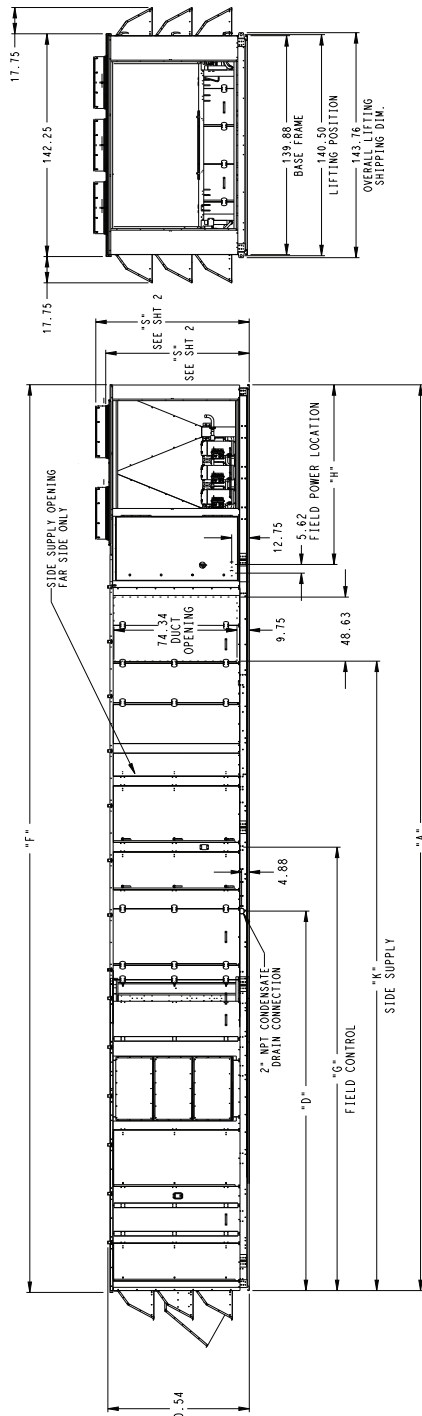
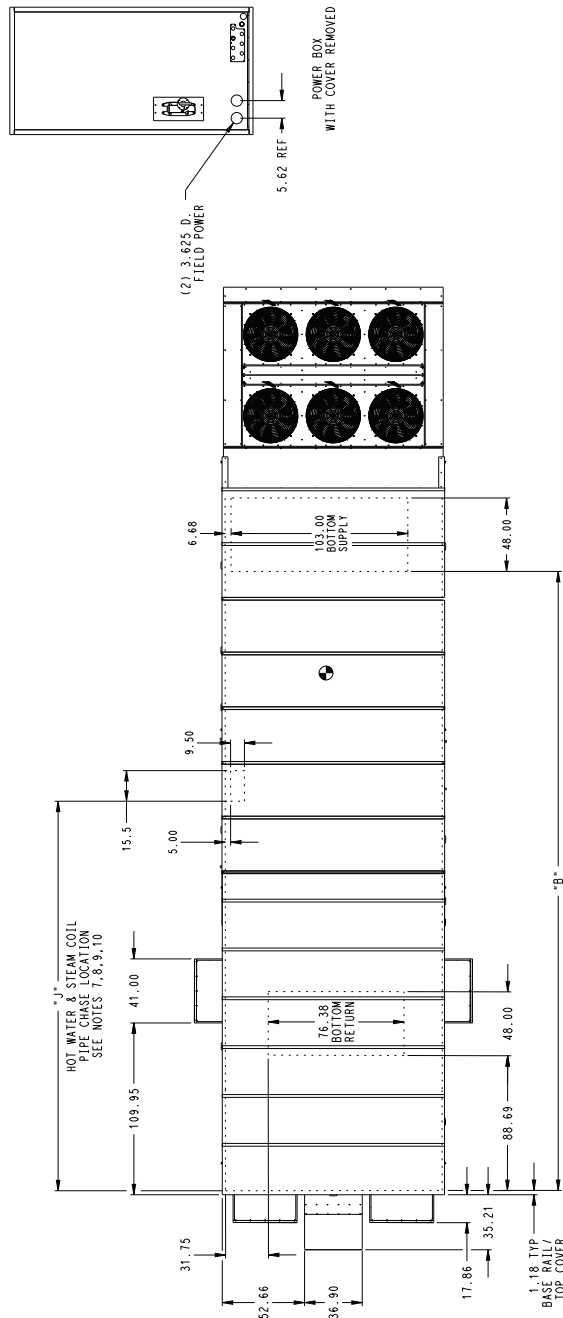

Fig. 19 — 50N Unit Sizes N, P, Q — with Plenum, with Electric Heat, with or without Blank Section, with ERV; with Plenum, without Electric Heat, without Blank Section, with ERV (75-105 Ton Rooftop Unit)

SIZE (TON) EFF	EXTENDED CHASSIS	SUPPLY FAN TYPE	FIELD USE FILTER SECTION	BLANK SECTION (ft)	2-PIECE UNIT	CONDENSER # OF V'S	A (in.)	B (in.)	D (in.)	F (in.)	G (in.)	H (in.)	J (in.)	K (in.)
75 ALL 90 STD EFF 105 STD EFF	No	STD	No	No	Yes	2	503.37	319.68	247.28	504.61	273.01	119.76	—	318.62
				4	Yes	2	608.37	424.68	247.28	609.61	273.01	119.76	—	423.62
				8	Yes	2	656.62	472.93	247.28	657.86	273.01	119.76	—	471.87
		HIGH	No	No	Yes	2	518.46	334.77	247.28	519.70	288.10	119.76	—	333.71
				4	Yes	2	623.37	439.77	247.28	624.70	288.10	119.76	—	438.71
				8	Yes	2	671.71	488.02	247.28	672.95	288.10	119.76	—	486.96
	Yes	STD	No	No	Yes	2	527.37	343.68	247.28	528.61	297.01	119.76	256.01	342.62
				4	Yes	2	632.37	448.68	247.28	633.61	297.01	119.76	256.01	447.62
				8	Yes	2	680.62	496.93	247.28	681.86	297.01	119.76	256.01	495.87
		HIGH	No	No	Yes	2	542.46	358.77	247.28	543.70	312.10	119.76	256.01	357.71
				4	Yes	2	647.46	463.77	247.28	648.70	312.10	119.76	256.01	462.71
				8	Yes	2	695.71	512.02	247.28	696.95	312.10	119.76	256.01	510.96
90 HI EFF 105 HI EFF	No	STD	No	No	Yes	3	555.37	319.68	247.28	556.61	273.01	171.76	—	318.62
				4	Yes	3	660.37	424.68	247.28	661.61	273.01	171.76	—	423.62
				8	Yes	3	708.62	472.93	247.28	709.86	273.01	171.76	—	471.87
		HIGH	No	No	Yes	3	570.46	334.77	247.28	571.70	288.10	171.76	—	333.71
				4	Yes	3	675.46	439.77	247.28	676.70	288.10	171.76	—	438.71
				8	Yes	3	723.71	488.02	247.28	724.95	288.10	171.76	—	486.96
	Yes	STD	No	No	Yes	3	579.37	343.68	247.28	580.61	297.01	171.76	256.01	342.62
				4	Yes	3	684.37	448.68	247.28	685.61	297.01	171.76	256.01	447.62
				8	Yes	3	732.62	496.93	247.28	733.86	297.01	171.76	256.01	495.87
		HIGH	No	No	Yes	3	594.46	358.77	247.28	595.70	312.10	171.76	256.01	357.71
				4	Yes	3	699.46	463.77	247.28	700.70	312.10	171.76	256.01	462.71
				8	Yes	3	747.71	512.02	247.28	748.95	312.10	171.76	256.01	510.96

50N 75-105 CONDENSER POSITION 6, OPTION 9 AND 10

UNIT SIZE	COND COILS 2V	COND COILS 3V	LOW SOUND 10B / 1D	DIM "S" (in.)
75 ALL	Yes	—	No	92.62
	Yes	—	Yes	98.06
90 STD EFF	Yes	—	No	92.62
	Yes	—	Yes	98.06
90 HI EFF	—	Yes	Yes	98.06
105 STD EFF	Yes	—	No	98.06
	Yes	—	Yes	98.06
105 HI EFF	—	Yes	Yes	98.06

**Fig. 19 — 50N Unit Sizes N, P, Q —
with Plenum, with Electric Heat, with or without Blank Section, with ERV;
with Plenum, without Electric Heat, without Blank Section, with ERV (75-105 Ton Rooftop Unit) (cont)**

- NOTES:
1. DIMENSIONS ARE IN INCHES.
 2. UNIT WEIGHT AND CENTER OF GRAVITY INCLUDES ECONOMIZER, LARGEST INDOOR FAN MOTOR AND HIGH CAPACITY EVAPORATOR COIL.
 3. UNIT CLEARANCES
 4. TOP - DO NOT RESTRICT CONDENSER FANS
 5. ECONOMIZER END - 10'-0"
 6. CONDENSER END - 6'-0"
 7. SIDE AND CONDENSER END 6'-0" OPTIONAL CLEARANCES, CONTACT CARROLL TOP ENGINEERING DEPARTMENT OR OUTSIDE CONSULTANT FOR SUGGESTED FIELD CONNECTIONS TO MADE INSIDE OF DUCT FLANGES.
 8. WHEN UNIT IS SLAB MOUNTED ALLOW ADEQUATE HEIGHT FOR CONDENSATE DRAIN TRAP.
 9. ECONOMIZER SIDE HOODS ARE SHIPPED INSIDE OF UNIT.
 10. HEADER HEIGHTS (MAXIMUM)
 11. HEADERS (HEADER INCLUDED): 121"
 - HEIGHT: 6'-00"
 - WIDTH: 74'-50"
 12. HEAT RECLAIM COIL FIELD SUPPLIED OR FACTORY INSTALLED
 13. PIPE CHASE LOCATIONS ARE RECOMMENDATIONS ONLY. OPERATIONAL FACTORY SUPPLIED HOT WATER AND STEAM COILS ON UNITS WITHOUT ELECTRIC HEAT.
 14. HOT WATER COIL DIMENSIONS:
 - LENGTH: 108'-75"
 - WIDTH: 6'-00"
 - HEIGHT: 74'-50"
 - TUBE O. D.: 1 1/2" - ROWS 2
 - PIPE SIZE: 2 1/2" NPT
 15. STEAM COIL DIMENSIONS:
 - LENGTH: 110'-00"
 - WIDTH: 5'-00"
 - HEIGHT: 66'-00"
 - TUBE O. D.: 1'-00"
 - ROWS 2
 - PIPE SIZE 2 1/2" NPT
 16. ON UNITS EQUIPPED WITH FACTORY SUPPLIED POST FILTER OPTION, THE POST FILTERS ARE INSTALLED IN THE BLANK SECTION AS DOWNSTREAM THERE IS NO AVAILABLE SPACE BETWEEN THE POST FILTERS AND THE DISCHARGE OPENING.

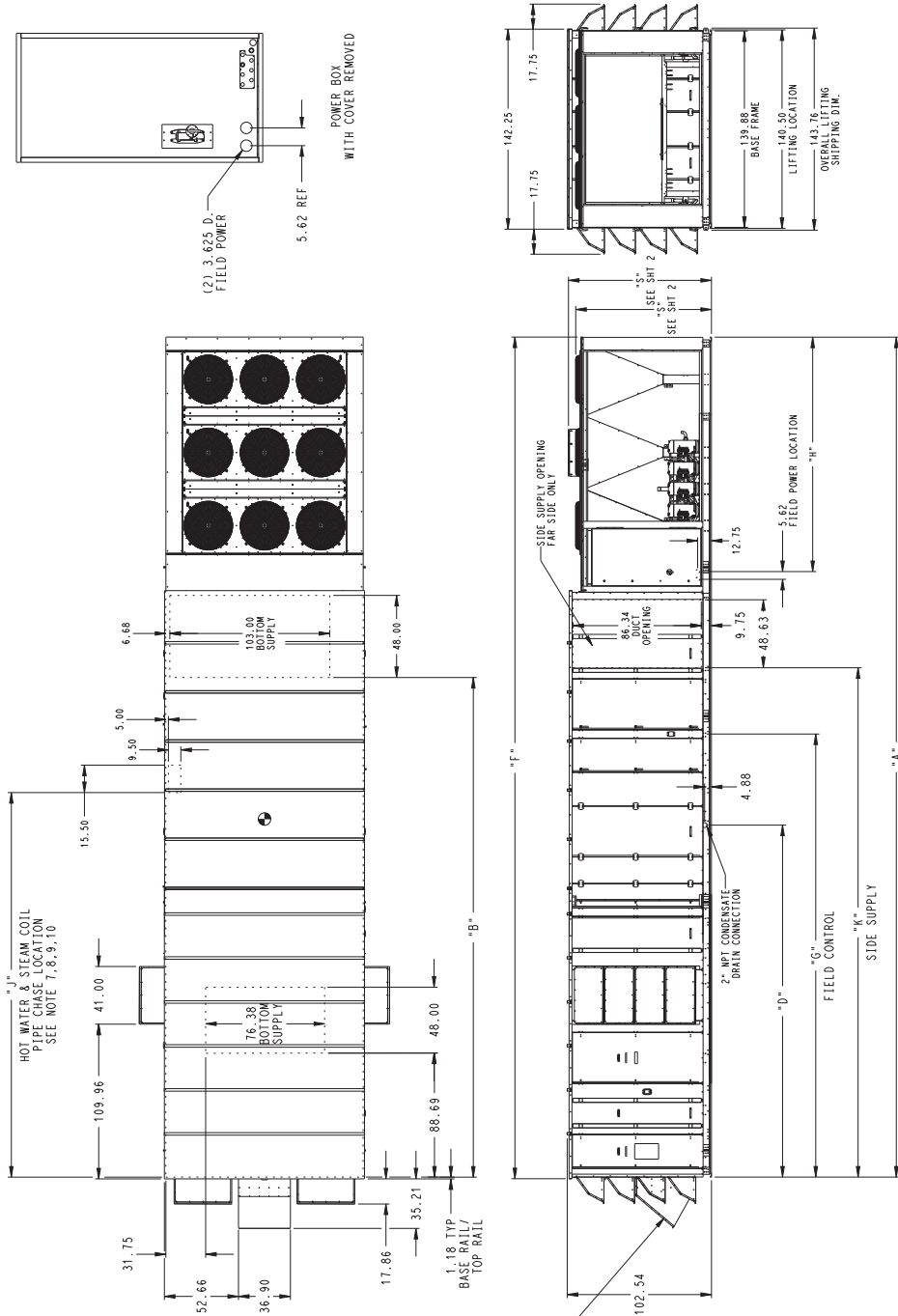
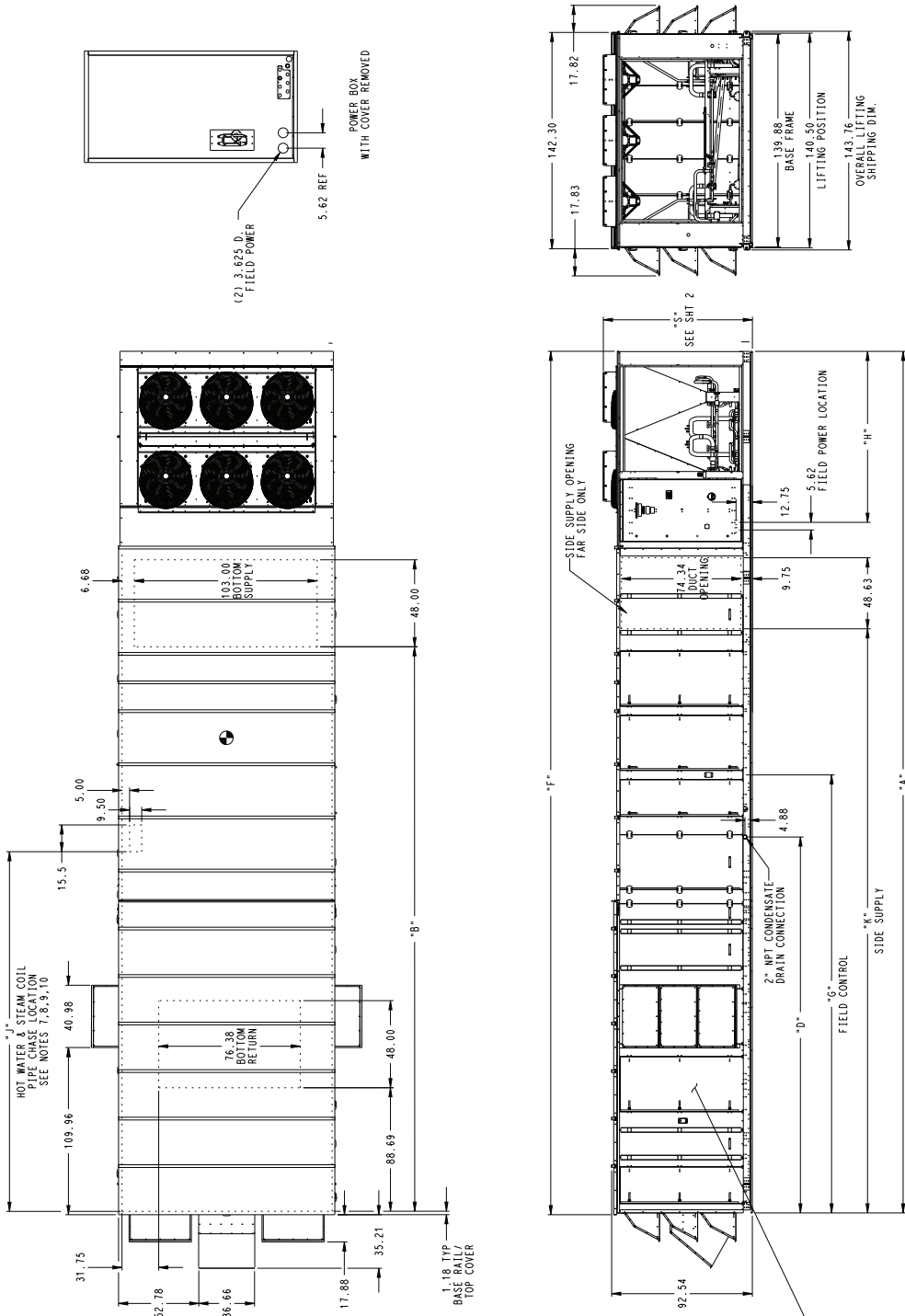

Fig. 20 — 50N Unit Sizes R, S, T —
 with Plenum, with Electric Heat, with or without Blank Section, with ERV;
 with Plenum, without Electric Heat, without Blank Section, with ERV (120-150 Ton Rooftop Unit)

SIZE (TON) EFF	EXTENDED CHASSIS	FIELD USE FILTER SECTION	BLANK SECTION (ft)	2-PIECE UNIT	CONDENSER # OF V'S	A (in.)	B (in.)	D (in.)	F (in.)	G (in.)	H (in.)	J (in.)	K (in.)
120 STD EFF	No	No	No	Yes	2	528.30	344.61	257.12	529.54	297.94	119.94	—	343.55
			4	Yes	2	633.30	449.61	257.12	634.54	297.94	119.76	—	448.55
			8	Yes	2	681.55	497.86	257.12	682.79	297.94	119.76	—	496.80
	Yes	No	No	Yes	2	552.30	368.61	257.12	553.54	321.94	119.76	265.85	367.55
			4	Yes	2	657.30	473.61	257.12	658.54	321.94	119.76	265.85	472.55
			8	Yes	2	705.55	521.86	257.12	706.79	321.94	119.76	265.85	520.80
120 HI EFF 130 ALL 150 STD EFF	No	No	No	Yes	3	580.30	344.61	257.12	581.54	297.94	171.76	—	343.55
			4	Yes	3	685.30	449.61	257.12	686.54	297.94	171.76	—	448.55
			8	Yes	3	733.55	497.86	257.12	734.79	297.94	171.76	—	496.80
	Yes	No	No	Yes	3	604.30	368.61	257.12	605.54	321.94	171.76	265.85	367.55
			4	Yes	3	709.30	473.61	257.12	710.54	321.94	171.76	265.85	472.55
			8	Yes	3	757.55	521.86	257.12	758.79	321.94	171.76	265.85	520.80

50N120-150 CONDENSER POSITION 6, OPTION 9 AND 10				
UNIT SIZE	COND COILS 2V	COND COILS 3V	LOW SOUND 10B / 10D	DIM "S" (in.)
120 STD EFF	Yes	—	No	96.62
	Yes	—	Yes	102.06
120 HI EFF	—	Yes	Yes	102.06
130 STD EFF	—	Yes	No	96.62
	—	Yes	Yes	102.06
130 HI EFF	—	Yes	Yes	102.06
150 STD EFF	—	Yes	Yes	102.06

**Fig. 20 — 50N Unit Sizes R, S, T —
with Plenum, with Electric Heat, with or without Blank Section, with ERV;
with Plenum, without Electric Heat, without Blank Section, with ERV (120-150 Ton Rooftop Unit) (cont)**



- NOTES:
1. DIMENSIONS ARE IN INCHES.
 2. UNIT WEIGHT AND CENTER OF GRAVITY INCLUDES ECONOMIZER, LARGEST INDOOR FAN MOTOR AND HIGH CAPACITY EVAPORATOR COIL.
 3. UNIT CLEARANCES:
 - TO REFRIGERANT CONDENSER FANS: 12"
 - TO ECONOMIZER END: 10'-0"
 - TO CONDENSER END: 6'-0"
 4. FOR SMALLER SERVICE AND OPERATIONAL CLEARANCES, CONTACT SUGGESTED FIELD ENGINEERING DEPARTMENT. SUGGESTED FIELD CONNECTIONS TO MADE INSIDE OR OUTSIDE OF DUCT FLANGES.
 5. WHEN UNIT IS SLAB MOUNTED ALLOW ADEQUATE HEIGHT FOR CONDENSATE DRAIN TRAP. ARE SHIPPED INSIDE OF UNIT.
 6. HEAT RECLAIM COIL DIMENSIONS (MAXIMUM):
 - LENGTH: 108.75" WIDTH: 6.00" HEIGHT: 64.50"
 - PIPE SIZE: 1 1/2" NPS ROWS 2
 7. HEAT RECLAIM COIL FIELD SUPPLIED OR FACTORY INSTALLED.
 8. FACTORY INSTALLATION RECOMMENDATIONS ONLY. OPENINGS ARE NOT FACTORY PROVIDED. WATER AND STEAM COILS ON UNITS WITHOUT ELECTRIC HEAT.
 9. HOT WATER COIL DIMENSIONS:
 - LENGTH: 108.75" WIDTH: 6.00" HEIGHT: 64.50"
 - PIPE SIZE: 1 1/2" NPS ROWS 2
 10. STEAM COIL DIMENSIONS:
 - LENGTH: 110.00" WIDTH: 5.00" HEIGHT: 54.00"
 - PIPE O.D.: 1.50" NPS ROWS 2
 11. ON UNITS EQUIPPED WITH FACTORY SUPPLIED POST FILTER OPTION, THE POST FILTERS ARE INSTALLED IN THE BLANK SECTION AS FAR DOWNSTREAM AS POSSIBLE TO MAINTAIN THE MAXIMUM AVAILABLE SPACE BETWEEN THE POST FILTERS AND THE DISCHARGE OPENING.

Fig. 21 — 50N Unit Sizes N, P, Q — with Plenum, without Electric Heat, with Blank Section, with ERV (75-105 Ton Rooftop Unit)

SIZE (TON) EFF	EXTENDED CHASSIS	SUPPLY FAN TYPE	FIELD USE FILTER SECTION	BLANK SECTION (ft)	2-PIECE UNIT	CONDENSER # OF V'S	A (in.)	B (in.)	D (in.)	F (in.)	G (in.)	H (in.)	J (in.)	K (in.)
75 All 90 STD EFF 105 STD EFF	No	STD	No	4	Yes	2	551.58	367.91	245.28	552.76	271.10	119.76	—	366.85
				8	Yes	2	599.83	416.16	245.28	601.00	271.01	119.76	—	415.10
		HIGH	No	4	Yes	2	566.67	383.00	245.28	567.85	286.10	119.76	—	381.94
				8	Yes	2	614.92	431.25	245.28	616.10	286.10	119.76	—	430.19
	Yes	STD	No	4	Yes	2	575.58	391.91	245.28	576.76	295.01	119.76	256.01	390.85
				8	Yes	2	623.83	440.16	245.28	625.00	295.01	119.76	256.01	439.10
		HIGH	No	4	Yes	2	590.67	407.00	245.28	591.85	310.10	119.76	256.01	405.94
				8	Yes	2	638.92	455.25	245.28	640.10	310.10	119.76	256.01	454.19
90 HI EFF 105 HI EFF	No	STD	No	4	Yes	3	603.58	367.91	245.28	604.76	271.01	171.76	—	366.85
				8	Yes	3	651.83	416.16	245.28	653.00	271.01	171.76	—	415.10
		HIGH	No	4	Yes	3	618.67	383.00	245.28	619.85	286.10	171.76	—	381.94
				8	Yes	3	666.92	431.25	245.28	668.10	286.10	171.76	—	430.19
	Yes	STD	No	4	Yes	3	627.58	391.91	245.28	628.76	295.01	171.76	256.01	390.85
				8	Yes	3	675.83	440.16	245.28	677.00	295.01	171.76	256.01	439.10
		HIGH	No	4	Yes	3	642.67	407.00	245.28	643.85	310.10	171.76	256.01	405.94
				8	Yes	3	690.90	455.25	245.28	692.10	310.10	171.76	256.01	454.19

50N 75-105 CONDENSER POSITION 6, OPTION 9 AND 10

UNIT SIZE	COND COILS 2V	COND COILS 3V	LOW SOUND 10B / 10D	DIM "S" (in.)
75 ALL	Yes	—	No	92.62
	Yes	—	Yes	98.06
90 STD EFF	Yes	—	No	92.62
	Yes	—	Yes	98.06
90 HI EFF	—	Yes	Yes	98.06
105 STD EFF	Yes	—	No	98.06
	Yes	—	Yes	98.06
105 HI EFF	—	Yes	Yes	98.06

**Fig. 21 — 50N Unit Sizes N, P, Q —
with Plenum, without Electric Heat, with Blank Section, with ERV (75-105 Ton Rooftop Unit) (cont)**

- NOTES:
1. DIMENSIONS ARE IN INCHES.
 2. UNIT WEIGHT AND CENTER OF GRAVITY INCLUDES ECONOMIZER, LARGEST INDOOR FAN MOTOR AND HIGH CAPACITY EVAPORATOR COIL.
 3. UNIT CLEARANCES:
 - ECONOMIZER AND INDOOR FAN: 10'-0"
 - CONDENSER AND FAN: 6'-0"
 - FOR SMALLER SERVICE AND OPERATIONAL CLEARANCES, CONTACT CARRIER APPLICATION ENGINEERING DEPARTMENT.
 - ALL ELECTRICAL CONNECTIONS TO BE MADE INSIDE OR OUTSIDE OF UNIT.
 4. WHEN UNIT IS SLAB MOUNTED ALLOW ADEQUATE HEIGHT FOR CONDENSATE DRAIN TRAP.
 5. ECONOMIZER SIDE HOODS ARE SHIPPED INSIDE OF UNIT.
 6. HEAT RECLAIM COIL DIMENSIONS (MAXIMUM):
 - LENGTH: 74.50"
 - WIDTH: 6.00"
 - HEIGHT: 74.50"
 - HEAT RECLAIM COIL FIELD SUPPLIED OR
 - ECONOMICIZER COILS ARE RECOMMENDATIONS ONLY.
 - ECONOMICIZER COILS ARE NOT FACTORY PROVIDED.
 - OPERATIONAL FACTORY SUPPLIED HOT WATER AND STEAM COILS ON UNITS WITHOUT ELECTRIC HEAT.
 - HOLES FOR COIL DIMENSIONS:
 - TUBE O. D.: 1 1/2" - ROWS 1, 2
 - TUBE O. D.: 1 1/2" - ROWS 3, 4
 - PIPE SIZE: 1 1/2" - NPT
 - STEAM COIL DIMENSIONS:
 - LENGTH: 110.00" - WIDTH: 5.00" - HEIGHT: 66.00"
 - PIPE SIZE: 2 1/2" - NPT
 - PIPE SIZE: 2 1/2" - NPT - ROWS 2
 7. ON UNITS EQUIPPED WITH FACTORY SUPPLIED POST FILTER OPTION, THE POST FILTERS ARE PASSED IN THE BLIND SECTION OF THE UNIT. THERE IS NO AVAILABLE SPACE BETWEEN THE POST FILTERS AND THE DISCHARGE OPENING.

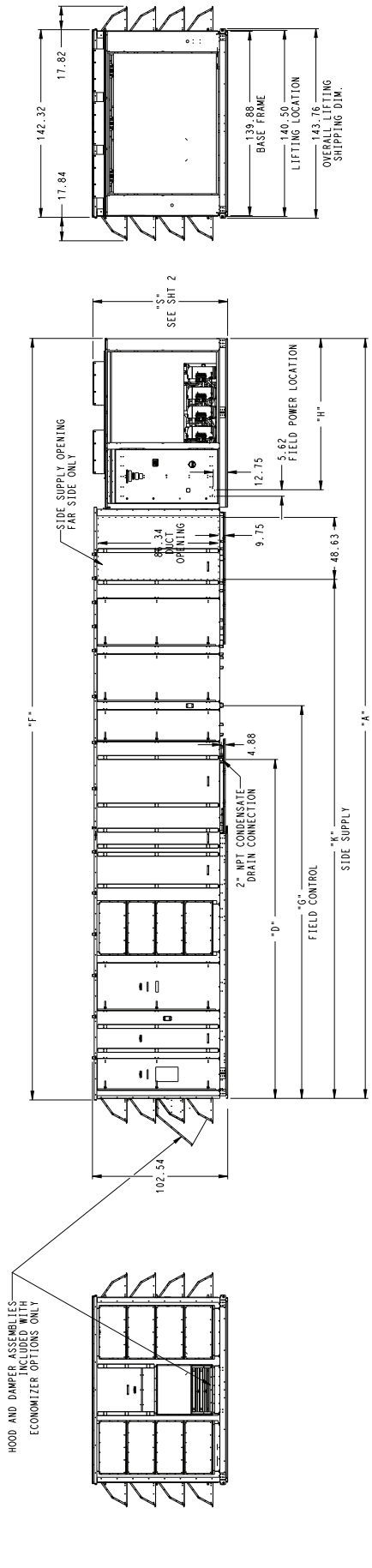
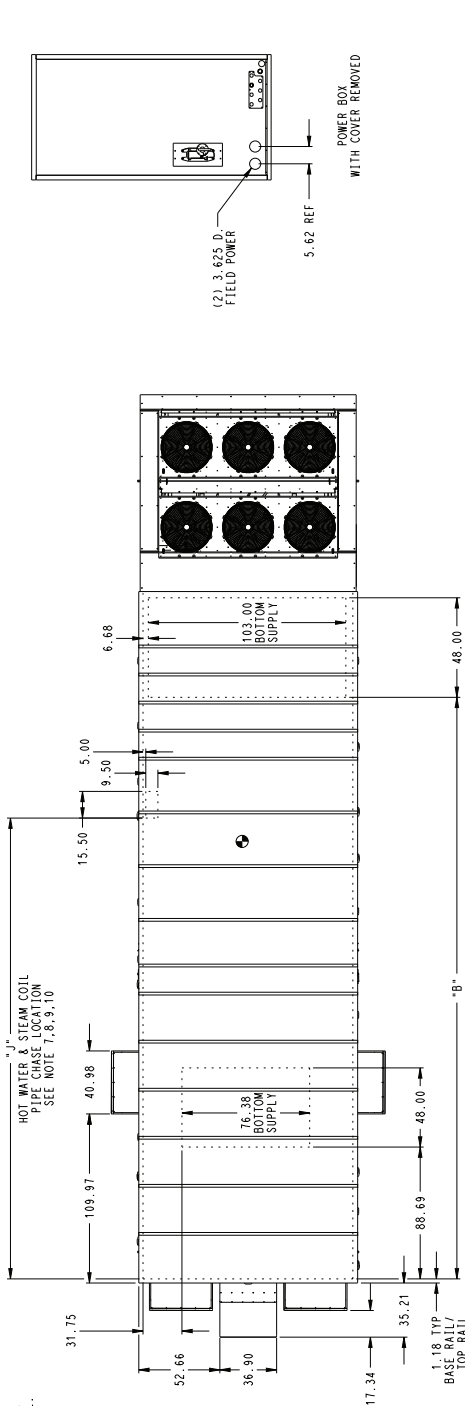

Fig. 22 — 50N Unit Sizes N, P, Q — with Plenum, without Electric Heat, with Blank Section, without ERV (75-105 Ton Rooftop Unit)

SIZE (TON) EFF	EXTENDED CHASSIS	SUPPLY FAN TYPE	FIELD USE FILTER SECTION	BLANK SECTION (ft)	2-PIECE UNIT	CONDENSER # OF V'S	A (in.)	B (in.)	D (in.)	F (in.)	G (in.)	H (in.)	J (in.)	K (in.)	
90-105 STD EFF	Yes	HIGH	No	8	No	2	568.70	385.01	177.02	569.94	241.84	119.76	185.75	383.95	
				4	No	3	533.36	297.67	177.02	534.60	202.75	171.76	—	296.61	
90 HI EFF 105 HI EFF	No	STD	No	8	No	3	581.61	345.92	177.02	582.85	202.75	171.76	—	344.86	
				4	No	3	593.86	358.17	237.52	595.10	263.25	171.76	—	357.11	
			8	Yes	3	660.36	424.67	255.77	661.60	281.50	171.76	—	423.61		
			4	No	3	548.45	312.76	177.02	549.69	217.84	171.76	—	311.70		
			8	No	3	596.70	361.01	177.02	597.94	217.84	171.76	—	359.95		
		4	Yes	3	627.20	391.51	255.77	628.44	296.59	171.76	—	390.45			
		8	Yes	3	675.45	439.76	255.77	676.69	296.59	171.76	—	438.70			
		HIGH	No	4	No	3	557.36	321.67	177.02	558.60	226.75	171.76	185.75	320.61	
				8	Yes	3	623.86	388.17	195.27	625.10	245.00	171.76	204.00	387.11	
			4	Yes	3	636.11	400.42	255.77	637.35	305.50	171.76	204.00	399.36		
	8		Yes	3	684.36	448.67	255.77	685.60	305.50	171.76	204.00	447.61			
	4		No	3	572.45	336.76	177.02	573.69	241.84	171.76	185.75	335.70			
	Yes	HIGH	No	8	Yes	3	638.95	403.26	195.27	640.19	260.09	171.76	204.00	402.20	
				4	Yes	3	651.20	415.51	255.77	652.44	320.59	171.76	204.00	414.45	
		8	Yes	3	699.45	463.76	255.77	700.69	320.59	171.76	204.00	462.70			
		STD	No	4	No	2	481.36	297.67	177.02	482.60	202.75	119.76	—	296.61	
				8	No	2	529.61	345.92	177.02	530.85	202.75	119.76	—	344.86	
	75 ALL 90 STD EFF 105 STD EFF	No	STD	Yes	4	No	2	541.86	358.17	237.52	543.10	263.25	119.76	—	357.11
					8	No	2	590.11	406.42	237.52	591.35	263.25	119.76	—	405.36
				4	No	2	496.45	312.76	177.02	497.69	217.84	119.76	—	311.70	
HIGH			No	8	No	2	544.70	361.01	177.02	545.94	217.84	119.76	—	359.95	
				4	No	2	556.95	373.26	237.52	558.19	278.34	119.76	—	372.20	
			8	Yes	2	623.45	439.76	255.77	624.69	296.59	119.76	—	438.70		
Yes			STD	No	4	No	2	505.36	321.67	177.02	506.60	226.75	119.76	185.75	320.61
					8	No	2	553.61	369.92	177.02	554.85	226.75	119.76	185.75	368.86
				4	No	2	565.86	382.17	237.52	567.10	287.25	119.76	185.75	381.11	
		8	Yes	2	632.36	448.67	255.77	633.60	305.50	119.76	204.00	447.61			
		HIGH	No	4	No	2	520.45	336.76	177.02	521.69	241.84	119.76	185.75	335.70	
				8	No	2	580.95	397.26	237.52	582.19	302.34	119.76	185.75	396.20	
			4	Yes	2	647.45	463.76	255.77	648.69	320.59	119.76	204.00	462.70		

50N 120-150 CONDENSER POSITION 6, OPTION 9 AND 10				
UNIT SIZE	COND COILS 2V	COND COILS 3V	LOW SOUND 10B / 10D	DIM "S" (in.)
75 ALL	Yes	—	No	92.62
	Yes	—	Yes	98.06
90 STD EFF	Yes	—	No	92.62
90 HI EFF	—	Yes	Yes	98.06
	Yes	—	Yes	98.06
105 STD EFF	Yes	—	No	98.06
	Yes	—	Yes	98.06
105 HI EFF	—	Yes	Yes	98.06

Fig. 22 — 50N Unit Sizes N, P, Q —
with Plenum, without Electric Heat, with Blank Section, without ERV (75-105 Ton Rooftop Unit) (cont)

Step 6 — Install Field-Fabricated Ductwork

⚠ WARNING

For vertical supply and return units, tools or parts could drop into ductwork and cause an injury. Install a 90-degree elbow in the supply and return ductwork between the unit and the conditioned space. If a 90-degree elbow cannot be installed, then a grille of sufficient strength and density should be installed to prevent objects from falling into the conditioned space. Failure to follow these instructions could result in personal injury or property damage due to falling objects.

Field-fabricated ductwork for vertical supply/vertical return units must be attached to the roof curb, or to the support steel, prior to the final rigging and installation of the unit. Supply and return duct dimensions are shown in Fig. 4.

To attach ductwork to roof curb, insert duct approximately 10 to 11 in. up into roof curb. Connect ductwork to 14-gage roof curb material with sheet metal screws driven from inside the duct.

Secure all ducts to the building structure, using flexible duct connectors between roof curbs and ducts as required. Ducts passing through an unconditioned space must be insulated and

covered with a vapor barrier. Outlet grilles must not lie directly below unit discharge.

Design supply duct strong enough to handle expected static pressures. Field-fabricated ductwork for horizontal supply/return units must be attached to the unit.

Step 7 — Rig Unit — Do not drop unit; keep upright. Use spreader bars over the unit to prevent sling or cable damage. Sheets of plywood placed along the condenser coils will provide additional protection. All lifting lugs **MUST** be used when lifting unit. Level by using unit frame as a reference. See Fig. 25-28 for information. Unit and accessory weights are shown in Tables 1 and 2. Weight distribution and center of gravity can be found in Fig. 29 and 30. Additional unit dimensional data can be found in Fig. 31.

Step 8 — Connect Condensate Drain — The drain is a 2-in. FPT pipe connection located on the right-hand side of the unit looking at the unit from the return air end. See Fig. 32 and 33. Figure 31 shows the additional length of units with an extended chassis.

With field-supplied fittings and pipe sections, plumb the primary condensate drain to the 2-in. FPT connector on the base rail. Use a trap height of at least 7 inches. See Fig. 32 and 33. Apply a bead of RTV or similar sealant around the pipe joint at the connector in the base rail.

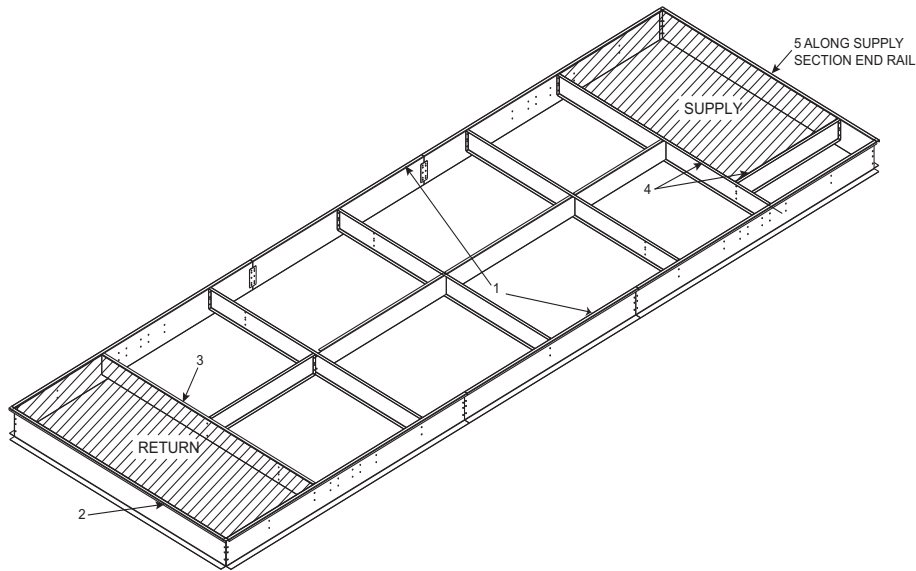

Fig. 23 — Gasket Location on Roof Curb

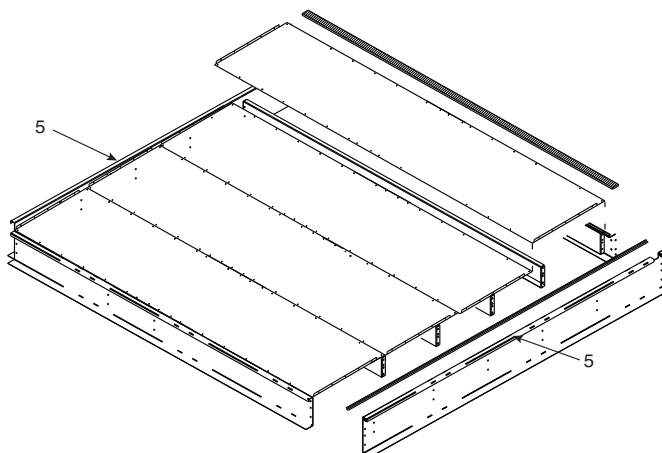

Fig. 24 — Gasket Location — Condenser Section Roof Curb



CAUTION - NOTICE TO RIGGERS:

ALL PANELS MUST BE IN PLACE WHEN RIGGING.

NOTE: 1. Rig with 10 cables and spread with 5 spreader bars of minimum length 3759 MM (148 Inch).
 2. Weights are for typical featured unit as listed below, Actual unit weight and lug location will vary based on options selected

UNIT TYPE	SIZE	TOTAL WEIGHT		CENTER OF GRAVITY				LIFTING LUG LOCATION										UNIT LENGTH	
				A		B		L1		L2		L3		L4		L5			
		LBS	KGS	IN	MM	IN	MM	IN	MM	IN	MM	IN	MM	IN	MM	IN	MM	IN	MM
50 Series Non-Split Econ, Bar Rel, Standard filters, High Cap Evap, High Efficiency, High Static Supply Fan w/ largest motor, High Static PE w/ largest motor, No Heat, No Post section, No Humidizer, No Split, No Field Filter Section	75	16927	7678	238.3	6058	67.2	1707	51.8	1316	144.8	3678	213.4	5420	299.9	7618	393.2	9987	443.8	11273
	90	18382	8338	269.4	6843	67.2	1707	103.8	2637	196.8	4999	265.4	6741	351.9	8938	445.2	11308	495.8	12593
	105	18873	8561	270.5	6871	67.2	1707	103.8	2637	196.8	4999	265.4	6741	351.9	8938	445.2	11308	495.8	12593
	120	22523	10226	271.9	6906	67.2	1707	103.8	2637	196.8	4999	265.4	6741	361.7	9187	455.0	11557	505.6	12842
	130	22871	10383	277.9	7059	67.2	1707	103.8	2637	196.8	4999	265.4	6741	361.7	9187	455.0	11557	505.6	12842
48 Series Non-Split Econ, Bar Rel, Standard filters, High Cap Evap, High Efficiency, High Static Supply Fan w/ largest motor, High Static Power Exhaust w/ Largest motor, Low gas heat, No Post section, No Extended chassis, No humidizer, No Split, No Field filter section	75	17864	8103	275.9	7008	67.2	1707	51.8	1316	201.5	5118	278.4	7071	364.9	9269	458.3	11641	508.8	12924
	90	19319	8763	308.1	7826	67.2	1707	103.8	2637	253.5	6439	330.4	8392	416.9	10589	509.3	12936	560.8	14244
	105	19810	8986	309.8	7869	67.2	1707	103.8	2637	253.5	6439	330.4	8392	416.9	10589	509.3	12936	560.8	14244
	120	23622	10724	309.7	7866	67.2	1707	103.8	2637	253.5	6439	330.4	8392	426.7	10838	519.3	13190	570.6	14493
	130	23970	10882	316.7	8044	67.2	1707	103.8	2637	253.5	6439	330.4	8392	426.7	10838	519.3	13190	570.6	14493
150	24263	11015	317.5	8065	67.2	1707	103.8	2637	253.5	6439	330.4	8392	426.7	10838	519.3	13190	570.6	14493	

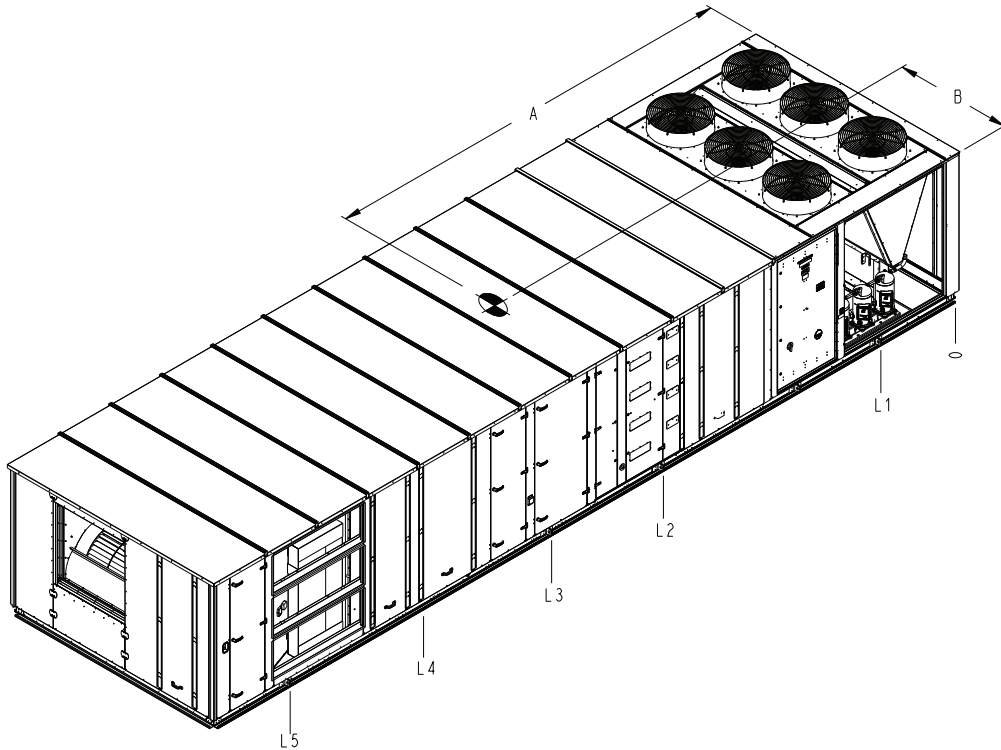

Fig. 25 — 50N 75-150 Ton Non-Split Rigging



CAUTION - NOTICE TO RIGGERS:

ALL PANELS MUST BE IN PLACE WHEN RIGGINIG.

NOTE: 1. Rig with 10 cables and spread with minimum 3759 MM [148 Inch] spreader bars.
 2. Weights are for typical featured unit as listed below. Actual unit weight and lug locations will vary based on options selected.

UNIT TYPE	SIZE	TOTAL WEIGHT		CENTER OF GRAVITY				LIFTING LUG LOCATION										UNIT LENGTH	
				A		B		L1		L2		L3		L4		L5			
		LBS	KGS	IN	MM	IN	MM	IN	MM	IN	MM	IN	MM	IN	MM	IN	MM	IN	MM
50 Series Split - Main Section	75	14529	6590	279	7087	67	1702	56	1422	149	3785	302.2	7676	370.9	9421	481.4	12228	494.9	12571
Econ, Bar Rel, Cartridge filters, Hi Cap Evap, High Efficiency, High Static Supply Fan w/ largest motor, Hi Static Return Fan w/ largest motor, High Electric Heat, 8' Blank section w/ post filters, Extended chassis w/ humidizer, Split, No Field filter section	90	15778	7157	310	7874	67	1702	108	2743	201	5105	354.2	8997	422.9	10742	533.4	13548	546.9	13891
	105	16269	7379	315	8001	67	1702	108	2743	201	5105	354.2	8997	422.9	10742	533.4	13548	546.9	13891
	120	19527	8865	310	7874	67	1702	108	2743	201	5105	354.2	8997	422.9	10742	543.2	13548	556.7	14140
	130	19875	9023	320	8128	67	1702	108	2743	201	5105	354.2	8997	422.9	10742	543.2	13548	556.7	14140
	150	20055	9105	320	8128	67	1702	108	2743	201	5105	354.2	8997	422.9	10742	543.2	13548	556.7	14140
48 Series Split - Main Section	75	15446	7006	285	7239	67	1702	56	1422	149	3785	302.25	7677	379.2	9632	489.6	12436	503.1	12779
Econ, Bar Rel, Cartridge filters, Hi Cap Evap, High Efficiency, High Static Supply Fan w/ largest motor, Hi Static Return Fan w/ largest motor, High gas heat, 8' Blank section w/ post filters, Extended chassis w/ humidizer, Split, No Field filter	90	16810	7625	318	8077	67	1702	108	2743	201	5105	354.2	8997	431	10947	541	13741	555.1	14100
	105	17301	7848	323	8204	67	1702	108	2743	201	5105	354.2	8997	431	10947	541	13741	555.1	14100
	120	20821	9453	326	8280	67	1702	108	2743	201	5105	366.2	9302	443.2	11257	563.5	14313	577	14656
	130	21169	9611	336	8534	67	1702	108	2743	201	5105	366.2	9302	443.2	11257	563.5	14313	577	14656
	150	21349	9693	335	8509	67	1702	108	2743	201	5105	366.2	9302	443.2	11257	563.5	14313	577	14656

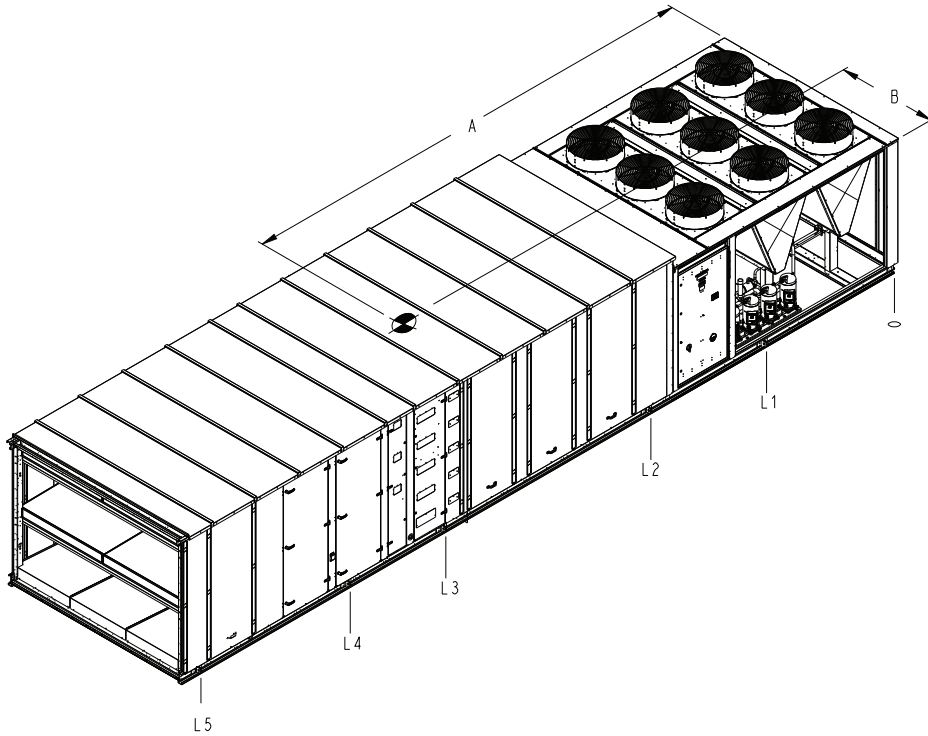

Fig. 26 — 50N 75-150 Ton Split (Main Unit) Rigging



CAUTION - NOTICE TO RIGGERS: ALL PANELS MUST BE IN PLACE WHEN RIGGINIG.

NOTE: 1. Rig with 4 cables and spread with two 3759 MM [148 Inch] spreader bars.
2. Weights are for typical featured unit as listed below, Actual unit weight will vary based on options selected

UNIT TYPE	SIZE	TOTAL WEIGHT		CENTER OF GRAVITY				LIFTING LUG LOCATION				UNIT LENGTH	
				A		B		L1		L2			
		LBS	KGS	IN	MM	IN	MM	IN	MM	IN	MM	IN	MM
50 Series Split - Return Section High Efficiency, High Static Supply Fan w/ largest motor, Hi Static Return Fan w/ largest motor, High Electric Heat, 8' Blank section w/ post filters, Extended chassis w/ humidimizer, Split, No Field filter section	75	5098	2315	76	1930	67	1702	5.4	137	98.2	2494	148.8	3780
	90	5451	2475	78	1981	67	1702	5.4	137	98.2	2494	148.8	3780
	105	5663	2571	78	1981	67	1702	5.4	137	98.2	2494	148.8	3780
	120	6150	2792	78	1981	67	1702	5.4	137	98.2	2494	148.8	3780
	130	6150	2792	78	1981	67	1702	5.4	137	98.2	2494	148.8	3780
	150	6305	2863	78	1981	67	1702	5.4	137	98.2	2494	148.8	3780
48 Series Split - Return Section Econ, Bar Rel, Cartridge filters, Hi Cap Evap, High Efficiency, High Static Supply Fan w/ largest motor, Hi Static Return Fan w/ largest motor, High gas heat, 8' Blank section w/ post filters, Extended chassis w/ humidimizer, Split, No Field filter	75	5098	2315	76	1930	67	1702	5.4	137	98.2	2494	148.8	3780
	90	5451	2475	78	1981	67	1702	5.4	137	98.2	2494	148.8	3780
	105	5663	2571	78	1981	67	1702	5.4	137	98.2	2494	148.8	3780
	120	6192	2811	78	1981	67	1702	5.4	137	98.2	2494	148.8	3780
	130	6192	2811	78	1981	67	1702	5.4	137	98.2	2494	148.8	3780
	150	6305	2863	78	1981	67	1702	5.4	137	98.2	2494	148.8	3780

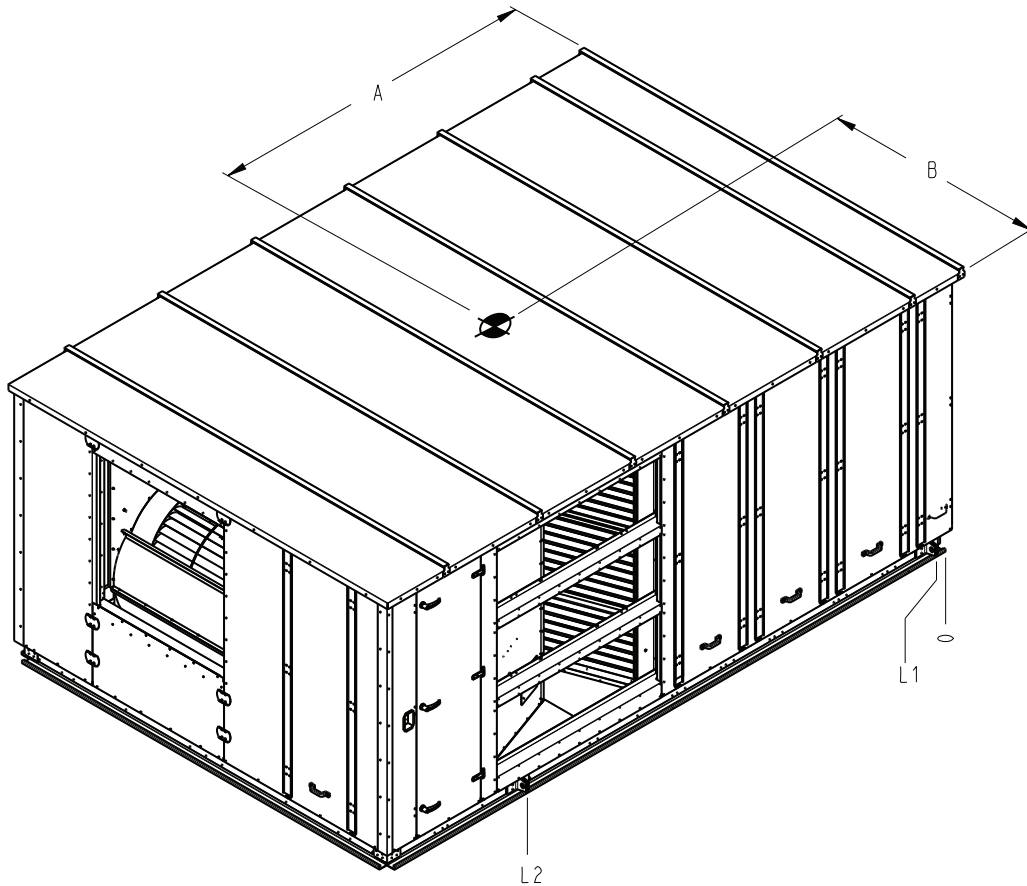

Fig. 27 — 50N 75-150 Ton Split (Return Section) Rigging



CAUTION - NOTICE TO RIGGERS: ALL PANELS MUST BE IN PLACE WHEN RIGGINIG.

NOTE: 1. Rig with 4 cables and spread with two 3759 MM [148 Inch] spreader bars.
2. Weights are for typical featured unit as listed below. Actual unit weight will vary based on options selected

UNIT TYPE	SIZE	TOTAL WEIGHT		CENTER OF GRAVITY				LIFTING LUG LOCATION				UNIT LENGTH	
				A		B		L1		L2			
		LBS	KGS	IN	MM	IN	MM	IN	MM	IN	MM	IN	MM
48/50 Series Split - ERV Return Section	75	9198	4172	110	2794	67	1702	5.4	137	185.8	4719	203.1	5159
	90	9280	4209	110	2794	67	1702	5.4	137	185.8	4719	203.1	5159
	105	9280	4209	110	2794	67	1702	5.4	137	185.8	4719	203.1	5159
Econ, Largest ERV, Filters, Largest Exhaust Fan and Motor, No Field Filter Section	120	10908	4948	111	2794	67	1702	5.4	137	185.8	4719	203.1	5159
	130	10908	4948	111	2794	67	1702	5.4	137	185.8	4719	203.1	5159
	150	10908	4948	111	2794	67	1702	5.4	137	185.8	4719	203.1	5159

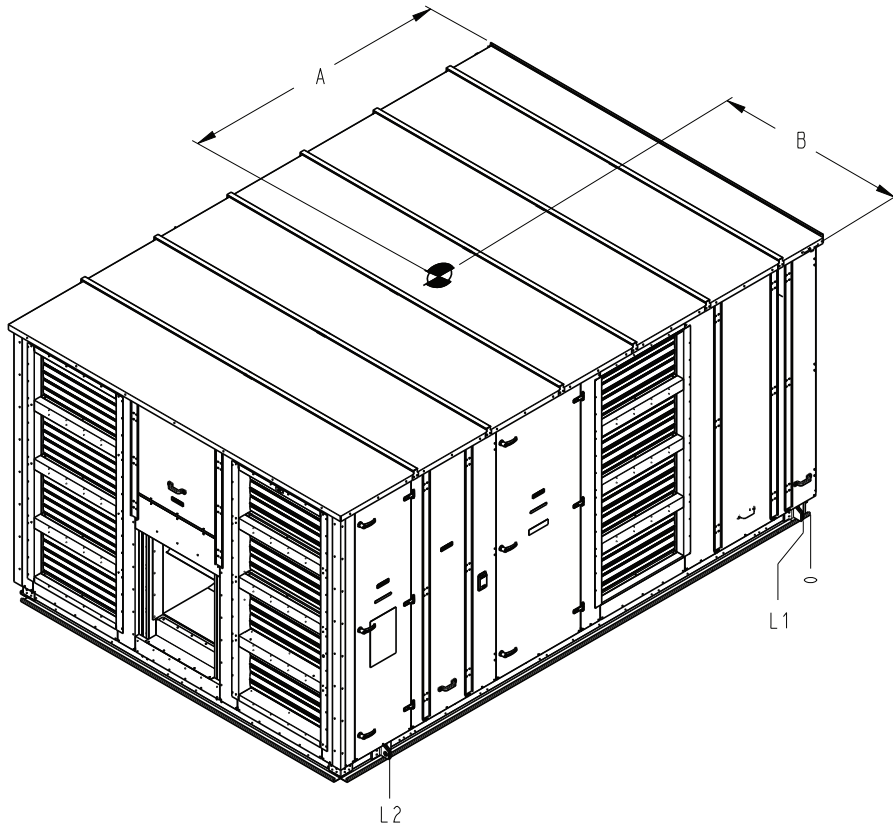

48NG502972 -

Fig. 28 — 48N 75-150 Ton Split (ERV Section) Rigging

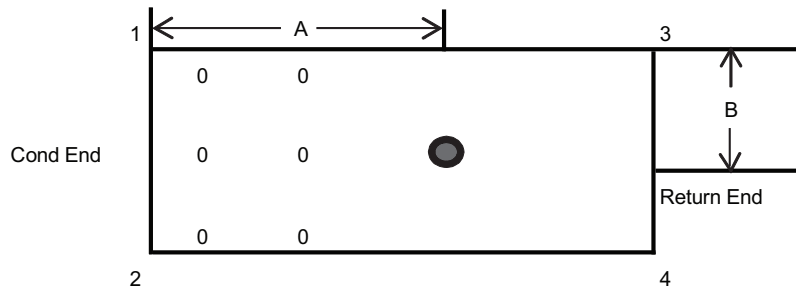

	NOMINAL CAPACITY (tons)	CORNER WEIGHTS (lb)				TOTAL (lb)	CENTER OF GRAVITY	
		1	2	3	4		A (in.)	B (in.)
50 Series Non-Split	75	3,958	3,880	4,590	4,500	16,927	238.3	67.2
	90	4,238	4,154	5,044	4,945	18,382	269.4	67.2
	105	4,330	4,245	5,200	5,098	18,873	270.5	67.2
	120	5,257	5,153	6,117	5,996	22,523	271.9	67.2
	130	5,201	5,099	6,348	6,223	22,871	277.9	67.2
	150	5,253	5,149	6,445	6,318	23,164	278.6	67.2
50 Series Split	75	4,453	4,365	5,458	5,351	19,627	352.1	67.2
	90	4,726	4,633	5,994	5,876	21,229	386.5	67.2
	105	4,811	4,716	6,264	6,141	21,932	391.0	67.2
	120	5,777	5,663	7,211	7,069	25,719	389.3	67.2
	130	5,693	5,580	7,471	7,323	26,067	397.9	67.2
	150	5,742	5,629	7,569	7,420	26,360	398.7	67.2

Fig. 29 — Weight Distribution and Center of Gravity

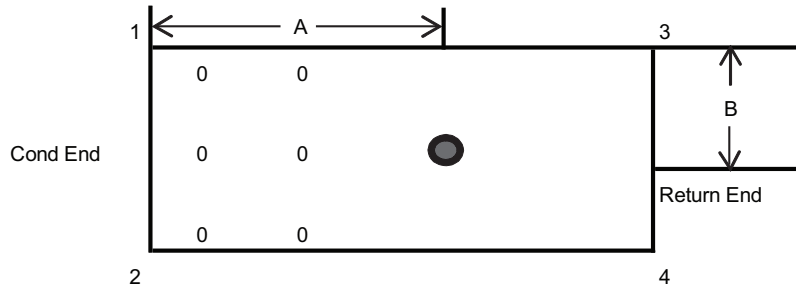

	SIZE	CORNER WEIGHTS (LB)				TOTAL (lb)	A (in.)	B (in.)	CORNER WEIGHT DISTRIBUTION (% OF TOTAL WTG)			
		1	2	3	4				1	2	3	4
50 Series Split ERV - Total Unit	75	5018	4919	7232	7089	24,257	408.1	67.2	21%	20%	30%	29%
	90	5260	5157	7661	7510	25,588	440.7	67.2	21%	20%	30%	29%
	105	5349	5243	7821	7667	26,079	441.4	67.2	21%	20%	30%	29%
	120	6376	6250	9273	9090	30,990	446.3	67.2	21%	20%	30%	29%
	130	6297	6173	9527	9339	31,338	453.4	67.2	20%	20%	30%	30%
	150	6343	6218	9573	9384	31,518	453.0	67.2	20%	20%	30%	30%

NOTES:

- Weights are for typical featured unit as listed.
- Actual unit weight and corner weight will vary based on options selected.
- 50 Series Split ERV - Total Unit: Econ, Bar Rel, Cartridge filters, Hi Cap Evap, High Efficiency, High Supply Fan with largest motor, Hi ERV with largest motor, High electric heat, 8 in. Blank section with post filters, Extended chassis with humidimizer, split, No Field filter section.
- Use the weight distribution to determine corner weight for specific unit configurations in ECAT. Use distribution based on unit size, PAC vs YAC and Split vs non-split. Do not show A and B dimensions.

Fig. 30 — Weight Distribution and Center of Gravity, ERV Units

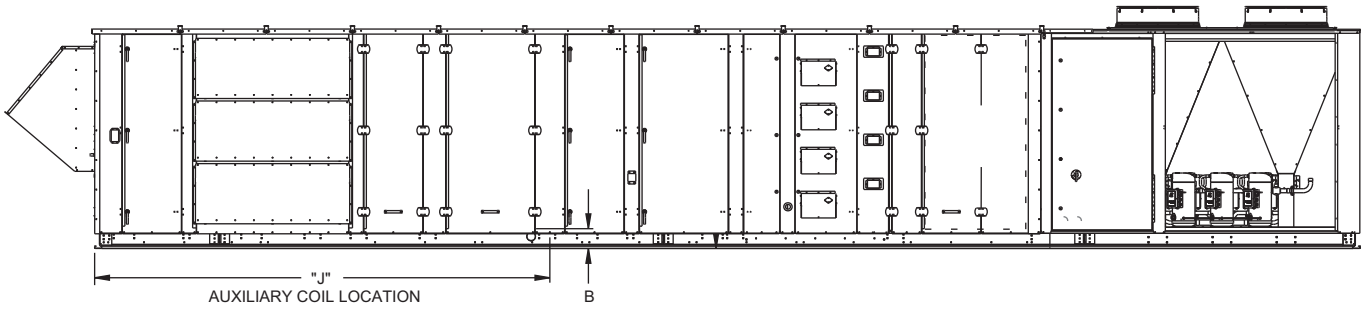

Auxiliary Coil Location — in.

UNIT SIZES 50N (TONS)	HEIGHT B	DISTANCE J
N, P, Q (75-105)	12.85	See dimension J on certified drawings, pages 26-48
R, S, T (120-150)	12.85	

Fig. 31 — Units with Optional Extended Chassis — Location of Coil Tracks

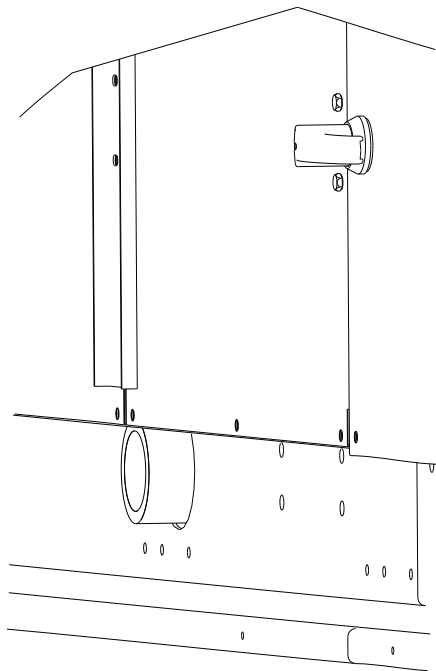
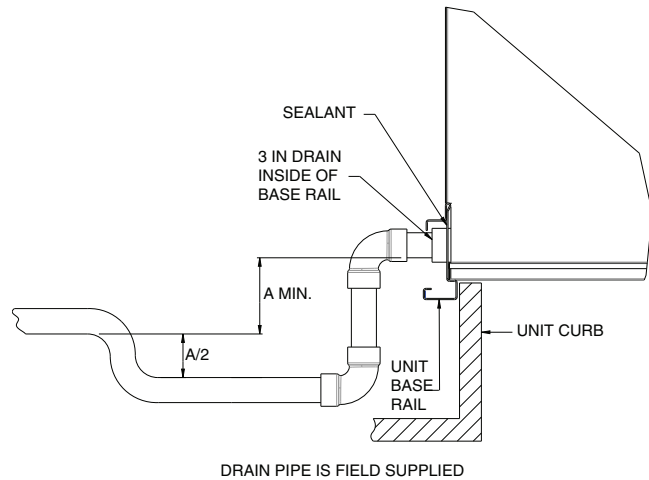

Fig. 32 — Condensate Drain Connection



A = 7-in. (178 mm) min

Fig. 33 — Condensate Drain Piping Details (Slab and Curb Mounted)

Step 9 — Install Outdoor Air Hoods — Units without ERV — Unit sizes 75 to 105 nominal tons have three hoods on both sides. Unit sizes 120 to 150 nominal tons have four hoods on both sides. Figures 11, 15, 17, 19, and 21 show units with three hoods. However, assembly of four hoods for the larger units is the same. Instructions for unpacking and assembly of hoods are below.

1. Remove the box from the unit (see Fig. 34).
 - a. Shipping support straps are bolted to the unit. Remove four bolts on each, and discard straps.
 - b. Remove the hood supports (quantity 2 or 3) (see Fig. 35).
 - c. Remove packaging from the unit.
 - d. Reinstall hood supports (Fig. 35).

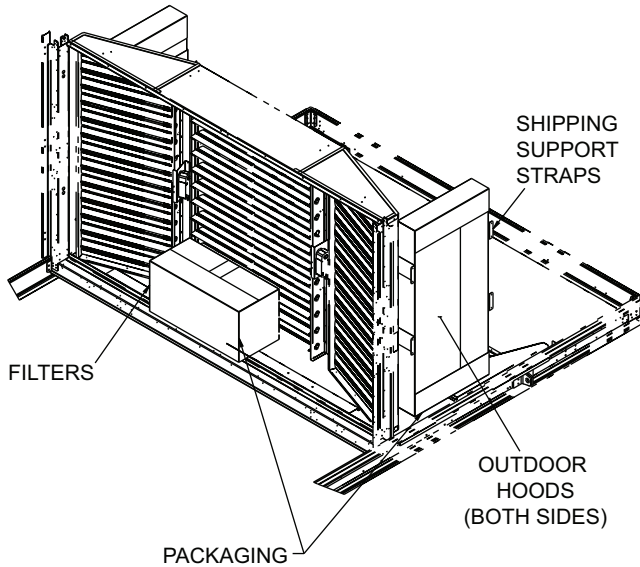

Fig. 34 — Packaging Locations

2. Remove filters located between return/exhaust fan and economizer dampers, these are packaged separately from hoods for shipping (see Fig. 34). Screws, other hardware and seal strips are packaged with the outdoor hoods (Fig. 34).
3. Apply seal strip to the unit. Strip should extend around entire openings (see Fig. 36).
4. Assemble hoods (see Fig. 37).
 - a. Attach hood sides (Items 1 and 2) to the hood top (Item 3). Fasten hood using six screws on each side.
 - b. Attach hood support (Item 4) to hood top (Item 3).
 - c. Attach angle (Item 5) to hood sides (two per hood). Fasten angle to the hood side using three screws per side.
 - d. Attach hood support (Item 7) to top (Item 3) using six screws.
 - e. Attach clips (Item 8) to hood support (Item 7).
 - f. Attach angle (Item 10) to hood support (Item 7) using eight screws.
 - g. Attach angle (Item 9) to angle (Item 10) using two pop rivets.
 - h. Place RTV or similar sealant on all of the 6 corners to prevent water leaks.
 - i. Install hood assembly to unit using four screws on each side and nine screws on the top.
 - j. Install filters (Item 6) to hood assembly.
5. Repeat Step 4 for each hood.

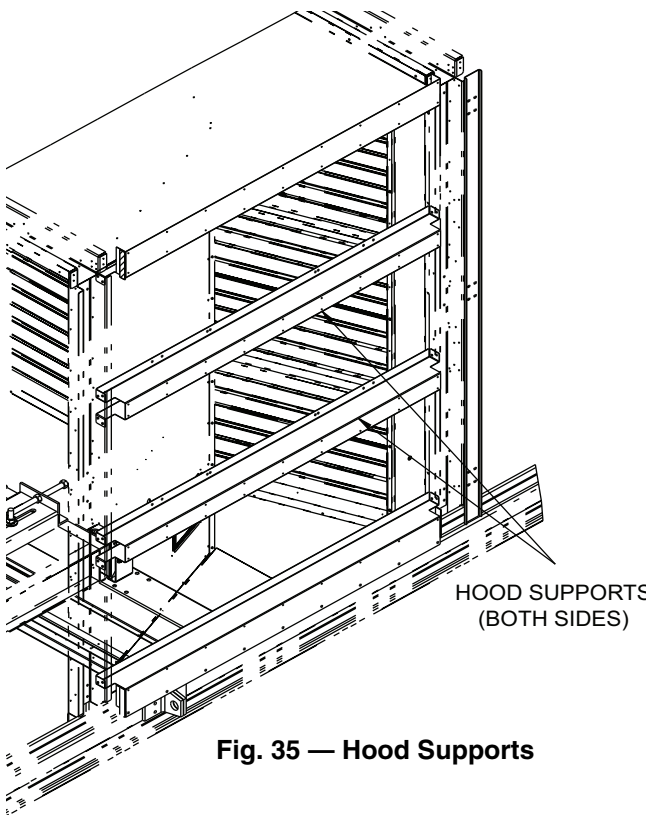

Fig. 35 — Hood Supports

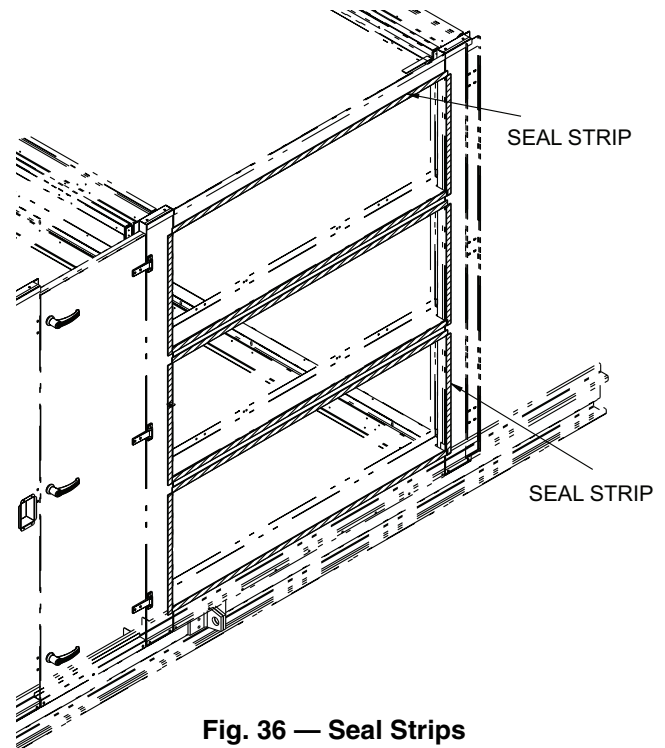

Fig. 36 — Seal Strips

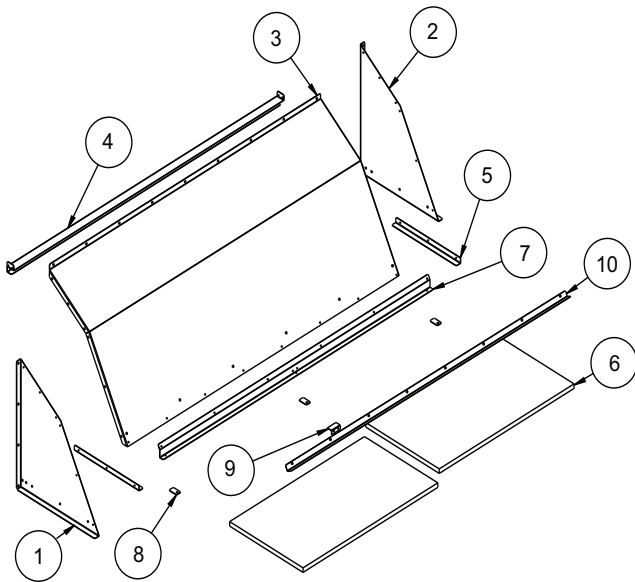

Fig. 37 — Hood Assembly

Step 10 — Install Hoods — Units with ERV

INSTALL EXHAUST HOODS — UNITS WITH ERV — For shipping, exhaust air hood and damper are packaged in boxes and located inside the unit.

1. Remove boxes from unit. See Fig. 38 for locations.
2. Assemble hood. See Fig. 39.
 - a. Attach damper supports Items 3-6, to hood sides, Item 1 and 2.
 - b. Attach damper, Item 11, to damper supports
 - c. Attach hood front, Item 7, to hood sides.
 - d. Attach hood top, Item 8, to hood sides and front.
 - e. Apply seal strip to perimeter of hood, top, sides and bottom that mate up to unit.
 - f. Attach hood to end of unit. See Fig. 40.

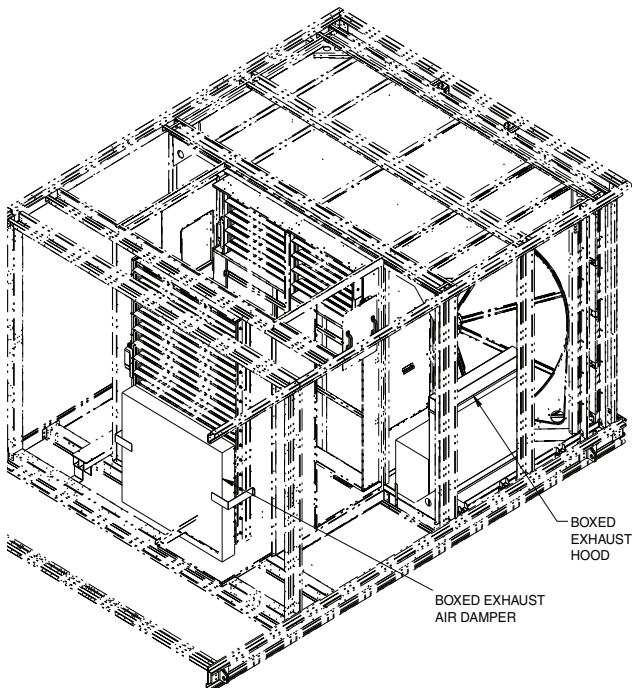

Fig. 38 — Packaging Location for Exhaust Hood and Exhaust Air Damper

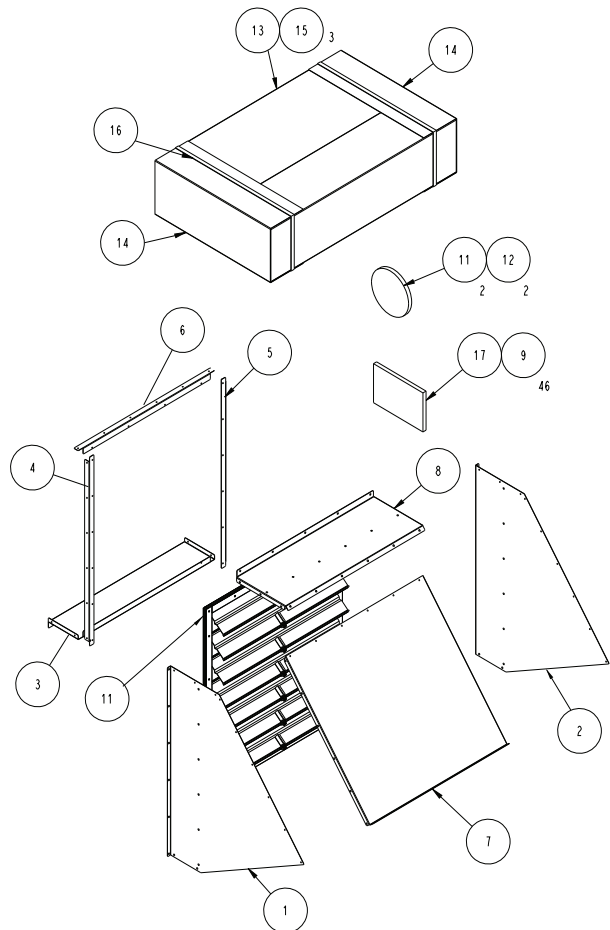

Fig. 39 — Exhaust Hood Assembly and Parts Detail

INSTALL OUTDOOR AIR INTAKE HOODS — OPTIONAL ERV UNITS — The 75-105 ton units will have 3 hoods attached to each intake damper on the end of the unit. The 120-150 ton units will have 4 hoods on each damper. Assembly and attachment of all hoods is the same. For shipping, the outdoor air intake hoods and filters are packaged in boxes located inside the unit.

1. Remove boxes from unit. See Fig. 41 for location.
2. Apply seal strip to the unit around the damper openings. See Fig. 36.
3. Assemble hoods. See Fig. 42.
 - a. Attach hood sides, Items 1 and 2, to the hood top, Item 3. Fasten using 6 screws on each side.
 - b. Attach hood support, Item 4 to hood top, Item 3.
 - c. Attach angle, Item 5 to hood side (2 per hood). Fasten angle to the hood side using three screws per side.
 - d. Attach hood support, Item 7, to hood top, Item 3 using 6 screws.
 - e. Attach clips, Item 8 to hood support, Item 7.
 - f. Attach angle, Item 10, to hood support, Item 7, using 8 screws.
 - g. Place RTV or similar sealant on all of the 6 corners to prevent water leaks.
 - h. Repeat Step 3 for all hoods.
4. On the hood to be installed second from the bottom on the right hand damper, install the humidity sensor and bracket, Items 15 and 19.

5. Install the hood with the humidity sensor second from the bottom on the right hand damper. See Fig. 42. Route the wire harness attached to the damper to the humidity sensor and attach the wires to the sensor terminals per the markings on the harness
6. Install remaining hoods on unit. See Fig 40 for location.
7. Install filters, Item 6, to each hood assembly.

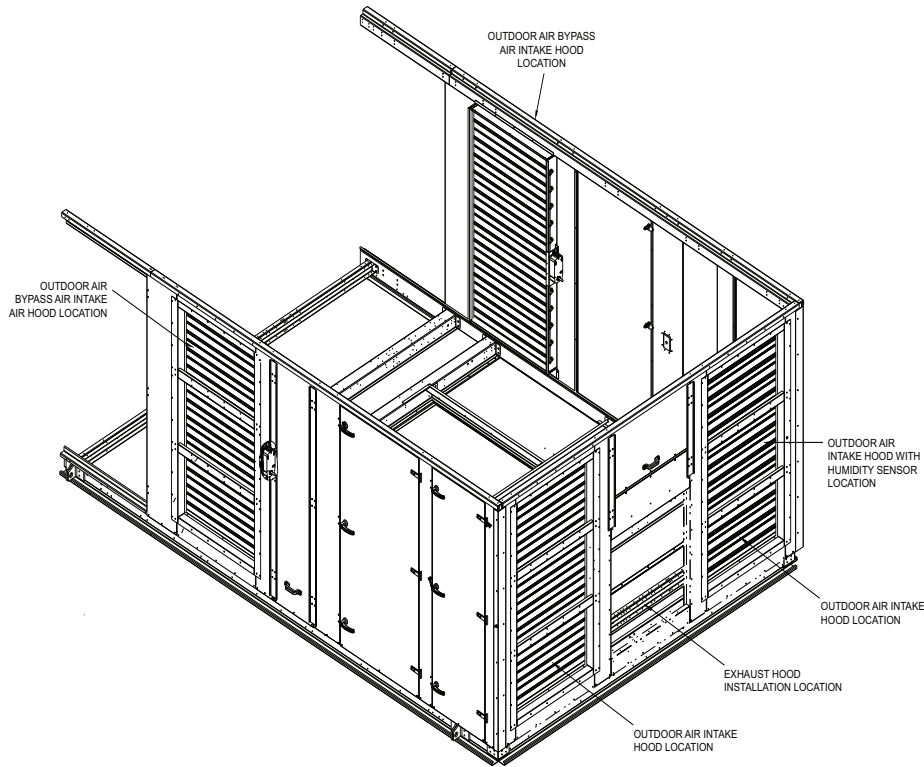

Fig. 40 — ERV Hood Locations

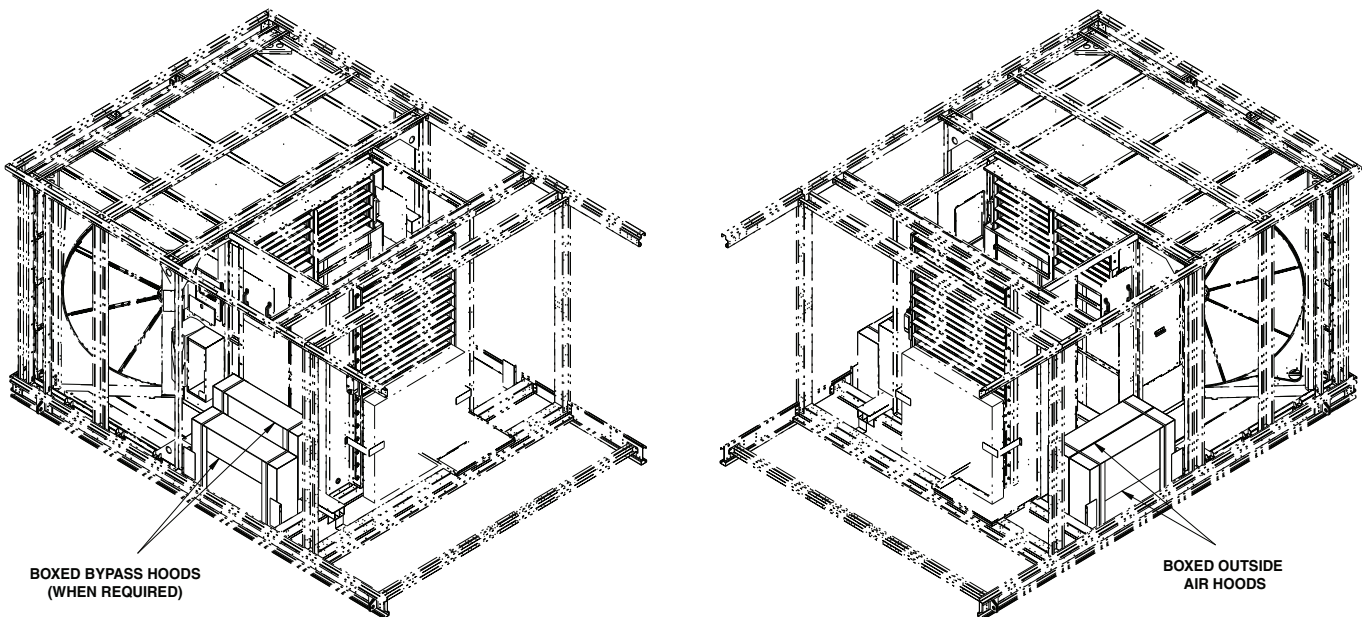

Fig. 41 — Boxed Packaging: Bypass Hoods (Left); Outside Air Hoods (Right)

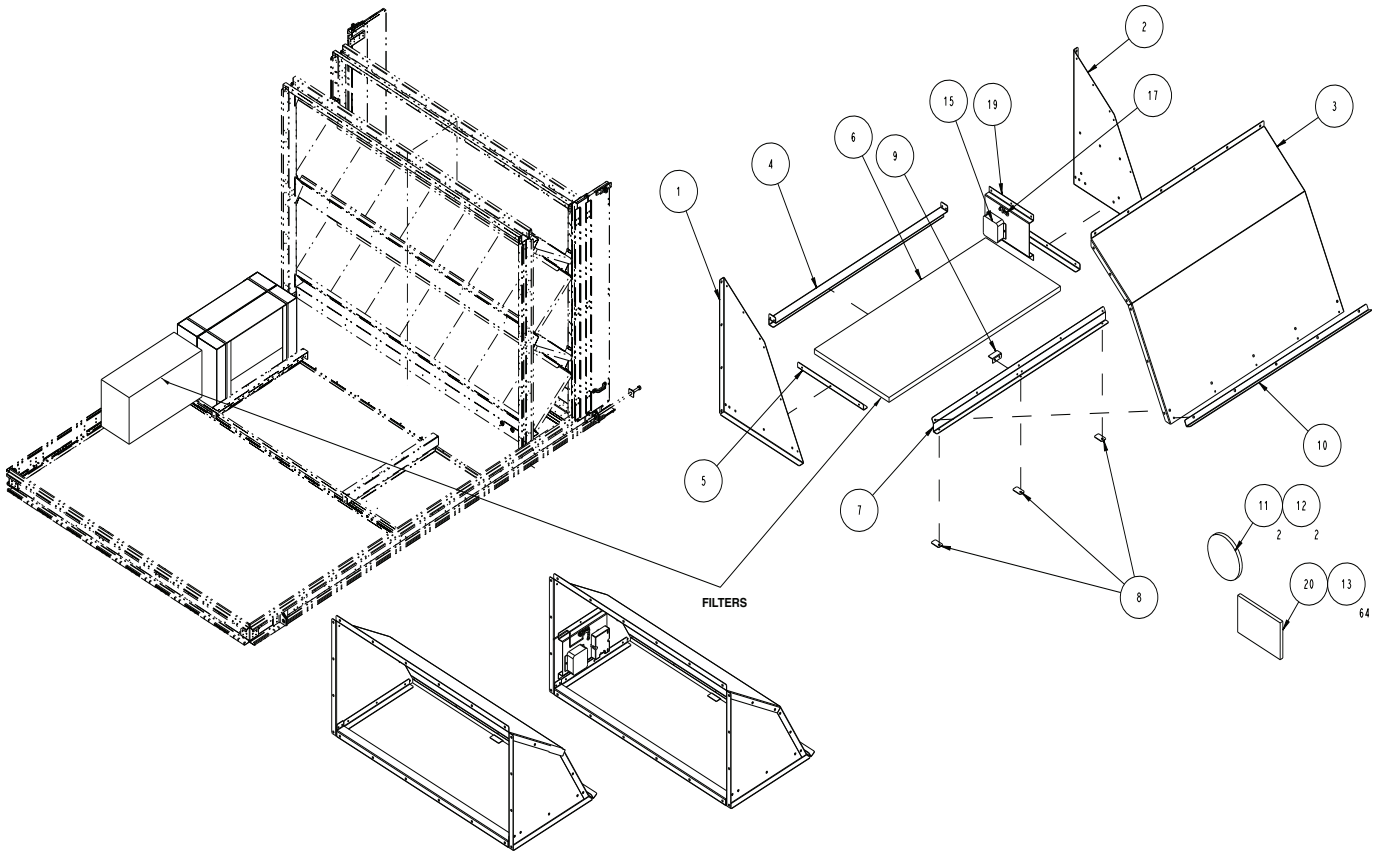

Fig. 42 — Hood Parts Detail; Filter Packaging Location

INSTALL OUTDOOR AIR BYPASS AIR INTAKE HOODS — ERV UNITS WITH OPTIONAL OUTDOOR AIR INTAKE BYPASS — Unit sizes 75-105 tons will have 3 hoods attached to each intake damper on the side of the unit.

The 120-150 ton units will have 4 hoods on each damper. Assembly and attachment of all hoods is the same. For shipping, the outdoor air intake bypass hoods and filters are packaged in boxes located inside the unit.

1. Remove boxes from unit. See Fig. 41.
2. Apply seal strip to the unit around the damper openings. See Fig. 36.
3. Assembly and installation of the hoods is the same as describe under Install Outdoor Air Intake Hoods - Optional ERV Units Steps 3, 6, and 7.
4. Install hoods on unit. See Fig. 40 for location.

Step 11 — Route Field Wiring — Field power wiring is brought into the unit through the back of the power box near the bottom. Wiring can be brought through the roof curb through field-supplied watertight connections. See Fig. 46.

There are two 3⁵/₈-in. holes for field power wiring in the power box and a 7⁷/₈-in. hole in the side post for 24-v control wiring provided. Field-supplied couplings must be used when routing wiring into the control box.

See Fig. 43 for recommended disconnect location.

Step 12 — Make Field Electrical Connections

IMPORTANT: All units have variable frequency drives (VFD) factory installed. VFDs generate, use, and can radiate radio frequency energy. If units are not installed and used in accordance with these instructions, they may cause radio interference. They have been tested and found to comply with limits of a Class A computing device pursuant to International Standard EN 61000-2/3, which are designed to provide reasonable protection against such interference when operated in a commercial environment.

POWER WIRING — Units are factory-wired for the voltage shown on the unit nameplate. The main terminal block is suitable for use with copper wires only. Maximum wire size varies according to disconnect size.

DISCONNECT SIZE	QUANTITY...MAXIMUM WIRE SIZE (MCM)
250 Amps	1...300
400 Amps	1...600
600 Amps	2...600

NOTE: Conduit used for filed wiring must be sealed at the unit end of the conduit. Failure to do so could cause the conduit to act as a chimney in cold climates causing warm building air to condense in the power box.

Units without Factory-Installed Disconnect — When installing units, provide a disconnect per NEC (National Electrical Code) of adequate size (MOCP [maximum overcurrent protection] of unit is on the informative plate). All field wiring must comply with NEC and all local codes. Size wire based on MCA (minimum circuit amps) on the unit informative plate. See Fig. 44 for power wiring connections to the unit power terminal block and equipment ground. Maximum wire size is two (2) 500 MCM (maximum wire size) conductors per pole.

CAUTION

Use care when drilling into corner post to avoid damage to condenser coil.

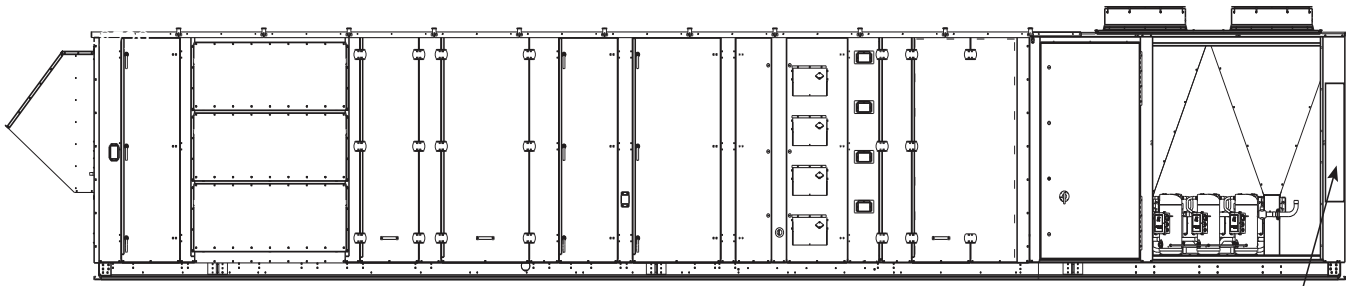

RECOMMENDED
FIELD-SUPPLIED
DISCONNECT
LOCATION

Fig. 43 — Disconnect Location

Units with Factory-Installed Disconnect — The factory-installed disconnect is an interlocking, door-type. The disconnect handle locks the door when it is in the ON position. The disconnect handle must be in the OFF position to open the control box door. The disconnect is located in the control box behind the control box door for all units. See Fig. 43.

All field wiring must comply with NEC and all local codes. Wire must be sized based on MCA (minimum circuit amps) on the unit informative plate. See Fig. 43-46 for power wiring connections to the unit disconnect and equipment ground.

Operating Voltage — Operating voltage to the unit must be within the voltage range indicated on the unit nameplate. Voltages between phases must be balanced within 2%, and the current must be balanced within 10%. See Table 8 for motor limits.

Use the following formula to determine the percentage of voltage imbalance.

Voltage Imbalance

$$= 100 \times \frac{\text{max voltage deviation from average voltage}}{\text{average voltage}}$$

Example: Supply voltage is 460-3-60.

AB = 452 v

BC = 464 v

AC = 455 v

$$\begin{aligned} \text{Average Voltage} &= \frac{452 + 464 + 455}{3} \\ &= \frac{1371}{3} \\ &= 457 \end{aligned}$$

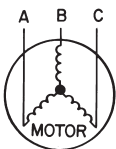

Determine maximum deviation from average voltage:

(AB) 457 – 452 = 5 v

(BC) 464 – 457 = 7 v

(AC) 457 – 455 = 2 v

Maximum deviation is 7 v.

Determine percent voltage imbalance:

$$\begin{aligned} \% \text{ Voltage Imbalance} &= 100 \times \frac{7}{457} \\ &= 1.53\% \end{aligned}$$

This amount of phase imbalance is satisfactory as it is below the maximum allowable 2%.

IMPORTANT: If the supply voltage phase imbalance is more than 2%, contact local utility immediately.

Unit failure as a result of operation on improper line voltage or excessive phase imbalance constitutes abuse and may cause damage to electrical components.

Determine percent voltage imbalance:

$$\begin{aligned} \% \text{ Voltage Imbalance} &= 100 \times \frac{7}{457} \\ &= 1.53\% \end{aligned}$$

This amount of phase imbalance is satisfactory as it is below the maximum allowable 2%.

IMPORTANT: If the supply voltage phase imbalance is more than 2%, contact local utility immediately.

Unit failure as a result of operation on improper line voltage or excessive phase imbalance constitutes abuse and may cause damage to electrical components.

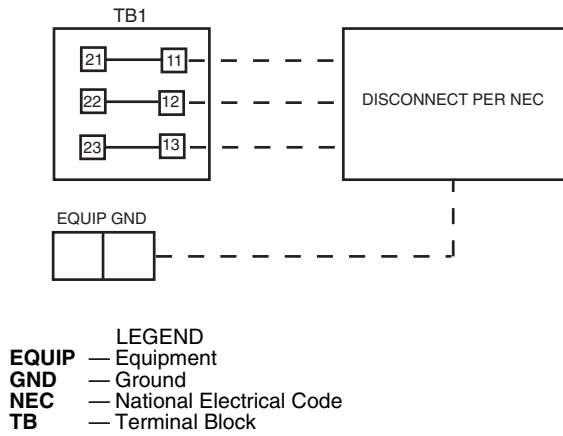

Fig. 44 — Field Power Wiring Connections

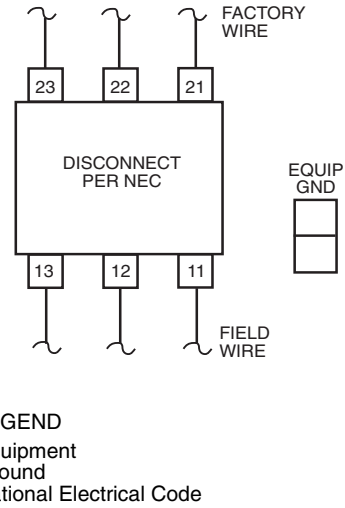

Fig. 46 — Field Power Wiring Connections for Factory-Installed Disconnect

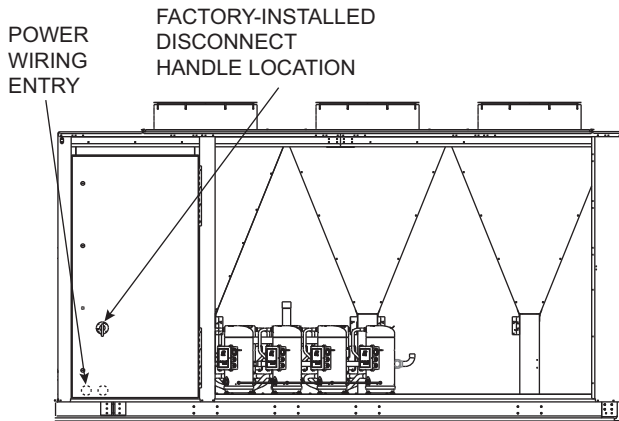

Fig. 45 — Factory-Installed Disconnect Location (End of Unit Shown)

Table 8 — Motor Limits

NOMINAL HP	BkW	MAX BHP	MAX BkW	MAX AMPS (EA)		RATED EFFICIENCY
				460 V	575 V	
7.5	5.60	8.6	6.39	12.0	10.0	91.7
10	7.46	11.5	8.56	14.3	12.0	91.7
15	11.19	17.3	12.89	22.0	19.0	93.0
20	14.92	22.9	17.10	28.7	23.0	93.6
25	18.65	28.7	21.41	36.3	28.4	93.6
30	22.38	34.5	25.71	41.7	36.3	94.1
40	29.84	45.9	34.27	55.0	43.8	94.1
50	37.30	57.4	42.83	71.0	52.8	94.5
60	44.80	68.9	51.41	83.0	60.5	95.0
75	59.50	86.1	64.25	101.0	80.5	95.0
100	74.60	114.8	85.67	132.0	106.0	95.4

LEGEND
Bhp — Brake Horsepower
BkW — Brake Kilowatts

NOTE: Extensive motor and electrical testing on the Carrier units has ensured that the full horsepower range of the motor can be utilized with confidence. Using fan motors up to the horsepower ratings shown in the Motor Limitations table will not result in nuisance tripping or premature motor failure. Unit warranty will not be affected.

Step 13 — Connect Air Pressure Tubing — Before options such as the variable frequency drive (VFD) and/or modulating power exhaust can operate properly, the pneumatic tubing for pressure sensing must be installed. Use fire-retardant plenum tubing (field-supplied). All control devices use 1/4-in. tubing. Tubing must be run from the appropriate sensing location (in the duct or in the building space) to the control device location in the unit.

VARIABLE FREQUENCY DRIVE — The tubing for the duct pressure (DP) control option should sample supply duct pressure approximately 2/3 of the way out from the unit in the main trunk duct, at a location where a constant duct pressure is desired.

On these units, the duct pressure is sensed by a pressure transducer. The pressure transducer output is directed to the unit control module. On all sizes, the DP transducer is located in the unit control box. See Fig. 47 and 48 for control box details. Use a nominal 1/4-in. plastic tubing.

Refer to appropriate base unit Controls, Start-Up, Operation, Service, and Troubleshooting manual for instructions on adjusting set points for duct pressure controls.

POWER EXHAUST — The tubing for the building pressure (BP) control (achieved via the modulating power exhaust option) should sample building pressure in the area near the entrance lobby (or other appropriate and sensitive location) so that location is controlled as closely to design pressures as possible.

These units use a pressure transducer for sensing building pressure. The BP transducer is located in the unit control box. Use a nominal 1/4-in. plastic tubing.

For instructions on adjusting BP control set points, refer to the Controls, Start-Up, Operation, Service, and Troubleshooting manual.

RETURN FAN — The tubing for the building pressure (BP) control (achieved via the return fan exhaust option) should sample building pressure in the area near the entrance lobby (or other appropriate and sensitive location) so that location is controlled as closely to design pressures as possible.

The units use a pressure transducer for sensing building pressure. The BP transducer is located in the unit control box. Use a nominal 1/4-in. plastic tubing. For instructions on adjusting BP control set points, refer to the Controls, Start-Up, Operation, Service, and Troubleshooting manual.

Step 14 — Remove Supply-Fan Shipping Bracket Screws — Supply-fan shipping bracket screws must be removed from each corner of the fan sled before starting unit. See Fig. 49.

1. To remove shipping bracket screws, raise fan sled by turning adjusting bolt counterclockwise until spring is compressed slightly.
2. Remove screws holding shipping bracket to spring support.

NOTE: It is not necessary to remove the shipping bracket, only remove the screws.

3. After removing all shipping bracket screws, level fan sled using the adjusting screws.

Step 15 — Remove Optional Power Exhaust Shipping Bracket Screws — Optional power exhaust shipping bracket screws must be removed from each corner of the fan sled before starting unit.

1. To remove shipping bracket screws, raise fan sled by turning adjusting bolt counterclockwise until spring is compressed slightly.
2. Remove screws holding shipping bracket to spring support.
NOTE: It is not necessary to remove the shipping bracket, only remove the screws.
3. After removing all shipping bracket screws, level fan sled using the adjusting screws.

Step 16 — Remove Optional Return-Fan Shipping Brackets — Optional return fan shipping brackets must be removed from each corner of the fan sled before starting unit. See Fig. 50.

To remove shipping brackets, remove 2 screws holding each bracket to the cross rail. There are 4 brackets per unit.

After removing all shipping brackets, level the fan using the adjustment screws.

Step 17 — Remove Optional ERV Fan Shipping Bracket — Optional ERV power exhaust fan shipping brackets must be removed from each corner of the fan sled before starting unit. In order to access the fan shipping brackets, several sections of each ERV wheel must be removed. The following instructions are for removing the brackets on the unit control box side of the unit. Repeat the instructions to remove the brackets on the side opposite the unit control box.

1. Open the access door to the ERV section. See Fig. 51.
2. Next remove one of the ERV wheel segments. Wheel segments are held in place by a segment retainer, which pivots on the wheel rim and is held in place by a segment retaining catch. In addition, there is a single screw at the wheel hub. See Fig. 52.
3. Unlock two segment retainers and segment retaining catches, one on each side of the segment to be removed.
4. Remove the retaining screw wheel hub of the segment.
5. Pull out the segment holding it by the 2 outer corners.
6. Repeat the process to remove a second segment next to the one already removed.

NOTE: Block the wheel from rotating using a brace/ clamp etc. as the wheel will rotate due to the imbalance caused by the removed sections.

7. Crawl through the wheel to gain access to the shipping bracket access panel. See Fig. 53.
8. Remove shipping bracket access panel.
9. Remove the (2) shipping brackets by removing the (2) screws on each bracket. See Fig. 54.
10. Replace shipping bracket access panel
11. Replace wheel segments by performing Steps 2 through 5 in reverse for each wheel segment.
12. Repeat the process on the opposite side of the unit.

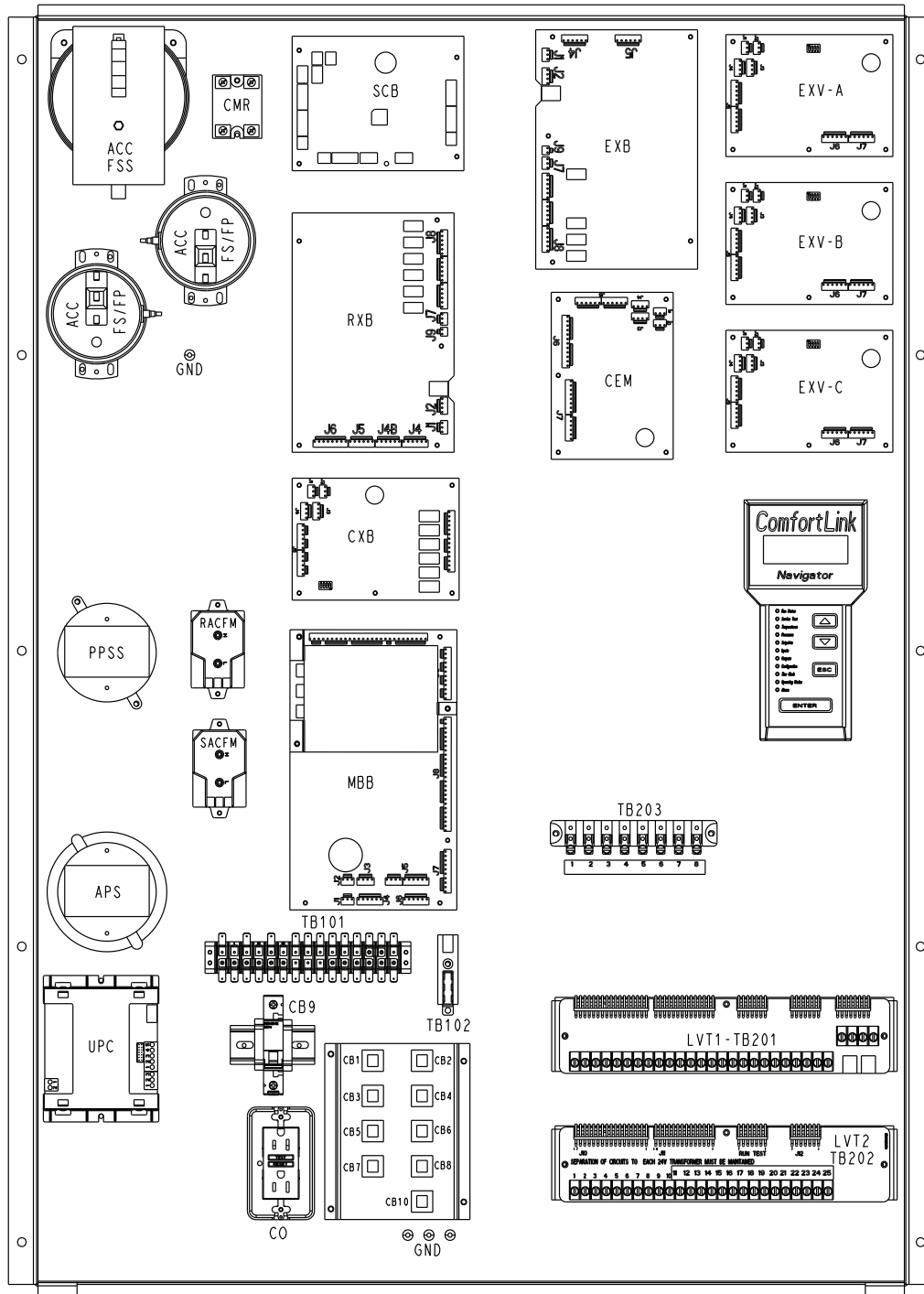

LEGEND

- ACC** — Accessory
- ACC FSS** — Accessory Fan Status Switch
- APS** — Air Pressure Switch
- CB** — Circuit Breaker
- CEM** — Controls Expansion Module
- CMR** — Compressor Modulation Relay
- CO** — Convenience Outlet
- CXB** — Compressor Expansion Board
- EXB** — Economizer Control Board
- EXV** — Expansion Valve Control Board
- FS/FP** — Filter Switch/filter Pressure

- GND** — Ground
- LVT** — Low Volume Terminal
- MBB** — Main Base Board
- PPSS** — Plenum Pressure Safety Switch
- RACFM** — Return Air CFM
- RXB** — Rooftop Control Board
- SACFM** — Supply Air CFM
- SCB** — Staged Gas Control Board
- TB** — Terminal Block
- UPC** — Unitary Protocol Converter

Fig. 47 — Control Box Component Arrangement

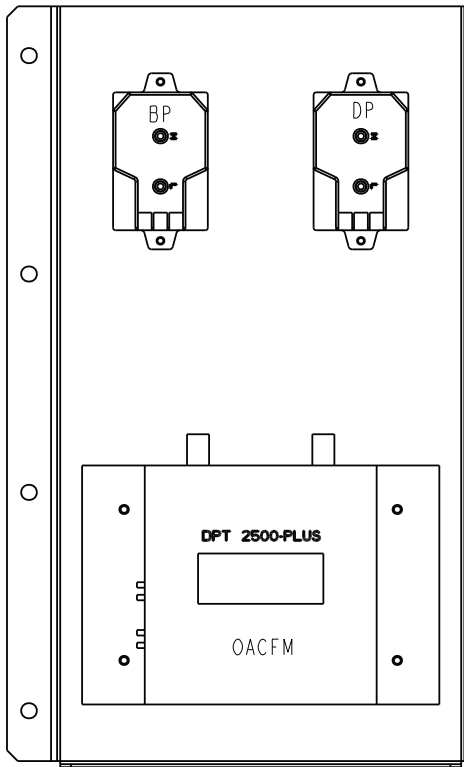

LEGEND
BP — Building Pressure
DP — Duct pressure
OACFM — Outdoor air CFM

Fig. 48 — Auxiliary Control Box Arrangement

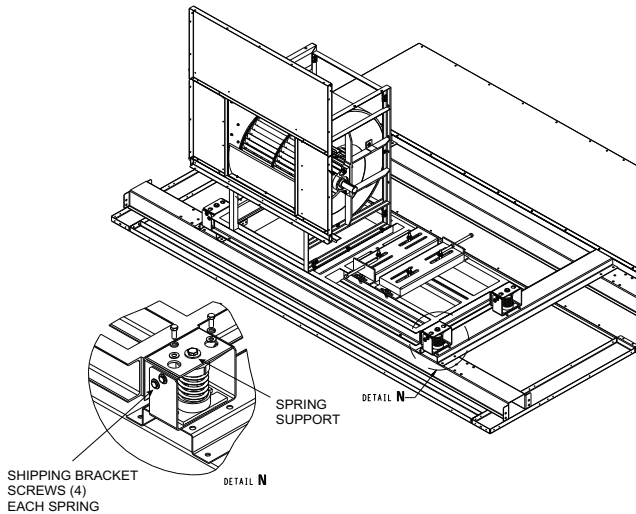

Fig. 49 — Supply Fan and Power Exhaust Fan Shipping Bracket Bolts

Step 18 — Remove Optional Return-Fan Shipping Brackets — Optional return fan shipping brackets must be removed from each corner of the fan sled before starting unit. See Fig. 50.

To remove shipping brackets, remove 2 screws holding each bracket to the cross rail. There are 4 brackets per unit.

After removing all shipping brackets, level the fan using the adjustment screws.

Step 19 — Install Supply-Air Thermistors — Supply-air thermistors are a field-installed, factory-provided component. Three supply-air thermistors are shipped with electric heat units equipped with optional SCR controlled electric heat inside the unit control box. Thermistor wires must be connected to the SCB (Staged Gas Control Board) in the unit control box. See Table 9. The supply-air thermistors should be located in the supply duct with the following criteria:

- downstream of the heater elements
- equally spaced as far as possible from the heater elements
- a duct location where none of the supply-air thermistors are within sight of the heater elements
- a duct location with good mixed supply air

Step 20 — Install Unit Accessories — For applications requiring accessories, the following packages are available:

All units:

- space temperature sensor
- CO₂ sensor
- space temperature sensor with CO₂ sensor
- airflow switch
- filter switch
- smoke detector

Refer to the individual accessory installation instructions in each accessory package for information on installing accessories.

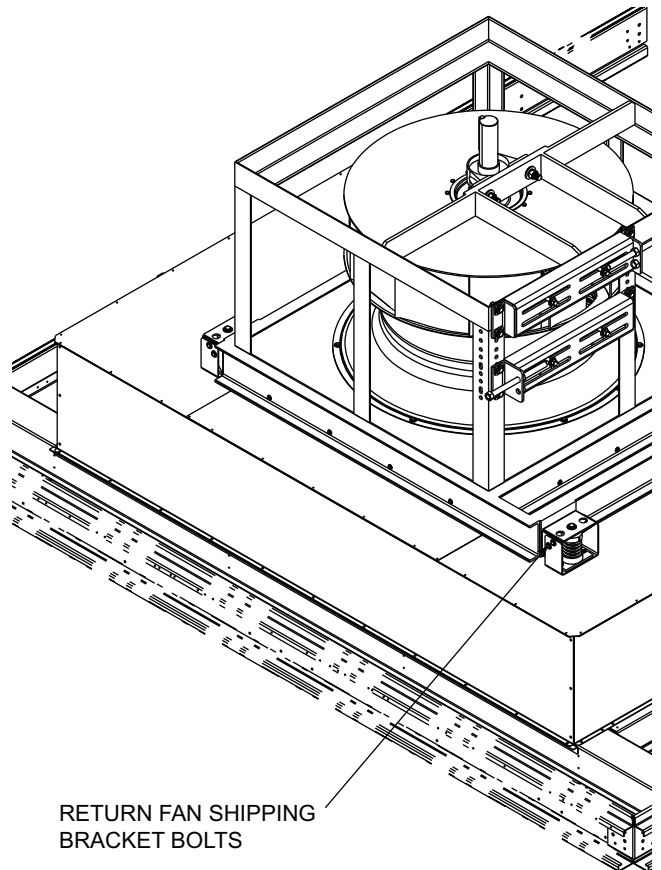
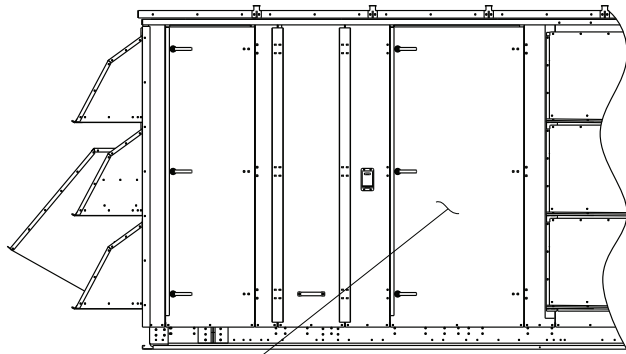

Fig. 50 — Return Fan Shipping Bracket Bolts



ERV SECTION
ACCESS DOOR

Fig. 51 — ERV Section Access Door

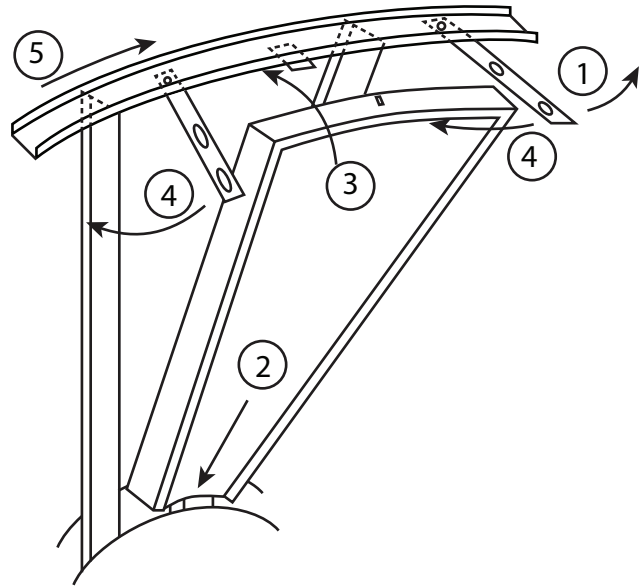
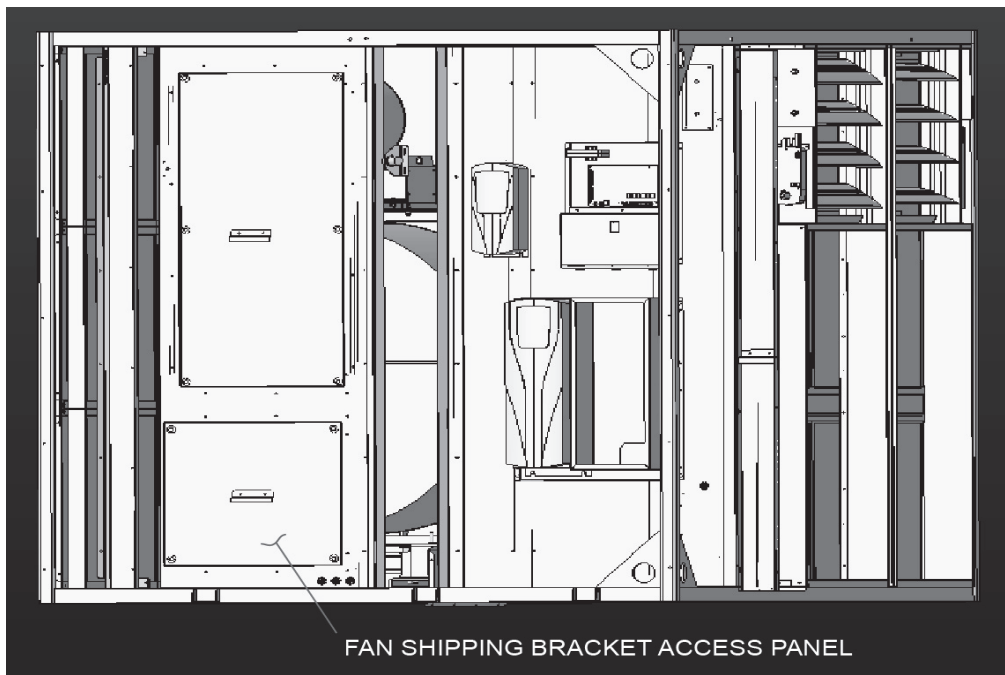
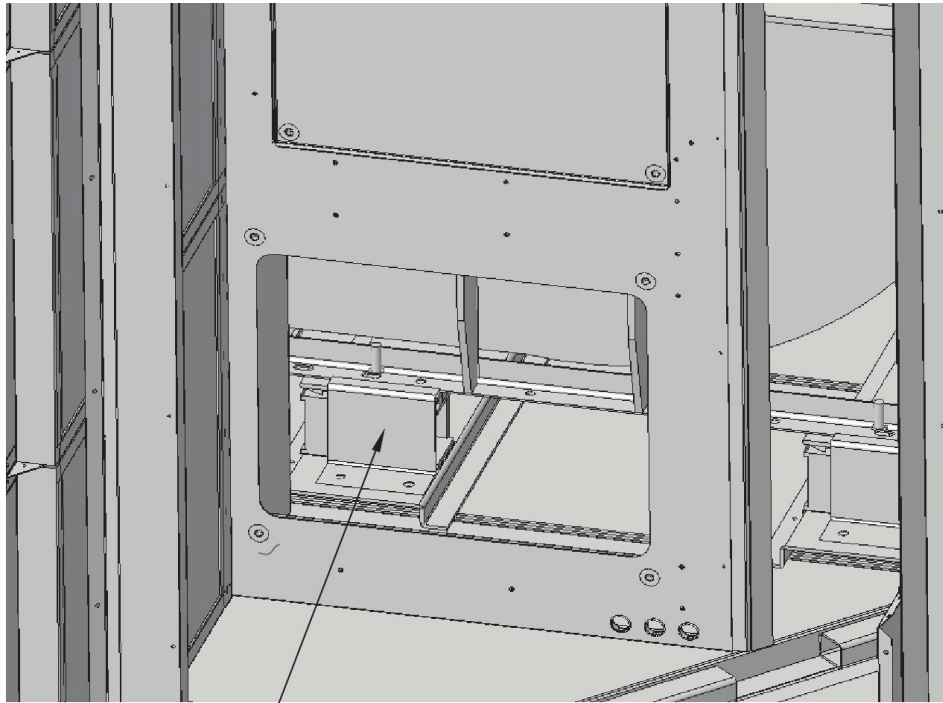

Fig. 52 — Segment Installation



FAN SHIPPING BRACKET ACCESS PANEL

Fig. 53 — Fan Shipping Bracket Access Panel



FAN SHIPPING BRACKET ACCESS PANEL

Fig. 54 — Fan Shipping Bracket

Table 9 — SCB Thermistor Designations

THERMISTOR	PIN CONNECTION POINT	FUNCTION AND LOCATION	PART NO.
		Thermistors	
SAT1	J8 – 1,2 (SCB)	Supply-Air Thermistor (SAT) — Inserted into supply section underneath the heat section (factory-provided, field-installed)	HH79NZ034
SAT2	J8 – 3,4 (SCB)	Supply-Air Thermistor (SAT) — Inserted into supply section underneath the heat section (factory-provided, field-installed)	
SAT3	J8 – 5,6 (SCB)	Supply-Air Thermistor (SAT) — Inserted into supply section underneath the heat section (factory-provided, field-installed)	

Wheel Air Seal Adjustment — Diameter seals are provided on each wheel cassette to minimize transfer of air between the counter flowing airstreams. Follow below instructions if adjustment is needed.

1. Loosen diameter seal adjusting screws and back seals away from the wheel surface. See Fig. 55.
2. Rotate the wheel clockwise until two opposing spokes are hidden behind the bearing support beam.
3. Using a folded piece of paper as a feeler gauge, position the paper between the seal and wheel surface.
4. Adjust the seal towards wheel surface until a slight friction on the feeder gauge (paper) is detected while moving the gauge along the length of the spoke.
5. Re-tighten adjustment screws and re-check clearance with the feeder gauge.

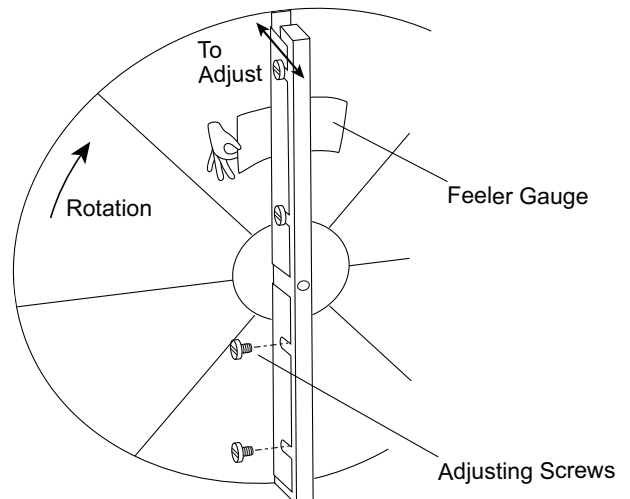

Fig. 55 —Diameter Seal Adjustment

Two-Piece Unit Fit Up

1. Locate and remove split parts package from return section of unit. Open package and remove split unit parts. See Tables 10 and 11 for parts list.
2. Rig main unit section and return section separately.
3. Do not assemble main unit section and return section on ground and attempt to lift. Unit pieces must be assembled on roof curb.
4. Insert base rail guides into the base rails of the main unit section. Do not attach with screws yet. See Fig. 56 and 57.
5. Insert top rail guides into top rails of the main unit section. Do not attach with screws yet. See Fig. 56 and 58.
6. Rig and set the main unit section on the unit roof curb. Align the unit bulkhead with the supply opening in the roof curb.
7. Remove the roof cap, top cover and L brackets from the filter end of the return section. Save these parts for later installation. See Fig. 59 and 60.
8. Rig and set return section onto the roof curb using rail guides as an alignment aid. The return section must be within 2 in. of the main unit section. Slide base rail and top rail guides from main unit section rails partially into return section rails.
9. Install tar tape on edge of main unit base rails to seal base rail splice. See Fig. 61.
10. Using 3/4-in. x 30-in. threaded rod, nuts, washers and backing plates provided, pull and secure the base rails together. See Fig. 62.

11. Attach (4) brackets to top rails. Using 3/8-in. x 6-in. threaded rods, nuts, washers and backing plates provided, pull the top rails together and secure with top rail guide from Step 5. See Fig. 63. Remove threaded rods and brackets after securing top rail guide.
12. Place seal strip along both sides of basepan joint. Attach basepan covers to basepan joint. See Fig. 64.
13. Install L brackets, top cover and top cap joining main unit section and return section top cover assemblies. See Fig. 65 and 66.
14. Connect control wiring plugs located at unit split. All same color plugs should be connected together.

On units equipped with return air fan or power exhaust fan option, locate black, yellow, and blue power wires located at the split in main section. Run the wires through the grommet below the return air filters and through the grommet at the economizer damper. See Fig. 67. Run wires through wire trays, separate from control wires, to the return fan/power exhaust fan VFD on back wall of return section. Connect wires to VFD power terminal connections: Black to UL1, Yellow to V1, and Blue to W1. On units equipped with VFD bypass option connect the wires to the power distribution in the VFD bypass box: Black to L1, Yellow to L2, and Blue to L3. See Fig. 68.

Connect air pressure tubes located at split. All same numbered tubes should be connected together. See Table 12 for tubes associated with unit options.

15. Install side post on far side of unit. See Fig. 69.
16. Install side panels at main unit section/return section split. Install panel side brackets, 2 on each panel. See Fig. 69.

Table 10 — 75-105 Nominal Ton Units Parts List

ITEM	COMPONENT NUMBER	QUANTITY	COMPONENT NAME	COMPONENT QUALIFIER
1	48NG501939	2	RAIL,MOUNTING	SPLIT,BASE,GUIDE
2	48NG501935	2	ROD,THREADED	3/4-10 UNC 2A 30-in. L
3	48NG501937	8	WASHER,PLATE	3/4-in. LRT SPLIT
4	AU02AB361	4	WASHER,FLAT	3/4
5	AT11AB361	6	NUT,HEAVY HEX	3/4-10
6	48NG501938	4	BRACKET,TIE	LRT SPLIT TOP
7	AL48AM307	12	SCREW,HEXHD SR	1/4 X 5/8
8	48NG501936	2	ROD,THREADED	3/8-16 UNC 2A 6" L
9	AU02AB242	4	WASHER,FLAT	3/8
10	AT39AB241	4	NUT,HEX	3/8-16
11	48NG501940	1	PLATE,COVER	SPLIT,BASEPAN
12	48NG501941	1	PLATE,COVER	SPLIT,BASEPAN
15	AL31AY308	34	SCREW	
16	AL79AU216	2	SCREW,HEXHD TF	#10 X 1/2
17	48NG401017	1	POST ASSY,SIDE	6-in. (75-105 T)
18	48NG401072	2	PANEL ASSY,SIDE	12-in. (75-105 T)
19	48NG501897	3	BRACKET,PANEL	SKIN JOINT 75-105T
21	AA06BS168	40	BOLT,HEXHD	1/4 X 0.75
28	AL56ZA003	42	SCREW	1/4 AB-14 X 5/8-in. SERR.
31	99SR120216142001	2	SEAL STRIP	
33	48NG501629	2	PLATE	JOIN SPLIT UNITS
40	PF0144	3	SEALER,PRESTITE	2-in. WIDE ROLL

Table 11 — 120-150 Nominal Ton Units Parts List

ITEM	COMPONENT NUMBER	QUANTITY	COMPONENT NAME	COMPONENT QUALIFIER
1	48NG501939	2	RAIL, MOUNTING	SPLIT,BASE,GUIDE
2	48NG501935	2	ROD, THREADED	³ / ₄ -10 UNC 2A 30-in. L
3	48NG501937	8	WASHER, PLATE	³ / ₄ -in. LRT SPLIT
4	AU02AB361	4	WASHER, FLAT	³ / ₄
5	AT11AB361	6	NUT, HEAVY HEX	³ / ₄ -10
6	48NG501938	4	BRACKET, TIE	LRT SPLIT TOP
7	AL48AM307	12	SCREW, HEXHD SR	¹ / ₄ X ⁵ / ₈
8	48NG501936	2	ROD, THREADED	³ / ₈ -16 UNC 2A 6-in. L
9	AU02AB242	4	WASHER, FLAT	³ / ₈
10	AT39AB241	4	NUT, HEX	³ / ₈ -16
11	48NG501940	1	PLATE, COVER	SPLIT,BASEPAN
12	48NG501941	1	PLATE, COVER	SPLIT,BASEPAN
15	AL31AY308	34	SCREW	
16	AL79AU216	2	SCREW, HEXHD TF	#10 X ¹ / ₂
17	48NG401018	1	POST ASSY, SIDE	6-in. (120-150 T)
18	48NG401070	2	PANEL ASSY, SIDE	12-in. (120-150 T)
19	48NG501896	3	BRACKET, PANEL	SKIN JOINT 120-150T
20	48NG500998	2	HANDLE	
21	AA06BS168	40	BOLT, HEXHD	¹ / ₄ X 0.75
38	AL56ZA003	42	SCREW	¹ / ₄ AB-14 X ⁵ / ₈ -in. SERR.
33	48NG501629	2	PLATE	JOIN SPLIT UNITS
40	PF0144	3	SEALER, PRESTITE	2-in. WIDE ROLL

Table 12 — Air Pressure Tube Connections

OPTION	CONTROL	TUBE NUMBER
Return Air Fan	RACFM Control PPSS	4, 5 and 6
Power Exhaust Fan with CFM Sensor	EACFM Control	5 and 6
Outdoor Air CFM	OACFM Control	7 and 8

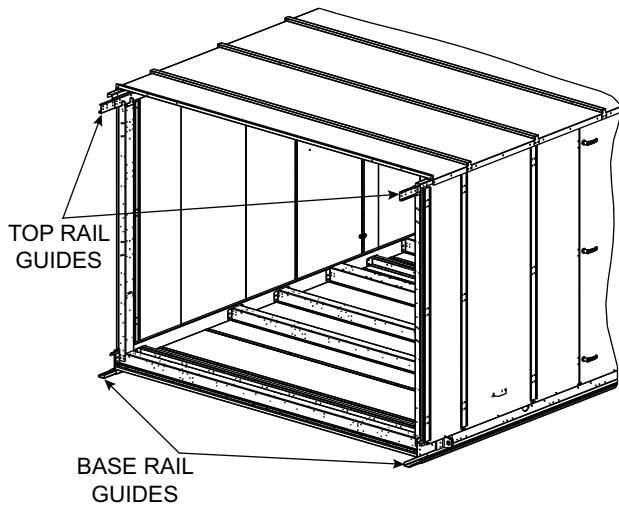

Fig. 56 — Base and Top Rail Guide Locations

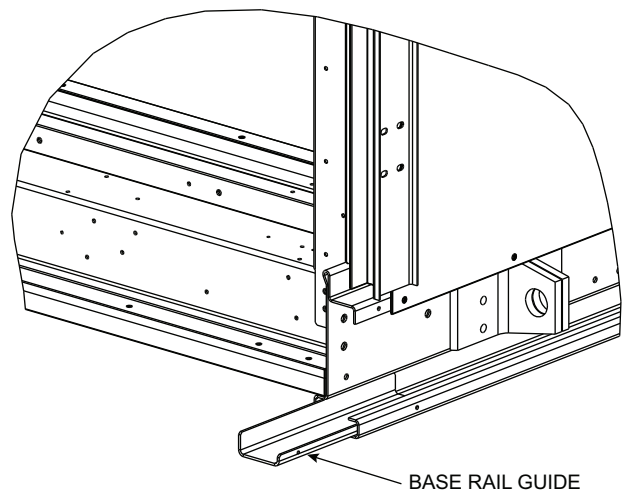

Fig. 57 — Base Rail Guide

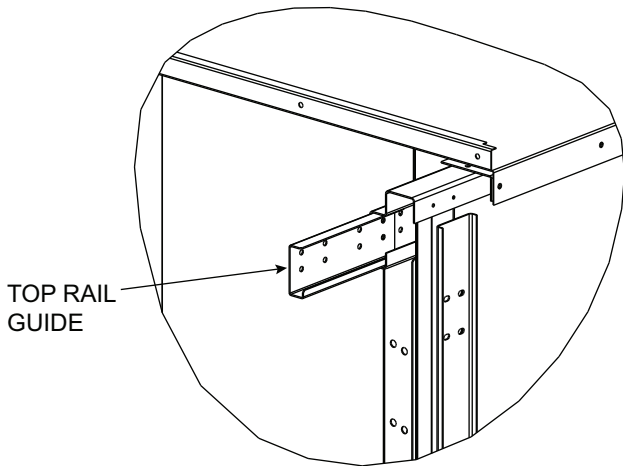

Fig. 58 — Top Rail Guide

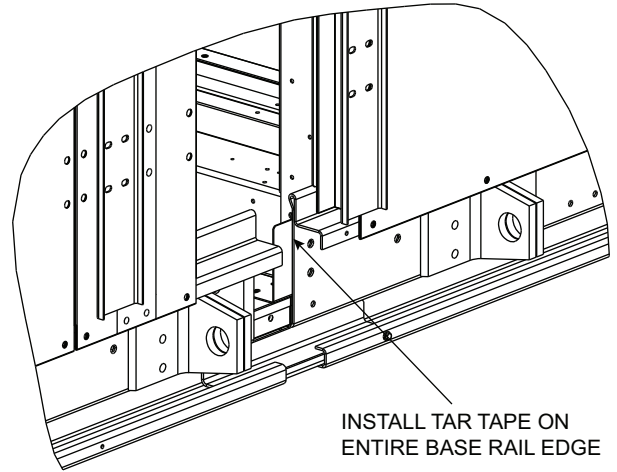

Fig. 61 — Tar Tape Location

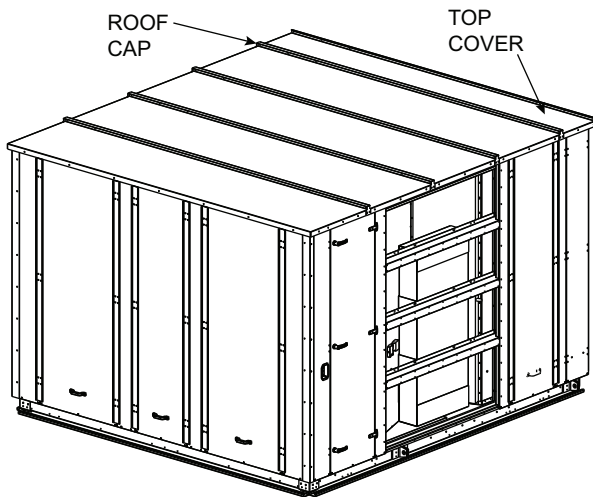

Fig. 59 — Roof Cap and Top Cover Removal

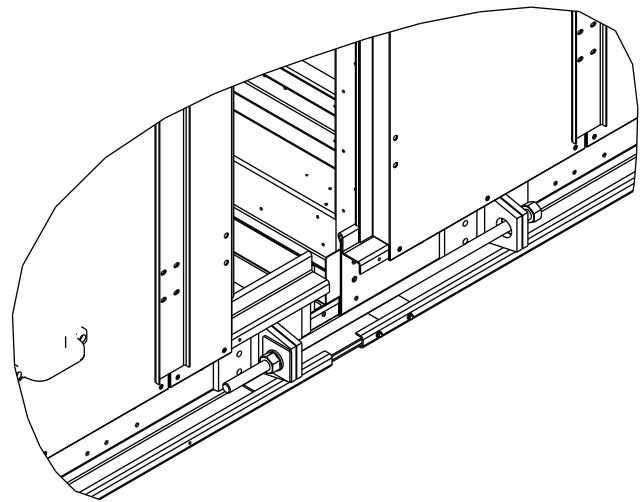

Fig. 62 — Secure Base Rails

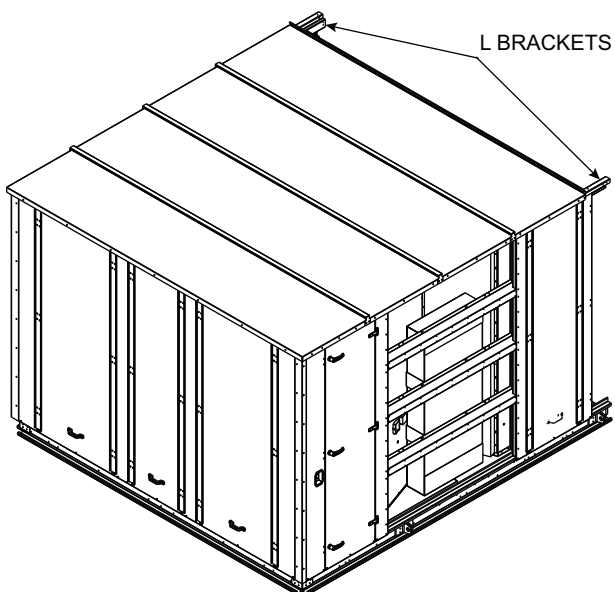

Fig. 60 — L Bracket Removal

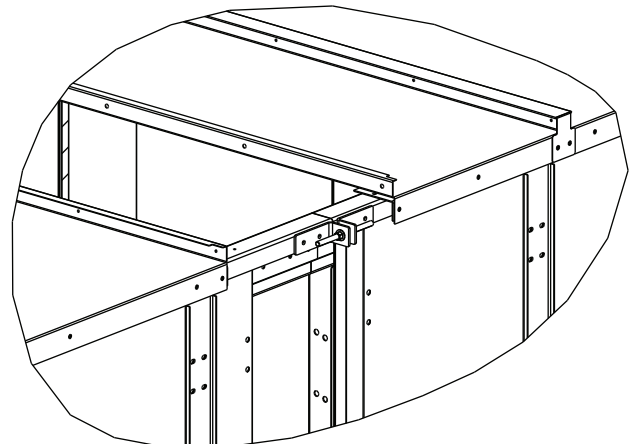
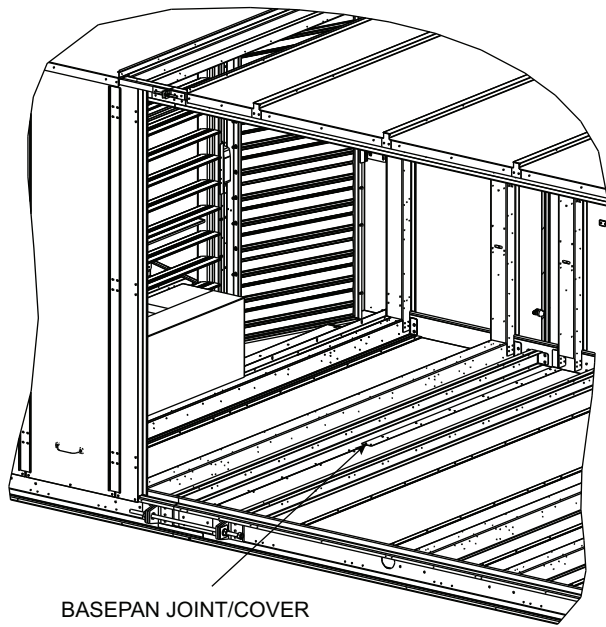
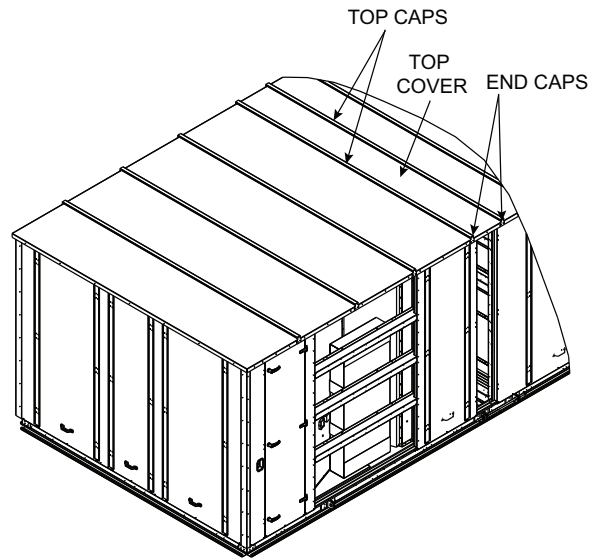

Fig. 63 — Top Rail Brackets



BASEPAN JOINT/COVER
Fig. 64 — Basepan Joint/Cover



**Fig. 66 — Main Unit and Return Section
 Top Cover Assemblies**

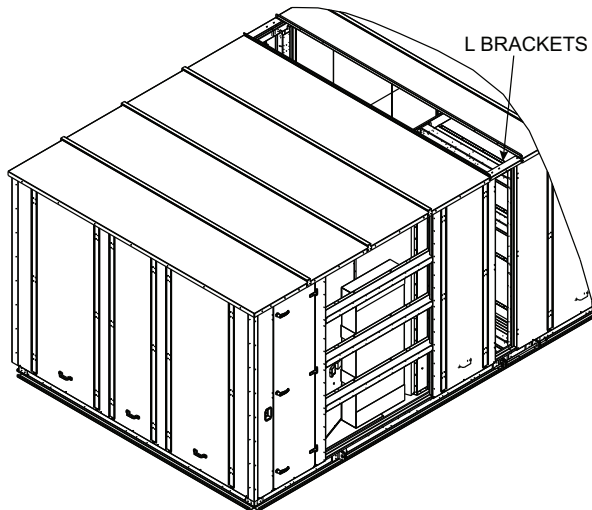

Fig. 65 — L Bracket Installation

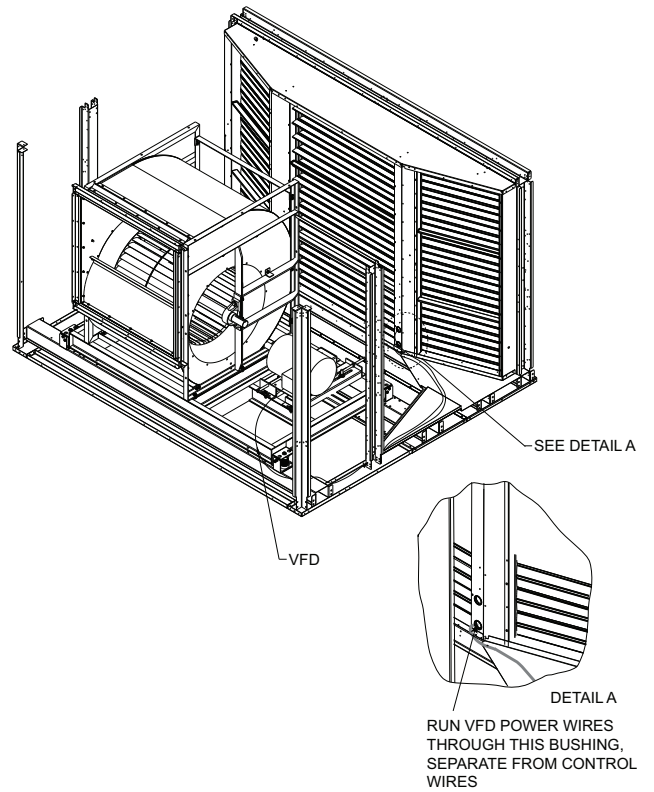

Fig. 67 — Wire Routing

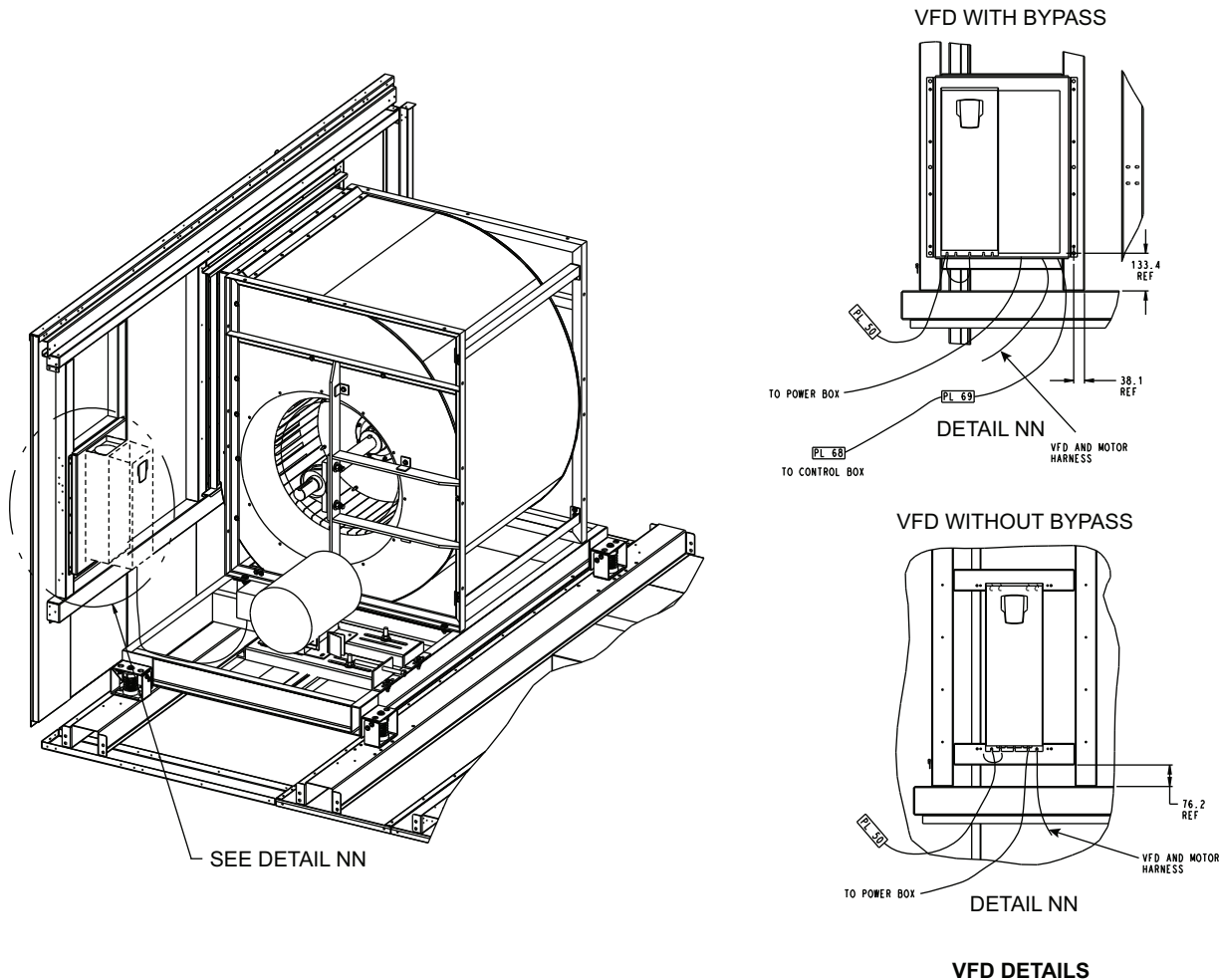

Fig. 68 — Return Section Component Locations

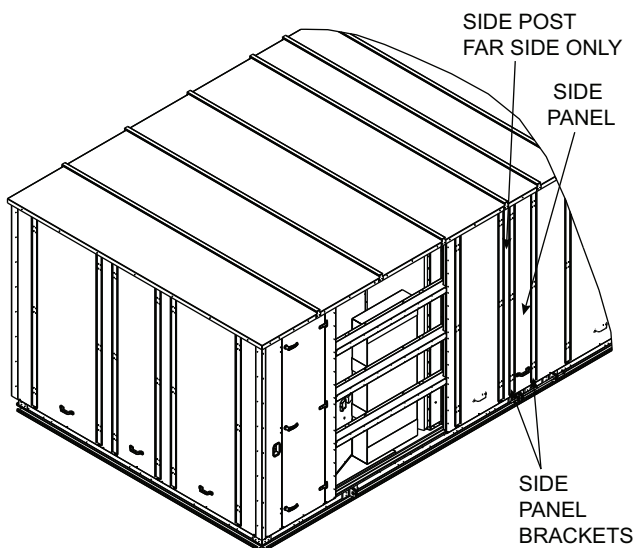

Fig. 69 — Side Post and Panel Installation

CONTROLS INSTALLATION

Constant Volume (CV) / Staged Air Volume (SAV™) Units — The 50N units may be used in applications with additional control features, options, or accessories. Refer to the appropriate accessory installation instructions for more information on installing that accessory. Control options and accessories available for CV/SAV units are:

- thermostats
- differential enthalpy sensor
- return air humidity sensor
- outdoor air humidity sensor
- relative humidity space sensor
- CO₂ sensors
- fan status switch
- filter pressure transducer
- return smoke detector
- CEM (controls expansion module) module
- EXB (economizer control board) module

CONTROL WIRING — The unit can be controlled with a Carrier-approved accessory electro-mechanical or electronic thermostat that has two stages of cooling, two stages of heating control, and an output for fan control. The thermostat may also include time of day scheduling or use scheduling routines built into the *ComfortLink* controls.

Install the thermostat according to the installation instructions shipped with the accessory thermostat. Locate thermostat assembly on a solid interior wall to sense average temperature.

Route thermostat cable or equivalent leads of colored wire from subbase terminals through conduit into the low voltage connections in the main control box. For thermostat TB201 connections, see Fig. 70.

NOTE: For wire runs up to 50 ft, use no. 18 AWG (American Wire Gage) insulated wire (35°C minimum). For over 75 ft, use no. 14 AWG insulated wire (35°C minimum). All wire larger than no. 18 AWG cannot be directly connected at the thermostat and will require a junction box and splice at the thermostat.

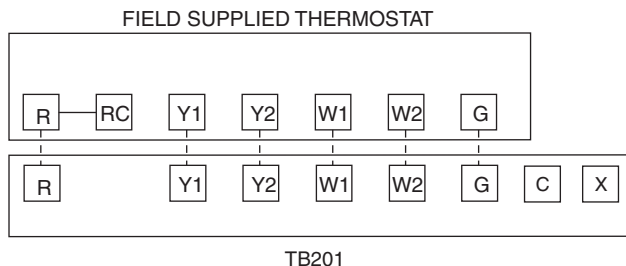

Fig. 70 — Field Control Thermostat Wiring

Variable Air Volume (VAV) Units — The 50N units may be used in applications with additional control features, options, or accessories. Refer to the appropriate accessory installation instructions for more information on installing that accessory. Refer to the Controls, Start-Up, Operation, Service, and Troubleshooting manual for more information concerning installation and configuration of options and accessories. Control options and accessories available for VAV units are:

- thermostats
- differential enthalpy sensor
- return air humidity sensor
- outdoor air humidity sensor
- relative humidity space sensor
- CO₂ sensors
- fan status switch
- filter pressure transducer
- return smoke detector
- CEM (controls expansion module) module
- EXB (economizer control board) module

VAV CONTROL WIRING — The recommended types of control wiring are shown below:

MANUFACTURER	PART NO.	
	Regular Wiring	Plenum Wiring
Alpha	1895	—
American	A21451	A48301
Belden	8205	884421
Columbia	D6451	—
Manhattan	M13402	M64430
Quabik	6130	—

SENSORS — Sensors should be wired using single twisted pairs of 20 AWG (American Wire Gage) conductor cable rated for the application, except for the T-56 accessory sensor which requires 3-conductor cable.

HUMIDITY CONTROL AND HOT WATER AND STEAM VALVES — These devices require 20 AWG twisted pair conductor cables rated for the application for the 4 to 20 mA signal.

SPACE TEMPERATURE SENSOR (T-55) — The space temperature sensor (P/N 33ZCT55SPT), if used, is wired to terminals in the unit main control box. To connect the space temperature sensor, see Fig. 71.

SPACE TEMPERATURE SENSOR (T-56) — The space temperature sensor (P/N 33ZCT56SPT), if used, is wired to

terminals in the unit main control box. To connect the space temperature sensor, see Fig. 71.

COMMUNICATING SPACE TEMPERATURE SENSOR (T-58) — The communicating space temperature sensor (P/N 33ZCT58SPT) is wired to the Carrier Comfort Network[®] (CCN) connections on TB202.

SPACE TEMPERATURE AVERAGING — Applications that require averaging using multiple space temperature sensors can be satisfied using either 4 or 9 sensors as shown in Fig. 72.

NOTE: Only Carrier sensors may be used for standard T-55 space averaging. Sensors must be used in multiples of 1, 4, and 9 only, with total sensors wiring not to exceed 1000 ft.

NOTE: Do not use T-56 sensors for space temperature averaging because the 5-degree offset function will not work in a multiple sensor application.

HEAT INTERLOCK RELAY (VAV Units Only — Not Necessary for Digital Air Volume Applications) — Variable air volume (VAV) units using morning warm-up and/or occupied heating require that room terminals be controlled to a position that provides the minimum required heating cfm or greater when the unit goes into Heating mode. The HIR (heat interlock relay) function is provided for this control. When the unit goes into Heating mode, the HIR is energized to provide switch closure or opening (depending on how the field-supplied power source is set up) to open the room terminals. The field connections for the HIR are at TB201 terminals 9 and 10. See Fig. 73.

Option and Accessory Control Wiring — The 50N Series units may be used in applications with additional control features, options, or accessories. Refer to the Controls, Start-Up, Operation, Service, and Troubleshooting manual for more information concerning installation and configuration of options and accessories. Figures 73-83 contain wiring information on the following features:

- heat interlock relay (Fig. 73)
- outdoor air enthalpy switch (Fig. 74)
- CO₂ space sensor (Fig. 75)
- filter status switch (Fig. 76)
- fan status switch (Fig. 77)
- space humidity sensor (Fig. 78)
- return air humidity sensor (Fig. 78)
- return air CO₂ sensor (Fig. 79)
- return air smoke detector (Fig. 80)
- smoke control — fire shutdown (Fig. 81)
- smoke control — purge (Fig. 82)
- smoke control — evacuation (Fig. 82)
- smoke control — pressurization (Fig. 82)
- CCN connections (Fig. 83)

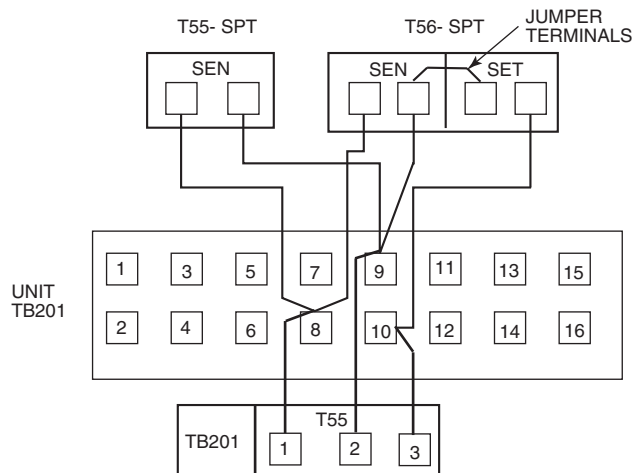
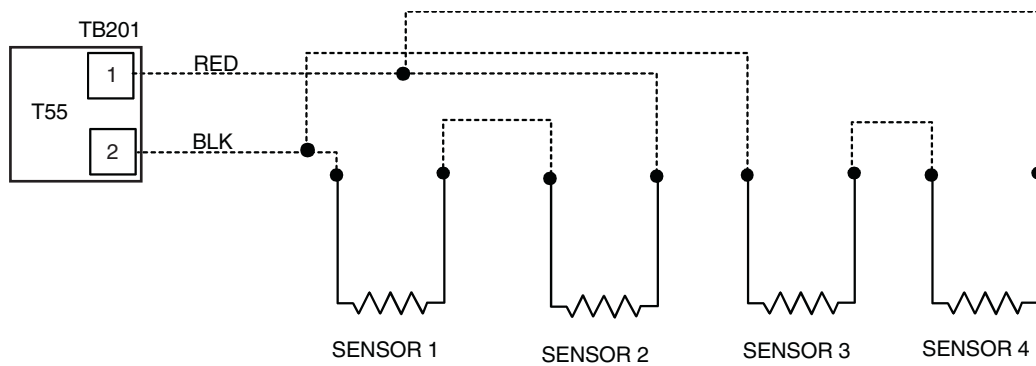
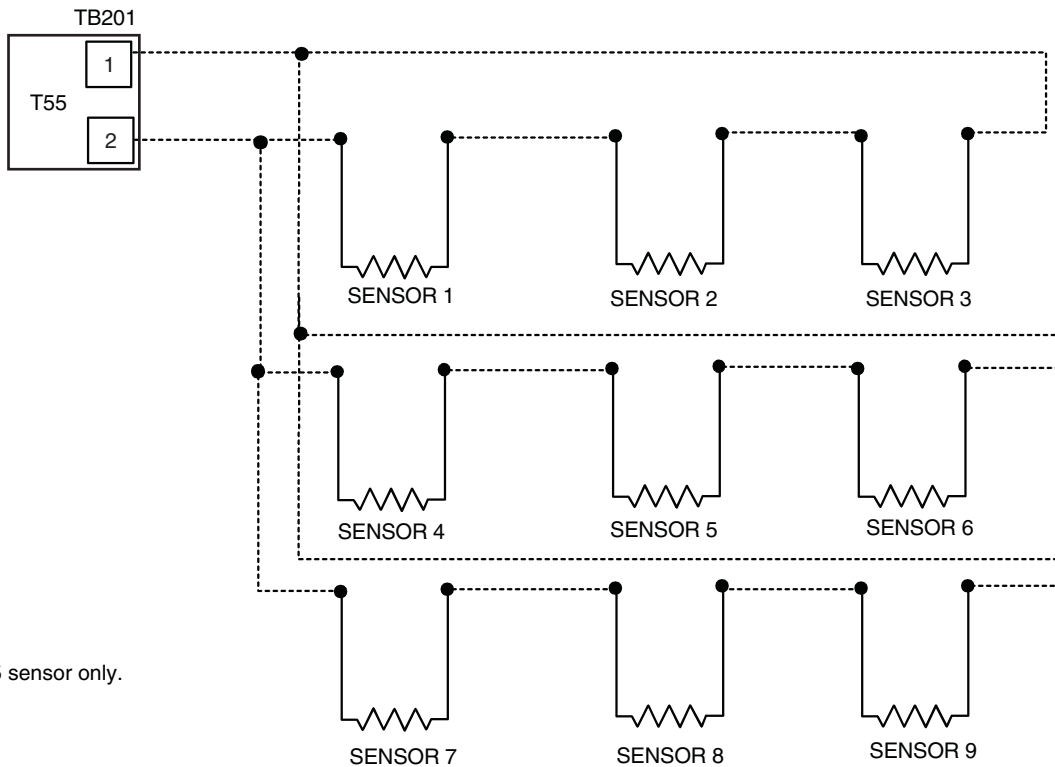

Fig. 71 — T-55 or T-56 Wiring



SPACE TEMPERATURE AVERAGING (4 SENSOR APPLICATION)



NOTE: Use T-55 sensor only.

SPACE TEMPERATURE AVERAGING (9 SENSOR APPLICATION)

Fig. 72 — Space Temperature Averaging Wiring

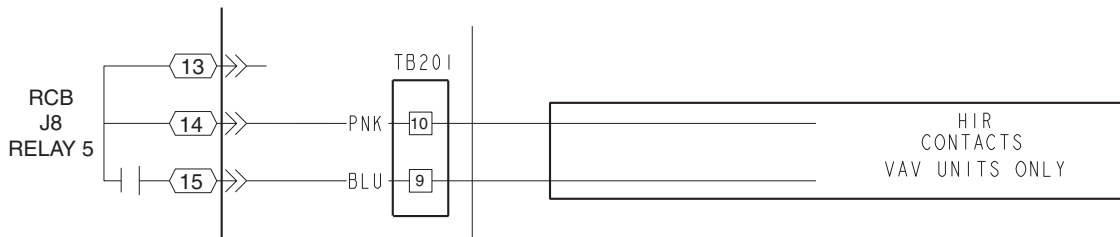

Fig. 73 — Heat Interlock Relay Wiring

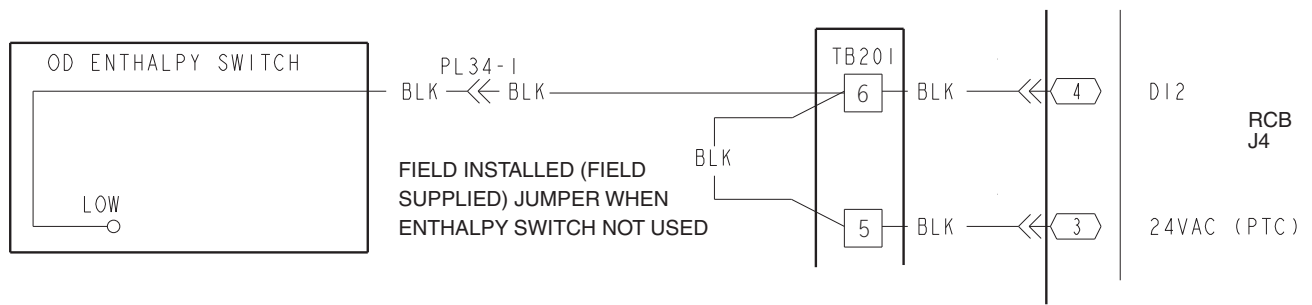

Fig. 74 — Outdoor Air Enthalpy Switch Wiring

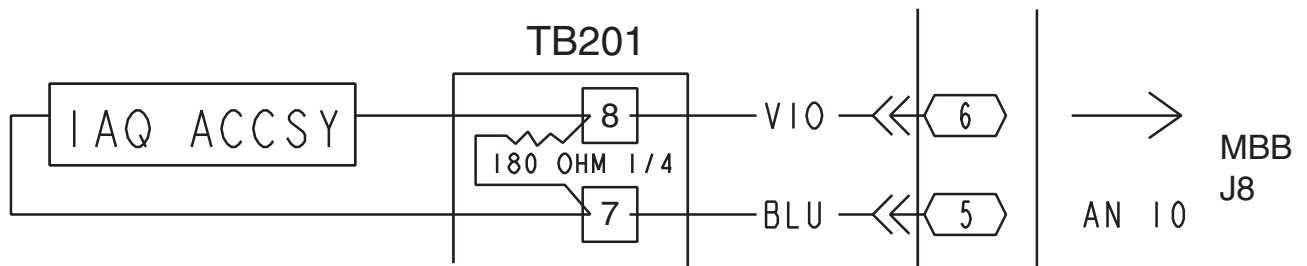

Fig. 75 — CO₂ Space Sensor Wiring

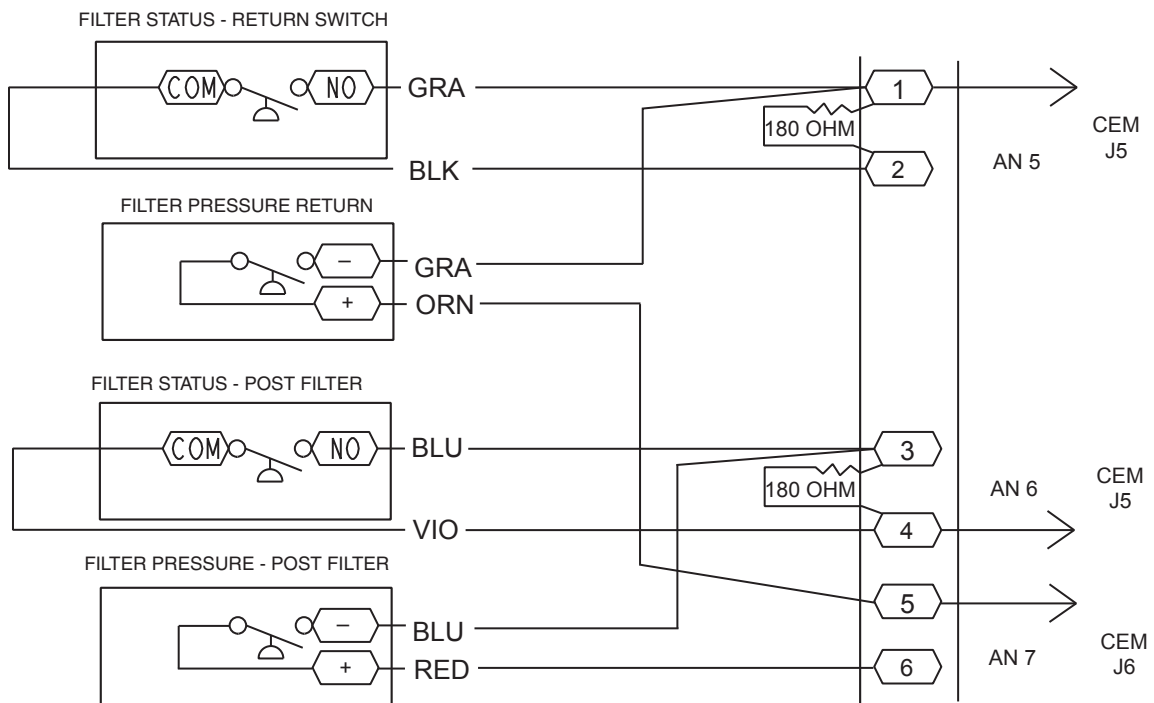

Fig. 76 — Filter Status Wiring

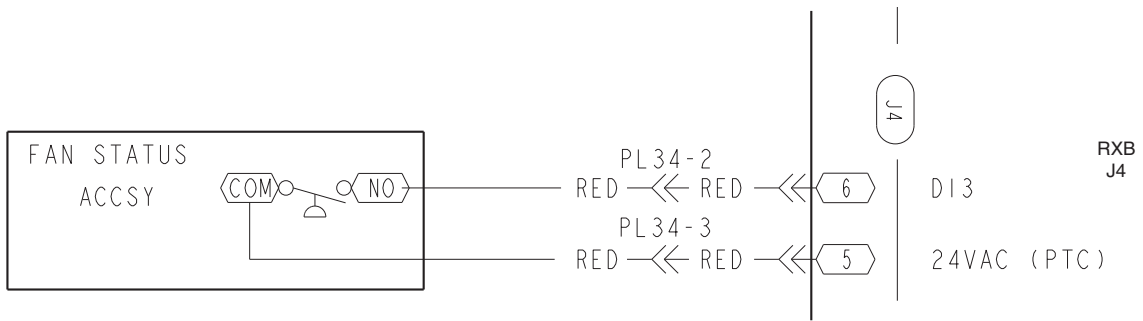

Fig. 77 — Fan Status Switch Wiring

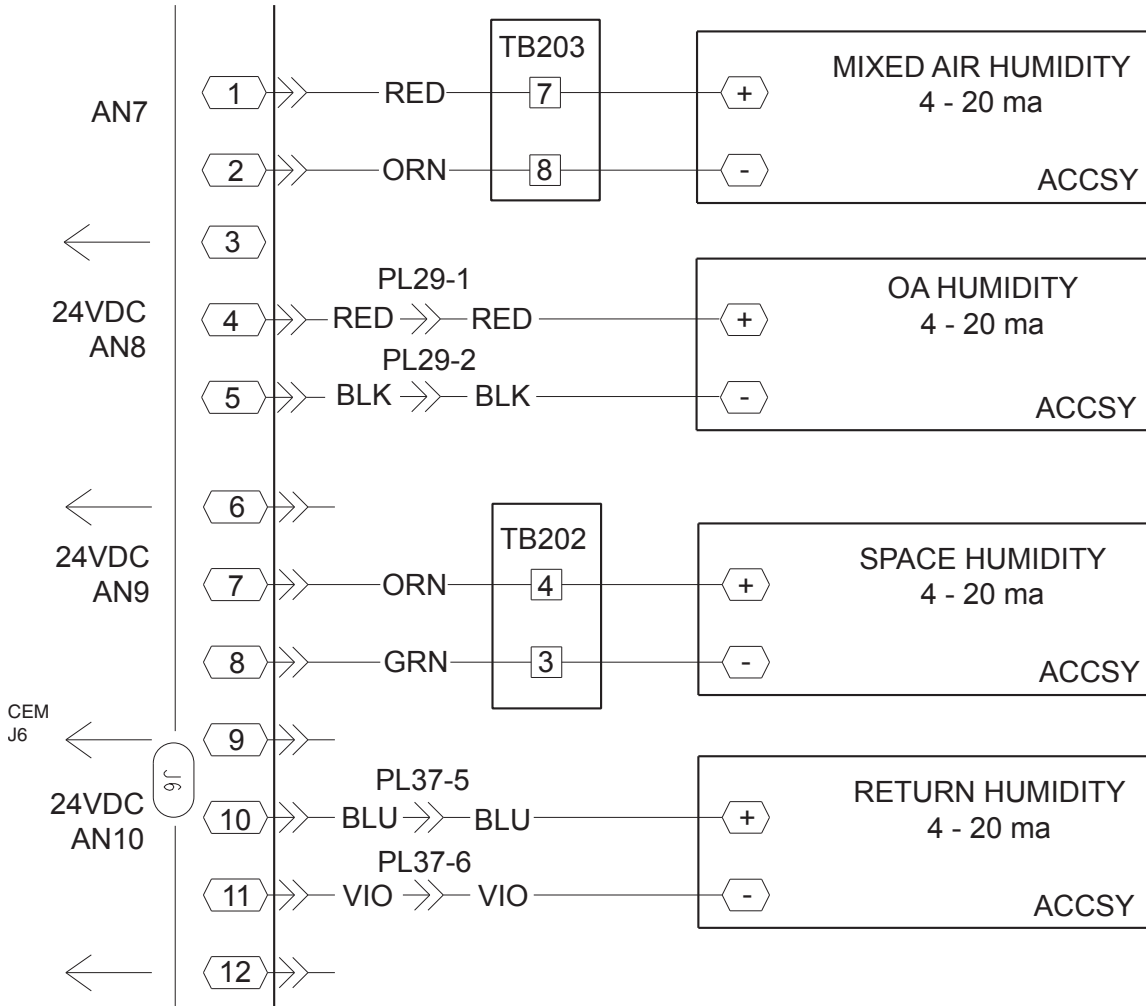

Fig. 78 — Space and Return Air Humidity Sensor Wiring

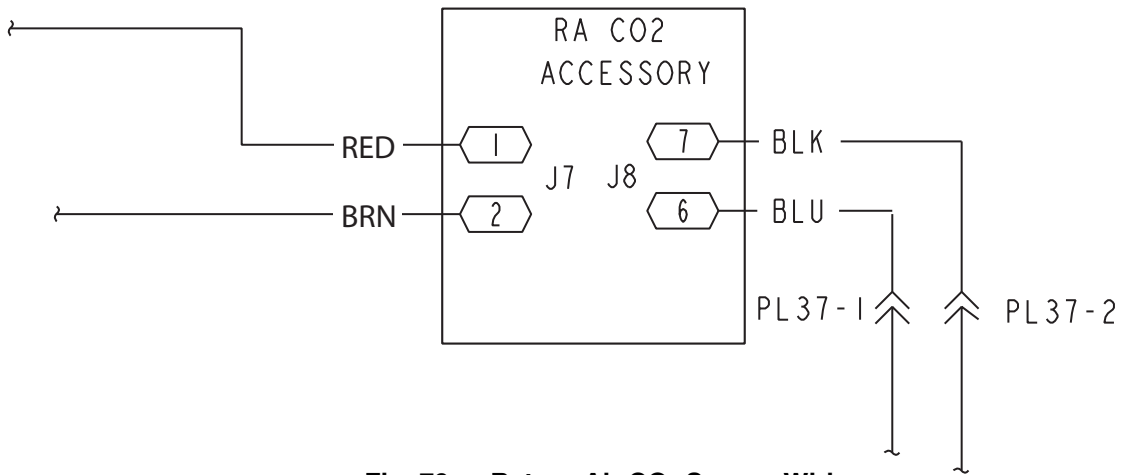

Fig. 79 — Return Air CO₂ Sensor Wiring

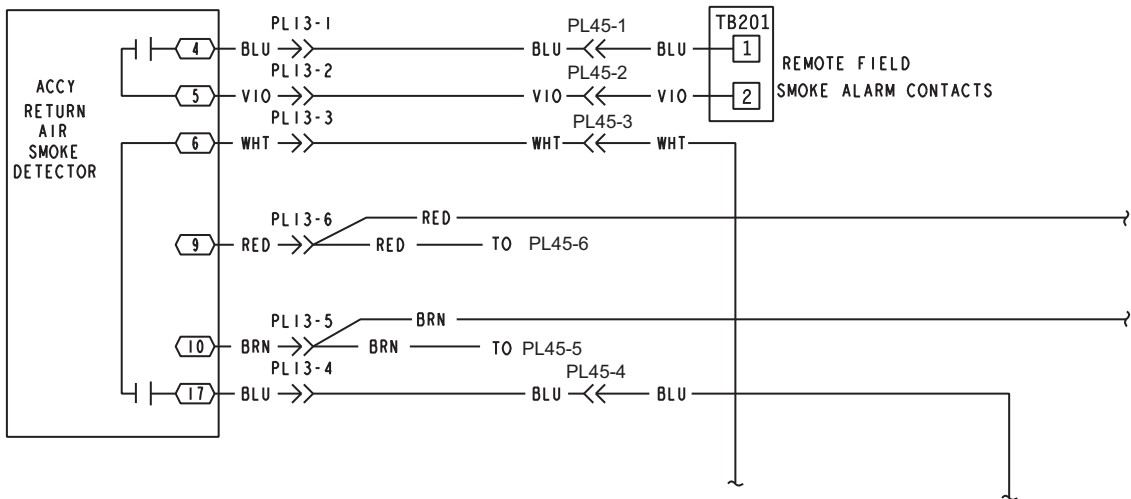

Fig. 80 — Return Air Smoke Detector Wiring

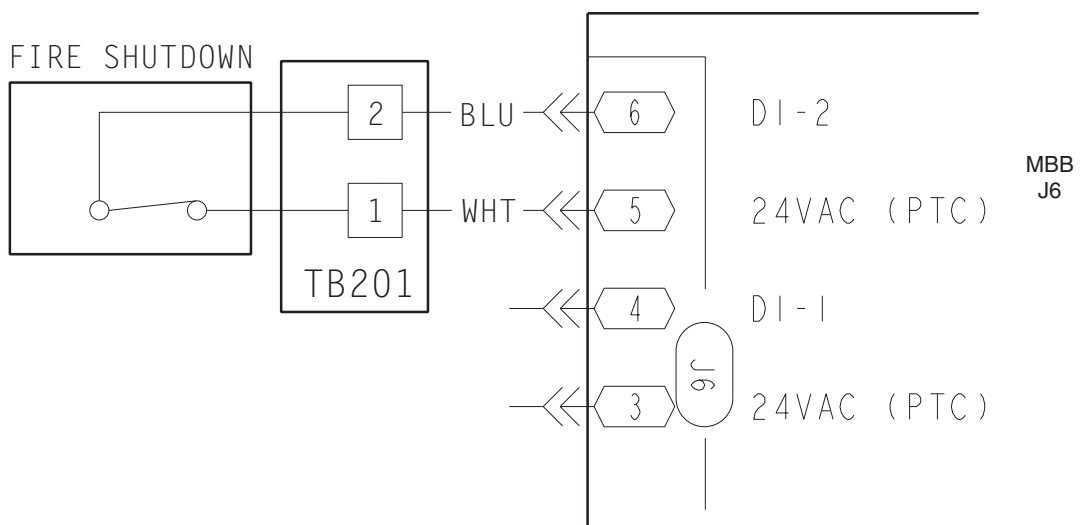

Fig. 81 — Fire Shutdown Wiring

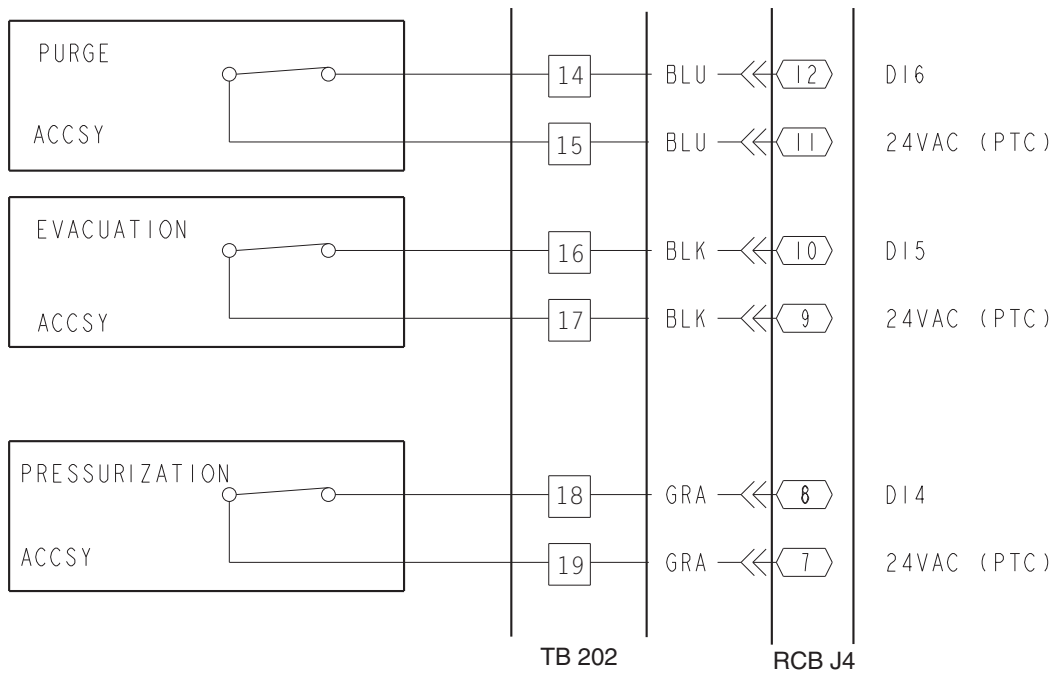

Fig. 82 — Purge, Evacuation, and Pressurization Wiring

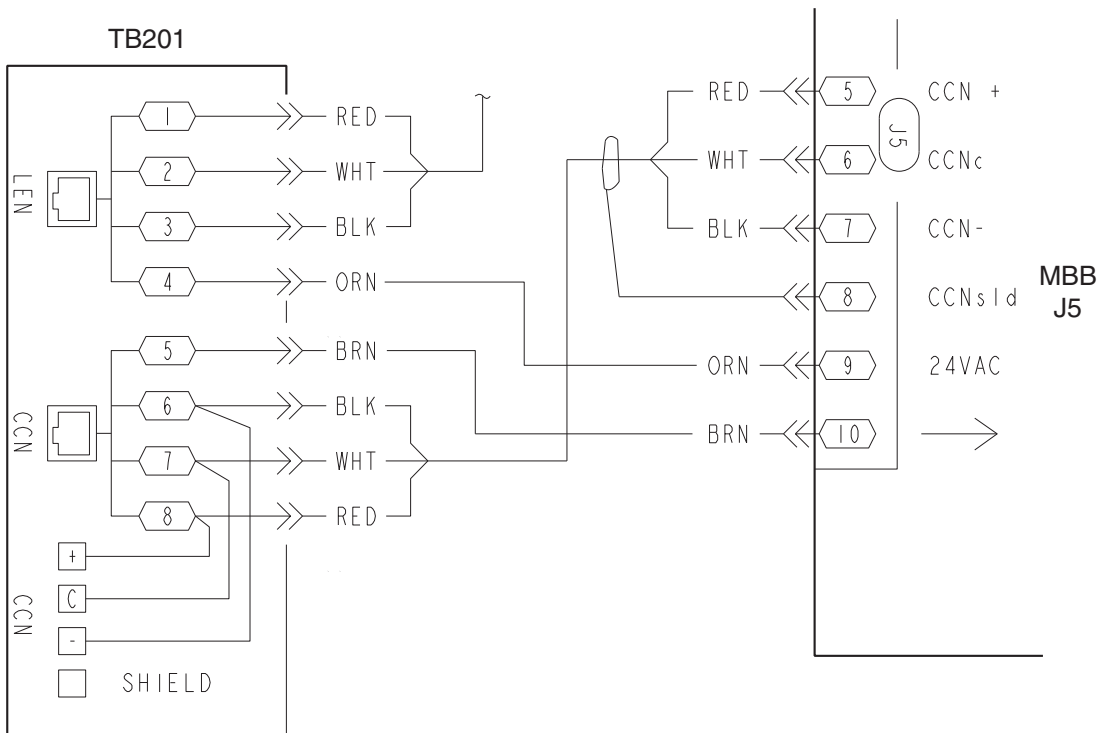

Fig. 83 — CCN Connections

Carrier Comfort Network® (CCN) Interface —
The 50N Series units can be connected to the CCN system if desired. The communication bus wiring is supplied and installed in the field. It consists of shielded, 3-conductor cable with shield wire.

The system elements are connected to the communication bus in a daisy chain arrangement. The positive pin of each system element communication connector must be wired to the positive pins of the system element on either side of it, the negative pins must be wired to the negative pins, and the signal pins must be wired to common pins. Wiring connections for the CCN system should be made at the terminal block using the screw terminals. The board also contains an RJ14 CCN plug that can be used to connect a field service computer. There is also another RJ14 LEN (Local Equipment Network) connection that is used to download software or connect a Navigator™ device.

NOTE: Conductors and drain wire must be 20 AWG minimum stranded, tinned copper. Individual conductors must be insulated with PVC, PVC/nylon, vinyl, Teflon¹, or polyethylene. An aluminum/polyester 100% foil shield and an outer jacket of PVC, PVC/nylon, chrome vinyl, or Teflon with a minimum operating temperature range of -4 to 140° F (-20°C to 60°C) is required. See Table 13 for cables that meet the requirements.

Table 13 — CCN Connection Approved Shielded Cables

MANUFACTURER	CABLE PART NO.
Alpha	2413 or 5463
American	A22503
Belden	8772
Columbia	02525

IMPORTANT: When connecting the CCN communication bus to a system element, use a color coding system for the entire network to simplify installation and checkout.

The following color code is recommended:

SIGNAL TYPE	CCN BUS CONDUCTOR INSULATION COLOR	COMM1 PLUG PIN NO.
+	RED	1
COMMON	WHITE	2
-	BLACK	3

NOTE: If a cable with a different color scheme is selected, a similar color code should be adopted for the entire network.

At each system element, the shields of its communication bus cables must be tied together. If the communication bus is entirely within one building, the resulting continuous field must be connected to a ground at one point only. If the communication bus cable exits from one building and enters another, the shields must be connected to grounds at the lightning suppressor in each building where the cable enters or exits the building (one point per building only).

To connect the unit to the network (Fig. 83):

1. Turn off power to the control box.
2. Cut the CCN wire and strip the ends of the red (+), white (common) and black (-) conductors. (If a different network color scheme is used, substitute appropriate colors.)

1. Teflon is a registered trademark of DuPont.

3. Wire the CCN to the screw terminals on the COMM board as follows:
 - a. Secure the red (+) wire to CCN screw terminal + on the COMM board.
 - b. Secure the white (common) wire to CCN screw terminal C on the COMM board.
 - c. Secure the black (-) wire to CCN screw terminal - on the COMM board.
 - d. Secure shield wire to CCN screw terminal SHIELD on the COMM board.

IMPORTANT: A shorted CCN bus cable will prevent some routines from running and may prevent unit from starting. If abnormal conditions occur, unplug the connector. If conditions return to normal, check CCN connector, and run new cable if necessary. A short in one section of the bus can cause problems with all system elements on the bus.

Optional UPC Open Installation

WIRING THE UPC OPEN TO THE MS/TP NETWORK — The UPC Open controller communicates using BACnet² on an MS/TP network segment communications at 9600 bps, 19.2 kbps, 38.4 kbps, or 76.8 kbps.

Wire the controllers on an MS/TP network segment in a daisy-chain configuration. Wire specifications for the cable are 22 AWG (American Wire Gage) or 24 AWG, low-capacitance, twisted, stranded, shielded copper wire. The maximum length is 2000 ft.

Install a BT485 terminator on the first and last controller on a network segment to add bias and prevent signal distortions due to echoing. See Fig. 84-86.

To wire the UPC Open controller to the BAS network:

1. Pull the screw terminal connector from the controller's BAS Port.
2. Check the communications wiring for shorts and grounds.
3. Connect the communications wiring to the BAS port's screw terminals labeled Net +, Net -, and Shield.

NOTE: Use the same polarity throughout the network segment.

4. Insert the power screw terminal connector into the UPC Open controller's power terminals if they are not currently connected.
5. Verify communication with the network by viewing a module status report. To perform a module status report using the BACview keypad/display unit, press and hold the "FN" key then press the "." key.

To install a BT485 terminator, push the BT485 on to the BT485 connector located near the BACnet connector.

NOTE: The BT485 terminator has no polarity associated with it.

To order a BT485 terminator, consult Commercial Products i-Vu® Open Control System Master Prices.

2. BACnet is a registered trademark of ASHRAE (American Society of Heating, Refrigerating and Air-Conditioning Engineers).

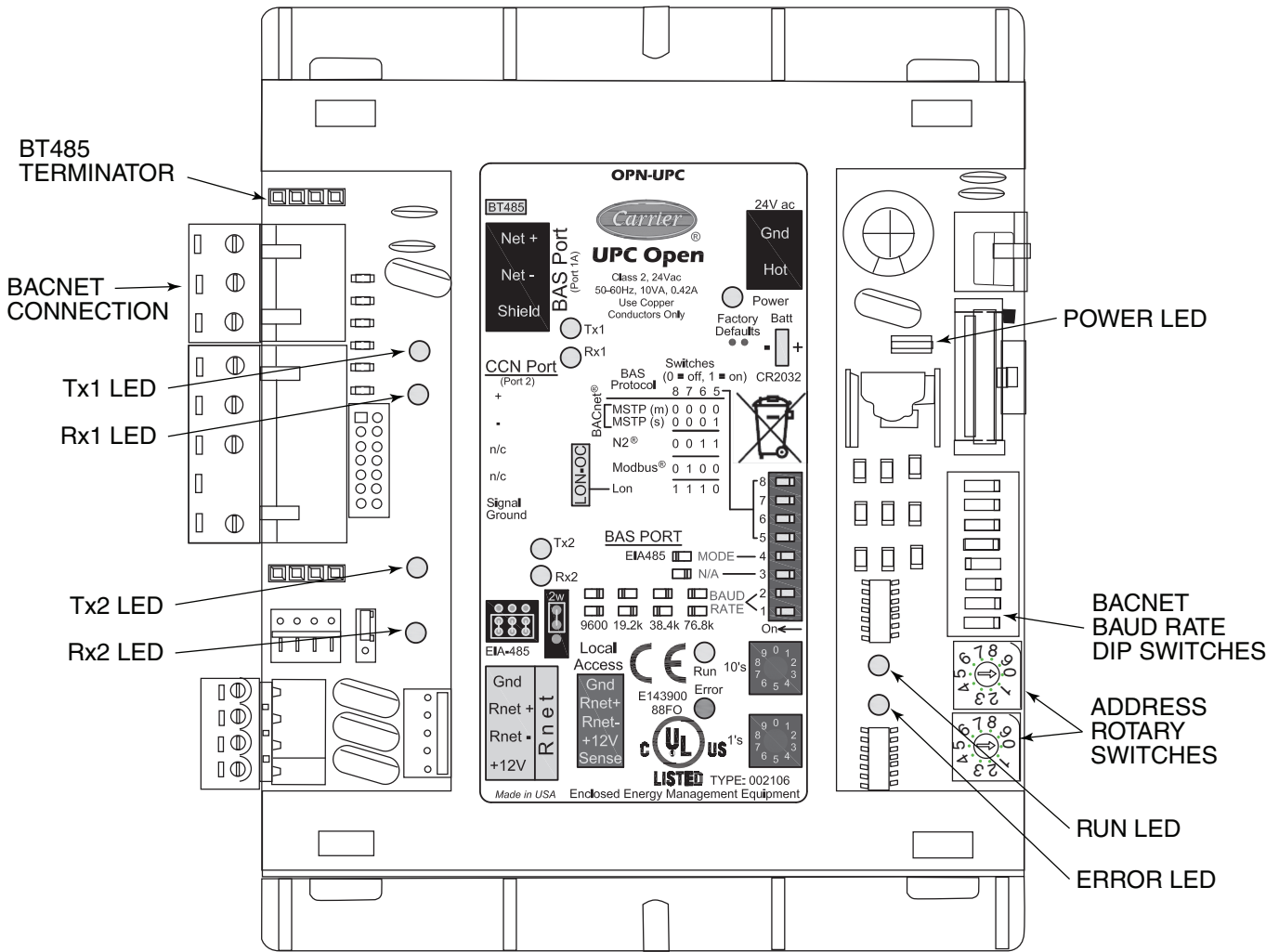

Fig. 84 — UPC Open Controller

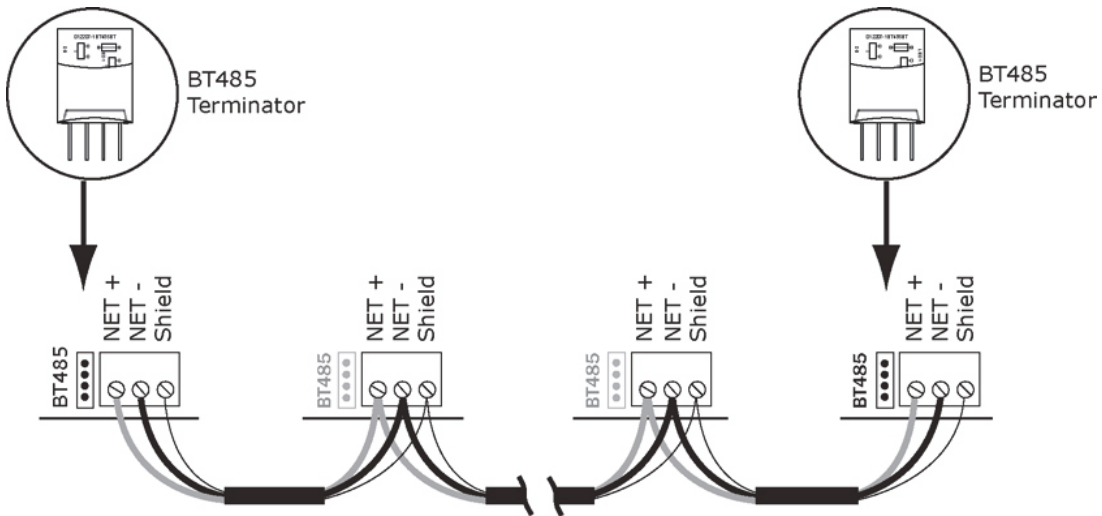

Fig. 85 — Open System Network Wiring

MS/TP WIRING RECOMMENDATIONS — Recommendations are shown in Tables 14 and 15. The wire jacket and UL temperature rating specifications list two acceptable alternatives. The Halar¹ specification has a higher temperature rating and a tougher outer jacket than the SmokeGard² specification, and it is appropriate for use in applications where the user is concerned about abrasion. The Halar jacket is also less likely to crack in extremely low temperatures.

NOTE: Use the specified type of wire and cable for maximum signal integrity.

Smoke Control Modes — Rooftop units can be used for aid in building smoke control in the event of a building fire. The available functions include: Fire Shutdown, Pressurization, Evacuation, and Smoke Purge. These functions are enhanced when multiple rooftop units are used to zone a building. See Table 16 and Fig. 81 and 82.

FIRE SHUTDOWN — Fire Shutdown mode terminates all unit operation (cooling, heating, supply fan, and power exhaust). This mode prevents recirculation of contaminated air back into the space. The mode will not allow admission into the space of unsuitable outside air. See Fig. 81 for wiring.

1.Halar is a registered trademark of Solvay Plastics.
2.SmokeGard is a trademark of AlphaGary-Mexichem Corp.

PRESSURIZATION — Pressurization mode is intended to keep smoke out of a zone. The factory-installed optional economizer is required for this function. Pressurization is accomplished by the following:

- opening the economizer (option)
- running the supply fan (VFD at normal duct static pressure set point)
- closing the power exhaust dampers (if installed as option)
- shutting off the power exhaust fans (if installed as option)

This allows the space to be over pressurized relative to adjacent zones and prevents or slows entry of smoke into this space from adjacent zones. See Fig. 82 for wiring.

EVACUATION — Evacuation mode removes smoke or undesirable air from interior spaces without reintroducing unsuitable air. The factory-installed optional economizer with optional power exhaust is required for this function. Evacuation is accomplished by the following:

- turning the supply fan off
- opening the economizer (option required)
- running the exhaust fans (option required)
- opening the exhaust dampers

See Fig. 82 for wiring.

Table 14 — MS/TP Wiring Recommendations

SPECIFICATION	RECOMMENDATION
Cable	Single twisted pair, low capacitance, CL2P, 22 AWG (7x30), TC foam FEP, plenum rated cable
Conductor	22 or 24 AWG stranded copper (tin plated)
Insulation	Foamed FEP 0.015 in. (0.381 mm) wall 0.060 in. (1.524 mm) O.D.
Color Code	Black/White
Twist Lay	2 in. (50.8 mm) lay on pair 6 twists/foot (20 twists/meter) nominal
Shielding	Aluminum/Mylar shield with 24 AWG TC drain wire
Jacket	SmokeGard Jacket (SmokeGard PVC) 0.021 in. (0.5334 mm) wall 0.175 in. (4.445 mm) O.D. Halar Jacket (E-CTFE) 0.010 in. (0.254 mm) wall 0.144 in. (3.6576 mm) O.D.
DC Resistance	15.2 Ohms/1000 feet (50 Ohms/km) nominal
Capacitance	12.5 pF/ft (41 pF/meter) nominal conductor to conductor
Characteristic Impedance	100 Ohms nominal
Weight	12 lb/1000 feet (17.9 kg/km)
UL Temperature Rating	SmokeGard 167°F (75°C) Halar -40 to 302°F (-40 to 150°C)
Voltage	300 Vac, power limited
Listing	UL: NEC CL2P, or better

LEGEND

- AWG — American Wire Gage
- CL2P — Class 2 Plenum Cable
- DC — Direct Current
- FEP — Fluorinated Ethylene Polymer
- NEC — National Electrical Code
- O.D. — Outside Diameter
- TC — Tinned Copper
- UL — Underwriters Laboratories

Table 15 — Open System Wiring Specifications and Recommended Vendors

WIRING SPECIFICATIONS		RECOMMENDED VENDORS AND PART NUMBERS			
Wire Type	Description	Connect Air International	Belden	RMCORP	Contractors Wire and Cable
MS/TP Network (RS-485)	22 AWG, single twisted shielded pair, low capacitance, CL2P, TC foam FEP, plenum rated. See MS/TP Installation Guide for specifications.	W221P-22227	—	25160PV	CLP0520LC
	24 AWG, single twisted shielded pair, low capacitance, CL2P, TC foam FEP, plenum rated. See MS/TP Installation Guide for specifications.	W241P-2000F	82841	25120-OR	—
Rnet	4 conductor, unshielded, CMP, 18 AWG, plenum rated.	W184C-2099BLB	6302UE	21450	CLP0442

LEGEND

- AWG — American Wire Gage
- CL2P — Class 2 Plenum Cable
- CMP — Communications Plenum Rated
- FEP — Fluorinated Ethylene Polymer
- TC — Tinned Copper

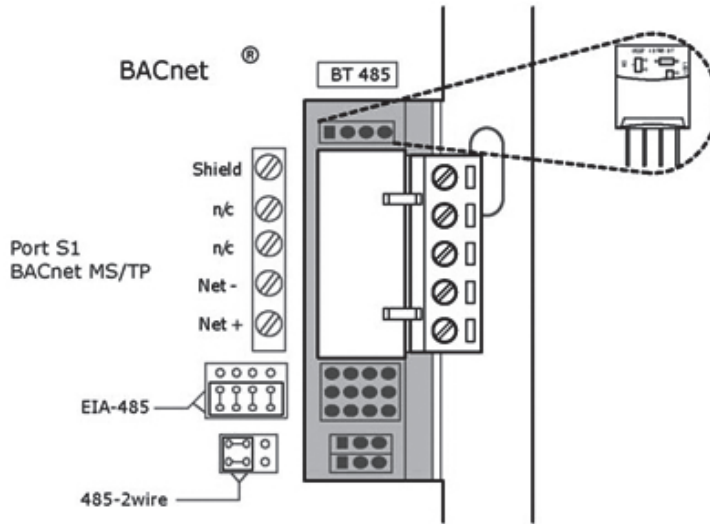

Fig. 86 — BT485 Installation

SMOKE PURGE — Smoke Purge mode removes smoke from the interior spaces and replaces it with fresh outside air. The factory-installed optional economizer with optional power exhaust are required for this function. Smoke purge is accomplished by the following:

- turning supply fan on
- opening the economizer (option required)
- running the exhaust fans (option required)
- opening the exhaust dampers

See Fig. 82 for wiring.

SMOKE CONTROL INSTALLATION — Implementation of the various smoke control modes on these units requires the installer to modify the unit wiring to add contacts (via either manual switches or relays) that will selectively interrupt and override standard factory control sequences. See Table 16 and 17 and Fig. 81 and 82 for more information.

Table 16 — Smoke Control Modes

FUNCTION	MODE			
	Fire Shutdown	Pressurization	Evacuation*	Smoke Purge*
Supply Fan	Off	On	Off	On
VFD†	—	Open/On	—	Open/On
Economizer	Closed	Open	Open	Open
Return Air Damper	Open	Closed	Closed	Closed
Exhaust Fans	Off	Off	On	On
Exhaust Damper	Closed	Closed	Open	Open

LEGEND

- VAV — Variable Air Volume
- VFD — Variable Frequency Drive

*Power exhaust option required for this mode.

†Applicable to VAV units with appropriate options.

Table 17 — ERV Unit Smoke Control Modes

SMOKE/FIRE MODE	WHEEL MOTOR	INDOOR/SUPPLY FAN VFD SPEED	POWER EXHAUST VFD SPEED	RETURN FAN VFD SPEED	INTAKE AIR ACTUATOR POSITIONS	INTAKE BYPASS ACTUATOR POSITIONS	RETURN AIR DAMPER POSITION	EXHAUST BYPASS ACTUATOR POSITION	RETURN FAN BYPASS ACTUATOR POSITION	INDOOR/SUPPLY FAN BYPASS ACTUATOR POSITION
Fire Shutdown Mode	OFF	0%	0%	0%	CLOSED	CLOSED	OPEN	CLOSED	CLOSED	CLOSED
Pressurization Mode	OFF	100%	0%	0%	OPEN	OPEN	CLOSED	CLOSED	CLOSED	OPEN
Evacuation Mode	OFF	0%	100%	100%	CLOSED	CLOSED	OPEN	OPEN	OPEN	CLOSED
Smoke Purge Mode	OFF	100%	100%	100%	OPEN	OPEN	CLOSED	OPEN	OPEN	OPEN
Multiple Smoke/ Fire Modes	OFF	0%	0%	0%	CLOSED	CLOSED	OPEN	CLOSED	CLOSED	CLOSED

