



Installation, Start-Up, and Service Instructions

CONTENTS

	Page
SAFETY CONSIDERATIONS	1
GENERAL	2
GREENHOUSE GAS REGULATION	3
INSTALLATION	3
Step 1 — Check Jobsite	3
Step 2 — Check Unit	3
• STORAGE	
• PROTECTION	
• INSPECT UNIT	
Step 3 — Locate Unit	8
Step 4 — Mount the Unit	8
• DUCT FLANGES	
• HORIZONTAL UNITS	
• VERTICAL UNITS	
Step 5 — Check Duct System	10
Step 6 — Install Condensate Drain	10
Step 7 — Pipe Connections	10
• PIPING	
• WATER LOOP APPLICATIONS	
• GROUND-LOOP APPLICATIONS	
• GEOTHERMAL CLOSED LOOP SYSTEMS	
• OPEN WELL WATER SYSTEMS	
• INSTALLATION OF SUPPLY AND RETURN HOSE KIT	
Step 8 — Wire Field Power Supply	14
• HIGH VOLTAGE	
• ELECTRICAL - LOW VOLTAGE	
Step 9 — Wire Field Controls	19
• SAFETY DEVICES AND COMPLETE C CONTROL	
PRE-START-UP	23
System Checkout	23
Fan Motor Speeds /Changing Speeds	23
START-UP	24
Operating Limits	24
Scroll Compressor Rotation	25
Unit Start-Up	25
Flow Regulation	30
Flushing	30
Antifreeze	31
Cooling Tower/Boiler Systems	31
OPERATION	32
Power Up Mode	32
SERVICE	32
Filters	32
Condensate Drain Pans	32
Refrigerant System	32
Compressor	32
Fan Motors	32
Condensate Drain Cleaning	32
Air Coil Cleaning	32
Condenser Cleaning	33
Checking System Charge	33
Refrigerant Charging	33
TROUBLESHOOTING	34
Thermistor	34
Control Sensors	34
Thermostatic Expansion Valves	34
Disposal of Unit	36
50PCH,PCV START-UP CHECKLIST	CL-1

IMPORTANT: Read the entire instruction manual before starting installation.

SAFETY CONSIDERATIONS

Installation and servicing of air-conditioning equipment can be hazardous due to system pressure and electrical components. Only trained and qualified service personnel should install, repair, or service air-conditioning equipment.

Untrained personnel can perform basic maintenance functions of cleaning coils and filters and replacing filters. All other operations should be performed by trained service personnel. When working on air-conditioning equipment, observe precautions in the literature, tags and labels attached to the unit, and other safety precautions that may apply.

Improper installation, adjustment, alteration, service, maintenance, or use can cause explosion, fire, electrical shock or other conditions which may cause personal injury or property damage. Consult a qualified installer, service agency, or your distributor or branch for information or assistance. The qualified installer or agency must use factory-authorized kits or accessories when modifying this product. Refer to the individual instructions packaged with the kits or accessories when installing.

Follow all safety codes. Wear safety glasses and work gloves. Use quenching cloth for brazing operations. Have fire extinguisher available. Read these instructions thoroughly and follow all warnings or cautions attached to the unit. Consult local building codes and the National Electrical Code (NEC, U.S.A.) for special installation requirements.

Understand the signal words — DANGER, WARNING, and CAUTION. DANGER identifies the most serious hazards which will result in severe personal injury or death. WARNING signifies hazards that could result in personal injury or death. CAUTION is used to identify unsafe practices, which would result in minor personal injury or product and property damage.

Recognize safety information. This is the safety-alert symbol (⚠). When you see this symbol on the unit and in instructions or manuals, be alert to the potential for personal injury.

GREENHOUSE GAS REGULATION

F-Gas Regulation (517/2014) — This device utilizes a fluorinated greenhouse gas (F-gas), which is regulated under the EU F-Gas Regulation (517/2014). The hermetically sealed refrigerant circuit is factory charged with HFC-410A refrigerant. Refrigerant charge amounts by unit size, global warming potential (GWP), and equivalent CO₂ tonnage (t) can be found in Table 1 and on the unit label. The installer, building operator, and service provider must conform to usage, handling, and record-keeping requirements as stated in the regulation.

Table 1 — Refrigerant Charge and CO₂ Equivalent

	MODEL	REFRIGERANT CHARGE (KG)	CO ₂ EQUIVALENT TONNAGE (t) OF REFRIGERANT CHARGE
	50PCH009	0.540	1.127
	50PCH012	0.540	1.127
	50PCH015	0.540	1.127
	50PCH018	0.824	1.720
	50PCH024	0.824	1.720
	50PCH030	1.108	2.313
	50PCH036	1.307	2.729
	50PCH042	1.222	2.551
	50PCH048	1.250	2.610
GWP CO₂ EQUIVALENT - 2088	50PCH060	1.989	4.152
	50PCH070	1.818	3.796
	50PCV009	0.426	0.890
	50PCV012	0.597	1.246
	50PCV015	0.540	1.127
	50PCV018	0.795	1.661
	50PCV024	0.824	1.720
	50PCV030	1.051	2.195
	50PCV036	1.364	2.847
	50PCV042	1.364	2.847
	50PCV048	1.477	3.085
	50PCV060	1.676	3.500
	50PCV070	2.074	4.330

GWP — LEGEND
— Global Warming Potential

⚠ WARNING

Electrical shock can cause personal injury or death. Before installing or servicing system, always turn off main power to system. There may be more than one disconnect switch. Turn off accessory heater power if applicable.

⚠ WARNING

DO NOT USE TORCH to remove any component. System contains oil and refrigerant under pressure.

To remove a component, wear protective gloves and goggles and proceed as follows:

- a. Shut off electrical power to unit.
- b. Recover refrigerant to relieve all pressure from system using both high-pressure and low pressure ports.
- c. Traces of vapor should be displaced with nitrogen and the work area should be well ventilated. Refrigerant in contact with an open flame produces toxic gases.
- d. Cut component connection tubing with tubing cutter and remove component from unit. Use a pan to catch any oil that may come out of the lines and as a gage for how much oil to add to the system.
- e. Carefully unsweat remaining tubing stubs when necessary. Oil can ignite when exposed to torch flame.

Failure to follow these procedures may result in personal injury and death.

⚠ CAUTION

DO NOT re-use compressor oil or any oil that has been exposed to the atmosphere. Dispose of oil per local codes and regulations. **DO NOT** leave refrigerant system open to air any longer than the actual time required to service the equipment. Seal circuits being serviced and charge with dry nitrogen to prevent oil contamination when timely repairs cannot be completed. Failure to follow these procedures may result in damage to the equipment.

GENERAL

This Installation and Start-Up Instructions literature is for Aquazone™ 50PC compact water source heat pump systems.

Water source heat pumps (WSHPs) are single-package horizontally and vertically mounted units with electronic controls designed for year-round cooling and heating.

IMPORTANT: The installation of water source heat pump units and all associated components, parts, and accessories which make up the installation shall be in accordance with the regulations of ALL authorities having jurisdiction and **MUST** conform to all applicable codes. It is the responsibility of the installing contractor to determine and comply with ALL applicable codes and regulations.

INSTALLATION

Step 1 — Check Jobsite — Installation, operation and maintenance instructions are provided with each unit. Before unit start-up, read all manuals and become familiar with the unit and its operation. Thoroughly check out the system before operation. Complete the inspections and instructions listed below to prepare a unit for installation. See Tables 2 and 3 for unit physical data.

IMPORTANT: If the refrigerant charge is adjusted from the factory charge levels, it must be noted on the unit label and in related documentation as required by EU Regulation (517/2014).

The WSHP units are designed for indoor installation only. Be sure to allow adequate space around the unit for servicing. See Fig. 1 and 2 for overall unit dimensions. See Table 4 for corner weights information.

CAUTION

To avoid equipment damage, do not use these units as a source of heating or cooling during the construction process. The mechanical components and filters used in these units quickly become clogged with construction dirt and debris which may cause system damage.

Step 2 — Check Unit — Upon receipt of shipment at the jobsite, carefully check the shipment against the bill of lading. Make sure all units have been received. Inspect the carton or crating of each unit, and inspect each unit for damage. Ensure the shipping company makes proper notation of any shortages or damage on all copies of the freight bill. Concealed damage not discovered during unloading must be reported to the shipping company within 15 days of receipt of shipment.

NOTE: It is the responsibility of the purchaser to file all necessary claims with the shipping company.

1. Be sure that the location chosen for unit installation provides ambient temperatures maintained above freezing.
2. Be sure the installation location is isolated from sleeping areas, private offices and other acoustically sensitive spaces.
3. Be sure unit is mounted at a height sufficient to provide an adequate slope of the condensate lines. If an appropriate slope cannot be achieved, a field-supplied condensate pump may be required.
4. On horizontal units, allow adequate room below the unit for condensate drain trap and do not locate the unit above supply piping.
5. Provide sufficient space for duct connection. Do not allow the weight of the ductwork to rest on the unit.
6. Provide adequate clearance for filter replacement and drain pan cleaning. Do not allow piping, conduit, etc. to block filter access.
7. Provide sufficient access to allow maintenance and servicing of the fan and fan motor, compressor and coils.

Removal of the entire unit from the closet should not be necessary.

8. Provide an unobstructed path to the unit within the closet or mechanical room. Space should be sufficient to allow return air to freely enter the space.
9. Provide ready access to water valves and fittings, and screwdriver access to unit side panels, discharge collar, and all electrical connections.
10. Where access to side panels is limited, pre-removal of the control box side mounting screws may be necessary for future servicing.

STORAGE — If the equipment is not needed for immediate installation upon its arrival at the jobsite, it should be left in its shipping carton and stored in a clean, dry area. Units must only be stored or moved in the normal upright position as indicated by the UP arrows on each carton at all times. If unit stacking is required, stack units as follows: vertical units should not be stacked. Horizontal units can be stacked no more than two high.

PROTECTION — Once the units are properly positioned on the jobsite, cover them with either a shipping carton, vinyl film, or an equivalent protective covering. Cap open ends of pipes stored on the jobsite. This precaution is especially important in areas where painting, plastering, or spraying of fireproof material, etc. is not yet complete. Foreign material that accumulates within the units can prevent proper start-up and require costly clean-up operations.

Before installing any of the system components, be sure to examine each pipe, fitting, and valve, and remove any dirt or foreign material found in or on these components.

CAUTION

DO NOT store or install units in corrosive environments or in locations subject to temperature or humidity extremes (e.g., attics, garages, rooftops, etc.). Corrosive conditions and high temperature or humidity can significantly reduce performance, reliability, and service life. Always move units in an upright position. Tilting units on their sides may cause equipment damage.

INSPECT UNIT — To prepare the unit for installation, complete the procedures listed below:

1. Compare the electrical data on the unit nameplate with ordering and shipping information to verify that the correct unit has been shipped.
2. Verify that the unit is the correct model for the entering water temperature of the job.
3. Do not remove the packaging until the unit is ready for installation.
4. Verify that the refrigerant tubing is free of kinks or dents, and that it does not touch other unit components.
5. Inspect all electrical connections. Be sure connections are clean and tight at the terminals.
6. Remove any blower support styrofoam from underneath the blower.
7. Remove any access panel screws that may be difficult to remove once unit is installed.

Table 2 — Physical Data — 50PCH,PCV (009-070) Units ETL Rated

50PCH,PCV UNIT	009	012	015	018	024	030
COMPRESSOR (1 each)	Rotary			Reciprocating		
Maximum Water Working Pressure (kPa)	2758					
PSC FAN MOTOR AND BLOWER						
Fan Motor Type/Speeds	PSC/3					
Fan Motor (W)	75			186		
Blower Wheel Size (Dia x W) (mm)	114.3 x 114.3	139.7 x 114.3	228.6 x 177.8			
WATER CONNECTION SIZE						
FPT (mm)	19.05					
Coaxial Coil Volume (L)	0.22	0.30	0.34	0.54	0.91	
VERTICAL CABINET						
Refrigeration Charge (kg)	0.43	0.51	0.54	0.79	0.82	1.05
Air Coil Dimensions (cm) (H x W)	25.4 x 35.6	25.4 x 35.6	30.5 x 41.9	40.6 x 41.9	50.8 x 41.9	50.8 x 41.9
Standard Filter - 2.5 cm Throwaway (cm) (L x H)	25.4 x 40.6	25.4x40.6	40.6 x 50.8	40.6 x 50.8	50.8 x 50.8	50.8 x 50.8
Weight - Operating (kg)	47	48	56	79	81	87
Weight - Shipping (kg)	59	60	69	91	93	99
HORIZONTAL CABINET						
Refrigeration Charge (g)	539	539	539	822	822	1049
Air Coil Dimensions (cm) (H x W)	25.4 x 35.6	25.4 x 35.6	30.5 x 41.9	40.6 x 41.9	40.6 x 52.1	40.6 x 52.1
Standard Filter - 2.5 cm Throwaway (cm) (L x H)	25.4 x 40.6	25.4 x 40.6	40.6 x 50.8	40.6 x 50.8	40.6 x 63.5	40.6 x 63.5
Weight - Operating (kg)	45	48	62	79	82	86
Weight - Shipping (kg)	60	61	72	94	96	102
50PCH,PCV UNIT	036	042	048	060	070	
COMPRESSOR (1 each)	Reciprocating			Scroll		
Maximum Water Working Pressure (kPa)	2758					
PSC FAN MOTOR AND BLOWER						
Fan Motor Type/Speeds	PSC/3					
Fan Motor (W)	373			559		
Blower Wheel Size (Dia x W) (mm)	228.6 x 177.8	254 x 203.2		279.4 x 228.6		
WATER CONNECTION SIZE						
FPT (mm)	19.05			25.4		
Coaxial Coil Volume (L)	1.04		1.85	2.33		
VERTICAL CABINET						
Refrigeration Charge (kg)	1.36	1.36	1.47	1.67	20.7	
Air Coil Dimensions (cm) (H x W)	61.0 x 51.4	61.0 x 51.4	61.0 x 68.0	61.0 x 68.0	81.3 x 68.0	
Standard Filter - 2.5 cm Throwaway (cm) (L x H)	61.0 x 61.0	61.0 x 61.0	61.0 x 76.2	61.0 x 76.2	40.6 x 76.2 (2)	
Weight - Operating (kg)	104	108	130	140	153	
Weight - Shipping (kg)	116	120	142	150	164	
HORIZONTAL CABINET						
Refrigeration Charge (g)	1304	1219	1247	1814	1729	
Air Coil Dimensions (cm) (H x W)	45.7 x 69.9		50.8 x 81.3		50.8 x 106.7	
Standard Filter - 2.5 cm Throwaway (cm) (L x H)	45.7 x 76.2		50.8 x 87.6		50.8 x 60.9 (2)	
Weight - Operating (kg)	103	105	124	131	143	
Weight - Shipping (kg)	123	120	136	144	166	

LEGEND

FPT — Female Pipe Thread
PSC — Permanent Split Capacitor

Table 3 — Physical Data — 50PCH,PCV (009-070) Units CE Rated

50PCH,PCV UNIT	009	012	015	018	024	030
COMPRESSOR (1 each)	Rotary	Rotary	Rotary	Reciprocating	Reciprocating	Reciprocating
Maximum Water Working Pressure (kPa)	2758	2758	2758	2758	2758	2758
PSC FAN MOTOR AND BLOWER						
Fan Motor Type/Speeds	PSC/3	PSC/3	ECM	ECM	ECM	ECM
Fan Motor (W)	75	75	249	249	249	249
Blower Wheel Size (Dia x W) (mm)	114.3 x 114.3	139.7 x 114.3	228.6 x 177.8	228.6 x 177.8	228.6 x 177.8	228.6 x 177.8
WATER CONNECTION SIZE						
FPT (in.)	3/4	3/4	3/4	3/4	3/4	3/4
Coaxial Coil Volume (L)	0.22	0.30	0.34	0.54	0.54	0.91
VERTICAL CABINET						
Refrigeration Charge (kg)	0.43	0.51	0.54	0.79	0.82	1.05
Air Coil Dimensions (cm) (H x W)	25.4 x 35.6	25.4 x 35.6	30.5 x 41.9	40.6 x 41.9	50.8 x 41.9	50.8 x 41.9
Standard Filter - 2.5 cm Throwaway (cm) (L x H)	25.4 x 40.6	25.4 x 40.6	40.6 x 50.8	40.6 x 50.8	50.8 x 50.8	50.8 x 50.8
Weight - Operating (kg)	47	48	56	79	81	87
Weight - Shipping (kg)	59	60	69	91	93	99
HORIZONTAL CABINET						
Refrigeration Charge (kg)	0.54	0.54	0.54	0.82	0.82	1.05
Air Coil Dimensions (cm) (H x W)	25.4 x 35.6	25.4 x 35.6	30.5 x 41.9	40.6 x 41.9	40.6 x 52.1	40.6 x 52.1
Standard Filter - 2.5 cm Throwaway (cm) (L x H)	25.4 x 40.6	25.4 x 40.6	40.6 x 50.8	40.6 x 50.8	40.6 x 63.5	40.6 x 63.5
Weight - Operating (kg)	45	48	62	79	82	86
Weight - Shipping (kg)	60	61	72	95	96	102

50PCH,PCV UNIT	036	042	048	060	070
COMPRESSOR (1 each)	Reciprocating	Reciprocating	Scroll	Scroll	Scroll
Maximum Water Working Pressure (kPa)	2758	2758	2758	2758	2758
PSC FAN MOTOR AND BLOWER					
Fan Motor Type/Speeds	ECM	ECM	ECM	ECM	ECM
Fan Motor (W)	373	373	559	559	559
Blower Wheel Size (Dia x W) (mm)	228.6 x 177.8	254 x 203.2	254 x 203.2	279.4 x 228.6	279.4 x 228.6
WATER CONNECTION SIZE					
FPT (in.)	3/4	3/4	1	1	1
Coaxial Coil Volume (L)	1.04	1.04	1.85	2.33	2.33
VERTICAL CABINET					
Refrigeration Charge (kg)	1.36	1.36	1.47	1.67	2.07
Air Coil Dimensions (cm) (H x W)	61.0 x 51.4	61.0 x 51.4	61.0 x 68.0	61.0 x 68.0	81.3 x 68.0
Standard Filter - 2.5 cm Throwaway (cm) (L x H)	61.0 x 61.0	61.0 x 61.0	61.0 x 76.2	61.0 x 76.2	40.6 x 76.2 (2)
Weight - Operating (kg)	104	108	130	140	153
Weight - Shipping (kg)	116	120	142	150	164
HORIZONTAL CABINET					
Refrigeration Charge (kg)	1.30	1.22	1.25	1.81	1.73
Air Coil Dimensions (cm) (H x W)	45.7 x 69.9	45.7 x 69.9	50.8 x 81.3	50.8 x 81.3	50.8 x 106.7
Standard Filter - 2.5 cm Throwaway (cm) (L x H)	45.7 x 76.2	45.7 x 76.2	50.8 x 87.6	50.8 x 87.6	50.8 x 61.0 (2)
Weight - Operating (kg)	103	105	125	131	144
Weight - Shipping (kg)	123	120	136	145	166

LEGEND

- ECM** — Electronically Commutated Motor
- FPT** — Female Pipe Thread
- PSC** — Permanent Split Capacitor

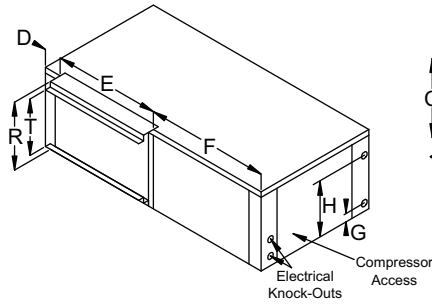

Left Hand Return End Blow

NOTE: Models 048 and 060 Left Hand Return units have condenser water connections on the front right and electrical knockouts on the front left.

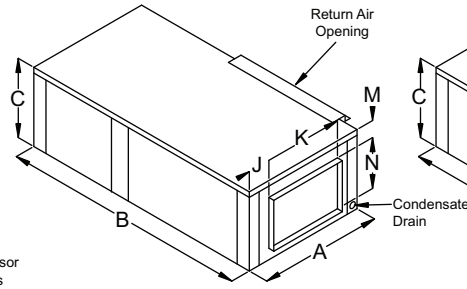

Left Hand Return Straight Through

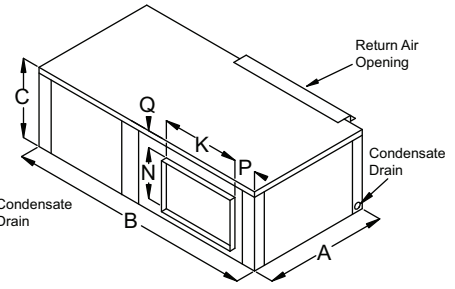

Right Hand Return End Blow

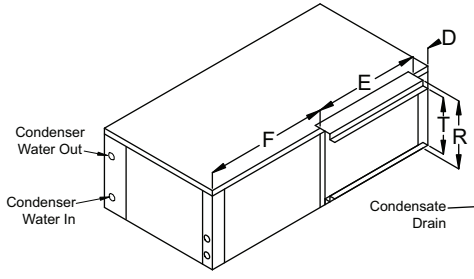

Right Hand Return Straight Through

Service Clearances

LEGEND
R/A — Return Air

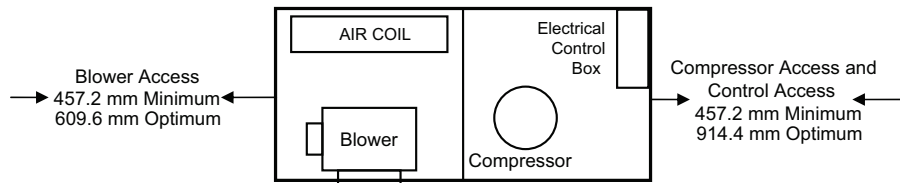

50PCH UNIT SIZE	A	B	C	D	E	F	G	H	J	K	M	N	P	Q	R	T	CONDENSER WATER CONNECTIONS FPT (in.)	RECOMMENDED REPLACEMENT NOMINAL FILTER SIZE
	WIDTH	DEPTH	HEIGHT	CAB END TO FILTER RACK	R/A DUCT WIDTH	CAB FRONT TO FILTER RACK	WATER INLET	WATER OUTLET	SIDE TO DISC. WIDTH	DISC. WIDTH	TOP TO DISC.	DISC. HEIGHT	END TO DISC.	TOP TO DISC.	FILTER RACK HEIGHT	R/A DUCT FLANGE HEIGHT		
009	482.5	838.2	292.1	38.1	410.2	389.9	60.5	241.3	136.5	160.0	151.6	104.1	123.8	35.8	287.0	218.4	3/4	254x406.4x25.4
012	482.5	838.2	292.1	38.1	410.2	389.9	60.5	241.3	133.3	163.3	160.3	104.1	120.6	28.9	287.0	218.4	3/4	254x406.4x25.4
015	558.8	1092.2	431.8	38.1	511.8	542.3	72.6	381.0	207.0	163.3	242.6	104.1	194.3	86.3	426.7	381.0	3/4	406.4x508x25.4
018	558.8	1092.2	431.8	38.1	511.8	542.3	72.6	358.9	137.7	231.9	155.2	245.1	124.9	31.2	426.7	381.0	3/4	406.4x508x25.4
024	558.8	1092.2	431.8	38.1	635.0	419.1	72.6	358.9	137.7	231.9	155.2	245.1	124.9	31.2	426.7	381.0	3/4	406.4x635x25.4
030	558.8	1092.2	431.8	38.1	635.0	419.1	62.7	381.0	137.7	231.9	155.2	245.1	124.9	31.2	426.7	381.0	3/4	406.4x635x25.4
036	558.8	1384.3	482.6	38.1	765.8	580.4	72.6	409.7	164.3	231.9	190.5	261.1	151.6	30.7	477.5	431.8	3/4	457.2x762x25.4
042	558.8	1384.3	482.6	38.1	765.8	580.4	72.6	409.7	133.9	265.4	164.1	287.0	121.1	30.9	477.5	431.8	3/4	457.2x762x25.4
048	635.0	1384.3	533.4	38.1	878.8	467.4	72.6	470.4	184.1	265.4	189.5	288.5	171.5	54.8	528.3	482.6	1	508x876.3x25.4
060	635.0	1384.3	533.4	38.1	878.8	467.4	72.6	470.4	160.5	298.7	172.9	317.5	147.8	42.6	528.3	482.6	1	508x876.3x25.4
070	635.0	1651.0	533.4	38.1	1221.7	391.1	72.6	470.4	160.5	298.7	172.9	317.5	147.8	42.6	528.3	482.6	1	508x609.6x25.4 (2)

NOTES:

- All dimensions are metric (mm) unless stated otherwise.
- All condensate drain connections are 3/4 in. FPT.
- Specifications subject to change without notice.
- The 25.4 mm filter rack extends 31.24 mm beyond the side of the unit. The 50.8 mm filter rack extends 73.4 mm beyond the side of the unit. The 50.8 mm filter rack is 4-sided with a filter access door on one end and can accept either a 25.4 mm or 50.8 mm filter.

Fig. 1 — 50PCH009-070 Unit Dimensions

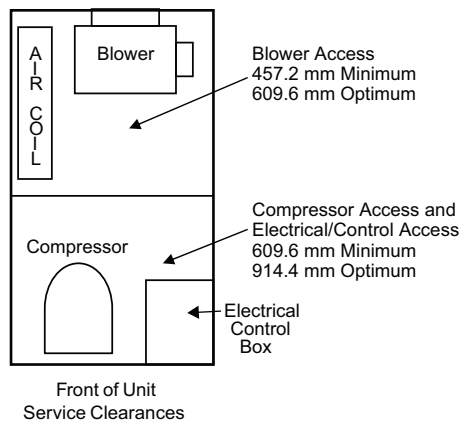
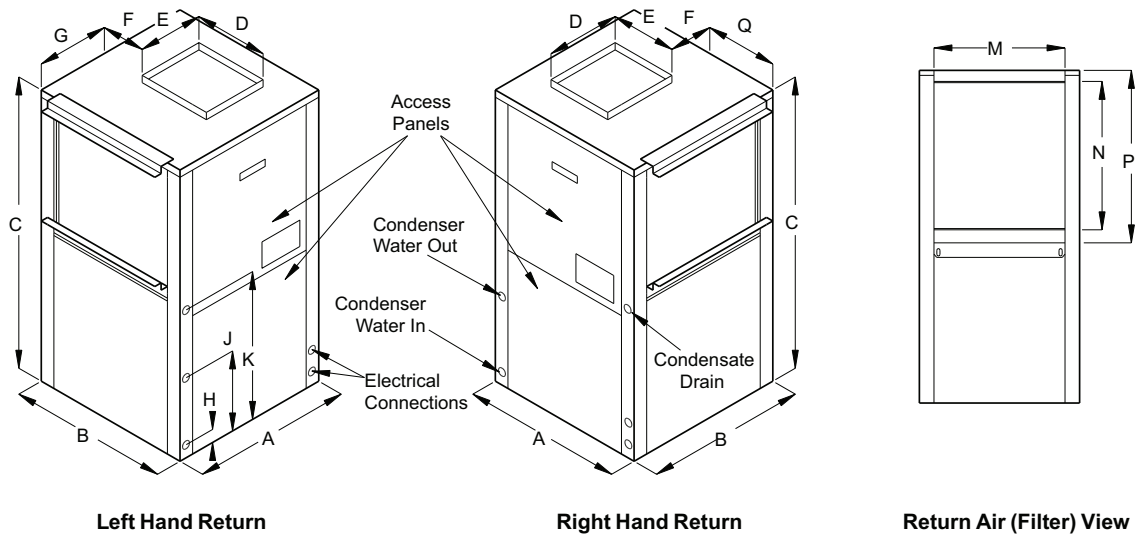

LEGEND
R/A — Return Air

50PCV009-070 UNITS

50PCV UNIT SIZE	A	B	C	D	E	F	G	H	J	K	M	N	P	Q	CONDENSER WATER CONNECTIONS FPT (in.)	RECOMMENDED REPLACEMENT FILTER SIZE
	WIDTH	DEPTH	HEIGHT	DISC. DEPTH	DISC. WIDTH	CABINET EDGE TO DISC.	LEFT SIDE TO DISC.	WATER INLET	WATER OUTLET	CONDENSATE DRAIN	R/A DUCT WIDTH	R/A DUCT FLANGE HEIGHT	FILTER RACK HEIGHT			
009	482.6	482.6	615.95	254.0	203.2	114.3	236.2	61.98	245.87	352.30	406.4	203.2	254.0	137.2	3/4	254x406.4x25.4
012	482.6	482.6	615.95	254.0	203.2	114.3	236.2	61.98	245.87	352.30	406.4	203.2	254.0	137.2	3/4	254x406.4x25.4
015	546.1	546.1	819.15	254.0	203.2	147.3	254.0	72.39	214.63	403.10	508.0	355.6	406.4	88.9	3/4	406.4x508x25.4
018	546.1	546.1	819.15	355.6	355.6	78.7	132.1	72.39	214.63	403.10	508.0	355.6	406.4	132.1	3/4	406.4x508x25.4
024	546.1	546.1	996.95	355.6	355.6	78.7	132.1	71.12	214.63	479.30	508.0	457.2	508.0	132.1	3/4	508x508x25.4
030	546.1	546.1	996.95	355.6	355.6	78.7	132.1	71.12	214.63	479.30	508.0	457.2	508.0	132.1	3/4	508x508x25.4
036	546.1	660.4	1098.55	406.4	355.6	101.6	127.0	69.85	273.56	479.30	609.6	558.8	609.6	127.0	3/4	609.6x609.6x25.4
042	546.1	660.4	1098.55	406.4	355.6	101.6	127.0	69.85	273.56	479.30	609.6	558.8	609.6	127.0	3/4	609.6x609.6x25.4
048	609.6	825.5	1149.35	457.2	355.6	177.8	157.5	82.80	335.28	530.10	762.0	558.8	609.6	157.5	1	609.6x762x25.4
060	609.6	825.5	1149.35	457.2	355.6	177.8	157.5	82.80	335.28	530.10	762.0	558.8	609.6	157.5	1	609.6x762x25.4
070	660.4	844.6	1479.55	457.2	406.4	198.1	182.9	74.17	339.34	657.10	762.0	762.0	812.8	182.9	1	406.4x762x25.4 (2)

NOTES:

1. All dimensions are metric (mm) unless stated otherwise.
2. All condensate drain connections are 3/4 in. FPT.
3. Specifications subject to change without notice.

4. The 25.4 mm filter rack extends 31.24 mm beyond the side of the unit. The 50.8 mm filter rack extends 73.4 mm beyond the side of the unit. The 50.8 mm filter rack is 4-sided with a filter access door on one end and can accept either a 25.4 mm or 50.8 mm filter.

Fig. 2 — 50PCV009-070 Unit Dimensions

Table 4 — 50PCH009-070 Corner Weights (kg)

UNIT SIZE	TOTAL (kg)	LEFT HAND EVAPORATOR				RIGHT HAND EVAPORATOR			
		LEFT FRONT*	RIGHT FRONT*	LEFT BACK	RIGHT BACK	LEFT FRONT*	RIGHT FRONT*	LEFT BACK	RIGHT BACK
009	47	13	10	12	11	10	13	11	12
012	48	13	11	12	12	11	13	12	12
015	58	16	13	15	13	13	16	13	15
018	80	26	16	22	17	16	26	17	22
024	82	26	17	22	17	17	26	17	22
030	88	28	18	23	19	18	28	19	23
036	108	32	22	30	24	22	32	24	30
042	105	32	21	29	23	21	32	23	29
048	122	39	27	28	27	27	39	27	28
060	131	40	29	31	30	29	40	30	31
070	143	44	32	35	32	32	44	32	35

* Front is counter box end.

Step 3 — Locate Unit — Locate the unit in an indoor area that allows easy removal of the filter and access panels, and has enough room for service personnel to perform maintenance or repair. Provide sufficient room to make fluid, electrical, and duct connection(s). If the unit is located in a confined space such as a closet, provisions must be made for return air to freely enter the space.

50PCH — Unit condensate drains are not internally trapped. Allow room below the unit base for horizontal and counterflow models for an adequate condensate trap.

These units are not approved for outdoor installation; therefore, they must be installed inside the structure being conditioned. Do not locate units in areas that are subject to freezing. Units must be installed in conditioned space that is not subject to extremes of temperature or humidity to avoid cabinet sweating and/or equipment damage.

Do not use units for temporary heating, air conditioning or ventilation during construction, especially when plastering, sanding or painting. Care should be taken to avoid introduction of dust, paint or debris into the air coil.

Step 4 — Mount the Unit

DUCT FLANGES — The 50PC heat pumps feature fold-out return and supply air duct flanges. These fold-out flanges allow the heat pumps to more easily fit through doorways and other tight spaces, and also prevent damage in shipping and handling.

It is recommended that all fold-out flanges be folded out once the heat pump is installed to ensure that return and supply airflow is not obstructed. These flanges can be easily folded using standard or duckbill pliers. Once folded out these flanges can be used to support light ductwork loads.

To reduce sound transmission, units should be installed using flexible electrical conduit and hose kits. Care should be taken to ensure that no part of the unit cabinet is touching part of the building structure. For ducted return applications, a flexible duct connection should be used.

HORIZONTAL UNITS (50PCH) — While horizontal units may be installed on any level surface strong enough to hold their weight, they are typically suspended above a ceiling by threaded rods. The rods are usually attached to the unit corners by hanging bracket kits. See Fig. 3. The rods must be securely anchored to the ceiling.

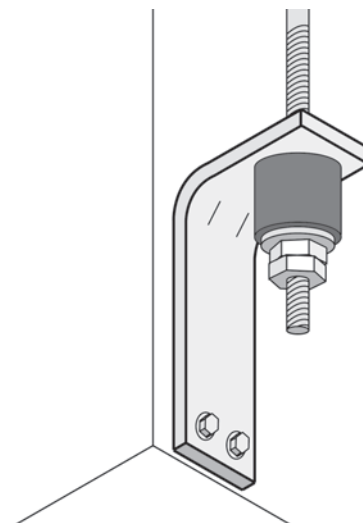

Fig. 3 — Hanger Bracket

Horizontal units installed above the ceiling must conform to all local codes. An auxiliary drain pan if required by code, should be at least 102 mm larger than the bottom of the heat pump.

Plumbing connected to the heat pump must not come in direct contact with joists, trusses, walls, etc. Some applications require an attic floor installation of the horizontal unit. In this case the unit should be set in a full size secondary drain pan on top of a vibration absorbing mesh.

The secondary drain pan prevents possible condensate overflow or water leakage damage to the ceiling. The secondary drain pan is usually placed on a plywood base isolated from the ceiling joists by additional layers of vibration absorbing mesh. In both cases, a 19 mm drain connected to this secondary pan should be run to an eave at a location that will be noticeable.

⚠ CAUTION
If the unit is located in a crawl space, the bottom of the unit must be at least 101.6 mm above grade to prevent flooding of the electrical parts due to heavy rains.

Hanging Bracket Assembly — All horizontal units come with a hanging bracket kit to facilitate suspended unit mounting using threaded rod. Hanging brackets are to be installed as shown in Fig. 4.

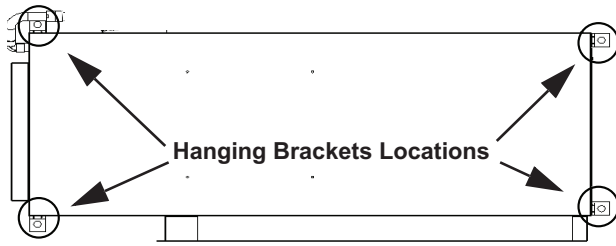

Fig. 4 — Hanging Bracket Locations

This kit includes the following:

- (5) Brackets
- (5) Rubber vibration isolators
- (8) Screws #10 x 1/2 in.
- (10) Bolts 1/4 - 28 x 1/2 in. hex bolt (not used on this model)

The following are needed and are to be field provided:

- Threaded rod (3/8 in. max dia)
 - Hex Nuts
 - Washers (1 3/4 in. min OD)
1. Remove and discard factory-provided screws from location where hanging brackets will be installed as shown in Fig. 5.

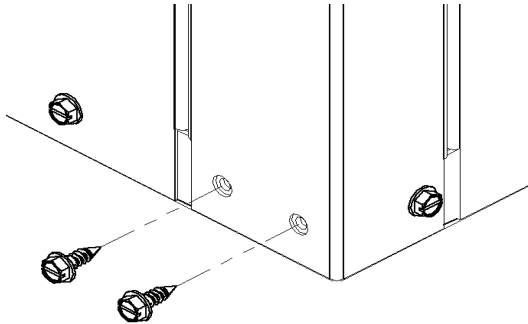

Fig. 5 — Remove Factory-Provided Screws

2. Mount four brackets to unit corner post using the bolts provided in the kit as shown in Fig. 6.

⚠ WARNING

To avoid possible injury or death due to faulty installation do not reuse screws removed from the unit on Step 1 to mount the hanging brackets to the unit.

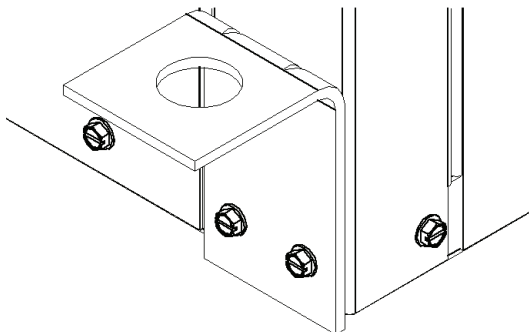

Fig. 6 — Bracket Mounting

⚠ WARNING

To avoid possible injury or death due to faulty installation follow all applicable code requirements when hanging this unit.

3. Install rubber grommet on the bracket as shown in Fig. 7.
4. Hang the unit and assemble the field provided thread rod, nuts and washers on to the brackets as shown in Fig. 7.

⚠ WARNING

To avoid possible injury or death due to faulty installation rods must be securely anchored to the ceiling.

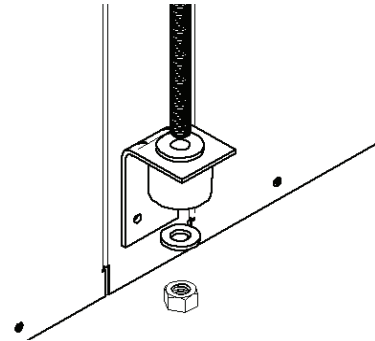

Fig. 7 — Unit Hanging

VERTICAL UNITS (50PCV) — Vertical units should be mounted level on a vibration absorbing pad slightly larger than the unit base in order to minimize vibration transmission from the unit to the building structure. See Fig. 8. It is generally not necessary to anchor the unit unless required by local code.

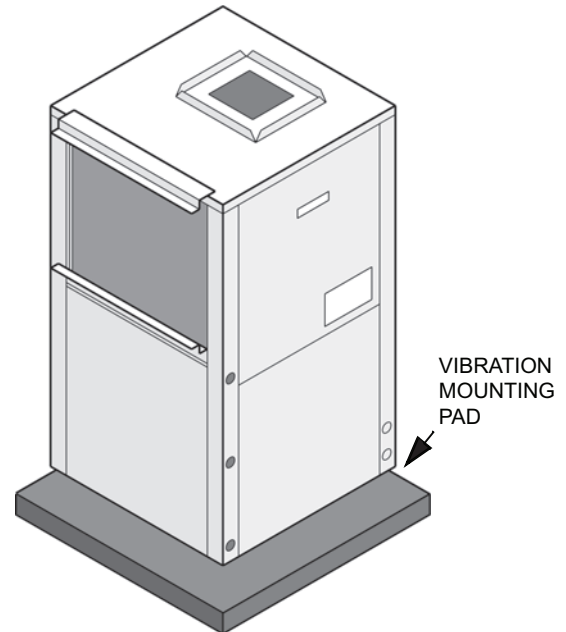

Fig. 8 — Mounting Vertical Units

All major service access for the vertical models is from the front side of the unit. When installing the unit in a confined space such as a closet, ensure that the service panel screws are accessible, that the filter can be replaced without damage and that water and electrical connections are accessible. For models with a unit-mounted disconnect switch, make sure the switch can be easily seen and operated.

To reduce sound transmission, units should be installed using flexible electrical conduit and hose kits. Care should be taken to ensure that no part of the unit cabinet is touching part of the building structure. For ducted return applications, a flexible duct connection should be used.

Step 5 — Check Duct System — All units are provided with a return air duct flange and supply air duct connections. Refer to unit dimensional drawings (Fig. 1 and 2) for physical dimensions of the collar and flange.

A flexible connector is recommended for supply and return air duct connections on metal duct systems. All metal ducting should be insulated with a minimum of 25 mm duct insulation to avoid heat loss or gain and prevent condensate from forming during the cooling operation. Application of the unit to uninsulated ductwork is not recommended as the unit's performance will be adversely affected.

If the unit will be installed in a new installation with new ductwork, the installation should be designed using current ASHRAE (American Society of Heating, Refrigerating, and Air-Conditioning Engineers) procedures for duct sizing. If the unit will be connected to an existing duct system, a check should be made to assure that the duct system has the capacity to handle the air required for the unit application. If the duct system is too small, larger ductwork must be installed. Be certain to check for and repair existing leaks and repair. The duct system and all diffusers should be sized to handle the designed airflow quietly. To maximize sound attenuation of the unit blower, the supply and return air plenums should be insulated. There should be no direct straight air path through the air grille into the heat pump. The return air inlet to the heat pump must have at least one 90-degree turn away from the space return air grille. If air noise or excessive airflow are a problem, the blower speed can be changed to a lower speed to reduce airflow.

HORIZONTAL SUPPLY AIR CONFIGURATION CONVERSION — The supply air location on horizontal units can be quickly field converted from end blow to straight through or vice-versa. To convert the supply air direction, follow the steps below:

1. If connected to power, shut off the unit and disconnect switch or circuit breaker.
2. Unscrew and remove the blower access panel.
3. Disconnect the wires from the unit electrical box to the blower motor. Note which speed taps are wired for units.
4. Unscrew and carefully remove the blower panel with the blower and motor attached. Be careful not to damage the refrigerant coils or any other internal unit components.
5. Remove the blower support brackets from the bottom of the blower housing and relocate them to the top of the blower housing.
6. Turn the blower panel 180 degrees so that the blower support brackets are now at the bottom of the blower.
7. Insert the blower panel with the blower and motor into the desired location. Be careful not to damage the refrigerant coils or any other internal unit components. Screw the panel into place.
8. Replace the wires between the blower motor and electrical box. Make sure to connect wires to the proper speed taps.
9. Replace the blower access panel.
10. Reconnect power to the unit.

Step 6 — Install Condensate Drain — A drain line must be connected to the heat pump and pitched away from the unit a minimum of 2 cm/m to allow the condensate to flow away from the unit.

This connection must be in conformance with local plumbing codes. A trap must be installed in the condensate line to ensure free condensate flow. (Heat pumps are not internally

trapped.) A vertical air vent is sometimes required to avoid air pockets. See Fig. 9.

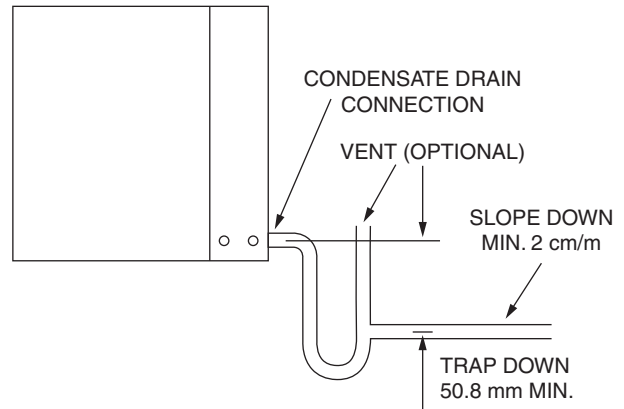

Fig. 9 — Condensate Drain

The depth of the trap depends on the amount of positive or negative pressure on the drain pan. A second trap must not be included. The horizontal unit should be pitched approximately 6 mm towards the drain in both directions, to facilitate condensate removal. (See Fig. 10.)

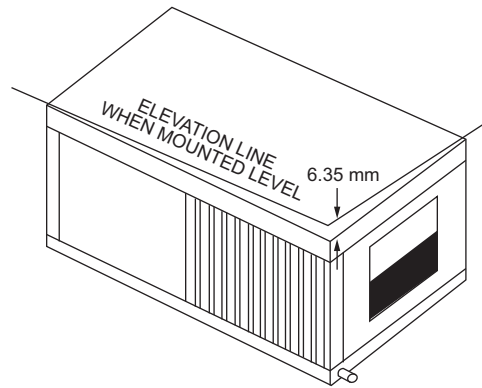

Fig. 10 — Pitched Unit

Step 7 — Pipe Connections — Depending on the application, there are 3 types of WSHP piping systems to choose from: water loop, ground-water and ground loop. Refer to Piping Section of Carrier System Design Manual for additional information.

All WSHP units use low temperature soldered female pipe thread fittings for water connections to prevent annealing and out-of-round leak problems which are typically associated with high temperature brazed connections. Refer to Tables 2 and 3 for connection sizes. When making piping connections, consider the following:

- Use a backup wrench when making screw connections to unit to prevent internal damage to piping.
- Insulation may be required on piping to avoid condensation in the case where fluid in loop piping operates at temperatures below dew point of adjacent air.
- Piping systems that contain steel pipes or fittings may be subject to galvanic corrosion. Dielectric fittings may be used to isolate the steel parts of the system to avoid galvanic corrosion.

PIPING — Supply and return piping must be as large as the unit connections on the heat pump (larger on long runs). Never use flexible hoses of a smaller inside diameter than that of the water connections on the unit. The 50PC units are supplied with either a copper or optional cupro-nickel condenser. Copper is adequate for ground water that is not high in mineral content. Refer to water quality guidelines.

In conditions anticipating moderate scale formation or in brackish water a cupro-nickel heat exchanger is recommended. Both the supply and discharge water lines will sweat if subjected to low water temperature. These lines should be insulated to prevent damage from condensation.

All manual flow valves used in the system must be ball valves. Globe and gate valves must not be used due to high pressure drop and poor throttling characteristics. Always check carefully for water leaks and repair appropriately. Units are equipped with female pipe thread fittings. Consult the specification sheets for sizes.

Teflon¹ tape sealer should be used when connecting water piping connections to the units to ensure against leaks and possible heat exchanger fouling. Do not overtighten the connections. Flexible hoses should be used between the unit and the rigid system to avoid possible vibration. Ball valves should be installed in the supply and return lines for unit isolation and unit water flow balancing.

Pressure/temperature ports are recommended in both the supply and return lines for system flow balancing. The water flow can be accurately set by measuring the water-to-refrigerant heat exchangers water side pressure drop. See the unit specification sheets for the water flow and pressure drop information.

WATER LOOP APPLICATIONS — Water loop applications usually include a number of units plumbed to a common piping system. Maintenance to any of these units can introduce air into the piping system. Therefore, air elimination equipment comprises a major portion of the mechanical room plumbing.

For proper maintenance and servicing, pressure-temperature (P/T) ports are necessary for temperature and flow verification.

In addition to complying with any applicable codes, consider the following for system piping:

- Piping systems using water temperatures below 10°C require 12.7 mm closed cell insulation on all piping surfaces to eliminate condensation.
- Avoid all plastic to metal threaded fittings due to the potential to leak. Use a flange fitted substitute.
- Teflon tape thread sealant is recommended to minimize internal fouling of the heat exchanger.
- Use backup wrench. Do not overtighten connections.
- Route piping to avoid service access areas to unit.
- Flush the piping system prior to operation to remove dirt and foreign materials from the system.

To assure adequate cooling and heating performance, the cooling tower and boiler water loop temperature should be maintained between 10°C and 23.9°C in the heating mode and 15.6°C and 43.3°C in the cooling mode. In the cooling mode, heat is rejected from the unit into the water loop. A cooling tower provides evaporative cooling to the loop fluid, thus maintaining a constant supply temperature to the unit. When

utilizing an open cooling tower, chemical water treatment is mandatory to ensure the water is free of corrosive materials.

A secondary heat exchanger (plate frame between the unit and the open cooling tower) may also be used. In the heating mode, heat is absorbed from the water loop to the unit. A boiler can be utilized to maintain the loop within the proper temperature range.

No unit should be connected to the supply or return piping until the water system has been completely cleaned and flushed to remove dirt, piping chips or other foreign material. Supply and return hoses should be connected together during this process to ensure the entire system is properly flushed. After the cleaning and flushing has taken place the unit may be connected to the water loop and should have all valves wide open. See Fig. 11.

NOTE: It is imperative that all air is eliminated from the closed loop side of the heat exchanger to prevent condenser fouling.

GROUND-LOOP APPLICATIONS — In addition to complying with any applicable codes, consider the following for system piping:

- Limit piping materials to only polyethylene fusion in the buried sections of the loop.
- Do not use galvanized or steel fittings at any time due to corrosion.
- Avoid all plastic to metal threaded fittings due to the potential to leak. Use a flange fitted substitute.
- Do not overtighten connections.
- Route piping to avoid service access areas to unit.
- Use pressure-temperature (P/T) plugs to measure flow of pressure drop.

GEOHERMAL CLOSED LOOP SYSTEMS — Operation of a 50PC Series unit on a closed loop application requires the extended range option.

NOTE: Closed loop and pond applications require specialized design knowledge. No attempt at these installations should be made unless the dealer has received specialized training.

Utilizing Ground Loop Pumping Package (GLP) makes the installation easy. Anti-freeze solutions must be utilized when low loop temperatures are expected to occur. Refer to the installation manuals for more specific instructions. See Fig. 12.

OPEN WELL WATER SYSTEMS — When a water well is used exclusively for supplying water to the heat pump, the pump should operate only when the heat pump operates. A 24-volt, double pole single throw (DP/ST) contactor can be used to operate the well pump with the heat pump. When two or more units are supplied from one well, the pump can be wired to operate independently from either unit. Two 24-volt double pole single throw relays wired in parallel are required.

The discharge water from the heat pump is not contaminated in any manner and can be disposed of in various ways depending on local codes (i.e., discharge well, dry well, storm sewer, drain field, stream, pond, etc.). See Fig. 13.

1. Teflon is a registered trademarks of DuPont.

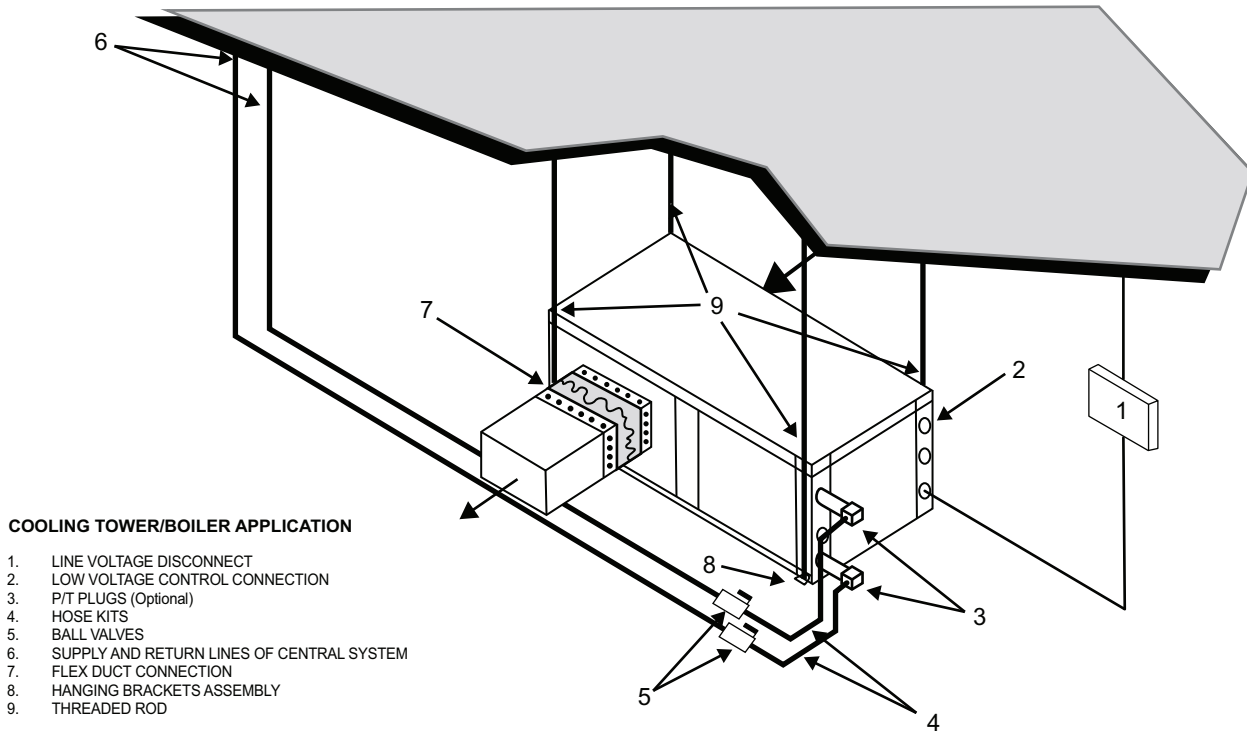

Fig. 11 — Cooling/Boiler Application

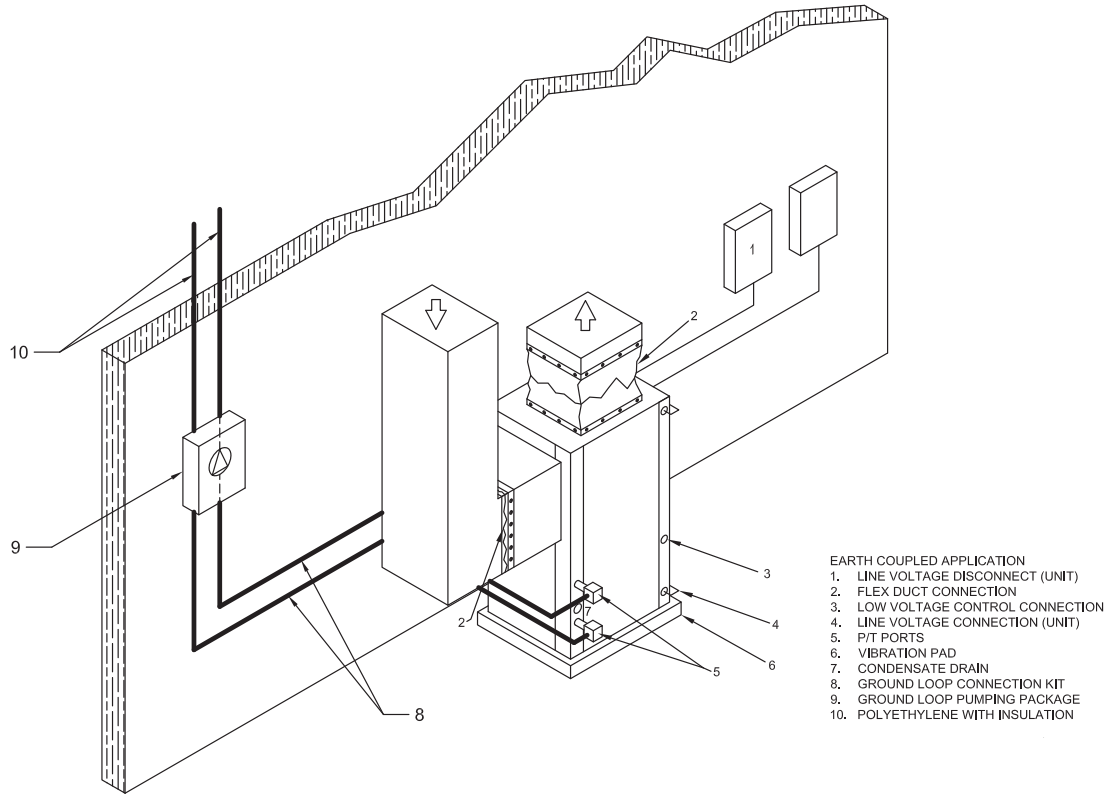
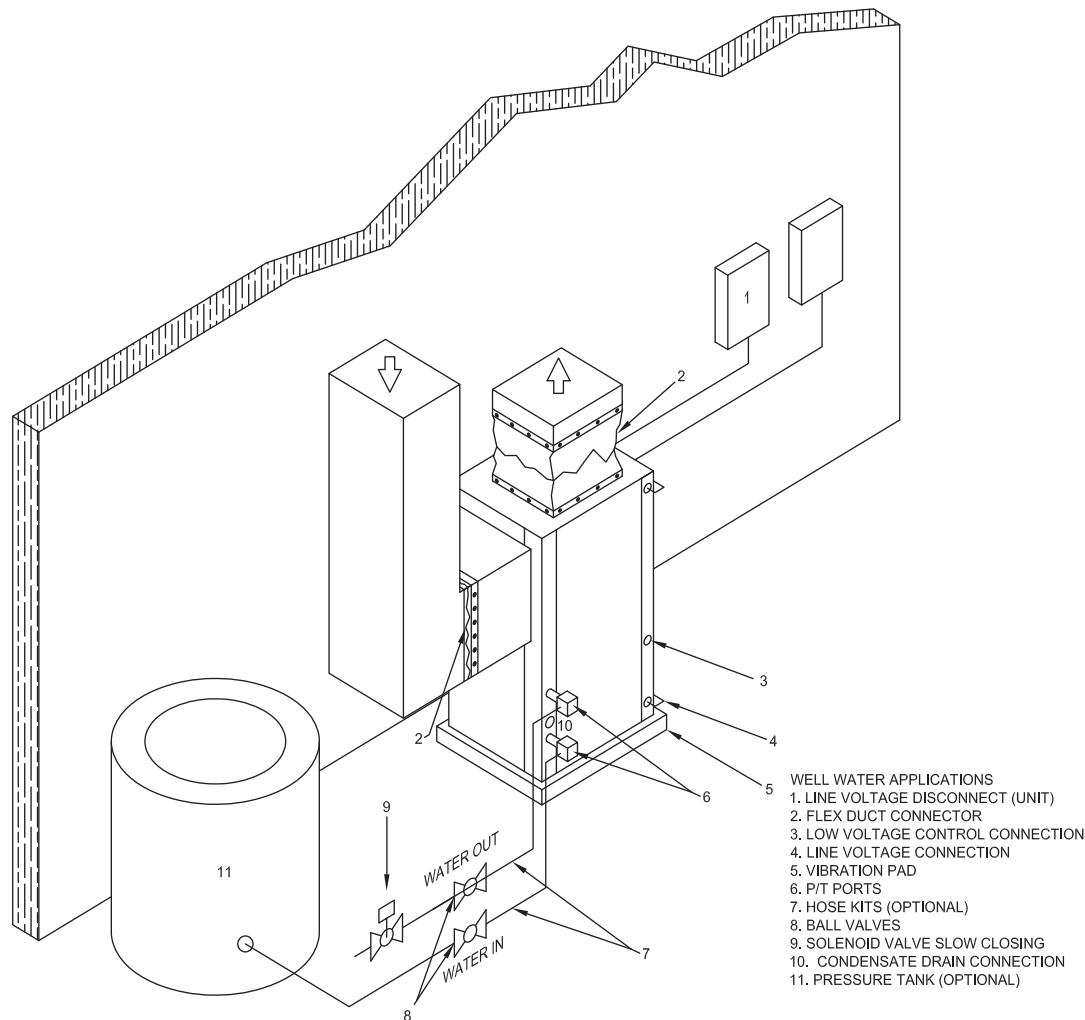

Fig. 12 — Earth Coupled Application



- WELL WATER APPLICATIONS
1. LINE VOLTAGE DISCONNECT (UNIT)
 2. FLEX DUCT CONNECTOR
 3. LOW VOLTAGE CONTROL CONNECTION
 4. LINE VOLTAGE CONNECTION
 5. VIBRATION PAD
 6. P/T PORTS
 7. HOSE KITS (OPTIONAL)
 8. BALL VALVES
 9. SOLENOID VALVE SLOW CLOSING
 10. CONDENSATE DRAIN CONNECTION
 11. PRESSURE TANK (OPTIONAL)

Fig. 13 — Well Water Applications

INSTALLATION OF SUPPLY AND RETURN HOSE KIT — Follow these piping guidelines:

1. Install a drain valve at the base of each supply and return riser to facilitate system flushing.
2. Install shutoff/balancing valves and unions at each unit to permit unit removal for servicing.
3. Place strainers at the inlet of each system circulating pump.
4. Select the proper hose length to allow slack between connection points. Hoses may vary in length by +2% to -4% under pressure.
5. Refer to Table 5. Do not exceed the minimum bend radius for the hose selected. Exceeding the minimum bend radius may cause the hose to collapse, which reduces water flow rate. Install an angle adapter to avoid sharp bends in the hose when the radius falls below the required minimum.

NOTE: Piping must comply with all applicable codes.

Table 5 — Metal Hose Minimum Bend Radii

HOSE DIAMETER (mm)	MINIMUM BEND RADI (mm)
12.7	63.5
19.1	101.6
25.4	139.7

Insulation is not required on loop water piping except where the piping runs through unheated areas or outside the building or when the loop water temperature is below the minimum

expected dew point of the pipe ambient. Insulation is required if loop water temperature drops below the dew point.

IMPORTANT: Do not bend or kink supply lines or hoses.

Pipe joint compound is not necessary when Teflon threaded tape is pre-applied to hose assemblies or when flared-end connections are used. If pipe joint compound is preferred, use compound only in small amounts on the male pipe threads of the fitting adapters. Prevent sealant from reaching the flared surfaces of the joint.

NOTE: When anti-freeze is used in the loop, assure that it is compatible with Teflon tape or pipe joint compound employed.

Maximum allowable torque for brass fittings is 40.1 Nm. If a torque wrench is not available, tighten finger-tight plus one quarter turn. Tighten steel fittings as necessary.

Optional pressure-rated hose assemblies designed specifically for use with Carrier units are available. Similar hoses can be obtained from alternate suppliers. Supply and return hoses are fitted with swivel-joint fittings at one end to prevent kinking during installation.

⚠ CAUTION

Backup wrench is required when tightening water connections to prevent water line damage. Failure to use a backup wrench could result in equipment damage.

Male adapters secure hose assemblies to the unit and risers. Install hose assemblies properly and check them regularly to avoid system failure and reduced service life. See Fig. 14.

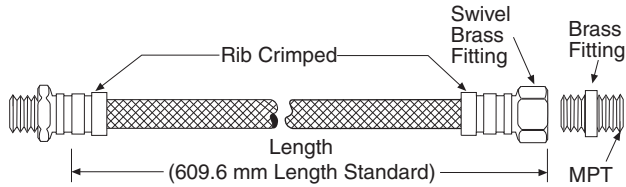

Fig. 14 — Supply/Return Hose Kit

Step 8 — Wire Field Power Supply — See Fig. 15-16 for typical wiring diagrams. See Tables 6-10 for additional electrical data.

⚠ WARNING

To avoid possible injury or death due to electrical shock, open the power supply disconnect switch and secure it in an open position during installation.

⚠ CAUTION

All power connections must be properly torqued to avoid the risk of overheating.

HIGH VOLTAGE — All field installed wiring must comply with the following regulations and requirements:

- The responsible power supply company's local regulations and requirements, including any corresponding special rules
- National building regulations
- EN 60335 (Electrical appliances and similar utilities - Safety)
 - Part 1 (General demands)
 - Part 2-40 (Special demands on electrical heat pumps, air conditioners and air dehumidifiers)
- EN 12828 (Heating systems in buildings - Design and installation of water-based heating systems)

All field wiring should be installed by qualified and trained personnel. Refer to the unit wiring diagram for field connection requirements.

⚠ CAUTION

Operating the unit below the minimum voltage, above the maximum voltage or with incorrect phasing can result in poor system performance or damage to the heat pump.

Power wiring to the heat pump should be enclosed in flexible conduit to minimize the transmission of vibration from the unit cabinet to the building. The power is connected to the line (L) side of the compressor contactor and the ground lug in the unit electrical box.

ELECTRICAL - LOW VOLTAGE — All thermostat wiring is connected to a terminal block located in the unit electrical box. Refer to the unit wiring diagram for connection details.

⚠ WARNING

To avoid possible injury or death due to electrical shock, never route control wiring through the same conduit as power supply wiring.

The 50PC heat pump can be controlled by most commonly available single stage heat pump thermostats. The reversing valve on the 50PC Series unit is energized when the unit is in the cooling mode. Thermostats should be located on an interior wall away from supply ducts. Avoid locations subject to direct sunlight or drafts, or external walls. Thermostat wiring should be 1 mm. Refer to the installation instructions for the thermostat for further details.

IMPORTANT: Exceptionally long runs of thermostat wire should be avoided to prevent voltage drops in the control circuit.

The VA capacity of the transformer should be considered when connecting low voltage accessories to the heat pump such as thermostats or solenoid valves.

Table 6 shows the VA draw of factory-mounted components in the 50PC heat pump. The total VA draw of the heat pump internal components plus any attached accessories must be lower than the VA capacity of the unit control transformer.

⚠ WARNING

Exceeding the transformer capacity can result in low control voltage, erratic unit operation or damage to the heat pump.

Table 6 — Low Voltage VA Draw

STANDARD CONSTRUCTION	
Component	VA
Blower Relay	6-7
Reversing Valve Solenoid	8-9
Compressor Contactor	6-8
Complete C board	2
Total VA draw	22-26

Table 7 — C Board Factory Default Settings

FACTORY DEFAULT SETTINGS	
Temperature	-3.3°C
Lockout	2
Reset	Y
Alarm	Pulse
Test	No

Table 8 — C Board DIP Switch Default Position

DIP SWITCH DEFAULT POSITION			
	Lockout	4	2
	Reset	R	Y
	Alarm	Cont	Pulse
	Test	Yes	No

STATUS LED - BLINK CODES	
1	HIGH PRESSURE FAULT
2	LOW PRESSURE FAULT
3	CONDENSER FREEZE CONDITION
4	CONDENSATE OVERFLOW FAULT
5	BROWNOUT FAULT
6	EVAPORATOR FREEZE CONDITION

FACTORY WIRE ———
FIELD WIRE - - - - -

STANDARD COMPONENTS LEGEND:

- BC — BLOWER MOTOR CAPACITOR
- BM — BLOWER MOTOR
- BR — BLOWER RELAY
- COMP — COMPRESSOR
- CAP — COMPRESSOR CAPACITOR
- CC — COMPRESSOR CONTACTOR
- CS — CONDENSATE SENSOR (IN DRAIN PAN)
- EMS — EMERGENCY SHUTDOWN RELAY
- FS — FREEZE SENSOR
- HPS — HIGH PRESSURE SWITCH
- LPS — LOW PRESSURE SWITCH
- RV — REVERSING VALVE (HEAT PUMPS)

OPTIONAL COMPONENTS LEGEND:

- [] CBR — 24V CIRCUIT BREAKER
- [] DS — DISCONNECT SWITCH
- [] HSL — HIGH TEMP SUCTION LIMIT (WITH HOT GAS BYPASS ONLY)
- [] LWV — LEAVING WATER VALVE
- [] VES — VALVE END SWITCH

NOTES:

1. SEE UNIT NAME PLATE FOR ELECTRICAL RATING.
2. ALL FIELD WIRING MUST BE IN ACCORDANCE WITH N.E.C.—N.F.P.A. #70; COPPER CONDUCTORS ONLY.
3. FOR ALTERNATE EMS COIL VOLTAGES CONSULT FACTORY.
4. COMPLETE BOARD INCLUDES BUILT IN: 270–300 SECOND RANDOM START 300 SECOND DELAY ON BREAK 120 SECOND LOW PRESSURE BYPASS
5. "TEST" DIP SWITCH REDUCES DELAYS TO 10 SEC WHEN SET TO YES. MUST BE SET TO "NO" FOR NORMAL OPERATION.
6. "FREEZE SENSOR" ON CONDENSER WILL OPERATE AT -3.3 C BY DEFAULT. IF -9.4 C OPERATION IS REQUIRED JUMPER R30 MUST BE CUT IF FREEZE SENSOR IS NOT INSTALLED A JUMPER SHALL BE INSTALLED BETWEEN THE FREEZE1 OR FREEZE2 SENSOR TERMINALS.
7. "ALARM OUTPUT" DIP SWITCH MUST BE SET TO "PULSE" IF BLINKING T-STAT SERVICE LIGHT IS DESIRED.
8. DEFAULT SETTINGS FOR BOARD FROM FACTORY SHOWN. ALSO SEE INSTALLATION MANUAL.
9. ALARM OUTPUT IS NORMALLY OPEN (NO) DRY CONTACT. IF 24 VAC IS NEEDED, CONNECT R TO ALR-COM TERMINAL. 24VAC WILL BE SENSED ON THE ALR-OUT WHEN THE UNIT IS IN ALARM CONDITION. OUTPUT WILL BE PULSED IF PULSE IS SELECTED.
10. FACTORY MOUNTED LOOP PUMP OR TWO WAY WATER VALVE. BOTH DEVICES WILL NOT BE PRESENT IN THE SAME UNIT.

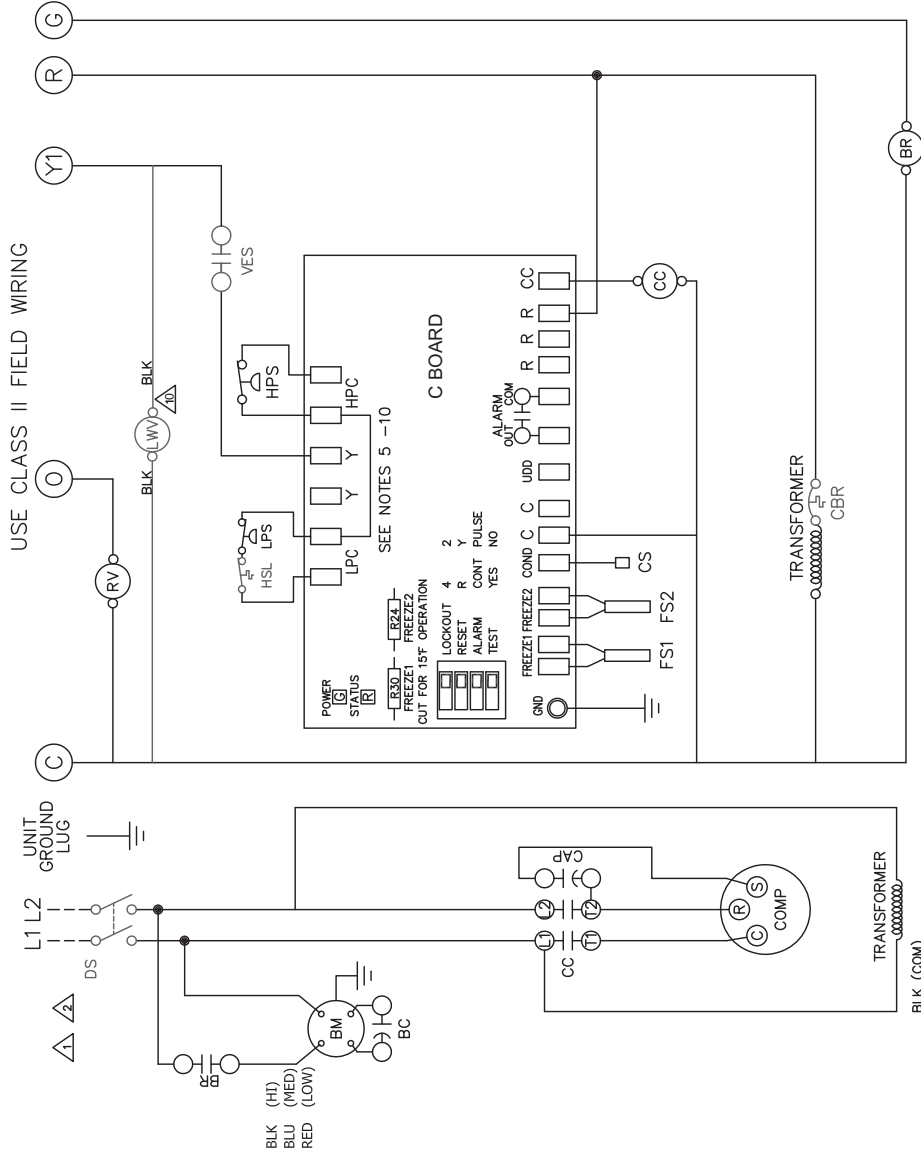
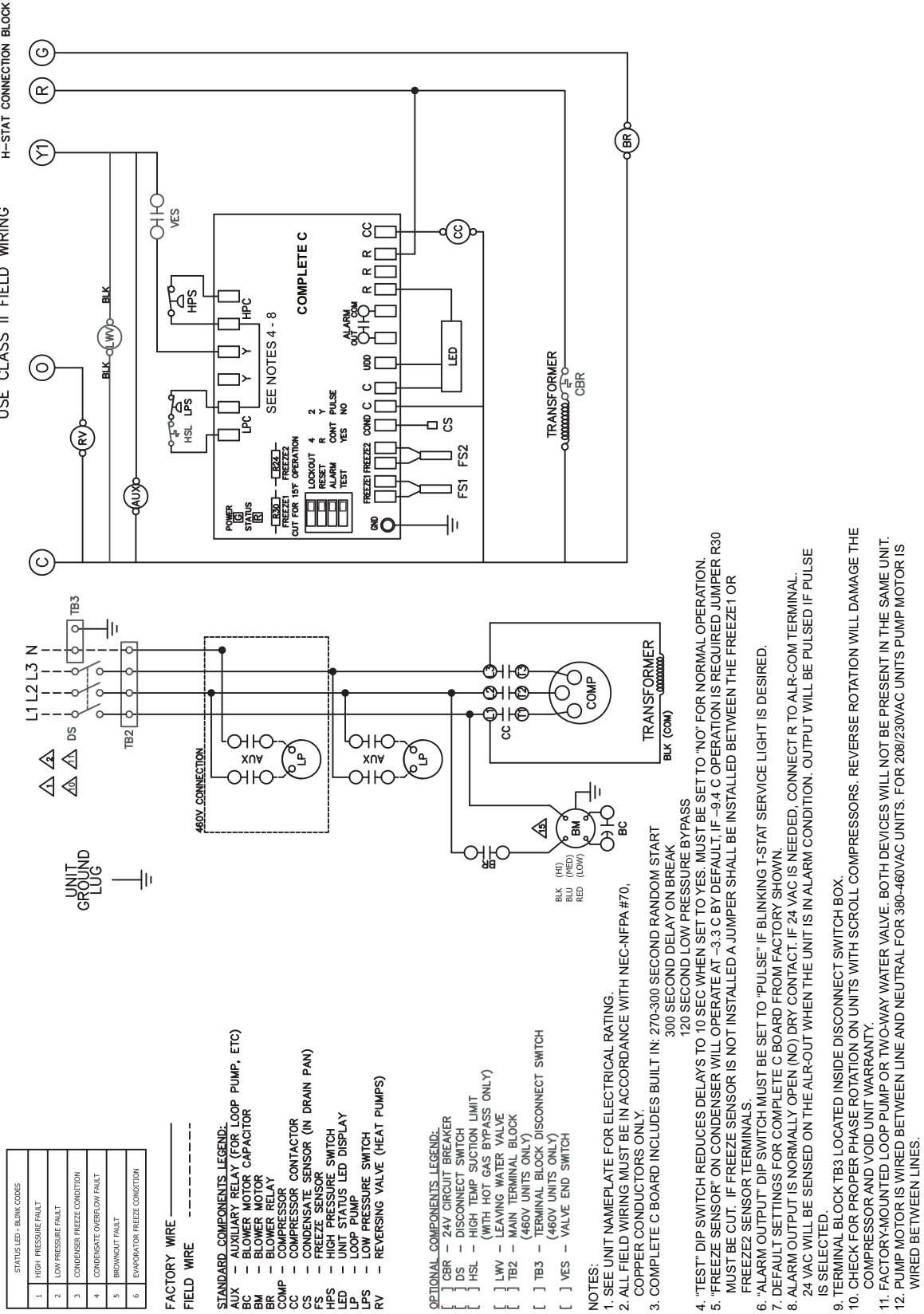

Fig. 15 — PSC Motor, Single Phase/Single Stage, Sizes 009 to 036



STATUS LED - BLINK CODES
1. HIGH PRESSURE FAULT
2. LOW PRESSURE FAULT
3. CONDENSER FREEZE CONDITION
4. CONDENSATE OVERFLOW FAULT
5. BROWNOUT FAULT
6. EVAPORATOR FREEZE CONDITION

FACTORY WIRE ———
FIELD WIRE - - - - -

STANDARD COMPONENTS LEGEND:

- AUX - AUXILIARY RELAY (FOR LOOP PUMP, ETC)
- BC - BLOWER MOTOR CAPACITOR
- BM - BLOWER MOTOR
- BR - BLOWER RELAY
- COMP - COMPRESSOR
- CC - COMPRESSOR CONTACTOR
- CS - CONDENSATE SENSOR (IN DRAIN PAN)
- FS - FREEZE SENSOR
- HPS - HIGH PRESSURE SWITCH
- LED - UNIT STATUS LED DISPLAY
- LP - LOOP PUMP
- LPS - LOW PRESSURE SWITCH
- RV - REVERSING VALVE (HEAT PUMPS)

OPTIONAL COMPONENTS LEGEND:

- [] CBR - 24V CIRCUIT BREAKER
- [] DS - DISCONNECT SWITCH
- [] HSL - HIGH TEMP SUCTION LIMIT (WITH HOT GAS BYPASS ONLY)
- [] LWV - LEAVING WATER VALVE
- [] TB2 - MAIN TERMINAL BLOCK (480V UNITS ONLY)
- [] TB3 - TERMINAL BLOCK DISCONNECT SWITCH (480V UNITS ONLY)
- [] YES - VALVE END SWITCH

NOTES:

1. SEE UNIT NAMEPLATE FOR ELECTRICAL RATING.
2. ALL FIELD WIRING MUST BE IN ACCORDANCE WITH NEC-NFPA #70, COPPER CONDUCTORS ONLY.
3. COMPLETE C BOARD INCLUDES BUILT IN: 270-300 SECOND RANDOM START
300 SECOND DELAY ON BREAK
120 SECOND LOW PRESSURE BYPASS
4. "TEST" DIP SWITCH REDUCES DELAYS TO 10 SEC WHEN SET TO YES. MUST BE SET TO "NO" FOR NORMAL OPERATION.
5. "FREEZE SENSOR" ON CONDENSER WILL OPERATE AT -3.3 C BY DEFAULT. IF -9.4 C OPERATION IS REQUIRED JUMPER R30 MUST BE CUT. IF FREEZE SENSOR IS NOT INSTALLED A JUMPER SHALL BE INSTALLED BETWEEN THE FREEZE1 OR FREEZE2 SENSOR TERMINALS.
6. "ALARM OUTPUT" DIP SWITCH MUST BE SET TO "PULSE" IF BLINKING T-STAT SERVICE LIGHT IS DESIRED.
7. DEFAULT SETTINGS FOR COMPLETE C BOARD FROM FACTORY SHOWN.
8. ALARM OUTPUT IS NORMALLY OPEN (NO) DRY CONTACT. IF 24 VAC IS NEEDED, CONNECT R TO ALR-COM TERMINAL. 24 VAC WILL BE SENSED ON THE ALR-OUT WHEN THE UNIT IS IN ALARM CONDITION. OUTPUT WILL BE PULSED IF PULSE IS SELECTED.
9. TERMINAL BLOCK TB3 LOCATED INSIDE DISCONNECT SWITCH BOX.
10. CHECK FOR PROPER PHASE ROTATION ON UNITS WITH SCROLL COMPRESSORS. REVERSE ROTATION WILL DAMAGE THE COMPRESSOR AND VOID UNIT WARRANTY.
11. FACTORY-MOUNTED LOOP PUMP OR TWO-WAY WATER VALVE. BOTH DEVICES WILL NOT BE PRESENT IN THE SAME UNIT.
12. PUMP MOTOR IS WIRED BETWEEN LINE AND NEUTRAL FOR 380-480VAC UNITS. FOR 208/230VAC UNITS PUMP MOTOR IS WIRED BETWEEN LINES.

Fig. 16 — PSC Motor, Three Phase, Sizes 024 to 048, 070

STATUS LED - BLINK CODES	
1	HIGH PRESSURE FAULT
2	LOW PRESSURE FAULT
3	CONDENSER FREEZE CONDITION
4	CONDENSATE OVERFLOW FAULT
5	BROWNOUT FAULT
6	EVAPORATOR FREEZE CONDITION

FACTORY WIRE _____
FIELD WIRE -----

STANDARD COMPONENTS LEGEND:

- BM - BLOWER MOTOR
- CAP - COMPRESSOR CAPACITOR
- CC - COMPRESSOR CONTACTOR
- CS - CONDENSATE SENSOR (IN DRAIN PAN)
- EMI - EMI FILTER
- FS - FREEZE SENSOR
- HPS - HIGH PRESSURE SWITCH
- L1 - INDUCTOR
- LPS - LOW PRESSURE SWITCH
- PFC - PFC FILTER
- RV - REVERSING VALVE (HEAT PUMPS)

OPTIONAL COMPONENTS LEGEND:

- [] AUX - AUXILIARY RELAY (FOR LOP PUMP, ETC)
- [] CBR - 24V CIRCUIT BREAKER
- [] DS - DISCONNECT SWITCH
- [] EMS - EMERGENCY SHUTDOWN RELAY
- [] HSL - HIGH TEMP SUCTION LIMIT (WITH HOT GAS BYPASS ONLY)
- [] LWV - LOOP WATER VALVE
- [] YES - VALVE END SWITCH

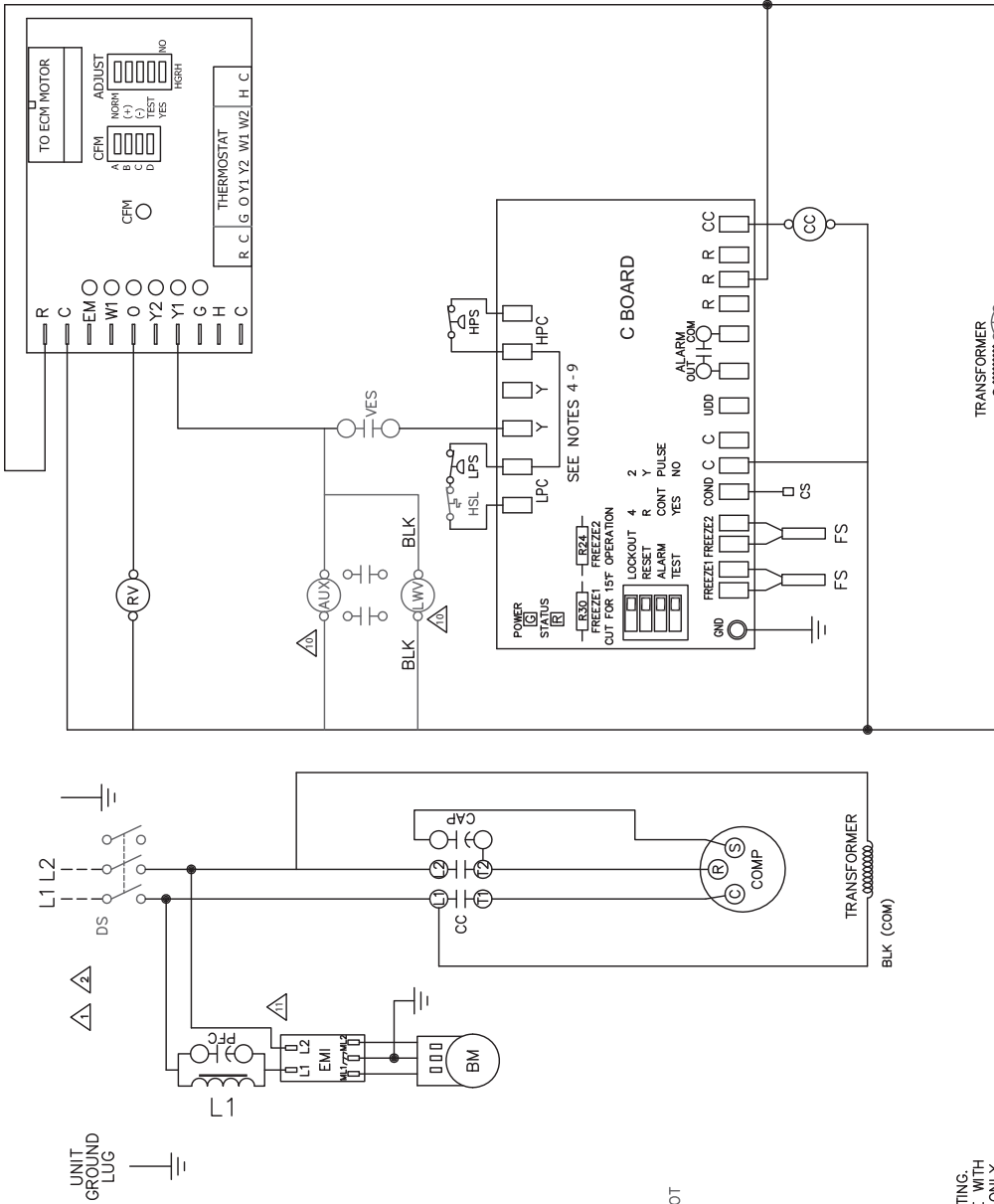

NOTES:

1. SEE UNIT NAME PLATE FOR ELECTRICAL RATING.
2. ALL FIELD WIRING MUST BE IN ACCORDANCE WITH N.E.C.—N.F.P.A. #70, COPPER CONDUCTORS ONLY.
3. FOR ALTERNATE EMS COIL VOLTAGES CONSULT FACTORY.
4. COMPLETE C BOARD INCLUDES BUILT IN: 270–300 SECOND RANDOM START 300 SECOND DELAY ON BREAK 120 SECOND LOW PRESSURE BYPASS
5. "TEST" DIP SWITCH REDUCES DELAYS TO 10 SEC. WHEN SET TO YES. MUST BE SET TO "NO" FOR NORMAL OPERATION.
6. "FREEZE SENSOR" WILL OPERATE AT -1.1 C BY DEFAULT. IF -0.4 C OPERATION IS REQUIRED, JUMPER B30 MUST BE CUT IF FREEZE SENSOR IS NOT INSTALLED A JUMPER SHALL BE INSTALLED BETWEEN THE FREEZE SENSOR TERMINALS.
7. "ALARM" OUTPUT DIP SWITCH MUST BE SET TO "PULSE" IF BLINKING T-STAT SERVICE LIGHT IS DESIRED.
8. DEFAULT SETTINGS FOR UPM BOARD FROM FACTORY SHOWN. ALSO SEE INSTALLATION MANUAL.
9. ALARM OUTPUT IS NORMALLY OPEN (NO) DRY CONTACT. IF 24 VAC IS NEEDED, CONNECT R TO ALR-COM TERMINAL, 24VAC WILL BE SENSED ON THE ALR-OUT WHEN THE UNIT IS IN ALARM CONDITION. OUTPUT WILL BE PULSED IF PULSE IS SELECTED.
10. FACTORY MOUNTED LOOP PUMP OR TWO WAY WATER VALVE. BOTH DEVICES WILL NOT BE PRESENT IN THE SAME UNIT.
11. 220 / 240 50 HZ UNITS ARE FACTORY WIRED FOR 240V OPERATION.

Fig. 17 — ECM Motor, Single Phase, Sizes 015 to 036

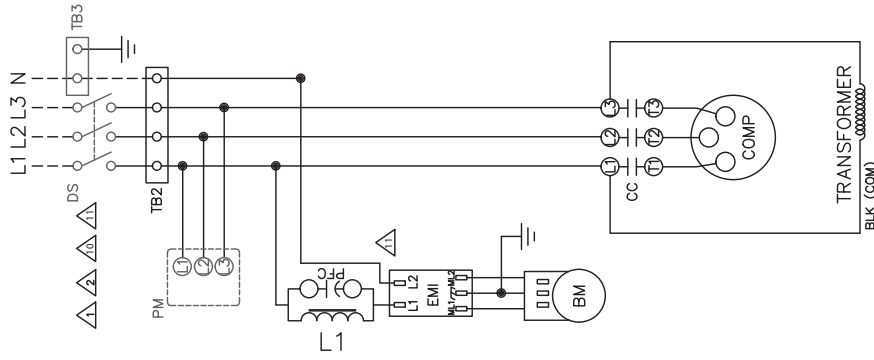
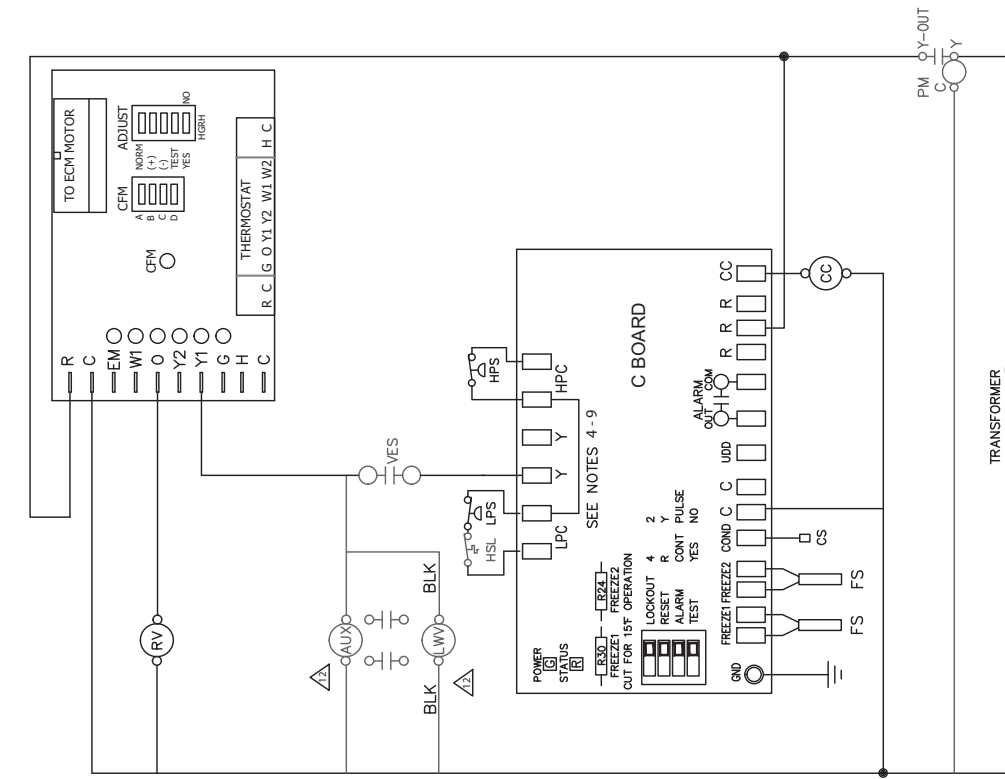

STATUS LED - BLINK CODES	
1	HIGH PRESSURE FAULT
2	LOW PRESSURE FAULT
3	CONDENSER FREEZE CONDITION
4	CONDENSATE OVERFLOW FAULT
5	BROWNOUT FAULT
6	EVAPORATOR FREEZE CONDITION

- FACTORY WIRE —————
- FIELD WIRE - - - - -
- STANDARD COMPONENTS LEGEND:
- BM — BLOWER MOTOR
 - CC — COMPRESSOR CONTACTOR
 - CS — CONDENSATE SENSOR (IN DRAIN PAN)
 - EMI — EMI FILTER
 - EMS — EMERGENCY SHUTDOWN RELAY
 - FS — FREEZE SENSOR SWITCH
 - HPS — HIGH PRESSURE SWITCH
 - L1 — INDUCTOR
 - LPS — LOW PRESSURE SWITCH
 - PFC — PFC FILTER
 - RV — REVERSING VALVE (HEAT PUMPS)
 - TB2 — TERMINAL BLOCK 380-460V UNITS

- OPTIONAL COMPONENTS LEGEND:
- [] AUX — AUXILIARY RELAY (FOR LOP PUMP, ETC)
 - [] CBR — 24V CIRCUIT BREAKER
 - [] DS — DISCONNECT SWITCH
 - [] HSL — HIGH TEMP SUCTION LIMIT (WITH HOT GAS BYPASS ONLY)
 - [] LWV — LOOP WATER VALVE
 - [] PM — PHASE MONITOR
 - [] TB3 — MAIN TERMINAL BLOCK
 - [] YES — VALVE END SWITCH

- NOTES:
- SEE UNIT NAME PLATE FOR ELECTRICAL RATING.
 - ALL FIELD WIRING MUST BE IN ACCORDANCE WITH N.E.C.—N.F.P.A. #70, COPPER CONDUCTORS ONLY.
 - FOR ALTERNATE EMS COIL VOLTAGES CONSULT FACTORY.
 - COMPLETE C BOARD INCLUDES BUILT IN: 270-300 SECOND RANDOM START 120 SECOND LOW PRESSURE BYPASS 300 SECOND DELAY ON BREAK
 - "TEST" DIP SWITCH REDUCES DELAYS TO 10 SEC WHEN SET TO "NO" FOR NORMAL OPERATION.
 - "FREEZE SENSOR" ON CONDENSER WILL OPERATE AT -1.1°C BY DEFAULT. IF -9.4°C OPERATION IS REQUIRED JUMPER R30 MUST BE CUT IF FREEZE SENSOR IS NOT INSTALLED A JUMPER SHALL BE INSTALLED BETWEEN THE FREEZE1 OR FREEZE2 SENSOR TERMINALS.
 - "ALARM" OUTPUT" DIP SWITCH MUST BE SET TO "PULSE" IF BLINKING T-STAT SERVICE LIGHT IS DESIRED.
 - DEFAULT SETTINGS FOR UPM BOARD FROM FACTORY SHOWN. ALSO SEE INSTALLATION MANUAL.
 - ALARM OUTPUT IS NORMALLY OPEN (NO) DRY CONTACT. IF 24 VAC IS NEEDED, CONNECT R TO ALR-COM TERMINAL. 24VAC WILL BE SENSED ON THE ALR-OUT WHEN THE UNIT IS IN ALARM CONDITION. OUTPUT WILL BE PULSED IF PULSE IS SELECTED.
 - TERMINAL BLOCK TB3 LOCATED IN SIDE DISCONNECT SWITCH BOX
 - CHECK FOR PROPER PHASE ROTATION ON UNITS WITH SCROLL COMPRESSORS. REVERSE ROTATION WILL DAMAGE THE COMPRESSOR AND VOID THE WARRANTY.
 - FACTORY MOUNTED LOOP PUMP OR TWO WAY WATER VALVE. BOTH DEVICES WILL NOT BE PRESENT IN THE SAME UNIT. PUMP MOTOR IS WIRED BETWEEN LINE AND NEUTRAL FOR 380-460V UNITS. FOR 208/230VAC UNITS PUMP MOTOR IS WIRED BETWEEN LINES.
 - ECM MOTOR IS WIRED BETWEEN LINE AND NEUTRAL FOR 380-460VAC UNITS. FOR 208/230VAC UNITS ECM MOTOR IS WIRED BETWEEN LINES.

Fig. 18 — ECM Motor, Three Phase, Sizes 030 to 070

Table 9 — 50PCH,PCV (015-070) Unit with ECM Motor Electrical Data

UNIT SIZE	RATED VOLTAGE V-Ph/Hz	VOLTAGE MIN/MAX	COMPRESSOR			FAN MOTOR FLA	FAN MOTOR HP	TOTAL UNIT FLA	MIN CIRCUIT AMP	MAX FUSE/HACR
			QTY	RLA	LRA					
015	220-240/1/50	198/264	1	5.48	24.5	2.80	0.333	8.28	9.7	15
018	220-240/1/50	198/264	1	6.20	48.0	2.80	0.333	9.00	10.6	15
024	380-420/3/50	342/462	1	3.00	30.0	2.80	0.333	5.80	6.6	15
030	220-240/1/50	198/264	1	9.40	48.0	2.80	0.333	12.20	14.6	20
	380-420/3/50	342/462	1	3.60	30.0	2.80	0.333	6.40	7.3	15
036	220-240/1/50	198/264	1	11.40	64.0	4.30	0.5	15.70	18.6	25
	380-420/3/50	342/462	1	4.00	35.0	4.30	0.5	8.30	9.3	15
042	380-420/3/50	342/462	1	4.50	35.0	4.30	0.5	8.80	9.9	15
048	380-420/3/50	342/462	1	5.40	43.0	6.80	0.75	12.20	13.6	15
060	380-420/3/50	342/462	1	7.80	51.5	6.80	0.75	14.60	16.6	20
070	380-420/3/50	342/462	1	8.50	67.1	6.80	0.75	15.30	17.4	25

LEGEND

- FLA — Full Load Amps
- HACR — Heating, Air-Conditioning and Refrigeration
- LRA — Locked Rotor Amps
- RLA — Rated Load Amps

Table 10 — 50PCH,PCV (015-070) Unit with PSC Motor Electrical Data

UNIT SIZE	RATED VOLTAGE	VOLTAGE MIN/MAX	COMPRESSOR			FAN MOTOR FLA	FAN MOTOR HP	TOTAL UNIT FLA	MIN CIRCUIT AMP	MAX FUSE/HACR
			QTY	RLA	LRA					
009	220/240	198/264	1	2.77	18.8	0.85	0.10	3.62	4.3	15
012	220/240	198/253	1	4.35	21.0	0.85	0.10	5.20	6.3	15
015	220/240	198/253	1	5.48	24.5	0.90	0.17	6.40	7.8	15
018	220/240	198/264	1	6.20	48.0	1.60	0.25	7.80	9.4	20
024	380/420	342/462	1	3.00	30.0	0.90	0.25	3.9	4.7	15
030	220/240	198/264	1	9.40	48.0	1.60	0.25	11.0	13.4	25
	380/420	342/462	1	3.60	30.0	0.90	0.25	4.5	5.4	15
036	380/420	342/462	1	4.00	35.0	1.80	0.50	5.8	6.8	15
	220/240	198/264	1	11.20	64.0	3.30	0.50	14.5	17.3	30
042	380/420	342/462	1	4.50	35.0	3.30	0.50	7.8	8.9	15
048	380/420	342/462	1	5.40	43.0	2.80	0.75	8.2	9.6	15
060	380/420	342/462	1	7.80	51.5	2.80	0.75	10.6	12.6	25
070	380/420	342/462	1	8.50	67.1	2.80	0.75	11.3	13.4	25

LEGEND

- FLA — Full Load Amps
- HACR — Heating, Air-Conditioning and Refrigeration
- LRA — Locked Rotor Amps
- RLA — Rated Load Amps

Step 9 — Wire Field Controls

⚠ WARNING

To avoid possible injury or death due to electrical shock, open the power supply disconnect switch and secure it in an open position during installation.

SAFETY DEVICES AND COMPLETE C CONTROL — Each unit is factory provided with a Complete C board controller that controls the compressor operation and monitors the safety. See Fig. 19 and 20.

General — The 50PC Series heat pumps are designed to be controlled by a standard 1 heat / 1 cool heat pump thermostat. The heat pump control circuit operates on 24 VAC control voltage regardless of the unit supply voltage.

Fan operation is controlled by the “G” terminal on the heat pump thermostat terminal block. When “G” is energized the unit fan motor will start operating.

Compressor operation is controlled by the “Y” terminal on the heat pump thermostat terminal block. When “Y” is energized, a signal to start the compressor is sent to the Complete C board. The Complete C board checks a number of safety features before then starting the compressor. If any of the safety features connected to the Complete C board is in a fault condition, the Complete C board will not start the compressor and will flash a fault code on the red status LED indicating the nature of the fault.

Additionally the Complete C board will delay compressor operation randomly on initial start-up (random start delay) and will prevent the compressor from restarting with less than 5 minutes of off time (anti short cycle delay). Once all faults are cleared and the time delays are satisfied, the Complete C board will energize the compressor. The compressor will operate as long as the thermostat calls for “Y” and there are no faults. Refer to the troubleshooting chart for fault diagnostics.

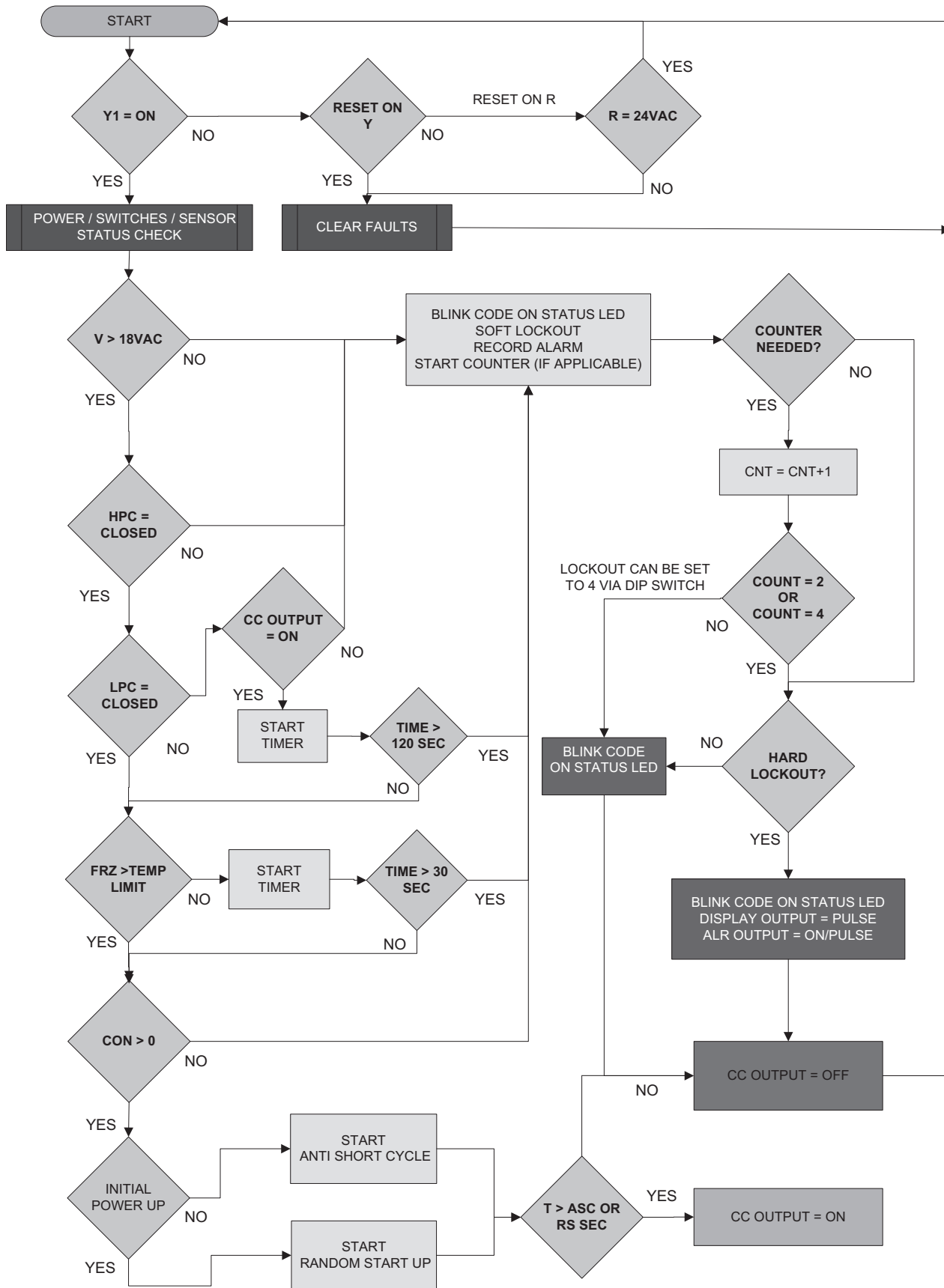
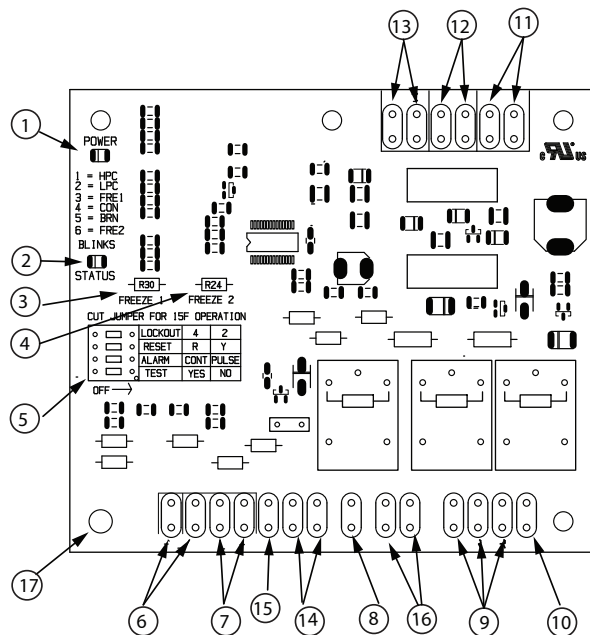

Fig. 19 — Sequence of Operation



1	Board Power Indicator
2	C Board Status LED Indicator
3	Water Coil Freeze Protection Temperature Selection [R30]
4	Air Coil Freeze Protection Temperature Selection
5	C Board Settings
6	Water Coil Freeze Connection
7	Air Coil Freeze Connection
8	LED Status-Diagnostic Connection
9	24VAC Power Input
10	Compressor Contact Output
11	High Pressure Switch Connection
12	Call for Compressor Y1
13	Low Pressure Switch Connection
14	24VAC Power Common
15	Condensate Overflow Sensor
16	Dry Contact
17	C Board Ground Standoff

Fig. 20 — Complete C Control Board

Cooling and Heating Modes — The 50PC Series heat pumps operate in cooling with the reversing valve energized. When the “O” terminal is energized, the heat pump will be in the cooling mode; however, it will not be actively cooling until the “Y” and “G” terminals are also energized. If the “Y” and “G” terminals are energized without the “O” terminal, then the heat pump will operate in the heating mode.

IMPORTANT: If the thermostat is provided with a malfunction light powered off of the common (C) side of the transformer, a jumper between R and COM terminal of ALR contacts must be made.

IMPORTANT: If the thermostat is provided with a malfunction light powered off of the hot (R) side of the transformer, then the thermostat malfunction light connection should be connected directly to the (ALR) contact on the unit’s Complete C board.

If the unit is being connected to a thermostat with a malfunction light, this connection is made at the unit malfunction output or relay. See Table 11 for Complete C board fault blink codes.

Table 11 — Complete C Board Fault Blink Codes

LED BLINKS	FAULT	FAULT CRITERIA
0	None	All fault conditions nominal
1	High Pressure	Refrigerant discharge pressure has exceeded 4137 kPa
2	Low Pressure	Refrigerant suction pressure has fallen below 276 kPa
3	Water Coil Freeze Condition	Refrigerant temperature to the water coil has fallen below -1.1°C for 30 seconds
4	Condensate Overflow	Condensate levels in the unit drain pan are too high
5	Air Coil Freeze Condition	Refrigerant temperature to the air coil has fallen below -1.1°C for 30 seconds
6	Brown Out	Control voltage has fallen below 18 VAC

Safety controls include the following:

- High-pressure switch located in the refrigerant discharge line and wired across the HPC terminals on the Complete C board.
- Low-pressure switch located in the unit refrigerant suction line and wired across terminals LPC1 and LPC2 on the Complete C board.
- Complete C board dry contacts are normally open (NO).
- Water-side freeze protection sensor, mounted close to condensing water coil, monitors refrigerant temperature between condensing water coil and thermal expansion valve. If temperature drops below or remains at freeze limit trip for 30 seconds, the controller will shut down the compressor and enter a soft lockout condition. The default freeze limit trip is -3.3°C ; however, this can be changed to -9.4°C by cutting the R30 or Freeze1 resistor located on top of DIP switch SW1. Refer to Fig. 20, Item 3 for resistor location. If unit is employing a fresh water system (no anti-freeze protection), it is extremely important to have the Freeze1 R30 resistor set to -3.3°C in order to shut down the unit at the appropriate leaving water temperature and protect heat pump from freezing if a freeze sensor is included.
- Evaporator freeze protection sensor, mounted between the thermal expansion device and the evaporator, monitors refrigerant temperature between the evaporator coil and thermal expansion valve. If temperature drops below or remains at freeze limit trip for 30 seconds, the controller will shut down the compressor and enter into a soft lockout condition. The default freeze limit trip is -3.3°C . (See Fig. 21 and 22.)
- The condensate overflow protection sensor is located in the drain pan of the unit and connected to the ‘COND’ terminal on the Complete C board.

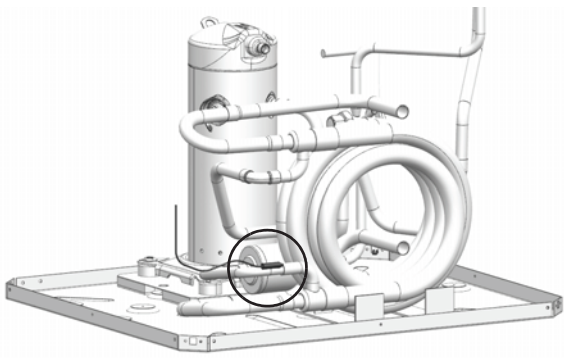

Fig. 21 — Water-Side Freeze Protection Sensor

⚠ CAUTION

If unit is employing a fresh water system (no anti-freeze protection), it is extremely important to have the Freeze1 R30 resistor set to -3.3°C in order to shut down the unit at the appropriate leaving-water temperature and protect the heat pump from freezing if a freeze sensor is included.

IMPORTANT: If 24 VAC output is needed R must be wired to ALR-COM terminal; 24 VAC will be available to the ALR-OUT terminal when the unit is in the alarm condition.

Test DIP Switch — A test DIP switch is provided to reduce all time delays settings to 10 seconds during troubleshooting or verification of unit operation.

⚠ CAUTION

Operation of unit in test mode can lead to accelerated wear and premature failure of components. The "TEST" switch must be set back to "NO" after troubleshooting and/or servicing.

Freeze Sensor — The default setting for the freeze limit trip is -3.3°C (sensor number 1); however, this can be changed to -9.4°C by cutting the R30 resistor located on top of the DIP switch SW1. Since freeze sensor 2 is dedicated to monitor the evaporator coil it is recommended to leave the factory default setting on the board. The Complete C controller will constantly monitor the refrigerant temperature with the sensor mounted close to the condensing water coil between the thermal expansion valve and water coil. If temperature drops below or remains at the freeze limit trip for 30 seconds, the controller will shut the compressor down and enter into a soft lockout condition. Both the status LED and the Alarm contact will be active. The LED will flash three times the code associated with this alarm condition. If this alarm occurs twice (or 4 times if DIP switch is set to 4) within an hour the Complete C controller will enter a hard lockout condition.

IMPORTANT: It is recommended to have a flow switch to prevent the unit from running if water flow is lost.

Intelligent Reset — If a fault condition is initiated, the 5-minute delay on break time period is initiated and the unit will restart after these delays expire. During this period the fault LED will indicate the cause of the fault. If the fault condition still exists or occurs 2 or 4 times (depending on 2 or 4 setting for lockout DIP switch) within 60 minutes, the unit will go into a hard lockout and will require a manual lockout reset. A single condensate overflow fault will cause the unit to go into a hard lockout immediately, and will require a manual lockout reset.

Lockout Reset — A hard lockout can be reset by turning the unit thermostat off and then back on when the RESET DIP switch is set to "Y" or by shutting off unit power at the circuit breaker when the RESET DIP switch is set to "R."

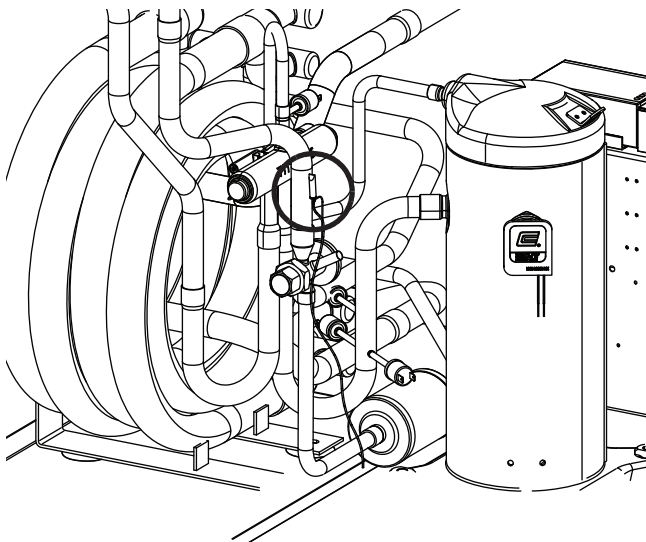

Fig. 22 — Freeze Protection Sensor

The Complete C board includes the following features:

Anti-short Cycle Timer — A 5-minute delay on break timer prevents compressor short cycling.

Random Start — Each controller has a unique random start delay ranging from 270 to 300 seconds on initial power up to reduce the chance of multiple units simultaneously starting at the same time after power up or after a power interruption, thus avoiding creating a large electrical spike.

Low Pressure Bypass Timer — If the compressor is running and the low-pressure switch opens, the controller will keep the compressor ON for 120 seconds. After 2 minutes if the low-pressure switch remains open, the controllers will shut down the compressor and enter a soft lockout. The compressor will not be energized until the low-pressure switch closes and the anti-short cycle time delay expires. If the low-pressure switch opens 2 to 4 times in 1 hour, the unit will enter a hard lockout. In order to exit hard lockout, power to the unit would need to be reset.

PRE-START-UP

System Checkout — After completing the installation, and before energizing the unit, the following system checks should be made prior to initial start-up:

1. Verify that the supply voltage to the heat pump is in accordance with the nameplate ratings.
2. Make sure that all electrical connections are tight and secure.
3. Check the electrical fusing and wiring for the correct size.
4. Verify that the low voltage wiring between the thermostat and the unit is correct.
5. Verify that the water piping is complete and correct.
6. Check that the water flow is correct, and adjust if necessary.
7. Check the blower for free rotation, and that it is secured to the shaft.
8. Verify that vibration isolation has been provided.
9. Verify that unit is serviceable. Be certain that all access panels are secured in place.
10. Verify that the blower support has been removed.
11. Verify that ductwork has been properly fastened to supply and return duct collars.
12. Make sure return air filters are positioned correctly in the filter rack if removed during installation.

AIR COIL — To obtain maximum performance, clean the air coil before starting the unit. A ten percent solution of

dishwasher detergent and water is recommended for both sides of the coil. Rinse thoroughly with water.

Fan Motor Speeds/Changing Speeds

PSC — The standard motor for all 50PC Series heat pumps is a three-speed PSC motor. See Table 12. If a speed change is required, follow the instructions below:

1. Disconnect power to the heat pump.
2. For units with leaded motors, remove the front access cover.
3. Remove the fan speed wire from the fan relay. Clip the 6.4 mm quick connect from the lead and cap the unused lead.
4. Uncap the desired fan speed wire and terminate with a 6.4 mm quick connect. Connect to the fan relay.
5. If the motor is a 380 V motor and the speed is changed from high to medium or low, connect the high speed motor lead to the orange intermediate winding lead instead of simply capping it.

ECM — The optional motor for all size 015 and larger units is an ECM constant airflow motor. See Table 13. If a speed change is required, follow the instructions below:

1. Disconnect power to heat pump.
2. Remove the front access cover.
3. Change the “ADJUST” DIP switch on the ECM motor interface board at the bottom of the unit electrical box from “NORM” to “+” to increase fan speed and from “NORM” to “-” to decrease speed.

Table 12 — 50PCH,PCV009-070 Blower Performance — Standard PSC Unit

UNIT SIZE	FAN SPEED	RATED AIRFLOW (L/s)	EXTERNAL STATIC PRESSURE (Pa)											
			25	50	75	100	125	150	175	200	225	250	275	300
009	Low	141	118	114	113	110	—	—	—	—	—	—	—	—
	Med		149	149	142	130	114	—	—	—	—	—	—	—
	High		165	157	149	142	134	126	—	—	—	—	—	—
012	Low	144	118	114	113	110	—	—	—	—	—	—	—	—
	Med		149	149	142	130	114	—	—	—	—	—	—	—
	High		165	157	149	142	134	126	—	—	—	—	—	—
015	Low	197	197	177	157	—	—	—	—	—	—	—	—	—
	Med		220	205	189	169	157	—	—	—	—	—	—	—
	High		—	230	220	216	197	177	157	—	—	—	—	—
018	Low	280	248	232	220	—	—	—	—	—	—	—	—	—
	Med		319	311	299	287	267	232	—	—	—	—	—	—
	High		—	380	362	342	315	267	208	—	—	—	—	—
024	Low	334	256	240	224	212	201	—	—	—	—	—	—	—
	Med		326	322	315	303	283	244	—	—	—	—	—	—
	High		413	393	374	358	330	279	224	—	—	—	—	—
030	Low	374	291	287	275	260	240	—	—	—	—	—	—	—
	Med		326	319	303	287	267	244	—	—	—	—	—	—
	High		393	374	354	326	295	271	248	—	—	—	—	—
036	Low	472	507	492	472	452	425	393	—	—	—	—	—	—
	Med		555	531	507	480	452	417	354	—	—	—	—	—
	High		570	566	539	507	476	441	393	354	—	—	—	—
042	Low	551	476	476	468	456	441	425	—	—	—	—	—	—
	Med		574	570	562	547	523	492	456	—	—	—	—	—
	High		680	673	657	637	614	574	523	476	425	—	—	—
048	Low	629	570	566	559	551	535	519	—	—	—	—	—	—
	Med		669	657	641	621	602	578	551	—	—	—	—	—
	High		759	736	712	684	657	629	598	562	527	—	—	—
060	Low	787	614	610	606	602	592	580	566	551	—	—	—	—
	Med		743	739	736	732	718	704	680	657	625	590	—	—
	High		873	865	846	826	806	787	763	736	708	669	625	—
070	Low	826	618	614	610	606	602	592	580	566	551	—	—	—
	Med		747	743	739	736	732	718	704	680	657	625	590	—
	High		881	873	865	846	826	806	787	763	736	708	669	625

Table 13 — 50PCH,PCV015-070 Blower Performance — ECM Unit

UNIT SIZE	FAN SPEED	RATED AIRFLOW (L/s)	EXTERNAL STATIC PRESSURE (Pa)											
			25	50	75	100	125	150	175	200	225	250	275	300
015	Low	141	170	170	170	170	170	170	170	170	170	170	—	—
	Med		200	200	200	200	200	200	200	200	200	200	—	—
	High		230	230	230	230	230	230	230	230	230	230	—	—
018	Low	144	201	201	201	201	201	201	201	201	201	201	—	—
	Med		236	236	236	236	236	236	236	236	236	236	—	—
	High		271	271	271	271	271	271	271	271	271	271	—	—
024	Low	197	281	281	281	281	281	281	281	281	281	281	—	—
	Med		330	330	330	330	330	330	330	330	330	330	—	—
	High		380	380	380	380	380	380	380	380	380	380	—	—
030	Low	280	341	341	341	341	341	341	341	341	341	341	—	—
	Med		401	401	401	401	401	401	401	401	401	401	—	—
	High		461	461	461	461	461	461	461	461	461	461	—	—
036	Low	334	401	401	401	401	401	401	401	401	401	401	—	—
	Med		472	472	472	472	472	472	472	472	472	472	—	—
	High		543	543	543	543	543	543	543	543	543	543	—	—
042	Low	374	481	481	481	481	481	481	481	481	481	481	481	—
	Med		566	566	566	566	566	566	566	566	566	566	566	—
	High		651	651	651	651	651	651	651	651	651	651	651	—
048	Low	472	562	562	562	562	562	562	562	562	562	562	562	—
	Med		661	661	661	661	661	661	661	661	661	661	661	—
	High		760	760	760	760	760	760	760	760	760	760	760	—
060	Low	551	682	682	682	682	682	682	682	682	682	682	682	682
	Med		802	802	802	802	802	802	802	802	802	802	802	802
	High		880	880	880	880	880	880	880	880	880	880	880	880
070	Low	629	763	763	763	763	763	763	763	763	763	763	763	763
	Med		897	897	897	897	897	897	897	897	897	897	897	897
	High		1032	1032	1032	1032	1032	1032	1032	1032	1032	1032	1032	1032

START-UP

Use the procedure outlined below to initiate proper unit start-up.

NOTE: This equipment is designed for indoor installation only.

Operating Limits

ENVIRONMENT — This equipment is designed for indoor installation only. Extreme variations in temperature, humidity and corrosive water or air will adversely affect the unit performance, reliability and service life.

POWER SUPPLY — A voltage variation of ± 10% of nameplate utilization voltage is acceptable.

UNIT STARTING CONDITIONS — Depending on the model, units start and operate in an ambient temperature of 7.2°C with entering-air temperature at 4.4°C or 10.0°C, entering-water temperature at -6.7°C or 10.0°C and with both air and water at the flow rates used.

NOTE: These operating limits are not normal or continuous operating conditions. Assume that such a start-up is for the purpose of bringing the building space up to occupancy temperature. See Table 14 for operating limits.

⚠ WARNING
When the disconnect switch is closed, high voltage is present in some areas of the electrical panel. Exercise caution when working with the energized equipment. Failure to heed this warning could lead to personal injury.

1. Restore power to system.
2. Turn thermostat fan position to ON. Blower should start.
3. Balance airflow at registers.
4. Adjust all valves to the full open position and turn on the line power to all heat pump units.
5. Operate unit in the cooling cycle first, then the heating cycle. Refer to Table 14 for unit operating limits. Allow 15 minutes between cooling and heating tests for

pressure to equalize. See Table 15 for water temperature changes through the heat exchanger.

NOTE: Two factors determine the operating limits of a unit: entering-air temperature and water temperature. Whenever any of these factors are at a minimum or maximum level, the other two factors must be at a normal level to ensure proper unit operation.

Table 14 — Operating Limits

AIR LIMITS	EXTENDED RANGE OPTION
COOLING	
Minimum ambient air temperature C	10.0
Maximum ambient air temperature C	37.8
Minimum evaporator entering air db/wb C	20/13.9
Rated air coil entering air db/wb C	26.7/19.5
Maximum evaporator entering air db/wb C	35.0/29.5
Minimum water coil entering fluid temperature C	10.0
Water loop typical coil entering fluid range temperature C	21.1/32.2
Maximum water coil entering fluid temperature C	37.7
HEATING	
Minimum ambient air temperature C	4.4
Maximum ambient air temperature C	29.5
Minimum evaporator entering air db C	10.0
Rated air coil entering air C	20.0
Maximum evaporator entering air db C	26.7
Normal water coil entering fluid range C	-3.9/26.7*
Minimum water coil entering Fluid C	-6.7*

LEGEND

db — Dry Bulb
wb — Wet Bulb

*Antifreeze solution is required at these fluid temperatures.

Table 15 — Water Temperature Change Through Heat Exchanger

WATER FLOW RATE (GPM)	COOLING RISE (C)		HEATING DROP (C)	
	Min	Max	Min	Max
For Closed Loop: Ground Source or Cooling/Boiler Systems at 0.054 L/(S-kW)	5.0	6.7	2.2	4.4
For Open Loop: Ground Water Systems at 0.027 L/(S-kW)	11.1	14.5	5.6	9.5

Scroll Compressor Rotation — It is important to be certain compressor is rotating in the proper direction. To determine whether or not compressor is rotating in the proper direction:

1. Connect service gages to suction and discharge pressure fittings.
2. Energize the compressor.
3. The suction pressure should drop and the discharge pressure should rise, as is normal on any start-up.

If the suction pressure does not drop and the discharge pressure does not rise to normal levels (see Tables 16-26):

1. Turn off power to the unit. Install disconnect tag.
2. Reverse any two of the unit power leads.
3. Reapply power to the unit and verify pressures are correct.

The suction and discharge pressure levels should now move to their normal start-up levels.

When the compressor is rotating in the wrong direction, the unit makes more noise and does not provide cooling.

After a few minutes of reverse operation, the scroll compressor internal overload protection will open, thus activating the unit lockout. This requires a manual reset. To reset, turn the thermostat on and then off.

NOTE: There is a 5-minute time delay before the compressor will start.

Unit Start-Up

1. Set the thermostat to the highest setting.
2. Set the thermostat system switch to “COOL” and the fan switch to the “AUTO” position. The reversing valve solenoid should energize. The compressor and fan should not run.
3. Reduce the thermostat setting approximately 3° below the room temperature.
4. Verify the heat pump is operating in the cooling mode.
5. Turn the thermostat system switch to the “OFF” position. The unit should stop running and the reversing valve should de energize.
6. Leave the unit off for approximately 5 minutes to allow for system equalization.
7. Turn the thermostat to the lowest setting.
8. Set the thermostat switch to “HEAT”.
9. Increase the thermostat setting approximately 3° above the room temperature.
10. Verify the heat pump is operating in the heating mode.
11. Set the thermostat to maintain the desired space temperature.
12. Check for vibrations, leaks, etc.

Table 16 — 50PC009 Typical Unit Operating Pressures and Temperatures

ENTERING WATER TEMP (C)	WATER FLOW (L/s)	COOLING				HEATING			
		SUCTION PRESSURE (kPa)	DISCHARGE PRESSURE (kPa)	WATER TEMP RISE (C)	AIR TEMP DROP (C)DB	SUCTION PRESSURE (kPa)	DISCHARGE PRESSURE (kPa)	WATER TEMP DROP (C)	AIR TEMP RISE (C)
-3.8	0.11	—	—	—	—	628-766	1731-2117	2.8-3.3	11.7-13.9
	0.15	—	—	—	—	655-800	1766-2159	1.7-2.2	12.2-14.4
6.2	0.11	772-945	993-1214	7.8-9.4	12.2-15.0	738-897	1841-2255	3.3-3.9	13.3-16.1
	0.15	731-897	945-1152	5.6-6.7	12.8-15.6	772-945	1883-2297	2.2-2.8	13.9-16.7
16.2	0.11	800-979	1221-1497	7.2-8.9	11.7-14.4	848-1035	1959-2393	3.9-5.0	15.0-18.3
	0.15	766-931	1166-1421	5.0-6.7	12.2-15.0	890-1090	1993-2435	2.8-3.3	15.6-18.9
26.2	0.11	835-1021	1455-1779	7.2-8.9	11.7-14.4	959-1172	2069-2524	4.4-5.6	16.7-20.6
	0.15	793-966	1379-1690	5.0-6.1	12.2-15.0	1007-1235	2110-2579	3.3-3.9	17.8-21.7
36.2	0.11	869-1062	1690-2062	7.2-8.3	11.1-13.9	1076-1310	2179-2662	5.0-6.7	18.3-22.8
	0.15	821-1007	1600-1959	5.0-6.1	11.7-14.4	1124-1379	2221-2717	3.9-4.4	19.4-23.9
46.2	0.11	897-1097	1917-2345	6.7-8.3	11.1-13.3	1186-1448	2290-2800	6.1-7.2	20.0-24.4
	0.15	855-1041	1821-2228	5.0-6.1	11.7-14.4	1241-1517	2338-2855	4.4-5.0	21.1-26.1
56.2	0.11	931-1138	2152-2628	6.7-8.3	10.6-13.3	1297-1586	2407-2938	6.7-8.3	21.7-26.7
	0.15	883-1083	2042-2497	5.0-5.6	11.1-13.9	1359-1662	2448-2993	4.4-5.6	22.8-28.3
66.2	0.11	966-1179	2379-2911	6.7-7.8	10.6-12.8	—	—	—	—
	0.15	917-1117	2262-2766	4.4-5.6	11.1-13.3	—	—	—	—

LEGEND

- DB — Dry Bulb
 — — No Operation in This Temperature Range

Table 17 — 50PC012 Typical Unit Operating Pressures and Temperatures

ENTERING WATER TEMP (C)	WATER FLOW (L/s)	COOLING				HEATING			
		SUCTION PRESSURE (kPa)	DISCHARGE PRESSURE (kPa)	WATER TEMP RISE (C)	AIR TEMP DROP (C)DB	SUCTION PRESSURE (kPa)	DISCHARGE PRESSURE (kPa)	WATER TEMP DROP (C)	AIR TEMP RISE (C)
-3.8	0.16	—	—	—	—	503-614	1835-2242	2.8-3.3	8.3-10.0
	0.19	—	—	—	—	531-648	1876-2297	1.7-2.2	8.9-10.6
6.2	0.16	807-986	1304-1593	7.8-9.4	10.0-12.2	593-724	1924-2352	3.3-3.9	9.4-11.7
	0.19	772-945	1228-1497	4.4-5.0	10.6-13.3	621-759	1973-2414	2.2-2.8	10.0-12.2
16.2	0.16	869-1062	1524-1862	7.8-9.4	10.0-11.7	1117-1366	2021-2469	3.9-4.4	11.1-13.3
	0.19	835-1021	1428-1745	4.4-5.0	10.6-12.8	1172-1435	2069-2524	2.8-3.3	11.7-13.9
26.2	0.16	904-1104	1738-2124	7.2-8.9	9.4-11.7	759-924	2110-2579	4.4-5.6	12.2-15.0
	0.19	862-1055	1635-2000	4.4-5.0	10.0-12.2	793-972	2166-2642	3.3-3.9	12.8-16.1
36.2	0.16	931-1138	1959-2393	7.2-8.9	9.4-11.1	841-1035	2207-2697	5.0-6.1	13.3-16.7
	0.19	897-1090	1835-2248	3.9-5.0	10.0-12.2	890-1083	2255-2759	3.3-4.4	14.4-17.8
46.2	0.16	966-1179	2207-2697	7.2-8.9	8.9-11.1	924-1131	2297-2807	6.1-7.2	15.0-18.3
	0.19	924-1131	2069-2531	3.9-5.0	9.4-11.7	972-1186	2352-2876	3.9-5.0	15.6-19.4
56.2	0.16	993-1214	2483-3035	7.2-8.9	8.9-10.6	1014-1235	2393-2924	6.7-7.8	16.1-20.0
	0.19	952-1166	2331-2855	3.9-5.0	9.4-11.7	1062-1297	2448-2993	4.4-5.6	17.2-21.1
66.2	0.16	1028-1255	2793-3414	7.2-8.3	8.3-10.6	—	—	—	—
	0.19	986-1200	2628-3207	3.9-5.0	8.9-11.1	—	—	—	—

LEGEND

DB — Dry Bulb
 — — No Operation in This Temperature Range

Table 18 — 50PC015 Typical Unit Operating Pressures and Temperatures

ENTERING WATER TEMP (C)	WATER FLOW (L/s)	COOLING				HEATING			
		SUCTION PRESSURE (kPa)	DISCHARGE PRESSURE (kPa)	WATER TEMP RISE (C)	AIR TEMP DROP (C)DB	SUCTION PRESSURE (kPa)	DISCHARGE PRESSURE (kPa)	WATER TEMP DROP (C)	AIR TEMP RISE (C)
-3.8	0.18	—	—	—	—	510-621	1683-2062	1.7-2.2	7.2-8.3
	0.24	—	—	—	—	538-655	1731-2110	1.1-1.7	7.2-8.9
6.2	0.18	841-1028	1262-1545	7.8-10.0	10.6-12.8	600-731	1773-2166	2.2-2.8	8.3-10.0
	0.24	807-986	1186-1448	4.4-5.6	11.1-13.3	628-766	1814-2221	1.7-2.2	8.9-10.6
16.2	0.18	904-1104	1476-1800	7.8-10.0	10.0-12.2	1131-1386	1855-2269	2.8-3.3	9.4-11.1
	0.24	869-1062	1386-1690	4.4-5.6	10.6-13.3	1193-1455	1904-2324	1.7-2.2	10.0-12.2
26.2	0.18	938-1145	1683-2055	7.8-9.4	10.0-12.2	766-938	1945-2373	3.3-3.9	10.6-12.8
	0.24	904-1104	1586-1938	4.4-5.6	10.6-12.8	807-986	1993-2435	2.2-2.8	11.1-13.3
36.2	0.18	972-1186	1897-2317	7.8-9.4	9.4-11.7	855-1048	2028-2483	3.9-4.4	11.7-13.9
	0.24	931-1138	1779-2179	4.4-5.6	10.0-12.2	904-1104	2083-2545	2.8-3.3	12.2-15.0
46.2	0.18	1000-1228	2138-2607	7.8-9.4	9.4-11.1	938-1145	2117-2586	4.4-5.0	12.8-15.6
	0.24	966-1179	2007-2455	4.4-5.6	10.0-12.2	986-1207	2116-2648	2.8-3.3	13.3-16.7
56.2	0.18	1035-1262	2407-2938	7.8-9.4	8.9-11.1	1028-1255	2200-2690	4.4-5.6	13.9-16.7
	0.24	993-1214	2262-2766	4.4-5.0	9.4-11.7	1076-1317	2255-2759	3.3-3.9	14.4-17.8
66.2	0.18	1069-1304	2704-3311	7.2-8.9	8.9-10.6	—	—	—	—
	0.24	1028-1255	2545-3111	4.4-5.0	9.4-11.7	—	—	—	—

LEGEND

DB — Dry Bulb
 — — No Operation in This Temperature Range

Table 19 — 50PC018 Typical Unit Operating Pressures and Temperatures

ENTERING WATER TEMP (C)	WATER FLOW (L/s)	COOLING				HEATING			
		SUCTION PRESSURE (kPa)	DISCHARGE PRESSURE (kPa)	WATER TEMP RISE (C)	AIR TEMP DROP (C)DB	SUCTION PRESSURE (kPa)	DISCHARGE PRESSURE (kPa)	WATER TEMP DROP (C)	AIR TEMP RISE (C)
-3.8	0.19	—	—	—	—	448-552	1945-2373	3.3-3.9	7.8-9.4
	0.32	—	—	—	—	503-614	2028-2476	1.7-2.2	8.3-10.0
6.2	0.19	835-1021	1269-1552	9.4-11.7	10.0-12.2	552-676	2062-2517	3.9-5.0	8.9-11.1
	0.32	807-986	1152-1407	5.6-7.2	10.6-12.8	614-745	2145-2621	2.2-2.8	9.4-11.7
16.2	0.19	848-1041	1531-1869	9.4-11.1	9.4-11.7	655-800	2173-2655	5.0-6.1	10.6-12.8
	0.32	821-1000	1393-1704	5.6-6.7	10.0-12.8	724-883	2269-2773	2.8-3.9	11.1-13.3
26.2	0.19	862-1055	1793-2193	8.9-10.6	9.4-11.7	752-917	2293-2800	6.1-7.2	11.7-14.4
	0.32	828-1014	1635-1993	5.6-6.7	10.0-12.2	835-1021	2386-2917	3.3-4.4	12.2-15.0
36.2	0.19	876-1069	2055-2517	8.3-10.6	9.4-11.1	855-1041	2407-2945	6.7-2.8	12.8-15.6
	0.32	841-1028	1869-2283	5.0-6.1	10.0-11.7	952-1159	2511-3062	3.9-5.0	13.9-16.7
46.2	0.19	890-1090	2317-2835	7.8-10.0	8.9-11.1	952-1166	2524-3083	7.8-3.9	14.4-17.2
	0.32	855-1048	2110-2579	5.0-6.1	9.4-11.7	1062-1297	2628-3214	4.4-5.6	15.0-18.3
56.2	0.19	904-1104	2579-3159	7.8-9.4	8.9-10.6	1055-1290	2642-3228	8.9-8.9	15.6-18.9
	0.32	869-1062	2345-2869	4.4-5.6	9.4-11.1	1172-1435	2752-3359	5.0-6.7	16.1-20.0
66.2	0.19	917-1117	2848-3476	7.2-8.9	8.3-10.6	—	—	—	—
	0.32	883-1076	2586-3159	4.4-5.6	8.9-11.1	—	—	—	—

LEGEND

DB — Dry Bulb
 — — No Operation in This Temperature Range

Table 20 — 50PC024 Typical Unit Operating Pressures and Temperatures

ENTERING WATER TEMP (C)	WATER FLOW (L/s)	COOLING				HEATING			
		SUCTION PRESSURE (kPa)	DISCHARGE PRESSURE (kPa)	WATER TEMP RISE (C)	AIR TEMP DROP (C)DB	SUCTION PRESSURE (kPa)	DISCHARGE PRESSURE (kPa)	WATER TEMP DROP (C)	AIR TEMP RISE (C)
-3.8	0.32	—	—	—	—	497-600	2042-2490	2.8-3.3	11.7-13.9
	0.44	—	—	—	—	517-635	2076-2538	1.7-2.2	12.2-14.4
6.2	0.32	786-959	1069-1310	7.8-9.4	12.2-15.0	607-738	2166-2648	3.3-3.9	13.3-16.1
	0.44	745-910	1014-1241	5.6-6.7	12.8-15.6	635-772	2214-2704	2.2-2.8	13.9-16.7
16.2	0.32	800-979	1324-1614	7.2-8.9	11.7-14.4	717-876	2297-2807	3.9-5.0	15.0-18.3
	0.44	766-931	1255-1531	5.0-6.7	12.2-15.0	752-917	2345-2862	2.8-3.3	15.6-18.9
26.2	0.32	821-1007	1573-1924	7.2-8.9	11.7-14.4	828-1007	2428-2966	4.4-5.6	16.7-20.6
	0.44	779-952	1497-1828	5.0-6.1	12.2-15.0	862-1055	2476-3028	3.3-3.9	17.8-21.7
36.2	0.32	841-1028	1821-2228	7.2-8.3	11.1-13.9	938-1145	2559-3124	5.0-6.7	18.3-22.8
	0.44	800-979	1731-2117	5.0-6.1	11.7-14.4	979-1200	2607-3186	3.9-4.4	19.4-23.9
46.2	0.32	862-1048	2076-2538	6.7-8.3	11.1-13.3	1048-1276	2683-3283	6.1-7.2	20.0-24.4
	0.44	814-1000	1973-2407	5.0-6.1	11.7-14.4	1097-1338	2738-3345	4.4-5.0	21.1-26.1
56.2	0.32	876-1076	2324-2842	6.7-8.3	10.6-13.3	1159-1414	2814-3442	6.7-8.3	21.7-26.7
	0.44	835-1021	2207-2704	5.0-5.6	11.1-13.9	1214-1283	2869-3511	4.4-5.6	22.8-28.3
66.2	0.32	897-1097	2579-3152	6.7-7.8	10.6-12.8	—	—	—	—
	0.44	855-1041	2448-2993	4.4-5.6	11.1-13.3	—	—	—	—

LEGEND

DB — Dry Bulb
 — — No Operation in This Temperature Range

Table 21 — 50PC030 Typical Unit Operating Pressures and Temperatures

ENTERING WATER TEMP (C)	WATER FLOW (L/s)	COOLING				HEATING			
		SUCTION PRESSURE (kPa)	DISCHARGE PRESSURE (kPa)	WATER TEMP RISE (C)	AIR TEMP DROP (C)DB	SUCTION PRESSURE (kPa)	DISCHARGE PRESSURE (kPa)	WATER TEMP DROP (C)	AIR TEMP RISE (C)
-3.8	0.22	—	—	—	—	503-614	1835-2242	2.8-3.3	8.3-10.0
	0.47	—	—	—	—	531-648	1876-2297	1.7-2.2	8.9-10.6
6.2	0.22	807-986	1304-1593	7.8-9.4	10.0-12.2	596-724	1924-2352	3.3-3.9	9.4-11.7
	0.47	772-945	1228-1497	4.4-5.0	10.6-13.3	621-759	1973-2414	2.2-2.8	10.0-12.2
16.2	0.22	869-1062	1524-1862	7.8-9.4	10.0-11.7	1117-1366	2021-2469	3.9-4.4	11.1-13.3
	0.47	835-1021	1428-1745	4.4-5.0	10.6-12.8	1172-1435	2069-2524	2.8-3.3	11.7-13.9
26.2	0.22	904-1104	1738-2124	7.2-8.9	9.4-11.7	759-924	2110-2579	4.4-5.6	12.2-15.0
	0.47	862-1055	1635-2000	4.4-5.0	10.0-12.2	793-972	2166-2642	3.3-3.9	12.8-16.1
36.2	0.22	931-1138	1959-2393	7.2-8.9	9.4-11.1	841-1035	2207-2697	5.0-6.1	13.3-16.7
	0.47	897-1090	1835-2248	3.9-5.0	10.0-12.2	890-1083	2255-2759	3.3-4.4	14.4-17.8
46.2	0.22	966-1179	2207-2697	7.2-8.9	8.9-11.1	924-1131	2297-2807	6.1-7.2	15.0-18.3
	0.47	924-1131	2069-2531	3.9-5.0	9.4-11.7	972-1186	2352-2876	3.9-5.0	15.6-19.4
56.2	0.22	993-1214	2483-3035	7.2-8.9	8.9-10.6	1014-1235	2393-2924	6.7-7.8	16.1-20.0
	0.47	952-1166	2331-2855	3.9-5.0	9.4-11.7	1062-1297	2448-2993	4.4-5.6	17.2-21.1
66.2	0.22	1028-1255	2793-3414	7.2-8.3	8.3-10.6	—	—	—	—
	0.47	986-1200	2628-3207	3.9-5.0	8.9-11.1	—	—	—	—

LEGEND

DB — Dry Bulb
 — — No Operation in This Temperature Range

Table 22 — 50PC036 Typical Unit Operating Pressures and Temperatures

ENTERING WATER TEMP (C)	WATER FLOW (L/s)	COOLING				HEATING			
		SUCTION PRESSURE (kPa)	DISCHARGE PRESSURE (kPa)	WATER TEMP RISE (C)	AIR TEMP DROP (C)DB	SUCTION PRESSURE (kPa)	DISCHARGE PRESSURE (kPa)	WATER TEMP DROP (C)	AIR TEMP RISE (C)
-3.8	0.28	—	—	—	—	510-621	1683-2062	1.7-2.2	7.2-8.3
	0.57	—	—	—	—	538-655	1731-2110	1.1-1.7	7.2-8.9
6.2	0.28	841-1028	1262-1545	7.8-10.0	10.6-12.8	600-731	1773-2166	2.2-2.8	8.3-10.0
	0.57	807-986	1186-1448	4.4-5.6	11.1-13.3	628-766	1814-2221	1.7-2.2	8.9-10.6
16.2	0.28	904-1104	1476-1800	7.8-10.0	10.0-12.2	1131-1386	1855-2269	2.8-3.3	9.4-11.1
	0.57	869-1062	1386-1690	4.4-5.6	10.6-13.3	1193-1455	1904-2324	1.7-2.2	10.0-12.2
26.2	0.28	938-1145	1683-2055	7.8-9.4	10.0-12.2	766-938	1945-2373	3.3-3.9	10.6-12.8
	0.57	904-1104	1586-1938	4.4-5.6	10.6-12.8	807-986	1993-2435	2.2-2.8	11.1-13.3
36.2	0.28	972-1186	1897-2317	7.8-9.4	9.4-11.7	855-1048	2028-2483	3.9-4.4	11.7-13.9
	0.57	931-1138	1779-2179	4.4-5.6	10.0-12.2	904-1104	2083-2545	2.8-3.3	12.2-15.0
46.2	0.28	1000-1228	2138-2607	7.8-9.4	9.4-11.1	938-1145	2117-2586	4.4-5.0	12.8-15.6
	0.57	966-1179	2007-2455	4.4-5.6	10.0-12.2	986-1207	2166-2648	2.8-3.3	13.3-16.7
56.2	0.28	1035-1262	2407-2938	7.8-9.4	8.9-11.1	1028-1255	2200-2690	4.4-3.9	13.9-16.7
	0.57	993-1214	2262-2766	4.4-5.0	9.4-11.7	1076-1317	2255-2759	3.3-3.9	14.4-17.8
66.2	0.28	1069-1304	2704-3311	7.2-8.9	8.9-10.6	—	—	—	—
	0.57	1028-1255	2545-3111	4.4-5.0	9.4-11.7	—	—	—	—

LEGEND

DB — Dry Bulb
 — — No Operation in This Temperature Range

Table 23 — 50PC042 Typical Unit Operating Pressures and Temperatures

ENTERING WATER TEMP (C)	WATER FLOW (L/s)	COOLING				HEATING			
		SUCTION PRESSURE (kPa)	DISCHARGE PRESSURE (kPa)	WATER TEMP RISE (C)	AIR TEMP DROP (C)DB	SUCTION PRESSURE (kPa)	DISCHARGE PRESSURE (kPa)	WATER TEMP DROP (C)	AIR TEMP RISE (C)
-3.8	0.38	—	—	—	—	441-538	1710-2090	2.8-3.3	8.3-10.0
	0.63	—	—	—	—	462-566	1725-2145	1.7-2.2	8.9-10.6
6.2	0.38	752-924	1262-1545	10.0-12.2	10.6-12.8	517-628	1800-2200	3.3-4.4	9.4-11.7
	0.63	724-883	1186-1448	5.6-6.7	11.1-13.9	545-662	1741-2255	2.2-2.8	10.0-12.8
16.2	0.38	814-993	1476-1800	10.0-12.2	10.6-12.8	979-1193	1883-2304	4.4-5.6	11.1-13.3
	0.63	779-952	1386-1690	5.6-6.7	11.1-13.3	1028-1255	1931-2359	2.8-3.9	11.7-14.4
26.2	0.38	841-1028	1683-2055	9.4-11.7	10.0-12.2	662-807	1973-2407	5.0-6.1	12.2-15.0
	0.63	807-986	1586-1938	5.6-6.7	10.6-13.3	697-848	2021-2469	3.3-4.4	13.3-16.1
36.2	0.38	869-1062	1897-2317	9.4-11.7	10.0-12.2	738-904	2062-2517	6.1-7.2	13.9-16.7
	0.63	835-1021	1779-2179	5.6-6.7	10.6-12.8	779-952	2110-2579	3.9-5.0	14.4-17.8
46.2	0.38	897-1097	2138-2607	9.4-11.7	9.4-11.7	807-986	2145-2621	6.7-8.3	15.0-18.3
	0.63	862-1055	2007-2455	5.6-6.7	10.0-12.2	848-1041	2200-2690	4.4-5.6	16.1-19.4
56.2	0.38	924-1131	2407-2938	9.4-11.1	9.4-11.1	883-1083	2235-2731	7.2-8.9	16.1-20.0
	0.63	890-1090	2262-2766	5.0-6.7	10.0-12.2	931-1138	2290-2800	5.0-6.1	17.2-21.1
66.2	0.38	959-1172	2704-3311	8.9-11.1	8.9-11.1	—	—	—	—
	0.63	917-1124	2545-3111	5.0-6.7	9.4-11.7	—	—	—	—

LEGEND

DB — Dry Bulb
 — — No Operation in This Temperature Range

Table 24 — 50PC048 Typical Unit Operating Pressures and Temperatures

ENTERING WATER TEMP (C)	WATER FLOW (L/s)	COOLING				HEATING			
		SUCTION PRESSURE (kPa)	DISCHARGE PRESSURE (kPa)	WATER TEMP RISE (C)	AIR TEMP DROP (C)DB	SUCTION PRESSURE (kPa)	DISCHARGE PRESSURE (kPa)	WATER TEMP DROP (C)	AIR TEMP RISE (C)
-3.8	0.38	—	—	—	—	490-600	1910-2338	3.3-3.9	8.3-10.6
	0.63	—	—	—	—	517-635	1959-2393	2.2-2.8	8.9-11.1
6.2	0.38	814-993	1338-1635	11.7-13.9	10.6-12.8	579-703	2007-2455	3.9-5.0	10.0-12.2
	0.63	779-952	1255-1538	6.7-7.8	11.1-13.3	607-745	2062-2517	2.8-3.3	10.6-12.8
16.2	0.38	876-1069	1559-1904	11.7-13.9	10.0-12.2	1097-1338	2104-2573	5.0-6.1	11.1-13.9
	0.63	841-1028	1469-1793	6.7-7.8	10.6-13.3	1152-1407	2159-2642	3.3-3.9	11.7-14.4
26.2	0.38	904-1104	1786-2179	11.7-13.9	10.0-12.2	745-910	2207-2697	5.6-7.2	12.8-15.6
	0.63	869-1062	1676-2048	6.7-7.8	10.6-12.8	779-952	2262-2759	3.9-5.0	13.3-16.1
36.2	0.38	938-1145	2007-2448	11.1-13.9	9.4-11.7	828-1014	2304-2814	6.7-8.3	13.9-17.2
	0.63	897-1097	1883-2304	6.7-7.8	10.0-12.2	869-1062	2359-2883	4.4-5.6	15.0-17.8
46.2	0.38	966-1179	2262-2766	11.1-13.3	9.4-11.1	904-1110	2400-2931	7.8-9.4	15.0-18.9
	0.63	931-1138	2124-2600	6.1-7.8	10.0-12.2	952-1166	2455-3007	5.0-6.1	16.1-20.0
56.2	0.38	1000-1221	2545-3111	11.1-13.3	8.9-11.1	993-1214	2497-3048	8.3-10.0	16.7-20.6
	0.63	959-1172	2393-2924	6.1-7.8	9.4-11.7	1041-1276	2559-3124	5.6-6.7	17.8-21.7
66.2	0.38	1028-1262	2862-3504	10.6-13.3	8.9-10.6	—	—	—	—
	0.63	986-1207	2697-3290	6.1-7.8	9.4-11.7	—	—	—	—

LEGEND

DB — Dry Bulb
 — — No Operation in This Temperature Range

Table 25 — 50PC060 Typical Unit Operating Pressures and Temperatures

ENTERING WATER TEMP (C)	WATER FLOW (L/s)	COOLING				HEATING			
		SUCTION PRESSURE (kPa)	DISCHARGE PRESSURE (kPa)	WATER TEMP RISE (C)	AIR TEMP DROP (C)DB	SUCTION PRESSURE (kPa)	DISCHARGE PRESSURE (kPa)	WATER TEMP DROP (C)	AIR TEMP RISE (C)
-3.8	0.51	—	—	—	—	469-579	1766-2159	2.8-3.9	10.6-12.8
	0.76	—	—	—	—	503-614	1800-2200	2.2-2.8	11.1-13.9
6.2	0.51	779-952	1193-1462	10.0-12.2	10.6-12.8	559-683	1910-2338	3.9-4.4	12.2-14.4
	0.76	759-924	1117-1366	6.7-7.8	11.1-13.3	593-724	1952-2386	2.8-3.3	12.8-15.6
16.2	0.51	800-979	1428-1745	9.4-11.7	10.6-12.8	641-786	2062-2517	4.4-5.0	13.3-16.1
	0.76	772-945	1331-1628	6.7-7.8	10.6-13.3	683-835	2104-2573	3.3-3.9	13.9-17.2
26.2	0.51	814-1000	1655-2021	9.4-11.7	10.0-12.8	731-890	2214-2704	5.0-6.1	14.4-17.8
	0.76	793-966	1545-1890	6.1-7.8	10.6-12.8	779-952	2255-2759	3.9-4.4	15.6-18.9
36.2	0.51	835-1021	1883-2304	9.4-11.7	10.0-12.2	814-1000	2359-2883	5.6-6.7	16.1-19.4
	0.76	807-986	1759-2152	6.1-7.8	10.6-12.8	869-1062	2407-2945	4.4-5.0	16.7-20.6
46.2	0.51	848-1041	2117-2586	8.9-11.1	10.0-12.2	904-1104	2511-3062	6.1-7.8	17.2-21.1
	0.76	828-1007	1979-2414	6.1-7.2	10.6-12.8	959-1172	2559-3131	4.4-5.6	18.3-22.2
56.2	0.51	869-1062	2345-2869	8.9-11.1	10.0-12.2	986-1207	2655-3248	6.7-8.3	18.3-22.8
	0.76	841-1028	2193-2676	6.1-7.2	10.0-12.2	1048-1283	2711-3311	5.0-6.1	19.4-23.9
66.2	0.51	883-1083	2573-3145	8.9-10.6	9.4-11.7	—	—	—	—
	0.76	862-1048	2407-2938	6.1-7.2	10.0-12.2	—	—	—	—

LEGEND

DB — Dry Bulb
 — — No Operation in This Temperature Range

Table 26 — 50PC070 Typical Unit Operating Pressures and Temperatures

ENTERING WATER TEMP (C)	WATER FLOW (L/s)	COOLING				HEATING			
		SUCTION PRESSURE (kPa)	DISCHARGE PRESSURE (kPa)	WATER TEMP RISE (C)	AIR TEMP DROP (C)DB	SUCTION PRESSURE (kPa)	DISCHARGE PRESSURE (kPa)	WATER TEMP DROP (C)	AIR TEMP RISE (C)
-3.8	0.76	—	—	—	—	469-579	1766-2159	2.8-3.9	10.6-12.8
	1.01	—	—	—	—	503-614	1800-2200	2.2-2.8	11.1-13.9
6.2	0.76	807-986	1255-1531	8.3-10.6	11.7-14.4	559-683	1910-2338	3.9-4.4	12.2-14.4
	1.01	786-959	1172-1435	6.1-7.8	12.2-15.0	593-724	1952-2386	2.8-3.3	12.8-15.6
16.2	0.76	828-1014	1483-1814	8.3-10.0	11.1-13.9	641-786	2062-2517	4.4-5.0	13.3-16.1
	1.01	807-986	1386-1697	6.1-7.8	11.7-14.4	683-835	2104-2573	3.3-3.9	13.9-17.2
26.2	0.76	848-1035	1710-2097	7.8-9.4	11.1-13.3	731-890	2214-2704	5.0-6.1	14.4-17.8
	1.01	821-1007	1600-1959	6.1-7.2	11.7-13.9	779-952	2255-2759	3.9-4.4	15.6-18.9
36.2	0.76	869-1062	1945-2343	7.8-9.4	10.6-13.3	814-1000	2359-2883	5.6-6.7	16.1-19.4
	1.01	841-1028	1814-2221	5.6-7.2	11.1-13.9	869-1062	2407-2945	4.4-5.0	16.7-20.6
46.2	0.76	890-1083	2173-2655	7.2-8.9	10.6-12.8	904-1104	2511-3062	6.1-7.8	17.2-21.1
	1.01	862-1055	2028-2483	5.6-6.7	10.6-13.3	959-1172	2559-3131	4.4-5.6	18.3-22.2
56.2	0.76	910-1110	2400-2938	7.2-8.9	10.0-12.2	986-1207	2655-3248	6.7-8.3	18.3-22.8
	1.01	883-1076	2248-2745	5.6-6.7	10.6-12.8	1048-1283	2711-3311	5.0-6.1	19.4-23.9
66.2	0.76	924-1131	2635-3214	6.7-8.3	9.4-11.7	—	—	—	—
	1.01	904-1104	2462-3007	5.0-6.1	10.0-12.2	—	—	—	—

LEGEND

DB — Dry Bulb
 — — No Operation in This Temperature Range

Flow Regulation — Flow regulation can be accomplished by two methods. Most water control valves have a flow adjustment built into the valve. By measuring the pressure drop through the unit heat exchanger, the flow rate can be determined. Adjust the water control valve until the flow of 0.09464 to 0.1262 L/s is achieved. Since the pressure constantly varies, two pressure gages may be needed in some applications.

An alternative method is to install a flow control device. These devices are typically an orifice of plastic material designed to allow a specified flow rate that are mounted on the outlet of the water control valve. Occasionally these valves produce a velocity noise that can be reduced by applying some back pressure. To accomplish this, slightly close the leaving isolation valve of the well water setup.

⚠ WARNING

To avoid possible injury or death due to electrical shock, open the power supply disconnect switch and secure it in an open position before flushing system.

Flushing — Once the piping is complete, units require final purging and loop charging. A flush cart pump of at least 1.1 kW is needed to achieve adequate flow velocity in the loop to purge air and dirt particles from the loop. Flush the loop in both directions with a high volume of water at a high velocity. Follow the steps below to properly flush the loop:

1. Verify power is off.
2. Fill loop with water from hose through flush cart before using flush cart pump to ensure an even fill. Do not allow the water level in the flush cart tank to drop below the pump inlet line to prevent air from filling the line.

3. Maintain a fluid level in the tank above the return tee to avoid air entering back into the fluid.
4. Shutting off the return valve that connects into the flush cart reservoir will allow 345 kPa surges to help purge air pockets. This maintains the pump at 345 kPa.
5. To purge, keep the pump at 345 kPa until maximum pumping pressure is reached.
6. Open the return valve to send a pressure surge through the loop to purge any air pockets in the piping system.
7. A noticeable drop in fluid level will be seen in the flush cart tank. This is the only indication of air in the loop.
NOTE: If air is purged from the system while using a 254 mm PVC flush tank, the level drop will only be 25.4 to 50.8 mm since liquids are incompressible. If the level drops more than this, flushing should continue since air is still being compressed in the loop. If level is less than 25.4 to 50.8 mm, reverse the flow.
8. Repeat this procedure until all air is purged.
9. Restore power.

Antifreeze may be added before, during or after the flushing process. However, depending on when it is added in the process, it can be wasted. Refer to the Antifreeze section for more detail.

Loop static pressure will fluctuate with the seasons. Pressures will be higher in the winter months than during the warmer months. This fluctuation is normal and should be considered when charging the system initially. Run the unit in either heating or cooling for several minutes to condition the loop to a homogenous temperature.

When complete, perform a final flush and pressurize the loop to a static pressure of 276 to 345 kPa for winter months or 103 to 138 kPa for summer months.

After pressurization, be sure to remove the plug from the end of the loop pump motor(s) to allow trapped air to be discharged and to ensure the motor housing has been flooded. Be sure the loop flow center provides adequate flow through the unit by checking pressure drop across the heat exchanger. Compare the results to the data in Tables 27 and 28.

Table 27 — Water Coil Volume

50PC UNIT SIZE	Coaxial Coil Volume (gal)	Coaxial Coil Volume (liters)
009	0.06	0.23
012	0.08	0.30
015	0.09	0.34
018	0.14	0.53
024	0.14	0.53
030	0.24	0.91
036	0.27	1.02
042	0.27	1.02
048	0.49	1.85
060	0.62	2.35
070	0.62	2.35

Table 28 — Water Side Pressure Drop

50PC UNIT SIZE	L/s	WATER SIDE PRESSURE DROP WITHOUT INTERNAL VALVE (kPa)
009	0.13	11.7
	0.16	17.4
	0.19	24.2
012	0.16	17.9
	0.19	24.8
	0.22	32.8
015	0.19	26.8
	0.25	45.0
	0.32	67.3
018	0.25	18.5
	0.32	27.6
	0.38	38.3
024	0.25	19.3
	0.38	40.0
	0.50	67.1
030	0.32	20.7
	0.47	43.0
	0.57	59.6
036	0.38	17.9
	0.57	37.2
	0.76	62.5
042	0.44	25.0
	0.63	47.6
	0.82	76.3
048	0.50	9.3
	0.76	19.4
	0.95	29.0
060	0.63	16.0
	0.95	33.2
	1.14	46.0
070	0.69	19.9
	1.01	39.0
	1.14	48.2

NOTE: All values based on pure water at 21.1°C.

Antifreeze — In areas where entering loop temperatures drop below 4.4°C or where piping will be routed through areas subject to freezing, antifreeze is needed.

Alcohols and glycols are commonly used as antifreeze agents. Freeze protection should be maintained to 9.5°C below the lowest expected entering loop temperature. For example, if the lowest expected entering loop temperature is -1.1°C, the leaving loop temperature would be -5.6 to -3.9. Therefore, the freeze protection should be at -10.6°C (01501.1°C - -9.5°C = -10.6°C).

IMPORTANT: All alcohols should be pre-mixed and pumped from a reservoir outside of the building or introduced under water level to prevent fuming.

Calculate the total volume of fluid in the piping system. See Table 29. Use the percentage by volume in Table 30 to determine the amount of antifreeze to use. Antifreeze concentration should be checked from a well mixed sample using a hydrometer to measure specific gravity.

FREEZE PROTECTION SELECTION — The -1.1°C FP1 factory setting (water) should be used to avoid freeze damage to the unit.

Once antifreeze is selected, the JW3 jumper (FP1) should be clipped on the control to select the low temperature (antifreeze -10.6°C) set point to avoid nuisance faults.

Cooling Tower/Boiler Systems — These systems typically use a common loop temperature maintained at 15.6 to 32.2°C. Carrier recommends using a closed circuit evaporative cooling tower with a secondary heat exchanger between the tower and the water loop. If an open type cooling tower is used continuously, chemical treatment and filtering will be necessary.

Table 29 — Approximate Fluid Volume (L) per 30.48 m of Pipe

PIPE	DIAMETER	VOLUME
	mm	L
Copper	25.40	15.52
	31.75	24.23
	38.10	34.83
Rubber Hose	25.40	14.76
Polyethylene	19.05	10.60
	25.40	17.03
	31.75	30.28
	12.70	41.26
	50.80	68.14
	31.75	31.42
	38.10	41.26
50.80	64.35	

NOTE: Volume of heat exchanger is approximately 3.785 L.

Table 30 — Antifreeze Percentages by Volume

ANTIFREEZE	MINIMUM TEMPERATURE FOR FREEZE PROTECTION			
	-12°C	-9.4°C	-6.67°C	-3.89°C
Methanol (%)	25	21	16	10
100% USP Food Grade Propylene Glycol (%)	38	30	22	15
Ethanol (%)	29	25	20	14

OPERATION

Power Up Mode — The unit will not operate until all the inputs, terminals and safety controls are checked for normal operation.

NOTE: The compressor will have a 5-minute anti-short cycle upon power up.

IMPORTANT: If the installer or service provider adjusts the unit refrigerant charge from the factory charge levels, it must be noted on the unit label and in related documentation as required by EU Regulation (517/2014).

SERVICE

Perform the procedures outlined below periodically, as indicated.

An annual “checkup” by a licensed refrigeration mechanic is recommended. Recording the performance measurements of volts, amps, and water temperature differences (both heating and cooling) is recommended. This data should be compared to the information on the unit’s data plate and the data taken at the original start-up of the equipment.

Periodic lockouts almost always are caused by air or water flow problems. The lockout (shutdown) of the unit is a normal protective measure in the design of the equipment. If continual lockouts occur, call a mechanic immediately to check for water flow problems, water temperature problems, airflow problems or air temperature problems. Use of the pressure and temperature charts for the unit may be required to properly determine the cause.

IMPORTANT: When a compressor is removed from this unit, system refrigerant circuit oil will remain in the compressor. To avoid leakage of compressor oil, the refrigerant lines of the compressor must be sealed after it is removed.

IMPORTANT: All refrigerant discharged from this unit must be recovered without exception. Technicians must follow industry accepted guidelines and all local, state and federal statutes for the recovery and disposal of refrigerants.

IMPORTANT: To avoid the release of refrigerant into the atmosphere, the refrigerant circuit of this unit must only be serviced by technicians who meet local, state and federal proficiency requirements.

IMPORTANT: To prevent injury or death due to electrical shock or contact with moving parts, open unit disconnect switch before servicing unit.

Filters — Filter changes or cleanings are required at regular intervals. The time period between filter changes will depend upon the type of environment the equipment is used in. In a single family home that is not under construction, changing or cleaning the filter every 60 days may be sufficient. In other applications such as motels, where daily vacuuming produces a large amount of lint, filter changes may be needed to be as frequent as biweekly. See Fig. 1 and 2 for replacement filter sizes. Note that horizontal units containing two filters are taped together at the factory to facilitate removal. This should be done by end user as new filters are installed.

IMPORTANT: Units should never be operated without a filter.

CAUTION

Equipment should never be used during construction due to likelihood of wall board dust accumulation in the air coil of the equipment which permanently affects the performance and may shorten the life of the equipment.

Condensate Drain Pans — The condensate drain should be checked annually by cleaning and flushing to ensure proper drainage.

Refrigerant System — Verify air and water flow rates are at proper levels before servicing. To maintain sealed circuitry integrity, do not install service gages unless unit operation appears abnormal.

Check to see that unit is within the superheat and subcooling temperature ranges shown in Tables 16-26. If the unit is not within these ranges, recover and reweigh in refrigerant charge.

Compressor — Conduct annual amperage checks to ensure that amp draw is no more than 10% greater than indicated on the serial plate data.

Fan Motors — All units have lubricated fan motors. Fan motors should never be lubricated unless obvious, dry operation is suspected. Periodic maintenance oiling is NOT recommended as it will result in dirt accumulating in the excess oil and cause eventual motor failure. Conduct annual dry operation check and amperage check to ensure amp draw is no more than 10% greater than indicated on serial plate data.

Condensate Drain Cleaning — Clean the drain line and unit drain pan at the start of each cooling season. Check flow by pouring water into drain. Be sure trap is filled to maintain an air seal.

Air Coil Cleaning — Remove dirt and debris from evaporator coil as required by condition of the coil. A 10% solution of dishwasher detergent and water is recommended for cleaning both sides of the coil, followed by a thorough water rinse. Clean coil with a stiff brush, vacuum cleaner, or compressed air. Use a fin comb of the correct tooth spacing when straightening mashed or bent coil fins.

Condenser Cleaning — Water-cooled condensers may require cleaning of scale (water deposits) due to improperly maintained closed-loop water systems. Sludge build-up may need to be cleaned in an open water tower system due to induced contaminants.

Local water conditions may cause excessive fouling or pitting of tubes. Condenser tubes should therefore be cleaned at least once a year, or more often if the water is contaminated.

Proper water treatment can minimize tube fouling and pitting. If such conditions are anticipated, water treatment analysis is recommended. Refer to the Carrier System Design Manual, Part 5, for general water conditioning information.

CAUTION

Follow all safety codes. Wear safety glasses and rubber gloves when using inhibited hydrochloric acid solution. Observe and follow acid manufacturer's instructions.

Clean condensers with an inhibited hydrochloric acid solution. The acid can stain hands and clothing, damage concrete, and, without inhibitor, damage steel. Cover surroundings to guard against splashing. Vapors from vent pipe are not harmful, but take care to prevent liquid from being carried over by the gases.

Warm solution acts faster, but cold solution is just as effective if applied for a longer period.

GRAVITY FLOW METHOD — Do not add solution faster than vent can exhaust the generated gases.

When condenser is full, allow solution to remain overnight, then drain condenser and flush with clean water. Follow acid manufacturer's instructions. See Fig. 23.

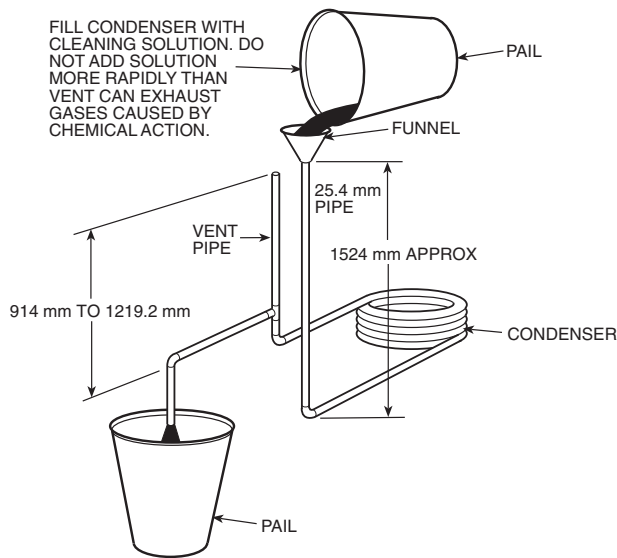

Fig. 23 — Gravity Flow Method

FORCED CIRCULATION METHOD — Fully open vent pipe when filling condenser. The vent may be closed when condenser is full and pump is operating. See Fig. 24.

Regulate flow to condenser with a supply line valve. If pump is a nonoverloading type, the valve may be fully closed while pump is running.

For average scale deposit, allow solution to remain in condenser overnight. For heavy scale deposit, allow 24 hours. Drain condenser and flush with clean water. Follow acid manufacturer's instructions.

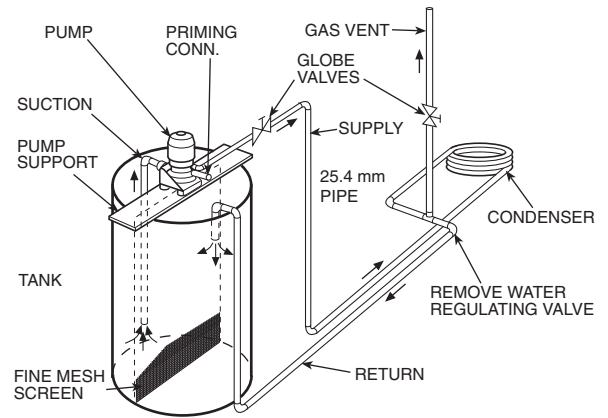

Fig. 24 — Forced Circulation Method

Checking System Charge — Units are shipped with full operating charge.

IMPORTANT: If the refrigerant charge is adjusted from the factory charge levels, it must be noted on the unit label and in related documentation as required by EU Regulation (517/2014).

If recharging is necessary:

1. Insert thermometer bulb in insulating rubber sleeve on liquid line near filter drier. Use a digital thermometer for all temperature measurements. **DO NOT** use a mercury or dial-type thermometer.
2. Connect pressure gage to discharge line near compressor.
3. After unit conditions have stabilized, read head pressure on discharge line gage.

NOTE: Operate unit a minimum of 15 minutes before checking charge.

4. From standard field-supplied Pressure-Temperature chart for R-410A, find equivalent saturated condensing temperature.
5. Read liquid line temperature on thermometer, then subtract from saturated condensing temperature. The difference equals subcooling temperature.
6. Compare the subcooling temperature with the normal temperature listed in Tables 16-26. If the measured liquid line temperature does not agree with the required liquid line temperature, **ADD** refrigerant to raise the temperature or **REMOVE** refrigerant (using standard practices) to lower the temperature (allow a tolerance of $\pm 1.668^\circ\text{C}$).

Refrigerant Charging

WARNING

To prevent personal injury, wear safety glasses and gloves when handling refrigerant. Do not overcharge system — this can cause compressor flooding.

NOTE: Do not vent or depressurize unit refrigerant to atmosphere. Remove and recover refrigerant following accepted practices. See Fig. 25.

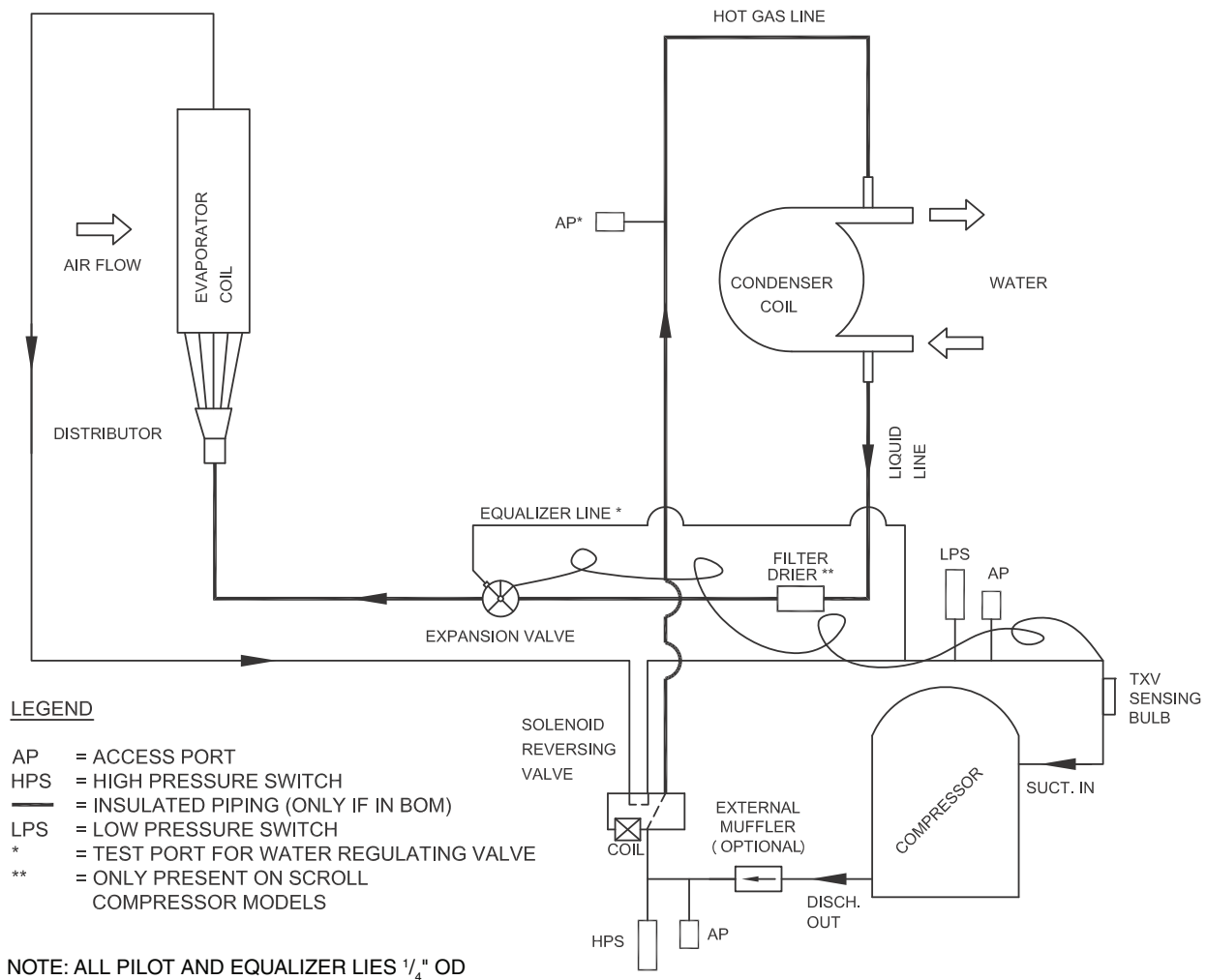

Fig. 25 — Refrigeration Piping Diagram

TROUBLESHOOTING

When troubleshooting problems with a WSHP, consider the following.

Thermistor — A thermistor may be required for single-phase units where starting the unit is a problem due to low voltage. See Fig. 26.

Control Sensors — The control system employs 2 nominal 10,000 ohm thermistors (FP1 and FP2) that are used for freeze protection. Be sure FP1 is located in the discharge fluid and FP2 is located in the air discharge. See Fig. 26.

Thermostatic Expansion Valves — Thermostatic expansion valves (TXV) are used as a means of metering the refrigerant through the evaporator to achieve a preset superheat at the TXV sensing bulb. Correct superheat of the refrigerant is important for the most efficient operation of the unit and for the life of the compressor.

Packaged heat pumps typically use one bi-flow TXV to meter refrigerant in both modes of operation. When diagnosing possible TXV problems it may be helpful to reverse the refrigerant flow to assist with the diagnosis.

Geothermal and water source heat pumps are designed to operate through a wide range of entering-water temperatures that will have a direct effect on the unit refrigerant operating pressures. Therefore, diagnosing TXV problems can be difficult.

TXV FAILURE — The most common failure mode of a TXV is when the valve fails while closed. Typically, a TXV uses spring pressure to close the valve and an opposing pressure, usually from a diaphragm, to open the valve. The amount of pressure exerted by the diaphragm will vary, depending on the pressure inside of the sensing bulb. As the temperature of and pressure within the bulb decreases, the valve will modulate closed and restrict the refrigerant flow through the valve. The result is less refrigerant in the evaporator and an increase in the superheat. As the temperature at the bulb increases the diaphragm pressure will increase, which opens the valve and allows more refrigerant flow and a reduction in the superheat.

If the sensing bulb, connecting capillary, or diaphragm assembly are damaged, pressure is lost and the spring will force the valve to a closed position. Often, the TXV will not close completely so some refrigerant flow will remain, even if inadequate flow remains for the heat pump to operate.

The TXV sensing bulb must be properly located, secured, and insulated as it will attempt to control the temperature of the line to which it is connected. The sensing bulb must be located on a dedicated suction line close to the compressor. On a packaged heat pump, the bulb may be located almost any place on the tube running from the compressor suction inlet to the reversing valve. If the bulb is located on a horizontal section, it should be placed in the 10:00 or 2:00 position for optimal performance.

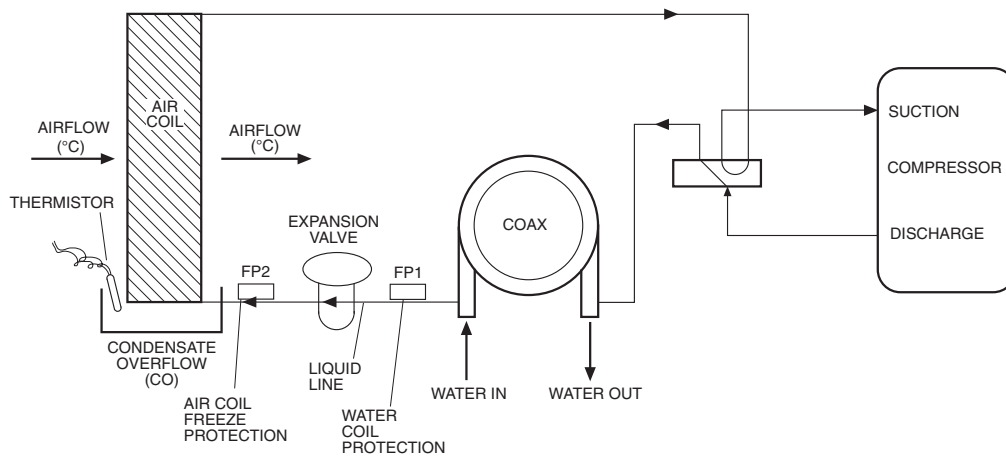

LEGEND
COAX — Coaxial Heat Exchanger
 Airflow
 Refrigerant Liquid Line Flow

Fig. 26 — FP1 and FP2 Thermistor Location

CAUTION

Use caution when tightening the strap. The strap must be tight enough to hold the bulb securely but caution must be taken not to over-tighten the strap, which could dent, bend, collapse or otherwise damage the bulb.

The bulb must be secured to the pipe using a copper strap. The use of heat transfer paste between the bulb and the pipe will also help ensure optimum performance.

The bulb must also be properly insulated to eliminate any influence on valve operation by the surrounding conditions. Cork tape is the recommended insulation as it can be molded tight to the bulb to prevent air infiltration.

Causes of TXV Failure

1. A cracked, broken, or damaged sensing bulb or capillary can be caused by excessive vibration of the capillary during shipping or unit operation.

If the sensing bulb is damaged or if the capillary is cracked or broken, the valve will be considered failed and must be replaced. Replacement of the TXV “power head” or sensing bulb, capillary, diaphragm assembly is possible on some TXVs. The power head assembly screws onto most valves, but not all are intended to be replaceable. If the assembly is not replaceable, replace the entire valve.

2. Particulate debris within the system can be caused by several sources including contaminated components, tubing, and service tools, or improper techniques used during brazing operations and component replacement.

Problems associated with particulate debris can be compounded by refrigerant systems that use POE (polyol ester oil). POE oil has solvent-like properties that will clean the interior surfaces of tubing and components. Particulates can be released from interior surfaces and may migrate to the TXV strainer, which can lead to plugging of the strainer.

3. Corrosive debris within the system may happen after a failure, such as a compressor burn out, if system was not properly cleaned.

4. Noncondensables may be present in the system. Noncondensables includes any substance other than the refrigerant or oil such as air, nitrogen, or water. Contamination can be the result of improper service techniques, use of contaminated components, and/or improper evacuation of the system.

Symptoms — The symptoms of a failed TXV can be varied and will include one or more of the following:

- Low refrigerant suction pressure
- High refrigerant superheat
- High refrigerant subcooling
- TXV and/or low pressure tubing frosting
- Equalizer line condensing and at a lower temperature than the suction line or the equalizer line frosting
- FP1 faults in the heating mode in combination with any of the symptoms listed above
- FP2 faults in the cooling mode in combination with any of the symptoms listed above. Some symptoms can mimic a failed TXV but may actually be caused by another problem.

Before conducting an analysis for a failed TXV the following must be verified:

- Confirm that there is proper water flow and water temperature in the heating mode.
- Confirm that there is proper airflow and temperature in the cooling mode.
- Ensure coaxial water coil is clean on the inside; this applies to the heating mode and may require a scale check.
- Refrigerant may be undercharged. To verify, subcooling and superheat calculations may be required.

Diagnostics—Several tests may be required to determine if a TXV has failed. The following tools may be required for testing:

1. Refrigerant gage manifold compatible with the refrigerant in the system.
2. Digital thermometer, preferably insulated, with wire leads that can be connected directly to the tubing.
3. Refrigerant pressure-temperature chart for the refrigerant used.

To determine that a TXV has failed, verify the following:

- The suction pressure is low and the valve is non-responsive. The TXV sensing bulb can be removed from the suction line and warmed by holding the bulb in your hand. This action should result in an increase in the suction pressure while the compressor is operating. The sensing bulb can also be chilled by immersion in ice water, which should result in a decrease in the suction pressure while the compressor is operating. No change in the suction pressure would indicate a nonresponsive valve.
- Simultaneous LOW suction pressure, HIGH refrigerant subcooling and HIGH superheat.
- LOW suction pressure, LOW subcooling and HIGH superheat may indicate an undercharge of refrigerant. HIGH subcooling and LOW superheat may indicate an overcharge of refrigerant. The suction pressure will usually be normal or high if there is an overcharge of refrigerant.
- LOW suction pressure and frosting of the valve and/or equalizer line may indicate a failed valve. However, these symptoms may also indicate an undercharge of refrigerant. Calculate the subcooling and superheat to verify a failed valve or refrigerant charge issue.

Repair

⚠ WARNING

Puron® refrigerant (R-410A) operates at higher pressure than R-22, which is found in other WSHPs. Tools such as manifold gages must be rated to withstand the higher pressures. Failure to use approved tools may result in a failure of tools, which can lead to severe damage to the unit, injury or death.

⚠ WARNING

Most TXVs are designed for a fixed superheat setting and are therefore considered non-adjustable. Removal of the bottom cap will not provide access for adjustment and can lead to damage to the valve or equipment, unintended venting of refrigerant, personal injury, or possibly death.

⚠ CAUTION

Always recover the refrigerant from the system with suitable approved tools, recovery equipment, and practices prior to attempting to remove or repair any TXV.

⚠ CAUTION

Use caution when tightening the strap. The strap must be tight enough to hold the bulb securely but caution must be taken not to over-tighten the strap, which could dent, bend, collapse or otherwise damage the bulb.

⚠ CAUTION

Puron® refrigerant (R-410A) requires the use of synthetic lubricant (POE oil). Do not use common tools on systems that contain R-22 refrigerants or mineral oil. Contamination and failure of this equipment may result.

IMPORTANT: Due to the hygroscopic nature of the POE oil in Puron refrigerant (R-410A) and other environmentally balanced refrigerants, any component replacement must be conducted in a timely manner using caution and proper service procedure for these types of refrigerants. A complete installation instruction will be included with each replacement TXV/filter drier assembly. It is of critical importance these instructions are carefully understood and followed. Failure to follow these instructions can result in a system that is contaminated with moisture to the extent that several filter drier replacements may be required to properly dry the system.

IMPORTANT: Repair of any sealed refrigerant system requires training in the use of refrigeration tools and procedures. Repair should only be attempted by a qualified service technician. A universal refrigerant handling certificate will be required. Local and/or state license or certificate may also be required.

See Table 31 for additional troubleshooting information.

⚠ CAUTION

Disconnect power from unit before removing or replacing connectors, or servicing motor. Wait 5 minutes after disconnecting power before opening motor.

Disposal of Unit

NOTE: If you want to dispose of this equipment, **DO NOT** use the ordinary trash receptacle! This product contains fluorinated greenhouse gases and lead.

In the European Union used electrical and electronic equipment must be treated separately and in accordance with legislation that requires proper treatment, recovery and recycling of used electrical and electronic equipment.

Following the implementation by member states, private households within the EU states may return their used electrical and electronic equipment to designated collection facilities, free of charge. In some countries, your local retailer may also take back your old products free of charge, if you purchase a similar new unit.

If your used electrical or electronic equipment has batteries or accumulators, please dispose of these separately beforehand according to local requirements.

By disposing of this product correctly you will help ensure that the waste undergoes the necessary treatment, recovery and recycling, thus preventing potential negative effects on the environment and human health which could otherwise arise due to inappropriate waste handling.

Please contact your local authority for further details.

Table 31 — Troubleshooting

FAULT	COOLING	HEATING	CHECK	POSSIBLE CAUSE	SOLUTION	
No Compressor Operation but Fan Runs	X		Is fault LED Blinking 1 time?	High Pressure fault - no or low water flow	Check water valves and/or pumps for proper operation. Check for water coil blockage.	
				High Pressure fault - high water temperature	Check water temperature - is it in range?	
				High Pressure fault - fouled or scaled water coil	Check for proper flow rate and water temperature, but low water side temp rise in cooling.	
			X		High Pressure fault - no or low airflow	Check fan motor for proper operation. Check air filter. Inspect air coil for dirt/debris. Check ductwork - are dampers closed or blocked?
	X		Is fault LED Blinking 2 times?	Low Pressure fault - no or low airflow	Check fan motor for proper operation. Check air filter Inspect air coil for dirt/debris Check ductwork - are dampers closed or blocked?	
				Low Pressure fault - low refrigerant	Check refrigerant pressure with gage set	
				Low Pressure fault - no or low water flow	Check water valves and/or pumps for proper operation. Check for water coil blockage.	
			X		Low Pressure fault - low refrigerant	Check for proper flow rate and water temperature, but low water side temp drop in heating.
			Is fault LED Blinking 3 times?	Freeze fault, water coil - no or low water flow	Check water valves and/or pumps for proper operation. Check for water coil blockage.	
				Freeze fault - low water temperature	Check water temperature - is it below 4.4°C entering? If heat pump is connected to a closed loop with anti-freeze check that the "FREEZE 1" resistor on the Complete C board has been cut to set the unit to anti-freeze mode.	
				Freeze fault - low refrigerant	Check refrigerant pressure with gage set	
	X		Is fault LED Blinking 4 times?	Condensate fault - poor drainage	Check condensate pan for high water level. Check drain line for blockages, double trapping or inadequate trapping.	
				Condensate fault - blocked return air	Check condensate pan for high water level. Check air filter and return air ductwork for blockage. Check that there is adequate space between the return air opening and walls or other obstructions on free return applications.	
	X	X	Is fault LED Blinking 5 times?	Brown out fault - low supply voltage	Check primary voltage - ensure it is within the limits listed on the unit data plate.	
				Brown out fault - overloaded control circuit	Check control voltage - if it is below 18 V check accessories connected to the unit and insure that they do not exceed the VA draw shown on page 14.	
				Brown out fault - bad thermostat connection	Check that thermostat wiring is proper gage and length, that it is not damaged and that all connections at the thermostat and heat pump are secure.	
	X		Is fault LED Blinking 6 times?	Freeze fault, air coil - no or low airflow	Check fan motor for proper operation. Check air filter Inspect air coil for dirt/debris Check ductwork - are dampers closed or blocked?	
				Freeze fault, air coil - blocked return air	Check that there is adequate space between the return air opening and walls or other obstructions on free return applications.	
				Freeze fault, air coil - low refrigerant	Check refrigerant pressure with gage set.	
	X	X	No fault LED - contactor not energized	Thermostat not calling for compressor operation	Ensure that the thermostat is on and calling for "Y" .	
				Bad thermostat connection	Check "Y" connection from thermostat. Ensure that there is 24 VAC between "Y" and "C" .	
				Loose wire to contactor coil	Check wiring - ensure that there is 24 VAC across the contactor coil.	
				Burned out contactor coil	Test contactor with 24VAC (between "R" and "C"). Ohm contactor coil - an open circuit indicates a burned coil.	
	X	X	No fault LED - contactor energized	Open compressor overload	Check for supply voltage at the load side of the contactor. For 3 phase models check phase rotation and voltage at all 3 phases.	
Poor wiring connections				Look for signs of heat on the wiring insulation. Check that all wiring connections are secure and properly torqued.		
Burned out compressor				Does compressor hum when power is applied? If not check the resistance of the compressor windings using the values shown in the compressor characteristics chart. Note that the compressor must be cool (21.1°C) when checking the windings.		

Table 31 —Troubleshooting (cont)

FAULT	COOLING	HEATING	CHECK	POSSIBLE CAUSE	SOLUTION
No compressor or fan operation	X	X	Power LED on	Bad thermostat connection / faulty thermostat	Check thermostat and wiring. Check unit terminal block for 24 VAC between "Y" and "C" and "G" and "C".
			Power LED off	Low or no supply power	Ensure that the supply voltage to the unit is within the range shown on the unit data plate.
				Faulty control transformer	Check for 24 VAC between "R" and "C" on the unit terminal block. For 75 and 100 VA transformers, check that the transformer circuit breaker has not tripped. Check low voltage circuit for overload conditions or short circuits before replacing the transformer.
No fan operation - PSC motor	X	X	Fan relay energized	Faulty motor	Check supply voltage from the fan relay to the motor. Check that all motor wires are secure. With power off spin the motor shaft - noise, resistance or uneven motion can be signs of motor failure.
			Fan relay not energized	No fan operation signal	Check for 24 VAC across the fan relay coil. Check all wiring connections.
				Bad fan relay	If the relay coil is energized but the relay does not pull in, check the resistance across the relay coil - an open circuit is an indicator of a faulty relay.
No fan operation - constant torque motor	X	X	No fan operation signal	Check for 24 VAC between "G" and "C". Check all wiring connections.	
			Loose wiring	Check all wiring connections at motor and control box.	
			Faulty motor	Check supply voltage to the motor. Check that all motor wires are secure. With power off spin the motor shaft - noise, resistance or uneven motion can be signs of motor failure.	
No fan operation - constant airflow motor	X	X	No fan operation signal	Check for 24 VAC between "G" and "C". Check all wiring connections. Make sure that the thermostat connection plug is securely connected.	
			Loose wiring	Check all wiring connections at motor and control box. Check that power and control harnesses are securely connected.	
			Interface board problems	Make sure that the interface board is not damaged and that all DIP switches are in the proper configuration (refer to the blower performance tables).	
			Faulty motor	Check supply voltage to the motor. Check that all motor wires are secure. Move the "TEST" DIP switch to "ON" and the other switches to "OFF" on the "ADJUST" switch block on the interface board - the motor should run at 70% torque when "G" is called. With power off spin the motor shaft - noise, resistance or uneven motion can be signs of motor failure.	
Unit not shifting into cooling	X		Reversing valve solenoid energized	Faulty solenoid	Check that the reversing valve solenoid is receiving 24 VAC. If so, check the resistance of the solenoid - an open circuit may indicate a burned out solenoid.
			Reversing valve solenoid not energized	Miswired/faulty thermostat	Check that the reversing valve thermostat wire is connected to the "O" terminal of the thermostat. Check for a contact closure between "O" and "R".
				Loose wire on "O" terminal	Check that the wires from the thermostat to the unit are securely connected and that the wires from the electrical box to the reversing valve are connected.
Excessively cold supply air temperature in cooling or excessively hot supply air temperature in heating	X	X	Reduced airflow	Dirty Filter	Replace filter.
				Fan speed too low	Consult blower performance table and increase fan speed if possible.
				Excessive duct pressure drop	Consult blower performance table and increase fan speed if possible.
Excessively warm supply air temperature in cooling and/or excessively cool air in heating	X	X	Airflow too high	Fan speed setting too high	Consult blower performance table and reduce fan speed if possible.
			High or low water temperature	Inlet water temperature out of range	Check unit capacity vs. water temperature.
			Air leakage	Leaky ductwork	Inspect ductwork.
			Loss of refrigeration capacity	Low refrigerant	Check refrigerant pressures with gage set.
High humidity	X		Airflow too high	Fan speed setting too high	Consult blower performance table and reduce fan speed if possible.
			Loss of refrigeration capacity	Low refrigerant	Check refrigerant pressures with gage set.
			Short cycling	Unit oversized	Check unit performance against building load calculations.
				Poor thermostat location	Make sure that thermostat is not located by a supply-air duct.

Table 31 —Troubleshooting (cont)

FAULT	COOLING	HEATING	CHECK	POSSIBLE CAUSE	SOLUTION
High humidity	X		Airflow too high	Fan speed setting too high	Consult blower performance table and reduce fan speed if possible.
			Loss of refrigeration capacity	Low refrigerant	Check refrigerant pressures with gage set.
			Short cycling	Unit oversized	Check unit performance against building load calculations.
Poor thermostat location	Make sure that thermostat is not located by a supply-air duct.				
Objectionable noise levels	X	X	Air noise	Poor ductwork/grille design	Ensure ductwork and grilles are properly sized for unit airflow.
				Fan speed setting too high	Consult blower performance table and reduce fan speed if possible.
			Structure-borne noise	Unit not mounted on full vibration pad	Mount unit on a vibration pad.
				Unit not connected with flexible conduit, water lines and/or ductwork	Install unit in accordance with instructions.
	Unit cabinet touching wall or other building component	Adjust unit location to avoid unit touching structure.			
	X		Compressor noise	High water temperature or low water flow rate elevating head pressure	Increase water flow rate and/or reduce water temperature if possible.
				Scaled or fouled water coil elevating heat pressure	Clean/descale water coil.
		X		Low airflow elevating head pressure	Check filter. Increase fan speed.
X	X	Water hammer	Fast closing valves installed	Change valves to slow-close type.	

**50PCH,PCV
START-UP CHECKLIST**

NOTE: To avoid injury to personnel and damage to equipment or property when completing the procedures listed in this start-up checklist, use good judgment, follow safe practices, and adhere to the safety considerations/information as outlined in preceding sections of this Installation, Start-Up, and Service Instructions document.

CUSTOMER: _____ JOB NAME: _____
MODEL NO.: _____ SERIAL NO.: _____ DATE: _____

I. PRE-START-UP

DOES THE UNIT VOLTAGE CORRESPOND WITH THE SUPPLY VOLTAGE AVAILABLE? (Y/N) _____

HAVE THE POWER AND CONTROL WIRING CONNECTIONS BEEN MADE AND TERMINALS TIGHT?
(Y/N) _____

HAVE WATER CONNECTIONS BEEN MADE AND IS FLUID AVAILABLE AT HEAT EXCHANGER?
(Y/N) _____

HAS PUMP BEEN TURNED ON AND ARE ISOLATION VALVES OPEN? (Y/N) _____

HAS CONDENSATE CONNECTION BEEN MADE AND IS A TRAP INSTALLED? (Y/N) _____

IS AN AIR FILTER INSTALLED? (Y/N) _____

II. START-UP

IS FAN OPERATING WHEN COMPRESSOR OPERATES? (Y/N) _____

IF 3-PHASE SCROLL COMPRESSOR IS PRESENT, VERIFY PROPER ROTATION PER INSTRUCTIONS.
(Y/N) _____

UNIT VOLTAGE — COOLING OPERATION

PHASE AB VOLTS _____ PHASE BC VOLTS _____ PHASE CA VOLTS _____
(if 3 phase) (if 3 phase)

PHASE AB AMPS _____ PHASE BC AMPS _____ PHASE CA AMPS _____
(if 3 phase) (if 3 phase)

CONTROL VOLTAGE

IS CONTROL VOLTAGE ABOVE 21.6 VOLTS? (Y/N) _____
IF NOT, CHECK FOR PROPER TRANSFORMER CONNECTION.

TEMPERATURES

FILL IN THE ANALYSIS CHART ATTACHED.

COAXIAL HEAT EXCHANGER	COOLING CYCLE: FLUID IN _____ C	FLUID OUT _____ C	_____ kPa	_____ FLOW
	HEATING CYCLE: FLUID IN _____ C	FLUID OUT _____ C	_____ kPa	_____ FLOW
AIR COIL	COOLING CYCLE: AIR IN _____ C	AIR OUT _____ C		
	HEATING CYCLE: AIR IN _____ C	AIR OUT _____ C		

HEATING CYCLE ANALYSIS

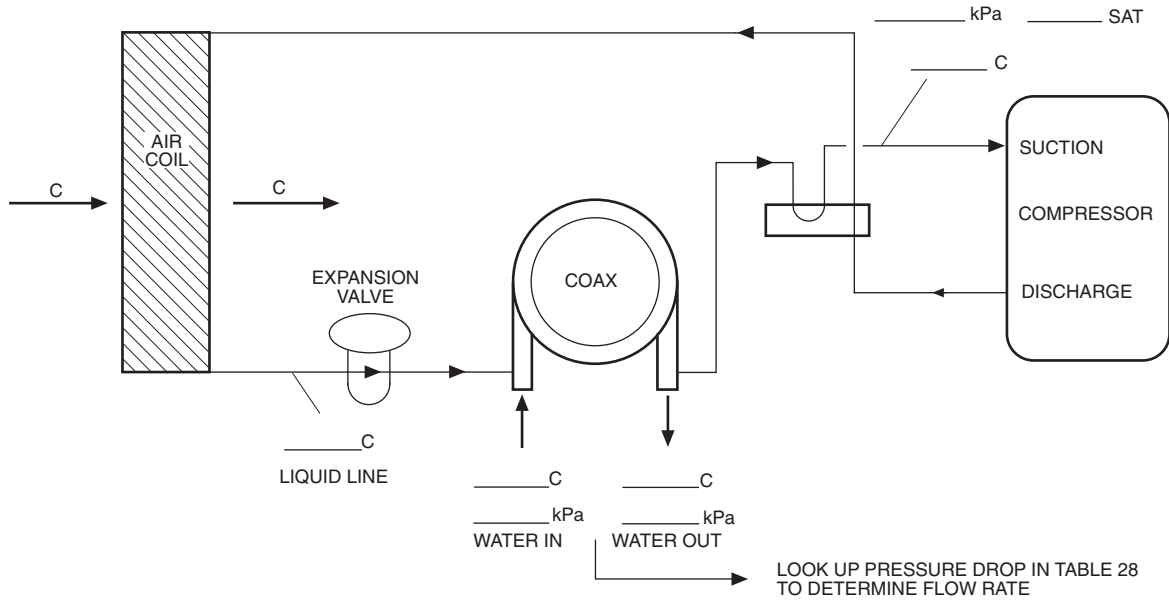

COOLING CYCLE ANALYSIS

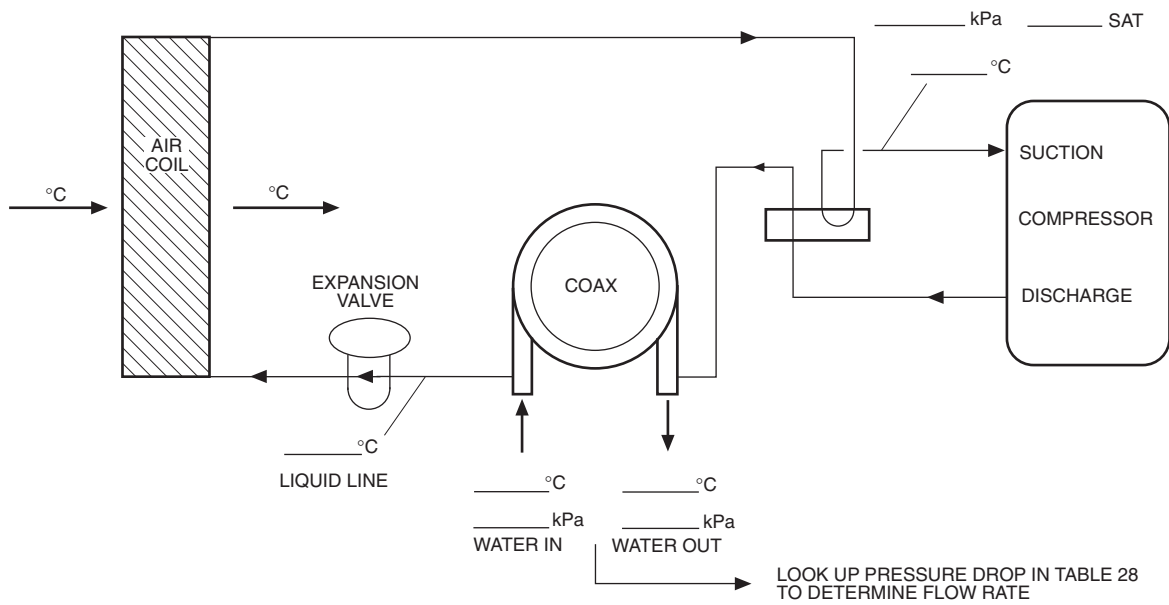

HEAT OF EXTRACTION (ABSORPTION) OR HEAT OF REJECTION =

_____ FLOW RATE (L/S) x _____ TEMP. DIFF. (DEG. C) x _____ FLUID FACTOR* = _____
 (Btu/hr)

SUPERHEAT = SUCTION TEMPERATURE – SUCTION SATURATION TEMPERATURE
 = _____ (DEG. C)

SUBCOOLING = DISCHARGE SATURATION TEMPERATURE – LIQUID LINE TEMPERATURE
 = _____ (DEG. C)

*Use 500 for water, 485 for antifreeze.