



# Installation and Operating Instructions

Part Number 50QE900-511WS

**IMPORTANT:** Read entire instructions before starting the installation.

## SAFETY CONSIDERATIONS

Read and follow manufacturer instructions carefully. Follow all local electrical codes during installation. All wiring must conform to local and national electrical codes. Improper wiring or installation may damage thermostat.

Recognize safety information. This is the safety alert symbol . When the safety alert symbol is present on equipment or in the instruction manual, be alert to the potential for personal injury.

Understand the signal words DANGER, WARNING, and CAUTION. These words are used with the safety alert symbol. DANGER identifies the most serious hazards which will result in severe personal injury or death. WARNING signifies a hazard which could result in personal injury or death. CAUTION is used to identify unsafe practices which would result in minor personal injury or property damage.

## GENERAL

The 50QE900-511WS commercial, programmable thermostat is a wall-mounted, low-voltage thermostat which maintains room temperature by controlling the operation of an HVAC (heating, cooling and ventilation) system. Separate heating and cooling set points and auto-changeover capability allow occupied and unoccupied programming for energy savings.

This thermostat allows up to 4 time/temperature settings to be programmed per 24-hour period. Each thermostat stores programs for 3 different days (Saturday, Sunday, and Monday through Friday). Batteries are not required. During power interruption the internal NEVERLOST™ memory stores programmed schedules for an unlimited time while the clock continues to run for at least 48 hours.

The thermostat can be configured to accept several different equipment configurations, and is provided for heat pump operation.

## INSTALLATION

**Select Thermostat Location** — The thermostat should be mounted:

- approximately 5 ft from the floor
- close to or in a frequently used room, preferably on an inside partitioning wall
- on a section of wall without pipes or ductwork
- where temperature operating limits are within 41 to 104 F (5 to 40 C)
- where humidity operating range is within 0 to 95% relative humidity, non-condensing

The thermostat should **NOT** be mounted:

- close to a window, on an outside wall, or next to a door leading to the outside
- where exposed to direct light and heat from a lamp, the sun, a fireplace, or any other temperature-radiating object which may cause a false reading
- close to or in direct airflow from supply registers or return-air grilles
- in areas with poor air circulation (such as behind a door or in an alcove)

## Install Thermostat

**⚠ WARNING**

Before installing thermostat, turn off all power to the unit. There may be more than one power disconnect. Electrical shock can cause injury or death.

1. Turn off all power to unit.
2. If an existing thermostat is being replaced:
  - a. Remove existing thermostat from the wall.
  - b. Disconnect wires from existing thermostat. Do not allow wires to fall back into the wall. As each wire is disconnected, record wire color and terminal connection.
  - c. Discard or recycle old thermostat.

NOTE: Mercury is a hazardous waste and must be disposed of properly.
3. Remove the thermostat cover from wall plate (mounting base) to expose mounting holes. See Fig. 1.

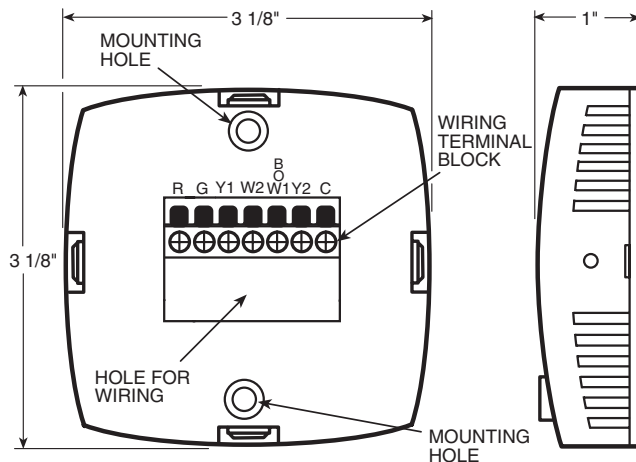

**Fig. 1 — Thermostat Mounting and Wiring**

- Route thermostat wires through large hole in mounting base. Remove outer sheath from wires for added flexibility. Standard solid or multi-conductor thermostat wire should be used from the thermostat to the unit. **Size and length considerations are as follows: for a maximum distance from unit of 36 ft, use 22 AWG (American Wire Gage) wire; for a maximum distance from unit of 100 ft, use 18 AWG wire.**
- Level mounting base against wall and mark wall through the 2 mounting holes in base.
- Drill two  $\frac{3}{16}$ -in. mounting holes in wall where marked.

### ⚠ WARNING

Be careful not to drill into wiring in wall. Electrical shock could result.

- Secure mounting base to wall with 2 screws and anchors provided. Ensure all wires exit through hole in mounting base.
- Adjust wire length and routing to allow proper closure of the thermostat. Strip each wire at the end no more than  $\frac{1}{4}$ -in. to prevent adjacent wires from shorting together. Match and connect wires to terminals on the thermostat. See Fig. 2-4 and Table 1.

### ⚠ CAUTION

Improper wiring or installation may cause damage to the thermostat. Check to ensure wiring is correct before proceeding with installation of unit.

- Push excess wiring into wall. Seal hole in wall to prevent drafts.
- Re-attach thermostat cover to back plate.
- Turn on power to unit. The thermostat will receive power from the unit. The thermostat will be powered by 24 v, nominal (18 to 30 vac). Terminals R (+ 24 v), W1/O/B (first stage heat or reversing valve), Y1 (first stage cooling), G (fan relay) and C (common) will always be connected. Some applications will use Y2 (second stage cooling) or W2 (second stage heating).

**Set Clock** — The Mode and Override buttons are used to change the time and day displayed on the thermostat. Press and hold the Mode and Override buttons for 2 seconds to enter the setup screens. The current time will blink on and off. Press the UP ARROW and DOWN ARROW buttons until the correct time is shown. Hold down the buttons to quickly move through the time display. The AM and PM annunciators will automatically change. Hold down the Override button while pressing UP ARROW or DOWN ARROW to change the time by hours instead of minutes. To ensure the schedules are properly followed, make sure that AM or PM is correct for the time chosen. When the correct time is shown, press the Mode button to modify the day of the week. The current day will blink on and off. Press the UP ARROW and DOWN ARROW buttons until the correct day is shown. Press the Mode and Override buttons again to exit the Set Clock mode.

**Heat Pump Configuration** — To configure the thermostat for heat pump operation, Advanced Setup Steps 5 (Heat Pump Operation) and 6 (Reversing Valve Polarity) must be configured correctly. See the Configure Advanced Setup section for information on configuring these options.

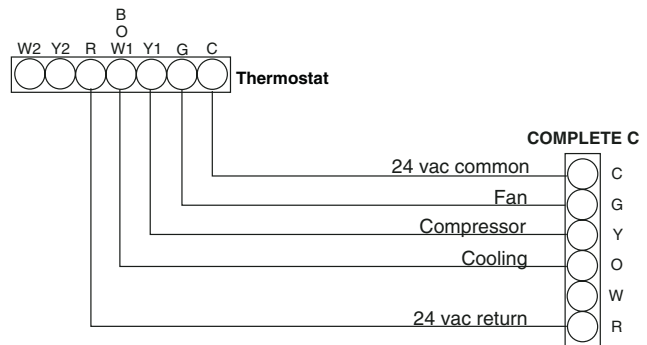

**Fig. 2 — Water Source Heat Pumps Equipped with 1 Complete C Control Board for Single Stage Operation**

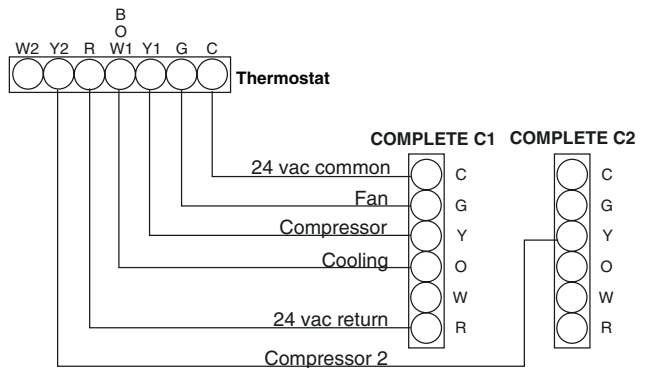

**Fig. 3 — Water Source Heat Pumps Equipped with 2 Complete C Control Boards for Two-Stage Operation**

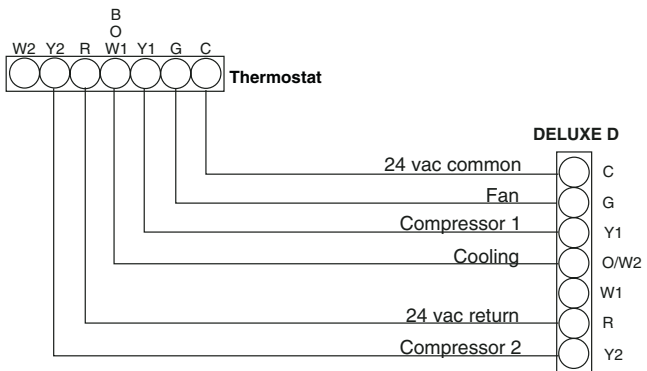

**Fig. 4 — Water Source Heat Pumps Equipped with Deluxe D Control Board(s) for Single or Two-Stage Operation**

**Table 1 — Thermostat Wiring Terminations**

EXISTING WIRE DESIGNATION	FUNCTION	TERMINAL CONNECTION
G or F	Fan	G
Y1, Y, or C	Cooling	Y1
W1, W, or H	Heating	W1/O/B
Rh, R, M, Vr, or A	Power (24 v)	R
C	Common	C
O/B	Reversing Valve†	W1/O/B
Y2	Second Stage Cooling	Y2*
W2	Second Stage Heating	W2*

\*Terminals Y2 and W2 may not be used in all applications.

†Used on Heat Pump applications only.

**Configure Advanced Setup** — To enter the advanced setup screens of the thermostat, press the Mode and Override buttons at the same time for 5 seconds. The Advanced Setup Step number is shown in the top right corner of the thermostat screen. Use the Mode button to advance through the steps. See Table 2. Press the Mode and Override buttons at the same time to exit the Advanced Setup mode.

NOTE: Refer to Set Clock section on page 2 for an explanation of Advanced Setup Steps 1 and 2.

**Table 2 — Advanced Setup Configuration**

STEP	DESCRIPTION	RANGE	DEFAULT
1*	Time of Day	12:00 AM - 11:59 PM	12:00 AM
2*	Day of the Week	Sunday through Saturday	Monday
3	Display Blanking	Off/On	Off
4	Fan Mode	On/Auto	Auto
5	Heat Pump	Off/On	On
6	Reversing Valve Polarity	O/B	O
7	Deadband	1 - 6 degrees	2
8	Forced Minimum Temperature Difference	0 - 6 degrees	2
9	Cycles Per Hour	d, d1, 2 - 6	6
10	Thermoglow™ Backlight	Off/On	On
11	Temperature Units	F/C	F

\*Accessed and configured through the Set Clock Setup function.

**DISPLAY BLANKING (Step 3)** — When Display Blanking is set to OFF, the thermostat will display the time of day, current temperature, and mode normally. When Display Blanking is set to ON, the thermostat will only display time of day. The default is OFF.

**FAN MODE (Step 4)** — The fan mode is used to configure fan operation. If On is selected, the fan will run continuously during the Occupied schedule (except when Mode is switched to OFF). The fan will be off during unoccupied schedule except during heating or cooling operation.

If Auto is selected, the fan will operate only during heating or cooling operation. The default is Auto.

**HEAT PUMP CONFIGURATION (Steps 5 and 6)** — The thermostat is provided from the factory in heat pump mode. To set the thermostat for heat pump operation, Advanced Setup Step 5 must be configured to ON. Use the UP and DOWN ARROW buttons to configure the step. The default is ON. Press the Mode button to continue to Step 6. Step 6 is used to set the reversing valve polarity for the heat pump. The variable can be set to either “B” or “O.” Set the reversing valve polarity to the correct value depending on the application. The default is “O.”

NOTE: Step 6 will appear only if Step 5 is set to ON.

**DEADBAND (Step 7)** — The deadband is the difference in temperature above the cooling set point or below the heating set point that the thermostat will wait before turning on the first stage of heating or cooling. For example, if the cooling set point is 82 F (28 C) and the deadband is 2 degrees, the first stage of cooling will not be energized until the temperature reaches 84 F (30 C). The range of values is 1 to 6 degrees. The default is 2 degrees.

**SET POINT MINIMUM DIFFERENCE (Step 8)** — The minimum difference between heating and cooling set points can be user-configured. The range is from 0 to 6 degrees. The default is 2 degrees. The minimum difference is enforced during Autochangeover and Program On operation.

**CYCLES PER HOUR LIMIT (Step 9)** — The number of times that heating or cooling can be energized per hour can be configured. Set the variable to “d” for no limit. Set the variable to “d1” to disable the 5-minute compressor lockout. The

variable can also be set from 2 to 6 cycles per hour. The default is 6 cycles per hour.

**⚠ CAUTION**

Damage to compressor could result if 5-minute compressor lockout is disabled or compressor is allowed unlimited cycles. Do not set thermostat Advanced Setup Step 9 to “d” or “d1” unless specifically recommended for the application.

**BACKLIGHT DISPLAY (Step 10)** — The display backlight can be set to ON (always on) or OFF (turn off 8 seconds after usage). The default is ON.

**FAHRENHEIT/CELSIUS OPERATION (Step 11)** — The thermostat can be set to operate in Fahrenheit or Celsius degrees. Set the variable to “F” for Fahrenheit operation. Set the variable to “C” for Celsius operation. The default is “F.”

**Program Thermostat Schedules** — Before programming the thermostat, plan the thermostat daily schedule. The schedule is divided into 3 different day schedules: Monday through Friday, Saturday, and Sunday. The schedules for Monday, Tuesday, Wednesday, Thursday, and Friday are the same. Each day has from 2 to 4 time periods (Occupied 1, Occupied 2, Occupied 3, Unoccupied) depending on the configuration of the thermostat. Each occupied time period has a start time, stop time, heating set point, and cooling set point. The unoccupied time period has a heating set point and a cooling set point. The unoccupied time period is active when ever an occupied time period is not active. Fill in Table 3 as an aid to programming the daily schedules.

NOTE: The Occupied 1 and Unoccupied time period temperature set points are the same for each day.

**PROGRAMMING MODE** — To program the daily schedules, perform the following procedure:

1. Enter programming mode by pressing the and holding the Mode and UP ARROW buttons. The Occupied 1 annunciator will appear on the thermostat display. Use the UP ARROW and DOWN ARROW buttons to set the maximum number of Occupied periods for each day. The thermostat can be set to 1, 2, or 3. After the number of Occupied periods has been selected, press the Mode button. See Fig. 5.
2. The cooling set point for Occupied 1 will be displayed. Use the UP ARROW and DOWN ARROW buttons to raise or lower the cooling set point until the desired temperature is shown. The range of acceptable values is 35 to 99 F (1 to 37 C). Press the Mode button to continue. See Fig. 5.
3. The heating set point for Occupied 1 will be displayed. Use the UP ARROW and DOWN ARROW buttons to raise or lower the heating set point until the desired temperature is shown. The range of acceptable values is 35 to 99 F (1 to 37 C). Press the Mode button to continue. See Fig. 5.

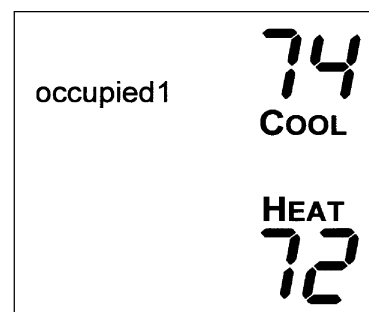

**Fig. 5 — Setting Occupied 1 Set Points**

4. The cooling set point for Unoccupied will be displayed. Use the UP ARROW and DOWN ARROW buttons to raise or lower the cooling set point until the desired temperature is shown. The range of acceptable values is 35 to 99 F (1 to 37 C) or "OF" (no unoccupied cooling). To configure to "OF," press UP ARROW after reaching 99. Press the Mode button to continue.
5. The heating set point for Unoccupied will be displayed. Use the UP ARROW and DOWN ARROW buttons to raise or lower the heating set point until the desired temperature is shown. The range of acceptable values is 35 to 99 F (1 to 37 C) or "OF" (no unoccupied heating). To configure to "OF," press DOWN ARROW after reaching 35. Press the Mode button to continue.
6. The day of the week will be shown. Use the UP ARROW and DOWN ARROW buttons to change the day of the week until the desired starting day is shown. Possible choices are Mo-Fr (Monday through Friday), Sa (Saturday), and Su (Sunday). Press the Mode button when the desired day is shown.
7. The Start Time for Occupied 1 for the chosen day will be displayed. Use the UP ARROW and DOWN ARROW buttons to raise or lower the time until the desired Start Time is shown. Press the Mode button to continue. See Fig. 6.
8. The Stop Time for Occupied 1 for the chosen day will be displayed. Use the UP ARROW and DOWN ARROW buttons to raise or lower the time until the desired Stop Time is shown. Press the Mode button to continue.

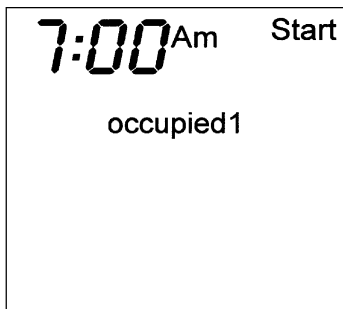

**Fig. 6 — Start Time Display**

9. The On/Off icon will be displayed. Use the UP ARROW to turn the Occupied 1 period ON for this day. Use the DOWN ARROW to turn the Occupied 1 period OFF for this day.
10. If the Occupied 2 and/or Occupied 3 time periods were selected in Step 1, the user is prompted to configure them. Set the cooling set point, heating set point, start time, stop time, and on/off configuration for Occupied 2 and 3 time periods for that day (Sa, Su, Mo-Fr). If the Occupied 2 and 3 time periods were not selected in Step 1, skip to Step 11. Press the Mode button to continue.
11. The program schedule will move forward to the next day (Sa, Su, Mo-Fr). Repeat Steps 7 to 10 for that day schedule.

12. The program will continue to cycle through the 3 schedules (Sa, Su, Mo-Fr) and repeating Steps 7 to 10. Press the Mode and UP ARROW buttons at the same time to exit Programming mode.

NOTE: The thermostat will continue to follow the schedule until a new one is entered.

If only one occupied schedule is selected, the Occupied 2 and 3 schedules are skipped. If the start time is set later in the day than the stop time, the program will run from midnight of that day to the stop time and then from the start time to midnight. If the same start and stop times are programmed for an occupancy schedule, the thermostat will be in Occupied mode for 24 hours. If one occupied period starts or stops within another occupied period, the lower numbered schedule has priority. For example, if schedule Occupied 3 is running for 24 hours and Occupied 2 schedule comes on from 1 to 3 PM, the set points from Occupied 2 are in effect from 1 to 3 PM.

**OVERRIDING THE SCHEDULE** — The schedule can be overridden by pressing the UP or DOWN ARROW buttons to change the desired temperature. The thermostat will use the new set point until the next scheduled time period starts.

**Calibrate Sensor** — Every thermostat is factory calibrated. Under normal circumstances there will never be a need to re-calibrate the thermostat. If re-calibration must be done, perform the following procedure:

1. Hold down the Mode and DOWN ARROW buttons for 5 seconds. All of the icons on the display screen will appear. Release the buttons.
2. Press the Mode button. The current temperature will be displayed.
3. Use an accurate thermometer to measure room temperature. Press the UP or DOWN ARROW buttons until the number equals room temperature.
4. Press the Mode button to return to normal operation.

**Check Thermostat Operation** — To check thermostat operation, perform the following procedure:

1. Press the Mode button repeatedly until the Heat icon appears on the display. The thermostat is now in Heating mode.
2. Press the UP ARROW button until the heating set point is 10 F (6 C) higher than the current room temperature. Heating and fan should be energized.
3. Press the Mode button repeatedly until the Cool icon appears on the display. The thermostat is now in Cooling mode.
4. Press the DOWN ARROW button until the cooling set point is 10 F lower than the current room temperature. Cooling and fan should be energized.
5. If heating, cooling, or fan operation do not energize, check wiring and consult Table 4.

### Final Checklist

1. Put away tools and instruments. Clean up debris and packaging.
2. Review Owner's Guide with occupant or owner.
3. Leave the manuals with owner.

**Table 3 — Daily Schedule Planner**

DAY OF THE WEEK	SCHEDULE											
	Occupied 1			Occupied 2			Occupied 3			Unoccupied		
	Start	Stop	Heat / Cool*	Start	Stop	Heat / Cool	Start	Stop	Heat / Cool	Start	Stop	Heat / Cool*
Monday-Friday	/	/	/	/	/	/	/	/	/	/	/	/
Saturday	/	/	/	/	/	/	/	/	/	/	/	/
Sunday	/	/	/	/	/	/	/	/	/	/	/	/

\*The Heat and Cool temperature set points for Occupied 1 and Unoccupied are the same for every day.

NOTE: The cooling temperature set point must be higher than the heating temperature set point. (The temperature difference may be changed in the advanced set up configuration.)

## OPERATION

The Mode button selects the operating mode of the thermostat. If OFF is selected, the thermostat will not enter Heating or Cooling mode. If HEAT is selected, the thermostat will only enter Heating mode (if the room temperature is below the heating set point). If COOL is selected, the thermostat will only enter Cooling mode (if the room temperature is above the cooling set point). If AUTO is selected, the thermostat will enter Heating or Cooling mode based on the room temperature and the heating and cooling set points. If PROGRAM ON is selected, the stored schedule is enabled and the thermostat will follow the Occupied and Unoccupied schedules stored in its memory.

**Auto-Changeover** — When the thermostat mode is set to AUTO, the thermostat will provide automatic changeover from Heating to Cooling mode and Cooling to Heating mode when required. The thermostat will automatically switch to maintain the desired temperature setting. The thermostat does not need to be manually changed from heating to cooling or cooling to heating operation.

**Two-Stage Operation** — The second stage of heat or cool is turned on when the first stage has been on for a minimum of 2 minutes and the temperature differential from the set point is equal to or greater than the set point plus the deadband plus 2 degrees.

**Clock Backup** — In the event of a power loss, the thermostat will keep time for a minimum of 48 hours without external power or batteries.

**Fan Operation** — If Fan On is selected, the fan will run continuously during occupied schedule (except when Mode is switched to OFF). The fan will be off during unoccupied schedule except during heating or cooling operation.

If Fan On is not selected, the fan will only operate during heating or cooling operation.

**Emergency Heat** — Emergency heat is available for heat pump applications. This option is only available if Advanced Setup Step 5 (Heat Pump) is set to ON. To turn on emergency heat, press and hold the Override button. While holding the Override button, press the UP button. An “EH” will be displayed. During emergency heat, the fan will operate and the second stage of heat will be energized (locking out the first stage compressor). To exit emergency heat, press and hold the Override button. While holding the Override button, press the UP button. During emergency heat, only OFF and HEAT modes are available.

**Keypad Lock** — To prevent unauthorized use of the thermostat, the front panel buttons can be disabled. To disable or lock the keypad, press and hold the Mode button. While holding down the Mode button, press the UP and DOWN ARROW buttons simultaneously. The “Locked” icon will appear on the display.

The thermostat is unlocked by performing the same procedure. Press and hold the Mode button. While holding down the Mode button, press the UP and DOWN ARROW buttons simultaneously. The “Locked” icon will be removed from the display.

## TROUBLESHOOTING

**Table 4 — Troubleshooting**

PROBLEM	SOLUTION
<b>Display on thermostat not illuminated.</b>	Check for 24 vac at the R terminal connection. Terminal R must be connected for proper thermostat operation.
<b>Cooling will not energize.</b>	Select COOL mode. Decrease cooling set point to 10 degrees below room temperature. Check for 24 vac at Y1 terminal. If present, thermostat is operating correctly and problem is with wiring or equipment. If 24 vac is not present, replace the thermostat. Check for Compressor Cycle per Hour Limit. Cooling may be locked out.
<b>Heating will not energize.</b>	Select HEAT mode. Increase heating set point to 10 degrees above room temperature. Check for 24 vac at W1/O/B terminal. If present, thermostat is operating correctly and problem is with wiring or equipment. If 24 vac is not present, replace the thermostat.
<b>When controlling a heat pump, heat comes on during cooling cycle.</b>	Configure thermostat for heat pump operation (Table 2, Step 5).



---

Manufacturer reserves the right to discontinue, or change at any time, specifications or designs without notice and without incurring obligations.

Book	1	4
Tab	5a	5a