



# Installation Instructions

## TABLE OF CONTENTS

SAFETY CONSIDERATIONS .....	1
INSTALLATION .....	1
Step 1 - Provide Unit Support .....	2
Step 2 - Field Fabricate Ductwork .....	2
Step 3 - Install External Trap for Condensate Drain .....	2
Step 4 - Rig and Place Unit .....	4
Step 5 - Make Electrical Connections .....	8
Step 6 - Adjust Factory-Installed Options .....	9
Step 7 - Adjust Evaporator-Fan Speed .....	21
PRE-START-UP .....	28
START-UP .....	28
TROUBLESHOOTING .....	31
START-UP CHECKLIST .....	35


## SAFETY CONSIDERATIONS

Installation and servicing of air-conditioning equipment can be hazardous due to system pressure and electrical components. Only trained and qualified service personnel should install, repair, or service air-conditioning equipment.


Untrained personnel can perform the basic maintenance functions of cleaning coils and filters and replacing filters. All other operations should be performed by trained service personnel. When working on air-conditioning equipment, observe precautions in the literature, tags and labels attached to the unit, and other safety precautions that may apply.

Follow all safety codes. Wear safety glasses and work gloves.

Use quenching cloth for unbrazing operations. Have fire extinguisher available.

Recognize safety information. This is the safety-alert symbol . When you see this symbol on the unit and in instructions or manuals, be alert to the potential for personal injury.


Understand the signal words DANGER, WARNING, and CAUTION. These words are used with the safety-alert symbol. DANGER identifies the most serious hazards which **will** result in severe personal injury or death. WARNING signifies a hazard which **could** result in personal injury or death. CAUTION is used to identify unsafe practices which **may** result in minor personal injury or product and property damage. NOTE is used to highlight suggestions which **will** result in enhanced installation, reliability, or operation.

 **WARNING**

**ELECTRICAL SHOCK HAZARD**

Failure to follow this warning could cause personal injury or death.

Before performing service or maintenance operations on unit, turn off main power switch to unit and install lockout tag. Ensure electrical service to rooftop unit agrees with voltage and amperage listed on the unit rating plate.

 **WARNING**

**UNIT OPERATION AND SAFETY HAZARD**

Failure to follow this warning could cause personal injury, death and/or equipment damage.

Puron (R-410a) refrigerant systems operate at higher pressures than standard R-22 systems. Do not use R-22 service equipment or components on Puron refrigerant equipment.

## INSTALLATION

Unit is shipped in the vertical discharge configuration. To convert to horizontal configuration, remove screws from side duct opening covers and remove covers. Using the same screws, install covers on vertical duct openings with the insulation-side down. Seals around duct openings must be tight. (See Fig. 1.)

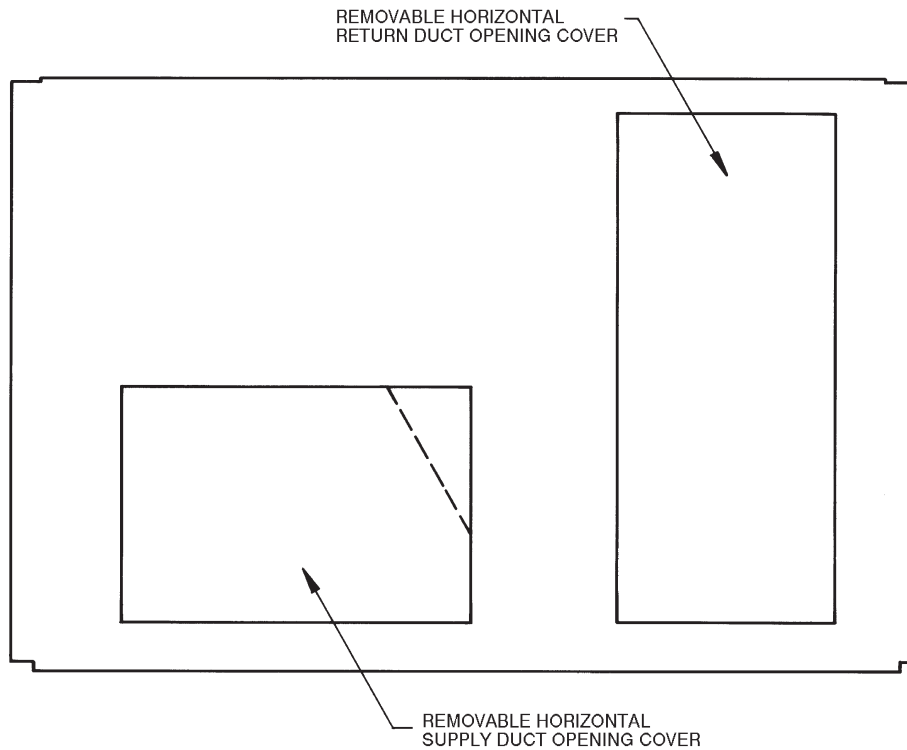


Fig. 1 - Horizontal Conversion Panels

C06108

**Step 1 — Provide Unit Support**

**Roof Curb**

Assemble or install accessory roof curb in accordance with instructions shipped with the curb. (See Fig. 2.) Install insulation, cant strips, roofing felt, and counter flashing as shown. *Ductwork must be attached to curb and not to the unit.* If electric or control power is to be routed through the basepan, attach the accessory thru-the-bottom service connections to the basepan in accordance with the accessory’s installation instructions. *These connections must be installed before the unit is set on roof curb.*

**IMPORTANT:** The gasketing between the unit and the roof curb is critical for a watertight seal. Install gasket supplied with the roof curb as shown in Fig. 2. Improperly applied gasket can result in air leaks and poor unit performance.

Curb should be level. This is necessary for unit drain to function properly. Unit leveling tolerances are show in Fig. 3. Refer to Accessory Roof Curb Installation Instructions for any additional information required.

**Slab Mount (Horizontal Units Only)**

Provide a level concrete slab that extends a minimum of 6 in. beyond unit cabinet. Install a gravel apron in front of condenser coil air inlet to prevent grass and foliage from obstructing airflow.

**NOTE:** Horizontal units may be installed on a roof curb if required.

**Alternate Unit Support**

When a curb or adapter cannot be used, support unit with sleepers, using curb or adapter support area. If sleepers cannot be used, support long sides of unit with a minimum of 3 equally spaced 4-in. x 4-in. pads on each side.

**Step 2 — Field Fabricate Ductwork**

For vertical discharge units, secure all ducts to roof curb and building structure. *Do not connect ductwork to unit.* For horizontal applications, field-supplied flanges should be attached to horizontal supply and return openings and all ductwork should be attached to the flanges. Insulate and weatherproof all external ductwork, joints, and roof openings with counter flashing and mastic in accordance with applicable codes.

Ducts passing through an unconditioned space must be insulated and covered with a vapor barrier.

If a plenum return is used on a vertical unit, the return should be ducted through the roof deck to comply with applicable fire codes.

A minimum clearance is not required around ductwork. Cabinet return-air static pressure (a negative condition) shall not exceed 0.35 in. wg with economizer or 0.45 in. wg without economizer.


**Step 3 — Install External Trap for Condensate Drain**

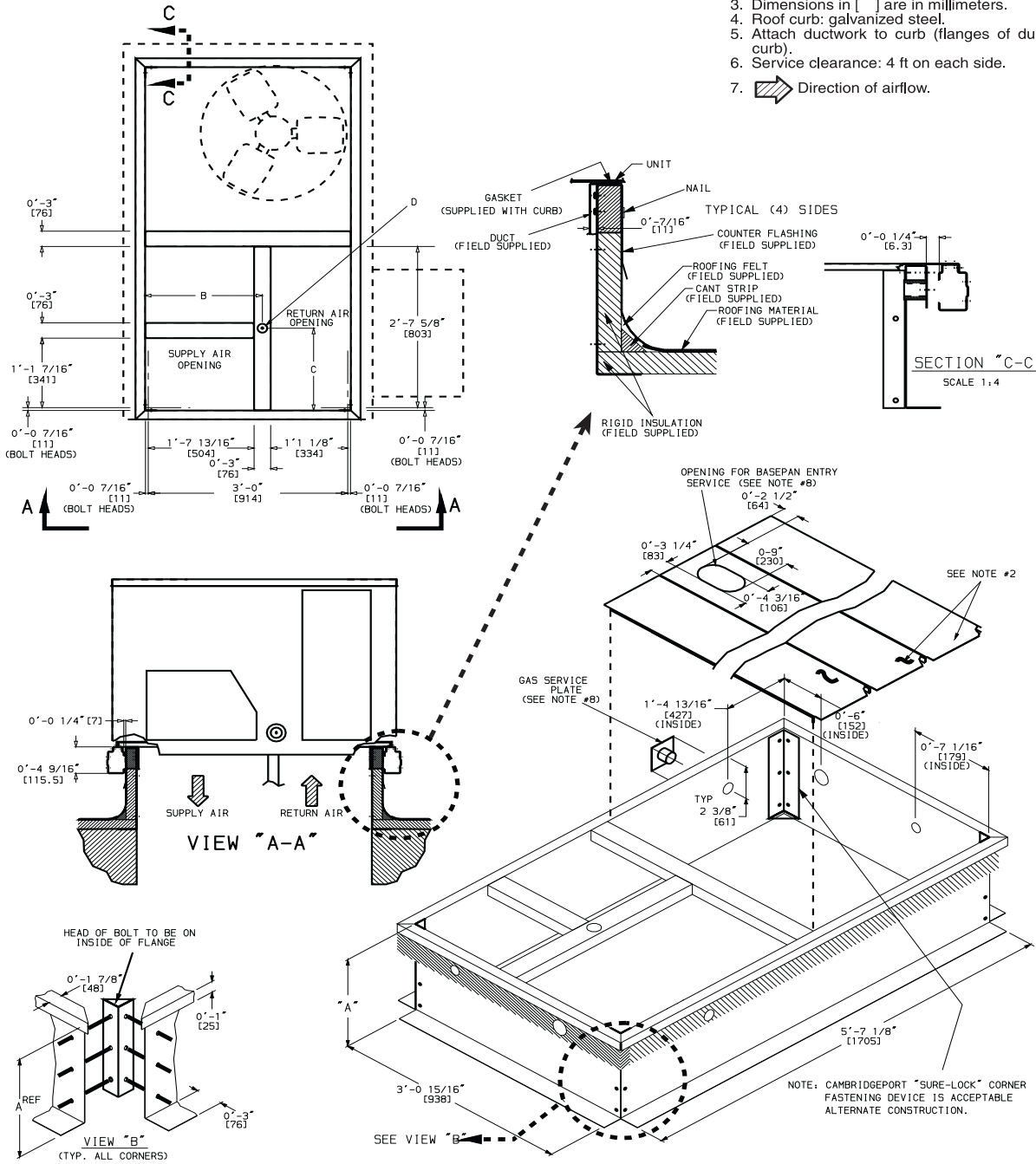
The unit has two 3/4-in. condensate drain connections, one on the bottom and the other side of the unit. Either drain connection with vertical or horizontal applications can be used. Unit discharge connections do not determine the use of drain connections.

When using the standard side drain connection, make sure the red plug in the alternate bottom connection is tight before installing the unit.

CONNECTOR PKG. ACCY.	B	C	D ALT DRAIN HOLE	GAS	POWER	CONTROL	ACCESSORY POWER
CRBTMPWR001A01	1'-9 11/16"	1'-4"	1 3/4"	3/4" NPT	3/4" NPT	1/2" NPT	1/2" NPT
CRBTMPWR003A01				1/2" NPT	3/4" NPT		

ROOF CURB ACCESSORY	A	UNIT SIZE
CRRFCURB001A01	1'-2" [356]	50TM-P06
CRRFCURB002A01	2'-0" [610]	

- NOTES:
1. Roof curb accessory is shipped disassembled.
  2. Insulated panels.
  3. Dimensions in [ ] are in millimeters.
  4. Roof curb: galvanized steel.
  5. Attach ductwork to curb (flanges of duct rest on curb).
  6. Service clearance: 4 ft on each side.
  7.  Direction of airflow.



50TM - P06

Fig. 2 - Roof Curb Details

C07047

To use the bottom drain connection for a roof curb installation, relocate the factory-installed red plug from the bottom connection to the side connection. (See Fig. 4.) The piping for the condensate drain and external trap can be completed after the unit is in place. The center drain plug looks like a square connection, however, it can be removed with a 1/2-in. socket drive extension.

All units must have an external trap for condensate drainage. Install a trap at least 4-in. deep and protect against freeze-up. If drain line is installed downstream from the external trap, pitch the line away from the unit at 1-in. per 10 ft of run. Do not use a pipe size smaller than the unit connection (3/4-in.). (See Fig. 5.)

**Step 4 — Rig and Place Unit**

Inspect unit for transportation damage. File any claim with transportation agency. Keep unit upright and do not drop. Spreader bars are not required if top crating is left on unit. Rollers may be used to move unit across a roof. Level by using unit frame as a reference. See Table 1 and Fig. 6 for additional information. Operating weight is shown in Table 1 and Fig. 7.

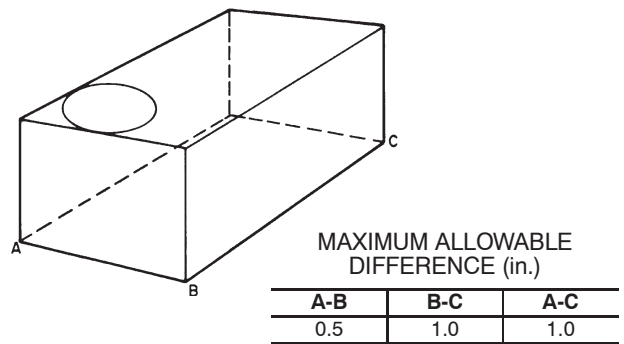
Lifting holes are provided in base rails as shown in Fig. 7. Refer to rigging instructions on unit.

**⚠ CAUTION**

**UNIT DAMAGE HAZARD**

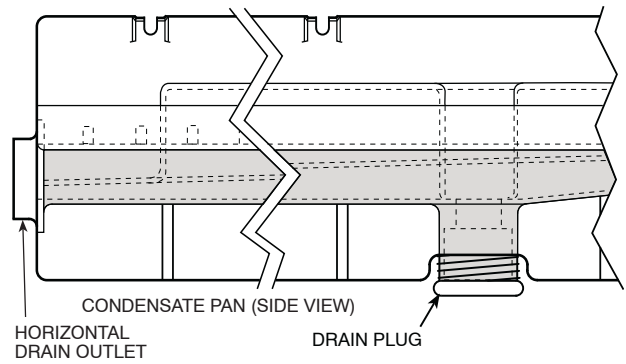
Failure to follow this caution may result in equipment damage.

All panels must be in place when rigging. Unit is not designed for handling by fork truck.



**Fig. 3 - Unit Leveling Tolerances**

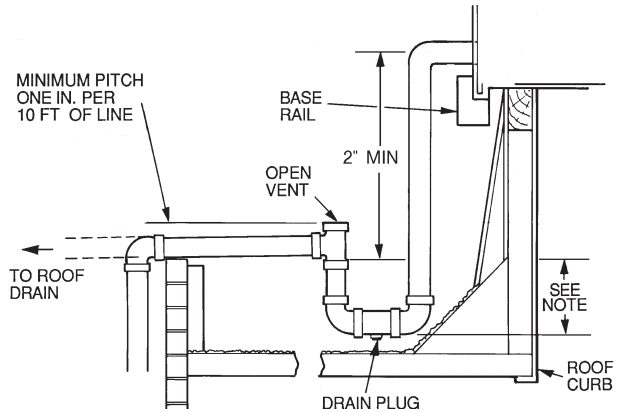
C06110



NOTE: Drain plug is shown in factory-installed position.

C06003

**Fig. 4 - Condensate Drain Pan (Side View)**



NOTE: Trap should be deep enough to offset maximum unit static difference. A 4-in. trap is recommended.

C06235

**Fig. 5 - Condensate Drain Piping Details**

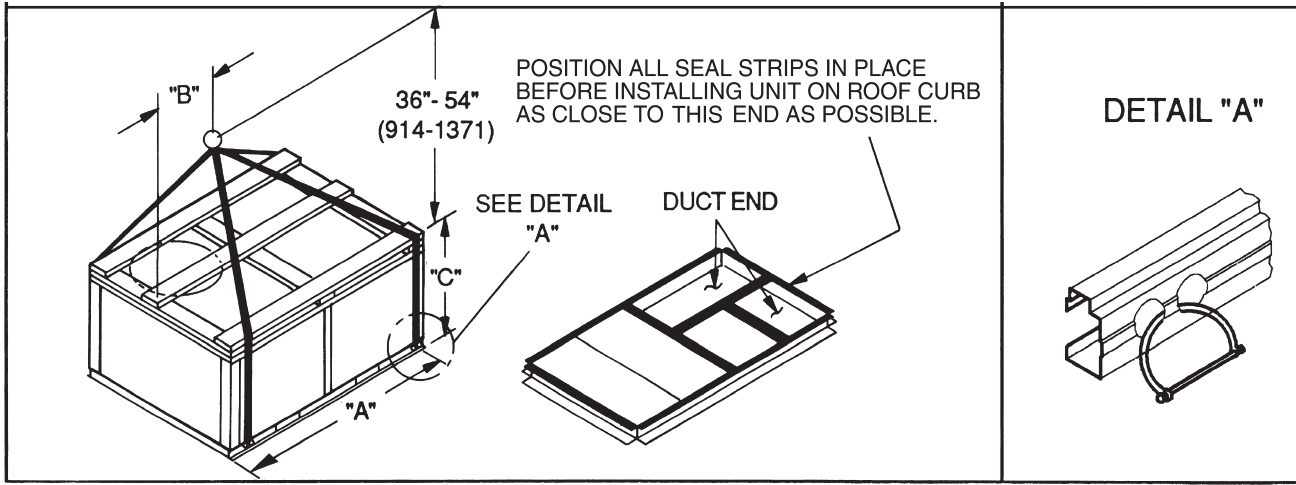
**Positioning**

Maintain clearance around and above unit to provide proper airflow and service access. (See Fig. 7). A properly positioned unit will have the following clearances: 1/4-in. clearance between roof curb and base rails on each side and duct end of unit; 1/4-in. clearance between roof curb and condenser coil end of unit. (See Fig. 2, section C-C.)

Do not install unit in an indoor location. Do not locate unit air inlets near exhaust vents or other sources of contaminated air.

Although unit is weatherproof, guard against water from higher level runoff and overhangs.

After unit is in position, remove shipping materials and top crating.



C06005

50TM – P06

**NOTES:**

1. Dimension in ( ) is in millimeters.
2. Hook rigging shackles through holes in base rail, as shown in detail "A." Holes in base rails are centered around the unit center of gravity. Use wooden top skid when rigging to prevent rigging straps from damaging unit.
3. Weights do not include economizer.

UNIT SIZE	MAX WEIGHT		DIMENSIONS					
			"A"		"B"		"C"	
	lb	kg	in.	mm	in.	mm	in.	mm
50TM-P06	515	233	73.69	1872	35.00	889	33.35	847

**Fig. 6 - Rigging Details**

**⚠ CAUTION**

**UNIT DAMAGE HAZARD**

Failure to follow this caution may result in equipment damage.

All panels must be in place when rigging. Unit is not designed for handling by fork truck.

UNIT	STD. UNIT WEIGHT		ECON. IV WEIGHT		ECON. IV WEIGHT		CORNER WEIGHT		CORNER WEIGHT		CORNER WEIGHT					
	LBS.	KG.	LBS.	KG.	LBS.	KG.	LBS.	KG.	LBS.	KG.	LBS.	KG.				
50TM-P06	485	211	50	22.7	90	40.9	133	60.3	113	51.3	101	45.8	118	53.5	2'-9 5/16	846.5

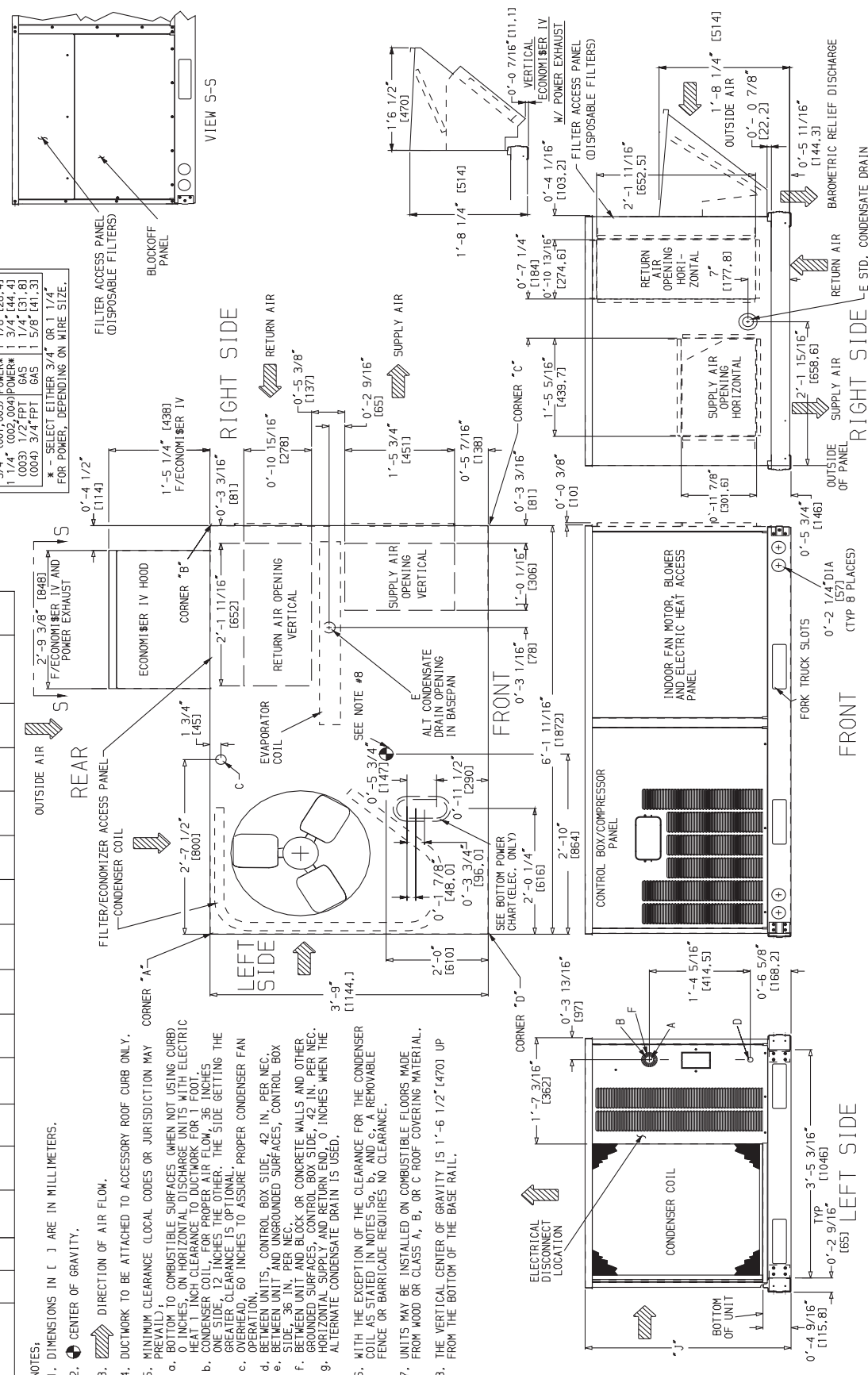
CONNECTION SIZES

A	1 3/8" DIA.	ESSI FIELD POWER SUPPLY HOLE
B	2" DIA.	ESTI POWER SUPPLY KNOCK-OUT
C	1 3/4" DIA.	[44] CHARGING PORT HOLE
D	7/8" DIA.	[22] FIELD CONTROL WIRING HOLE
E	3/4"-14 NPT	CONDENSATE DRAIN
F	2 1/2" DIA.	[64] POWER SUPPLY KNOCK-OUT

BOTTOM POWER CHART. THESE NECESSARY PACKAGES -

THREADED CONDUIT SIZE	WIRE USE	REG'D HOLE SIZES (MAX.)
1/2"	ACC.	7/8" [22.2]
3/4"	2AV	7/8" [22.2]
1 1/4"	POWER*	1 1/8" [28.4]
1 1/2"	POWER*	1 3/4" [44.4]
2"	POWER*	1 3/4" [44.4]
2 1/2"	POWER*	1 3/4" [44.4]
3"	POWER*	1 3/4" [44.4]
3 1/2"	POWER*	1 3/4" [44.4]
4"	POWER*	1 3/4" [44.4]

\* - SELECT EITHER 3/4" OR 1 1/4" FOR POWER, DEPENDING ON WIRE SIZE.



- NOTES:
1. DIMENSIONS IN ( ) ARE IN MILLIMETERS.
  2. ⦿ CENTER OF GRAVITY.
  3. ⦿ DIRECTION OF AIR FLOW.
  4. DUCTWORK TO BE ATTACHED TO ACCESSORY ROOF CURB ONLY.
  5. MINIMUM CLEARANCE (LOCAL CODES OR JURISDICTION MAY PREVAIL):
    - a. BOTTOM TO COMBUSTIBLE SURFACES (WHEN NOT USING CURB) 0 INCHES, ON HORIZONTAL DISCHARGE UNITS WITH ELECTRIC HEAT 1 INCH CLEARANCE TO DUCTWORK FOR 1 FOOT.
    - b. CONDENSER COIL, FOR PROPER AIR FLOW, 36 INCHES ONE SIDE, 12 INCHES THE OTHER. THE SIDE GETTING THE GREATER CLEARANCE IS OPTIONAL.
    - c. OVERHEAD, 60 INCHES TO ASSURE PROPER CONDENSER FAN OPERATION.
    - d. BETWEEN UNITS, CONTROL BOX SIDE, 42 IN. PER NEC. BETWEEN UNITS, PER UNGROUND SURFACES, CONTROL BOX SIDE, 36 IN. PER NEC.
    - e. BETWEEN UNIT AND BLOCK OR CONCRETE WALLS AND OTHER GROUNDED SURFACES, CONTROL BOX SIDE, 42 IN. PER NEC.
    - f. GROUNDED SURFACES, CONTROL BOX SIDE, 42 IN. PER NEC.
    - g. HORIZONTAL SUPPLY AND RETURN END, 0 INCHES WHEN THE ALTERNATE CONDENSATE DRAIN IS USED.
  6. WITH THE EXCEPTION OF THE CLEARANCE FOR THE CONDENSER COIL AS STATED IN NOTES 5g, b, AND c, A REMOVABLE FENCE OR BARRICADE REQUIRES NO CLEARANCE.
  7. UNITS MAY BE INSTALLED ON COMBUSTIBLE FLOORS MADE FROM WOOD OR CLASS A, B, OR C ROOF COVERING MATERIAL.
  8. THE VERTICAL CENTER OF GRAVITY IS 1'-6 1/2" [470] UP FROM THE BOTTOM OF THE BASE RAIL.

Fig. 7 - Base Unit Dimensions

**Table 1 – Physical Data**

<b>50TM-P UNIT SIZE</b>		<b>006</b>
<b>NOMINAL CAPACITY (Tons)</b>		5
<b>OPERATING WEIGHT (lb)</b>		
Unit		
Al/Al*		465
EconoMi\$er IV		50
Roof Curb (14-in.)		115
<b>COMPRESSOR</b>		Scroll
Quantity		1
Oil		42
<b>REFRIGERANT TYPE</b>		R-410A (Puron® Refrigerant)
Operating Charge (lb-oz)		
Circuit 1		7-14
Circuit 2		-
<b>CONDENSER COIL</b>		Enhanced Aluminum Tubes, Aluminum Fins,
Rows...Fins/in.		2...17
Total Face Area (sq ft)		10.42
<b>CONDENSER FAN</b>		Propeller Type
Nominal Cfm		4,000
Quantity...Diameter (in.)		1...22.0
Motor Hp...Rpm		1/4...1100
Watts Input (Total)		325
<b>EVAPORATOR COIL</b>		Enhanced Copper Tubes, Aluminum Double-Wavy Fins, Face Split
Expansion Device		Acutrol™ Metering Device
Rows...Fins/in.		3...15
Total Face Area (sq ft)		5.5
<b>EVAPORATOR FAN</b>		Centrifugal Type
Quantity...Size (in.)	Std	1...10 x 10
	High-Static	1...10 x 10
Type Drive	Std	Belt
	High-Static	Belt
Nominal Cfm		2000
Maximum Continuous Bh	Std	2.40
	High-Static	2.90
Motor Frame Size	Std	56
	Hlgh-Static	56
Nominal Rpm High/Low	Std	1725
	Hlgh-Static	1725
Fan Rpm Range	Std	875-1192
	High-Static	1300-1685
Motor Bearing Type		Ball
Maximum Allowable Rpm		2100
Motor Pulley Pitch Diameter Min/Max(in.)	Std	2.8/3.8
	High-Static	3.4/4.4
Nominal Motor Shaft Diameter (in.)	Std	5/8
	High-Static	7/8
Fan Pulley Pitch Diameter (in.)	Std	5.5
	High-Static	4.5
Belt, Quantity...Type...Length (in.)	Std	1...A...40
	High-Static	1...A...40
Pulley Center Line Distance Min. (in.)	Std	14.7-15.5
	High-Static	14.7-15.5
Speed Change per Full Turn of	Std	65
Moveable Pulley Flange (rpm)	High-Static	75
Moveable Pulley Maximum Full Turns	Std	5
From Closed Position	High-Static	5
Factory Setting (rpm)	Std	3
	High-Static	3-1/2
Factory Speed Setting (rpm)	Std	1003
	High-Static	1454
Fan Shaft Diameter at Pulley (in.)		5/8
<b>HIGH-PRESSURE SWITCH (psig)</b>		
Standard Compressor Internal Relief (Differential)		550-625
Cutout		630±10
Reset (Auto.)		505±20
<b>LOSS-OF-CHARGE (LOW PRESURE) SWITCH (psig)</b>		
Cutout		27±3
Reset (Auto.)		44±5
<b>FREEZE-PROTECTION THERMOSTAT (F)</b>		
Opens		30±5
Closes		45±5
<b>OUTDOOR-AIR INLET SCREENS</b>		Cleanable. Screen size and quantity varies with option selected.
<b>RETURN-AIR FILTERS</b>		Throwaway
Quantity...Size (in.)		2...16 x 25 x 2

**LEGEND**

- Al** – Aluminum
- Bh** – Brake Horsepower
- Cu** – Copper

\*Evaporator coil fin material/condenser coil fin material. Contact your local Carrier representative for details about coated fins.

**50TM – P06**

## Step 5 — Make Electrical Connections

### **⚠ WARNING**

#### **ELECTRICAL SHOCK HAZARD**

Failure to follow this warning could result in personal injury or death.

Unit cabinet must have an uninterrupted, unbroken electrical ground to minimize the possibility of personal injury if an electrical fault should occur. This ground may consist of electrical wire connected to unit ground lug in control compartment, or conduit approved for electrical ground when installed in accordance with NEC (National Electrical Code); ANSI/NFPA (American National Standards Institute/National Fire Protection Association), latest edition (in Canada, Canadian Electrical Code CSA [Canadian Standards Association] C22.1), and local electrical codes.

### **Field Power Supply**

All units except 208/230-v units are factory wired for the voltage shown on the nameplate. The 208/230v unit comes factory wired for 230v applications. If the 208/230-v unit is to be connected to a 208-v power supply, the transformer must be rewired by moving the black wire from 230-v 1/4-in. spade terminal and connecting it to 200-v 1/4-in. spade terminal of transformer. (See Table 9.)

Refer to unit label diagram for additional information. Pigtails are provided for field wire connections. Use factory-supplied splices or UL (Underwriters' Laboratories) approved copper/aluminum connector.

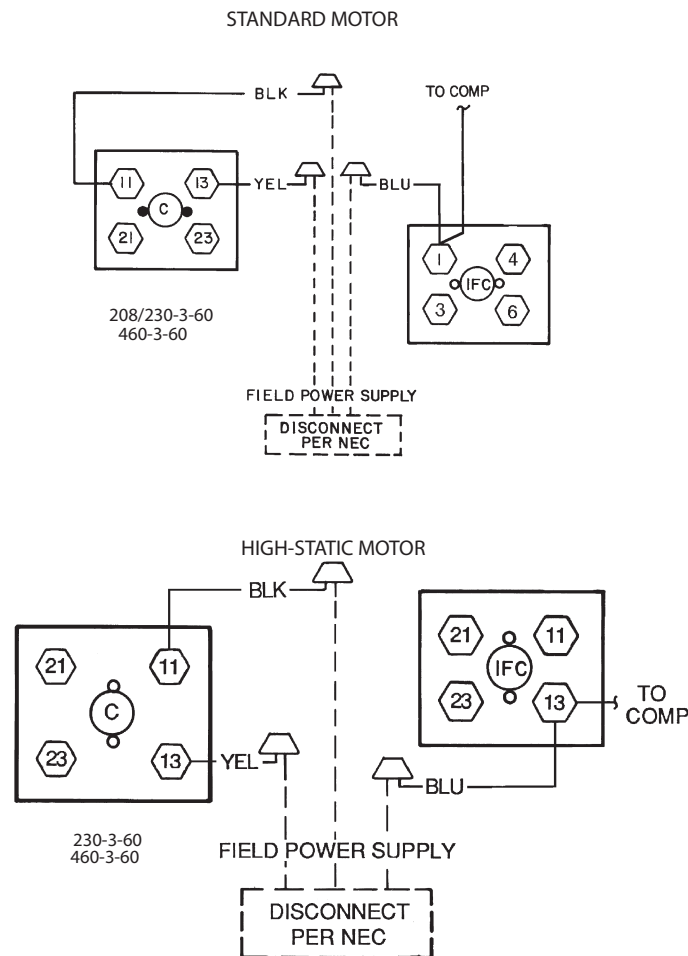
When installing units, provide a disconnect per NEC.

All field wiring must comply with the NEC and local requirements.

Install field wiring as follows:

1. Install conduit through side panel openings. For units without electric heat, install conduit between disconnect and control box.
2. Install power lines to terminal connections as shown in Fig. 8.

Power wiring leads are located inside power wiring access panel.



#### LEGEND

<b>C</b>	- Contactor
<b>COMP</b>	- Compressor
<b>IFC</b>	- Indoor (Evaporator) Fan Contactor
<b>NEC</b>	- National Electric Code
<b>TB</b>	- Terminal Block

**Fig. 8 - Power Wiring Connections**

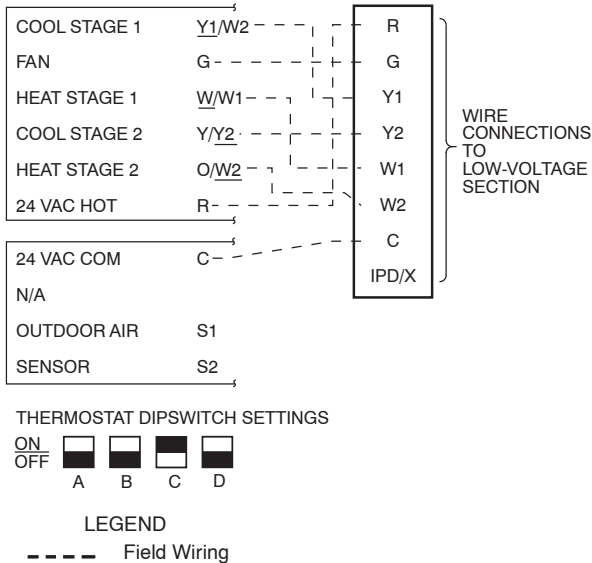
C07053



## Field Control Wiring

Install a Carrier-approved accessory thermostat. Install thermostat assembly according to the installation instructions included with accessory. Locate thermostat assembly on a solid wall in the conditioned space to sense average temperature in accordance with thermostat installation instructions. Connect thermostat wires to terminal board.

Route thermostat cable or equivalent single leads of colored wire from subbase terminals to low-voltage connections on unit. (See Fig. 9.)



NOTE: Underlined letter indicates active thermostat output when configured for A/C operation.

C06008

Fig. 9 - Low-Voltage Connections

**NOTE:** For wire runs up to 50 ft, use no. 18 AWG (American Wire Gauge) insulated wire (35°C minimum). For 50 to 75 ft, use no. 16 AWG insulated wire (35°C minimum). For over 75 ft, use no. 14 AWG insulated wire (35°C minimum). All wire larger than no. 18 AWG cannot be directly connected to the thermostat and will require a junction box and splice at the thermostat.

Pass the control wires through the hole provided in the corner post; then feed wires through the raceway built into the corner post to the 24-v barrier located on the left side of the control box. (See Fig. 10.) The raceway provides the UL required clearance between high- and low-voltage wiring.

**NOTE:** If thru-the-bottom power connections are used, refer to the accessory installation instructions for information on power wiring.

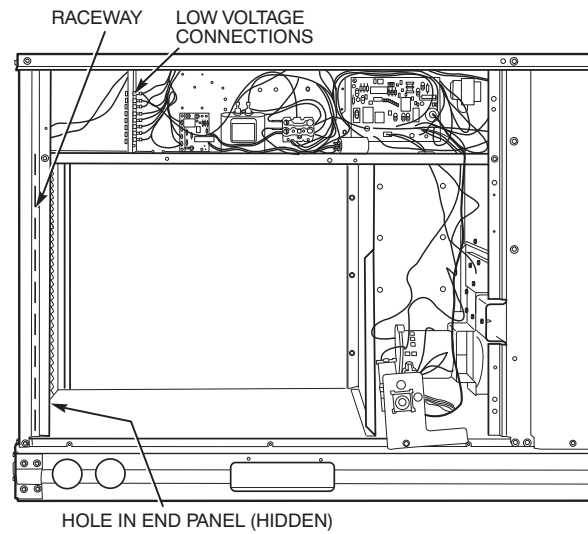


Fig. 10 - Field Control Wiring Raceway

C07054

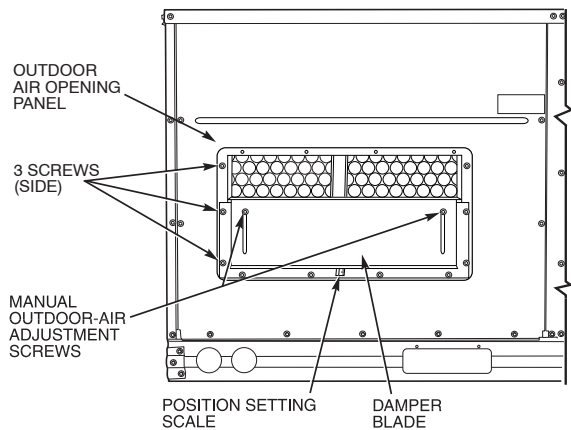
## Step 6 — Adjust Factory-Installed Options

### Manual Outdoor-Air Damper

The outdoor-air hood and screen are attached to the basepan at the bottom of the unit for shipping.

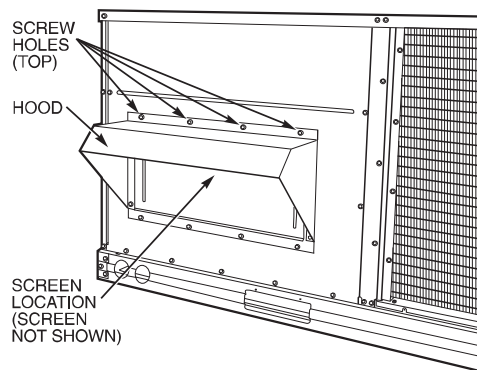
#### Assembly:

1. Determine quantity of ventilation required for building. Record amount for use in Step 8.
2. Remove and save outdoor-air opening panel and screws. (See Fig. 11.)
3. Separate hood and screen from basepan by removing the 4 screws securing them. Save all screws.
4. Replace outdoor-air opening panel.
5. Place hood on front of outdoor-air opening panel. See Fig. 12 for hood details. Secure top of hood with the 4 screws removed in Step 3. (See Fig. 13.)
6. Remove and save 6 screws (3 on each side) from sides of the manual outdoor-air damper assembly.
7. Align screw holes on hood with screw holes on side of manual outdoor-air damper assembly. (See Fig. 12 and 13.) Secure hood with 6 screws from Step 6.
8. Adjust minimum position setting of the damper blade by adjusting the manual outdoor-air adjustment screws on the front of the damper blade. (See Fig. 11.) Slide blade vertically until it is in the appropriate position determined by Fig. 14. Tighten screws.
9. Remove and save screws currently on sides of hood. Insert screen. Secure screen to hood using the screws. (See Fig. 13.)



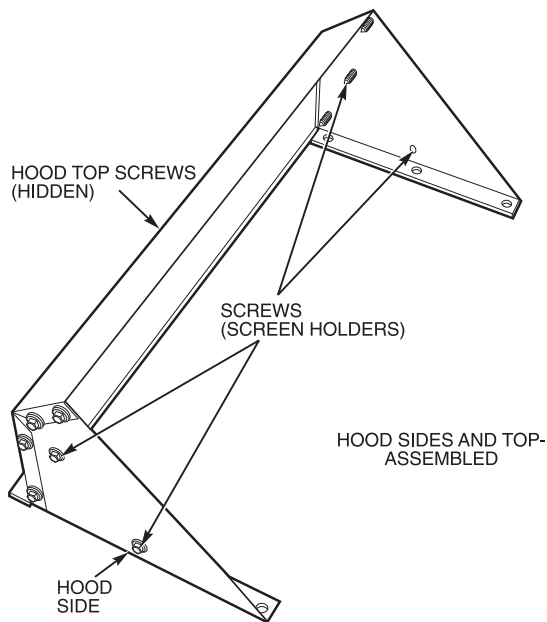
**Fig. 11 - Damper Panel with Manual Outdoor-Air Damper Installed**

C06130



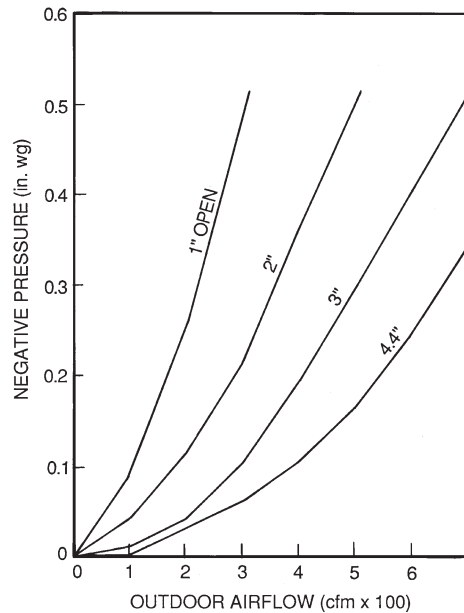
**Fig. 13 - Outdoor-Air Damper with Hood Attached**

C06131



**Fig. 12 - Outdoor-Air Hood Details**

C06013



**Fig. 14 - Outdoor-Air Damper Position Setting**

C07057

**Convenience Outlet**

An optional convenience outlet provides power for rooftop use. For maintenance personnel safety, the convenience outlet power is off when the unit disconnect is off. Adjacent unit outlets may be used for service tools. An optional "Hot Outlet" is available from the factory as a special order item.

**Novar Controls**

Optional Novar controls (ETM 3051) are available for replacement or new construction jobs.

**PremierLink™ Control**

The PremierLink controller is compatible with Carrier Comfort Network® (CCN) devices. This control is designed to allow users the access and ability to change factory-defined settings, thus expanding the function of the standard unit control board. Carrier's diagnostic standard tier display tools such as Navigator™ or Scrolling Marquee can be used with the PremierLink controller. The PremierLink controller (see Fig. 15 and 16) requires the use of a Carrier electronic thermostat or a CCN connection for time broadcast to initiate its internal timeclock. This is necessary for broadcast of time of day functions (occupied/unoccupied). No sensors are supplied with the field-mounted PremierLink control. The factory-installed PremierLink control includes only the supply-air temperature (SAT) sensor and the outdoor air temperature (OAT) sensor as standard. An indoor air quality (CO2) sensor can be added as an option. Refer to Table 2 for sensor usage. Refer to Fig. 17 for PremierLink controller wiring. The PremierLink control may be mounted in the control panel or an area below the control panel.

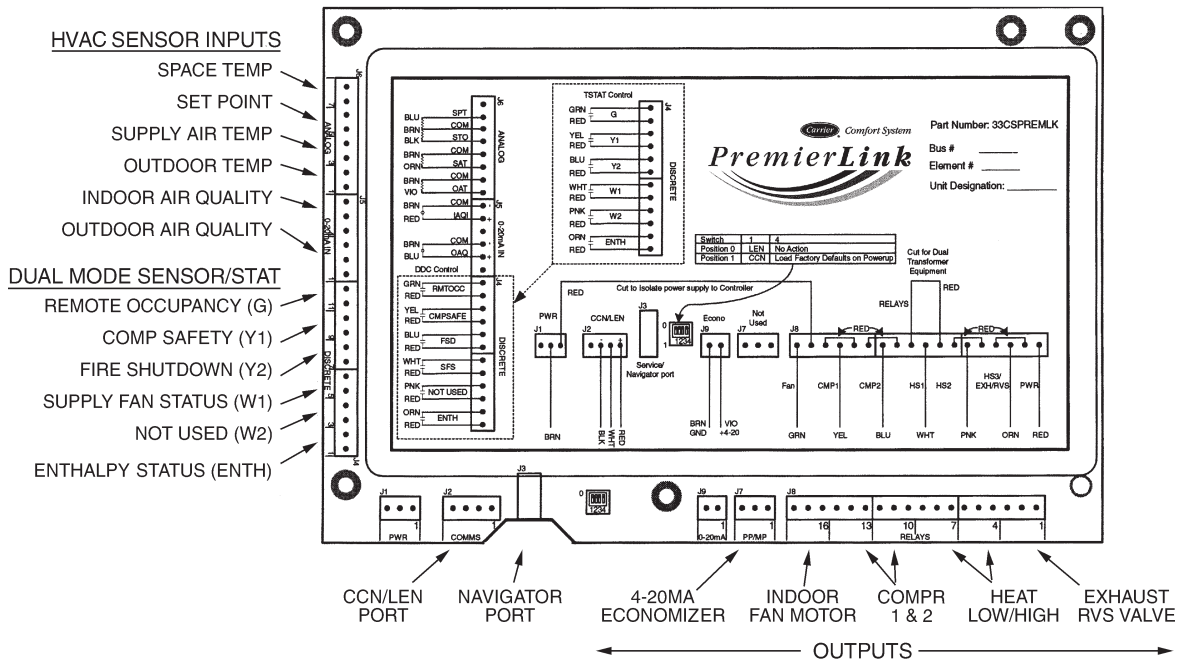


Fig. 15 - PremierLink™ Controller

C06016

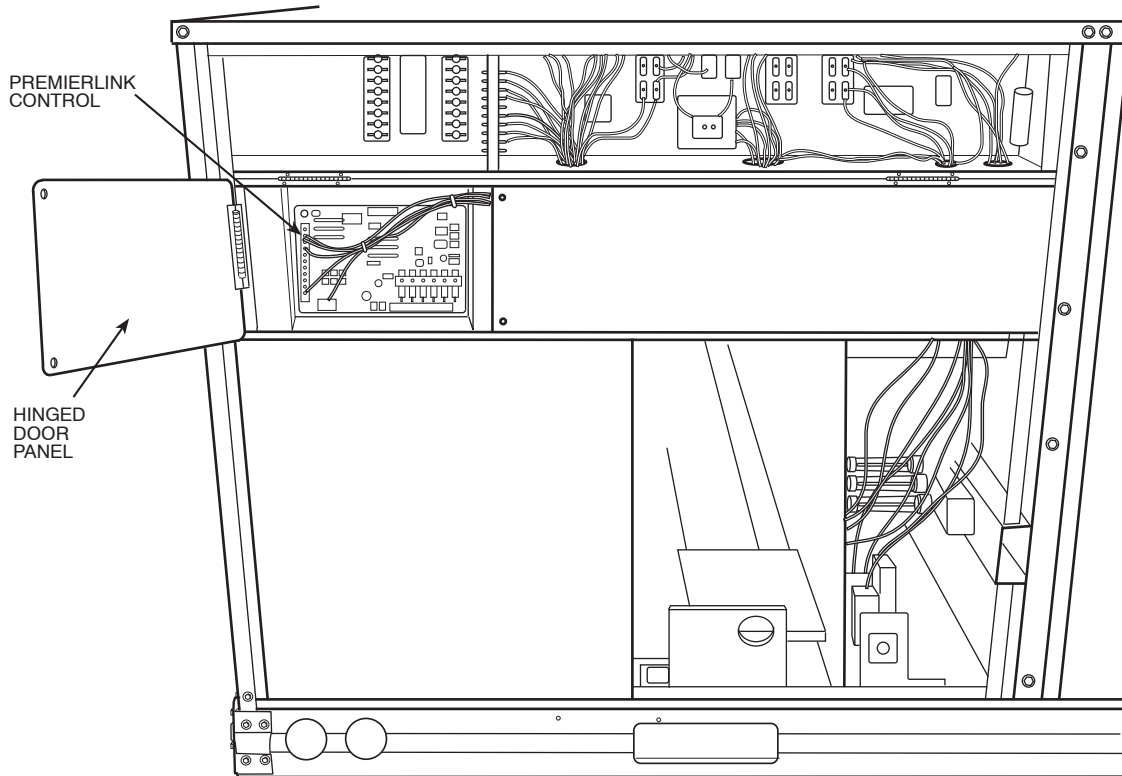


Fig. 16 - PremierLink Controller (Installed)

C06017

**NOTE:** PremierLink controller versions 1.3 and later are shipped in Sensor mode. If used with a thermostat, the PremierLink controller must be configured to Thermostat mode.

**Install the Supply Air Temperature (SAT) Sensor**

When the unit is supplied with a factory-mounted PremierLink control, the supply-air temperature (SAT) sensor (33ZCSENSAT) is factory-supplied and wired. The wiring is routed from the PremierLink control over the control box, through a grommet, into

the fan section, down along the back side of the fan, and along the fan deck over to the supply-air opening.

The SAT probe is wire-tied to the supply-air opening (on the horizontal opening end) in its shipping position. Remove the sensor for installation. Re-position the sensor in the flange of the supply-air opening or in the supply air duct (as required by local codes). Drill or punch a 1/2-in. hole in the flange or duct. Use two field-supplied, self-drilling screws to secure the sensor probe in a horizontal orientation.

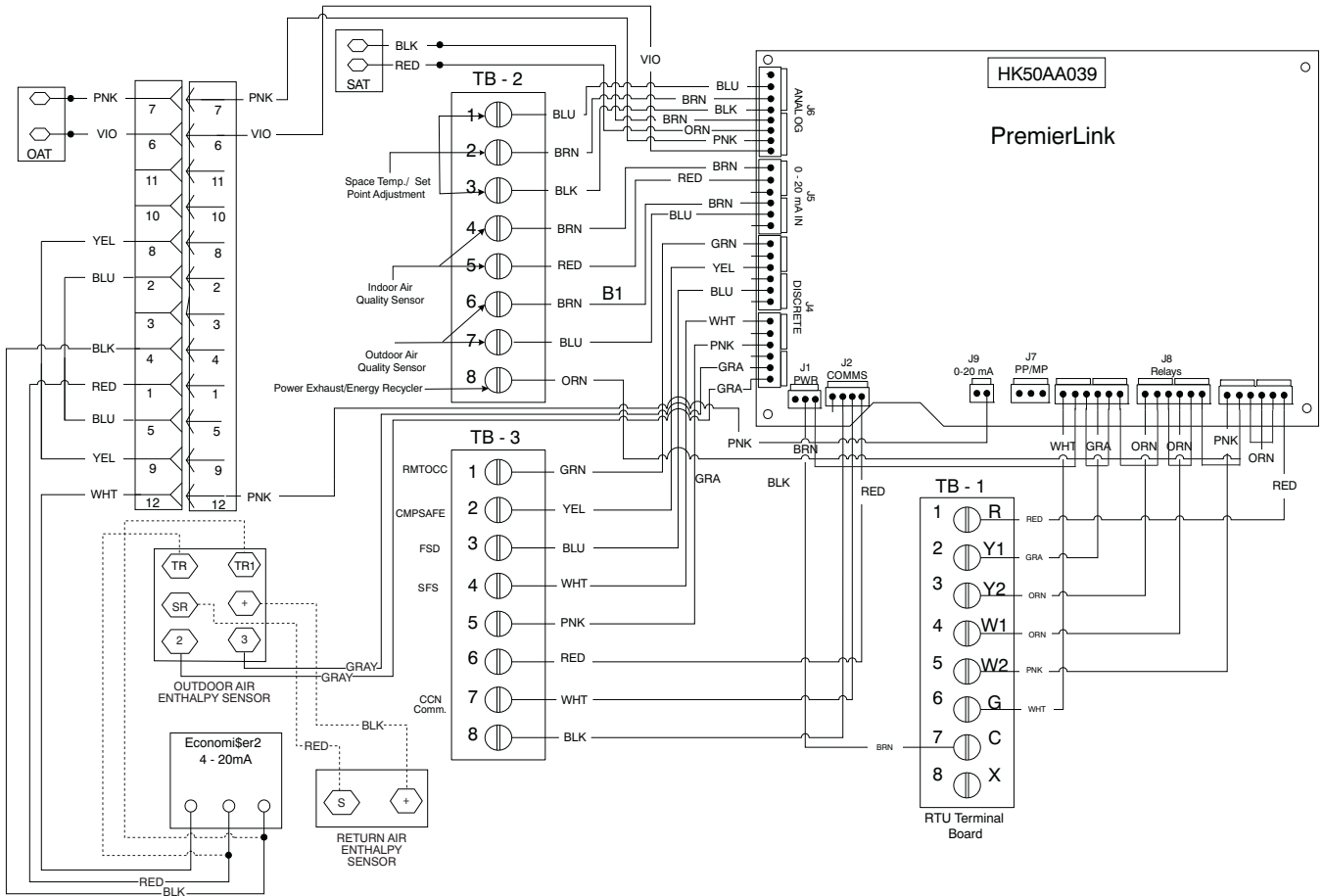


Fig. 17 - Typical PremierLink™ Controls Wiring

C07073

**NOTE:** The sensor must be mounted in the discharge airstream downstream of the cooling coil and any heating devices. Be sure the probe tip does not come in contact with any of the unit or heat surfaces.

**Outdoor Air Temperature (OAT) Sensor**

When the unit is supplied with a factory-mounted PremierLink control, the outdoor-air temperature sensor (OAT) is factory-supplied and wired.

**Install the Indoor Air Quality (CO<sub>2</sub>) Sensor**

Mount the optional indoor air quality (CO<sub>2</sub>) sensor according to manufacturer specifications.

A separate field-supplied transformer must be used to power the CO<sub>2</sub> sensor.

Wire the CO<sub>2</sub> sensor to the COM and IAQI terminals of J5 on the PremierLink controller. Refer to the PremierLink Installation, Start-up, and Configuration Instructions for detailed wiring and configuration information.

**Enthalpy Sensors and Control**

The enthalpy control (HH57AC077) is supplied as a field-installed accessory to be used with the economizer damper control option. The outdoor air enthalpy sensor is part of the enthalpy control. The separate field-installed accessory return air enthalpy sensor (HH57AC078) is required for differential enthalpy control.

**NOTE:** The enthalpy control must be set to the “D” setting for differential enthalpy control to work properly.

The enthalpy control receives the indoor and return enthalpy from the outdoor and return air enthalpy sensors and provides a dry contact switch input to the PremierLink controller. Locate the controller in place of an existing economizer controller or near the actuator. The mounting plate may not be needed if existing bracket is used.

A closed contact indicates that outside air is preferred to the return air. An open contact indicates that the economizer should remain at minimum position.

**Outdoor Air Enthalpy Sensor/Enthalpy Controller (HH57AC077)**

To wire the outdoor air enthalpy sensor, perform the following (See Fig. 18 and 19):

**NOTE:** The outdoor air sensor can be removed from the back of the enthalpy controller and mounted remotely.

1. Use a 4-conductor, 18 or 20 AWG cable to connect the enthalpy control to the PremierLink controller and power transformer.
2. Connect the following 4 wires from the wire harness located in rooftop unit to the enthalpy controller:
  - a. Connect the BRN wire to the 24 vac terminal (TR1) on enthalpy control and to pin 1 on 12-pin harness.
  - b. Connect the RED wire to the 24 vac GND terminal (TR) on enthalpy sensor and to pin 4 on 12-pin harness.
  - c. Connect the GRAY/ORN wire to J4-2 on Premier Link controller and to terminal (3) on enthalpy sensor.
  - d. Connect the GRAY/RED wire to J4-1 on Premier Link controller and to terminal (2) on enthalpy sensor.

Table 2 – PremierLink™ Sensor Usage

APPLICATION	OUTDOOR AIR TEMPERATURE SENSOR	RETURN AIR TEMPERATURE SENSOR	OUTDOOR AIR ENTHALPY SENSOR	RETURN AIR ENTHALPY SENSOR
Dry Bulb Temperature with PremierLink* (PremierLink requires 4-20 mA Actuator)	Included – HH79NZ017	—	—	—
Differential Dry Bulb Temperature with PremierLink* (PremierLink requires 4-20 mA Actuator)	Included – HH79NZ017	Required – 33ZCT55SPT or Equivalent	—	—
Single Enthalpy with PremierLink* (PremierLink requires 4-20 mA Actuator)	Included – Not Used	—	Required – HH57AC077	—
Differential Enthalpy with PremierLink* (PremierLink requires 4-20 mA Actuator)	Included – Not Used	—	Required – HH57AC077	Required – HH57AC078

50TM – P06

\*PremierLink control requires Supply Air Temperature sensor 33ZCSENSAT and Outdoor Air Temperature sensor HH79NZ017

— Included with factory-installed PremierLink control; field-supplied and field-installed with field-installed PremierLink control.

NOTES:

- CO<sub>2</sub> Sensors (Optional):  
 33ZCSENSCO2 — Room sensor (adjustable). Aspirator box is required for duct mounting of the sensor.  
 33ZCASPCO2 — Aspirator box used for duct-mounted CO<sub>2</sub> room sensor.  
 33ZCT55CO2 — Space temperature and CO<sub>2</sub> room sensor with override.  
 33ZCT56CO2 — Space temperature and CO<sub>2</sub> room sensor with override and set point.

2. All units include the following Standard Sensors:

Outdoor-Air Sensor — 50HJ540569 — Opens at 67°F, closes at 52°F, not adjustable.

Mixed-Air Sensor — HH97AZ001 — (PremierLink control requires Supply Air Temperature sensor 33ZCSENSAT and Outdoor Air Temperature Sensor HH79NZ017)

Compressor Lockout Sensor — 50HJ540570 — Opens at 35°F, closes at 50°F.

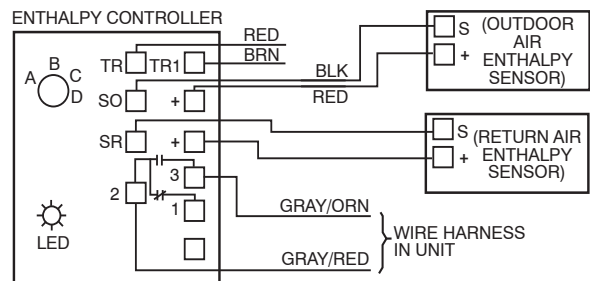
**NOTE:** If installing in a Carrier rooftop, use the two gray wires provided from the control section to the economizer to connect PremierLink controller to terminals 2 and 3 on enthalpy sensor.

**Return Air Enthalpy Sensor**

Mount the return-air enthalpy sensor (HH57AC078) in the return-air duct. The return air sensor is wired to the enthalpy controller (HH57AC077). The outdoor enthalpy changeover set point is set at the controller.

To wire the return air enthalpy sensor, perform the following (see Fig. 18):

- Use a 2-conductor, 18 or 20 AWG, twisted pair cable to connect the return air enthalpy sensor to the enthalpy controller.
- At the enthalpy control remove the factory-installed resistor from the (SR) and (+) terminals.
- Connect the field-supplied RED wire to (+) spade connector on the return air enthalpy sensor and the (SR+) terminal on the enthalpy controller. Connect the BLK wire to (S) spade connector on the return air enthalpy sensor and the (SR) terminal on the enthalpy controller.

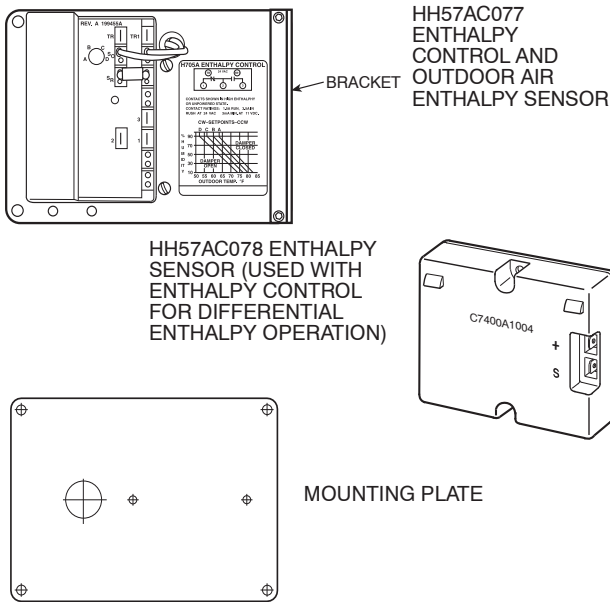


NOTES:

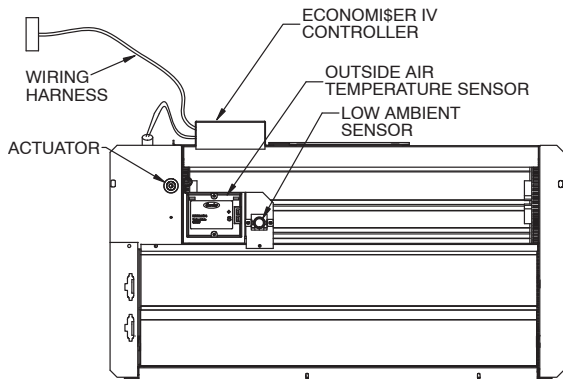
- Remove factory-installed jumper across SR and + before connecting wires from return air sensor.
- Switches shown in high outdoor air enthalpy state. Terminals 2 and 3 close on low outdoor air enthalpy relative to indoor air enthalpy.
- Remove sensor mounted on back of control and locate in outside air-stream.

C06019

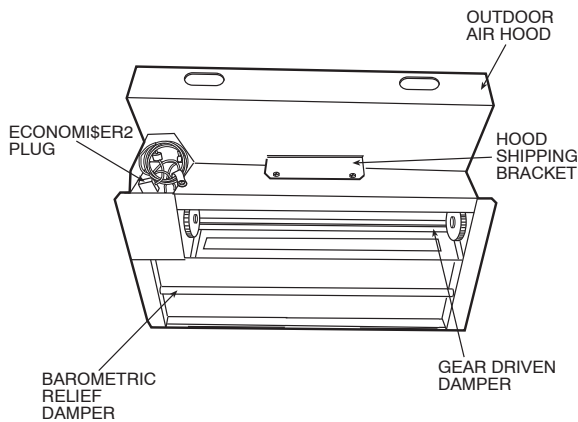
Fig. 18 - Outdoor and Return Air Sensor Wiring Connections for Differential Enthalpy Control



**Fig. 19 - Differential Enthalpy Control, Sensor and Mounting Plate (33AMKITENT006)**



**Fig. 20 - EconoMiSer IV Component Locations**



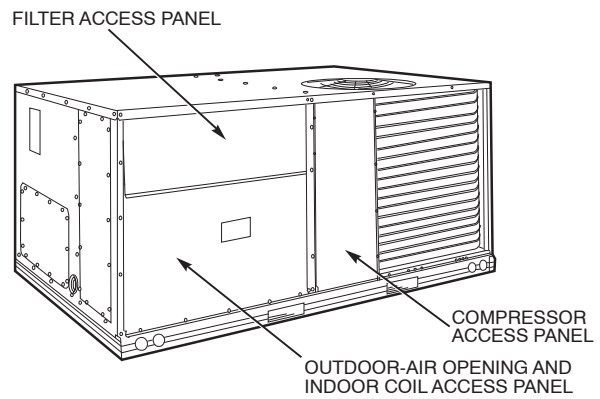
**Fig. 21 - EconMiSer2 Component Locations**

**Optional EconoMiSerIV and EconoMiSer2**

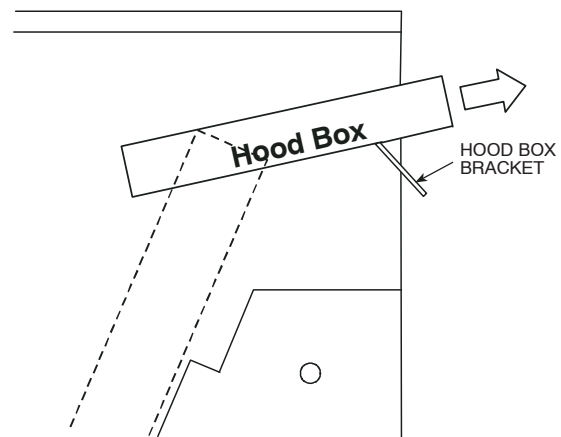
See Fig. 20 for EconoMiSer IV component locations. See Fig. 21 for EconoMiSer2 component locations.

**NOTE:** These instructions are for installing the optional EconoMiSer IV and EconoMiSer2 only. Refer to the accessory EconoMiSer IV or EconoMiSer2 installation instructions when field installing an EconoMiSer IV or EconoMiSer2 accessory.

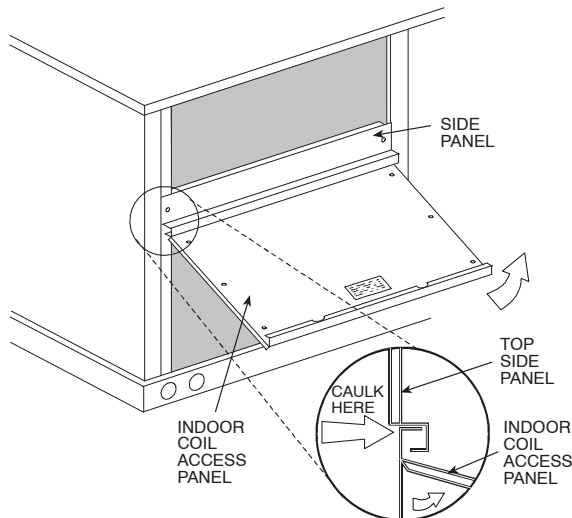
1. To remove the existing unit filter access panel, raise the panel and swing the bottom outward. The panel is now disengaged from the track and can be removed. (See Fig. 22.)
2. The box with the economizer hood components is shipped in the compartment behind the economizer. The EconoMiSer IV controller is mounted on top of the EconoMiSer IV in the position shown in Fig. 20. The optional EconoMiSer2 with 4 to 20 mA actuator signal control does not include the EconoMiSer IV controller. To remove the component box from its shipping position, remove the screw holding the hood box bracket to the top of the economizer. Slide the hood box out of the unit. (See Fig. 23.)



**Fig. 22 - Typical Access Panel Locations**

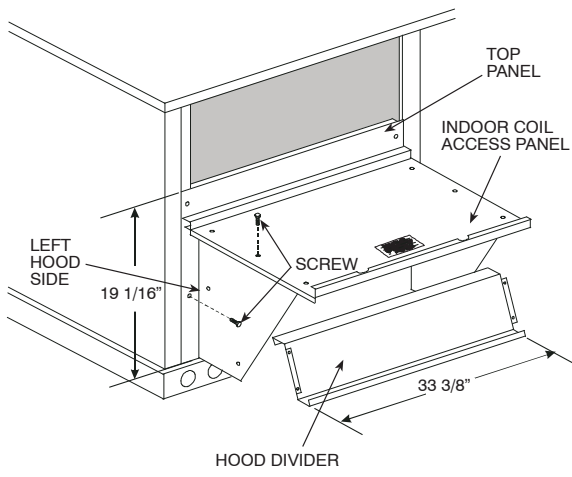


**Fig. 23 - Hood Box Removal**



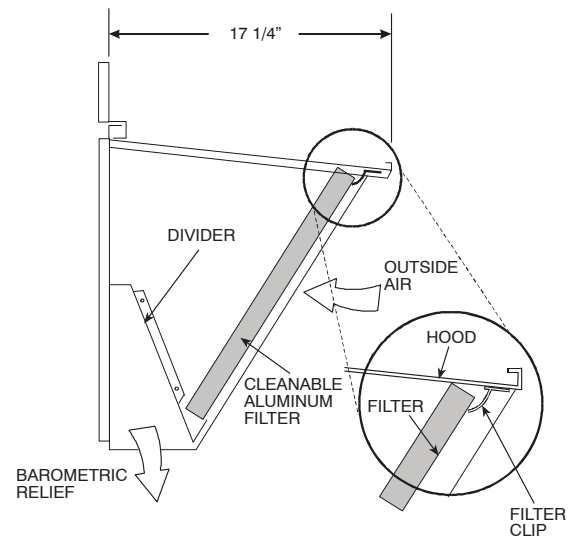
C06025

**Fig. 24 - Indoor Coil Access Panel Relocation**



C06026

**Fig. 25 - Outdoor-Air Hood Construction**



C06027

**Fig. 26 - Filter Installation**

3. The indoor coil access panel will be used as the top of the hood. Remove the screws along the sides and bottom of the indoor coil access panel. (See Fig. 24.)
4. Swing out indoor coil access panel and insert the hood sides under the panel (hood top). Use the screws provided to attach the hood sides to the hood top. Use screws provided to attach the hood sides to the unit. (See Fig. 25.)
5. Remove the shipping tape holding the economizer barometric relief damper in place.
6. Insert the hood divider between the hood sides. (See Fig. 25 and 26.) Secure hood divider with 2 screws on each hood side. The hood divider is also used as the bottom filter rack for the aluminum filter.
7. Open the filter clips which are located underneath the hood top. Insert the aluminum filter into the bottom filter rack (hood divider). Push the filter into position past the open filter clips. Close the filter clips to lock the filter into place. (See Fig. 26.)
8. Caulk the ends of the joint between the unit top panel and the hood top. (See Fig. 24.)
9. Replace the filter access panel.
10. Install all EconoMi\$er IV accessories. EconoMi\$er IV wiring is shown in Fig. 27. EconoMi\$er2 wiring is shown in Fig. 28.

Barometric flow capacity is shown in Fig. 29. Outdoor air leakage is shown in Fig. 30. Return air pressure drop is shown in Fig. 31.

**EconoMi\$er IV Standard Sensors**

**Outdoor Air Temperature (OAT) Sensor**

The outdoor air temperature sensor (HH57AC074) is a 10 to 20 mA device used to measure the outdoor-air temperature. The outdoor-air temperature is used to determine when the EconoMi\$er IV can be used for free cooling. The sensor is factory-installed on the EconoMi\$er IV in the outdoor airstream. (See Fig. 20.) The operating range of temperature measurement is 40° to 100°F.

**Supply Air Temperature (SAT) Sensor**

The supply air temperature sensor is a 3 K thermistor located at the inlet of the indoor fan. (See Fig. 32.) This sensor is factory installed. The operating range of temperature measurement is 0° to 158°F. See Table 3 for sensor temperature/resistance values.

The temperature sensor looks like an eyelet terminal with wires running to it. The sensor is located in the “crimp end” and is sealed from moisture.

**Outdoor Air Lockout Sensor**

The EconoMi\$er IV is equipped with an ambient temperature lockout switch located in the outdoor airstream which is used to lock out the compressors below a 42°F ambient temperature. (See Fig. 20.)

**EconoMi\$er IV Control Modes**

**IMPORTANT:** The optional EconoMi\$er2 does not include a controller. The EconoMi\$er2 is operated by a 4 to 20 mA signal from an existing field-supplied controller (such as PremierLink™ control). See Fig. 28 for wiring information.

Determine the EconoMi\$er IV control mode before set up of the control. Some modes of operation may require different sensors. (See Table 4.) The EconoMi\$er IV is supplied from the factory with a supply-air temperature sensor and an outdoor- air temperature sensor. This allows for operation of the EconoMi\$er IV with outdoor air dry bulb changeover control. Additional accessories can be added to allow for different types of changeover control and operation of the EconoMi\$er IV and unit.

**IMPORTANT:** If the power exhaust accessory is to be installed on the unit, the hood shipped with the unit will not be used and may be discarded. Save the aluminum filter for use in the power exhaust hood assembly.

**Table 3 – Supply Air Sensor Temperature/Resistance Values**

TEMPERATURE (F)	RESISTANCE (ohms)
-58	200,250
-40	100,680
-22	53,010
-4	29,091
14	16,590
32	9,795
50	5,970
68	3,747
77	3,000
86	2,416
104	1,597
122	1,080
140	746
158	525
176	376
185	321
194	274
212	203
230	153
248	116
257	102
266	89
284	70
302	55

**Table 4 – EconoMiSer IV Sensor Usage**

APPLICATION	ECONOMISER IV WITH OUTDOOR AIR DRY BULB SENSOR		
	Accessories Required		
Outdoor Air Dry Bulb	None. The outdoor air dry bulb sensor is factory installed.		
Differential Dry Bulb	CRTEMPSN002A00*		
Single Enthalpy	HH57AC078		
Differential Enthalpy	HH57AC078 and CRENTDIF004A00*		
CO <sub>2</sub> for DCV Control using a Wall-Mounted CO <sub>2</sub> Sensor	33ZCSENCO2		
CO <sub>2</sub> for DCV Control using a Duct-Mounted CO <sub>2</sub> Sensor	33ZCSENCO2† and 33ZCASPCO2**	O R	CRCBDIOX005A00††

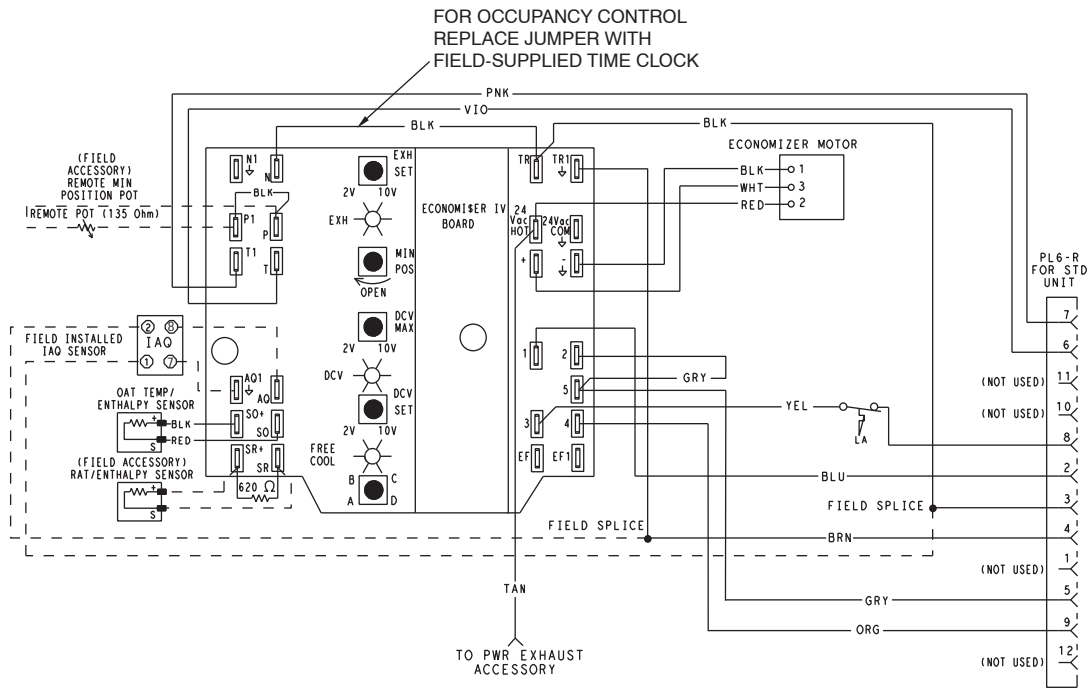
\*CRENTDIF004A00 and CRTEMPSN002A00 accessories are used on many different base units. As such, these kits may contain parts that will not be needed for installation.

† 33ZCSENCO2 is an accessory CO<sub>2</sub> sensor.

\*\* 33ZCASPCO2 is an accessory aspirator box required for duct-mounted applications.

†† CRCBDIOX005A00 is an accessory that contains both 33ZCSENCO2 and 33ZCASPCO2 accessories.

50TM – P06



**LEGEND**  
 DCV— Demand Controlled Ventilation  
 IAQ — Indoor Air Quality  
 LA — Low Ambient Lockout Device  
 OAT — Outdoor-Air Temperature  
 POT — Potentiometer  
 RAT — Return-Air Temperature

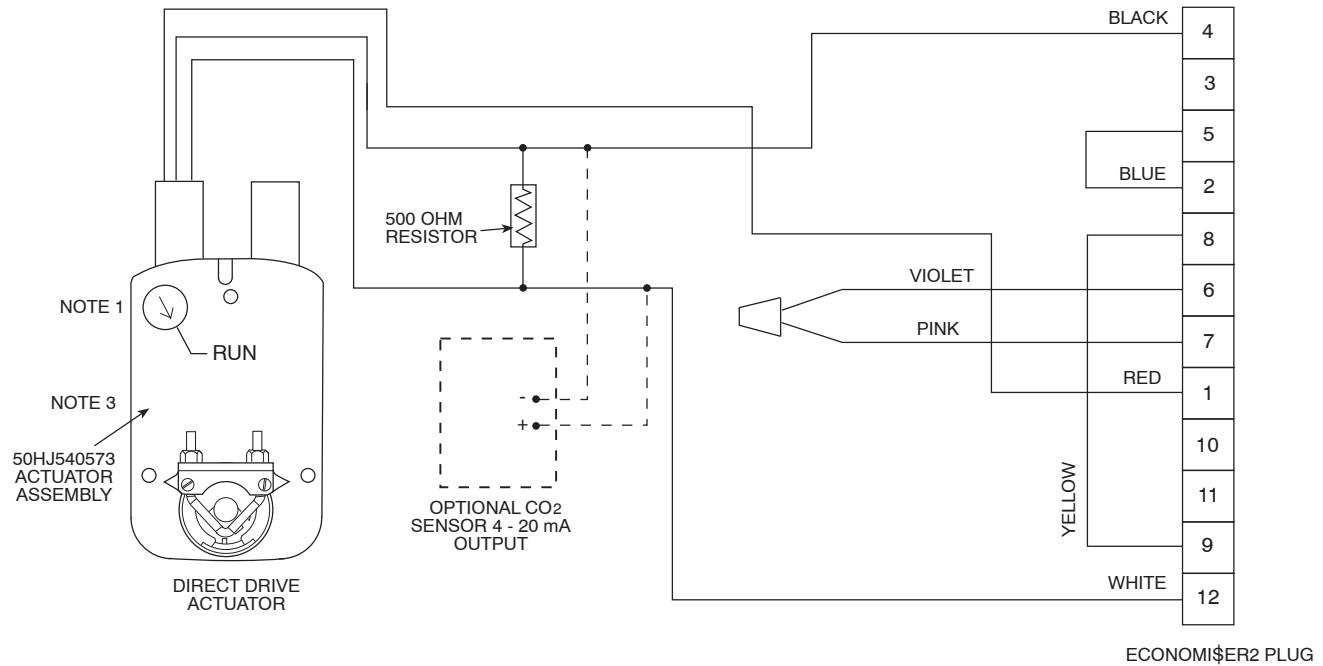
**Potentiometer Defaults Settings:**  
 Power Exhaust Middle  
 Minimum Pos. Fully Closed  
 DCV Max. Middle  
 DCV Set Middle  
 Enthalpy C Setting

**NOTES:**  
 1. 620 ohm, 1 watt 5% resistor should be removed only when using differential enthalpy or dry bulb.  
 2. If a separate field-supplied 24 v transformer is used for the IAQ sensor power supply, it cannot have the secondary of the transformer grounded.  
 3. For field-installed remote minimum position POT, remove black wire jumper between P and P1 and set control minimum position POT to the minimum position.

**Fig. 27 - EconoMiSer IV Wiring**

C06028

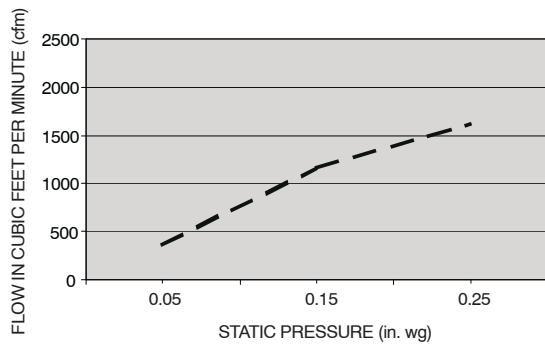




- NOTES:
1. Switch on actuator must be in run position for economizer to operate.
  2. PremierLink™ control requires that the standard 50HJ540569 outside-air sensor be replaced by either the CROASERN001A00 dry bulb sensor or HH57A077 enthalpy sensor.
  3. 50HJ540573 actuator consists of the 50HJ540567 actuator and a harness with 500-ohm resistor.

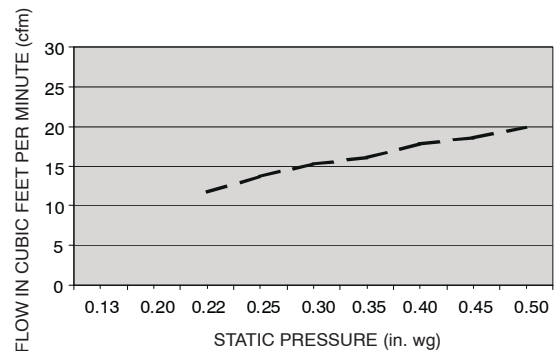
C06029

Fig. 28 - EconoMiSer2 with 4 to 20 mA Control Wiring



C06030

Fig. 29 - Barometric Flow Capacity



C06031

Fig. 30 - Outdoor-Air Damper Leakage

### Outdoor Dry Bulb Changeover

The standard controller is shipped from the factory configured for outdoor dry bulb changeover control. The outdoor air and supply air temperature sensors are included as standard. For this control mode, the outdoor temperature is compared to an adjustable set point selected on the control. If the outdoor-air temperature is above the set point, the EconoMiSer IV will adjust the outside air dampers to minimum position. If the outdoor-air temperature is below the set point, the position of the outside air dampers will be controlled to provide free cooling using outdoor air. When in this mode, the LED next to the free cooling set point potentiometer will be on. The changeover temperature set point is controlled by the free cooling set point potentiometer located on the control. (See Fig. 33.) The scale on the potentiometer is A, B, C, and D. See Fig. 34 for the corresponding temperature changeover values.

### Differential Dry Bulb Control

For differential dry bulb control the standard outdoor dry bulb sensor is used in conjunction with an additional accessory dry bulb sensor (part number CRTEMPSN002A00). The accessory sensor must be mounted in the return airstream. (See Fig. 35.) Wiring is provided in the EconoMiSer IV wiring harness. (See Fig. 27.)

In this mode of operation, the outdoor-air temperature is compared to the return-air temperature and the lower temperature airstream is used for cooling. When using this mode of changeover control, turn the enthalpy setpoint potentiometer fully clockwise to the D setting. (See Fig. 33.)

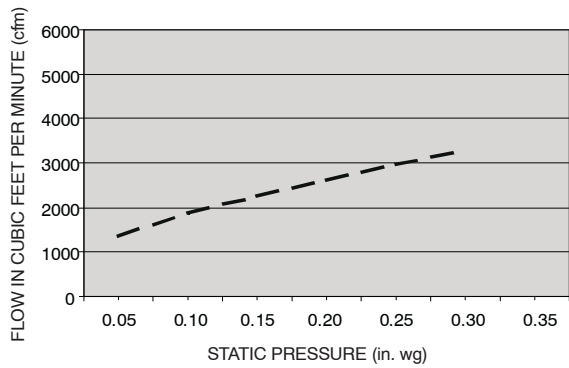


Fig. 31 - Return-Air Pressure Drop

C06032

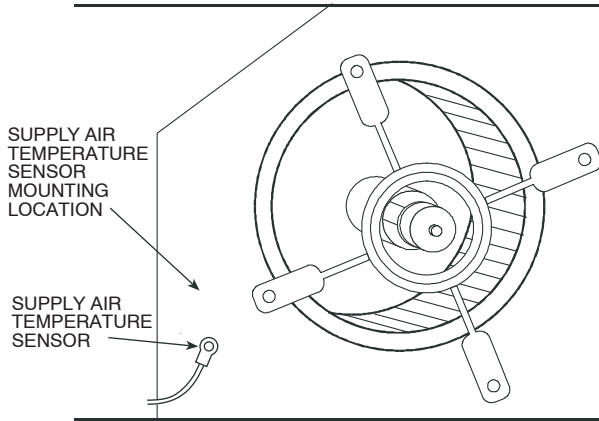


Fig. 32 - Supply Air Sensor Location

C06033

**Outdoor Enthalpy Changeover**

For enthalpy control, accessory enthalpy sensor (part number HH57AC078) is required. Replace the standard outdoor dry bulb temperature sensor with the accessory enthalpy sensor in the same mounting location. (See Fig. 20.) When the outdoor air enthalpy rises above the outdoor enthalpy changeover set point, the outdoor-air damper moves to its minimum position. The outdoor enthalpy changeover set point is set with the outdoor enthalpy set point potentiometer on the EconoMiSer IV controller. The set points are A, B, C, and D. (See Fig. 36.) The factory-installed 620-ohm jumper must be in place across terminals S<sub>R</sub> and S<sub>R+</sub> on the EconoMiSer IV controller. (See Fig. 20 and 37.)

**Differential Enthalpy Control**

For differential enthalpy control, the EconoMiSer IV controller uses two enthalpy sensors (HH57AC078 and CRENTDIF004A00), one in the outside air and one in the return air duct. The EconoMiSer IV controller compares the outdoor air enthalpy to the return air enthalpy to determine EconoMiSer IV use. The controller selects the lower enthalpy air (return or outdoor) for cooling. For example, when the outdoor air has a lower enthalpy than the return air, the EconoMiSer IV opens to bring in outdoor air for free cooling.

Replace the standard outside air dry bulb temperature sensor with the accessory enthalpy sensor in the same mounting location. (See Fig. 20.) Mount the return air enthalpy sensor in the return air duct. (See Fig. 35.) Wiring is provided in the EconoMiSer IV wiring harness. (See Fig. 27.) The outdoor enthalpy changeover set point is set with the outdoor enthalpy set point potentiometer on the EconoMiSer IV controller. When using this mode of changeover control, turn the enthalpy set point potentiometer fully clockwise to the D setting.

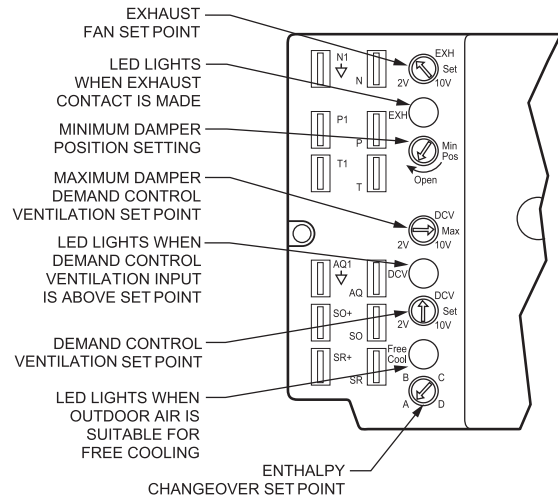


Fig. 33 - EconoMiSer IV Controller Potentiometer and LED Locations

C06034

**Indoor Air Quality (IAQ) Sensor Input**

The IAQ input can be used for demand control ventilation control based on the level of CO<sub>2</sub> measured in the space or return air duct. Mount the accessory IAQ sensor according to manufacturer specifications. The IAQ sensor should be wired to the AQ and AQ1 terminals of the controller. Adjust the DCV potentiometers to correspond to the DCV voltage output of the indoor air quality sensor at the user-determined set point. (See Fig. 38.)

If a separate field-supplied transformer is used to power the IAQ sensor, the sensor must not be grounded or the EconoMiSer IV control board will be damaged.

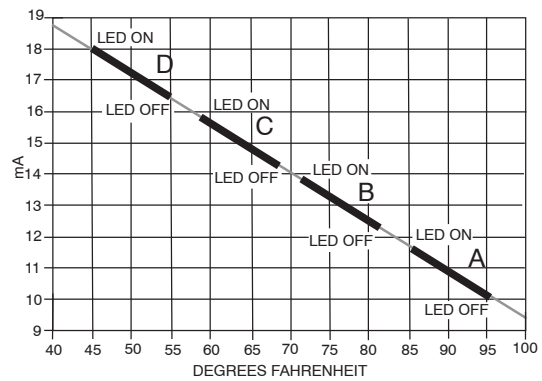
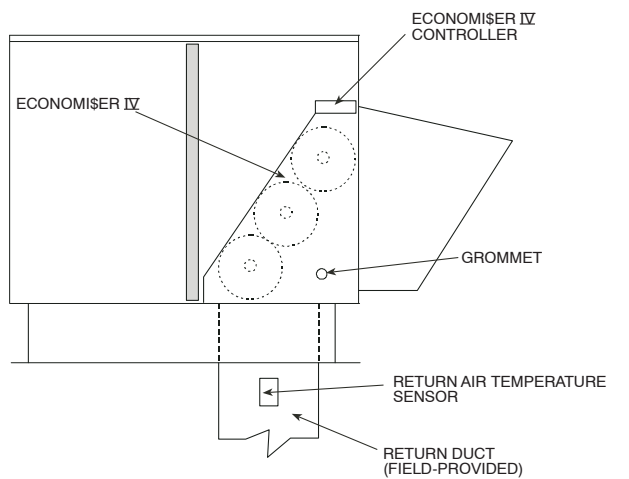


Fig. 34 - Temperature Changeover Set Points

C06035

50TM - P06



C06036

**Fig. 35 - Return Air Temperature or Enthalpy Sensor Mounting Location**

When using demand ventilation, the minimum damper position represents the minimum ventilation position for VOC (volatile organic compounds) ventilation requirements. The maximum demand ventilation position is used for fully occupied ventilation.

When demand ventilation control is not being used, the minimum position potentiometer should be used to set the occupied ventilation position. The maximum demand ventilation position should be turned fully clockwise.

#### Exhaust Set Point Adjustment

The exhaust set point will determine when the exhaust fan runs based on damper position (if accessory power exhaust is installed). The set point is modified with the Exhaust Fan Set Point (EXH SET) potentiometer. (See Fig. 33.) The set point represents the damper position above which the exhaust fans will be turned on. When there is a call for exhaust, the EconoMiSer IV controller provides a  $45 \pm 15$  second delay before exhaust fan activation to allow the dampers to open. This delay allows the damper to reach the appropriate position to avoid unnecessary fan overload.

#### Minimum Position Control

There is a minimum damper position potentiometer on the EconoMiSer IV controller. (See Fig. 33.) The minimum damper position maintains the minimum airflow into the building during the occupied period.

Adjust the minimum position potentiometer to allow the minimum amount of outdoor air, as required by local codes, to enter the building. Make minimum position adjustments with at least  $10^\circ\text{F}$  temperature difference between the outdoor and return-air temperatures.

To determine the minimum position setting, perform the following procedure:

1. Calculate the appropriate mixed air temperature using the following formula:

$$\left(T_O \times \frac{OA}{100}\right) + \left(T_R \times \frac{RA}{100}\right) = T_M$$

$T_O$  = Outdoor-Air Temperature

OA = Percent of Outdoor Air

$T_R$  = Return-Air Temperature

RA = Percent of Return Air

$T_M$  = Mixed-Air Temperature

As an example, if local codes require 10% outdoor air during occupied conditions, outdoor-air temperature is  $60^\circ\text{F}$ , and return-air temperature is  $75^\circ\text{F}$ .

$$(60 \times .10) + (75 \times .90) = 73.5^\circ\text{F}$$

2. Disconnect the mixed air sensor from terminals T and T1.
3. Ensure that the factory-installed jumper is in place across terminals P and P1. If remote damper positioning is being used, make sure that the terminals are wired according to Fig. 27 and that the minimum position potentiometer is turned fully clockwise.
4. Connect 24 vac across terminals TR and TR1.
5. Carefully adjust the minimum position potentiometer until the measured mixed air temperature matches the calculated value.
6. Reconnect the supply air sensor to terminals T and T1.

Remote control of the EconoMiSer IV damper is desirable when requiring additional temporary ventilation. If a field-supplied remote potentiometer (Honeywell part number S963B1128) is wired to the EconoMiSer IV controller, the minimum position of the damper can be controlled from a remote location.

To control the minimum damper position remotely, remove the factory-installed jumper on the P and P1 terminals on the EconoMiSer IV controller. Wire the field-supplied potentiometer to the P and P1 terminals on the EconoMiSer IV controller. (See Fig. 37.)

#### Damper Movement

Damper movement from full open to full closed (or vice versa) takes  $2\frac{1}{2}$  minutes.

#### Thermostats

The EconoMiSer IV control works with conventional thermostats that have a Y1 (cool stage 1), Y2 (cool stage 2), W1 (heat stage 1), W2 (heat stage 2), and G (fan). The EconoMiSer IV control does not support space temperature sensors. Connections are made at the thermostat terminal connection board located in the main control box.

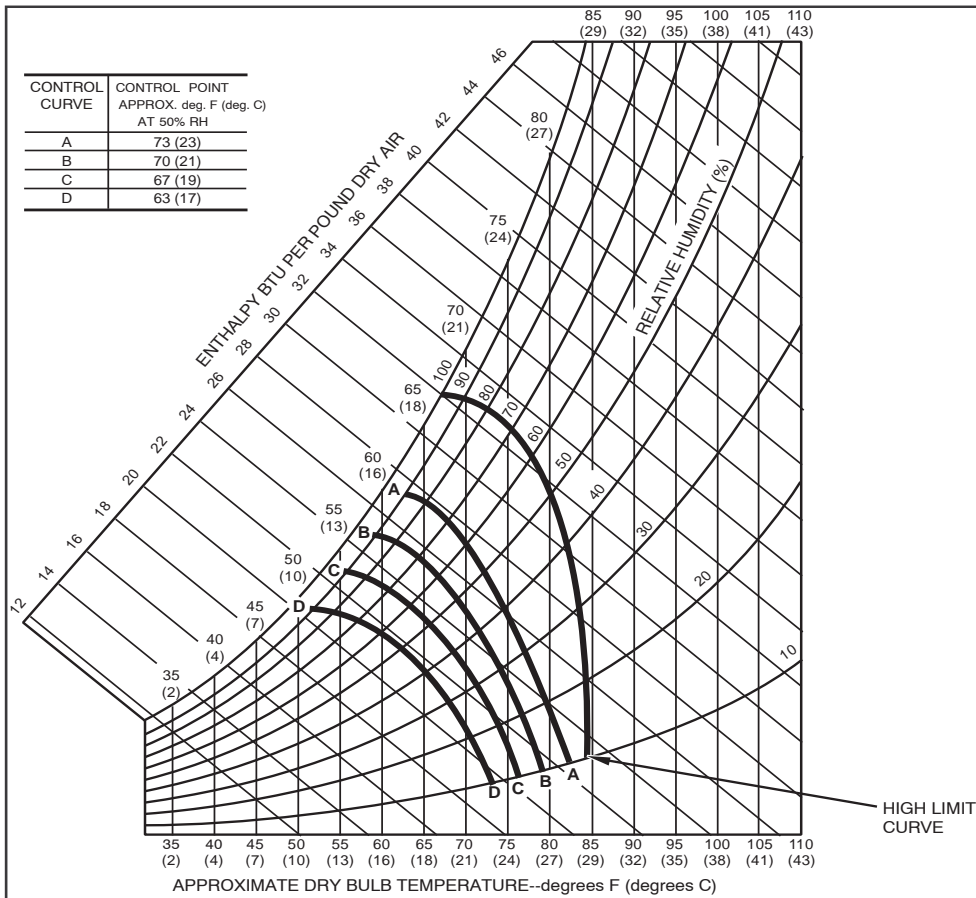


Fig. 36 - Enthalpy Changeover Set Points

C06037

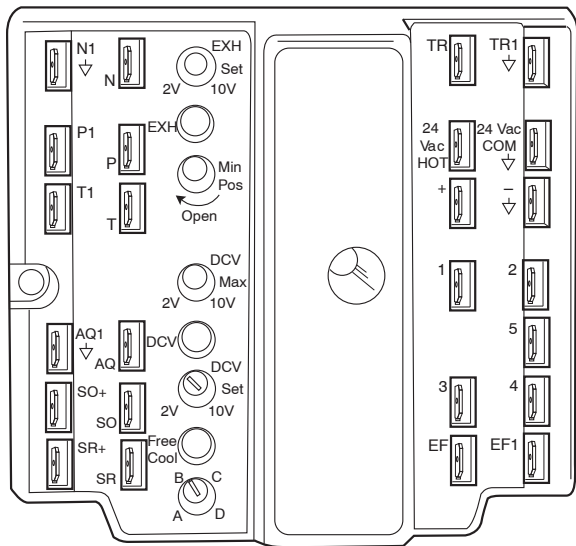


Fig. 37 - EconoMi\$er IV Control

C06038

**Occupancy Control**

The factory default configuration for the EconoMi\$er IV control is occupied mode. Occupied status is provided by the black jumper from terminal TR to terminal N. When unoccupied mode is desired, install a field-supplied timeclock function in place of the jumper between TR and N. (See Fig. 27.) When the timeclock contacts are closed, the EconoMi\$er IV control will be in occupied mode. When the timeclock contacts are open (removing the 24-v signal from terminal N), the EconoMi\$er IV will be in unoccupied mode.

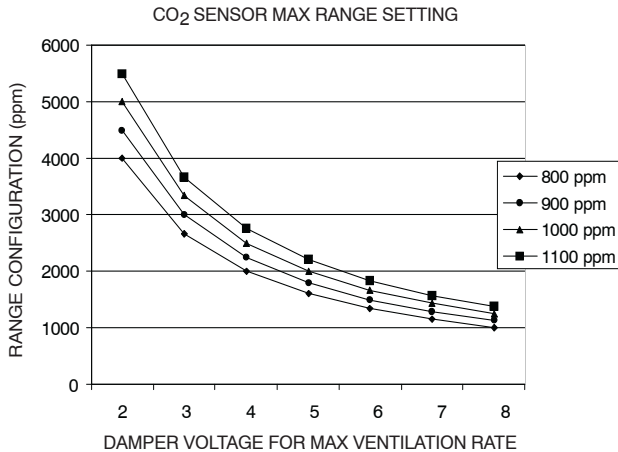


Fig. 38 - CO<sub>2</sub> Sensor Maximum Range Settings

C06039

**Demand Control Ventilation (DCV)**

When using the EconoMi\$er IV for demand controlled ventilation, there are some equipment selection criteria which should be considered. When selecting the heat capacity and cool capacity of the equipment, the maximum ventilation rate must be evaluated for design conditions. The maximum damper position must be calculated to provide the desired fresh air.

Typically the maximum ventilation rate will be about 5 to 10% more than the typical cfm required per person, using normal outside air design criteria.

A proportional anticipatory strategy should be taken with the following conditions: a zone with a large area, varied occupancy, and equipment that cannot exceed the required ventilation rate at design conditions. Exceeding the required ventilation rate means the equipment can condition air at a maximum ventilation rate that is greater than the required ventilation rate for maximum occupancy. A proportional-anticipatory strategy will cause the fresh air supplied to increase as the room CO<sub>2</sub> level increases even though the CO<sub>2</sub> set point has not been reached. By the time the CO<sub>2</sub> level reaches the set point, the damper will be at maximum ventilation and should maintain the set point.

In order to have the CO<sub>2</sub> sensor control the economizer damper in this manner, first determine the damper voltage output for minimum or base ventilation. Base ventilation is the ventilation required to remove contaminants during unoccupied periods. The following equation may be used to determine the percent of outside air entering the building for a given damper position. For best results there should be at least a 10 degree difference in outside and return-air temperatures.

$$(T_O \times \frac{OA}{100}) + (T_R \times \frac{RA}{100}) = T_M$$

T<sub>O</sub> = Outdoor-Air Temperature

OA = Percent of Outdoor Air

T<sub>R</sub> = Return-Air Temperature

RA = Percent of Return Air

T<sub>M</sub> = Mixed-Air Temperature

Once base ventilation has been determined, set the minimum damper position potentiometer to the correct position.

The same equation can be used to determine the occupied or maximum ventilation rate to the building. For example, an output of 3.6 volts to the actuator provides a base ventilation rate of 5% and an output of 6.7 volts provides the maximum ventilation rate of 20% (or base plus 15 cfm per person). Use Fig. 38 to determine the maximum setting of the CO<sub>2</sub> sensor. For example, an 1100 ppm set point relates to a 15 cfm per person design. Use the 1100 ppm curve on Fig. 38 to find the point when the CO<sub>2</sub> sensor output will be 6.7 volts. Line up the point on the graph with the left side of the chart to determine that the range configuration for the CO<sub>2</sub> sensor should be 1800 ppm. The EconoMi\$er IV controller will output the 6.7 volts from the CO<sub>2</sub> sensor to the actuator when the CO<sub>2</sub> concentration in the space is at 1100 ppm. The DCV set point may be left at 2 volts since the CO<sub>2</sub> sensor voltage will be ignored by the EconoMi\$er IV controller until it rises above the 3.6 volt setting of the minimum position potentiometer.

Once the fully occupied damper position has been determined, set the maximum damper demand control ventilation potentiometer to this position. Do not set to the maximum position as this can result in over-ventilation to the space and potential high humidity levels.

### CO<sub>2</sub> Sensor Configuration

The CO<sub>2</sub> sensor has preset standard voltage settings that can be selected anytime after the sensor is powered up. (See Table 5.)

Use setting 1 or 2 for Carrier equipment. (See Table 5.)

1. Press Clear and Mode buttons. Hold at least 5 seconds until the sensor enters the Edit mode.
2. Press Mode twice. The STDSET Menu will appear.

3. Use the Up/Down button to select the preset number. (See Table 6.)

4. Press Enter to lock in the selection.

5. Press Mode to exit and resume normal operation.

The custom settings of the CO<sub>2</sub> sensor can be changed anytime after the sensor is energized. Follow the steps below to change the non-standard settings:

1. Press Clear and Mode buttons. Hold at least 5 seconds until the sensor enters the Edit mode.
2. Press Mode twice. The STDSET Menu will appear.
3. Use the Up/Down button to toggle to the NONSTD menu and press Enter.
4. Use the Up/Down button to toggle through each of the nine variables, starting with Altitude, until the desired setting is reached.
5. Press Mode to move through the variables.
6. Press Enter to lock in the selection, then press Mode to continue to the next variable.

### Dehumidification of Fresh Air with DCV (Demand Controlled Ventilation) Control

Information from ASHRAE indicates that the largest humidity load on any zone is the fresh air introduced. For some applications, a device such as a 62AQ energy recovery unit is added to reduce the moisture content of the fresh air being brought into the building when the enthalpy is high. In most cases, the normal heating and cooling processes are more than adequate to remove the humidity loads for most commercial applications.

If normal rooftop heating and cooling operation is not adequate for the outdoor humidity level, an energy recovery unit and/or a dehumidification option should be considered.

### Step 7 — Adjust Evaporator-Fan Speed

Adjust evaporator-fan rpm to meet jobsite conditions. See Table 6 for fan rpm at motor pulley settings. See Table 7 for motor performance data. See Tables 10 and 11 for accessory and option static pressure drops. Refer to Tables 12-15 to determine fan speed settings.

For units with accessory electric heating, required minimum cfm is 1500.

### Belt-Drive Motors

Fan motor pulleys are factory set for speed shown in Table 1. (See Fig. 39.) To change fan rpm:

1. Shut off unit power supply. Install lockout tag.
2. Loosen belt by loosening fan motor mounting nuts.
3. Loosen movable pulley flange setscrew. (See Fig. 40.)
4. Screw movable flange toward fixed flange to increase fan rpm and away from fixed flange to decrease fan rpm. Increasing fan rpm increases load on motor. Do not exceed maximum speed specified in Table 1.
5. Set movable flange at nearest keyway of pulley hub and tighten setscrew. (See Table 1 for speed change for each full turn of pulley flange.)

**Table 5 – CO<sub>2</sub> Sensor Standard Settings**

SETTING	EQUIPMENT	OUTPUT	VENTILATION RATE (cfm/Person)	ANALOG OUTPUT	CO <sub>2</sub> CONTROL RANGE (ppm)	OPTIONAL RELAY SETPOINT (ppm)	RELAY HYSTERESIS (ppm)
1	Interface w/Standard Building Control System	Proportional	Any	0-10V 4-20 mA	0-2000	1000	50
2		Proportional	Any	2-10V 7-20 mA	0-2000	1000	50
3		Exponential	Any	0-10V 4-20 mA	0-2000	1100	50
4	Economizer	Proportional	15	0-10V 4-20 mA	0-1100	1100	50
5		Proportional	20	0-10V 4-20 mA	0-900	900	50
6		Exponential	15	0-10V 4-20 mA	0-1100	1100	50
7		Exponential	20	0-10V 4-20 mA	0-900	900	50
8	Health & Safety	Proportional	—	0-10V 4-20 mA	0-9999	5000	500
9	Parking/Air Intakes/ Loading Docks	Proportional	—	0-10V 4-20 mA	0-2000	700	50

LEGEND  
ppm -- Parts Per Million

**Table 6 – Fan Rpm at Motor Pulley Settings\***

UNIT	MOTOR PULLEY TURNS OPEN										
	0	1/2	1	1-1/2	2	2-1/2	3	3-1/2	4	4-1/2	5
50TM-P06†	1192	1163	1131	1099	1067	1035	1003	971	909	907	875
50TM-P06**	1685	1647	1608	1570	1531	1493	1454	1416	1377	1339	1300

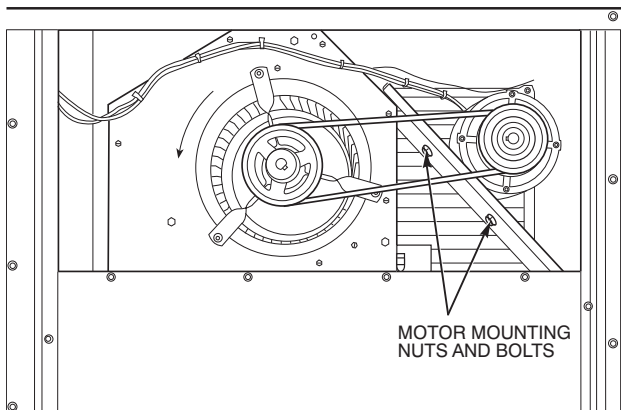
\* Approximate fan rpm shown.  
† Indicates standard motor and drive package.  
\*\* Indicates high-static motor and drive package

To align fan and motor pulleys:

1. Loosen fan pulley setscrews.
2. Slide fan pulley along fan shaft.
3. Make angular alignment by loosening motor from mounting.

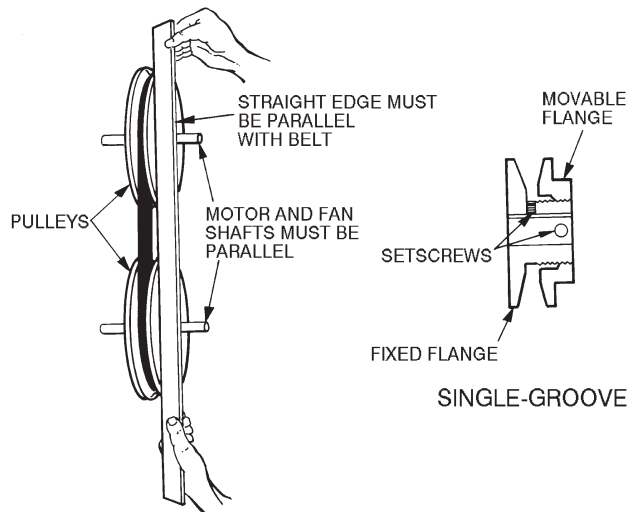
To adjust belt tension:

1. Loosen fan motor mounting nuts.
2. Slide motor mounting plate away from fan scroll for proper belt tension (1/2-in. deflection with 8 to 10 lb of force).
3. Tighten nuts.
4. Adjust bolt and tighten nut to secure motor in fixed position.
5. Re-inspect pulley alignment.



**Fig. 39 - Belt-Drive Motor Mounting**

C07074



**Fig. 40 - Evaporator-Fan Pulley Adjustment**

C07075

**Table 7 – Evaporator-Fan Motor Performance**

UNIT	EVAPORATOR-FAN MOTOR	UNIT VOLTAGE	MAXIMUM ACCEPTABLE CONTINUOUS BHP*	MAXIMUM ACCEPTABLE OPERATING WATTS	MAXIMUM AMP DRAW	EFFICIENCY
50TM-P06	Standard	208/230	2.40	2120	5.2	84
		460			2.6	84
	High Static	208/230	2.90	2562	8.6	84
		460			3.9	84

**LEGEND**

Bhp – Brake Horsepower

\* Extensive motor and electrical testing on these units ensures that the full horsepower range of the motors can be utilized with confidence. Using the fan motors up to the horsepower ratings shown in this table will not result in nuisance tripping or premature motor failure. Unit warranty will not be affected.

**Table 8 – Compressor and Motor Electrical Data**

NOM V-Ph-Hz	COMP (ea)				OFM (ea)				IFM					
	#	TYPE	RLA	LRA	#	WATTS	HP	FLA	TYPE	MAX BHP	Max WATTS	Max AMP Draw	EFF	FLA
208-3-60	1	Scroll	15.6	110.0	1	325	0.25	1.4	STD	2.4	2120	5.2	84%	5.2
									HS	2.9	2562	8.6	84%	7.5
230-3-60	1	Scroll	15.6	110.0	1	325	0.25	1.4	STD	2.4	2120	5.2	84%	5.2
									HS	2.9	2562	8.6	84%	7.5
460-3-60	1	Scroll	7.8	52.0	1	325	0.25	0.8	STD	2.4	2120	2.6	84%	2.6
									HS	2.9	2562	3.9	84%	3.4

**50TM – P06**

Table 9 – Unit Electrical Data

NOM V-Ph-Hz	IFM TYPE	ELEC. HTR			NO C.O.								w/ PWRD C.O.								
		CRHEATER ...	NOM. KW	FLA	NO P.E.		w/ P.E. (pwrd from unit)				NO P.E.		w/ P.E. (pwrd from unit)								
					MCA	MOCP	DISC. SIZE		MCA	MOCP	DISC. SIZE		MCA	MOCP	DISC. SIZE						
				FLA	LRA	MCA	MOCP	FLA	LRA	MCA	MOCP	FLA	LRA	MCA	MOCP	FLA	LRA				
208-3-60	STD	NONE	-	-	26.1	30	26	144	27.8	30	29	146	30.9	35	31	149	32.6	35	34	151	
		002	4.9	13.6	26.1	30	26	144	27.8	30	29	146	30.9	35	31	149	32.6	35	34	151	
		004	7.9	21.9	33.9	35	31	144	35.6	40	34	146	39.9	40	37	149	41.6	45	40	151	
		005	12.0	33.4	48.2	50	44	144	49.9	50	47	146	54.2	60	50	149	55.9	60	53	151	
		(2) 004*	15.8	43.8	61.2	70	56	144	62.9	70	59	146	67.2	70	62	149	68.9	70	65	151	
		004, 005	19.9	55.2	75.6	80	70	144	77.3	80	73	146	81.6	90	75	149	83.3	90	78	151	
	HS	NONE	-	-	28.4	35	28	170	30.1	35	31	172	33.2	40	34	175	34.9	40	37	177	
		002	4.9	13.6	28.4	35	28	170	30.1	35	31	172	33.2	40	34	175	34.9	40	37	177	
		004	7.9	21.9	36.7	40	34	170	38.4	40	37	172	42.7	45	39	175	44.4	45	42	177	
		005	12.0	33.4	51.1	60	47	170	52.8	60	50	172	57.1	60	53	175	58.8	60	56	177	
		(2) 004*	15.8	43.8	64.1	70	59	170	65.8	70	62	172	70.1	80	65	175	71.8	80	68	177	
		004, 005	19.9	55.2	78.4	80	72	170	80.1	90	75	172	84.4	90	78	175	86.1	90	81	177	
	230-3-60	STD	NONE	-	-	26.1	30	26	144	27.8	30	29	146	30.9	35	31	149	32.6	35	34	151
			002	6.5	15.6	26.1	30	26	144	27.8	30	29	146	31.5	35	31	149	33.2	35	34	151
004			10.5	25.3	38.1	40	35	144	39.8	40	38	146	43.5	45	41	149	45.2	50	44	151	
005			16.0	38.5	54.6	60	50	144	56.3	60	53	146	60.0	60	56	149	61.7	60	59	151	
(2) 004*			21.0	50.5	69.6	70	64	144	71.3	80	67	146	75.7	80	70	149	77.4	80	73	151	
004, 005			26.5	63.8	86.2	90	79	144	87.9	90	82	146	91.6	100	85	149	93.3	100	88	151	
HS		NONE	-	-	28.4	35	28	170	30.1	35	31	172	33.2	40	34	174	34.9	40	37	177	
		002	6.5	15.6	28.9	35	28	170	30.6	35	31	172	34.4	40	34	175	36.1	40	37	177	
		004	10.5	25.3	40.9	45	38	170	42.6	45	41	172	46.4	50	43	175	48.1	50	46	177	
		005	16.0	38.5	57.5	60	53	170	59.2	60	56	172	62.9	70	58	175	64.6	70	61	177	
		(2) 004*	21.0	50.5	72.5	80	67	170	74.2	80	70	172	78.5	80	72	175	80.2	90	75	177	
		004, 005	26.5	63.8	89.1	90	82	170	90.8	100	85	172	94.5	100	87	175	96.2	100	90	177	
460-3-60		STD	NONE	-	-	13.2	20	13	69	14.2	20	15	70	15.3	20	15	71	16.3	20	17	72
			002	6.0	7.2	13.2	20	13	69	14.2	20	15	70	15.3	20	15	71	16.3	20	17	72
	004		11.5	13.8	20.5	25	19	69	21.5	25	21	70	23.3	25	21	71	24.3	25	23	72	
	005		14.0	16.8	24.3	25	22	69	25.3	30	24	70	27	30	25	71	28	30	27	72	
	(2) 004*		23.0	27.7	37.8	40	35	69	38.8	40	37	70	40.6	45	37	71	41.6	45	39	72	
	004, 005		25.5	30.7	41.6	45	38	69	42.6	45	40	70	44.3	45	41	71	45.3	50	43	72	
	HS	NONE	-	-	14	20	14	81	15	20	16	82	16.1	20	16	84	17.1	20	18	85	
		002	6.0	7.2	14	20	14	82	15	20	16	83	16.1	20	16	84	17.1	20	18	85	
		004	11.5	13.8	21.5	25	20	82	22.5	25	22	83	24.3	25	22	84	25.3	30	24	85	
		005	14.0	16.8	25.3	30	23	82	26.3	30	25	83	28	30	26	84	29	30	28	85	
		(2) 004*	23.0	27.7	38.8	40	36	82	39.8	40	38	83	41.6	45	38	84	42.6	45	40	85	
		004, 005	25.5	30.7	42.6	45	39	82	43.6	45	41	83	45.3	50	42	84	46.3	50	42	85	

50TM – P06

LEGEND

- FLA – Full Load Amps
- LRA – Locked Rotor Amps
- MCA – Minimum Circuit Amps
- MOCP – Maximum Overcurrent Protection
- NEC – National Electrical Code
- P.E. – Powered Exhaust
- C.C. – Convenience Outlet
- \* Heater capacity (kW) is based on heater voltage of 208 v, 230 v, 480 v, or 600 v. If power distribution voltage to unit varies from rated heater voltage, heater kW will vary accordingly.
- † Fuse or HACR circuit breaker.

NOTES:

1. In compliance with NEC requirements for multimotor and combination load equipment (refer to NEC Articles 430 and 440), the overcurrent protective device for the unit shall be fuse or HACR breaker. Canadian units may be fuse or circuit breaker.
2. **Unbalanced 3-Phase Supply Voltage**  
Never operate a motor where a phase imbalance in supply voltage is greater than 2%. Use the following formula to determine the percentage of voltage imbalance.

Example: Supply voltage is 460-3-60



- AB = 224 v
- BC = 231 v
- AC = 226 v

$$\begin{aligned} \text{Average Voltage} &= \frac{(224 + 231 + 226)}{3} \\ &= \frac{681}{3} \\ &= 227 \end{aligned}$$

Determine maximum deviation from average voltage.

- (AB) 227 – 224 = 3 v
- (BC) 231 – 227 = 4 v
- (AC) 227 – 226 = 1 v

Maximum deviation is 4 v.

Determine percent of voltage imbalance.

$$\begin{aligned} \% \text{ Voltage Imbalance} &= 100 \times \frac{4}{227} \\ &= 1.76\% \end{aligned}$$

This amount of phase imbalance is satisfactory as it is below the maximum allowable 2%.

**IMPORTANT:** If the supply voltage phase imbalance is more than 2%, contact your local electric utility company immediately.





Table 10 – Accessory Electric Heaters Static Pressure Drop (in. wg)

COMPONENT	CFM								
	900	1200	1400	1600	1800	2000	2200	2400	2600
1Heater Module	0.05	0.07	0.09	0.09	0.10	0.11	0.11	0.12	0.13
2Heater Modules	0.15	0.16	0.16	0.16	0.17	0.17	0.17	0.18	0.18

Table 11 – Accessory/FIOP EconoMi\$er IV and EconoMi\$er2 Static Pressure\* (in. wg)

COMPONENT	CFM							
	1250	1500	1750	2000	2250	2500	2750	3000
Vertical EconoMi\$er IV and EconoMi\$er2	0.045	0.065	0.08	0.12	0.145	0.175	0.22	0.255
Horizontal EconoMi\$er IV and EconoMi\$er2	—	—	0.1	0.125	0.15	0.18	0.225	0.275

LEGEND

FIOP – Factory–Installed Option

\* The static pressure must be added to external static pressure. The sum and the evaporator entering air cfm should be used in conjunction with the Fan

Performance tables to determine indoor blower rpm and watts.

GENERAL NOTES FOR FAN PERFORMANCE DATA TABLES

1. Values include losses for filters, unit casing, and wet coils.
2. Extensive motor and electrical testing on these units ensures that the full range of the motor can be utilized with confidence. Using fan motors up to the wattage ratings shown will not result in nuisance tripping or premature motor failure. Unit warranty will not be affected. See Table 7 for additional information.
3. Use of a field-supplied motor may affect wire sizing. Contact your local Carrier representative for details.
4. Interpolation is permissible. Do not extrapolate.

Table 12 – Fan Performance 50TM-P06 — Vertical Discharge; Alternate Motor (Belt Drive)\*- Three-Phase Units

AIRFLOW CFM	EXTERNAL STATIC PRESSURE (in. wg)														
	0.2			0.4			0.6			0.8			1.0		
	Rpm	Bhp	Watts	Rpm	Bhp	Watts	Rpm	Bhp	Watts	Rpm	Bhp	Watts	Rpm	Bhp	Watts
1500	807	0.42	369	913	0.56	489	1011	0.71	621	1103	0.87	766	1188	1.05	923
1600	847	0.49	432	948	0.63	557	1042	0.79	694	1130	0.96	843	1213	1.14	1003
1700	887	0.57	501	983	0.72	632	1073	0.88	774	1158	1.06	928	1239	1.24	1092
1800	928	0.66	579	1020	0.82	715	1106	0.98	863	1188	1.16	1021	1266	1.35	1189
1900	969	0.76	666	1057	0.92	808	1140	1.09	960	1219	1.28	1123	1295	1.48	1296
2000	1010	0.87	761	1095	1.04	909	1175	1.21	1066	1251	1.41	1234	1325	1.61	1411
2100	1052	0.99	866	1133	1.16	1019	1211	1.35	1182	1285	1.54	1355	1355	1.75	1537
2200	1095	1.12	981	1173	1.30	1140	1247	1.49	1308	1319	1.69	1486	1387	1.91	1673
2300	1137	1.26	1105	1212	1.45	1271	1284	1.65	1445	1353	1.85	1628	1420	2.07	1820
2400	1180	1.41	1241	1252	1.61	1412	1322	1.81	1592	1389	2.03	1781	1454	2.25	1977
2500	1223	1.58	1388	1293	1.78	1565	1360	1.99	1751	1425	2.22	1945	—	—	—

AIRFLOW CFM	EXTERNAL STATIC PRESSURE (in. wg)														
	1.2			1.4			1.6			1.8			2.0		
	Rpm	Bhp	Watts	Rpm	Bhp	Watts	Rpm	Bhp	Watts	Rpm	Bhp	Watts	Rpm	Bhp	Watts
1500	1270	1.24	1091	1347	1.45	1269	1421	1.66	1458	1492	1.89	1657	1561	2.13	1865
1600	1292	1.34	1174	1367	1.54	1356	1440	1.76	1547	1509	1.99	1748	1576	2.23	1959
1700	1315	1.44	1267	1389	1.65	1451	1459	1.88	1646	1527	2.11	1849	1593	2.35	2062
1800	1341	1.56	1368	1412	1.77	1556	1481	2.00	1753	1547	2.23	1960	—	—	—
1900	1367	1.68	1478	1437	1.90	1670	1504	2.13	1871	1569	2.37	2080	—	—	—
2000	1395	1.82	1598	1463	2.04	1794	1528	2.28	1998	—	—	—	—	—	—
2100	1424	1.97	1728	1490	2.20	1928	—	—	—	—	—	—	—	—	—
2200	1454	2.13	1869	1518	2.36	2073	—	—	—	—	—	—	—	—	—
2300	1485	2.30	2020	—	—	—	—	—	—	—	—	—	—	—	—
2400	—	—	—	—	—	—	—	—	—	—	—	—	—	—	—
2500	—	—	—	—	—	—	—	—	—	—	—	—	—	—	—

LEGEND

Bhp – Brake Horsepower Input to Fan

Watts – Input Watts to Motor

\*Drive range: 875 to 1192 rpm. All other rpms require field–supplied drive.

NOTES:

1. **Boldface** indicates field–supplied drive is required.
2. Maximum continuous bhp is 2.40.
3. See general fan performance notes.

50TM – P06

Table 13 – Fan Performance 50TM-P06 — Vertical Discharge; High-Static Motor (Belt Drive)\*

AIRFLOW CFM	EXTERNAL STATIC PRESSURE (in. wg)														
	0.2			0.4			0.6			0.8			1.0		
	Rpm	Bhp	Watts	Rpm	Bhp	Watts	Rpm	Bhp	Watts	Rpm	Bhp	Watts	Rpm	Bhp	Watts
1500	807	0.42	369	913	0.56	489	1011	0.71	621	1103	0.87	766	1188	1.05	923
1600	847	0.49	432	948	0.63	557	1042	0.79	694	1130	0.96	843	1213	1.14	1003
1700	887	0.57	501	983	0.72	632	1073	0.88	774	1158	1.06	928	1239	1.24	1092
1800	928	0.66	579	1020	0.82	715	1106	0.98	863	1188	1.16	1021	1266	1.35	1189
1900	969	0.76	666	1057	0.92	808	1140	1.09	960	1219	1.28	1123	1295	1.48	1296
2000	1010	0.87	761	1095	1.04	909	1175	1.21	1066	1251	1.41	1234	1325	1.61	1411
2100	1052	0.99	866	1133	1.16	1019	1211	1.35	1182	1285	1.54	1355	1355	1.75	1537
2200	1095	1.12	981	1173	1.30	1140	1247	1.49	1308	1319	1.69	1486	1387	1.91	1673
2300	1137	1.26	1105	1212	1.45	1271	1284	1.65	1445	1353	1.85	1628	1420	2.07	1820
2400	1180	1.41	1241	1252	1.61	1412	1322	1.81	1592	1389	2.03	1781	1454	2.25	1977
2500	1223	1.58	1388	1293	1.78	1565	1360	1.99	1751	1425	2.22	1945	1488	2.45	2147

AIRFLOW CFM	EXTERNAL STATIC PRESSURE (in. wg)														
	1.2			1.4			1.6			1.8			2.0		
	Rpm	Bhp	Watts	Rpm	Bhp	Watts	Rpm	Bhp	Watts	Rpm	Bhp	Watts	Rpm	Bhp	Watts
1500	1270	1.24	1091	1347	1.45	1269	1421	1.66	1458	1492	1.89	1657	1561	2.13	1865
1600	1292	1.34	1174	1367	1.54	1356	1440	1.76	1547	1509	1.99	1748	1576	2.23	1959
1700	1315	1.44	1267	1389	1.65	1451	1459	1.88	1646	1527	2.11	1849	1593	2.35	2062
1800	1341	1.56	1368	1412	1.77	1556	1481	2.00	1753	1547	2.23	1960	1612	2.48	2175
1900	1367	1.68	1478	1437	1.90	1670	1504	2.13	1871	1569	2.37	2080	1632	2.62	2299
2000	1395	1.82	1598	1463	2.04	1794	1528	2.28	1998	1591	2.52	2212	1653	2.77	2433
2100	1424	1.97	1728	1490	2.20	1928	1554	2.43	2136	1615	2.68	2353	—	—	—
2200	1454	2.13	1869	1518	2.36	2073	1580	2.60	2285	1641	2.85	2505	—	—	—
2300	1485	2.30	2020	1547	2.54	2228	1608	2.79	2445	—	—	—	—	—	—
2400	1516	2.49	2182	1577	2.73	2395	—	—	—	—	—	—	—	—	—
2500	1549	2.69	2357	—	—	—	—	—	—	—	—	—	—	—	—

LEGEND

Bhp – Brake Horsepower Input to Fan  
Watts – Input Watts to Motor

\*Drive range: 1300 to 1685 rpm. All other rpms require field-supplied drive.

NOTES:

1. **Boldface** indicates field-supplied drive is required.
2. Maximum continuous bhp is 2.90.
3. See general fan performance notes.

Table 14 – Fan Performance 50TM-P06 — Three-Phase, Horizontal Discharge Units; Standard Motor (Belt Drive)\*

AIRFLOW CFM	EXTERNAL STATIC PRESSURE (in. wg)														
	0.2			0.4			0.6			0.8			1.0		
	Rpm	Bhp	Watts	Rpm	Bhp	Watts	Rpm	Bhp	Watts	Rpm	Bhp	Watts	Rpm	Bhp	Watts
1500	776	0.38	340	883	0.51	454	977	0.65	579	1061	0.80	715	1138	0.97	860
1600	813	0.45	397	916	0.58	517	1007	0.73	646	1089	0.89	786	1165	1.05	935
1700	851	0.52	461	949	0.66	586	1038	0.81	721	1118	0.97	865	1192	1.15	1018
1800	888	0.60	532	984	0.75	662	1069	0.90	802	1148	1.07	951	1221	1.25	1109
1900	927	0.69	610	1019	0.84	747	1102	1.00	892	1179	1.18	1046	1250	1.36	1208
2000	965	0.78	697	1054	0.94	839	1135	1.11	990	1210	1.29	1149	1280	1.48	1316
2100	1004	0.89	792	1090	1.06	940	1169	1.23	1096	1242	1.42	1260	1310	1.61	1432
2200	1044	1.01	896	1127	1.18	1050	1203	1.36	1211	1274	1.55	1381	1341	1.75	1557
2300	1084	1.14	1009	1164	1.32	1169	1238	1.50	1336	1308	1.70	1511	1373	1.91	1693
2400	1123	1.27	1132	1201	1.46	1298	1273	1.66	1471	1341	1.86	1651	1405	2.07	1838
2500	1164	1.42	1265	1239	1.62	1437	1309	1.82	1616	1375	2.03	1801	1438	2.24	1994

AIRFLOW CFM	EXTERNAL STATIC PRESSURE (in. wg)														
	1.2			1.4			1.6			1.8			2.0		
	Rpm	Bhp	Watts	Rpm	Bhp	Watts	Rpm	Bhp	Watts	Rpm	Bhp	Watts	Rpm	Bhp	Watts
1500	1210	1.14	1014	1278	1.33	1178	1342	1.52	1350	1403	1.72	1530	1461	1.93	1717
1600	1236	1.23	1094	1302	1.42	1261	1365	1.62	1436	1425	1.82	1618	1483	2.04	1809
1700	1262	1.33	1181	1328	1.52	1351	1390	1.72	1530	1449	1.93	1716	1505	2.15	1910
1800	1289	1.44	1276	1354	1.63	1450	1415	1.84	1632	1473	2.05	1822	1529	2.27	2019
1900	1317	1.55	1379	1380	1.75	1557	1441	1.96	1743	1498	2.18	1937	—	—	—
2000	1345	1.68	1491	1408	1.88	1673	1467	2.10	1863	1524	2.32	2060	—	—	—
2100	1375	1.81	1611	1436	2.03	1798	1494	2.24	1993	—	—	—	—	—	—
2200	1405	1.96	1742	1465	2.18	1933	1522	2.40	2132	—	—	—	—	—	—
2300	1435	2.12	1882	1494	2.34	2078	—	—	—	—	—	—	—	—	—
2400	1466	2.29	2032	—	—	—	—	—	—	—	—	—	—	—	—
2500	—	—	—	—	—	—	—	—	—	—	—	—	—	—	—

LEGEND

Bhp – Brake Horsepower Input to Fan  
Watts – Input Watts to Motor

\*Drive range: 815 to 1192 rpm. All other rpms require field-supplied drive.

NOTES:

1. **Boldface** indicates field-supplied drive is required.
2. Maximum continuous bhp is 2.40.
3. See general fan performance notes.

50TM – P06

Table 15 – Fan Performance 50TM-P06 — Horizontal Units; High-Static Motor (Belt Drive)\*

AIRFLOW CFM	EXTERNAL STATIC PRESSURE (in. wg)														
	0.2			0.4			0.6			0.8			1.0		
	Rpm	Bhp	Watts	Rpm	Bhp	Watts	Rpm	Bhp	Watts	Rpm	Bhp	Watts	Rpm	Bhp	Watts
1500	776	0.38	340	883	0.51	454	977	0.65	579	1061	0.80	715	1138	0.97	860
1600	813	0.45	397	916	0.58	517	1007	0.73	646	1089	0.89	786	1165	1.05	935
1700	851	0.52	461	949	0.66	586	1038	0.81	721	1118	0.97	865	1192	1.15	1018
1800	888	0.60	532	984	0.75	662	1069	0.90	802	1148	1.07	951	1221	1.25	1109
1900	927	0.69	610	1019	0.84	747	1102	1.00	892	1179	1.18	1046	1250	1.36	1208
2000	965	0.78	697	1054	0.94	839	1135	1.11	990	1210	1.29	1149	1280	1.48	1316
2100	1004	0.89	792	1090	1.06	940	1169	1.23	1096	1242	1.42	1260	1310	1.61	1432
2200	1044	1.01	896	1127	1.18	1050	1203	1.36	1211	1274	1.55	1381	1341	1.75	1557
2300	1084	1.14	1009	1164	1.32	1169	1238	1.50	1336	1308	1.70	1511	1373	1.91	1693
2400	1123	1.27	1132	1201	1.46	1298	1273	1.66	1471	1341	1.86	1651	1405	2.07	1838
2500	1164	1.42	1265	1239	1.62	1437	1309	1.82	1616	1375	2.03	1801	1438	2.24	1994

AIRFLOW CFM	EXTERNAL STATIC PRESSURE (in. wg)														
	1.2			1.4			1.6			1.8			2.0		
	Rpm	Bhp	Watts	Rpm	Bhp	Watts	Rpm	Bhp	Watts	Rpm	Bhp	Watts	Rpm	Bhp	Watts
1500	1210	1.14	1014	1278	1.33	1178	1342	1.52	1350	1403	1.72	1530	1461	1.93	1717
1600	1236	1.23	1094	1302	1.42	1261	1365	1.62	1436	1425	1.82	1618	1483	2.04	1809
1700	1262	1.33	1181	1328	1.52	1351	1390	1.72	1530	1449	1.93	1716	1505	2.15	1910
1800	1289	1.44	1276	1354	1.63	1450	1415	1.84	1632	1473	2.05	1822	1529	2.27	2019
1900	1317	1.55	1379	1380	1.75	1557	1441	1.96	1743	1498	2.18	1937	1553	2.41	2137
2000	1345	1.68	1491	1408	1.88	1673	1467	2.10	1863	1524	2.32	2060	1579	2.55	2264
2100	1375	1.81	1611	1436	2.03	1798	1494	2.24	1993	1550	2.47	2194	1604	2.70	2401
2200	1405	1.96	1742	1465	2.18	1933	1522	2.40	2132	1578	2.63	2337	1631	2.87	2548
2300	1435	2.12	1882	1494	2.34	2078	1551	2.57	2280	1605	2.80	2490	—	—	—
2400	1466	2.29	2032	1524	2.51	2232	1580	2.75	2440	—	—	—	—	—	—
2500	1498	2.47	2193	1555	2.70	2398	—	—	—	—	—	—	—	—	—

LEGEND

**Bhp** – Brake Horsepower Input to Fan  
**Watts** – Input Watts to Motor

\*Drive range: 1300 to 1685 rpm. All other rpms require field-supplied drive.

NOTES:

1. **Boldface** indicates field-supplied drive is required.
2. Maximum continuous bhp is 2.90.
3. See general fan performance notes.

50TM – P06

## PRE-START-UP

### **WARNING**

#### **ELECTRICAL OPERATION HAZARD**

Failure to observe the following warnings could result in personal injury and/or death:

1. Follow recognized safety practices and wear protective goggles when checking or servicing refrigerant system.
2. Do not operate compressor or provide any electric power to unit unless compressor terminal cover is in place and secured.
3. Do not remove compressor terminal cover until all electrical sources are disconnected.
4. Relieve all pressure from system before touching or disturbing anything inside compressor terminal box if refrigerant leak is suspected around compressor terminals. Use accepted methods to recover refrigerant.
5. Never attempt to repair soldered connection while refrigerant system is under pressure.
6. Do not use torch to remove any component. System contains oil and refrigerant under pressure. To remove a component, wear protective goggles and proceed as follows:
  - a. Shut off electrical power to unit.
  - b. Recover refrigerant to relieve all pressure from system using both high and low-pressure ports.
  - c. Cut component connection tubing with tubing cutter and remove component from unit.
  - d. Carefully unbrazed remaining tubing stubs when necessary. Oil can ignite when exposed to torch flame.

Proceed as follows to inspect and prepare the unit for initial start-up:

1. Remove all access panels.
2. Read and follow instructions on all **WARNING**, **CAUTION**, and **INFORMATION** labels attached to or shipped with unit.
3. Make the following inspections:
  - a. Inspect for shipping and handling damages such as broken lines, loose parts, or disconnected wires.
  - b. Inspect for oil at all refrigerant tubing connections and on unit base. Detecting oil generally indicates a refrigerant leak. Leak-test all refrigerant tubing connections using electronic leak detector, halide torch, or liquid-soap solution.
  - c. Inspect all field-wiring and factory-wiring connections. Be sure that connections are completed and tight. Ensure no electrical wiring is in contact with refrigerant tubing or sharp edges.
  - d. Inspect coil fins. If damaged during shipping and handling, carefully straighten fins with a fin comb.
4. Verify the following conditions:
  - a. Make sure that condenser-fan blades are correctly positioned in fan orifice. Refer to Service and Maintenance Instructions.
  - b. Make sure that air filters are in place.
  - c. Make sure that condensate drain trap is filled with water to ensure proper drainage.

- d. Make sure that all tools and miscellaneous loose parts have been removed.

## START-UP

### **Unit Preparation**

Make sure that unit has been installed in accordance with these installation instructions and applicable codes.

### **Return-Air Filters**

Make sure correct filters are installed in unit. (See Table 1.) Do not operate unit without return-air filters.

### **Compressor Mounting**

Compressors are internally spring mounted. Do not loosen or remove compressor hold-down bolts.

### **Internal Wiring**

Check all electrical connections in unit control boxes; tighten as required. Ensure wiring does not come in contact with sharp metal edges.

### **Refrigerant Service Ports**

To service refrigerant service ports, remove access panel. Each unit system has 2 Schrader-type service ports: one on the suction line and one on the compressor discharge line. Be sure that caps on the ports are tight.

### **Compressor Rotation**

On 50TM-P scroll compressor units, it is important to be certain that the compressor is rotating in the proper direction. To determine whether or not compressor is rotating in the proper direction:

1. Connect service gauges to suction and discharge pressure fittings.
2. Energize the compressor.
3. The suction pressure should drop and the discharge pressure should rise, as is normal on any start-up.

If the suction pressure does not drop and the discharge pressure does not rise to normal levels:

1. Note if the evaporator fan is also rotating in the wrong direction.
2. Turn off power to the unit. Install lockout tag.
3. Reverse any two of the unit power leads.
4. Reapply power to the unit.

The suction and discharge pressure levels should now move to their normal start-up levels.

**NOTE:** When the compressor is rotating in the wrong direction, the unit makes an elevated level of noise and does not provide cooling.

### **Cooling**

Set space thermostat to OFF position. Set system selector switch at COOL position and fan switch at AUTO position. Adjust thermostat to a setting below room temperature. Compressor starts on closure of contactor.

Check cooling effects at a setting below room temperature. Check unit charge. Refer to Service and Maintenance Instructions.

Reset thermostat at a position above room temperature. Compressor will shut off.

### **To Shut Off Unit**

Set system selector switch at OFF position. Resetting thermostat at a position above room temperature shuts unit off temporarily until space temperature exceeds thermostat setting. Units are equipped with Cycle-LOC™ protection device. Unit shuts down on any safety trip and remains off; an indicator light on the thermostat comes on. Check reason for safety trip.

Compressor restart is accomplished by manual reset at the thermostat by turning the selector switch to OFF position and then ON position.

## Safety Relief

A soft solder joint in the suction line at the low-pressure service port provides pressure relief under abnormal temperature and pressure conditions.

## Ventilation (Continuous Fan)

Set fan and system selector switches at ON and OFF positions, respectively. Evaporator fan operates continuously to provide constant air circulation.

## Operating Sequence

### Cooling, Units Without Any Economizer

When thermostat calls for cooling, terminals G and Y1 are energized. The indoor-fan contactor (IFC) and compressor contactor are energized and indoor-fan motor, compressor, and outdoor fan starts. The outdoor-fan motor runs continuously while unit is cooling.

### Heating, Units Without Any Economizer

Upon a request for heating from the space thermostat, terminal W1 will be energized with 24 v. The IFC and heater contactor (HC1) are energized.

### Cooling, Units With EconoMiSer IV

When free cooling is not available, the compressors will be controlled by the zone thermostat. When free cooling is available, the outdoor-air damper is modulated by the EconoMiSer IV control to provide a 50° to 55°F supply-air temperature into the zone. As the supply-air temperature fluctuates above 55° or below 50°F, the dampers will be modulated (open or close) to bring the supply-air temperature back within the set point limits.

Integrated EconoMiSer IV operation on single-stage units requires a 2-stage thermostat (Y1 and Y2).

For EconoMiSer IV operation, there must be a thermostat call for the fan (G). This will move the damper to its minimum position during the occupied mode.

If the increase in cooling capacity causes the supply-air temperature to drop below 45°F, then the outdoor-air damper position will be fully closed. If the supply-air temperature continues to fall, the outdoor-air damper will close. Control returns to normal once the supply-air temperature rises above 48°F.

If optional power exhaust is installed, as the outdoor-air damper opens and closes, the power exhaust fans will be energized and deenergized.

If field-installed accessory CO<sub>2</sub> sensors are connected to the EconoMiSer IV control, a demand controlled ventilation strategy will begin to operate. As the CO<sub>2</sub> level in the zone increases above the CO<sub>2</sub> set point, the minimum position of the damper will be increased proportionally. As the CO<sub>2</sub> level decreases because of the increase in fresh air, the outdoor-air damper will be proportionally closed. Damper position will follow the higher demand condition from DCV mode or free cooling mode.

Damper movement from full closed to full open (or vice versa) will take between 1-1/2 and 2-1/2 minutes.

If free cooling can be used as determined from the appropriate changeover command (switch, dry bulb, enthalpy curve, differential dry bulb, or differential enthalpy), a call for cooling (Y1 closes at the thermostat) will cause the control to modulate the dampers open to maintain the supply air temperature set point at 50° to 55°F.

As the supply-air temperature drops below the set point range of 50° to 55°F, the control will modulate the outdoor-air dampers closed to maintain the proper supply-air temperature.

### Heating, Units With EconoMiSer IV

When the room temperature calls for heat, the heating controls are energized as described in the Heating, Units Without Economizer section. When the thermostat is satisfied, the economizer damper moves to the minimum position.

### Cooling, Units With EconoMiSer2, PremierLink™ Control and a Thermostat

When free cooling is not available, the compressors will be controlled by the PremierLink control in response to the Y1 and Y2 inputs from the thermostat.

The PremierLink control will use the following information to determine if free cooling is available:

- Indoor fan has been on for at least 30 seconds.
- The SPT, SAT, and OAT inputs must have valid readings.
- OAT must be less than 75°F.
- OAT must be less than SPT.
- Enthalpy must be LOW (may be jumpered if an enthalpy sensor not available).
- Economizer position is NOT forced.

Pre-cooling occurs when there is no call from the thermostat except G. Pre-cooling is defined as the economizer modulates to provide 70°F supply air.

When free cooling is available the PremierLink control will control the compressors and economizer to provide a supply-air temperature determined to meet the Y1 and Y2 calls from the thermostat using the following three routines. The three control routines are based on OAT.

The 3 routines are based on OAT where:

SASP = Supply Air Set Point

DXCTLO = Direct Expansion Cooling Lockout Set Point

PID = Proportional Integral

#### **Routine 1 (OAT < DXCTLO)**

- Y1 energized - economizer maintains a SASP = (SATLO1 + 3).
- Y2 energized - economizer maintains a SASP = (SATLO2 + 3).

#### **Routine 2 (DXCTLO < OAT < 68°F)**

- If only Y1 energized, the economizer maintains a SASP = (SATLO1 + 3).
- If SAT > SASP + 5 and economizer position > 80%, economizer will go to minimum position for 3 minutes or until SAT > 68°F.
- First stage of mechanical cooling will be energized.
- Integrator resets.
- Economizer opens again and controls to current SASP after stage one on for 90 seconds.
- With Y1 and Y2 energized Economizer maintains an SASP = SATLO2 + 3.
- If SAT > SASP + 5 and economizer position > 80%, economizer will go to minimum position for 3 minutes or until SAT > 68°F.
- If compressor one is on, then second stage of mechanical cooling will be energized. Otherwise the first stage will be energized.
- Integrator resets.
- Economizer opens again and controls to SASP after stage one on for 90 seconds.

**Routine 3 (OAT > 68)**

- Economizer is opened 100%.
- Compressors 1 and 2 are cycled based on Y1 and Y2 using minimum on and off times and watching the supply air temperature as compared to SATLO1 and SATLO2 set points.

If optional power exhaust is installed, as the outdoor-air damper opens and closes, the power exhaust fans will be energized and deenergized.

If field-installed accessory CO<sub>2</sub> sensors are connected to the PremierLink™ control, a PID-controlled demand ventilation strategy will begin to operate. As the CO<sub>2</sub> level in the zone increases above the CO<sub>2</sub> set point, the minimum position of the damper will be increased proportionally. As the CO<sub>2</sub> level decreases because of the increase in fresh air, the outdoor-air damper will be proportionally closed.

**Heating, Units With EconoMi\$er2, PremierLink™ Control and a Thermostat**

When the thermostat calls for heating, terminal W1 is energized. The PremierLink control will move the economizer damper to the minimum position if there is a call for G and closed if there is a call for W1 without G. The IFC and heater contactor (HC1) are energized.

When the thermostat is satisfied and W1 is deenergized, the IFM stops after a 45-second time-off delay unless G is still maintained.

**Cooling, Units With EconoMi\$er2, PremierLink Control and a Room Sensor**

When free cooling is not available, the compressors will be controlled by the PremierLink controller using a PID Error reduction calculation as indicated by Fig 41.

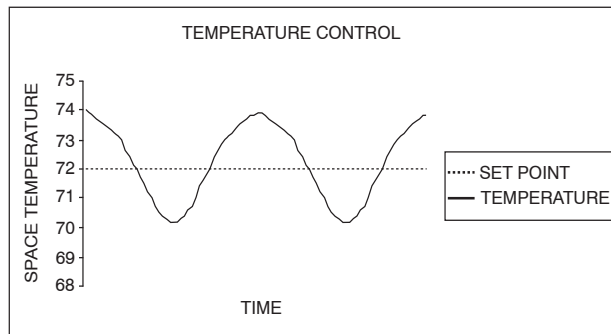
The PremierLink controller will use the following information to determine if free cooling is available:

- Indoor fan has been on for at least 30 seconds.
- The SPT, SAT, and OAT inputs must have valid readings.
- OAT must be less than 75°F.
- OAT must be less than SPT.
- Enthalpy must be LOW (may be jumpered if an enthalpy sensor is not available).
- Economizer position is NOT forced.

When free cooling is available, the outdoor-air damper is positioned through the use of a Proportional Integral (PID) control process to provide a calculated supply-air temperature into the zone. The supply air will maintain the space temperature between the heating and cooling set points as indicated in Fig. 42.

The PremierLink controller will integrate the compressors stages with the economizer based on similar logic as the three routines listed in the previous section. The SASP will float up and down based on the error reduction calculations that compare space temperature and space set point.

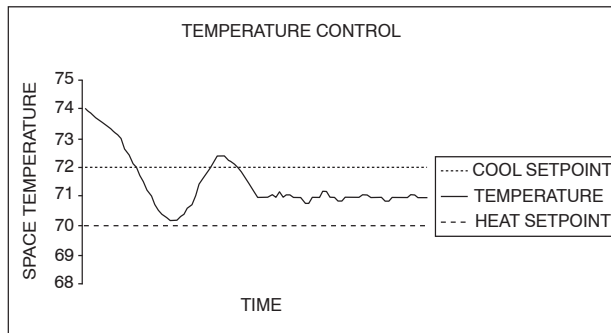
When outside-air temperature conditions require the economizer to close for a compressor stage-up sequence, the economizer control integrator is reset to zero after the stage-up sequence is completed. This prevents the supply-air temperature from dropping too quickly and creating a freeze condition that would make the compressor turn off prematurely.



NOTE: PremierLink control performs smart staging of 2 stages of DX cooling and up to 3 stages of heat.

C06042

**Fig. 41 - DX Cooling Temperature Control Example**



C06043

**Fig. 42 - Economizer Temperature Control Example**

The high space set point is used for DX (direct expansion) cooling control, while the economizer space set point is a calculated value between the heating and cooling set points. The economizer set point will always be at least one degree below the cooling set point, allowing for a smooth transition from mechanical cooling with economizer assist, back to economizer cooling as the cooling set point is achieved. The compressors may be used for initial cooling then the PremierLink controller will modulate the economizer using an error reduction calculation to hold the space temperature between the heating and cooling set points. (See Fig. 42.)

The controller uses the following conditions to determine economizer cooling:

- Enthalpy is Low
- SAT reading is available
- OAT reading is available
- SPT reading is available
- $OAT \leq SPT$
- Economizer Position is NOT forced

If any of the above conditions are not met, the economizer submaster reference (ECSR) is set to maximum limit and the damper moves to minimum position. The operating sequence is complete. The ECSR is recalculated every 30 seconds.

If an optional power exhaust is installed, as the outdoor-air damper opens and closes, the power exhaust fans will be energized and deenergized.

If field-installed accessory CO<sub>2</sub> sensors are connected to the PremierLink™ control, a PID-controlled demand ventilation strategy will begin to operate. As the CO<sub>2</sub> level in the zone increases above the CO<sub>2</sub> set point, the minimum position of the damper will be increased proportionally. As the CO<sub>2</sub> level decreases because of the increase in fresh air, the outdoor-air damper will be proportionally closed.

### **Heating, Units With EconoMi\$er2, PremierLink™ Control and a Room Sensor**

Every 40 seconds the controller will calculate the required heat stages (maximum of 3) to maintain supply-air temperature (SAT) if the following qualifying conditions are met:

- Indoor fan has been on for at least 30 seconds.
- COOL mode is not active.
- OCCUPIED, TEMP.COMPENSATED START or HEAT mode is active.
- SAT reading is available.
- Fire shutdown mode is not active.

If all of the above conditions are met, the number of heat stages is calculated; otherwise the required number of heat stages will be set to 0.

If the PremierLink controller determines that heat stages are required, the economizer damper will be moved to minimum position if occupied and closed if unoccupied.

Staging should be as follows:

#### **If Heating PID STAGES=2**

- HEAT STAGES=1 (50% capacity) will energize HS1
- HEAT STAGES=2 (100% capacity) will energize HS2

#### **If Heating PID STAGES=3 and AUXOUT = HS3**

- HEAT STAGES=1 (33% capacity) will energize HS1
- HEAT STAGES=2 (66% capacity) will energize HS2
- HEAT STAGES=3 (100% capacity) will energize HS3

## **TROUBLESHOOTING**

### **Unit Troubleshooting**

Refer to Fig. 43 for unit troubleshooting information.

### **EconoMi\$er IV Troubleshooting**

An EconoMi\$er IV simulator program is available from Carrier to help with EconoMi\$er IV training and troubleshooting.

#### **EconoMi\$er IV Preparation**

This procedure is used to prepare the EconoMi\$er IV for troubleshooting. No troubleshooting or testing is done by performing the following procedure.

**NOTE:** This procedure requires a 9-v battery, 1.2 kilo-ohm resistor, and a 5.6 kilo-ohm resistor which are not supplied with the EconoMi\$er IV.

**IMPORTANT:** Be sure to record the positions of all potentiometers before starting troubleshooting.

1. Disconnect power at TR and TR1. All LEDs should be off. Exhaust fan contacts should be open.
2. Disconnect device at P and P1.
3. Jumper P to P1.
4. Disconnect wires at T and T1. Place 5.6 kilo-ohm resistor across T and T1.
5. Jumper TR to 1.
6. Jumper TR to N.
7. If connected, remove sensor from terminals S<sub>O</sub> and +. Connect 1.2 kilo-ohm 4074EJM checkout resistor across terminals S<sub>O</sub> and +.
8. Put 620-ohm resistor across terminals S<sub>R</sub> and +.

9. Set minimum position, DCV set point, and exhaust potentiometers fully CCW (counterclockwise).
10. Set DCV maximum position potentiometer fully CW (clockwise).
11. Set enthalpy potentiometer to D.
12. Apply power (24 vac) to terminals TR and TR1.

#### **Differential Enthalpy**

To check differential enthalpy:

1. Make sure EconoMi\$er IV preparation procedure has been performed.
2. Place 620-ohm resistor across S<sub>O</sub> and +.
3. Place 1.2 kilo-ohm resistor across S<sub>R</sub> and +. The Free Cool LED should be lit.
4. Remove 620-ohm resistor across S<sub>O</sub> and +. The Free Cool LED should turn off.
5. Return EconoMi\$er IV settings and wiring to normal after completing troubleshooting.

#### **Single Enthalpy**

To check single enthalpy:

1. Make sure EconoMi\$er IV preparation procedure has been performed.
2. Set the enthalpy potentiometer to A (fully CCW). The Free Cool LED should be lit.
3. Set the enthalpy potentiometer to D (fully CW). The Free Cool LED should turn off.
4. Return EconoMi\$er IV settings and wiring to normal after completing troubleshooting.

#### **DCV (Demand Control Ventilation) and Power**

##### **Exhaust**

To check DCV and Power Exhaust:

1. Make sure EconoMi\$er IV preparation procedure has been performed.
2. Ensure terminals AQ and AQ1 are open. The LED for both DCV and Exhaust should be off. The actuator should be fully closed.
3. Connect a 9V battery to AQ (positive node) and AQ1 (negative node). The LED for both DCV and Exhaust should turn on. The actuator should drive to between 90 and 95% open.
4. Turn the Exhaust potentiometer CW until the Exhaust LED turns off. The LED should turn off when the potentiometer is approximately 90%. The actuator should remain in position.
5. Turn the DCV set point potentiometer CW until the DCV LED turns off. The DCV LED should turn off when the potentiometer is approximately 9-v. The actuator should drive fully closed.
6. Turn the DCV and Exhaust potentiometers CCW until the Exhaust LED turns on. The exhaust contacts will close 30 to 120 seconds after the Exhaust LED turns on.
7. Return EconoMi\$er IV settings and wiring to normal after completing troubleshooting.

##### **DCV Minimum and Maximum Position**

To check the DCV minimum and maximum position:

1. Make sure EconoMi\$er IV preparation procedure has been performed.
2. Connect a 9-v battery to AQ (positive node) and AQ1 (negative node). The DCV LED should turn on. The actuator should drive to between 90 and 95% open.
3. Turn the DCV Maximum Position potentiometer to midpoint. The actuator should drive to between 20 and 80% open.

4. Turn the DCV Maximum Position potentiometer to fully CCW. The actuator should drive fully closed.
5. Turn the Minimum Position potentiometer to midpoint. The actuator should drive to between 20 and 80% open.
6. Turn the Minimum Position Potentiometer fully CW. The actuator should drive fully open.
7. Remove the jumper from TR and N. The actuator should drive fully closed.
8. Return EconoMiSer IV settings and wiring to normal after completing troubleshooting.

### **Supply-Air Input**

To check supply-air input:

1. Make sure EconoMiSer IV preparation procedure has been performed.
2. Set the Enthalpy potentiometer to A. The Free Cool LED turns on. The actuator should drive to between 20 and 80% open.
3. Remove the 5.6 kilo-ohm resistor and jumper T to T1. The actuator should drive fully open.
4. Remove the jumper across T and T1. The actuator should drive fully closed.
5. Return EconoMiSer IV settings and wiring to normal after completing troubleshooting.

### **EconoMiSer IV Troubleshooting Completion**

This procedure is used to return the EconoMiSer IV to operation. No troubleshooting or testing is done by performing the following procedure.

1. Disconnect power at TR and TR1.
2. Set enthalpy potentiometer to previous setting.
3. Set DCV maximum position potentiometer to previous setting.
4. Set minimum position, DCV set point, and exhaust potentiometers to previous settings.
5. Remove 620-ohm resistor from terminals S<sub>R</sub> and +.
6. Remove 1.2 kilo-ohm checkout resistor from terminals S<sub>O</sub> and +. If used, reconnect sensor from terminals S<sub>O</sub> and +.
7. Remove jumper from TR to N.
8. Remove jumper from TR to 1.
9. Remove 5.6 kilo-ohm resistor from T and T1. Reconnect wires at T and T1.
10. Remove jumper from P to P1. Reconnect device at P and P1.
11. Apply power (24 vac) to terminals TR and TR1.





## SERVICE TRAINING

**Packaged Service Training** programs are an excellent way to increase your knowledge of the equipment discussed in this manual, including:

- Unit Familiarization
- Maintenance
- Installation Overview
- Operating Sequence

A large selection of product, theory, and skills programs are available using popular video-based formats and materials. All include video and/or slides, plus companion book.

**Classroom Service Training** which includes “hands-on” experience with the products in our labs can mean increased confidence that really pays dividends in faster troubleshooting and fewer callbacks. Course descriptions and schedules are in our catalog.

**CALL FOR FREE CATALOG 1-800-644-5544**

Packaged Service Training       Classroom Service Training

# START-UP CHECKLIST

(Remove and Store in Job File)

## I. PRELIMINARY INFORMATION:

MODEL NO.: \_\_\_\_\_ SERIAL NO.: \_\_\_\_\_  
DATE: \_\_\_\_\_ TECHNICIAN: \_\_\_\_\_  
BUILDING LOCATION: \_\_\_\_\_

## II. PRE-START-UP (Insert checkmark in box as each item is completed):

- VERIFY THAT CONDENSATE CONNECTION IS INSTALLED AS SHOWN IN THE INSTALLATION INSTRUCTIONS
- CHECK ALL ELECTRICAL CONNECTIONS AND TERMINALS FOR TIGHTNESS
- CHECK THAT RETURN-AIR FILTERS ARE CLEAN AND IN PLACE
- CHECK THAT OUTDOOR AIR INLET SCREENS ARE IN PLACE
- VERIFY THAT UNIT INSTALLATION IS LEVEL WITHIN TOLERANCES LISTED IN THE INSTALLATION INSTRUCTIONS
- CHECK FAN WHEEL AND PROPELLER FOR LOCATION IN HOUSING/ORIFICE, AND SETSCREW TIGHTNESS
- CHECK PULLEY ALIGNMENT AND BELT TENSION; REFER TO INSTALLATION INSTRUCTIONS
- CHECK TO ENSURE THAT ELECTRICAL WIRING IS NOT IN CONTACT WITH REFRIGERANT LINES OR SHARPMETAL EDGES.

## II. START-UP

### ELECTRICAL

SUPPLY VOLTAGE	L1-L2	_____	L2-L3	_____	L3-L1	_____
COMPRESSOR AMPS	L1	_____	L2	_____	L3	_____
INDOOR FAN AMPS	L1	_____	L2	_____	L3	_____

### TEMPERATURES

OUTDOOR-AIR TEMPERATURE	_____	DB		
RETURN-AIR TEMPERATURE	_____	DB	_____	WB
COOLING SUPPLY AIR	_____	DB	_____	WB

### REFRIGERANT

REFRIGERANT SUCTION	_____	PSIG	_____	F
REFRIGERANT DISCHARGE	_____	PSIG	_____	F

### GENERAL

- VERIFY 3-PHASE SCROLL COMPRESSOR IS ROTATING IN THE CORRECT DIRECTION

50TM -- P06

