

**50VR–A and 50VR–C
Performance™ 15 SEER 2–Stage Packaged Heat Pump
System with Puron® (R–410A) Refrigerant
Single and Three Phase
2–5 Nominal Tons (Sizes 24–60)**



Installation Instructions

IMPORTANT: Effective January 1, 2015, all split system and packaged air conditioners must be installed pursuant to applicable regional efficiency standards issued by the Department of Energy.

NOTE: Read the entire instruction manual before starting the installation.

NOTE: Installer: Make sure the Owner’s Manual and Service Instructions are left with the unit after installation.

TABLE OF CONTENTS

	PAGE
SAFETY CONSIDERATIONS	1
INTRODUCTION	2
RECEIVING AND INSTALLATION	2-10
Check Equipment	2
Identify Unit	2
Inspect Shipment	2
Provide Unit Support	2
Roof Curb	2
Slab Mount	2
Provide Clearances	6
Field Fabricate Ductwork	6
Rig and Place Unit	6
Inspection	7
Rigging/Lifting of Unit	7
Connect Condensate Drain	7
Install Duct Connections	7
Configuring Units for Downflow (Vertical) Discharge	8
Install Electrical Connections	8
High-Voltage Connections	9
Special Procedures for 208v Operation	9
Control Voltage Connections	9
Standard Connection	9
Transformer Protection	9
PRE-START-UP	11
START-UP	11-13
Check Cooling and Heating Control Operation	11
Check for Refrigerant Leaks	11
Start-Up Adjustments	12
Checking and Adjusting Refrigerant Charge	12
Indoor Airflow and Airflow Adjustments	12
Low Stage Cooling	13
High Stage Cooling	13
High Stage Enhanced Dehumidification Cooling (208/230 Vac Models)	13
Continuous Fan	13
Sequence of Operation	13
Defrost Control	13
Quiet Shift	13
Defrost	13
MAINTENANCE	32-35
Air Filter	32
Indoor Blower and Motor	32
Outdoor Coil, Indoor Coil, and Condensate Drain Pan	33
Outdoor Fan	33

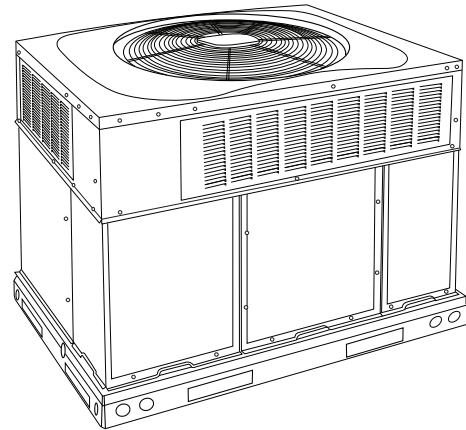

A09033

Fig. 1 - Unit 50VR

Electrical Controls and Wiring	33
Refrigerant Circuit	34
Evaporator Airflow	34
Metering Device	34
System Information	35
Loss of Charge Switch	35
Check Defrost Thermostat	35
TROUBLESHOOTING	35
START-UP CHECKLIST	35

SAFETY CONSIDERATIONS

Improper installation adjustment, alteration, service, maintenance, or use can cause explosion, fire, electrical shock, or other conditions which may cause death, personal injury, or property damage. Consult a qualified installer, service agency, or your distributor or branch for information or assistance. The qualified installer or agency must use factory-authorized kits or accessories when modifying this product. Refer to the individual instructions packaged with the kits or accessories when installing.

Follow all safety codes. Wear safety glasses, protective clothing, and work gloves. Use quenching cloth for brazing operations. Have a fire extinguisher available. Read these instructions thoroughly and follow all warnings or cautions included in literature and attached to the unit. Consult local building codes, the current editions of the National Electrical Code (NEC) NFPA 70. In Canada refer to the current editions of the Canadian electrical Code CSA C22.1.

Recognize safety information. This is the safety-alert symbol . When you see this symbol on the unit and in instructions or manuals, be alert to the potential for personal injury. Understand these signal words; DANGER, WARNING, and CAUTION. These words are used with the safety-alert symbol. DANGER identifies the most serious hazards which **will** result in severe personal injury or death. WARNING signifies hazards which **could** result in personal injury or death. CAUTION is used to identify unsafe practices which **may** result in minor personal injury or product and property damage. NOTE is used to highlight suggestions which **will** result in enhanced installation, reliability, or operation.

⚠ WARNING

ELECTRICAL SHOCK HAZARD

Failure to follow this warning could result in personal injury or death.

Before installing or servicing system, always turn off main power to system and install lockout tag. There may be more than one disconnect switch. Turn off accessory heater power switch if applicable.

⚠ WARNING

PERSONAL INJURY AND ENVIRONMENTAL HAZARD

Failure to relieve system pressure could result in personal injury and/or death.

1. Relieve pressure and recover all refrigerant before servicing existing equipment, and before final unit disposal. Use all service ports and open all flow-control devices, including solenoid valves.
2. Federal regulations require that you do not vent refrigerant into the atmosphere. Recover during system repair or final unit disposal.

⚠ CAUTION

CUT HAZARD

Failure to follow this caution may result in personal injury.

When removing access panels (see Fig. 17) or performing maintenance functions inside your unit, be aware of sharp sheet metal parts and screws. Although special care is taken to reduce sharp edges to a minimum, be extremely careful and wear appropriate protective clothing, safety glasses and gloves when handling parts or reaching into the unit.

INTRODUCTION

This packaged heat pump is fully self-contained and designed for outdoor installation (See Fig. 1). See Fig. 2 and 3 for unit dimensions. All unit sizes have discharge openings for both horizontal and downflow configurations, and are factory shipped with all downflow duct openings covered. The unit may be installed either on a rooftop or on a ground-level cement slab. (See Fig. 4 for roof curb dimensions.)

RECEIVING AND INSTALLATION

Step 1 — Check Equipment

IDENTIFY UNIT

The unit model number and serial number are printed on the unit informative plate. Check this information against shipping papers.

INSPECT SHIPMENT

Inspect for shipping damage before removing packaging materials. If unit appears to be damaged or is torn loose from its anchorage, have it examined by transportation inspectors before removal. Forward claim papers directly to transportation company. Manufacturer is not responsible for any damage incurred in transit. Check all items against shipping list. Immediately notify the nearest equipment distribution office if any item is missing. To prevent loss or damage, leave all parts in original packages until installation.

If the unit is to be mounted on a curb in a downflow application, review Step 7 to determine which method is to be used to remove the downflow panels before rigging and lifting into place. The panel removal process may require the unit to be on the ground.

Step 2 — Provide Unit Support

IMPORTANT: The unit must be secured to the curb by installing screws through the bottom of the curb flange and into the unit base rails. When installing large base units onto the common curb, the screws must be installed before allowing the full weight of the unit to rest on the curb. A minimum of six screws are required for large base units. Failure to secure unit properly could result in an unstable unit. See Warning near Rigging/Lifting information and accessory curb instructions for more details.

For hurricane tie downs, contact distributor for details and PE (Professional Engineering) Certificate if required.

ROOF CURB

Install accessory roof curb in accordance with instructions shipped with curb (See Fig. 4). Install insulation, cant strips, roofing, and flashing. Ductwork must be attached to curb.

IMPORTANT: The gasketing of the unit to the roof curb is critical for a water tight seal. Install gasketing material supplied with the roof curb. Improperly applied gasketing also can result in air leaks and poor unit performance.

Curb should be level to within 1/4 in. (6.35 mm) (See Fig 6). This is necessary for unit drain to function properly. Refer to accessory roof curb installation instructions for additional information as required.

Installation on older “G” series roof curbs.

Two accessory kits are available to aid in installing a new “G” series unit on an old “G” roof curb.

1. Accessory kit number CPADCURB001A00, (small chassis) and accessory kit number CPADCURB002A00, (large chassis) includes roof curb adapter and gaskets for the perimeter seal and duct openings. No additional modifications to the curb are required when using this kit.
2. An alternative to the adapter curb is to modify the existing curb by removing the outer horizontal flange and use accessory kit number CPGSKTKIT001A00 which includes spacer blocks (for easy alignment to existing curb) and gaskets for the perimeter seal and duct openings. This kit is used when existing curb is modified by removing outer horizontal flange.

⚠ CAUTION

UNIT/STRUCTURAL DAMAGE HAZARD

Failure to follow this caution may result in property damage.

Ensure there is sufficient clearance for saw blade when cutting the outer horizontal flange of the roof curb so there is no damage to the roof or flashing.

SLAB MOUNT

Place the unit on a solid, level pad that is at least 2 in. (51 mm) above grade. The pad should extend approximately 2 in. (51 mm) beyond the casing on all 4 sides of the unit (See Fig. 7). Do not secure the unit to the pad *except* when required by local codes.

UNIT	ELECTRICAL CHARACTERISTICS	UNIT WT.			UNIT HEIGHT IN/MM			CENTER OF GRAVITY IN/MM			
		LB	KG	"A"	X	Y	Z				
50VR-C24---30*	208/230-1-60	338	153.3	51-3/4	1315	20-1/2	520.7	15-3/4	400.1	23.0	584.2
50VR-C30---30*	208/230-1-60	384	174.2	51-3/4	1315	20-1/2	520.7	15-3/4	400.1	23.0	584.2
50VR-C30---50*	208/230-3-60	384	174.2	51-3/4	1315	20-1/2	520.7	15-3/4	400.1	23.0	584.2

UNIT	CORNER WEIGHT LB/KG			
	VOLTAGE	"1"	"2"	"3"
50VR-C24---30*	208/230	47.3	21.5	60.8
50VR-C30---30*	208/230	53.8	24.4	69.1
50VR-C30---50*	208/230	53.8	24.4	69.1

NOTE: 1. ALL TABLE DATA RELEVANT FOR ALL FACTORY INSTALLED OPTIONS EXCEPT ECONOMIZER.
2. * - INDICATES ALL FOP CODES FOR THE MODELS LISTED.

REQUIRED CLEARANCES TO COMBUSTIBLE MATL.

	INCHES (MM)
TOP OF UNIT.....	14 (355.6)
DUCT SIDE OF UNIT.....	2 (50.8)
SIDE OPPOSITE DUCTS.....	14 (355.6)
BOTTOM OF UNIT.....	0 (0.0)
ELECTRICAL PANEL.....	36 (914.4)

NEC. REQUIRED CLEARANCES.

	INCHES (MM)
BETWEEN UNITS, POWER ENTRY SIDE.....	42 (1066.8)
UNIT AND UNGROUNDED SURFACES, POWER ENTRY SIDE.....	36 (914.0)
UNIT AND BLOCK OR CONCRETE WALLS AND OTHER GROUNDED SURFACES, POWER ENTRY SIDE.....	42 (1066.8)

REQUIRED CLEARANCE FOR OPERATION AND SERVICING

	INCHES (MM)
EVAP. COIL ACCESS SIDE.....	36 (914.0)
POWER ENTRY SIDE.....	42 (1066.8)
(EXCEPT FOR NEC REQUIREMENTS)	
UNIT TOP.....	48 (1219.2)
SIDE OPPOSITE DUCTS.....	36 (914.0)
DUCT PANEL.....	12 (304.8)

*MINIMUM DISTANCES: IF UNIT IS PLACED LESS THAN 12 (304.8) FROM WALL SYSTEM, THEN SYSTEM PERFORMANCE MAYBE COMPROMISED.

DIMENSIONS IN () ARE IN MILLIMETERS

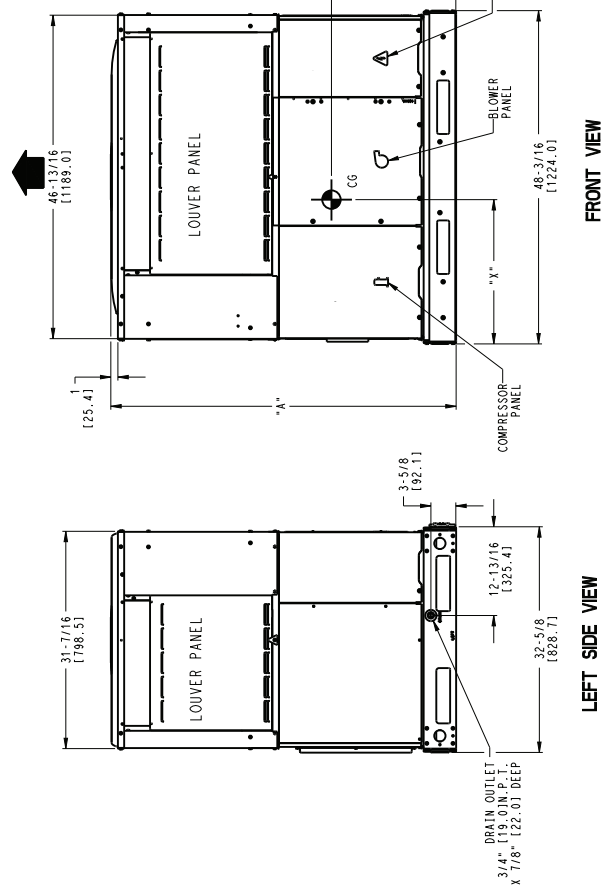
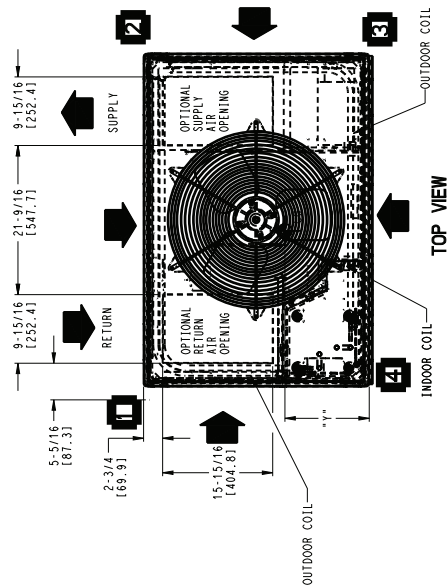

50VR500267 A

50VR

Fig. 2 - 50VR-C24-30 Unit Dimensions

50VR

UNIT	ELECTRICAL CHARACTERISTICS	UNIT WT.		UNIT HEIGHT IN/MM				CENTER OF GRAVITY IN/MM			
		LB	KG	"A"	"X"	"Y"	"Z"	"A"	"X"	"Y"	"Z"
50VR-A36---(3/5/6/0)*	208/230-1, 208/230-3-60, 460-3	413	187.3	44-3/4	20-1/4	514.4	17-1/2	444.5	17-5/8	447.7	
50VR-A42---(3/5/6/0)*	208/230-1, 208/230-3-60, 460-3	444	201.4	50-3/4	20-1/4	514.4	17-1/2	444.5	17-5/8	447.7	
50VR-A48---(3/5/6/0)*	208/230-1, 208/230-3-60, 460-3	447	202.8	48-3/4	20-1/4	514.4	17-1/2	444.5	17-5/8	447.7	
50VR-A60---(3/5/6/0)*	208/230-1, 208/230-3-60, 460-3	503	228.2	54-3/4	20-1/4	514.4	17-1/2	444.5	18	457.2	

UNIT	VOLTAGE	CORNER WEIGHTS LB/KG			
		"1"	"2"	"3"	"4"
50VR-A36---(3/5/6/0)*	208/230/460	49.6	128.1	66.1	37.5
50VR-A42---(3/5/6/0)*	208/230/460	53.3	30.2	71.0	40.3
50VR-A48---(3/5/6/0)*	208/230/460	53.6	30.4	71.5	40.6
50VR-A60---(3/5/6/0)*	208/230/460	60.4	34.2	80.5	45.6

NOTE: 1. ALL TABLE DATA RELEVANT FOR ALL FACTORY INSTALLED OPTIONS EXCEPT ECONOMIZER.
 2. * - INDICATES ALL FPO CODES FOR THE MODELS LISTED.

REQUIRED CLEARANCES TO COMBUSTIBLE MATL.

TOP OF UNIT.....	14	[355.6]
DUCT SIDE OF UNIT.....	2	[50.8]
SIDE OPPOSITE DUCTS.....	14	[355.6]
BOTTOM OF UNIT.....	0	[0.0]
ELECTRICAL PANEL.....	36	[914.4]

NEC. REQUIRED CLEARANCES.

BETWEEN UNITS, POWER ENTRY SIDE.....	42	[1066.8]
UNIT AND UNGROUNDED SURFACES, POWER ENTRY SIDE.....	36	[914.0]
UNIT AND BLOCK OR CONCRETE WALLS AND OTHER GROUNDED SURFACES, POWER ENTRY SIDE.....	42	[1066.8]

REQUIRED CLEARANCE FOR OPERATION AND SERVICING

EVAP. COIL ACCESS SIDE.....	36	[914.0]
POWER ENTRY SIDE.....	42	[1066.8]
(EXCEPT FOR NEC REQUIREMENTS)		
UNIT TOP.....	48	[1219.2]
SIDE OPPOSITE DUCTS.....	36	[914.0]
DUCT PANEL.....	12	[304.8]

*MINIMUM DISTANCES: IF UNIT IS PLACED LESS THAN 12 [304.8] FROM WALL SYSTEM, THEN SYSTEM PERFORMANCE MAYBE COMPROMISED. DIMENSIONS IN [] ARE IN MM.

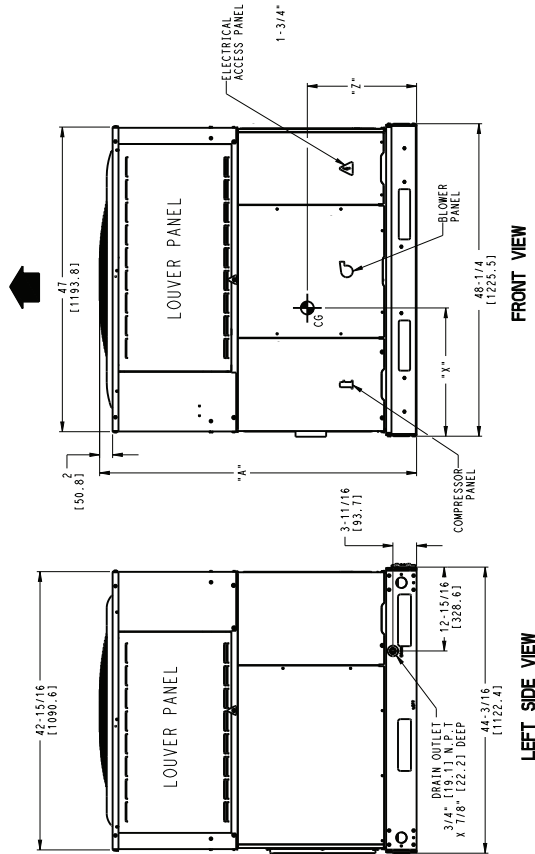
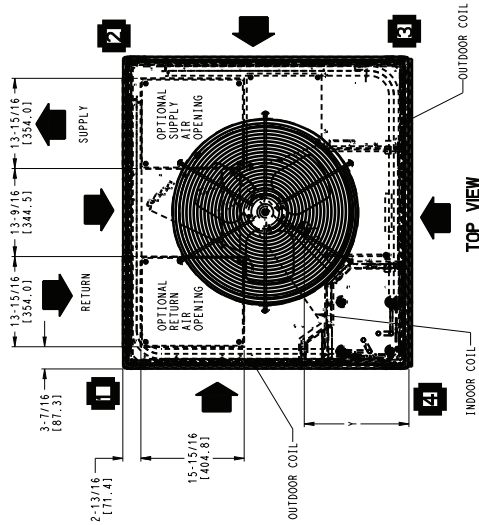

REAR VIEW

50VR500141 A

Fig. 3 - 50VR-A36-60 Unit Dimensions

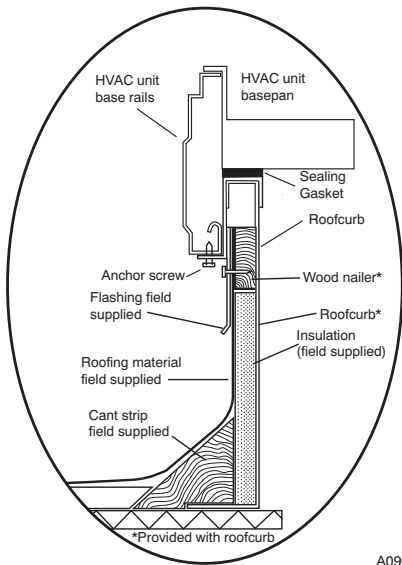

A09090

ROOF CURB DETAIL

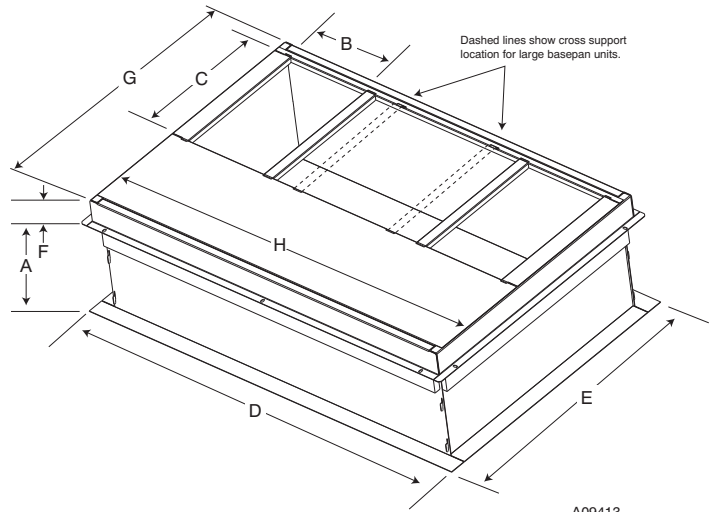

A09413

SMALL/COMMON CURB

50VR

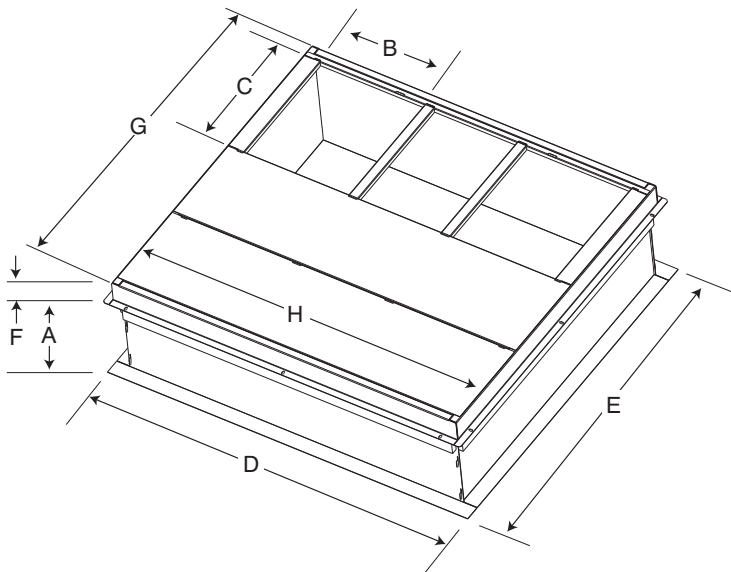

A09415

LARGE CURB

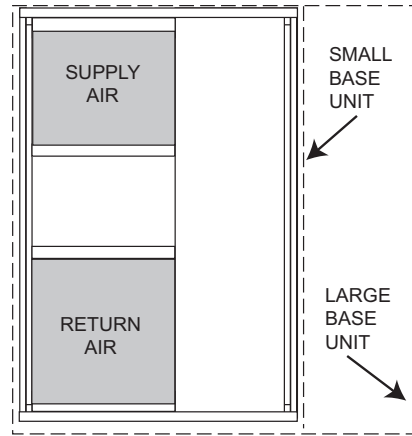

A09094

UNIT PLACEMENT ON COMMON CURB

SMALL OR LARGE BASE UNIT

A09414

UNIT SIZE	CATALOG NUMBER	A IN. (mm)	B (small/common base) IN. (mm)*	B (large base) IN. (mm)*	C IN. (mm)	D IN. (mm)	E IN. (mm)	F IN. (mm)	G IN. (mm)	H IN. (mm)
Small or Large	CPRFCURB011A00	14 (356)	10 (254)	14 (356)	16 (406)	47.8 (1214)	32.4 (822)	2.7 (69)	30.6 (778)	46.1 (1170)
Large	CPRFCURB013A00	14 (356)	14 (356)				43.9 (1116)			

* Part Number CPRFCURB011A00 can be used on both small and large basepan units. The cross supports must be located based on whether the unit is a small basepan or a large basepan.

NOTES:

1. Roof curb must be set up for unit being installed.
2. Seal strip must be applied, as required, to unit being installed.
3. Roof curb is made of 16-gauge steel.
4. Attach ductwork to curb (flanges of duct rest on curb).
5. Insulated panels: 1-in. (25.4 mm) thick fiberglass 1 lb. density.

Fig. 4 - Roof Curb Dimensions

⚠ CAUTION - NOTICE TO RIGGERS ⚠ PRUDENCE - AVIS AUX MANIPULATEUR

ACCESS PANELS MUST BE IN PLACE WHEN RIGGING.
PANNEAUX D'ACCES DOIT ÊTRE EN PLACE POUR MANIPULATION.

Use top skid as spreader bar. / Utiliser la palette du haut comme barre de répartition

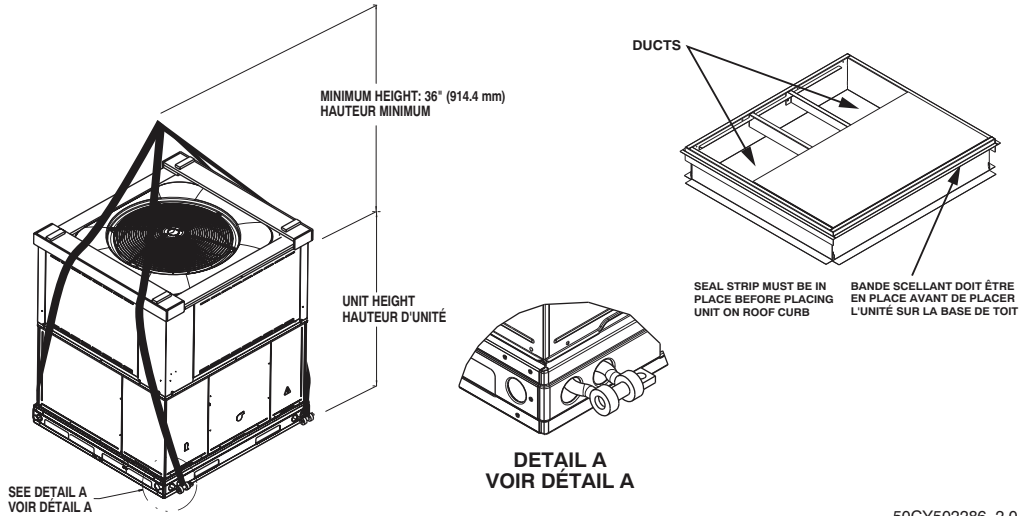

50CY502286 2.0

A09051

Standard Copper Tube Aluminum Fin

SMALL CABINET					LARGE CABINET								
Unit*	24		30		Unit*	36		42		48		60	
	lb	kg	lb	kg		lb	kg	lb	kg	lb	kg	lb	kg
Rigging Weight	347	157	393	178	Rigging Weight	420	191	466	212	462	210	511	232

NOTE: See dimensional drawing for corner weights.

Fig. 5 - Unit Suggested Rigging

Step 3 — Provide Clearances

The required minimum service clearances are shown in Fig. 2 and 3. Adequate ventilation and outdoor air must be provided. The outdoor fan draws air through the outdoor coil and discharges it through the top fan grille. Be sure that the fan discharge does not recirculate to the outdoor coil. Do not locate the unit in either a corner or under an overhead obstruction. The minimum clearance under a partial overhang (such as a normal house overhang) is 48 in. (1219 mm) above the unit top. The maximum horizontal extension of a partial overhang must not exceed 48 in. (1219 mm)

IMPORTANT: Do not restrict outdoor airflow. An air restriction at either the outdoor-air inlet or the fan discharge may be detrimental to compressor life.

Do not place the unit where water, ice, or snow from an overhang or roof will damage or flood the unit. Do not install the unit on carpeting or other combustible materials. Slab-mounted units should be at least 2 in. (51 mm) above the highest expected water and runoff levels. Do not use unit if it has been under water.

Step 4 — Field-Fabricate Ductwork

Secure all ducts to roof curb and building structure on vertical discharge units. Do not connect ductwork to unit. For horizontal applications, unit is provided with flanges on the horizontal openings. All ductwork should be secured to the flanges. Insulate and weatherproof all external ductwork, joints, and roof openings with counter flashing and mastic in accordance with applicable codes.

Ducts passing through an unconditioned space must be insulated and covered with a vapor barrier. If a plenum return is used on a vertical unit, the return should be ducted through the roof deck to comply with applicable fire codes. See unit rating plate for any

required clearances around ductwork. Cabinet return-air static shall not exceed -.25 IN. W.C.

Step 5 — Rig and Place Unit

Rigging and handling of this equipment can be hazardous for many reasons due to the installation location (roofs, elevated structures, etc.).

Only trained, qualified crane operators and ground support staff should handle and install this equipment.

When working with this equipment, observe precautions in the literature, on tags, stickers, and labels attached to the equipment, and any other safety precautions that might apply.

Training for operators of the lifting equipment should include, but not be limited to, the following:

1. Application of the lifter to the load, and adjustment of the lifts to adapt to various sizes or kinds of loads.
2. Instruction in any special operation or precaution.
3. Condition of the load as it relates to operation of the lifting kit, such as balance, temperature, etc.

Follow all applicable safety codes. Wear safety shoes and work gloves.

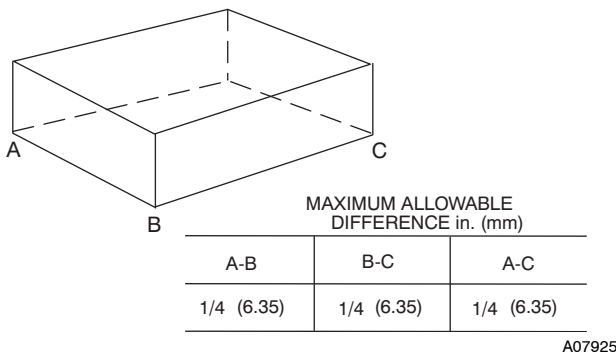

Fig. 6 - Unit Leveling Tolerances

INSPECTION

Prior to initial use, and at monthly intervals, all rigging shackles, clevis pins, and straps should be visually inspected for any damage, evidence of wear, structural deformation, or cracks. Particular attention should be paid to excessive wear at hoist hooking points and load support areas. Materials showing any kind of wear in these areas must not be used and should be discarded.

⚠ WARNING

UNIT FALLING HAZARD

Failure to follow this warning could result in personal injury or death.

Never stand beneath rigged units or lift over people.

1. Leave top shipping skid on the unit for use as a spreader bar to prevent the rigging straps from damaging the unit. If the skid is not available, use a spreader bar of sufficient length to protect the unit from damage.

⚠ WARNING

PROPERTY DAMAGE HAZARD

Failure to follow this warning could result in personal injury.

When straps are taut, the clevis should be a minimum of 36 in. (914 mm) above the unit top cover.

Rigging/Lifting of Unit (See Fig. 5)

⚠ WARNING

UNIT FALLING HAZARD

Failure to follow this warning could result in personal injury or death.

Large base units must be secured to common curb before allowing full weight of unit to rest on curb. Install screws through curb into unit base rails while rigging crane is still supporting unit.

Lifting holes are provided in base rails as shown.

1. Attach shackles, clevis pins, and straps to the base rails of the unit. Be sure materials are rated to hold the weight of the unit (See Fig. 5).
2. Attach a clevis of sufficient strength in the middle of the straps. Adjust the clevis location to ensure unit is lifted level with the ground.

After the unit is placed on the roof curb or mounting pad, remove the top skid.

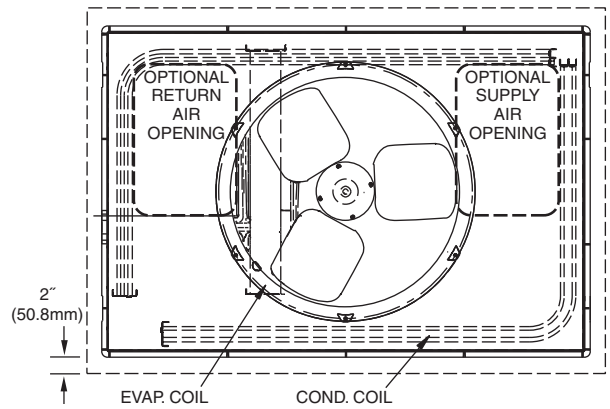

Fig. 7 - Slab Mounting Detail

Step 6 — Connect Condensate Drain

NOTE: When installing condensate drain connection be sure to comply with local codes and restrictions.

This unit disposes of condensate water through a 3/4 in. NPT fitting which exits through the base on the evaporator coil access side. See Fig. 2 and 3 for location.

Condensate water can be drained directly onto the roof in rooftop installations (where permitted) or onto a gravel apron in ground level installations. Install a field-supplied 2-in. (51 mm) condensate trap at end of condensate connection to ensure proper drainage. Make sure that the outlet of the trap is at least 1 in. (25 mm) lower than the drain pan condensate connection to prevent the pan from overflowing (See Fig. 8). When using a gravel apron, make sure it slopes away from the unit.

Connect a drain tube using a minimum of 3/4 in. PVC or 3/4 in. copper pipe (all field-supplied) at the outlet end of the 2-in. (51 mm) trap. Do not undersize the tube. Pitch the drain tube downward at a slope of at least 1-in. (25 mm) for every 10 ft (3.1 m) of horizontal run. Be sure to check the drain tube for leaks. Prime trap at the beginning of the cooling season start-up.

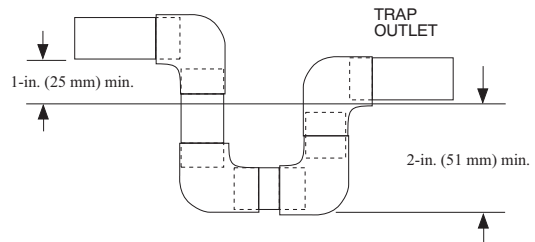

Fig. 8 - Condensate Trap

Step 7 — Install Duct Connections

The design and installation of the duct system must be in accordance with the standards of the NFPA for installation of non-residence type air conditioning and ventilating systems, NFPA 90A or residence type, NFPA 90B and/or local codes and ordinances.

Select and size ductwork, supply-air registers, and return air grilles according to ASHRAE (American Society of Heating, Refrigeration, and Air Conditioning Engineers) recommendations. The unit has duct flanges on the supply- and return-air openings on the side of the unit.

When designing and installing ductwork, consider the following:

1. All units should have field-supplied filters or accessory filter rack installed in the return-air side of the unit. Recommended sizes for filters are shown in Table 1.
2. Avoid abrupt duct size increases and reductions. Abrupt change in duct size adversely affects air performance.

IMPORTANT: Use flexible connectors between ductwork and unit to prevent transmission of vibration. Use suitable gaskets to

50VR

ensure weather-tight and airtight seal. When electric heat is installed, use fireproof canvas (or similar heat resistant material) connector between ductwork and unit discharge connection. If flexible duct is used, insert a sheet metal sleeve inside duct. Heat resistant duct connector (or sheet metal sleeve) must extend 24-in. (610 mm) from electric heater element.

3. Size ductwork for cooling air quantity (cfm). The minimum air quantity for proper electric heater operation is listed in Table 2. Heater limit switches may trip at air quantities below those recommended.
4. Seal, insulate, and weatherproof all external ductwork. Seal, insulate and cover with a vapor barrier all ductwork passing through conditioned spaces. Follow latest Sheet Metal and Air Conditioning Contractors National Association (SMACNA) and Air Conditioning Contractors Association (ACCA) minimum installation standards for residential heating and air conditioning systems.
5. Secure all ducts to building structure. Flash, weatherproof, and vibration-isolate duct openings in wall or roof according to good construction practices.

CONFIGURING UNITS FOR DOWNFLOW (VERTICAL) DISCHARGE

50VR

⚠ WARNING

ELECTRICAL SHOCK HAZARD

Failure to follow this warning could result in personal injury or death.

Before performing service or maintenance operations on the system, turn off main power to unit and install lockout tag. There may be more than one disconnect switch.

1. Open all electrical disconnects and install lockout tag before starting any service work.
2. Remove horizontal (metal) ductcovers to access vertical (downflow) discharge duct knockouts in unit basepan. (See Fig. 9.)

To remove downflow return and supply knockout covers, break front and right side connecting tabs with a screwdriver and hammer. Push cover down to break rear and left side tabs.

NOTE: These panels are held in place with tabs similar to an electrical knockout. Reinstall horizontal duct covers (Fig. 9) shipped on unit from factory. Insure openings are air and watertight.

NOTE: The design and installation of the duct system must be in accordance with the standards of the NFPA for installation of nonresidence-type air conditioning and ventilating systems, NFPA 90A or residence-type, NFPA 90B; and/or local codes and ordinances.

Adhere to the following criteria when selecting, sizing, and installing the duct system:

1. Units are shipped for side shot installation.
2. Select and size ductwork, supply-air registers, and return-air grilles according to American Society of Heating, Refrigeration and Air Conditioning Engineers (ASHRAE) recommendations.
3. Use flexible transition between rigid ductwork and unit to prevent transmission of vibration. The transition may be screwed or bolted to duct flanges. Use suitable gaskets to ensure weather-tight and airtight seal.
4. All units must have field-supplied filters or accessory filter rack installed in the return-air side of the unit. Recommended sizes for filters are shown in Table 1.
5. Size all ductwork for maximum required airflow (either heating or cooling) for unit being installed. Avoid abrupt

duct size increases or decreases or performance may be affected.

6. Adequately insulate and weatherproof all ductwork located outdoors. Insulate ducts passing through unconditioned space, and use vapor barrier in accordance with latest issue of Sheet Metal and Air Conditioning Contractors National Association (SMACNA) and Air Conditioning Contractors of America (ACCA) minimum installation standards for heating and air conditioning systems. Secure all ducts to building structure.
7. Flash, weatherproof, and vibration-isolate all openings in building structure in accordance with local codes and good building practices.

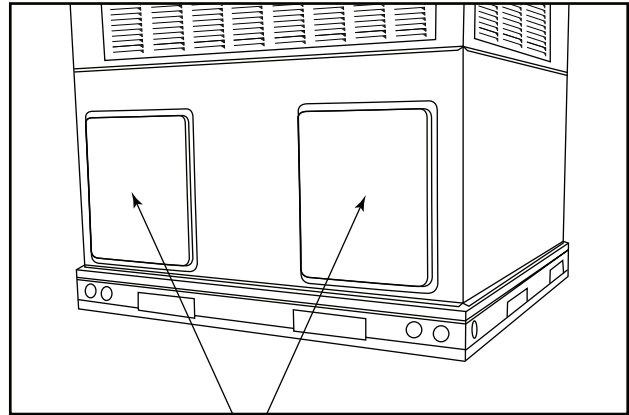

Horizontal Duct Covers

A09076

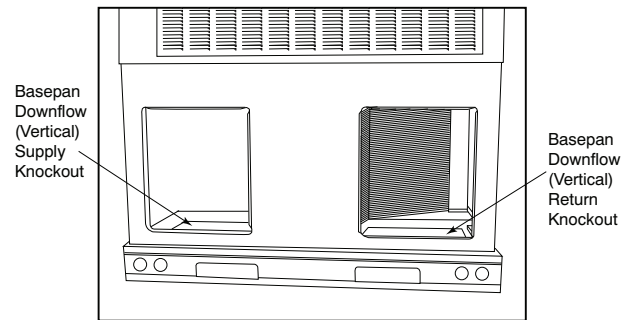

A09093

Fig. 9 - Supply and Return Duct Opening

Step 8 — Install Electrical Connections

⚠ WARNING

ELECTRICAL SHOCK HAZARD

Failure to follow this warning could result in personal injury or death.

The unit cabinet must have an uninterrupted, unbroken electrical ground to minimize the possibility of personal injury if an electrical fault should occur. This ground may consist of an electrical wire connected to the unit ground screw in the control compartment, or conduit approved for electrical ground when installed in accordance with NFPA 70 (NEC) (latest edition) (in Canada, Canadian Electrical Code CSA C22.1) and local electrical codes.

⚠ CAUTION

UNIT COMPONENT DAMAGE HAZARD

Failure to follow this caution may result in damage to the unit being installed.

1. Make all electrical connections in accordance with NFPA 70 (NEC) (latest edition) and local electrical codes governing such wiring. In Canada, all electrical connections must be in accordance with CSA standard C22.1 Canadian Electrical Code Part 1 and applicable local codes. Refer to unit wiring diagram.
2. Use only copper conductor for connections between field-supplied electrical disconnect switch and unit. **DO NOT USE ALUMINUM WIRE.**
3. Be sure that high-voltage power to unit is within operating voltage range indicated on unit rating plate. On 3-phase units, ensure phases are balanced within 2 percent. Consult local power company for correction of improper voltage and/or phase imbalance.
4. Do not damage internal components when drilling through any panel to mount electrical hardware, conduit, etc.

HIGH-VOLTAGE CONNECTIONS

The unit must have a separate electrical service with a field-supplied, waterproof disconnect switch mounted at, or within sight from the unit. Refer to the unit rating plate, NEC and local codes for maximum fuse/circuit breaker size and minimum circuit amps (ampacity) for wire sizing.

The field-supplied disconnect may be mounted on the unit over the high-voltage inlet hole when the standard power and low-voltage entry points are used. See Fig. 2 and 3 for acceptable location.

See unit wiring label (Fig. 15, 17 and 18) and Fig. 10 for reference when making high voltage connections. Proceed as follows to complete the high-voltage connections to the unit.

Single phase units:

1. Run the high-voltage (L1, L2) and ground lead into the control box.
2. Connect ground lead to chassis ground connection.
3. Locate the black and yellow wires connected to the line side of the contactor.
4. Connect field L1 to black wire from connection 11 of the compressor contactor.
5. Connect field wire L2 to yellow wire from connection 23 of the compressor contactor.

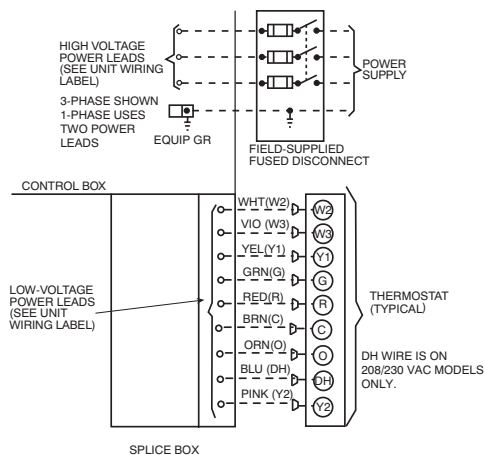

Fig. 10 - High- and Control-Voltage Connections

A13176

Three-phase units:

1. Run the high-voltage (L1, L2, L3) and ground lead into the control box.
2. Connect ground lead to chassis ground connection.
3. Locate the black and yellow wires connected to the line side of the contactor.
4. Connect field L1 to black wire from connection 11 of the compressor contactor.
5. Connect field wire L3 to yellow wire from connection 13 of the compressor contactor.
6. Connect field wire L2 to blue wire from compressor.

SPECIAL PROCEDURES FOR 208-V OPERATION

⚠ WARNING

ELECTRICAL SHOCK HAZARD

Failure to follow this warning could result in personal injury or death.

Before installing or servicing system, always turn off main power to system and install lockout tag. With disconnect switch open, move black wire from transformer (3/16 in.)(4.8 mm) terminal marked 230 to terminal marked 208. This retaps transformer to primary voltage of 208 vac.

50VR

CONTROL VOLTAGE CONNECTIONS

NOTE: Do not use any type of power-stealing thermostat. Unit control problems may result.

Use no. 18 American Wire Gage (AWG) color-coded, insulated (35°C minimum) wires to make the control voltage connections between the thermostat and the unit. If the thermostat is located more than 100 ft (30.5 m) from the unit (as measured along the control voltage wires), use no. 16 AWG color-coded, insulated (35° C minimum) wires.

STANDARD CONNECTION

Locate the nine low voltage thermostat leads (eight for 460 VAC models) in 24 volt splice box. See Fig. 10 for connection diagram. Run the low-voltage leads from the thermostat, through the control wiring inlet hole grommet (Fig. 2 and 3), and into the low-voltage splice box. Provide a drip loop before running wires through panel. Secure and strain relief all wires so that they do not interfere with operation of unit.

If an accessory electric heater is installed, low voltage leads from heater must be connected to factory supplied control leads from Indoor Fan Board P4 connector.

NOTE: If the unit 24V wires do not have a matching receptacle, cut the 24V wires from the electric heater plug, strip the ends, and wire nut together to match the schematic connections. If the electric heater 24V wires do not have a matching plug, cut the 24V wires from the unit receptacle, strip the ends, and wire nut together to match the schematic connections.

Factory wires are provided for electric heat staging W1 and W2 (W2 and W3 on IFB). If room thermostat has only one stage of supplemental heat, connect white and violet wires shown in Fig. 10 to second stage heat field wire.

Some electric heaters have four control wires (plus common wire). Consult unit wiring diagram and electric heater wiring diagram for additional details.

TRANSFORMER PROTECTION

The transformer is of the energy-limiting type, however a direct short will likely blow a secondary fuse. If an overload or short is present, correct overload condition and check for blower fuse on Indoor Fan Board. Replace fuse as required with correct size and rating.

Table 1 – Physical Data-Unit 50VR

UNIT SIZE	24	30	36	42	48	60
NOMINAL CAPACITY (ton)	2	2-1/2	3	3-1/2	4	5
SHIPPING WEIGHT lb.	347	393	420	466	462	511
SHIPPING WEIGHT (kg)	157	178	191	212	210	232
COMPRESSORS	Scroll					
Quantity	1					
REFRIGERANT (R-410A)						
Quantity lb	8.2	11.2	11.0	14.6	12.0	14.8
Quantity (kg)	3.7	5.1	5.0	6.6	5.4	6.7
REFRIGERANT METERING DEVICE	TXV, Indoor TXV					
ORIFICE						
ID (in.)	.032 (2)	.035 (1) .038 (1)	.042 (2)	.042 (2)	.042 (2)	.052 (2)
ID (mm)	0.81 (2)	.89 (1) .97 (1)	1.07 (2)	1.07 (2)	1.07 (2)	1.32 (2)
OUTDOOR COIL						
Rows...Fins/in.	1...21	2...21	2...21	2...21	2...21	2...21
Face Area (sq ft)	18.8	18.8	13.6	19.4	17.5	23.3
OUTDOOR FAN						
Nominal Cfm	2100	2500	3000	3000	3300	3600
Diameter in.	24	24	26	26	26	26
Diameter (mm)	609.6	609.6	660.4	660.4	660.4	660.4
Motor Hp (Rpm)	1/12 (800)	1/8 (810)	1/5 (810)	1/5 (810)	1/5 (810)	1/5 (810)
INDOOR COIL						
Rows...Fins/in.	3...17	3...17	3...17	3...17	3...17	4...17
Face Area (sq ft)	3.7	3.7	4.7	4.7	5.7	5.7
INDOOR BLOWER						
Nominal Low Stage Cooling Airflow (Cfm)	675	775	900	1050	1200	1400
Nominal High Stage Cooling Airflow (Cfm)	855	1000	1200	1400	1600	1750
Size in.	10x10	10x10	11x10	11x10	11x10	11x10
Size (mm.)	254x254	254x254	279.4x254	279.4x254	279.4x254	279.4x254
Motor HP (RPM)	1/2 (1050)	1/2 (1050)	3/4 (1000)	3/4 (1075)	1.0 (1075)	1.0 (1075)
HIGH-PRESSURE SWITCH (psig) Cut-out Reset (Auto)	650 +/- 15 420 +/- 25					
LOW-PRESSURE SWITCH (psig) cut-out Reset (auto)	20 +/- 5 45 +/- 5					
RETURN-AIR FILTERS†‡						
Throwaway Size in.	20x20x1	20x24x1	24x30x1		24x36x1	
Throwaway Size (mm)	508x508x25	508x610x25	610x762x25		610x914x25	

† Required filter sizes shown are based on the larger of the AHRI (Air Conditioning Heating and Refrigeration Institute) rated cooling airflow or the heating airflow velocity of 300 ft/minute for throwaway type or 450 ft/minute for high-capacity type. Air filter pressure drop for non-standard filters must not exceed 0.08 in. W.C.

‡ If using accessory filter rack refer to the filter rack installation instructions for correct filter sizes and quantity.

Table 2 – Minimum Airflow for Safe Electric Heater Operation (CFM)

SIZE	24	30	36	42	48	60
Cfm	850	1000	1200	1400	1600	1750

50VR

PRE-START-UP



WARNING

ENVIRONMENTAL, FIRE, EXPLOSION, ELECTRICAL SHOCK HAZARD

Failure to follow this warning could result in personal injury or death and/or property damage.

1. Follow recognized safety practices and wear protective goggles when checking or servicing refrigerant system.
2. Relieve and recover all refrigerant from system before touching or disturbing compressor plug if refrigerant leak is suspected around compressor terminals.
3. Never attempt to repair soldered connection while refrigerant system is under pressure.
4. Do not use torch to remove any component. System contains oil and refrigerant under pressure.
5. To remove a component, wear protective goggles and proceed as follows:
 - a. Shut off electrical power to unit and install lockout tag.
 - b. Relieve and reclaim all refrigerant from system using both high- and low-pressure ports.
 - c. Cut component connecting tubing with tubing cutter and remove component from unit.
 - d. Carefully unsweat remaining tubing stubs when necessary. Oil can ignite when exposed to torch flame.

Use the Start-Up Checklist supplied at the end of this book and proceed as follows to inspect and prepare the unit for initial start-up:

1. Remove all access panels (see Fig. 21).
2. Read and follow instructions on all DANGER, WARNING, CAUTION, and INFORMATION labels attached to, or shipped with unit.
3. Make the following inspections:
 - a. Inspect for shipping and handling damages, such as broken lines, loose parts, disconnected wires, etc.
 - b. Inspect for oil at all refrigerant tubing connections and on unit base. Detecting oil generally indicates a refrigerant leak. Leak test all refrigerant tubing connections using electronic leak detector, or liquid-soap solution. If a refrigerant leak is detected, see following **Check for Refrigerant Leaks** section.
 - c. Inspect all field- and factory-wiring connections. Be sure that connections are completed and tight. Ensure wires do not touch refrigerant tubing or sharp sheet metal edges.
 - d. Inspect coil fins. If damaged during shipping and handling, carefully straighten fins with a fin comb.
4. Verify the following conditions:
 - a. Make sure that outdoor-fan blade is correctly positioned in fan orifice.
 - b. Make sure that air filter(s) is in place.
 - c. Make sure that condensate drain pan and trap are filled with water to ensure proper drainage.
 - d. Make sure that all tools and miscellaneous loose parts have been removed
5. Each unit system has two (2) Schrader-type ports, one low-side Schrader fitting located on the suction line, and one high-side Schrader fitting located on the compressor discharge line. Be sure that caps on the ports are tight.

START-UP

Step 1 — Check Cooling and Heating Control Operation

Start and check the unit for proper control operation as follows:

1. Place room thermostat SYSTEM switch or MODE control in OFF position. Observe that blower motor starts when FAN mode is placed in FAN ON position and shuts down when FAN MODE switch is placed in AUTO position.
2. Thermostat:

On a typical two stage thermostat, when the room temperature rises 1 or 2 degrees above the cooling control setting of the thermostat, the thermostat completes the circuit between thermostat terminal R and terminals Y1, and G. These completed circuits through the thermostat connect the contactor coil (C) (through unit wire Y1) and indoor fan board (through unit wire G) across the 24-v. secondary of transformer (TRAN).

On a typical two stage thermostat, when the room temperature is several degrees above the cooling control setting of the thermostat, the thermostat completes the circuit between terminal R and terminals Y1, Y2, and G.
3. If your unit contains accessory electric heat, place system switch or MODE control in HEAT position. Set control above room temperature. Observe that the indoor blower is operating and warm air is flowing through the supply air vents inside your home. Observe that the heating cycle shuts down when the control setting is satisfied.

If your unit does not contain accessory electric heat and you would like to obtain it, please contact your local dealer for more information.
4. When using an automatic changeover room thermostat place both SYSTEM or MODE control and FAN mode switches in AUTO positions. Observe that unit operates in Cooling mode when temperature control is set to “call for Cooling” (below room temperature).

NOTE: Once the compressor has started and then has stopped, it should not be started again until 5 minutes have elapsed.

Step 2 — Check for Refrigerant Leaks



WARNING



EXPLOSION HAZARD

Failure to follow this warning could result in death, serious personal injury, and/or property damage.

Never use air or gases containing oxygen for leak testing or operating refrigerant compressors. Pressurized mixtures of air or gases containing oxygen can lead to an explosion.

Proceed as follows to locate and repair a refrigerant leak and to charge the unit:

1. Locate leak and make sure that refrigerant system pressure has been relieved and reclaimed from both high- and low-pressure ports.
2. Repair leak following Refrigerant Service procedures.

NOTE: Install a filter drier whenever the system has been opened for repair.

3. Add a small charge of R-410A refrigerant vapor to system and leak-test unit.
4. Recover refrigerant from refrigerant system and evacuate to 500 microns if no additional leaks are found.
5. Charge unit with R-410A refrigerant, using an electronic scale. Refer to unit rating plate for required charge.

Step 3 — Start-Up Adjustments

Complete the required procedures given in the Pre-Start-Up section before starting the unit. Do not jumper any safety devices when operating the unit. Do not operate the unit in cooling mode when the outdoor temperature is below 40°F (4°C) (unless accessory low-ambient kit is installed).

IMPORTANT: Three-phase, scroll compressors are direction oriented. Unit must be checked to ensure proper compressor 3-phase power lead orientation. If not corrected within 5 minutes, the internal protector will shut off the compressor. The 3-phase power leads to the unit must be reversed to correct rotation. When turning backwards, the difference between compressor suction and discharge pressures may be near zero.

Checking and Adjusting Refrigerant Charge

50VR

⚠
WARNING

EXPLOSION HAZARD

Failure to follow this warning could result in death, serious personal injury, and/or property damage.

Never use air or gases containing oxygen for leak testing or operating refrigerant compressors. Pressurized mixtures of air or gases containing oxygen can lead to an explosion.

The refrigerant system is fully charged with R-410A refrigerant and is tested and factory sealed.

NOTE: Adjustment of the refrigerant charge is not required unless the unit is suspected of not having the proper R-410A charge.

A subcooling charging chart is attached to the inside of the compressor access panel. The chart includes the required liquid line temperature at given discharge line pressures and outdoor ambient temperatures.

An accurate thermocouple- or thermistor-type thermometer, and a gauge manifold are required when using the subcooling charging method for evaluating the unit charge. Do not use mercury or small dial-type thermometers because they are not adequate for this type of measurement.

NOTE: Allow system to operate on high stage cooling for a minimum of 15 minutes before checking or adjusting refrigerant charge.

IMPORTANT: When evaluating the refrigerant charge, an indicated adjustment to the specified factory charge must always be very minimal. If a substantial adjustment is indicated, an abnormal condition exists somewhere in the cooling system, such as insufficient airflow across either coil or both coils.

1. Remove caps from low- and high-pressure service fittings.
2. Using hoses with valve core depressors, attach low- and high-pressure gauge hoses to low- and high-pressure service fittings, respectively.
3. Start unit and let run until system pressures stabilize.
4. Measure and record the following:
 - a. Outdoor ambient-air temperature (°F [°C] db).
 - b. Liquid line temperature (°F [°C]) at TXV.
 - c. Discharge (high-side) pressure (psig).
 - d. Suction (low-side) pressure (psig) (for reference only).
5. Using Cooling Charging Charts (See Fig. 19) compare outdoor-air temperature (°F [°C] db) with the discharge line

pressure (psig) to determine desired system operating liquid line temperature (See Fig. 19).

6. Compare actual liquid line temperature with desired liquid line temperature. Using a tolerance of ±2°F (±1.1°C), add refrigerant if actual temperature is more than 2°F (1.1°C) higher than proper liquid line temperature, or remove refrigerant if actual temperature is more than 2°F (1.1°C) lower than required liquid line temperature.

NOTE: If the problem causing the inaccurate readings is a refrigerant leak, refer to Check for Refrigerant Leaks section.

Indoor Airflow and Airflow Adjustments

⚠
CAUTION

UNIT OPERATION HAZARD

Failure to follow this caution may result in unit damage.

For cooling operation, the recommended airflow is 350 to 450 cfm for each 12,000 Btuh of rated cooling capacity. For heating operation, the airflow must produce a temperature rise that falls within the range stamped on the unit rating plate.

NOTE: Be sure that all supply-air and return-air grilles are open, free from obstructions, and adjusted properly.

⚠
WARNING

ELECTRICAL SHOCK HAZARD

Failure to follow this warning could result in personal injury or death.

Disconnect electrical power to the unit and install lockout tag before changing blower speed.

This unit has independent fan speeds for low stage cooling and high stage cooling. In addition, 208/230 VAC models have the field-selectable capability to run an enhanced dehumidification ('DEHUM') speed on high stage cooling (as low as 320 CFM per ton). Coupled with the improved dehumidification associated with low stage cooling, the DHUM speed allows for a complete dehumidification solution independent of cooling stage.

Units with the Advanced Dehumidification FIOF feature independent normal and dehumidification fan speeds for low stage cooling and high stage cooling.

Table 3 shows the operation modes and the associated fan speeds with each mode for all models without Advanced Dehumidification:

Table 3 – Operation Modes and Fan Speeds

208/230 VAC Models without Advanced Dehumidification (AD) FIOF

Operation Mode	Fan Speed Tap Connection
Low Stage Cooling/Heat Pump	LOW
High Stage Cooling/Heat Pump	HIGH
High Stage Enhanced Dehumidification Cooling	DH
Continuous Fan	LOW

460 VAC Models

Operation Mode	Fan Speed Tap Connection
Low Stage Cooling/Heat Pump	LOW
High Stage Cooling/Heat Pump	HIGH
Continuous Fan	LOW

⚠ WARNING

ELECTRICAL SHOCK HAZARD

Failure to follow this warning could result in personal injury or death.

Disconnect electrical power to the unit and install lockout tag before changing blower speed.

The standard evaporator fan motor is factory set to provide 5 different fan speeds to choose from for the various operation modes (see Table 4). All models are factory-shipped for nominal high stage and low stage cooling airflow operation at minimum external static pressure. See Table 2.

Table 4 – Color Coding for Indoor Fan Motor Leads

Black = High Speed
Orange = Med-High Speed
Red = Med Speed
Pink = Med-Low Speed
Blue = Low Speed

Selection of Proper Fan Speeds for Operation Modes:

Low Stage Cooling/Heat Pump (All Models without Advanced Dehumidification): Using Tables 8 , 9, and 10, find the external static pressure drops for wet coil, economizer, and filter, and add them to dry coil measured on the system. Using this total static pressure, look up Table 5 to find the airflows available at the total static pressure. For 208/230 VAC models, connect the chosen fan speed wire to “LO COOL” connection on the IFB Board (see Fig. 11). For 460 VAC models, connect the chosen fan speed wire to “LOW” connection on the IFB (see Fig. 11).

High Stage Cooling/Heat Pump (All Models without Advanced Dehumidification): Using Table 8 , 9, and 10, find the external static pressure drops for wet coil, economizer, and filter, and add them to dry coil measured on the system. Using this total static pressure, look up Table 5 to find the airflows available at the total static pressure. The speed chosen must provide airflow of between 350 to 450 CFM per ton of cooling. For 208/230 VAC models, connect the chosen fan speed wire to “HI COOL” connection on the IFB Board (See Fig. 11). For 460 VAC models, connect the chosen fan speed wire to “HIGH” connection on the IFB (see Fig. 11).

High Stage Enhanced Dehumidification Cooling (208/230 VAC Models without Advanced Dehumidification): Using the total static pressure for selecting the high stage cooling speed, look up Table 5 to find lower speed/airflows available at that total static pressure. All airflows highlighted in Table 5 are acceptable for the Dehum speed. The speed chosen must provide airflow of between 320 to 400 CFM per ton of cooling. To activate the high stage enhanced dehumidification cooling mode, the shunt jumper must be moved from the “No DH” to the “DH” selection. (See Fig. 11, close up.) For 208/230 VAC models, connect the chosen fan speed wire to “DHUM” connection on the IFB Board (see Fig. 11).

Continuous Fan (All Models without Advanced Dehumidification): Continuous fan speed is the same speed as Low Stage Cooling.

To activate the high stage enhanced dehumidification cooling mode, the shunt jumper in Fig. 11 must be moved from the No DH to DH selection (See Fig. 11, close up).

Using the Same Fan Speed for More than One Mode: Some fan speeds are ideal for more than one mode of operation. It is permissible to use a field-supplied jumper wire to connect one speed tap wire to two or more speed connections on the Interface Fan Board (IFB). Jumper wires must use 18 AWG wire with at least 2/64” insulation.

Cooling/Heat Pump/Continuous Fan with Advanced Dehumidification: For Advanced Dehumidification models, to

use the dehumidification feature, cut the J1 jumper found on the Interface Fan Board (IFB). (See Fig. 11 and 16.) For proper operation, the dehumidistat must open on humidity rise above the humidity set point. The unit will naturally adapt airflow to the external static pressure drop measured on the system. There is no need to adjust the factory installed taps.

SEQUENCE OF OPERATION

- a. Continuous Fan
 - (1.) Thermostat closes circuit R to G energizing the blower motor for continuous fan. The indoor fan is energized on low speed.
- b. Cooling Mode
 - (1.) Low Stage: Thermostat closes R to G, R to Y1, and R to O. The compressor and indoor fan are energized on low speed. The outdoor fan is also energized
 - (2.) High Stage: Thermostat closes R to G, R to Y1, R to Y2, and R to O. The compressor and indoor fan are energized on high speed. The outdoor fan is also energized.
- c. Electric Heating Mode
 - (1.) Thermostat closes circuit R to W2 or W3, and R to G. There are no on or off delays.
- d. Heat Pump Heating
 - (1.) Low Stage: Thermostat closes R to G, R to Y1. The compressor and indoor fan are energized on low speed. The outdoor fan is also energized
 - (2.) High Stage: Thermostat closes R to G, R to Y1, R to Y2. The compressor and indoor fan are energized on high speed. The outdoor fan is also energized.
- e. Heat Pump Heating with Auxiliary Heat
 - (1.) Thermostat closes circuits R to G, R to Y and R to W/W1 or W2. The compressor, indoor and outdoor fans are energized, as well as the electric heat relays.
- f. Defrost Mode

The defrost mode is automatically energized by the defrost board during heating mode. The defrost board energizes “O” (reversing valve) and “W2” (electric heat). It also de-energizes the outdoor fan. When defrost is complete, unit will return to heating mode. If room thermostat is satisfied during defrost, unit will shut down and restart in defrost on next call for heat.

Step 4 — Defrost Control

Quiet Shift

Quiet Shift is a field-selectable defrost mode, which will eliminate occasional noise that could be heard at the start of defrost cycle and restarting of heating cycle. It is selected by placing DIP switch 3 (on defrost board) in ON position.

When Quiet Shift switch is placed in ON position, and a defrost is initiated, the following sequence of operation will occur. Reversing valve will energize, outdoor fan will turn off, compressor will turn off for 30 sec and then turn back on to complete defrost. At the start of heating after conclusion of defrost reversing valve will de-energize, compressor will turn off for another 30 sec, and the outdoor fan will stay off for 40 sec, before starting in the Heating mode.

Defrost

The defrost control is a time/temperature control which includes a field-selectable time period (DIP switch 1 and 2 on the board) between defrost cycles of 30, 60, 90, or 120 minutes (factory set at 60 minutes). To initiate a forced defrost, two options are available depending on the status of the defrost thermostat.

50VR

50VR

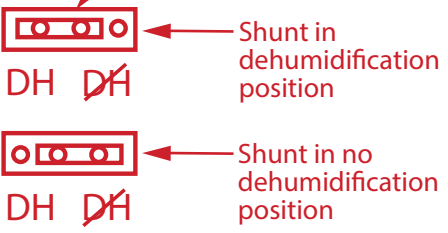
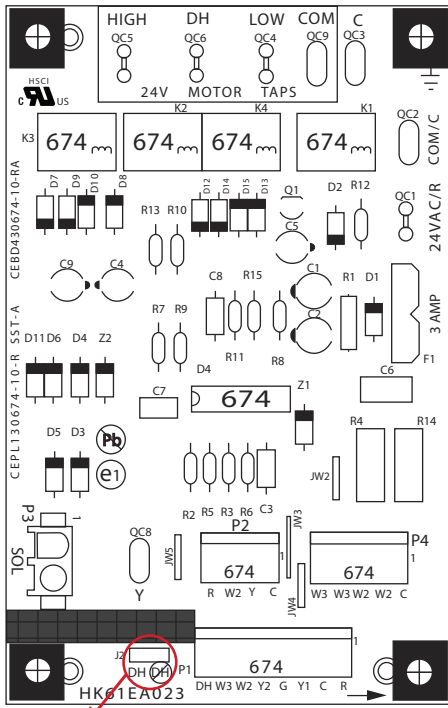

208/230 VAC Models

A12571

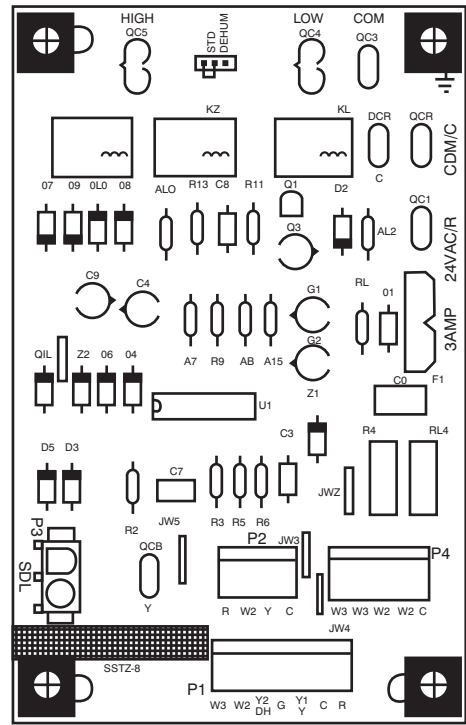

460 VAC Models

A09059

Cut J1 shunt to enable Advanced Dehumidification

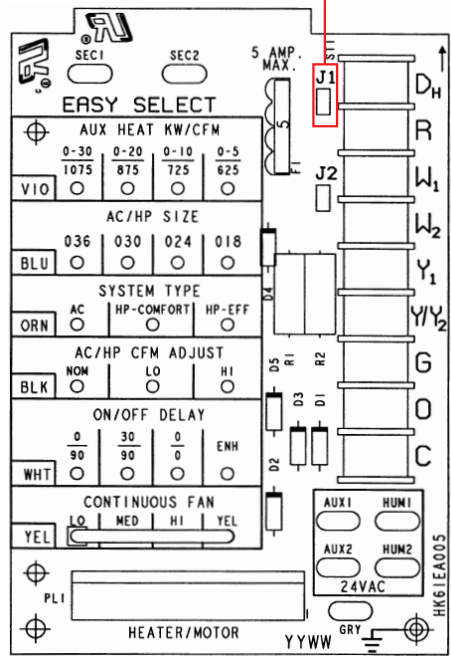

208/230 VAC Advanced Dehumidification Models

A180104

Fig. 11 - Interface Fan Board (IFB)

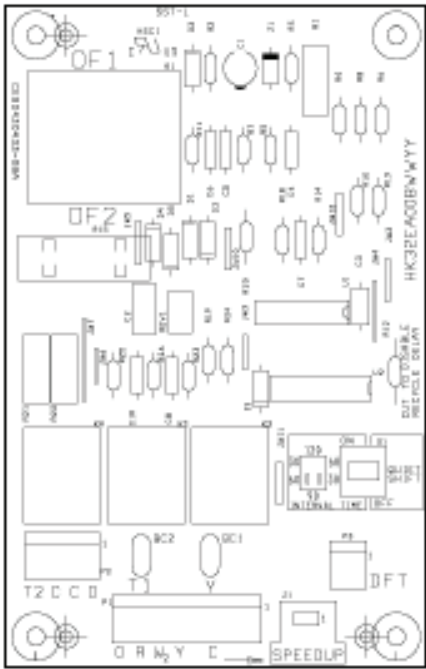

Fig. 12 - Defrost Control Board

A13151

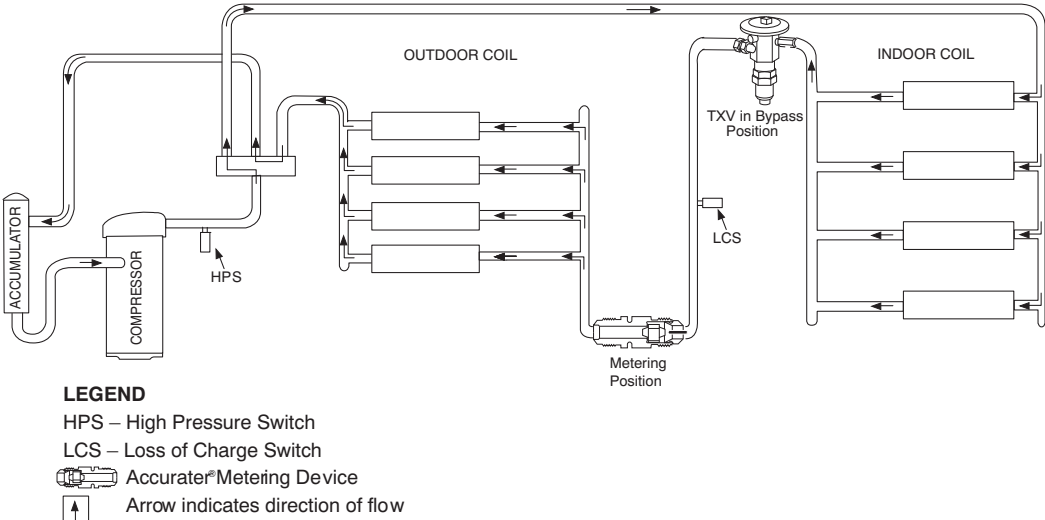

Fig. 13 - Typical Heat Pump Operation, Heating Mode

C03012

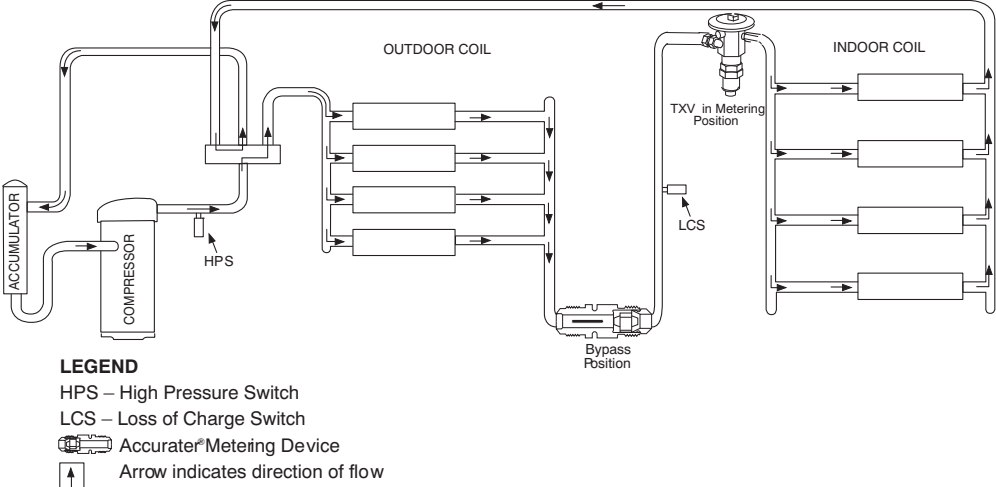

Fig. 14 - Typical Heat Pump Operation, Cooling Mode

C03011

Table 5 – Dry Coil Air Delivery* - Horizontal and Downflow Discharge - Unit 50VR--24-60 Without Advanced Dehumidification (AD) FIOP 208/230 VAC Models

UNIT	MOTOR SPEED	WIRE COLOR	EXTERNAL STATIC PRESSURE (IN. W.C.)																			
			0.1	0.2	0.3	0.4	0.5	0.6	0.7	0.8	0.9	1.0										
C24	Low ¹	Blue	CFM	777	692	583	465	318	---	---	---	---	---	---	---	---	---	---	---	---	---	
			BHP	0.09	0.10	0.10	0.11	0.12	---	---	---	---	---	---	---	---	---	---	---	---	---	---
	Med-Low	Pink	CFM	877	779	698	598	519	410	---	---	---	---	---	---	---	---	---	---	---	---	---
			BHP	0.12	0.12	0.13	0.14	0.15	0.15	---	---	---	---	---	---	---	---	---	---	---	---	---
	Medium ²	Red	CFM	904	841	769	705	628	522	372	---	---	---	---	---	---	---	---	---	---	---	---
			BHP	0.16	0.17	0.17	0.18	0.19	0.19	0.20	---	---	---	---	---	---	---	---	---	---	---	---
	Med-High	Orange	CFM	1229	1171	1105	1049	980	913	838	775	679	516	---	---	---	---	---	---	---	---	---
			BHP	0.28	0.30	0.30	0.31	0.32	0.33	0.34	0.33	0.34	0.34	0.33	---	---	---	---	---	---	---	---
	High	Black	CFM	1291	1206	1142	1081	1017	951	888	823	753	668	---	---	---	---	---	---	---	---	---
			BHP	0.31	0.32	0.33	0.34	0.34	0.35	0.36	0.36	0.37	0.37	0.37	---	---	---	---	---	---	---	---
C30	Low	Blue	CFM	777	692	583	465	318	---	---	---	---	---	---	---	---	---	---	---	---	---	---
			BHP	0.09	0.10	0.10	0.11	0.12	---	---	---	---	---	---	---	---	---	---	---	---	---	---
	Med-Low ¹	Pink	CFM	831	765	670	586	466	299	---	---	---	---	---	---	---	---	---	---	---	---	---
			BHP	0.11	0.12	0.12	0.13	0.13	0.14	---	---	---	---	---	---	---	---	---	---	---	---	---
	Medium ²	Red	CFM	1139	1069	1012	937	870	786	724	626	512	381	---	---	---	---	---	---	---	---	---
			BHP	0.22	0.23	0.24	0.24	0.25	0.26	0.26	0.26	0.27	0.27	0.28	---	---	---	---	---	---	---	---
	Med-High	Orange	CFM	1229	1171	1105	1049	980	913	838	775	679	516	---	---	---	---	---	---	---	---	---
			BHP	0.28	0.30	0.30	0.31	0.32	0.33	0.34	0.33	0.34	0.34	0.33	---	---	---	---	---	---	---	---
	High	Black	CFM	1531	1460	1382	1301	1209	1114	1003	890	764	629	---	---	---	---	---	---	---	---	---
			BHP	0.53	0.52	0.50	0.48	0.46	0.44	0.42	0.42	0.40	0.37	0.35	---	---	---	---	---	---	---	---
Low	Blue	CFM	1097	971	823	747	669	636	558	513	456	412	---	---	---	---	---	---	---	---	---	
		BHP	0.12	0.11	0.10	0.11	0.12	0.13	0.13	0.13	0.14	0.15	0.16	---	---	---	---	---	---	---	---	
Med-Low ¹	Pink	CFM	934	864	810	745	698	649	571	525	486	428	---	---	---	---	---	---	---	---	---	
		BHP	0.10	0.10	0.11	0.12	0.13	0.14	0.14	0.14	0.15	0.16	0.17	---	---	---	---	---	---	---	---	
Medium ²	Red	CFM	1251	1198	1149	1104	1066	1017	970	932	892	839	---	---	---	---	---	---	---	---	---	
		BHP	0.19	0.21	0.21	0.23	0.24	0.25	0.26	0.26	0.27	0.28	0.29	---	---	---	---	---	---	---	---	
Med-High	Orange	CFM	1451	1415	1372	1327	1287	1249	1212	1168	1130	1094	---	---	---	---	---	---	---	---	---	
		BHP	0.29	0.30	0.31	0.32	0.32	0.35	0.36	0.36	0.37	0.38	0.39	---	---	---	---	---	---	---	---	
High	Black	CFM	1466	1423	1384	1343	1308	1263	1219	1183	1145	1106	---	---	---	---	---	---	---	---	---	
		BHP	0.30	0.31	0.33	0.34	0.35	0.36	0.37	0.37	0.38	0.40	0.41	---	---	---	---	---	---	---	---	

Table 5 - Dry Coil Air Delivery* - Horizontal and Downflow Discharge (CONT)- Unit 50VR--24-60 Without Advanced Dehumidification (AD) FIOP 208/230 VAC Model

UNIT	MOTOR SPEED	WIRE COLOR	EXTERNAL STATIC PRESSURE (IN. W.C.)												
			0.1	0.2	0.3	0.4	0.5	0.6	0.7	0.8	0.9	1.0			
A42	Low	CFM	1097	971	823	747	669	636	558	513	456	412			
		BHP	0.12	0.11	0.10	0.11	0.12	0.13	0.13	0.14	0.15	0.16			
	Med-Low ¹	CFM	1076	1026	972	918	872	827	771	714	666	611			
		BHP	0.13	0.14	0.15	0.15	0.17	0.18	0.18	0.20	0.21	0.22			
	Medium	CFM	1251	1198	1149	1104	1066	1017	970	932	892	839			
		BHP	0.19	0.21	0.21	0.23	0.24	0.25	0.26	0.27	0.28	0.29			
	Med-High ²	CFM	1451	1415	1372	1327	1287	1249	1212	1168	1130	1094			
		BHP	0.29	0.30	0.31	0.32	0.35	0.35	0.36	0.37	0.38	0.39			
	High	CFM	1633	1590	1552	1518	1483	1444	1406	1372	1340	1303			
		BHP	0.41	0.43	0.44	0.45	0.47	0.48	0.49	0.50	0.51	0.53			
Low ¹	CFM	1271	1229	1177	1121	1066	1027	974	942	887	839				
	BHP	0.19	0.20	0.21	0.23	0.24	0.25	0.26	0.27	0.28	0.29				
Med-Low	CFM	1340	1299	1240	1191	1139	1091	1050	1001	952	895				
	BHP	0.22	0.23	0.24	0.25	0.26	0.28	0.29	0.30	0.31	0.32				
Medium ²	CFM	1686	1650	1617	1576	1544	1503	1468	1433	1393	1356				
	BHP	0.42	0.44	0.45	0.46	0.48	0.49	0.51	0.52	0.53	0.55				
Med-High	CFM	1854	1837	1781	1784	1720	1698	1655	1625	1578	1532				
	BHP	0.56	0.57	0.60	0.59	0.62	0.63	0.64	0.66	0.67	0.67				
High	CFM	1934	1900	1855	1815	1778	1737	1695	1656	1606	1528				
	BHP	0.59	0.61	0.62	0.64	0.65	0.67	0.68	0.70	0.70	0.68				
Low	CFM	1182	1137	1102	1053	1012	966	920	868	830	783				
	BHP	0.21	0.22	0.23	0.24	0.25	0.26	0.27	0.28	0.30	0.31				
Med-Low ¹	CFM	1454	1405	1364	1316	1281	1234	1198	1147	1105	1056				
	BHP	0.34	0.35	0.36	0.37	0.38	0.40	0.41	0.42	0.43	0.45				
Medium ²	CFM	1818	1770	1731	1693	1657	1621	1579	1546	1505	1436				
	BHP	0.56	0.57	0.59	0.60	0.62	0.63	0.64	0.66	0.67	0.66				
Med-High	CFM	1881	1849	1818	1793	1763	1729	1679	1610	1523	1479				
	BHP	0.67	0.69	0.70	0.71	0.72	0.73	0.73	0.71	0.68	0.65				
High	CFM	2138	2084	2025	1967	1893	1829	1754	1678	1591	1475				
	BHP	0.98	0.95	0.93	0.90	0.86	0.84	0.80	0.76	0.74	0.68				

* Air delivery values are without air filter and are for dry coil (See Wet Coil Pressure Drop table).

1 Factory--shipped low stage cooling speed.

2 Factory--shipped high stage cooling speed.

Note: Ducted field--supplied air filter pressure drop and wet coil pressure drop to obtain external static pressure available for ducting.

Shaded areas indicate acceptable Dehum. Speeds (Dehum. Mode is High Stage Only, 208/230 VAC Models Only).



Table 6 – Dry Coil Air Delivery* - Horizontal and Downflow Discharge - Unit 50VR-(A,C)24-60 With Advanced Dehumidification (AD) F1OP 208/230 VAC Model

UNIT SIZE	CFM ADJUST PIN SELECT	LO PIN			NOM PIN			HI PIN			
		0.0 – 0.39	0.4 – 0.69	0.7 – 1.0	0.0 – 0.39	0.4 – 0.69	0.7 – 1.0	0.0 – 0.39	0.4 – 0.69	0.7 – 1.0	
C24	HIGH STAGE	COOLING	770	795	790	855	885	875	940	975	965
		COOLING WITH DEHUMIDIFY	610	615	570	675	685	635	745	755	700
	LOW STAGE	COOLING WITH DEHUMIDIFY	475	470	360	530	520	401	585	570	440
C30	HIGH STAGE	COOLING	905	935	935	1005	1040	1040	1105	1145	1145
		COOLING WITH DEHUMIDIFY	715	740	725	795	820	803	875	900	885
	LOW STAGE	COOLING	715	740	730	795	820	810	875	900	890
A36	HIGH STAGE	COOLING WITH DEHUMIDIFY	555	555	485	615	615	540	675	675	595
		COOLING	1060	1100	1095	1175	1220	1215	1295	1340	1335
	LOW STAGE	COOLING WITH DEHUMIDIFY	845	880	875	940	975	970	1035	1075	1065
A42	HIGH STAGE	COOLING	835	850	845	930	945	940	1025	1040	1035
		COOLING WITH DEHUMIDIFY	675	685	670	750	760	745	825	835	820
	LOW STAGE	COOLING	1240	1265	1275	1375	1405	1414	1515	1545	1555
A48	HIGH STAGE	COOLING WITH DEHUMIDIFY	1010	1040	1015	1120	1155	1125	1230	1270	1240
		COOLING	970	975	965	1075	1085	1070	1185	1195	1175
	LOW STAGE	COOLING WITH DEHUMIDIFY	785	790	790	870	880	875	955	970	965
A60	HIGH STAGE	COOLING	1445	1450	1445	1605	1610	1605	1765	1770	1765
		COOLING WITH DEHUMIDIFY	1155	1170	1255	1285	1300	1395	1415	1430	1535
	LOW STAGE	COOLING	1095	1105	1095	1215	1225	1215	1335	1350	1335
A60	HIGH STAGE	COOLING WITH DEHUMIDIFY	880	890	875	975	990	970	1075	1090	1065
		COOLING	1565	1570	1555	1740	1745	1725	1915	1920	1900
	LOW STAGE	COOLING WITH DEHUMIDIFY	1270	1280	1280	1410	1424	1420	1550	1565	1560
	COOLING	1250	1265	1260	1390	1405	1400	1530	1545	1540	
	COOLING WITH DEHUMIDIFY	1015	1015	1015	1125	1130	1125	1240	1245	1240	

NOTE: Field-supplied air filter and wet coil pressure drop will minimally affect air delivery values.
Continuous Fan CFM is 50% of High Stage Cooling Airflow.

Table 7 – Dry Coil Air Delivery* - Horizontal and Downflow Discharge - Unit 50VR--24-60 Without Advanced Dehumidification (AD) FIOP 460V/AC Models

UNIT	MOTOR SPEED	WIRE COLOR	EXTERNAL STATIC PRESSURE (IN. W.C.)											
			0.1	0.2	0.3	0.4	0.5	0.6	0.7	0.8	0.9	1.0		
A36	Low ¹	Blue	CFM	934	864	810	745	698	649	571	525	486	428	
			BHP	0.10	0.10	0.11	0.12	0.13	0.14	0.14	0.15	0.16	0.17	
	Med-Low	Pink	CFM	1076	1026	972	918	872	827	771	714	666	611	
			BHP	0.13	0.14	0.15	0.15	0.17	0.18	0.18	0.20	0.21	0.22	
	Medium	Red	CFM	1213	1169	1110	1065	1016	964	923	878	820	777	
			BHP	0.16	0.17	0.17	0.19	0.20	0.21	0.22	0.23	0.24	0.25	
	Med-High ²	Orange	CFM	1251	1198	1149	1104	1066	1017	970	932	892	839	
			BHP	0.19	0.21	0.21	0.23	0.24	0.25	0.26	0.27	0.28	0.29	
	High	Black	CFM	1451	1415	1372	1327	1287	1249	1212	1168	1130	1094	
			BHP	0.29	0.30	0.31	0.32	0.35	0.35	0.36	0.37	0.38	0.39	
A42	Low ¹	Blue	CFM	1076	1026	972	918	872	827	771	714	666	611	
			BHP	0.13	0.14	0.15	0.15	0.17	0.18	0.18	0.20	0.21	0.22	
	Med-Low	Pink	CFM	1213	1169	1110	1065	1016	964	923	878	820	777	
			BHP	0.16	0.17	0.17	0.19	0.20	0.21	0.22	0.23	0.24	0.25	
	Medium	Red	CFM	1251	1198	1149	1104	1066	1017	970	932	892	839	
			BHP	0.19	0.21	0.21	0.23	0.24	0.25	0.26	0.27	0.28	0.29	
	Med-High ²	Orange	CFM	1451	1415	1372	1327	1287	1249	1212	1168	1130	1094	
			BHP	0.29	0.30	0.31	0.32	0.35	0.35	0.36	0.37	0.38	0.39	
	A48	High	Black	CFM	1633	1590	1552	1518	1483	1444	1406	1372	1340	1303
				BHP	0.41	0.43	0.44	0.45	0.47	0.48	0.49	0.50	0.51	0.53
Low ¹		Blue	CFM	1271	1229	1177	1121	1066	1027	974	942	887	839	
			BHP	0.19	0.20	0.21	0.23	0.24	0.25	0.26	0.27	0.28	0.29	
Med-Low		Pink	CFM	1340	1299	1240	1191	1139	1091	1050	1001	952	895	
			BHP	0.22	0.23	0.24	0.25	0.26	0.28	0.29	0.30	0.31	0.32	
Medium ²		Red	CFM	1686	1650	1617	1576	1544	1503	1468	1433	1393	1356	
			BHP	0.42	0.44	0.45	0.46	0.48	0.49	0.51	0.52	0.53	0.55	
Med-High		Orange	CFM	1854	1837	1781	1784	1720	1698	1655	1625	1578	1532	
			BHP	0.56	0.57	0.60	0.59	0.62	0.63	0.64	0.66	0.67	0.67	
High	Black	CFM	2131	2088	2065	2013	1982	1941	1888	1860	1785	1751		
		BHP	0.72	0.74	0.75	0.77	0.79	0.80	0.81	0.81	0.79	0.75		

50VR

Table 6 - Dry Coil Air Delivery* - Horizontal and Downflow Discharge - Unit 50VR--24-60 Without Advanced Dehumidification (AD) FIOP 460VAC Models

UNIT	MOTOR SPEED	WIRE COLOR	EXTERNAL STATIC PRESSURE (IN. W.C.)										
			0.1	0.2	0.3	0.4	0.5	0.6	0.7	0.8	0.9	1.0	
A60	Low	Blue	CFM	1415	1384	1340	1314	1270	1236	1192	1159	1116	1076
			BHP	0.32	0.34	0.35	0.36	0.37	0.39	0.41	0.42	0.44	
	Med-Low ¹	Pink	CFM	1454	1405	1364	1316	1281	1234	1198	1147	1105	1056
			BHP	0.34	0.35	0.36	0.37	0.38	0.40	0.41	0.42	0.43	0.45
	Medium ²	Red	CFM	1818	1770	1731	1693	1657	1621	1579	1546	1505	1436
			BHP	0.56	0.57	0.59	0.60	0.62	0.63	0.64	0.66	0.67	0.66
	Med-High	Orange	CFM	1881	1849	1818	1793	1763	1729	1679	1610	1523	1479
			BHP	0.67	0.69	0.70	0.71	0.72	0.73	0.73	0.71	0.68	0.65
	High	Black	CFM	2138	2084	2025	1967	1893	1829	1754	1678	1591	1475
			BHP	0.98	0.95	0.93	0.90	0.86	0.84	0.80	0.76	0.74	0.68

* Air delivery values are without air filter and are for dry coil (See Wet Coil Pressure Drop table).

¹ Factory—shipped low stage cooling speed.

² Factory—shipped high stage cooling speed.

Note: Deduct field—supplied air filter pressure drop and wet coil pressure drop to obtain external static pressure available for ducting.

Table 8 – Wet Coil Pressure Drop (IN. W.C.)

UNIT SIZE	STANDARD CFM (SCFM)																
	600	700	800	900	1000	1100	1200	1300	1400	1500	1600	1700	1800	1900	2000	2100	2200
24	0.03	0.04	0.05	0.06	0.07												
30				0.06	0.07	0.07	0.08	0.09									
36				0.06	0.07	0.08	0.09	0.10	0.11								
42				0.06	0.07	0.08	0.09	0.10	0.11	0.11	0.12	0.12					
48						0.03	0.04	0.08	0.08	0.08	0.10	0.11	0.14	0.15	0.16		
60								0.08	0.08	0.10	0.10	0.11	0.14	0.15	0.16	0.16	

Table 9 – Economizer with 1-in. Filter Pressure Drop (IN. W.C.)

FILTER SIZE IN. (MM)	COOLING TONS	STANDARD CFM (SCFM)																
		600	700	800	900	1000	1100	1200	1300	1400	1500	1600	1700	1800	1900	2000	2100	2200
600-1400CFM 12x20x1+12x20x1 (305x508x25+305x508x25)	2.0,	-	-	0.09	0.14	0.16	0.18	0.25	0.28	0.3	-	-	-	-	-	-	-	-
	2.5																	
1200-1800 CFM 16x24x1+14x24x1 (406x610x25+356x610x25)	3.0,	-	-	-	-	-	-	0.10	0.11	0.12	0.13	0.14	0.16	0.16	-	-	-	-
	3.5																	
1500-2200 CFM 16x24x1+18x24x1 (406x610x25+457x610x25)	4.0	-	-	-	-	-	-	-	-	-	0.15	0.17	0.18	0.20	0.21	0.22	0.23	0.23
	5.0																	

Table 10 – Filter Pressure Drop Table (IN. W.C.)

FILTER SIZE IN. (MM)	COOLING TONS	STANDARD CFM (SCFM)																
		600	700	800	900	1000	1100	1200	1300	1400	1500	1600	1700	1800	1900	2000	2100	2200
600-1400CFM 12x20x1+12x20x1 (305x508x25+305x508x25)	2.0,	0.03	0.05	0.06	0.08	0.10	0.11	0.13	0.14	0.16	-	-	-	-	-	-	-	-
	2.5																	
1200-1800 CFM 16x24x1+14x24x1 (406x610x25+356x610x25)	3.0,	-	-	-	-	-	-	0.07	0.08	0.09	0.09	0.10	0.11	0.12	-	-	-	-
	3.5																	
1500-2200 CFM 16x24x1+18x24x1 (406x610x25+457x610x25)	4.0	-	-	-	-	-	-	-	-	-	0.04	0.06	0.08	0.10	0.11	0.13	0.14	0.15
	5.0																	

Table 11 – Electric Heat Pressure Drop Tables (IN. W.C.)
Small Cabinet: 24-30

STATIC	STANDARD CFM (SCFM)															
	500	600	700	800	900	1000	1100	1200	1300	1400	1500	1600				
5 kW	0.00	0.00	0.00	0.00	0.00	0.00	0.00	0.00	0.02	0.02	0.04	0.06	0.07	0.09	0.10	0.11
10 kW	0.00	0.00	0.00	0.00	0.00	0.02	0.04	0.06	0.07	0.09	0.10	0.11	0.12	0.13	0.14	0.15
15 kW	0.00	0.00	0.00	0.02	0.04	0.06	0.08	0.10	0.12	0.14	0.16	0.18	0.19	0.20	0.21	0.22
20 kW	0.00	0.00	0.02	0.04	0.06	0.08	0.09	0.11	0.13	0.15	0.17	0.19	0.21	0.22	0.23	0.24

Large Cabinet: 36-60

STATIC	STANDARD CFM (SCFM)															
	1100	1200	1300	1400	1500	1600	1700	1800	1900	2000	2100	2200	2300	2400	2500	
5 kW	0.00	0.00	0.00	0.01	0.02	0.03	0.04	0.05	0.06	0.07	0.08	0.09	0.10	0.11	0.12	
10 kW	0.00	0.00	0.01	0.02	0.03	0.04	0.05	0.06	0.07	0.08	0.09	0.10	0.11	0.12	0.13	
15 kW	0.00	0.02	0.03	0.04	0.05	0.06	0.07	0.08	0.09	0.10	0.11	0.12	0.13	0.14	0.15	
20 kW	0.02	0.03	0.04	0.05	0.06	0.07	0.08	0.09	0.10	0.11	0.12	0.13	0.14	0.15	0.16	

CONNECTION WIRING DIAGRAM

DANGER: ELECTRICAL SHOCK HAZARD DISCONNECT POWER BEFORE SERVICING

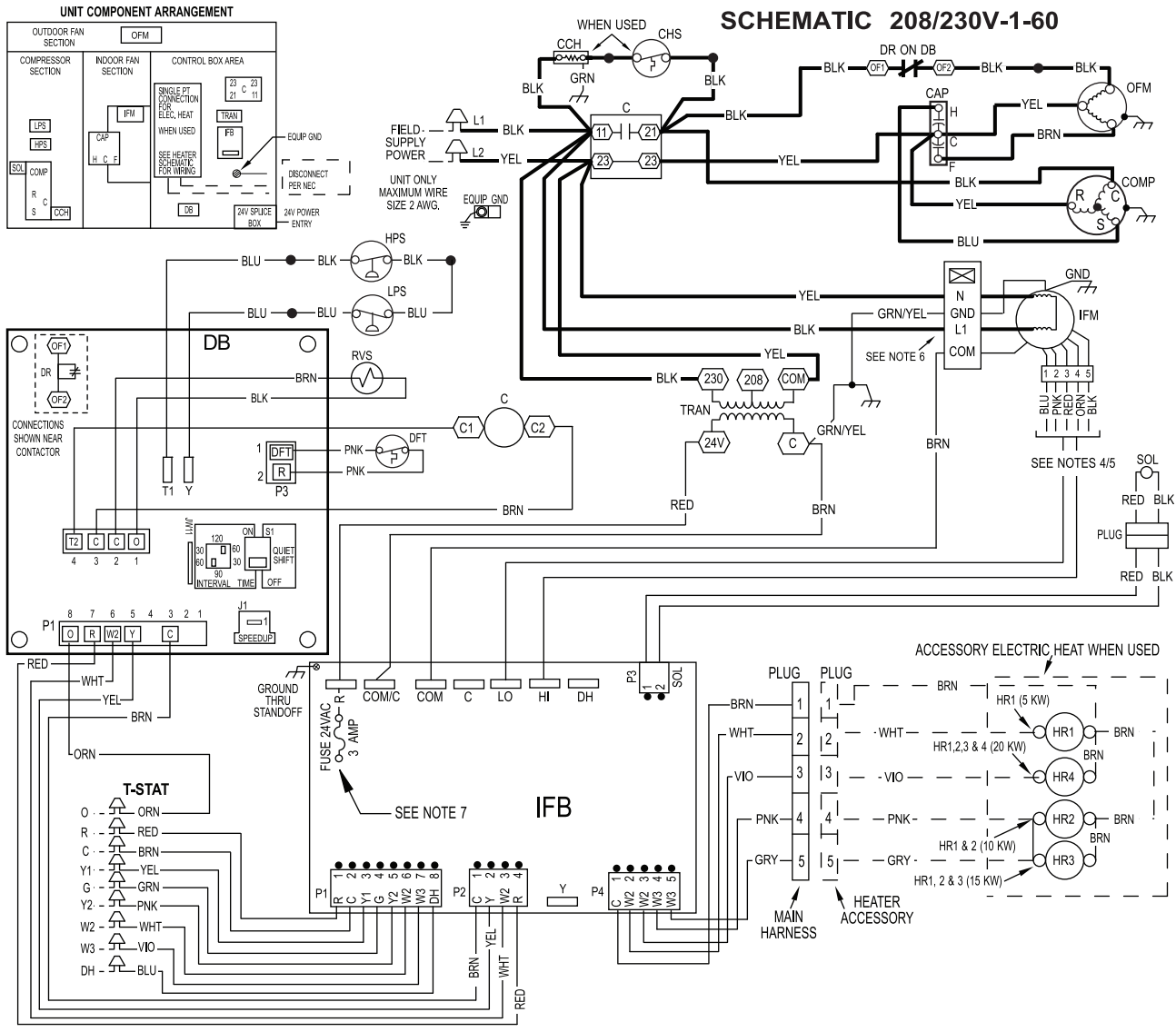

50VR

NOTES:

1. IF ANY OF THE ORIGINAL WIRES FURNISHED ARE REPLACED IT MUST BE REPLACED WITH THE SAME OR ITS EQUIVALENT.
2. SEE PRE SALE LITERATURE FOR THERMOSTATS.
3. USE 75 DEGREES C COPPER CONDUCTORS FOR FIELD INSTALLATION.
4. REFER TO INSTALLATION INSTRUCTIONS FOR CORRECT SPEED SELECTION FOR IFM.
5. RELOCATION OF SPEED TAPS MAY BE REQUIRED WHEN USING FIELD INSTALLED ELECTRIC HEATERS. CONSULT INSTALLATION INSTRUCTIONS TO DETERMINE CORRECT SPEED TAP SETTING.
6. "DO NOT DISCONNECT PLUG UNDER LOAD".
7. THIS FUSE IS MANUFACTURED BY LITTLE FUSE, P/N 287003.

LEGEND

	FIELD SPLICE	C	CONTACTOR	IFM	INDOOR FAN MOTOR
	TERMINAL (MARKED)	CAP	CAPACITOR	LPS	LOW PRESSURE SWITCH
	TERMINAL (UNMARKED)	CCH	CRANKCASE HEATER	OFM	OUTDOOR FAN MOTOR
	SPLICE	CHS	CRANKCASE HEATER SWITCH	RVS	REVERSING VALVE
	SPLICE (MARKED)	COMP	COMPRESSOR MOTOR	SOL	COMPRESSOR SOLENOID
	FACTORY LO VOLTAGE	CTD	COMPRESSOR TIME DELAY	TRAN	TRANSFORMER
	FIELD CONTROL WIRING	DH	DEHUM	T-STAT	THERMOSTAT
	FIELD POWER WIRING	DB	DEFROST BOARD		
	ACCESSORY OR OPTIONAL WIRING	DFT	DEFROST TEMPERATURE SWITCH		
	FACTORY HI VOLTAGE	DR	DEFROST RELAY		
		GND	GROUND		
		HPS	HIGH PRESSURE SWITCH		
		HR	HEATER RELAY		
		IFB	INDOOR FAN BOARD		

Fig. 15 - Connection Wiring Diagram without Advanced Dehumidification (AD) FIOP 208/230-1-60

A13144

LADDER WIRING DIAGRAM

DANGER: ELECTRICAL SHOCK HAZARD DISCONNECT POWER BEFORE SERVICING

DIP SWITCH SETTINGS

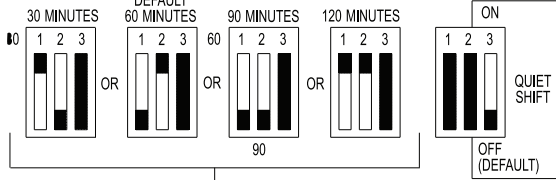

FIELD SELECTABLE OPTIONS FOR TIME PERIOD BETWEEN DEFROST CYCLES (MINUTES)

SPEED UP JUMPED TEST PINS (USE METAL OBJECT) FIELD SPEED-UP CYCLE

- MOMENTARILY SHORT PINS AND RELEASE TO BYPASS COMPRESSOR OFF DELAY.
- SHORT FOR 5+ SEC. AND RELEASE FOR FORCED DEFROST.
- PERMANENT SHORT WILL BE IGNORED.

DEFROST WILL TERMINATE IN 30 SEC. IF DFT OPEN.
DEFROST WILL TERMINATE NORMALLY IF DFT IS CLOSED.

THE COMPRESSOR WILL SHUT OFF FOR 30 SEC. ON DEFROST INITIATION AND TERMINATION IN THE "QUIET SHIFT" ON POSITION.

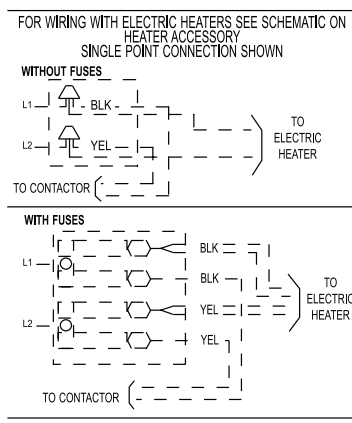
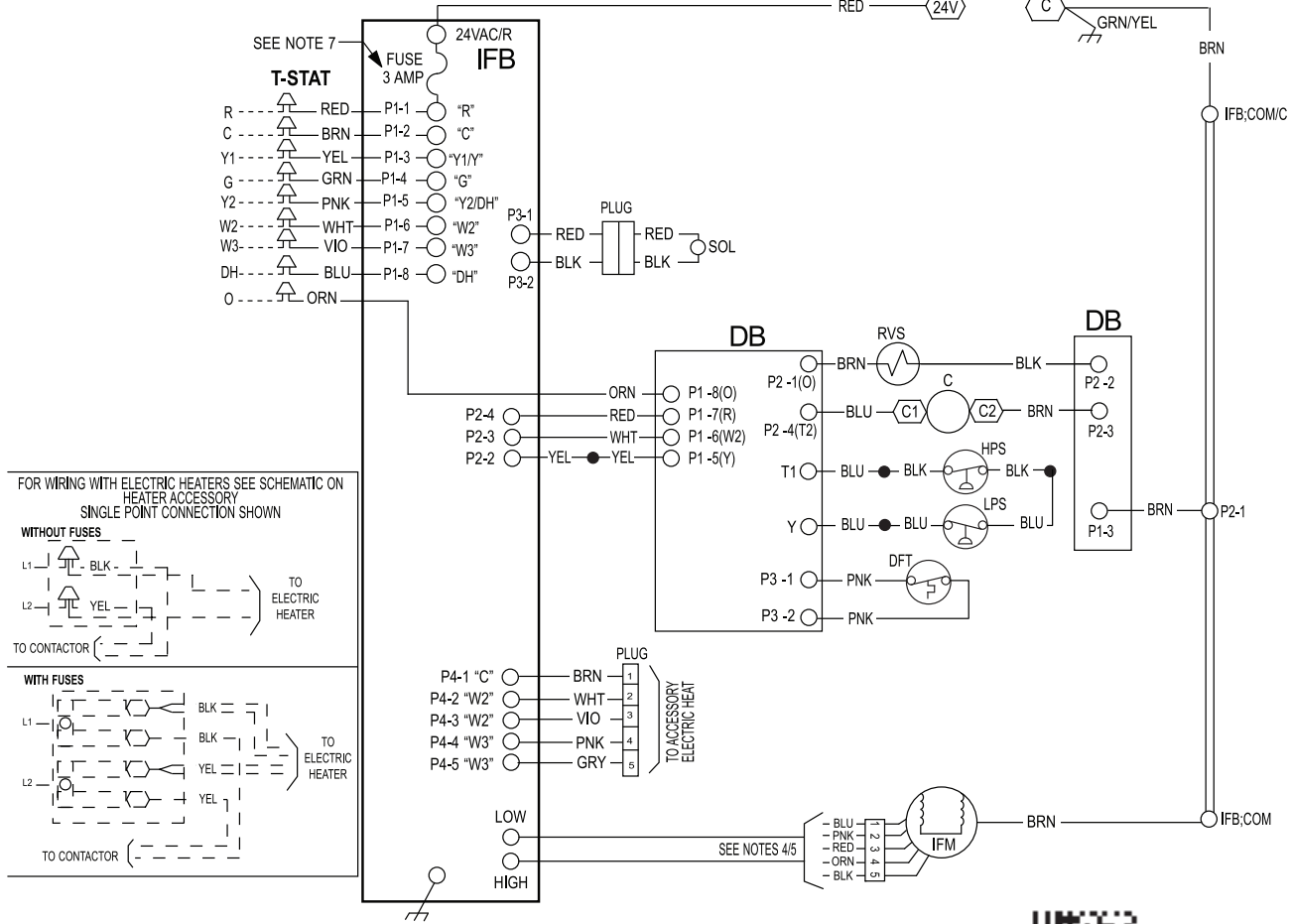
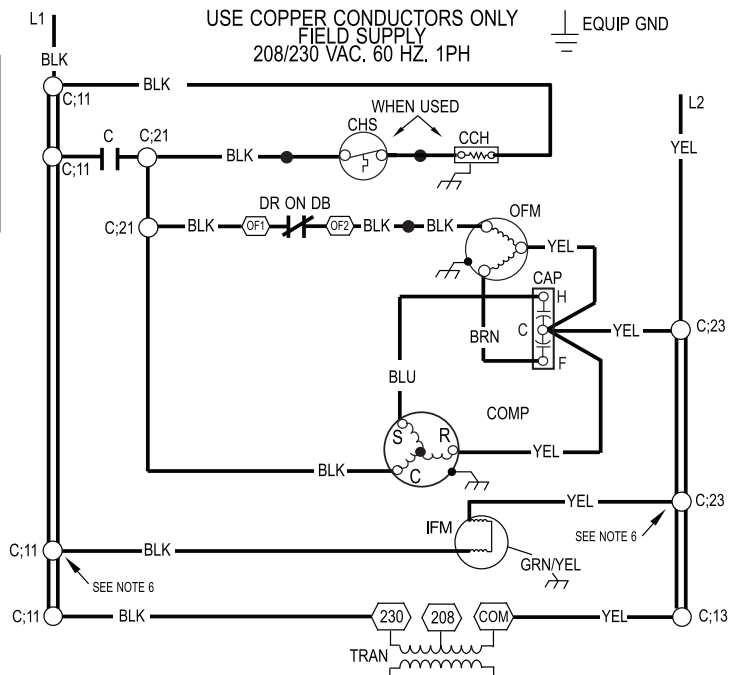
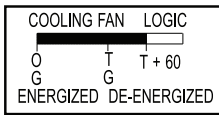
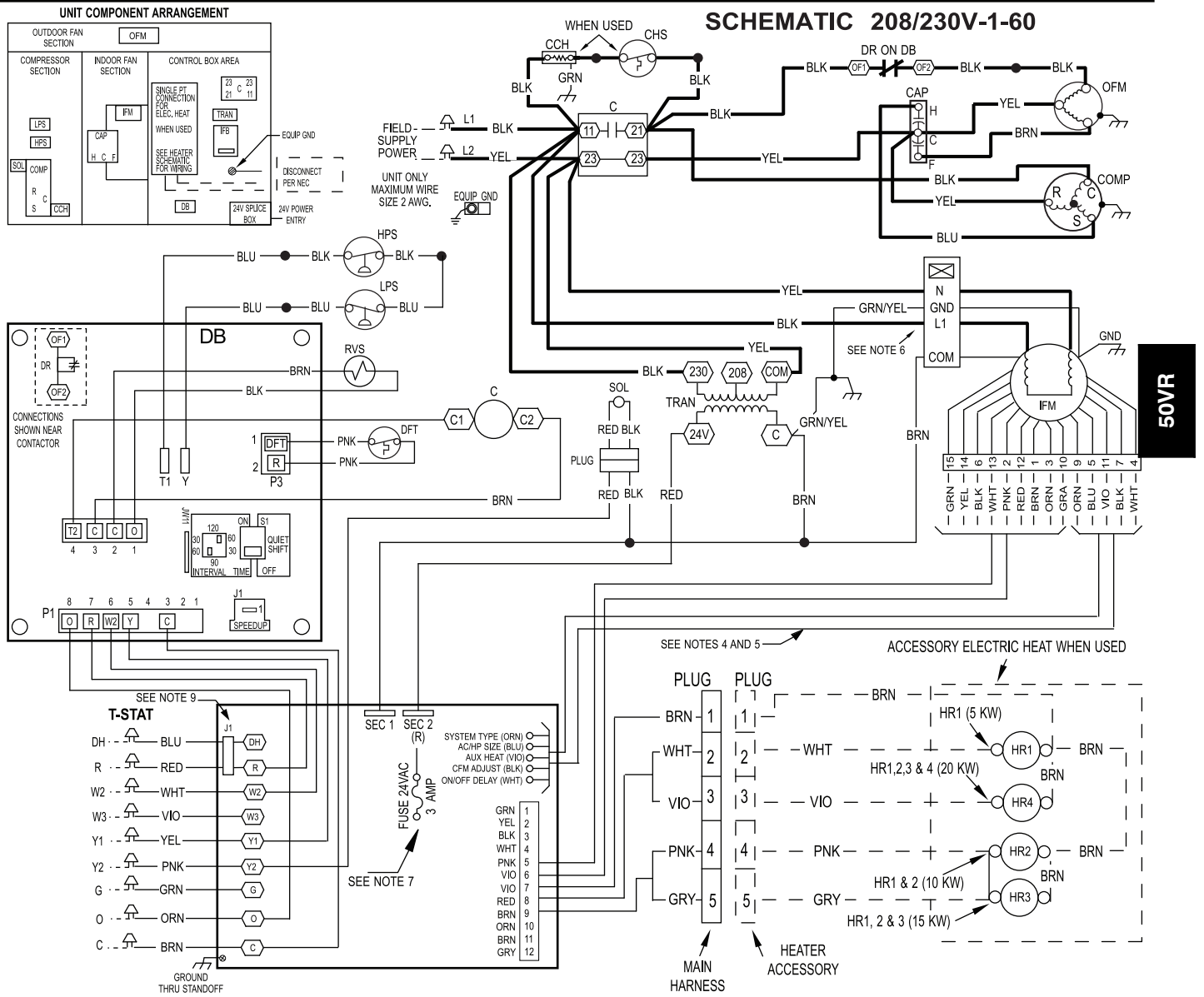

Fig. 15 Cont. - Ladder Wiring Diagram without Advanced Dehumidification (AD) FIOP 208/230-1-60

50VR

CONNECTION WIRING DIAGRAM

DANGER: ELECTRICAL SHOCK HAZARD DISCONNECT POWER BEFORE SERVICING



NOTES:

1. IF ANY OF THE ORIGINAL WIRES FURNISHED ARE REPLACED IT MUST BE REPLACED WITH THE SAME OR ITS EQUIVALENT.
2. SEE PRE SALE LITERATURE FOR THERMOSTATS.
3. USE 75 DEGREES C COPPER CONDUCTORS FOR FIELD INSTALLATION.
4. REFER TO INSTALLATION INSTRUCTIONS FOR CORRECT SPEED SELECTION FOR IFM.
5. RELOCATION OF SPEED TAPS MAY BE REQUIRED WHEN USING FIELD INSTALLED ELECTRIC HEATERS. CONSULT INSTALLATION INSTRUCTIONS TO DETERMINE CORRECT SPEED TAP SETTING.
6. "DO NOT DISCONNECT PLUG UNDER LOAD".
7. THIS FUSE IS MANUFACTURED BY LITTLE FUSE, P/N 287003.
8. N.E.C. CLASS 2, 24V.
9. TO USE THE ADVANCED DEHUMIDIFICATION FEATURE, CUT JUMPER 1.

LEGEND

△	FIELD SPLICE	C	CONTACTOR	IFM	INDOOR FAN MOTOR
○	TERMINAL (MARKED)	CAP	CAPACITOR	LPS	LOW PRESSURE SWITCH
○	TERMINAL (UNMARKED)	CCH	CRANKCASE HEATER	OFM	OUTDOOR FAN MOTOR
●	SPLICE	CHS	CRANKCASE HEATER SWITCH	RVS	REVERSING VALVE
○	SPLICE (MARKED)	COMP	COMPRESSOR MOTOR	SOL	COMPRESSOR SOLENOID
---	FACTORY LO VOLTAGE	CTD	COMPRESSOR TIME DELAY	TRAN	TRANSFORMER
- - -	FIELD CONTROL WIRING	DEHM	DEHUM	T-STAT	THERMOSTAT
- · - · -	FIELD POWER WIRING	DB	DEFROST BOARD		
- · - · -	FIELD CONTROL WIRING	DFT	DEFROST TEMPERATURE SWITCH		
- · - · -	FIELD POWER WIRING	DR	DEFROST RELAY		
- · - · -	ACCESSORY OR OPTIONAL WIRING	GND	GROUND		
- · - · -	FACTORY HI VOLTAGE	HPS	HIGH PRESSURE SWITCH		
		HR	HEATER RELAY		
		IFB	INDOOR FAN BOARD		

Fig. 16 - Connection Wiring Diagram with Advanced Dehumidification (AD) FIOP 208/230-1-60

A180105

LADDER WIRING DIAGRAM

DANGER: ELECTRICAL SHOCK HAZARD DISCONNECT POWER BEFORE SERVICING

DIP SWITCH SETTINGS



FIELD SELECTABLE OPTIONS FOR TIME PERIOD BETWEEN DEFOST CYCLES (MINUTES)

SPEED UP JUMPERED TEST PINS (USE METAL OBJECT) FIELD SPEED-UP CYCLE

- 1) MOMENTARILY SHORT PINS AND RELEASE TO BYPASS COMPRESSOR OFF DELAY.
- 2) SHORT FOR 5+ SEC. AND RELEASE FOR FORCED DEFOST.
- 3) PERMANENT SHORT WILL BE IGNORED.

DEFOST WILL TERMINATE IN 30 SEC. IF DFT OPEN.
DEFOST WILL TERMINATE NORMALLY IF DFT IS CLOSED.

THE COMPRESSOR WILL SHUT OFF FOR 30 SEC. ON DEFOST INITIATION AND TERMINATION IN THE 'QUIET SHIFT' ON POSITION.

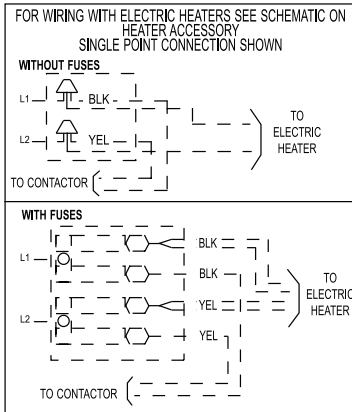
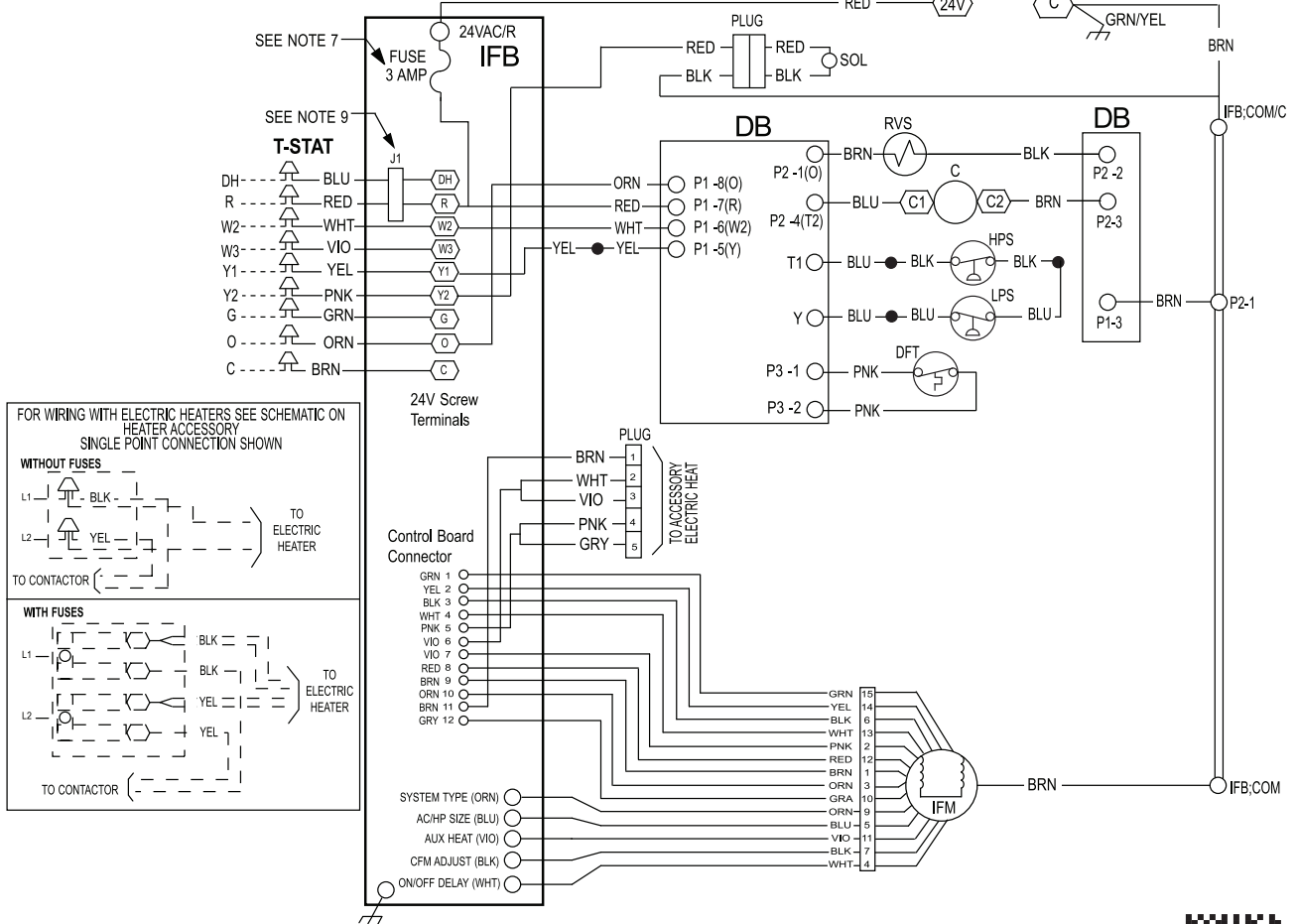
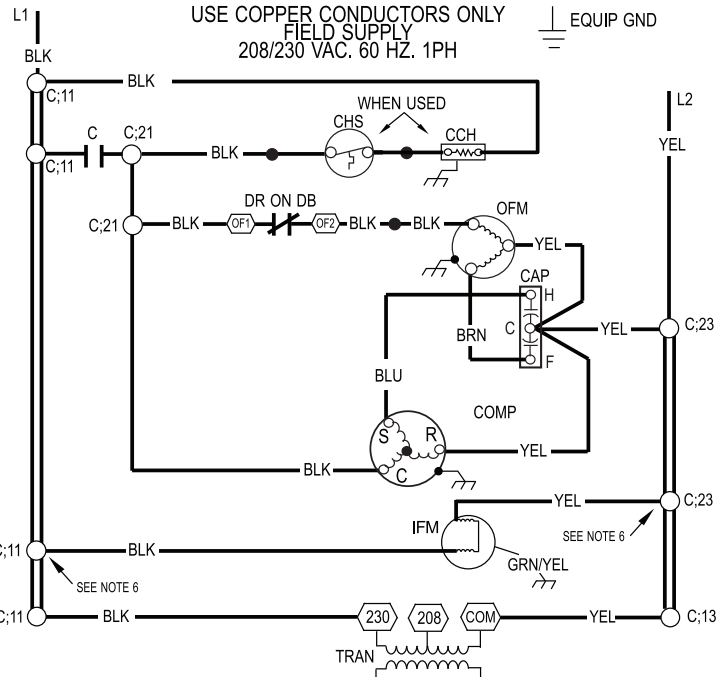
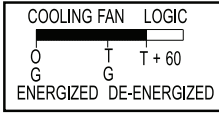

343959-101 REV.B

A180106

Fig. 16 Cont. - Ladder Wiring Diagram with Advanced Dehumidification (AD) FIOP 208/230-1-60

50VR

CONNECTION WIRING DIAGRAM

DANGER: ELECTRICAL SHOCK HAZARD DISCONNECT POWER BEFORE SERVICING

SCHEMATIC 208/230V-3-60

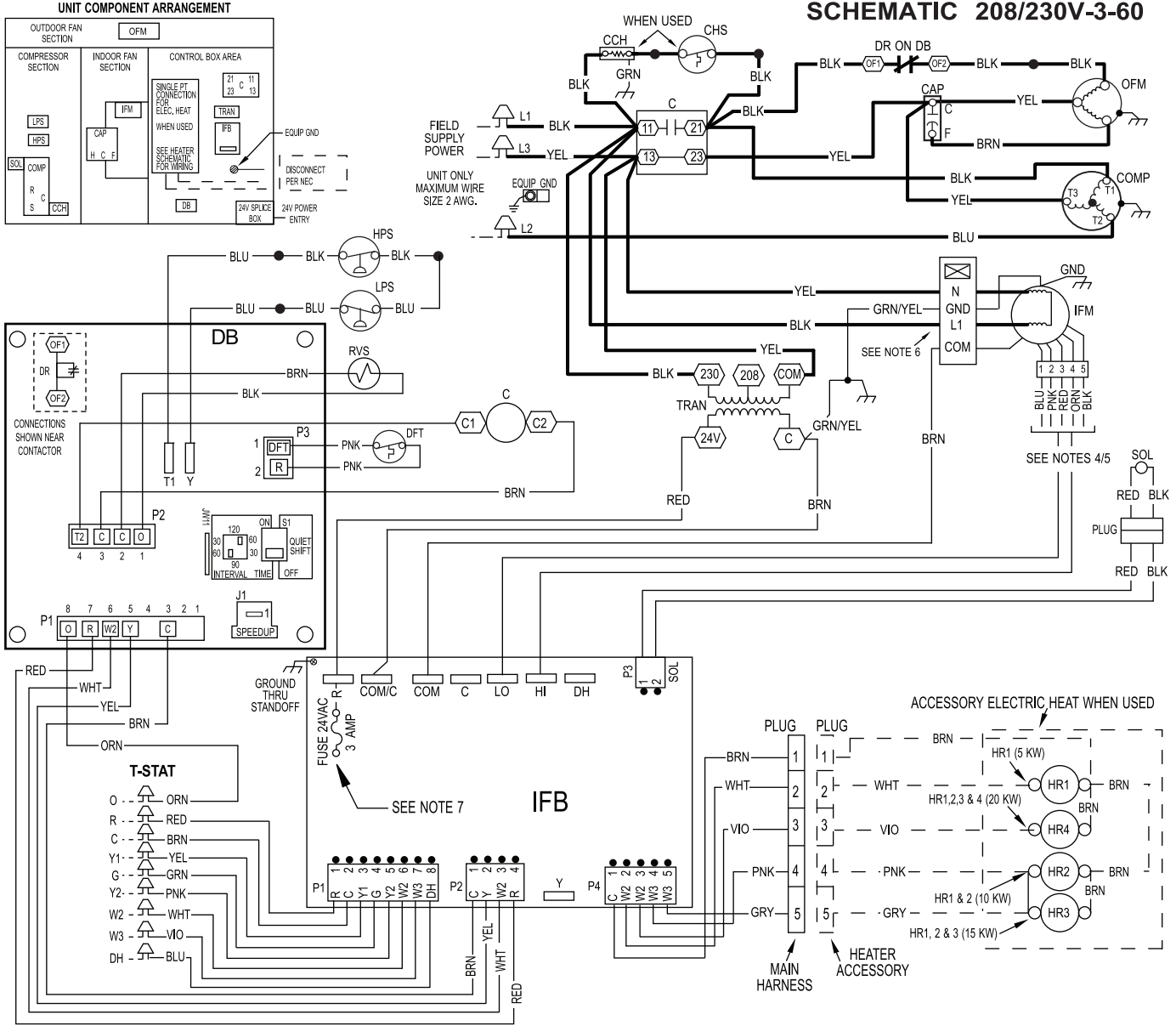

50VR

NOTES:

1. IF ANY OF THE ORIGINAL WIRES FURNISHED ARE REPLACED IT MUST BE REPLACED WITH THE SAME OR ITS EQUIVALENT.
2. SEE PRE SALE LITERATURE FOR THERMOSTATS.
3. USE 75 DEGREES C COPPER CONDUCTORS FOR FIELD INSTALLATION.
4. REFER TO INSTALLATION INSTRUCTIONS FOR CORRECT SPEED SELECTION FOR IFM.
5. RELOCATION OF SPEED TAPS MAY BE REQUIRED WHEN USING FIELD INSTALLED ELECTRIC HEATERS. CONSULT INSTALLATION INSTRUCTIONS TO DETERMINE CORRECT SPEED TAP SETTING.
6. "DO NOT DISCONNECT PLUG UNDER LOAD".
7. THIS FUSE IS MANUFACTURED BY LITTLE FUSE, P/N 287003.

LEGEND

	FIELD SPLICE	C	CONTACTOR	IFM	INDOOR FAN MOTOR
	TERMINAL (MARKED)	CAP	CAPACITOR	LPS	LOW PRESSURE SWITCH
	TERMINAL (UNMARKED)	CCH	CRANKCASE HEATER	OFM	OUTDOOR FAN MOTOR
	SPLICE	CHS	CRANKCASE HEATER SWITCH	RVS	REVERSING VALVE
	SPLICE (MARKED)	COMP	COMPRESSOR MOTOR	SOL	COMPRESSOR SOLENOID
	FACTORY LO VOLTAGE	CTD	COMPRESSOR TIME DELAY	TRAN	TRANSFORMER
	FIELD CONTROL WIRING	DH	DEHUM	T-STAT	THERMOSTAT
	FIELD POWER WIRING	DB	DEFROST BOARD		
	ACCESSORY OR OPTIONAL WIRING	DFT	DEFROST TEMPERATURE SWITCH		
	FACTORY HI VOLTAGE	DR	DEFROST RELAY		
		GND	GROUND		
		HPS	HIGH PRESSURE SWITCH		
		HR	HEATER RELAY		
		IFB	INDOOR FAN BOARD		

Fig. 17 - Connection Wiring Diagram 208/230-3-60

A13146

LADDER WIRING DIAGRAM

DANGER: ELECTRICAL SHOCK HAZARD DISCONNECT POWER BEFORE SERVICING

DIP SWITCH SETTINGS

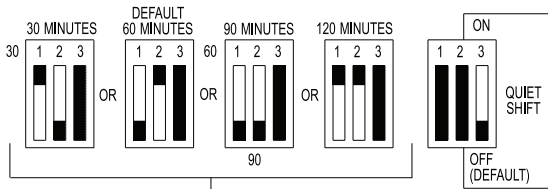

FIELD SELECTABLE OPTIONS FOR TIME PERIOD BETWEEN DEFROST CYCLES (MINUTES)

SPEED UP JUMPERED TEST PINS (USE METAL OBJECT) FIELD SPEED-UP CYCLE

- 1) MOMENTARILY SHORT PINS AND RELEASE TO BYPASS COMPRESSOR OFF DELAY.
- 2) SHORT FOR 5+ SEC. AND RELEASE FOR FORCED DEFROST.
- 3) PERMANENT SHORT WILL BE IGNORED.

DEFROST WILL TERMINATE IN 30 SEC. IF DFT OPEN.
DEFROST WILL TERMINATE NORMALLY IF DFT IS CLOSED.

THE COMPRESSOR WILL SHUT OFF FOR 30 SEC. ON DEFROST INITIATION AND TERMINATION IN THE "QUIET SHIFT" ON POSITION.

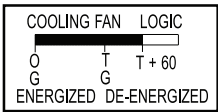

50VR

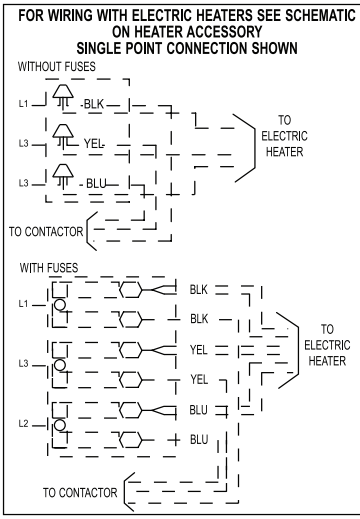
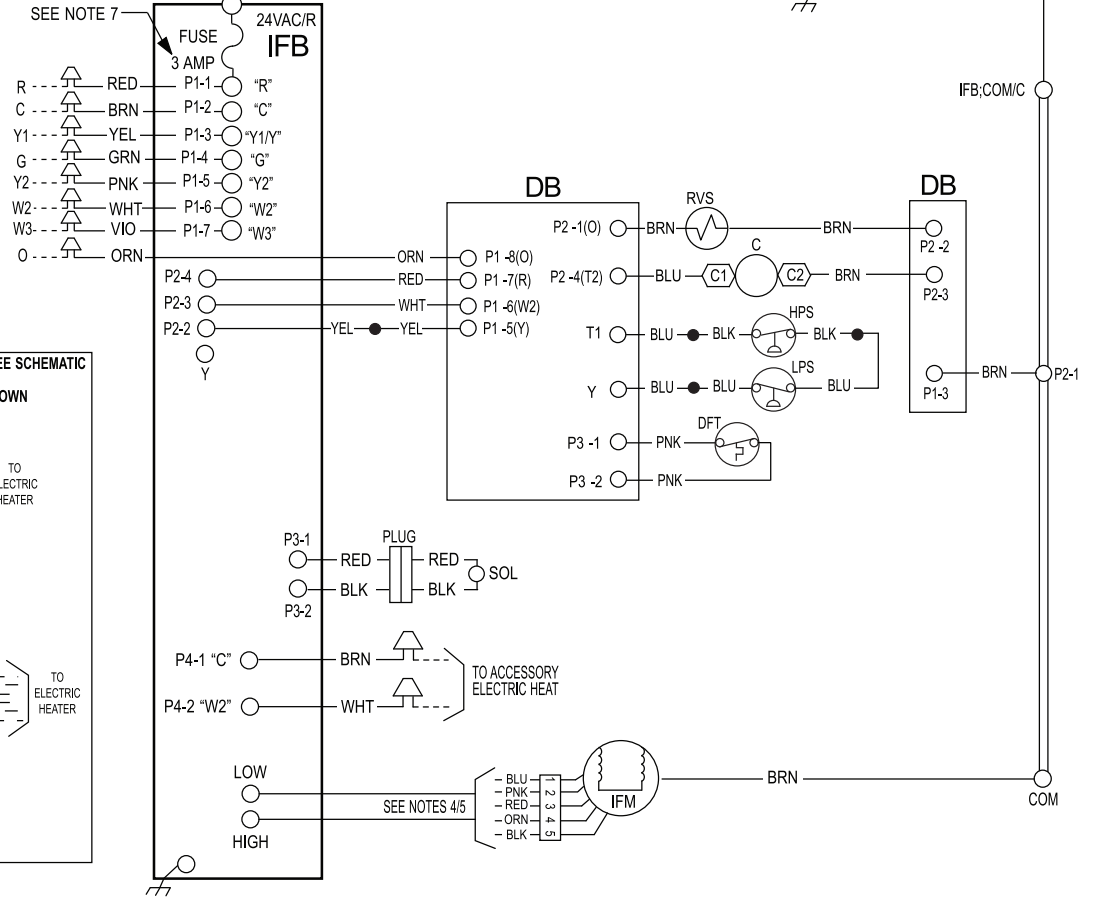
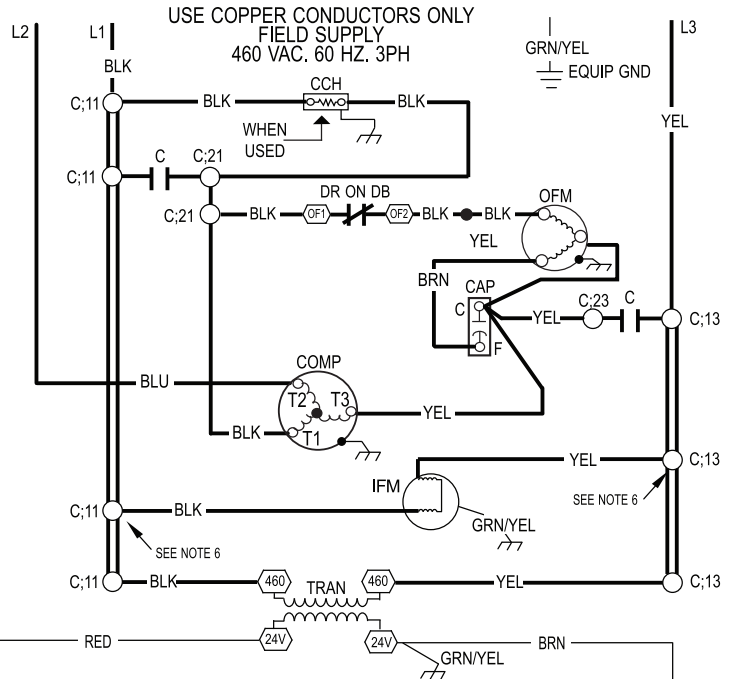

50VR500011 REV. -

Fig. 18 Cont. - Ladder Wiring Diagram 460-3-60

A13149

Required Subcooling °F(°C)						Required Liquid Line Temperature for a Specific Subcooling (R-410A)											
Model Size	Outdoor Ambient Temperature °F(°C)					Pressure (psig)	Required Subcooling (°F)					Pressure (kPa)	Required Subcooling (°C)				
	75 (24)	85 (29)	95 (35)	105 (41)	115 (46)		5	10	15	20	25		3	6	8	11	14
						189	61	56	51	46	41	1303	16	13	11	8	5
024	12 (6.9)	12 (6.9)	12 (6.9)	12 (6.9)	12 (6.9)	196	63	58	53	48	43	1351	17	15	12	9	6
030	13 (7.5)	12 (6.9)	12 (6.9)	12 (6.9)	11 (6.5)	203	66	61	56	51	46	1399	19	16	13	10	8
036	17 (9.4)	16 (8.8)	16 (8.8)	15 (8.2)	15 (8.2)	210	68	63	58	53	48	1448	20	17	14	11	9
042	14 (7.8)	14 (7.8)	13 (7.5)	13 (7.5)	13 (7.5)	217	70	65	60	55	50	1496	21	18	15	13	10
048	15 (8.2)	15 (8.2)	15 (8.2)	15 (8.2)	14 (7.8)	224	72	67	62	57	52	1544	22	19	16	14	11
060	17 (9.4)	16 (8.8)	16 (8.8)	15 (8.2)	15 (8.2)	231	74	69	64	59	54	1593	23	20	18	15	12
						238	76	71	66	61	56	1641	24	21	19	16	13
						245	77	72	67	62	57	1689	25	22	20	17	14
						252	79	74	69	64	59	1737	26	23	21	18	15
						260	81	76	71	66	61	1792	27	25	22	19	16
						268	83	78	73	68	63	1848	29	26	23	20	17
						276	85	80	75	70	65	1903	30	27	24	21	19
						284	87	82	77	72	67	1958	31	28	25	22	20
						292	89	84	79	74	69	2013	32	29	26	23	21
						300	91	86	81	76	71	2068	33	30	27	24	22
						309	93	88	83	78	73	2130	34	31	28	26	23
						318	95	90	85	80	75	2192	35	32	29	27	24
						327	97	92	87	82	77	2254	36	33	31	28	25
						336	99	94	89	84	79	2316	37	34	32	29	26
						345	101	96	91	86	81	2378	38	35	33	30	27
						354	103	98	93	88	83	2440	39	36	34	31	28
						364	105	100	95	90	85	2509	40	38	35	32	29
						374	107	102	97	92	87	2578	41	39	36	33	30
						384	108	103	98	93	88	2647	42	40	37	34	31
						394	110	105	100	95	90	2716	44	41	38	35	32
						404	112	107	102	97	92	2785	45	42	39	36	33
						414	114	109	104	99	94	2854	46	43	40	37	34
						424	116	111	106	101	96	2923	47	44	41	38	35
						434	118	113	108	103	98	2992	48	45	42	39	36
						444	119	114	109	104	99	3061	48	46	43	40	37
						454	121	116	111	106	101	3130	49	47	44	41	38
						464	123	118	113	108	103	3199	50	48	45	42	39
						474	124	119	114	109	104	3268	51	48	46	43	40
						484	126	121	116	111	106	3337	52	49	47	44	41
						494	127	122	117	112	107	3406	53	50	47	45	42
						504	129	124	119	114	109	3475	54	51	48	46	43
						514	131	126	121	116	111	3544	55	52	49	46	44
						524	132	127	122	117	112	3612	56	53	50	47	45
						534	134	129	124	119	114	3681	56	54	51	48	45

NOTE: Subcooling values calculated using High Stage.

Charging Procedure

1. Measure Discharge line pressure by attaching a gauge to the service port.
2. Measure the liquid line temperature by attaching a temperature sensing device to it.
3. Insulate the temperature sensing device so that the Outdoor Ambient doesn't affect the reading.
4. Refer to the required Subcooling in the table based on the model size and the Outdoor Ambient temperature.
5. Interpolate if the Outdoor ambient temperature lies in between the table values.
6. Find the Pressure Value in the table corresponding to the measured Pressure of the Compressor Discharge line.
7. Read across from the Pressure reading to obtain the liquid line temperature for a required Subcooling.
8. Add charge if the measured temperature is higher than the table value.
9. Remove charge if the measured temperature is lower than the table value.



50VR500263 REV. -



50VR500263 REV. -

50VR

Fig. 19 - Cooling Charging Chart

A170012

MAINTENANCE

To ensure continuing high performance, and to minimize the possibility of premature equipment failure, periodic maintenance must be performed on this equipment. This cooling unit should be inspected at least once each year by a qualified service person. To troubleshoot unit, refer to Table 12, Troubleshooting Chart.

NOTE TO EQUIPMENT OWNER: Consult your local dealer about the availability of a maintenance contract.

WARNING

PERSONAL INJURY AND UNIT DAMAGE HAZARD

Failure to follow this warning could result in personal injury or death and possible unit component damage.

The ability to properly perform maintenance on this equipment requires certain expertise, mechanical skills, tools and equipment. If you do not possess these, do not attempt to perform any maintenance on this equipment, other than those procedures recommended in the Owner's Manual.

50VR

WARNING

ELECTRICAL SHOCK AND FIRE HAZARD

Failure to follow these warnings could result in personal injury or death:

1. Turn off electrical power to the unit and install lockout tag before performing any maintenance or service on this unit.
2. Use extreme caution when removing panels and parts.
3. Never place anything combustible either on or in contact with the unit.

CAUTION

UNIT OPERATION HAZARD

Failure to follow this caution may result in equipment damage or improper operation.

Errors made when reconnecting wires may cause improper and dangerous operation. Label all wires prior to disconnecting when servicing.

The minimum maintenance requirements for this equipment are as follows:

1. Inspect air filter(s) each month. Clean or replace when necessary.
2. Inspect indoor coil, drain pan, and condensate drain each cooling season for cleanliness. Clean when necessary.
3. Inspect blower motor and wheel for cleanliness each cooling season. Clean when necessary.
4. Check electrical connections for tightness and controls for proper operation each cooling season. Service when necessary.
5. Ensure electric wires are not in contact with refrigerant tubing or sharp metal edges.

Air Filter

IMPORTANT: Never operate the unit without a suitable air filter in the return-air duct system. Always replace the filter with the same dimensional size and type as originally installed. See Table 1 for recommended filter sizes.

Inspect air filter(s) at least once each month and replace (throwaway-type) or clean (cleanable-type) at least twice during each cooling season and twice during the heating season, or whenever the filter becomes clogged with dust and lint.

Indoor Blower and Motor

NOTE: All motors are pre-lubricated. Do not attempt to lubricate these motors.

For longer life, operating economy, and continuing efficiency, clean accumulated dirt and grease from the blower wheel and motor annually.

WARNING

ELECTRICAL SHOCK HAZARD

Failure to follow this warning could result in personal injury or death.

Disconnect and tag electrical power to the unit before cleaning the blower motor and wheel.

To clean the blower motor and wheel:

1. Remove and disassemble blower assembly as follows:
 - a. Remove blower access panel (see Fig. 21).
 - b. Disconnect 5 pin plug and 4 pin plug from indoor blower motor. Remove capacitor if required.
 - c. On all units remove blower assembly from unit. Remove screws securing blower to blower partition and slide assembly out. Be careful not to tear insulation in blower compartment.
 - d. Ensure proper reassembly by marking blower wheel and motor in relation to blower housing before disassembly.
 - e. Loosen setscrew(s) that secures wheel to motor shaft, remove screws that secure motor mount brackets to housing, and slide motor and motor mount out of housing.
2. Remove and clean blower wheel as follows:
 - a. Ensure proper reassembly by marking wheel orientation.
 - b. Lift wheel from housing. When handling and/or cleaning blower wheel, be sure not to disturb balance weights (clips) on blower wheel vanes.
 - c. Remove caked-on dirt from wheel and housing with a brush. Remove lint and/or dirt accumulations from wheel and housing with vacuum cleaner, using soft brush attachment. Remove grease and oil with mild solvent.
 - d. Reassemble wheel into housing.
 - e. Reassemble motor into housing. Be sure setscrews are tightened on motor shaft flats and not on round part of shaft. Reinstall blower into unit.
 - f. Connect 5 pin plug and 4 pin plug to indoor blower motor. Reinstall capacitor if required.
 - g. Reinstall blower access panel (see Fig. 21).
3. Restore electrical power to unit. Start unit and check for proper blower rotation and motor speeds during cooling cycles.

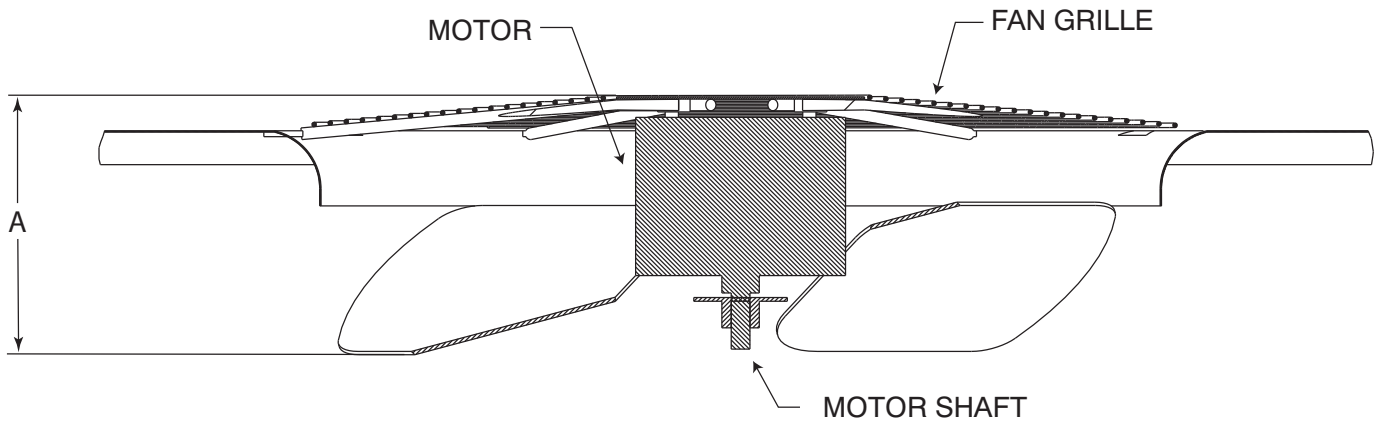

A08505

MAX DISTANCE BETWEEN TOP OF FAN GRILLE AND BOTTOM OF FAN BLADE

SIZE	"A"	
	IN.	MM
24	9.5	241
30	10.0	254
36	7.6	193
42	7.6	193
48	7.6	193
60	7.6	193

Fig. 20 - Fan Blade Position

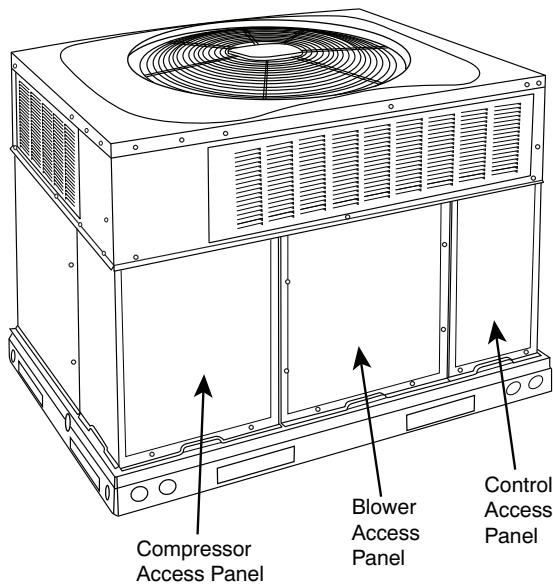

A09214

Fig. 21 - Unit Access Panels

Outdoor Coil, Indoor Coil, and Condensate Drain Pan

Inspect the condenser coil, evaporator coil, and condensate drain pan at least once each year.

The coils are easily cleaned when dry; therefore, inspect and clean the coils either before or after each cooling season. Remove all obstructions, including weeds and shrubs, that interfere with the airflow through the condenser coil.

Straighten bent fins with a fin comb. If coated with dirt or lint, clean the coils with a vacuum cleaner, using the soft brush attachment. Be careful not to bend the fins. If coated with oil or grease, clean the coils with a mild detergent and water solution. Rinse coils with clear water, using a garden hose. Be careful not to splash water on motors, insulation, wiring, or air filter(s). For best results, spray condenser coil fins from inside to outside the unit. On units with an outer and inner condenser coil, be sure to clean between the coils. Be sure to flush all dirt and debris from the unit base.

Inspect the drain pan and condensate drain line when inspecting the coils. Clean the drain pan and condensate drain by removing all foreign matter from the pan. Flush the pan and drain trough with clear water. Do not splash water on the insulation, motor, wiring, or air filter(s). If the drain trough is restricted, clear it with a "plumbers snake" or similar probe device.

OUTDOOR FAN

⚠ CAUTION

UNIT OPERATION HAZARD

Failure to follow this caution may result in damage to unit components.

Keep the condenser fan free from all obstructions to ensure proper cooling operation. Never place articles on top of the unit.

1. Remove 6 screws holding condenser grille and motor to top cover.
2. Turn motor/grille assembly upside down on top cover to expose the fan blade.
3. Inspect the fan blades for cracks or bends.
4. If fan needs to be removed, loosen the setscrew and slide the fan off the motor shaft.
5. When replacing fan blade, position blade as shown in Fig. 20.
6. Ensure that setscrew engages the flat area on the motor shaft when tightening
7. Replace grille.

Electrical Controls and Wiring

Inspect and check the electrical controls and wiring annually. Be sure to turn off the electrical power to the unit.

Remove access panels (see Fig. 21) to locate all the electrical controls and wiring. Check all electrical connections for tightness. Tighten all screw connections. If any smoky or burned connections are noticed, disassemble the connection, clean all the parts, restrip the wire end and reassemble the connection properly and securely.

50VR

After inspecting the electrical controls and wiring, replace the access panels (see Fig. 21). Start the unit, and observe at least one complete heating cycle and one complete cooling cycle to ensure proper operation. If discrepancies are observed in either or both operating cycles, or if a suspected malfunction has occurred, check each electrical component with the proper electrical instrumentation. Refer to the unit wiring label when making these checkouts.

NOTE: Refer to the heating and/or cooling sequence of operation in this publication as an aid in determining proper control operation

Refrigerant Circuit

Inspect all refrigerant tubing connections and the unit base for oil accumulations annually. Detecting oil generally indicates a refrigerant leak.

50VR

⚠ WARNING

EXPLOSION, SAFETY AND ENVIRONMENTAL HAZARD

Failure to follow this warning could result in personal injury, death or equipment damage.

This system uses Puron (R-410A) refrigerant which has higher operating pressures than R-22 and other refrigerants. No other refrigerant may be used in this system. Gauge set, hoses, and recovery system must be designed to handle Puron. If you are unsure, consult the equipment manufacturer.

If oil is detected or if low cooling performance is suspected, leak-test all refrigerant tubing using an electronic leak-detector, halide torch, or liquid-soap solution. If a refrigerant leak is detected, refer to Check for Refrigerant Leaks section.

If no refrigerant leaks are found and low cooling performance is suspected, refer to Checking and Adjusting Refrigerant Charge section.

Evaporator Airflow

The heating and/or cooling air-flow does not require checking unless improper performance is suspected. If a problem exists, be sure that all supply- and return-air grilles are open and free from obstructions, and that the air filter is clean. When necessary, refer to Indoor Airflow and Airflow Adjustments section to check the system airflow.

Metering Device

This unit uses 2 types of metering devices. The outdoor metering device is a fixed orifice and is contained in the brass hex-body in each liquid line feeding the outdoor coils. The indoor metering device is a TXV type device.

Pressure Switches

Pressure switches are protective devices wired into the control circuit (low voltage). They shut off compressor if abnormally high or low pressures are present in the refrigeration circuit. These pressure switches are specifically designed to operate with Puron (R-410A) systems. R-22 pressure switches must not be used as replacements for the Puron (R-410A) air conditioner.

Loss of Charge Switch

This switch is located on the liquid line and protects against low suction pressures caused by such events as loss of charge, low airflow across indoor coil, dirty filters, etc. It opens on a pressure drop at about 20 psig. If system pressure is above this, switch should be closed. To check switch:

NOTE: Because these switches are attached to refrigeration system under pressure, it is not advisable to remove this device for troubleshooting unless you are reasonably certain that a problem

exists. If switch must be removed, remove and recover all system charge so that pressure gauges read 0 psi (0 Pa). Never open system without breaking vacuum with dry nitrogen.

High-Pressure Switch

The high-pressure switch is located in the discharge line and protects against excessive condenser coil pressure. It opens at 650 psig (31.1 kPa). High pressure may be caused by a dirty condenser coil, failed fan motor, or condenser air recirculation.

To check switch:

1. Turn off all power to unit.
2. Disconnect leads on switch.
3. Apply ohmmeter leads across switch. You should have continuity on a good switch.

Copeland Scroll Compressor (Puron Refrigerant)

The compressor used in this product is specifically designed to operate with Puron (R-410A) refrigerant and cannot be interchanged.

The compressor is an electrical (as well as mechanical) device. Exercise extreme caution when working near compressors. Power should be shut off, if possible, for most troubleshooting techniques. Refrigerants present additional safety hazards.

⚠ WARNING

FIRE/EXPLOSION HAZARD

Failure to follow this warning could result in personal injury or death and/or property damage.

Wear safety glasses and gloves when handling refrigerants. Keep torches and other ignition sources away from refrigerants and oils.

The scroll compressor pumps refrigerant throughout the system by the interaction of a stationary and an orbiting scroll. The scroll compressor has no dynamic suction or discharge valves, and it is more tolerant of stresses caused by debris, liquid slugging, and flooded starts. The compressor is equipped with a noise reducing shutdown device and an internal pressure relief port. The pressure relief port is a safety device, designed to protect against extreme high pressure. The relief port has an operating range between 550 (26.3 kPa) and 625 (29.9 kPa) psig differential pressure.

Refrigerant

⚠ WARNING

EXPLOSION, ENVIRONMENTAL HAZARD

Failure to follow this warning could result in personal injury, death or equipment damage.

This system uses Puron (R-410A) refrigerant which has higher operating pressures than R-22 and other refrigerants. No other refrigerant may be used in this system. Gauge set, hoses, and recovery system must be designed to handle Puron. If you are unsure, consult the equipment manufacturer.

This system uses Puron (R-410A) refrigerant which has higher operating pressures than R-22 and other refrigerants. No other refrigerant may be used in this system. Gauge set, hoses, and recovery system must be designed to handle Puron. If you are unsure, consult the equipment manufacturer. Failure to use Puron compatible servicing equipment or replacement components may result in property damage or injury.

Compressor Oil

The Copeland scroll compressor uses 3MAF POE oil. If additional oil is needed, use Uniqema RL32-3MAF. If this oil is not available, use Copeland Ultra 32 CC or Mobil Arctic EAL22 CC.

This oil is extremely hygroscopic, meaning it absorbs water readily. POE oils can absorb 15 times as much water as other oils designed for HCFC and CFC refrigerants. Take all necessary precautions to avoid exposure of the oil to the atmosphere.

Servicing Systems on Roofs with Synthetic Materials

POE (polyolester) compressor lubricants are known to cause long term damage to some synthetic roofing materials. Exposure, even if immediately cleaned up, may cause embrittlement (leading to cracking) to occur in one year or more. When performing any service that may risk exposure of compressor oil to the roof, take appropriate precautions to protect roofing. Procedures which risk oil leakage include, but are not limited to, compressor replacement, repairing refrigerant leaks, replacing refrigerant components such as filter drier, pressure switch, metering device, coil, accumulator, or reversing valve.

Synthetic Roof Precautionary Procedure

1. Cover extended roof working area with an impermeable polyethylene (plastic) drip cloth or tarp. Cover an approximate 10 x 10 ft (3 x 3 m) area.
2. Cover area in front of the unit service panel with a terry cloth shop towel to absorb lubricant spills, prevent run-offs, and protect drop cloth from tears caused by tools or components.
3. Place terry cloth shop towel inside unit immediately under component(s) to be serviced and prevent lubricant run-offs through the louvered openings in the unit base.
4. Perform required service.
5. Remove and dispose of any oil contaminated material per local codes.

Liquid Line Filter Drier

The filter drier is specifically designed to operate with Puron. Use only factory-authorized components. Filter drier must be replaced whenever the refrigerant system is opened. When removing a filter drier, use a tubing cutter to cut the drier from the system. Do not unsweat a filter drier from the system. Heat from unsweating will release moisture and contaminants from drier into system.

Puron (R-410A) Refrigerant Charging

Refer to unit information plate and charging chart. Some R-410A refrigerant cylinders contain a dip tube to allow liquid refrigerant to flow from cylinder in upright position. For cylinders equipped with a dip tube, charge Puron units with cylinder in upright position and a commercial metering device in manifold hose. Charge refrigerant into suction-line.

Step 5 — System Information

Loss of Charge Switch

The loss of charge switch is a protective device wired into control circuit (low voltage). It shuts off the compressor if abnormally low pressures are present in the refrigeration circuit.

NOTE: Because these switches are attached to refrigeration system under pressure, it is not advisable to remove this device for troubleshooting unless you are reasonably certain that a problem exists. If switch must be removed, remove and recover all system charge so that pressure gauges read 0 psig. Never open system without breaking vacuum with dry nitrogen.

Check Defrost Thermostat

The defrost thermostat is usually located on the lowest liquid leaving circuit of the left condenser coil (see Fig. 22). The thermostat closes at 32°F (0°C) and opens at 65°F (18°C).

The defrost thermostat signals heat pump that conditions are right for defrost or that conditions have changed to terminate defrost. It is a thermally actuated switch clamped to outdoor coil to sense its temperature. Normal temperature range is closed at 32° ± 3°F (0 ± 1.7°C) and open at 65° ± 5°F (18 ± 2.8°C).

NOTE: The defrost thermostat must be located on the liquid side of the outdoor coil on the bottom circuit and as close to the coil as possible.

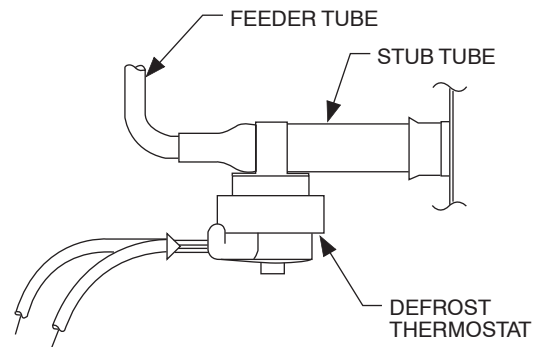

C99029

Fig. 22 - Defrost Thermostat

TROUBLESHOOTING

Refer to the Troubleshooting Chart (Table 12) for troubleshooting information.

START-UP CHECKLIST

Use the Start-Up Checklist at the back of this manual.

50VR

Table 12 – Troubleshooting Chart

SYMPTOM	CAUSE	REMEDY
Compressor and outdoor fan will not start	Power failure	Call power company
	Fuse blown or circuit breaker tripped	Replace fuse or reset circuit breaker
	Defective contactor, transformer or high-pressure, loss-of-charge or low-pressure switch	Replace component
	Insufficient line voltage	Determine cause and correct
	Incorrect or faulty wiring	Check wiring diagram and rewire correctly
	Thermostat setting too high	Lower thermostat setting below room temperature
Compressor will not start but condenser fan runs	Faulty wiring or loose connections in compressor circuit	Check wiring and repair or replace
	Compressor motor burned out, seized, or internal overload open	Determine cause Replace compressor
	Defective run/start capacitor, overload, start relay	Determine cause and replace
Three-phase scroll compressor (size 30-60 unit) has a low pressure differential	Scroll compressor is rotating in the wrong direction	Correct the direction of rotation by reversing the 3-phase power leads to the unit
Compressor cycles (other than normally satisfying thermostat)	Refrigerant overcharge or undercharge	Recover refrigerant, evacuate system, and recharge to capacities shown on rating plate
	Defective compressor	Replace and determine cause
	Insufficient line voltage	Determine cause and correct
	Blocked condenser	Determine cause and correct
	Defective run/start capacitor, overload or start relay	Determine cause and replace
	Defective thermostat	Replace thermostat
	Faulty condenser-fan motor or capacitor	Replace
Restriction in refrigerant system	Locate restriction and remove	
Compressor operates continuously	Dirty air filter	Replace filter
	Unit undersized for load	Decrease load or increase unit size
	Thermostat set too low	Reset thermostat
	Low refrigerant charge	Locate leak, repair, and recharge
	Mechanical damage in compressor	Replace compressor
	Air in system	Recover refrigerant, evacuate system, and recharge
	Condenser coil dirty or restricted	Clean coil or remove restriction
Excessive head pressure	Dirty air filter	Replace filter
	Dirty indoor or outdoor coil	Clean coil
	Refrigerant overcharged	Recover excess refrigerant
	Air in system	Recover refrigerant, evacuate system, and recharge
Head pressure too low	Low refrigerant charge	Check for leaks, repair and recharge
	Compressor IPR leaking	Replace compressor
	Restriction in liquid tube	Remove restriction
Excessive suction pressure	High heat load	Check for source and eliminate
	Compressor IPR leaking	Replace compressor
	Refrigerant overcharged	Recover excess refrigerant
Suction pressure too low	Dirty air filter	Replace filter
	Low refrigerant charge	Check for leaks, repair and recharge
	Metering device or low side restricted	Remove source of restriction
	Insufficient evaporator airflow	Increase air quantity Check filter—replace if necessary
	Temperature too low in conditioned area	Reset thermostat
	Outdoor ambient below 55°F (12.7°C)	Install low-ambient kit
	Filter drier restricted	Replace filter

50VR

PURON (R-410A) QUICK REFERENCE GUIDE

Puron refrigerant operates at 50–70 percent higher pressures than R-22. Be sure that servicing equipment and replacement components are designed to operate with Puron. Puron refrigerant cylinders are rose colored.

- Puron refrigerant cylinders manufactured prior to March 1, 1999, have a dip tube that allows liquid to flow out of cylinder in upright position.
Cylinders manufactured March 1, 1999 and later DO NOT have a dip tube and MUST be positioned upside down to allow liquid to flow.
- Recovery cylinder service pressure rating must be 400 psig. DOT 4BA400 or DOT BW400.
- Puron systems should be charged with liquid refrigerant. Use a commercial type metering device in the manifold hose.
- Manifold sets should be minimum 700 psig high-side and 180 psig low-side with 550 psig low-side retard.
- Use hoses with minimum 700 psig service pressure rating.
- Leak detectors should be designed to detect HFC refrigerant.
- Puron, as with other HFCs, is only compatible with POE oils.
- Vacuum pumps will not remove moisture from oil.
- Only use factory specified liquid-line filter driers with rated working pressures no less than 600 psig.
- Do not install a suction-line filter drier in liquid line.
- POE oils absorb moisture rapidly. Do not expose oil to atmosphere.
- POE oils may cause damage to certain plastics and roofing materials.
- Wrap all filter driers and service valves with wet cloth when brazing.
- A Puron liquid-line filter drier is required on every unit.
- Do not use an R-22 TXV.
- Never open system to atmosphere while it is under a vacuum.
- When system must be opened for service, break vacuum with dry nitrogen and replace filter driers.
- Always replace filter drier after opening system for service.
- Do not vent Puron into the atmosphere.
- Observe all warnings, cautions, and bold text.
- Do not leave Puron suction line driers in place for more than 72 hrs.

START-UP CHECKLIST

(Remove and Store in Job Files)

I. PRELIMINARY INFORMATION

MODEL NO.: _____

SERIAL NO.: _____

DATE: _____

TECHNICIAN: _____

II. PRESTART-UP (Insert check mark in box as each item is completed)

- VERIFY THAT ALL PACKING MATERIALS HAVE BEEN REMOVED FROM UNIT
- REMOVE ALL SHIPPING HOLD DOWN BOLTS AND BRACKETS PER INSTALLATION INSTRUCTIONS
- CHECK ALL ELECTRICAL CONNECTIONS AND TERMINALS FOR TIGHTNESS
- CHECK THAT INDOOR (EVAPORATOR) AIR FILTER IS CLEAN AND IN PLACE
- VERIFY THAT UNIT INSTALLATION IS LEVEL
- CHECK FAN WHEEL, AND PROPELLER FOR LOCATION IN HOUSING/ORIFICE AND SETSCREW TIGHTNESS

III. START-UP

ELECTRICAL

SUPPLY VOLTAGE _____

COMPRESSOR AMPS _____

INDOOR (EVAPORATOR) FAN AMPS _____

TEMPERATURES

OUTDOOR (CONDENSER) AIR TEMPERATURE _____ DB

RETURN-AIR TEMPERATURE _____ DB _____ WB

COOLING SUPPLY AIR _____ DB _____ WB

HEAT PUMP SUPPLY AIR _____

ELECTRIC HEAT SUPPLY AIR _____

PRESSURES

REFRIGERANT SUCTION _____ PSIG, SUCTION LINE TEMP* _____

REFRIGERANT DISCHARGE _____ PSIG, LIQUID TEMP† _____

- VERIFY REFRIGERANT CHARGE USING CHARGING CHARTS

* Measured at suction inlet to compressor

† Measured at liquid line leaving condenser.

50VR