



Installation, Start-Up and Service Instructions

CONTENTS

	Page
SAFETY CONSIDERATIONS	1
GENERAL	2
INSTALLATION	2
Step 1 — Complete Pre-Installation Checks	7
Step 2 — Rig and Place Unit	7
Step 3 — Install Evaporator (Supply) Ductwork ..	8
Step 4 — Install Return-Air Ductwork	8
Step 5 — Check Return-Air Filters	8
Step 6 — Make Condenser Connections	8
Step 7 — Install Condensate Drain Line	8
Step 8 — Complete Electrical Connections	9
Step 9 — Install Plenums (if Required)	12
START-UP	13
General	13
Compressor Rotation	19
Operating Sequence	19
SERVICE	19
Cleaning Evaporator Coil	19
Lubrication	19
Indoor Fan Adjustment	19
Pulley Alignment	19
Belt Tension Adjustment	19
Changing Fan Wheel	19
Fan Bearing Replacement	19
Concentric Alignment	20
Evaporator Motor Starter Setting (after Lockout/Tagout)	20
MAINTENANCE	21
Cleaning	21
Inspection	21
Condensate Drain	21
Checking System Charge	21
Evaporator-Fan Motor Removal	21
Pressure Relief Device	21
Current Protection Device	21
High and Low-Pressure Switches	21
Oil Charge	21
TROUBLESHOOTING	22
START-UP CHECKLIST	CL-1, CL-2

SAFETY CONSIDERATIONS

Installing, starting up, and servicing air-conditioning components and equipment can be dangerous. Only trained, qualified installers and service mechanics should install, start-up, and service this equipment.

When working on the equipment, observe precautions in the literature and on tags, stickers, and labels attached to the equipment. Follow all safety codes. Wear safety glasses and work gloves.

⚠ WARNING

Electrical shock can cause personal injury and death. Shut off all power to this equipment during installation. There may be more than one disconnect switch. Tag all disconnect locations to alert others not to restore power until work is completed.

⚠ CAUTION

Use care in handling, rigging, and setting bulky equipment. Personal injury could result.

⚠ WARNING

DO NOT USE TORCH to remove any component. System contains oil and refrigerant under pressure.

To remove a component, wear protective gloves and goggles and proceed as follows:

- a. Shut off electrical power to unit.
- b. Recover refrigerant to relieve all pressure from system using both high-pressure and low pressure ports.
- c. Traces of vapor should be displaced with nitrogen and the work area should be well ventilated. Refrigerant in contact with an open flame produces toxic gases.
- d. Cut component connection tubing with tubing cutter and remove component from unit. Use a pan to catch any oil that may come out of the lines and as a gage for how much oil to add to the system.
- e. Carefully unsweat remaining tubing stubs when necessary. Oil can ignite when exposed to torch flame.

Failure to follow these procedures may result in personal injury or death.

⚠ CAUTION

DO NOT re-use compressor oil or any oil that has been exposed to the atmosphere. Dispose of oil per local codes and regulations. DO NOT leave refrigerant system open to air any longer than the actual time required to service the equipment. Seal circuits being serviced and charge with dry nitrogen to prevent oil contamination when timely repairs cannot be completed. Failure to follow these procedures may result in damage to equipment.

GENERAL

Omnizone™ single package cooling units are designed to provide the flexibility required in replacement, renovation, and new construction. Units are available in 6 sizes from 5 tons to 20 tons.

The 50XCR units are remote, air-cooled condenser units, and are to be used with centrifugal or axial fan type remote air-cooled condensers. See Table 1. These vertical packaged units are fully piped and wired.

INSTALLATION

Omnizone 50XCR units are intended for indoor installation only. Determine building alterations required to run piping, wiring and ductwork. Follow dimensional drawings for ductwork, piping locations, electrical wiring and overall unit dimensions. Read all installation instructions before installing the unit.

See Fig. 1-5 for unit dimensions and refer to Table 2 for unit operating weights. Applicable installation codes may limit this cabinet to installation only in a single-story residence.

Table 1 — Condenser Usage

UNIT 50XCR	CONDENSER QUANTITY*												
	09XC SIZE						09AZ SIZE						
	06	08	12	14	16	24	06	08	12	14	16	24	
06	1						1						
08		1						1					
12			1						1				
14				1						1			
16					1							1	
24						1							1

*Either the 09XC or the 09AZ condenser can be used.

NOTE: Where there are no quantities of condensers listed, the combination is not recommended. See Application Data literature for more information on condenser combinations.

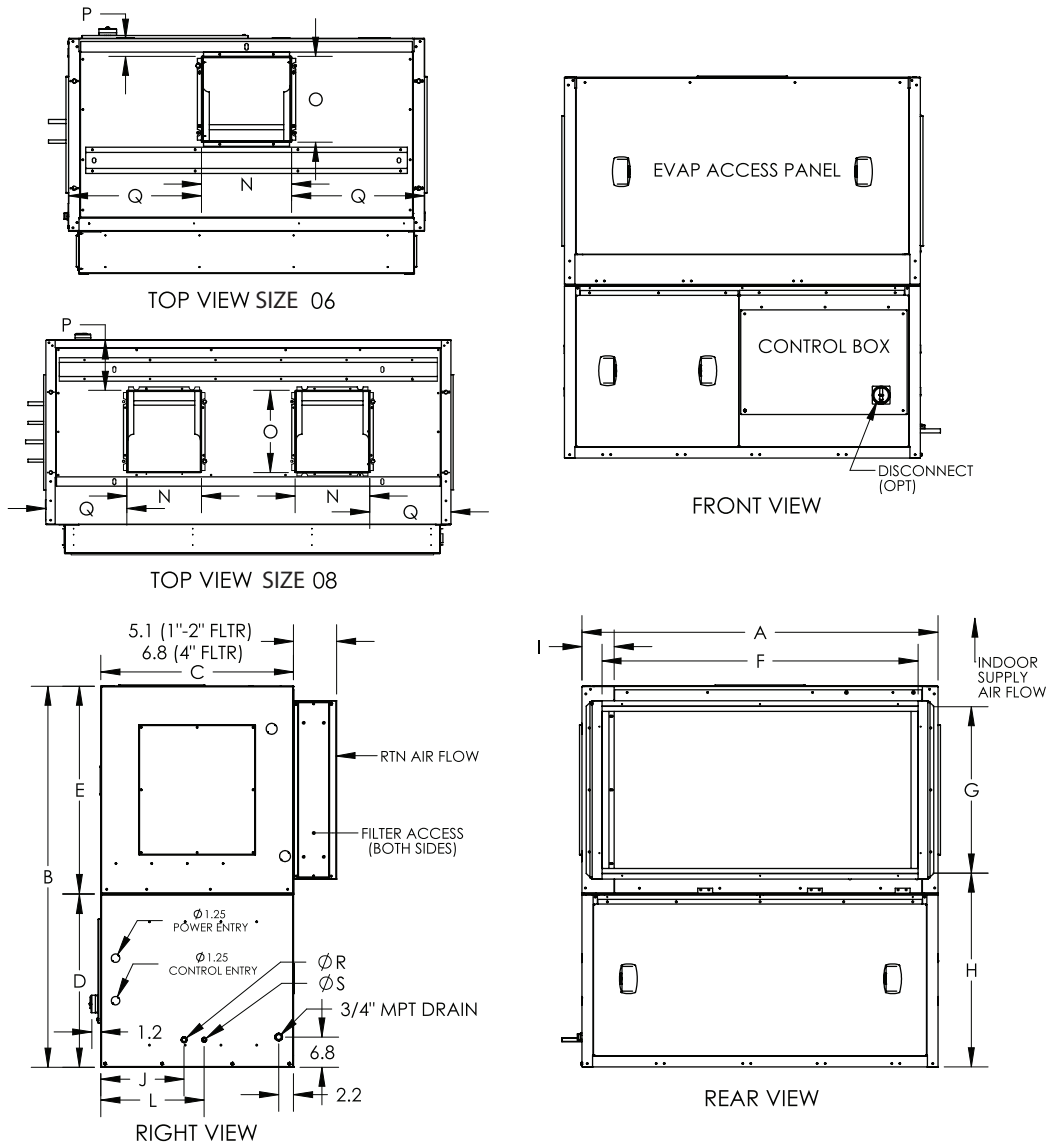

UNIT 50XCR	WIDTH	HEIGHT	DEPTH	COND SECTION	EVAP SECTION	EVAP RETURN DUCT				DISCH CONN	LIQUID CONN	EVAP SUPPLY DUCT (Blower Opening)				DISCH DIAMETER SWAGE (ID)	LIQUID DIAMETER SWAGE (ID)
	A	B	C	D	E	F	G	H	I	J	L	N	O	P	Q	R	S
06	53.1	57.0	29.0	25.8	31.0	47.2	24.8	28.9	4.8	12.4	15.4	13.4	12.8	2.7	19.8	0.625	0.5
08	53.1	57.0	29.0	25.8	31.0	47.2	24.8	28.9	4.8	12.4	15.4	13.4	12.8	2.7	7.6	0.625	0.5

NOTE: Dimensions are in inches.

Fig. 1 — Base Unit Dimensions — 50XCR06, 08 (Rear Return, Vertical Discharge)

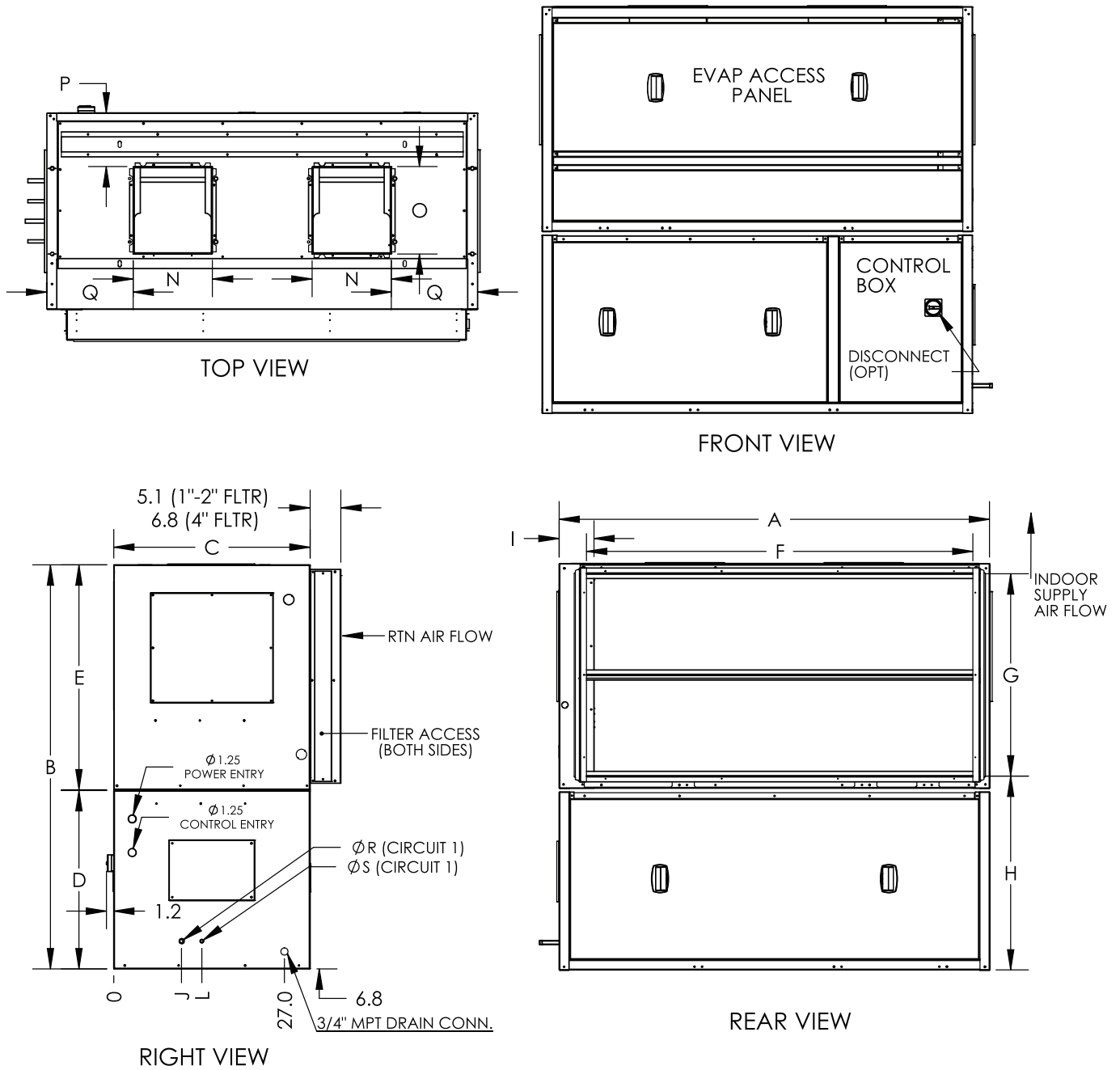

UNIT 50XCR	WIDTH		DEPTH	COND SECTION	EVAP SECTION	EVAP RETURN DUCT				DISCH CONN	LIQUID CONN	EVAP SUPPLY DUCT (Blower Opening)				DISCH DIAMETER SWAGE (ID)	LIQUID DIAMETER SWAGE (ID)
	A	B				F	G	H	I			N	O	P	Q		
12	68.0	64.0	31.2	28	35.5	61.1	31.8	29.4	5.5	11.1	13.9	12.5	13.8	8.5	13.6	0.875	0.625
14	68.0	64.0	31.2	28	35.5	61.1	31.8	29.4	5.5	11.1	13.9	12.5	13.8	8.5	13.6	0.875	0.625

NOTE: Dimensions are in inches.

Fig. 2 — Base Unit Dimensions — 50XCR12, 14 (Rear Return, Vertical Discharge)

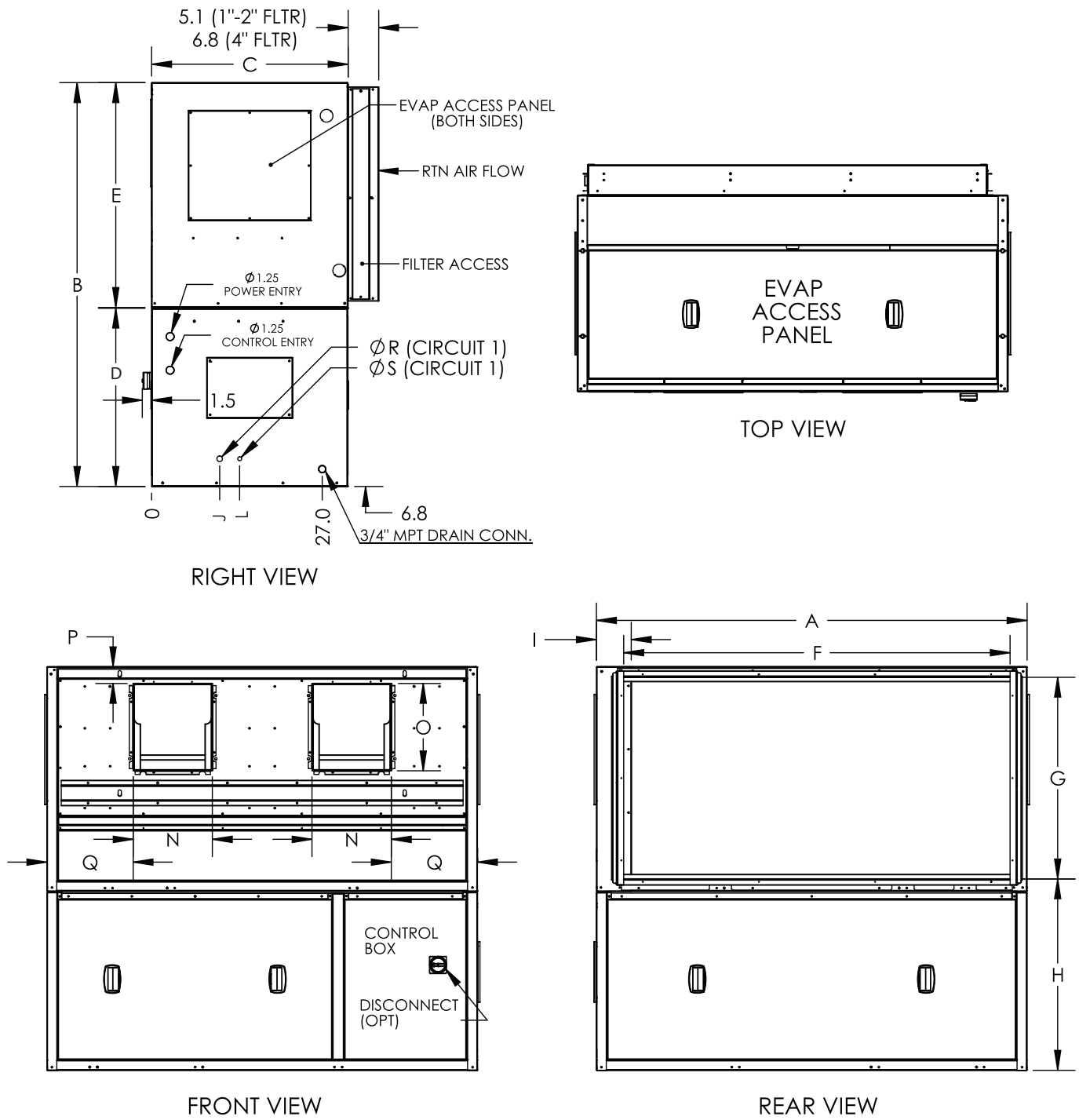

UNIT 50XCR	WIDTH	HEIGHT	DEPTH	COND SECTION	EVAP SECTION	EVAP RETURN DUCT				DISCH CONN	LIQUID CONN	EVAP SUPPLY DUCT (Blower Opening)				DISCH DIAMETER SWAGE (ID)	LIQUID DIAMETER SWAGE (ID)
	A	B	C	D	E	F	G	H	I	J	L	N	O	P	Q	R	S
12	68.0	64.0	31.2	28	35.5	61.1	31.8	29.4	5.5	11.1	13.9	12.5	13.8	2.7	13.6	0.875	0.625
14	68.0	64.0	31.2	28	35.5	61.1	31.8	29.4	5.5	11.1	13.9	12.5	13.8	2.7	13.6	0.875	0.625

NOTE: Dimensions are in inches.

Fig. 3 — Base Unit Dimensions — 50XCR12, 14 (Rear Return, Horizontal Discharge)

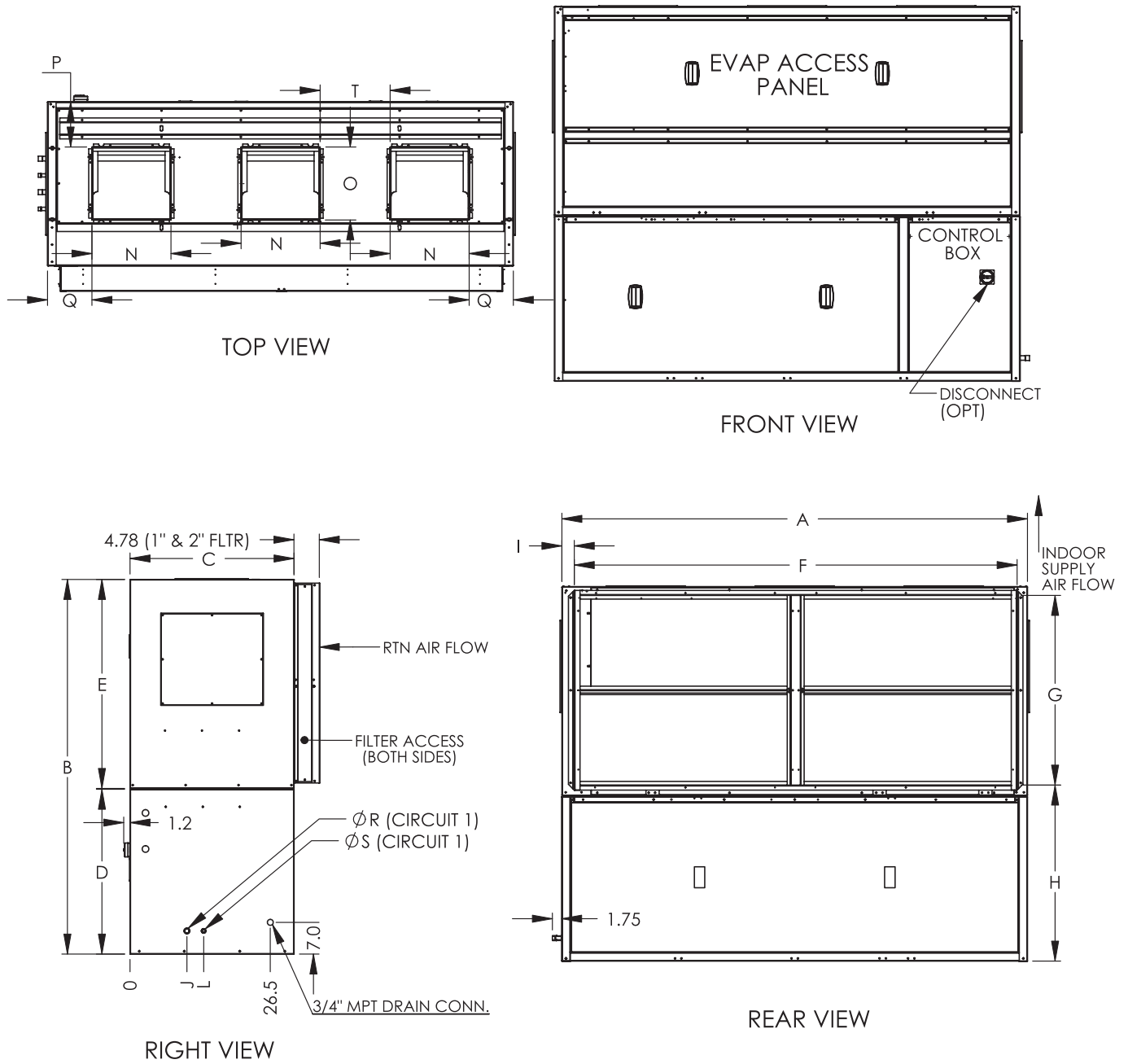

UNIT 50XCR	WIDTH	HEIGHT	DEPTH	COND SECTION	EVAP SECTION	EVAP RETURN DUCT				DISCH CONN	LIQUID CONN	EVAP SUPPLY DUCT (Blower Opening)					DISCH DIA SWAGE (ID)	LIQUID DIA SWAGE (ID)
	A	B	C	D	E	F	G	H	I	J	L	N	O	P	Q	T	R	S
16	88.0	66.7	31.2	31.2	35.5	83.7	33.8	32.3	3.1	10.8	13.9	12.5	13.8	8.5	13.5	11.7	1.125	0.625
24	88.0	70.8	31.2	31.2	39.5	83.7	37.8	32.3	2.3	10.8	13.9	14.9	13.8	8.6	8.3	13.2	1.125	0.625

NOTE: Dimensions are in inches.

Fig. 4 — Base Unit Dimensions — 50XCR16 (Rear Return, Vertical Discharge)

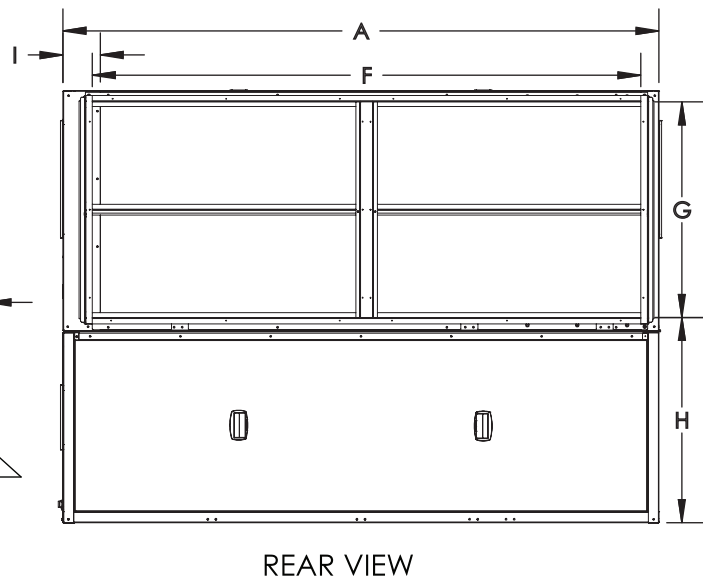
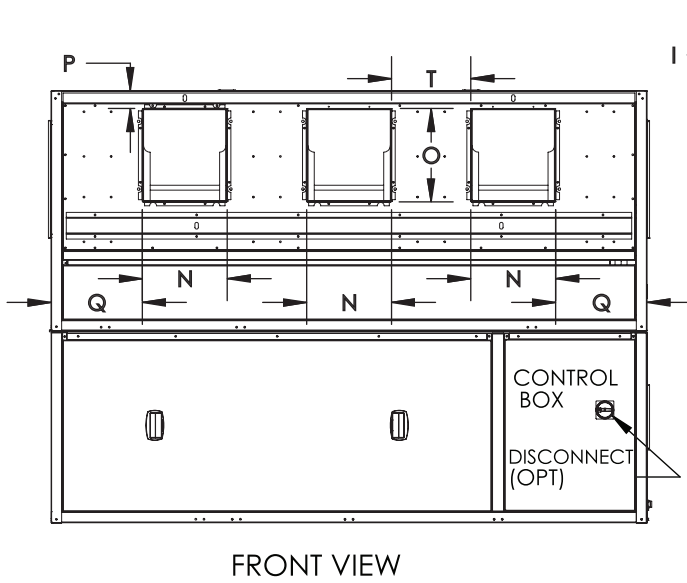
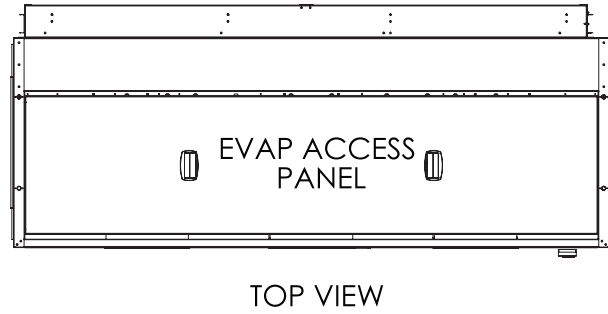
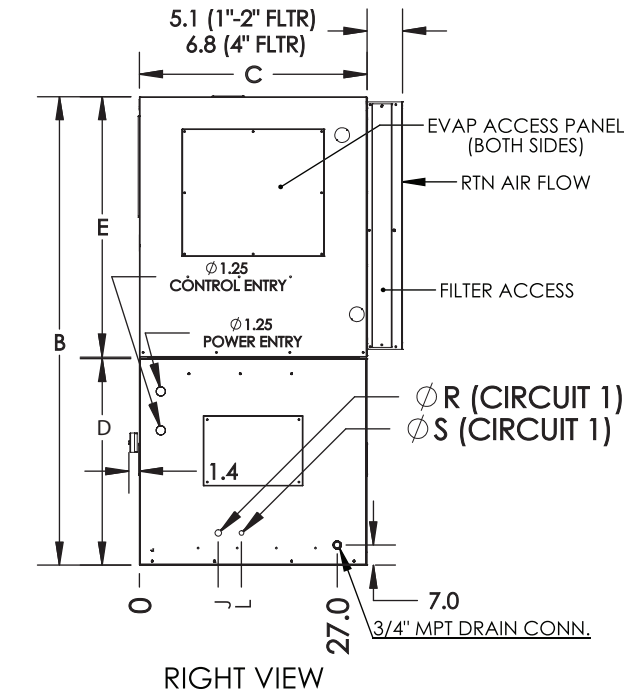

UNIT 50XCR	WIDTH	HEIGHT	DEPTH	COND SECTION	EVAP SECTION	EVAP RETURN DUCT				DISCH CONN	LIQUID CONN	EVAP SUPPLY DUCT (Blower Opening)				DISCH DIA SWAGE (ID)	LIQUID DIA SWAGE (ID)	
	A	B	C	D	E	F	G	H	I	J	L	N	O	P	Q	T	R	S
16	88.0	66.7	31.2	31.2	35.5	83.7	33.8	32.3	3.1	10.8	13.9	12.5	13.8	2.6	13.5	11.7	1.125	0.625
24	88.0	70.8	31.2	31.2	39.5	83.7	37.8	32.3	2.3	10.8	13.9	14.9	13.8	2.6	8.3	13.2	1.125	0.625

NOTE: Dimensions are in inches.

Fig. 5 — Base Unit Dimensions — 50XCR16, 24 (Rear Return, Horizontal Discharge)

Table 2 — Physical Data

UNIT 50XCR	5	7.5	10	12	15	20
UNIT OPERATING WEIGHT (lb)	600	799	1001	1079	1231	1629
COMPRESSOR	Scroll					
Compressor Model	ZPS60	ZPS67	ZP54/ZP49	ZP61/ZP57	ZP91/ZP67	ZP122/ZP91
Qty	1	1	2	2	2	2
Steps of Control	2	2	2	2	2	2
Operating Charge R-410A (lb)*	6.8	7.9	9.2	11.9	11.5	31.5
EVAPORATOR FAN	Adjustable, Belt Drive, Centrifugal Type					
Nominal Cfm	1750	2600	3500	4375	5000	7000
Cfm Range	1500 to 2500	2250 to 3750	3000 to 5000	3600 to 6000	4500 to 5500	6500 to 8000
Available Static (in. wg)	0 - 1.6	0 - 1.6	0 - 1.6	0 - 1.6	0 - 1.6	0 - 1.6
Evaporator Fan Size	110-10R	110-10R	120-9R	120-9R	120-9R	120-11R
Number of Evaporator Fans	1	2	2.0	2	3	3
Standard Speed Range (rpm)	576-782	712-949	656-875	712-949	564-836	664-936
Max. Allowable rpm	1600	1700	2000	2000	2000	2000
Belt Type	A41	BX41	BX51	BX51	BX51	BX66
Fan Pulley (Type)	AK89	BK65	BK70	BK65	BK67	BK95
Motor Pulley (Type)	1VL44	1VP34	1VP34	1VP34	1VP34	1VP50
Std Hp	1.0	1.0	1.0	1.5	1.5	3
Hp Range	1 - 2	1 - 2	1 - 3	1.5 - 5	1.5 - 5	3 - 7.5
Fan Shaft Size (in.)	0.75	1	1	1	1.1875	1.1875
Motor Shaft Size (in.)	0.875	0.875	0.875	0.875	0.875	1.125
Center Distance (in.) - Vertical	15.3	15.3	18.1	18.1	18.1	21.3
Center Distance (in.) - Horizontal	N/A	N/A	15.5	13	15.7	18.1
EVAPORATOR COIL	3/8-in. OD, Enhanced Copper Tube, Aluminum Fins					
Quantity Rows ... Fin/in.	3...15	4...15	3...15	4...15	4... 15	4... 15
Fin Block Size (H x L) (in.)	28x35	28x46	32x60	32x60	32x80	36x80
Face Area (sq ft)	6.8	8.9	13.3	13.3	17.7	20
RETURN AIR FILTERS						
Std 1 in., Throwaway	(2) 25 x 25	(2) 25 x 25	(8) 16 x 16	(8) 16 x 16	(8) 16 x 16 (2) 16 x 20	(4) 18 x 24 (4) 18 x 18
HIGH-PRESSURE SWITCH	Opens at 595 ± 10 psig; Closes at 443 ± 15 psig				Opens at 650± 10 psig; Closes at 500 ± 15 psig	
LOW-PRESSURE SWITCH	Opens at 53 ± 5 psig; Closes at 80 ± 7 psig					
CONDENSATE DRAIN LINE (in.)	1 at 3/4 MPT (Male Pipe Thread)					

LEGEND

MPT — Male Pipe Thread

* Refrigerant charge is for 50XCR only. Additional charge required for line sets and remote condenser unit.

Step 1 — Complete Pre-Installation Checks —

Examine unit for damage incurred during shipment. File claim immediately with transit company if damage is found. Check the shipment for completeness. Verify that the nameplate electrical requirements match the available power supply.

DO NOT place the unit in a horizontal position that would allow oil to drain into the top of the compressor. Do not allow refrigerant lines to come into contact with wiring or sharp objects or edges. Do not lift or move unit by putting pressure on refrigerant lines.

Step 2 — Rig and Place Unit —

Units are mounted on skids. Leave the unit on the skid until it is in the final position. While on the skid, the unit can be rolled, dragged or fork-lifted; *do not apply force to the unit*. Use a minimum of 3 rollers when rolling, and raise from above to remove the skid when unit is in the final position. See Fig. 6 for rigging details.

PLACING THE UNIT — The selected unit location should not be adjacent to an acoustically sensitive space. The best

locations for these units are mechanical rooms, near elevator shafts, near restrooms, near stairwells or other similar locations. Position the unit where large supply of outdoor air is available for the unit inlet. Be sure to leave enough space for the return air inlet access to the evaporator coil for cleaning and maintenance. Units located floor-to-floor should have a minimum of 10 ft between units to prevent recirculation of conditioned air. DO NOT locate units where they will recirculate conditioned air. This will cause increased head pressure which can cause units to trip on high pressure. See Fig. 1-5 and 7 for recommended unit clearances and locations.

Either provide inlet filters to protect the coils, or locate the unit in an area free from airborne dirt or other foreign material which could clog the coils.

The units are designed to pass through most 36-in. door openings. The filter rack may also be removed for additional clearance.

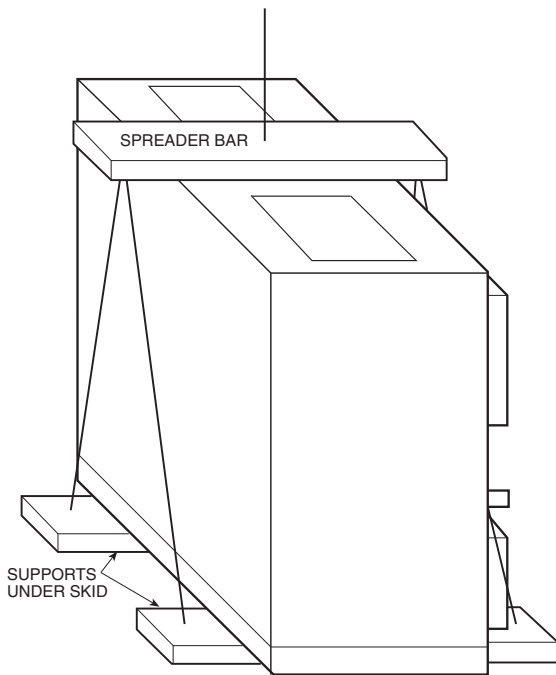
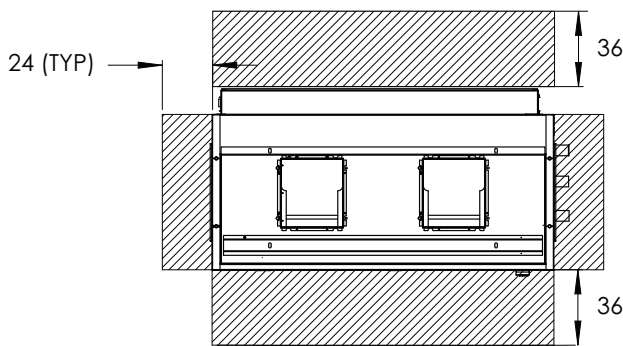

Fig. 6 — 50XCR Unit Rigging



NOTE: Dimensions are in inches.

Fig. 7 — Unit Clearances

→ **Step 3 — Install Evaporator (Supply) Ductwork** — The units should use a “pair of pants” configuration as shown in Fig. 8. Refer to the Carrier System Design Manual or ASHRAE standards for the recommended duct connection to unit with 2 or more fans.

A flexible canvas duct connector is recommended on both supply and return air sides of the units to be connected to the system ductwork.

All metal ductwork should be adequately insulated to avoid heat loss or gain and to prevent condensation from forming on the duct walls. Uninsulated ductwork is not recommended, as the unit's performance will be adversely affected.

Do not connect discharge ducts directly to the blower(s). The factory filter should be left in place on a free return system.

If the unit will be installed in a new installation, the duct system should be designed in accordance with the System Design Manual, Part 2 and with ASHRAE procedures for duct sizing. If the unit will be connected to an existing duct system,

check that the existing duct system has the capacity to handle the required airflow for the unit application at an acceptable system static pressure. If the existing duct system is too small, larger ductwork must be installed.

Units with two fans or more should have a properly designed “pair of pants” duct connection. (See Fig. 8.) Settling media may be required for uniform flow.

NOTE: Units with two or more fans should not be ducted separately.

An adequate straight length of ducting from the unit should be allowed before elbows are installed. See table below for recommended straight length.

50XCR UNIT	LENGTH (in.)	50XCR UNIT	LENGTH (in.)
06	36.5	14	36.7
08	36.5	16	36.7
12	36.7	24	40.0

Elbows should turn in the direction of fan rotation, if possible. Abrupt turns will generate air turbulence, and excessive noise. Turning vanes should be used in all short radius bends. Ensure that ducting does not obstruct access to the unit for routine servicing.

Step 4 — Install Return-Air Ductwork — Unit is designed for free return through the unit-mounted grille and filters. When installing ductwork and filter rack, use accepted ductwork installation procedures and do not hang the ductwork from the unit. Follow all applicable codes.

Step 5 — Check Return-Air Filters — Be sure filters shipped with unit are the correct size (see Table 2). Never operate unit without return-air filters in place.

Step 6 — Make Condenser Connections — Install air-cooled condenser in accordance with the installation instructions provided with condenser. Connection locations for liquid and refrigerant discharge service lines are shown in Fig. 1-5. Recommended line sizes are given in Table 3. Refer to Carrier System Design Manual, Part 3, for standard refrigerant piping techniques.

Remote condenser units are shipped with a holding charge of nitrogen. After refrigerant connections are made, release nitrogen, evacuate, leak test, and charge system as described in the Checking System Charge section on page 21.

Step 7 — Install Condensate Drain Line — The 50XCR unit has a drain connection for evaporator condensate. When connecting condensate drains from the unit to floor drains, sinks, or hoppers, connect drains downstream of trap to ensure that condensate does not drain back into the unit.

Make connections through the unit side panel. Some applications may require connection to either galvanized steel or copper drain pipe; consult local code requirements for details. See Fig. 9.

IMPORTANT: NEVER use pipe smaller than $\frac{3}{4}$ inches in the drain run.

Pitch drain pipe downward at a slope of at least $\frac{1}{4}$ -in. per ft for proper drainage. Provide tees plugged on one side for clean outs. Leave clearance for servicing, and observe all local sanitary codes.

The condensate trap should have a depth adequate to allow 3-in. of water in the trap (see Fig. 9) with the unit running.

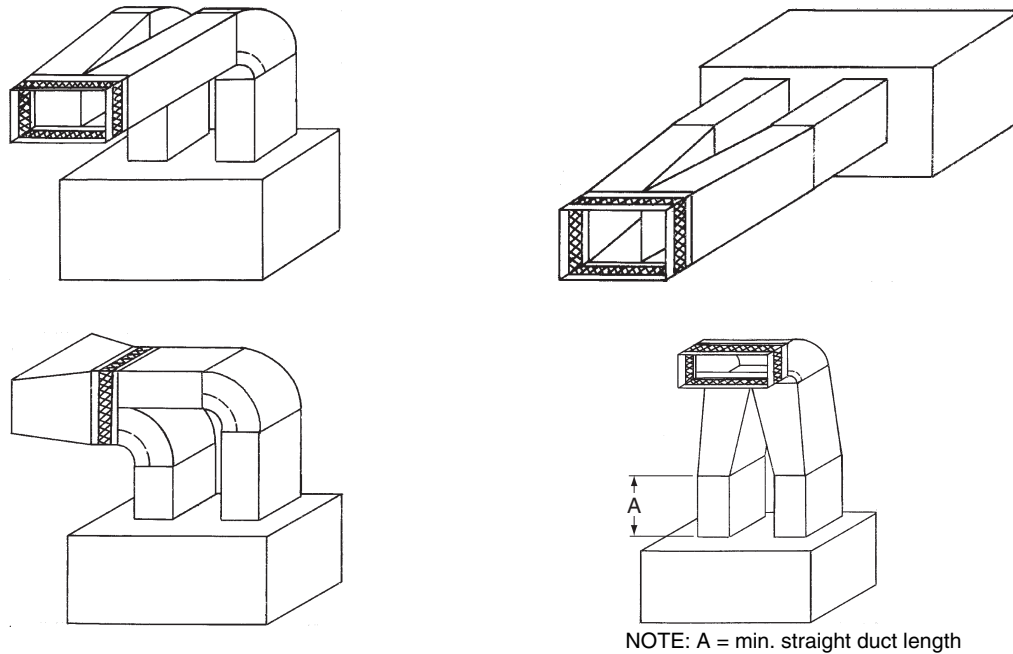

→ Fig. 8 — Typical Fan Discharge Connections for Multiple Fan Units

Table 3 — Recommended Line Sizes (in.)

50XC UNIT SIZE	CIRCUIT	LENGTH OF RUN (ft)									
		0 to 15		16 to 25		26 to 50		51 to 75		76 to 100	
		DIS	LIQ	DIS	LIQ	DIS	LIQ	DIS	LIQ	DIS	LIQ
06	1	5/8	1/2	7/8	1/2	7/8	1/2	7/8	5/8	7/8	5/8
08	1	5/8	1/2	7/8	1/2	7/8	1/2	7/8	5/8	7/8	5/8
12	1	7/8	5/8	7/8	5/8	1 1/8	5/8	1 1/8	5/8	1 1/8	5/8
14	1	7/8	5/8	7/8	5/8	1 1/8	5/8	1 1/8	5/8	1 1/8	5/8
16	2	1 1/8	5/8	1 1/8	5/8	1 1/8	5/8	1 3/8	7/8	7/8	7/8
24	2	1 1/8	5/8	1 1/8	5/8	1 3/8	5/8	1 3/8	7/8	1 1/8	7/8

LEGEND

- HG — Hot Gas (Refrigerant Discharge)
- LIQ — Liquid

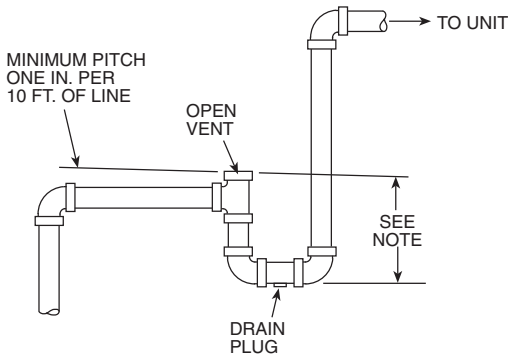

NOTE: Trap should be deep enough to offset maximum unit static difference. A 4-in. trap is recommended.

Fig. 9 — External Trap Condensate Drain

Step 8 — Complete Electrical Connections

GENERAL — Verify that nameplate electrical requirements match available power supply. Voltage at condenser must be within the minimum and maximum shown in Tables 4 and 5 and phases must be balanced within 2%. Contact local power company for line voltage corrections. Never operate a motor where a phase imbalance in supply voltage is greater than 2%.

Use the following formula to determine the percentage of voltage imbalance:

UNBALANCED 3-PHASE SUPPLY VOLTAGE — Use the following formula to determine the percent of voltage imbalance.

Percent Voltage Imbalance

$$= 100 \times \frac{\text{max voltage deviation from average voltage}}{\text{average voltage}}$$

Example: Supply voltage is 460-3-60.

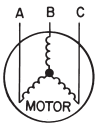

AB = 452 v
 BC = 464 v
 AC = 455 v

$$\begin{aligned} \text{Average Voltage} &= \frac{452 + 464 + 455}{3} \\ &= \frac{1371}{3} \\ &= 457 \end{aligned}$$

Determine maximum deviation from average voltage:

(AB) $457 - 452 = 5$ v

(BC) $464 - 457 = 7$ v

(AC) $457 - 455 = 2$ v

Maximum deviation is 7 v.

Determine percent of voltage imbalance:

$$\begin{aligned} \% \text{ Voltage Imbalance} &= 100 \times \frac{7}{457} \\ &= 1.53\% \end{aligned}$$

This amount of phase imbalance is satisfactory as it is below the maximum allowable 2%.

IMPORTANT: If supply voltage phase imbalance is more than 2%, contact your local electric utility company immediately.

Unit operation on improper line voltage or excessive phase imbalance may be considered abuse and any resulting damage may not be covered by Carrier warranty.

All wiring must be in accordance with local or NEC (National Electrical Code) regulations.

POWER WIRING — The units must have adequate overcurrent protection, fuses, or HACR (Heating, Air Conditioning and Refrigeration) breakers, according to the national and applicable local codes.

For field power connections, all main power wiring enters the unit through a factory-punched access hole under the control box. Attach power wires to the power connections on the main power terminal block in the unit control box. Be sure to install a ground wire.

CONTROL WIRING — All units require an accessory thermostat package to complete the unit control system. For a room-mounted thermostat, the thermostat may be mounted in an appropriate location in the conditioned space. Route the wires from the thermostat to the low voltage connection of the control box. Connect wires to the low voltage terminal block. See Fig. 10. The fan switch on the thermostat will control fan operations.

FREEZE PROTECTION THERMOSTAT — A freeze protection thermostat is standard and factory installed.

Table 4 — Electrical Data

UNIT 50XCR	V-PH-Hz	VOLTAGE RANGE		COMPRESSOR NO. 1		COMPRESSOR NO. 2	
		Min	Max	RLA	LRA	RLA	LRA
06	208/230-3-60	187	253	18.3	136	—	—
	460-3-60	414	506	8.8	66	—	—
	575-3-60	518	632	6.6	55	—	—
08	208/230-3-60	187	253	23.0	149	—	—
	460-3-60	414	506	11.0	75	—	—
	575-3-60	518	632	8.0	54	—	—
12	208/230-3-60	187	253	15.6	110	15.9	110
	460-3-60	414	506	7.8	52	7.1	52
	575-3-60	518	632	5.8	39	5.1	39
14	208/230-3-60	187	253	19.6	136	19.2	136
	460-3-60	414	506	8.2	66	8.7	66
	575-3-60	518	632	6.6	55	6.9	55
16	208/230-3-60	187	253	28.7	191	23.0	149
	460-3-60	414	506	13.3	100	11.0	75
	575-3-60	518	632	10.0	78	8.0	54
24	208/230-3-60	187	253	40.7	240	28.7	191
	460-3-60	414	506	19.3	140	13.3	100
	575-3-60	518	632	15.6	107	10.0	78

LEGEND

- FLA — Full Load Amps
- LRA — Locked Rotor Amps
- NEC — National Electrical Code
- RLA — Rated Load Amps

NOTES:

1. In compliance with NEC requirements for multimotor and combination load equipment (NEC Articles 430 and 440), the over-current protective device for the unit shall be fuse or HACR circuit breaker. Canadian units may be fuse or circuit breaker.
2. Wire sizing amps are a sum of 125% of the compressor RLA plus 100% of indoor fan motor FLA.
3. Motors are protected against primary single phasing condition.
4. Indoor-fan motors are 3-phase motors of same voltage as unit.



Table 5 — Fan Electrical Data

MOTOR CODE	HP	V-PH-Hz	VOLTAGE RANGE		FLA
			Min	Max	
B	0.50	208/230-3-60	187	253	1.8/2.2
		460-3-60	414	506	1.1
		575-3-60	518	632	0.9
C	0.75	208/230-3-60	187	253	2.5/2.6
		460-3-60	414	506	1.3
		575-3-60	518	632	1.0
D	1.00	208/230-3-60	187	253	3.2/3.2
		460-3-60	414	506	1.6
		575-3-60	518	632	1.1
E	1.50	208/230-3-60	187	253	4.6/4.8
		460-3-60	414	506	2.4
		575-3-60	518	632	1.6
F	2.00	208/230-3-60	187	253	6.0/5.8
		460-3-60	414	506	2.9
		575-3-60	518	632	2.1
G	3.00	208/230-3-60	187	253	9.2/8.6
		460-3-60	414	506	4.3
		575-3-60	518	632	3.4
H	5.00	208/230-3-60	187	253	14.5/13.6
		460-3-60	414	506	6.8
		575-3-60	518	632	5.4

LEGEND

- FLA — Full Load Amps



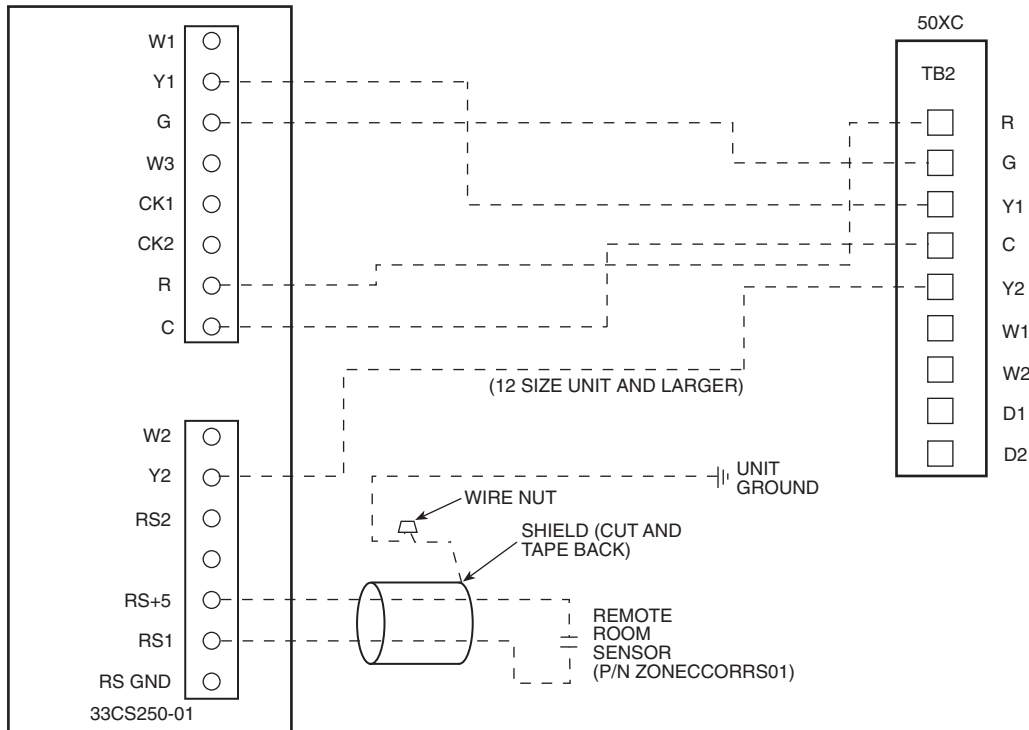

NOTE: Remote sensor is field-installed option.

Fig. 10 — Typical Thermostat Wiring Connections

Step 9 — Install Plenums (if Required) — The installation of 50XCR plenums is applicable to all vertical discharge 50XCR units.

IMPORTANT: Lockout and tagout all power supplies to equipment and controls prior to servicing unit. Follow all safety codes, including working at safe heights.

The following tools are required:

- $\frac{5}{16}$ -in. nut driver
- adequate lifting device
- utility knife
- safety glasses
- work gloves

Install as follows:

1. Apply $\frac{3}{4}$ -in. wide by $\frac{1}{4}$ -in. thick gasket tape supplied with unit to the bottom of mounting angles located on all four sides of the plenum. Ensure edge of gasket is even with inside edge of plenum walls and that there are no gaps in between insulation strips. See Fig. 11.
2. Using appropriate lifting device, lift plenum and place on top of 50XCR unit. Center plenum across both the width and depth directions.
3. Using a $\frac{5}{16}$ -in. nut driver, secure plenum mounting angles to 50XCR unit using 3 no. 10 $\frac{5}{8}$ -in. long screws provided with plenum. Install 3 screws along each plenum side and 5 screws along plenum front and rear mounting angles.
4. Adjust four-way deflection vanes as needed to ensure adequate airflow distribution.

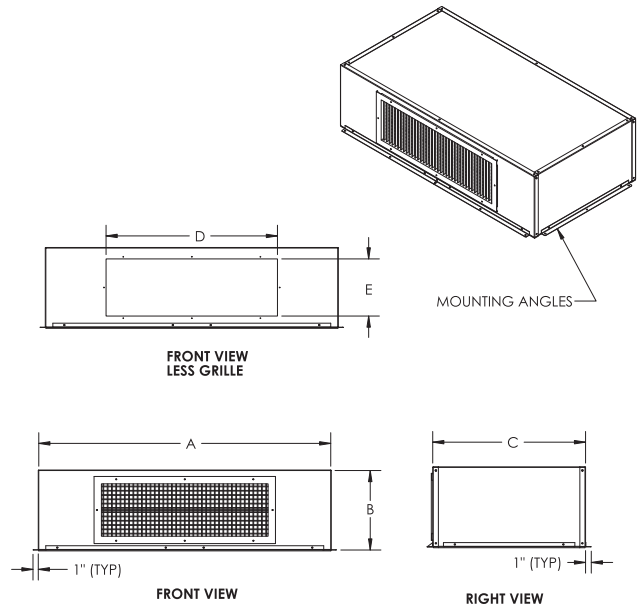

MODEL	UNIT SIZE	A	B	C	D	E	WGT (lb)
50XCR900-200A00	06	51.3	14.0	26.8	30.0	10.0	65
50XCR900-201A00	08	51.3	14.0	26.8	45.0	10.0	65
50XCR900-202A00	12	66.0	14.0	28.9	60.0	10.0	80
50XCR900-203A00	14	66.0	19.0	28.9	48.0	15.0	80
50XCR900-204A00	16	86.0	19.0	28.9	60.0	15.0	115
50XCR900-205A00	24	86.0	19.0	28.9	80.0	15.0	115

Fig. 11 — 50XC Plenum Unit

START-UP

⚠ CAUTION

To prevent injury, ensure that ducting or wire fan guards are installed on the condenser fan before starting the unit.

General — Complete the start up checklist on page CL-1 before attempting system start-up.

1. Set indoor thermostat system switch to OFF position.
2. Check all electrical connections, fuses, starter and pressure control resets.

3. Set selector switch on thermostat to the ON position. Adjust evaporator fan speed. If an airflow is not specified, use the nominal airflow from Table 2 and adjust the fan speed to compensate for actual job conditions. Use Tables 6-11 to determine proper fan speed.
4. Set thermostat at a setting below room temperature. Compressor will start. If compressor suction pressure does not drop and discharge pressure does not rise to normal levels at start-up, reverse any 2 compressor power leads and restore power to ensure compressor was not wired to run in reverse direction.
5. Set thermostat as desired.

Table 6 — Evaporator Fan Performance — 50XCR06 Units

CFM	ESP (in. wg)																			
	0.00		0.10		0.20		0.30		0.40		0.50		0.60		0.70		0.80		0.90	
	Rpm	Bhp	Rpm	Bhp	Rpm	Bhp	Rpm	Bhp	Rpm	Bhp	Rpm	Bhp	Rpm	Bhp	Rpm	Bhp	Rpm	Bhp	Rpm	Bhp
1500	477	0.19	542	0.24	603	0.30	660	0.36	714	0.43	766	0.50	816	0.58	864	0.66	910	0.74	954	0.83
1600	509	0.23	570	0.28	627	0.34	682	0.41	734	0.48	784	0.55	832	0.63	878	0.71	923	0.80	966	0.89
1700	540	0.27	598	0.33	653	0.40	705	0.46	755	0.54	803	0.61	849	0.69	894	0.78	937	0.87	979	0.96
1800	572	0.32	627	0.39	679	0.45	729	0.52	777	0.60	823	0.68	868	0.76	911	0.85	953	0.94	994	1.03
1900	604	0.38	656	0.45	706	0.52	754	0.59	800	0.67	844	0.75	887	0.83	929	0.92	970	1.01	1009	1.11
2000	636	0.44	685	0.51	733	0.58	779	0.66	823	0.74	866	0.83	908	0.91	948	1.01	988	1.10	1026	1.20
2100	668	0.51	715	0.58	760	0.66	804	0.74	847	0.82	888	0.91	929	1.00	968	1.09	1006	1.19	1044	1.29
2200	699	0.59	744	0.66	788	0.74	831	0.83	872	0.91	912	1.00	951	1.09	989	1.19	1026	1.29	1062	1.39
2300	731	0.67	774	0.75	816	0.83	857	0.92	897	1.01	935	1.10	973	1.20	1010	1.30	1046	1.40	1081	1.50
2400	763	0.76	804	0.85	845	0.93	884	1.02	922	1.11	960	1.21	996	1.31	1032	1.41	1067	1.51	1101	1.62
2500	795	0.86	835	0.95	873	1.04	911	1.13	948	1.22	985	1.32	1020	1.42	1055	1.53	1089	1.63	1122	1.74
2600	826	0.97	865	1.06	902	1.15	939	1.25	975	1.35	1010	1.45	1044	1.55	1078	1.66	1111	1.77	1144	1.88
2700	858	1.09	895	1.18	931	1.28	967	1.37	1002	1.47	1036	1.58	1069	1.68	1102	1.79	1134	1.91	—	—
2800	890	1.21	926	1.31	961	1.41	995	1.51	1029	1.61	1062	1.72	1094	1.83	1126	1.94	—	—	—	—
2900	922	1.35	956	1.45	990	1.55	1023	1.65	1056	1.76	1088	1.87	1119	1.98	—	—	—	—	—	—

CFM	ESP (in. wg)																			
	1.00		1.10		1.20		1.30		1.40		1.50		1.60		1.70		1.80		1.90	
	Rpm	Bhp	Rpm	Bhp	Rpm	Bhp	Rpm	Bhp	Rpm	Bhp	Rpm	Bhp	Rpm	Bhp	Rpm	Bhp	Rpm	Bhp	Rpm	Bhp
1500	997	0.92	1039	1.02	1080	1.12	1119	1.22	1158	1.33	1195	1.44	1232	1.55	1268	1.67	1303	1.79	1338	1.92
1600	1008	0.99	1049	1.08	1088	1.18	1127	1.29	1165	1.40	1201	1.51	1237	1.62	1273	1.74	1307	1.86	1341	1.99
1700	1020	1.05	1060	1.15	1098	1.26	1136	1.36	1173	1.47	1209	1.58	1244	1.70	1279	1.82	1313	1.94	—	—
1800	1033	1.13	1072	1.23	1110	1.33	1147	1.44	1183	1.55	1218	1.66	1252	1.78	1286	1.90	—	—	—	—
1900	1048	1.21	1086	1.31	1122	1.42	1158	1.53	1193	1.64	1228	1.75	1262	1.87	1295	1.99	—	—	—	—
2000	1063	1.30	1100	1.40	1136	1.51	1171	1.62	1205	1.73	1239	1.85	1272	1.97	—	—	—	—	—	—
2100	1080	1.39	1116	1.50	1151	1.61	1185	1.72	1219	1.84	1252	1.95	—	—	—	—	—	—	—	—
2200	1098	1.50	1132	1.61	1166	1.72	1200	1.83	1233	1.95	—	—	—	—	—	—	—	—	—	—
2300	1116	1.61	1150	1.72	1183	1.83	1216	1.95	—	—	—	—	—	—	—	—	—	—	—	—
2400	1135	1.73	1168	1.84	1201	1.96	—	—	—	—	—	—	—	—	—	—	—	—	—	—
2500	1155	1.86	1187	1.97	—	—	—	—	—	—	—	—	—	—	—	—	—	—	—	—
2600	1175	1.99	—	—	—	—	—	—	—	—	—	—	—	—	—	—	—	—	—	—
2700	—	—	—	—	—	—	—	—	—	—	—	—	—	—	—	—	—	—	—	—
2800	—	—	—	—	—	—	—	—	—	—	—	—	—	—	—	—	—	—	—	—
2900	—	—	—	—	—	—	—	—	—	—	—	—	—	—	—	—	—	—	—	—

LEGEND

Bhp — Brake Horsepower
ESP — External Static Pressure

NOTES:

1. Units are available with several motor hp options. Refer to Table 1.

2. Static pressure losses for any options or accessories must be applied to external static pressure before entering the fan performance table.
3. Interpolation is permitted; extrapolation is not.
4. Fan performance is based on 1 in. standard throwaway filter, unit casing, and wet DX (direct expansion) coil losses at sea level.

Table 7 — Evaporator Fan Performance — 50XCR08 Units

CFM	ESP (in. wg)																			
	0.00		0.10		0.20		0.30		0.40		0.50		0.60		0.70		0.80		0.90	
	Rpm	Bhp	Rpm	Bhp	Rpm	Bhp	Rpm	Bhp	Rpm	Bhp	Rpm	Bhp	Rpm	Bhp	Rpm	Bhp	Rpm	Bhp	Rpm	Bhp
2200	497	0.27	581	0.39	655	0.52	722	0.66	782	0.80	839	0.95	892	1.11	941	1.28	989	1.45	1034	1.62
2400	542	0.35	621	0.48	690	0.62	753	0.77	812	0.92	866	1.08	917	1.25	966	1.42	1012	1.60	1056	1.78
2600	587	0.45	660	0.59	726	0.74	787	0.89	843	1.06	895	1.22	945	1.40	992	1.58	1037	1.76	1080	1.95
2800	632	0.56	701	0.71	763	0.87	821	1.04	875	1.21	925	1.38	974	1.57	1019	1.75	1063	1.95	—	—
3000	677	0.69	742	0.85	801	1.02	856	1.19	908	1.37	957	1.56	1003	1.75	1048	1.95	—	—	—	—
3200	723	0.84	783	1.01	839	1.19	892	1.37	942	1.56	989	1.76	1034	1.96	—	—	—	—	—	—
3400	768	1.01	825	1.19	879	1.37	929	1.57	977	1.77	1023	1.97	—	—	—	—	—	—	—	—
3600	813	1.19	867	1.39	918	1.58	967	1.79	1013	2.00	—	—	—	—	—	—	—	—	—	—

CFM	ESP (in. wg)									
	1.00		1.10		1.20		1.30		1.40	
	Rpm	Bhp	Rpm	Bhp	Rpm	Bhp	Rpm	Bhp	Rpm	Bhp
2200	1077	1.80	1119	1.98	—	—	—	—	—	—
2400	1099	1.97	—	—	—	—	—	—	—	—
2600	—	—	—	—	—	—	—	—	—	—
2800	—	—	—	—	—	—	—	—	—	—
3000	—	—	—	—	—	—	—	—	—	—
3200	—	—	—	—	—	—	—	—	—	—
3400	—	—	—	—	—	—	—	—	—	—
3600	—	—	—	—	—	—	—	—	—	—

LEGEND

Bhp — Brake Horsepower
ESP — External Static Pressure

NOTES:

1. Units are available with several motor hp options. Refer to Table 2.

2. Static pressure losses for any options or accessories must be applied to external static pressure before entering the fan performance table.
3. Interpolation is permitted; extrapolation is not.
4. Fan performance is based on 1 in. standard throwaway filter, unit casing, and wet DX (direct expansion) coil losses at sea level.

Table 8 — Evaporator Fan Performance — 50XCR12 Units

CFM	ESP (in. wg)																			
	0.00		0.10		0.20		0.30		0.40		0.50		0.60		0.70		0.80		0.90	
	Rpm	Bhp	Rpm	Bhp	Rpm	Bhp	Rpm	Bhp	Rpm	Bhp	Rpm	Bhp	Rpm	Bhp	Rpm	Bhp	Rpm	Bhp	Rpm	Bhp
3000	381	0.26	434	0.33	492	0.41	533	0.51	614	0.63	674	0.77	730	0.93	783	1.10	831	1.29	877	1.47
3200	406	0.32	456	0.39	510	0.48	566	0.58	624	0.69	681	0.83	735	0.99	788	1.16	837	1.35	882	1.54
3400	432	0.39	478	0.46	528	0.55	581	0.65	635	0.76	689	0.90	742	1.05	793	1.22	841	1.41	887	1.61
3600	457	0.46	501	0.54	548	0.63	597	0.73	647	0.84	699	0.98	749	1.13	799	1.30	847	1.48	892	1.68
3800	483	0.54	524	0.62	568	0.72	614	0.82	661	0.93	710	1.06	758	1.21	806	1.38	852	1.56	897	1.76
4000	508	0.63	547	0.71	588	0.81	632	0.92	677	1.04	722	1.17	768	1.31	814	1.47	859	1.65	903	1.85
4200	533	0.73	570	0.82	609	0.92	650	1.03	693	1.15	736	1.28	780	1.42	823	1.58	867	1.76	910	1.95
4400	559	0.83	594	0.93	631	1.03	670	1.15	710	1.27	751	1.40	792	1.54	834	1.70	876	1.87	917	2.06
4600	584	0.95	618	1.05	653	1.16	690	1.28	728	1.40	767	1.53	806	1.68	846	1.83	886	2.01	926	2.19
4800	610	1.08	641	1.19	675	1.30	710	1.42	746	1.54	783	1.68	821	1.82	859	1.98	897	2.15	936	2.33
5000	635	1.22	666	1.33	698	1.45	731	1.57	766	1.70	801	1.84	837	1.98	873	2.14	910	2.31	946	2.49

CFM	ESP (in. wg)																			
	1.00		1.10		1.20		1.30		1.40		1.50		1.60		1.70		1.80		1.90	
	Rpm	Bhp	Rpm	Bhp	Rpm	Bhp	Rpm	Bhp	Rpm	Bhp	Rpm	Bhp	Rpm	Bhp	Rpm	Bhp	Rpm	Bhp	Rpm	Bhp
3000	919	1.66	958	1.85	994	2.04	1029	2.22	1061	2.40	1092	2.57	1122	2.74	1149	2.91	—	—	—	—
3200	925	1.74	965	1.94	1003	2.14	1039	2.34	1072	2.54	1104	2.73	1134	2.92	—	—	—	—	—	—
3400	931	1.82	972	2.03	1010	2.24	1047	2.45	1081	2.67	1114	2.88	—	—	—	—	—	—	—	—
3600	936	1.89	977	2.11	1016	2.33	1053	2.56	1089	2.78	—	—	—	—	—	—	—	—	—	—
3800	941	1.97	982	2.19	1022	2.42	1059	2.65	1095	2.89	—	—	—	—	—	—	—	—	—	—
4000	946	2.06	987	2.28	1027	2.51	1064	2.75	1101	3.00	—	—	—	—	—	—	—	—	—	—
4200	951	2.16	992	2.38	1031	2.61	1069	2.85	—	—	—	—	—	—	—	—	—	—	—	—
4400	958	2.27	998	2.49	1037	2.72	1074	2.96	—	—	—	—	—	—	—	—	—	—	—	—
4600	965	2.39	1004	2.61	1042	2.83	—	—	—	—	—	—	—	—	—	—	—	—	—	—
4800	974	2.53	1011	2.74	1049	2.97	—	—	—	—	—	—	—	—	—	—	—	—	—	—
5000	983	2.68	1020	2.89	—	—	—	—	—	—	—	—	—	—	—	—	—	—	—	—

LEGEND

Bhp — Brake Horsepower
ESP — External Static Pressure

NOTES:

1. Units are available with several motor hp options. Refer to Table 2.

2. Static pressure losses for any options or accessories must be applied to external static pressure before entering the fan performance table.
3. Interpolation is permitted; extrapolation is not.
4. Fan performance is based on 1 in. standard throwaway filter, unit casing, and wet DX (direct expansion) coil losses at sea level.

Table 9 — Evaporator Fan Performance — 50XCR14 Units

CFM	ESP (in. wg)																			
	0.00		0.10		0.20		0.30		0.40		0.50		0.60		0.70		0.80		0.90	
	Rpm	Bhp	Rpm	Bhp	Rpm	Bhp	Rpm	Bhp	Rpm	Bhp	Rpm	Bhp	Rpm	Bhp	Rpm	Bhp	Rpm	Bhp	Rpm	Bhp
3500	450	0.30	495	0.46	537	0.56	583	0.65	633	0.76	687	0.89	742	1.05	793	1.23	841	1.41	885	1.60
3700	476	0.35	519	0.53	558	0.64	600	0.73	646	0.84	696	0.96	748	1.12	799	1.29	847	1.48	892	1.68
3900	502	0.41	543	0.60	580	0.72	619	0.83	661	0.93	707	1.05	756	1.19	805	1.37	852	1.56	898	1.76
4100	527	0.48	566	0.68	602	0.82	639	0.93	678	1.03	720	1.15	765	1.29	811	1.45	858	1.64	903	1.84
4300	553	0.55	591	0.77	625	0.92	659	1.04	696	1.15	735	1.26	776	1.40	820	1.55	865	1.73	909	1.93
4500	579	0.63	615	0.87	648	1.03	681	1.15	715	1.27	751	1.39	789	1.52	830	1.67	872	1.84	915	2.03
4700	604	0.72	639	0.97	671	1.14	702	1.28	734	1.40	768	1.52	804	1.65	842	1.80	882	1.96	922	2.15
4900	630	0.81	664	1.08	694	1.27	724	1.41	755	1.55	786	1.67	820	1.80	855	1.94	892	2.10	931	2.28
5100	656	0.92	688	1.20	718	1.40	746	1.56	776	1.70	806	1.83	837	1.96	870	2.10	905	2.26	941	2.43
5300	682	1.03	713	1.33	741	1.54	769	1.71	797	1.86	826	2.00	855	2.14	886	2.28	919	2.43	953	2.59
5500	707	1.15	738	1.47	765	1.69	792	1.88	819	2.03	846	2.18	874	2.32	903	2.46	934	2.62	966	2.78
5700	733	1.28	763	1.61	789	1.85	815	2.05	841	2.22	867	2.37	894	2.52	921	2.67	950	2.82	980	2.98
5900	759	1.42	787	1.77	813	2.02	838	2.23	863	2.41	888	2.57	914	2.73	940	2.88	968	3.03	996	3.19
6100	784	1.57	812	1.93	838	2.20	862	2.42	886	2.62	910	2.79	934	2.95	960	3.11	986	3.27	1013	3.43

CFM	ESP (in. wg)																			
	1.00		1.10		1.20		1.30		1.40		1.50		1.60		1.70		1.80		1.90	
	Rpm	Bhp	Rpm	Bhp	Rpm	Bhp	Rpm	Bhp	Rpm	Bhp	Rpm	Bhp	Rpm	Bhp	Rpm	Bhp	Rpm	Bhp	Rpm	Bhp
3500	925	1.78	962	1.97	997	2.15	1030	2.32	1061	2.50	1090	2.67	1119	2.83	1146	3.00	1172	3.16	1198	3.32
3700	933	1.88	971	2.07	1007	2.27	1041	2.46	1072	2.65	1103	2.83	1131	3.01	1159	3.19	1186	3.37	1211	3.54
3900	940	1.97	979	2.17	1016	2.38	1051	2.59	1083	2.79	1114	2.99	1143	3.19	1172	3.38	1199	3.57	1225	3.76
4100	946	2.05	986	2.27	1024	2.49	1059	2.71	1093	2.93	1124	3.14	1154	3.35	1183	3.56	1211	3.77	1237	3.97
4300	951	2.15	992	2.37	1030	2.60	1067	2.83	1101	3.06	1133	3.29	1164	3.51	1194	3.73	1222	3.95	1249	4.17
4500	957	2.24	998	2.47	1036	2.71	1073	2.94	1108	3.18	1141	3.43	1173	3.66	1203	3.90	1232	4.14	1260	4.37
4700	963	2.35	1003	2.58	1042	2.81	1079	3.06	1115	3.31	1149	3.56	1181	3.81	1212	4.06	1241	4.31	1269	4.56
4900	970	2.48	1009	2.70	1047	2.93	1085	3.18	1121	3.43	1155	3.69	1188	3.95	1219	4.22	1249	4.48	1278	4.74
5100	978	2.62	1016	2.83	1053	3.06	1090	3.31	1126	3.56	1161	3.83	1194	4.10	1226	4.37	1257	4.64	1286	4.91
5300	988	2.78	1024	2.98	1060	3.20	1096	3.44	1132	3.70	1166	3.97	1200	4.24	1232	4.52	1263	4.80	—	—
5500	999	2.95	1033	3.15	1068	3.37	1103	3.60	1137	3.85	1172	4.11	1205	4.39	1238	4.67	1269	4.96	—	—
5700	1012	3.15	1044	3.34	1077	3.55	1110	3.77	1144	4.02	1178	4.28	1211	4.55	1243	4.83	—	—	—	—
5900	1025	3.36	1056	3.55	1087	3.75	1119	3.97	1152	4.20	1184	4.45	1217	4.72	—	—	—	—	—	—
6100	1040	3.60	1069	3.78	1099	3.97	1129	4.18	1160	4.41	1192	4.65	1223	4.91	—	—	—	—	—	—

LEGEND

Bhp — Brake Horsepower
ESP — External Static Pressure

NOTES:

1. Units are available with several motor hp options. Refer to Table 2.

2. Static pressure losses for any options or accessories must be applied to external static pressure before entering the fan performance table.
3. Interpolation is permitted; extrapolation is not.
4. Fan performance is based on 1 in. standard throwaway filter, unit casing, and wet DX (direct expansion) coil losses at sea level.

Table 10 — Evaporator Fan Performance — 50XCR16 Units

CFM	ESP (in. wg)																			
	0.00		0.10		0.20		0.30		0.40		0.50		0.60		0.70		0.80		0.90	
	Rpm	Bhp	Rpm	Bhp	Rpm	Bhp	Rpm	Bhp	Rpm	Bhp	Rpm	Bhp	Rpm	Bhp	Rpm	Bhp	Rpm	Bhp	Rpm	Bhp
4500	414	0.53	482	0.69	544	0.86	600	1.03	652	1.21	701	1.40	747	1.59	790	1.79	832	1.99	872	2.20
4750	437	0.63	502	0.79	561	0.97	615	1.15	666	1.34	714	1.53	758	1.73	801	1.94	842	2.15	881	2.37
5000	460	0.73	522	0.91	579	1.09	632	1.28	681	1.48	727	1.68	771	1.89	813	2.10	853	2.32	892	2.54
5250	483	0.85	542	1.04	597	1.23	648	1.43	696	1.63	741	1.84	784	2.06	825	2.28	865	2.50	902	2.73
5500	506	0.98	563	1.17	616	1.38	665	1.58	712	1.79	756	2.01	798	2.24	838	2.46	877	2.70	914	2.94
5750	529	1.12	584	1.33	635	1.54	682	1.75	728	1.97	771	2.20	812	2.43	851	2.67	889	2.91	926	3.15
6000	552	1.28	604	1.49	654	1.71	700	1.93	744	2.16	786	2.40	826	2.64	865	2.88	902	3.13	938	3.38
6250	575	1.45	625	1.67	673	1.90	718	2.13	761	2.37	802	2.61	841	2.86	879	3.11	916	3.37	951	3.63
6500	598	1.63	647	1.86	693	2.10	737	2.34	778	2.59	818	2.84	857	3.09	894	3.35	929	3.62	964	3.89
6750	621	1.83	668	2.07	713	2.32	755	2.57	796	2.82	835	3.08	872	3.34	909	3.61	944	3.89	978	4.16
7000	644	2.04	689	2.29	733	2.55	774	2.81	814	3.07	852	3.34	888	3.61	924	3.89	958	4.17	992	4.46
7250	667	2.27	711	2.53	753	2.80	793	3.07	832	3.34	869	3.62	905	3.90	940	4.18	973	4.47	1006	4.77
7500	690	2.52	732	2.79	773	3.06	812	3.34	850	3.62	886	3.91	922	4.20	956	4.49	989	4.79	—	—
7750	713	2.79	754	3.07	794	3.35	832	3.63	869	3.92	904	4.22	939	4.52	972	4.82	—	—	—	—
8000	736	3.07	776	3.36	814	3.65	852	3.94	887	4.24	922	4.55	956	4.85	—	—	—	—	—	—

CFM	ESP (in. wg)																			
	1.00		1.10		1.20		1.30		1.40		1.50		1.60		1.70		1.80		1.90	
	Rpm	Bhp	Rpm	Bhp	Rpm	Bhp	Rpm	Bhp	Rpm	Bhp	Rpm	Bhp	Rpm	Bhp	Rpm	Bhp	Rpm	Bhp	Rpm	Bhp
4500	910	2.42	947	2.64	983	2.86	1017	3.10	1051	3.33	1083	3.57	1115	3.82	1146	4.07	1176	4.33	1206	4.59
4750	919	2.59	955	2.82	991	3.05	1025	3.29	1058	3.53	1090	3.78	1121	4.03	1152	4.29	1182	4.55	1211	4.82
5000	929	2.77	965	3.01	999	3.25	1033	3.49	1066	3.74	1098	4.00	1129	4.26	1159	4.52	1188	4.79	—	—
5250	939	2.97	974	3.21	1008	3.46	1042	3.71	1074	3.97	1106	4.23	1136	4.49	1166	4.76	—	—	—	—
5500	950	3.18	984	3.43	1018	3.68	1051	3.94	1083	4.21	1114	4.47	1144	4.74	—	—	—	—	—	—
5750	961	3.40	995	3.66	1028	3.92	1061	4.19	1092	4.46	1123	4.73	—	—	—	—	—	—	—	—
6000	973	3.64	1006	3.91	1039	4.17	1071	4.45	1102	4.72	—	—	—	—	—	—	—	—	—	—
6250	985	3.90	1018	4.17	1050	4.44	1082	4.72	—	—	—	—	—	—	—	—	—	—	—	—
6500	998	4.16	1030	4.44	1062	4.73	—	—	—	—	—	—	—	—	—	—	—	—	—	—
6750	1011	4.45	1043	4.73	—	—	—	—	—	—	—	—	—	—	—	—	—	—	—	—
7000	1024	4.75	—	—	—	—	—	—	—	—	—	—	—	—	—	—	—	—	—	—
7250	—	—	—	—	—	—	—	—	—	—	—	—	—	—	—	—	—	—	—	—
7500	—	—	—	—	—	—	—	—	—	—	—	—	—	—	—	—	—	—	—	—
7750	—	—	—	—	—	—	—	—	—	—	—	—	—	—	—	—	—	—	—	—
8000	—	—	—	—	—	—	—	—	—	—	—	—	—	—	—	—	—	—	—	—

LEGEND

Bhp — Brake Horsepower
ESP — External Static Pressure

NOTES:

- Units are available with several motor hp options. Refer to Table 2.
- Static pressure losses for any options or accessories must be applied to external static pressure before entering the fan performance table.
- Interpolation is permitted; extrapolation is not.
- Fan performance is based on 1 in. standard throwaway filter, unit casing, and wet DX (direct expansion) coil losses at sea level.

Table 11 — Evaporator Fan Performance — 50XCR24 Units

CFM	ESP (in. wg)																			
	0.00		0.10		0.20		0.30		0.40		0.50		0.60		0.70		0.80		0.90	
	Rpm	Bhp	Rpm	Bhp	Rpm	Bhp	Rpm	Bhp	Rpm	Bhp	Rpm	Bhp	Rpm	Bhp	Rpm	Bhp	Rpm	Bhp	Rpm	Bhp
6,000	558	1.10	619	1.37	675	1.65	728	1.93	777	2.23	824	2.53	869	2.84	912	3.15	952	3.47	992	3.79
6,300	585	1.27	644	1.55	698	1.84	749	2.14	797	2.45	843	2.76	887	3.08	928	3.41	968	3.74	1007	4.08
6,600	613	1.46	669	1.76	722	2.06	771	2.37	818	2.69	862	3.02	905	3.35	945	3.69	985	4.03	1023	4.38
6,900	641	1.67	695	1.98	746	2.29	793	2.62	839	2.95	882	3.29	923	3.63	963	3.98	1002	4.34	1039	4.70
7,200	669	1.90	721	2.22	770	2.55	816	2.88	860	3.23	902	3.58	943	3.93	982	4.30	1019	4.66	1056	5.03
7,500	697	2.14	747	2.48	794	2.82	839	3.17	882	3.53	923	3.89	962	4.26	1000	4.63	1037	5.01	1073	5.39
7,800	725	2.41	773	2.76	818	3.11	862	3.48	904	3.85	944	4.22	982	4.60	1020	4.99	1056	5.38	1091	5.77
8,000	743	2.60	790	2.96	835	3.32	878	3.69	918	4.07	958	4.45	996	4.84	1033	5.23	1068	5.63	1103	6.04
8,300	771	2.90	817	3.27	860	3.65	901	4.03	941	4.42	979	4.82	1017	5.22	1053	5.63	1087	6.04	1121	6.45
8,600	799	3.23	843	3.61	885	4.00	925	4.40	964	4.80	1001	5.21	1038	5.62	1073	6.04	1107	6.47	1140	6.89
8,900	827	3.58	869	3.98	910	4.38	949	4.79	987	5.20	1024	5.62	1059	6.05	1093	6.48	1127	6.92	1160	7.36
9,200	855	3.96	896	4.36	935	4.78	973	5.20	1010	5.63	1046	6.06	1081	6.50	1114	6.94	1147	7.39	—	—
9,500	883	4.35	923	4.78	961	5.21	998	5.64	1034	6.08	1069	6.53	1103	6.98	1136	7.43	—	—	—	—
9,800	911	4.78	949	5.22	987	5.66	1023	6.11	1058	6.56	1092	7.02	1125	7.48	—	—	—	—	—	—
10,000	929	5.08	967	5.52	1004	5.97	1039	6.43	1074	6.89	1107	7.36	—	—	—	—	—	—	—	—

CFM	ESP (in. wg)																			
	1.00		1.10		1.20		1.30		1.40		1.50		1.60		1.70		1.80		1.90	
	Rpm	Bhp	Rpm	Bhp	Rpm	Bhp	Rpm	Bhp	Rpm	Bhp	Rpm	Bhp	Rpm	Bhp	Rpm	Bhp	Rpm	Bhp	Rpm	Bhp
6,000	1030	4.12	1067	4.46	1102	4.80	1137	5.14	1171	5.49	1203	5.84	1235	6.20	1267	6.56	1297	6.92	1327	7.29
6,300	1044	4.42	1080	4.76	1116	5.12	1150	5.47	1183	5.83	1215	6.20	1247	6.56	1278	6.94	1308	7.31	—	—
6,600	1059	4.73	1095	5.09	1129	5.45	1163	5.82	1196	6.19	1228	6.57	1259	6.95	1289	7.33	—	—	—	—
6,900	1075	5.06	1110	5.43	1144	5.81	1177	6.18	1209	6.57	1241	6.96	1272	7.35	—	—	—	—	—	—
7,200	1091	5.41	1125	5.79	1159	6.18	1191	6.57	1223	6.97	1254	7.36	—	—	—	—	—	—	—	—
7,500	1108	5.78	1141	6.18	1174	6.57	1206	6.98	1238	7.38	—	—	—	—	—	—	—	—	—	—
7,800	1125	6.17	1158	6.58	1190	6.99	1222	7.40	—	—	—	—	—	—	—	—	—	—	—	—
8,000	1137	6.45	1169	6.86	1201	7.28	—	—	—	—	—	—	—	—	—	—	—	—	—	—
8,300	1154	6.88	1187	7.30	—	—	—	—	—	—	—	—	—	—	—	—	—	—	—	—
8,600	1173	7.33	—	—	—	—	—	—	—	—	—	—	—	—	—	—	—	—	—	—
8,900	—	—	—	—	—	—	—	—	—	—	—	—	—	—	—	—	—	—	—	—
9,200	—	—	—	—	—	—	—	—	—	—	—	—	—	—	—	—	—	—	—	—
9,500	—	—	—	—	—	—	—	—	—	—	—	—	—	—	—	—	—	—	—	—
9,800	—	—	—	—	—	—	—	—	—	—	—	—	—	—	—	—	—	—	—	—
10,000	—	—	—	—	—	—	—	—	—	—	—	—	—	—	—	—	—	—	—	—

LEGEND

Bhp — Brake Horsepower
ESP — External Static Pressure

NOTES:

1. Units are available with several motor hp options. Refer to Table 2.

2. Static pressure losses for any options or accessories must be applied to external static pressure before entering the fan performance table.
3. Interpolation is permitted; extrapolation is not.
4. Fan performance is based on 1 in. standard throwaway filter, unit casing, and wet DX (direct expansion) coil losses at sea level.

Compressor Rotation — To determine whether or not compressor is rotating in the proper direction:

1. Connect service gages to suction and discharge pressure fittings.
2. Energize the compressor.
3. The suction pressure should drop and the discharge pressure should rise, as is normal on any start-up.
4. If the suction pressure does not drop and the discharge pressure does not rise to normal levels, the compressor may be rotating in the wrong direction.
5. Since the compressor and fan motors are connected in phase during production, it is likely that the evaporator and condenser fans are probably also rotating in the wrong direction.
6. Turn off power to the unit, lock and tag disconnect per standard safety procedures.
7. Reverse any two of the unit power leads.
8. Remove lock and tag per standard safety procedures and reapply power to the unit.
9. The suction and discharge pressure levels should now move to their normal start-up levels.

NOTE: When the compressor is rotating in the wrong direction, the unit makes an elevated level of noise and does not provide cooling.

Operating Sequence — All units require the addition of a thermostat accessory package to complete the control circuit. The sequence of operation may vary depending on which package is selected.

ROOM-MOUNTED THERMOSTAT — These units use an electronic thermostat mounted in the conditioned space.

FAN CIRCULATION — The indoor-fan motor is energized through G on the thermostat and the indoor-fan contactor is energized. This starts the indoor-fan motor (IFM). The fan will operate to provide continuous air circulation.

COOLING — The indoor fan will operate continuously or when the compressor runs, depending on the setting of the thermostat fan selector switch. When the thermostat closes (on a call for cooling Y1 on the thermostat), the control relay (CR), outdoor-fan contactor (OFC) and compressor contactor(s) (C1 and C2 on 50XCR12-16 units) close. The control relay will start the indoor fan if it is not already running. The compressor contactors will immediately start the first stage compressor(s).

A second stage on 50XCR12-16 units will close if additional cooling demand is required, and will then start the second-stage compressor. When the thermostat is satisfied, the second stage compressor will stop first, and then the first stage compressors will stop when cooling demand is satisfied.

ALL UNITS — The control circuit incorporates a current sensing lockout relay (Cycle-LOC™ device) that locks off the compressor(s) for 5 minutes when any safety device is activated (low or high pressure switches, or compressor internal overload). If any compressor safety device opens, the compressor will stop. High and low-pressure switches and compressor motor overload protectors will reset automatically when the condition which caused the device to trip has dropped below the reset condition. To reset the Cycle-LOC control device, manually turn the control power OFF, then back ON.

SERVICE

Cleaning Evaporator Coil — Do not use high-pressure water or air. Damage to fins may result. Clean coils with a vacuum cleaner, fresh water, compressed air, or a bristle brush (not wire). Backflush coil to remove debris. Commercial coil cleaners may also be used to help remove grease and dirt. Steam cleaning is NOT recommended.

Units installed in corrosive environments should be cleaned as part of a planned maintenance schedule. In this type of application, all accumulations of dirt should be cleaned off the coil.

Take care not to get water in the system ducts or unit insulation.

Lubrication — Fan motors have permanently lubricated bearings.

Indoor Fan Adjustment — To prevent personal injury, be sure wire fan guards (provided by customer) are secured in place over each fan discharge (or that fans are ducted) before starting the unit.

TO CHANGE FAN SPEED

1. Shut off unit power supply. Lock out power supply and tag disconnect locations.
2. Loosen fan belt by loosening fan motor belt adjusting bolts. Do not loosen fan motor mounting bracket from unit.
3. Loosen movable pulley flange setscrew (Fig. 12).
4. Screw movable flange toward fixed flange to increase fan speed and away from fixed flange to decrease speed. Increasing fan speed increases load on motor. Do not exceed maximum allowable fan speed or motor full load amps indicated on unit nameplate and in Table 5.
5. Set movable flange setscrew at nearest flat of pulley hub and tighten setscrew.
6. Check pulley alignment and belt tension adjustment as described below.
7. Check fan operation. Repeat above procedure as required.

Pulley Alignment — Shut off unit power supply. Lock out power supply and tag disconnect locations. Loosen fan motor pulley setscrews and slide fan pulley along fan shaft. Make angular alignment by loosening motor from mounting bracket (see Fig. 12). Check alignment with a straightedge.

Belt Tension Adjustment — Shut off unit power supply. Lock out power supply and tag disconnect locations. Loosen fan motor mounting plate bolts. Do not loosen motor mounting bracket from unit. Adjust belt tensioning bolt until proper belt tension is obtained.

Changing Fan Wheel — If a fan wheel should fail, it may be replaced as follows:

1. Shut off unit power supply. Lock out power supply and tag disconnect locations.
2. Remove belts from fan pulley.
3. Loosen locking collars on the fan bearings and set screws on the fan wheels.
4. Remove the shaft through the access panel on either side of the unit.
5. Remove the fan cut-off plate in the fan discharge.
6. Remove the fan wheel through the fan discharge opening.
7. Replace the wheel, and reverse Steps 1-5 above.

Fan Bearing Replacement — If a fan bearing fails, replace it as follows:

1. Shut off unit power supply. Lock out power supply and tag disconnect locations.
2. Remove belts from the fan pulley.
3. Support fan shaft.
4. Loosen locking collar on fan bearing.
5. Remove bearing from the shaft.
6. Install new bearing onto the shaft, and reverse Steps 1-3 above.

Concentric Alignment — Shaft and wheels must be concentrically centered with the venturi or air inlet of the fan housing (see Fig. 13).

Shaft bearings are supported by bearing supports (Fig. 14). If shaft and wheels are concentrically misaligned from shipping shock, it is possible to rebend the bearing support arms to the original positions. Replace the bearing support if it has extensive damage.

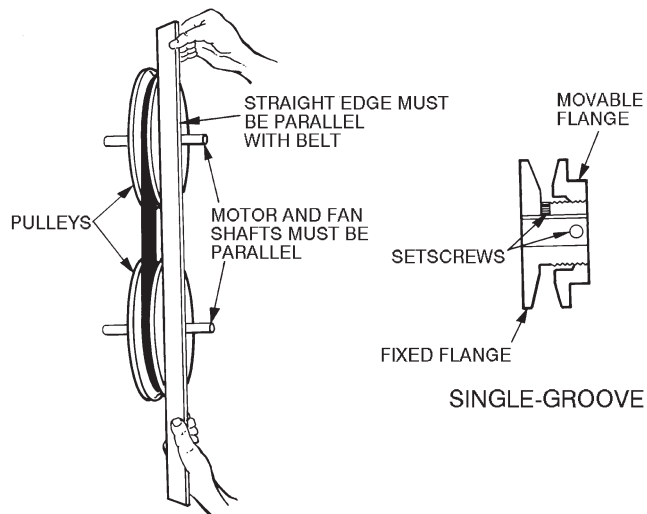

Fig. 12 — Fan Pulley Adjustments

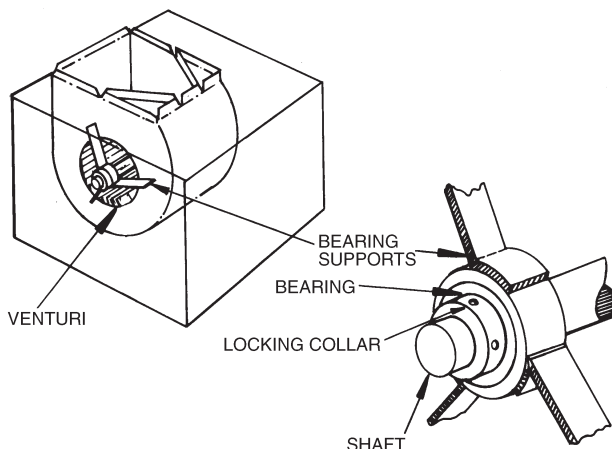

Fig. 14 — Fan Shaft Bearings

Evaporator Motor Starter Setting (after Lock-out/Tagout) — Motor starter is factory set. If starter is replaced in the field, use the following procedure to set:

1. On the starter, adjust the Motor Overload to match the **FLA Rating** of the installed motor by turning the Overload Setpoint wheel to the appropriate value. See Fig. 15. Evaporator and condenser motor FLA Ratings are listed in Table 12.
2. On the starter, turn the Motor Overload Reset wheel to **M-O** (referred to as Manual Reset).
3. On the starter, depress the Motor Overload Reset wheel (wheel also acts as reset button).
4. Turn the Power Switch/Disconnect Switch of the Start/Stop Station to the **ON** Position.

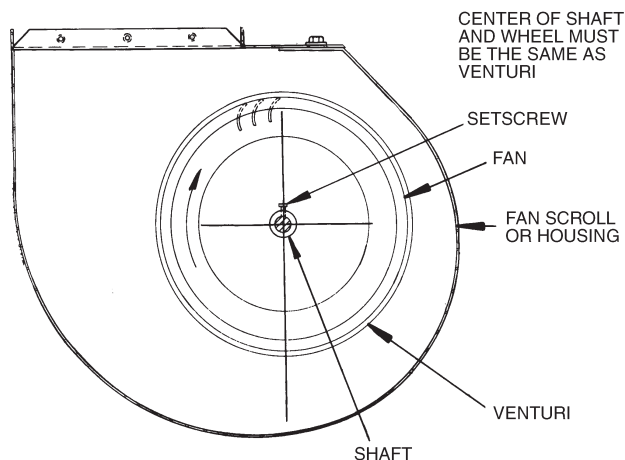

Fig. 13 — Concentric Alignment

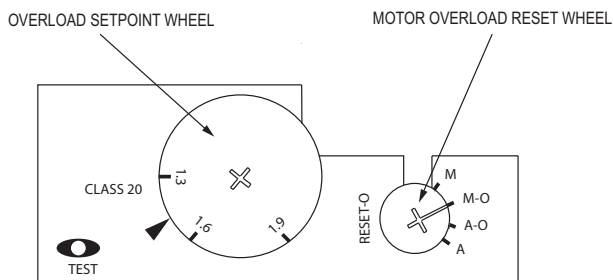

Fig. 15 — Motor Starter Setting

Table 12 — Evaporator and Condenser Motor Starter Settings

HP	208-230 V			460 V		575 V	
	Part Number	FLA		Part Number	FLA	Part Number	FLA
		208V	230V				
0.50	99MR0127BA020103	1.8	2.2	99MR0127BA020103	1.1	99MR0107BA020103	0.9
0.75	99MR0227BA020103	2.5	2.6	99MR0227BA020103	1.3	99MR0207BA020103	1.0
1.00	99MR0327BA250103	3.4	3.0	99MR0327BA250103	1.5	99MR0307BA250103	1.1
1.50	99MR0427BA260103	4.6	4.2	99MR0427BA260103	2.1	99MR0407BA260103	1.6
2.00	99MR0527BA260103	6.0	5.6	99MR0527BA260103	2.8	99MR0507BA260103	2.1
3.00	99MS0627BA27010B	9.2	8.6	99MS0627BA27010B	4.3	99MS0607BA27010B	3.4
5.00	99MS0727BA28010B	14.5	13.6	99MS0727BA28010B	6.8	99MS0707BA28010B	5.4
7.50	99MS0827BA29020B	21.5	19.4	99MS0827BA29020B	9.7	99MS0807BA29010B	7.5
10.00	99MS0927BA30010B	28.0	—	99MS0927BA30010B	12.6	99MS0907BA30010B	10.1

MAINTENANCE

Cleaning — The unit should be thoroughly cleaned inside and out. Frequency of cleaning will depend on unit location and area conditions. Drains must be kept free of dirt and trash. Coils can be cleaned with a stiff brush or vacuum cleaner. Coil can be reached through access panels.

Inspection — Check coil baffles for tight fit to prevent air from bypassing the coil. Check panels for air leakage, particularly those sealing the fan and coil compartments. Check for loose electrical connections, proper refrigerant charge, and refrigerant piping leaks.

Condensate Drain — The drain pan and trap should be cleaned at least twice per year. After cleaning, test the condensate drain for proper operation by pouring a bucket of water into the condensate drain pan. The water should flow out immediately and evenly.

Checking System Charge

NOTE: Condenser and evaporator airflow must be properly set before checking system charge.

The 50XCR units are shipped with full operating charge. If recharging is necessary:

1. Insert thermometer bulb in insulating rubber sleeve on liquid line near filter drier. Use a digital thermometer for all temperature measurements. DO NOT use a mercury or dial-type thermometer.
2. Connect refrigerant pressure gage to discharge line near compressor.
3. After unit condition have stabilized, read head pressure on discharge line gage.

NOTE: Operate unit a minimum of 15 minutes before checking charge.

4. From standard Pressure-Temperature chart for R-410A, find equivalent saturated condensing temperature.
5. Read liquid line temperature on thermometer; then subtract from saturated condensing temperature. The difference equals subcooling temperature.
6. Compare the subcooling temperature with the normal temperature listed in Table 13. If the measured liquid line temperature does not agree with the required liquid line temperature, ADD refrigerant to raise the temperature or REMOVE refrigerant (using standard practices) to lower the temperature (allow a tolerance of $\pm 3^{\circ}\text{F}$).

Example:

Head pressure (from gage) 416.4 psig
 Saturated condensing temp (from chart) 120°F
 Liquid line temp (from thermometer) 100°F
 Subcooling (by subtraction) 20°F

Table 13 — Subcooling Temperature

UNIT 50XCR	SUBCOOLING*
06	20°
08	17°
12-14	21°
16	18°
24	25°

*Saturated condensing temperature at compressor minus liquid line temperature.

⚠ WARNING

To prevent personal injury, wear safety glasses and gloves when handling refrigerant. Do not overcharge system — this can cause compressor flooding.

NOTE: Do not vent or depressurize unit refrigerant to atmosphere. Remove and recover refrigerant following accepted practices.

Evaporator-Fan Motor Removal

⚠ CAUTION

Before attempting to remove fan motors or motor mounts, place a piece of plywood over evaporator coils to prevent coil damage.

1. Shut off unit main power supply. Lock out power supply and tag disconnect locations.
2. Loosen bolts on mounting bracket so that fan belt can be removed.
3. Disconnect motor power wires from motor terminals.
4. Remove the 4 motor mounting bolts from bottom of motor.
5. Remove motor. Rest motor securely on a high platform such as a step ladder. Do not allow motor to hang by its power wires.

Pressure Relief Device — All units are equipped with a fusible-plug type safety relief device on the refrigerant tubing. The relief setting is 210°F.

Current Protection Device — All units are equipped with a current-sensing lockout relay on each circuit. This device will lock out the compressor after any safety trip (high-pressure switch, low-pressure switch, or internal overload of the compressor) for 5 minutes. Check reason for lockout before resetting the device. To reset, turn the thermostat system switch to OFF, then back to COOL position.

High and Low-Pressure Switches — The high-pressure switch is located on the compressor discharge line. The low-pressure switch is located on the suction line.

Oil Charge — All units are factory charged with oil (see Table 2 for compressor model number). It is not necessary to add oil unless the compressor is removed from the unit. If additional oil is needed, do not use mineral oils. Only synthetic oils are satisfactory.

TROUBLESHOOTING

Refer to Table 14 to determine the possible cause of the problem and the associated procedure necessary to correct it. See Fig. 16-18 for typical wiring schematic.

Table 14 — Troubleshooting Procedure

PROBLEM	POSSIBLE CAUSE	CORRECTION PROCEDURE
Unit will not Start	Loss of unit power	Check power source. Check fuses, circuit breakers, disconnect switch. Check electrical contacts.
	Unit voltage not correct	Check and correct.
	Open fuse	Check for short circuit in unit.
	Open protection device	Check relays, contacts, pressure switches.
	Unit or motor contactor out of order	Test and replace if necessary.
Fan does not Operate	Contactor or relay overload or out of order	Test and replace if necessary.
	Motor defective	Test and replace if necessary.
	Broken belt	Replace belt.
	Loose electrical contact	Tighten contact.
Compressor is Noisy, but will Start	Under voltage	Check and correct.
	Defect in compressor motor	Replace compressor.
	Missing phase	Check and correct.
	Compressor seized	Check and replace if necessary.
Compressor Starts, but does not Continue to Run	Compressor or contact defect	Test and replace if necessary.
	Unit is not properly charged	Check and correct any leaks. Adjust refrigerant charge.
	Unit is oversized	Check heat load calculation.
	Compressor is overloaded	Check protection device and replace. Check for missing phase. Check TXV. Check temperature in suction discharge line.
Unit is Noisy	Compressor noise	Check TXV and replace if necessary. Check internal noise.
	Tube vibration or condenser water problem	Check and correct.
	Unit panel or part vibrating	Check and tighten appropriate part.
Unit Runs Continuously, but has Low Capacity	Unit is undersized	Check heat load calculation.
	Low refrigerant or noncondensing gas present	Check for leaks and add refrigerant or gas as necessary. Replace refrigerant if noncondensing gas present.
	Compressor defect	Check pressure and amps. Replace if necessary.
	Insufficient flow of refrigerant in evaporator	Check filter drier and replace if necessary. Check TXV and adjust or replace if necessary. Check position of TXV bulb and equalizer.
	Low airflow	Check filters, and clean or replace as necessary. Check coils, and clean as necessary. Check for restrictions in ductwork. Check fan rotation and adjust. Check fan motor. Check belts for wear.
	Oil in evaporator	Drain evaporator.
High Discharge Pressure	Low airflow in condenser	Check fan rotation. Check motor, and replace if necessary. Check belts, and replace if necessary. Check coils, and clean if necessary.
	Scale in condenser coil	Clean condenser.
	High temperature in condenser air or air recirculation	Check for short circuit of air. Check water supply installation.
	Overcharged	Check and recover excess charge. Adjust subcooling.
	Water connections reversed.	Verify and correct.
	Noncondensing gas present	Verify and correct. Replace refrigerant.

LEGEND

TXV — Thermostatic Expansion Valve

Table 14 — Troubleshooting Procedure (cont)

PROBLEM	POSSIBLE CAUSE	CORRECTION PROCEDURE
Discharge Pressure too Low	Outdoor temperature too low	Install low-ambient control.
	Condenser airflow too high	Check and adjust.
	Low charge	Check for and repair leaks and add refrigerant as necessary.
	Compressor fault	Check suction and discharge pressure.
Suction Pressure too Low	Discharge pressure is low	See Discharge Pressure Too Low section of this table above.
	Low thermal load	Check building load.
	Low refrigerant	Check for and repair leaks and add refrigerant as necessary.
	Low airflow in evaporator	Clean filter. Remove scale. Check for blockage in ducts. Check fan rotation. Check motor operation. Check belts.
	Low refrigerant flow in evaporator	Check for obstruction in filter drier. Check for obstruction in TXV. Check super heating. Check position of TXV bulb and equalizer.
Suction Pressure too High	High thermal load	Check design conditions.
	Compressor defect	Check pressures, and replace if necessary.
Condensate Water Leaks	Defective connection	Check and correct.
	Blocked drain	Clean drain pan.
	Drain lines incorrect	Check and correct.

LEGEND

TXV — Thermostatic Expansion Valve

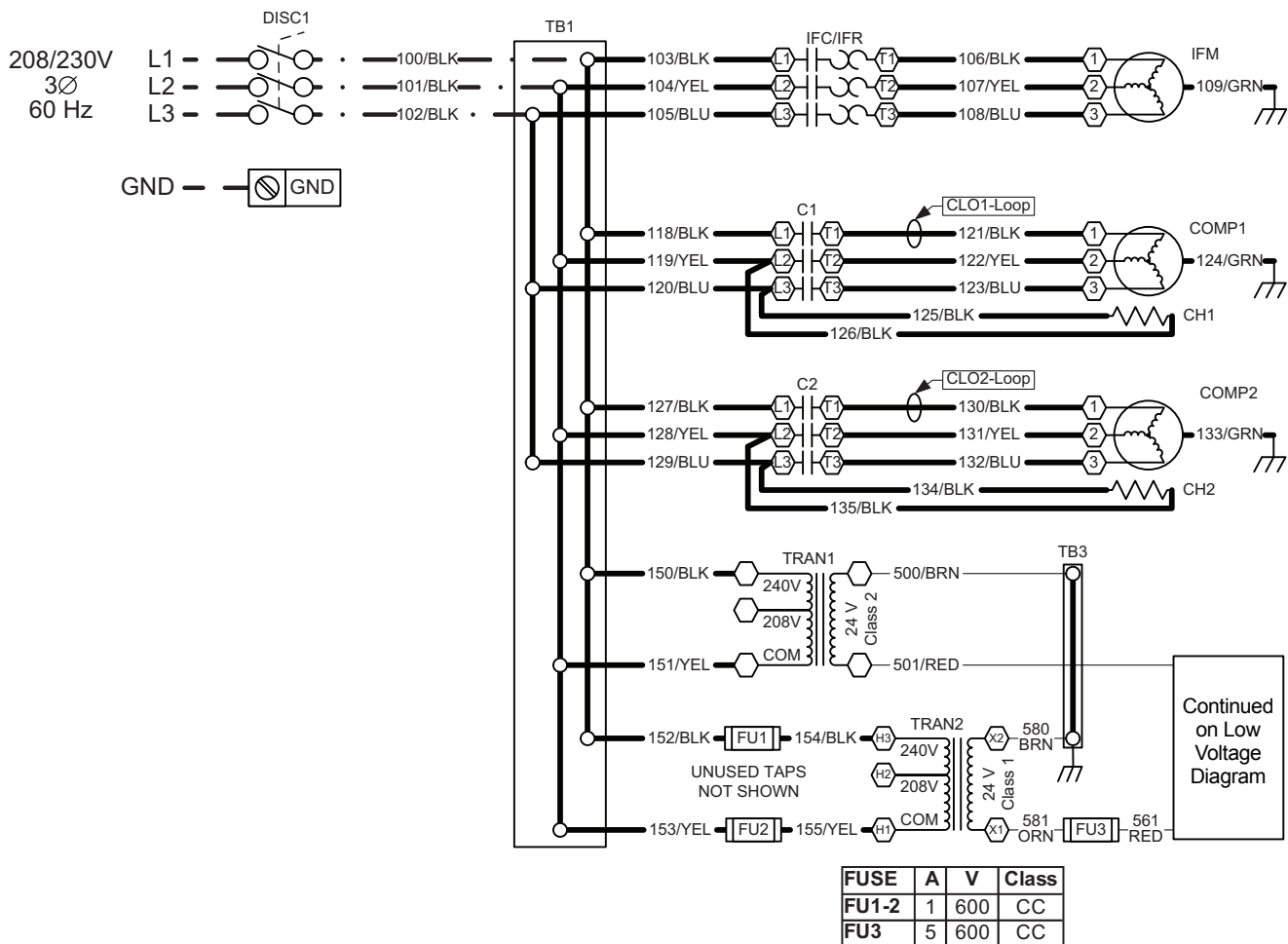

Fig. 16 — Typical Wiring Schematic (50XCR12-24, 208/230-3-60 Units Shown)

LEGEND AND NOTES FOR FIG. 16-18

LEGEND	
C — Compressor Contactor	OFM — Outdoor-Fan Motor
CH — Crankcase Heater	OFR — Outdoor-Fan Relay
CLO — Compressor Lockout	SAT — Supply Air Thermistor
COMP — Compressor	SV — Solenoid Valve
CR — Control Relay	TB — Terminal Block
DISC — Disconnect	TRAN — Transformer
FR — Fan Relay	VFD — Variable Frequency Drive
FRZ — Freeze Protection	Terminal Block Connection
GND — Ground	Marked Terminal
HPS — High Pressure Switch	Unmarked Terminal
HR — Heat Relay	Splice
IFC — Indoor-Fan Contactor	Factory Wiring
IFM — Indoor-Fan Motor	Field Power Wiring
IFR — Indoor-Fan Relay	
LPS — Low Pressure Switch	
LLT — Liquid Line Temperature	
OFC — Outdoor-Fan Contactor	

NOTES:

1. Fan motors are inherently thermally protected.
2. Three-phase motors are protected under primary single phase conditions.
3. Use conductors suitable for at least 194°F (90°C) when replacing factory wiring.
4. Use copper conductors only.
5. Wiring for field power supply must be rated at 165°F (75°C) minimum.

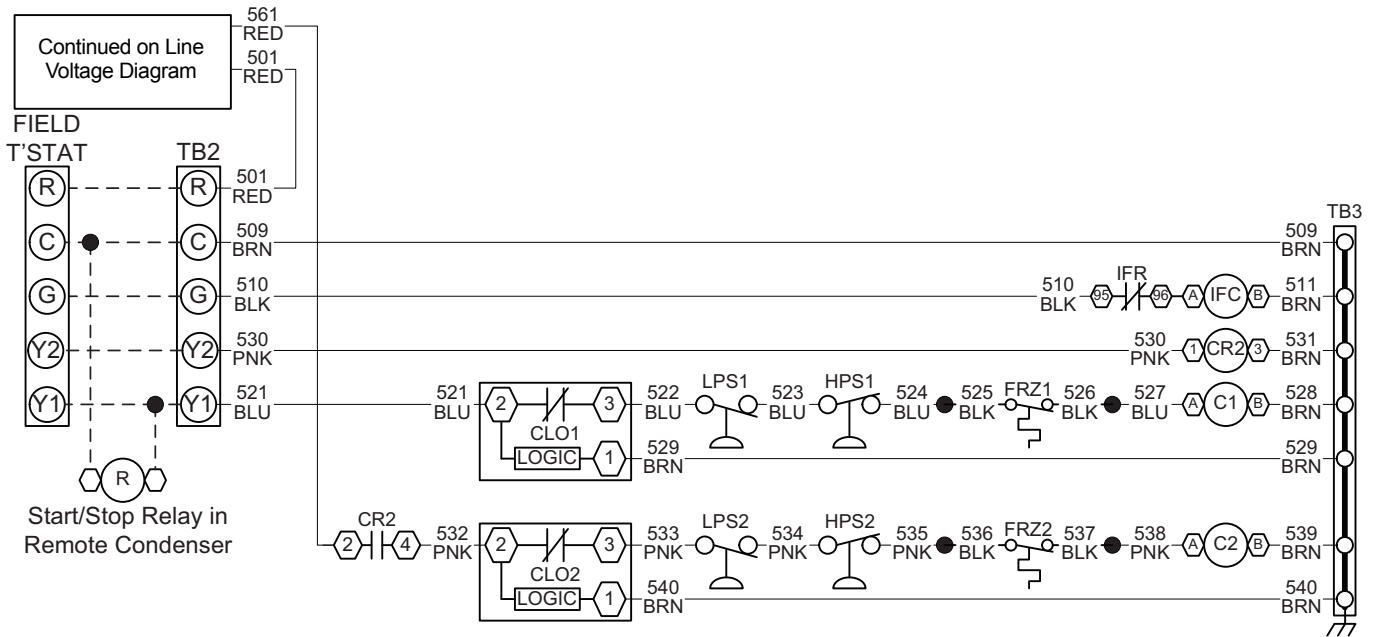

NOTE: See legend and notes on page 24.

Fig. 16 — Typical Wiring Schematic (50XCR12-24, 208/230-3-60 Units Shown) (cont)

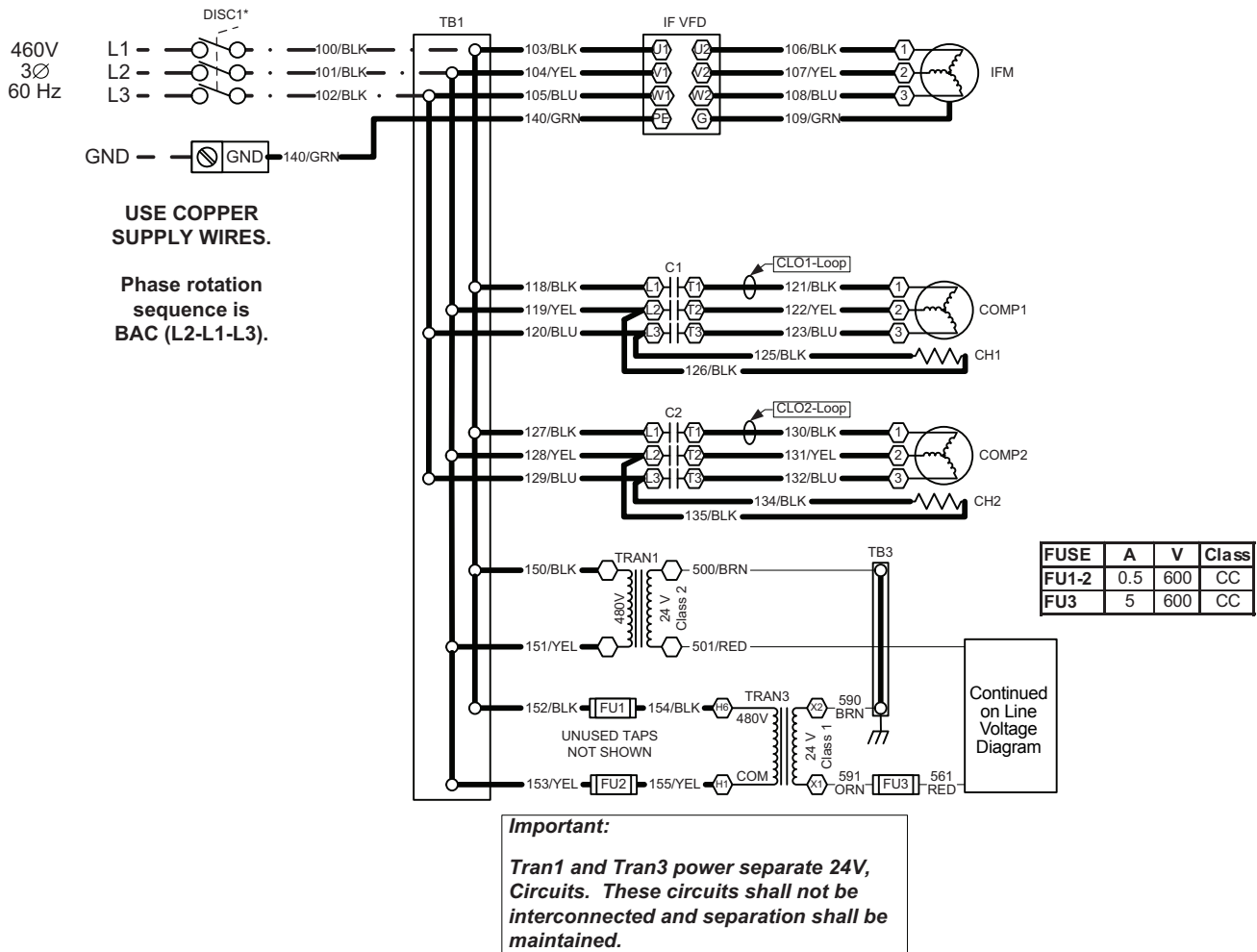

NOTE: See legend and notes on page 24.

Fig. 17 — Typical Wiring Schematic for 460-v Units (50XCR12-24 Units)

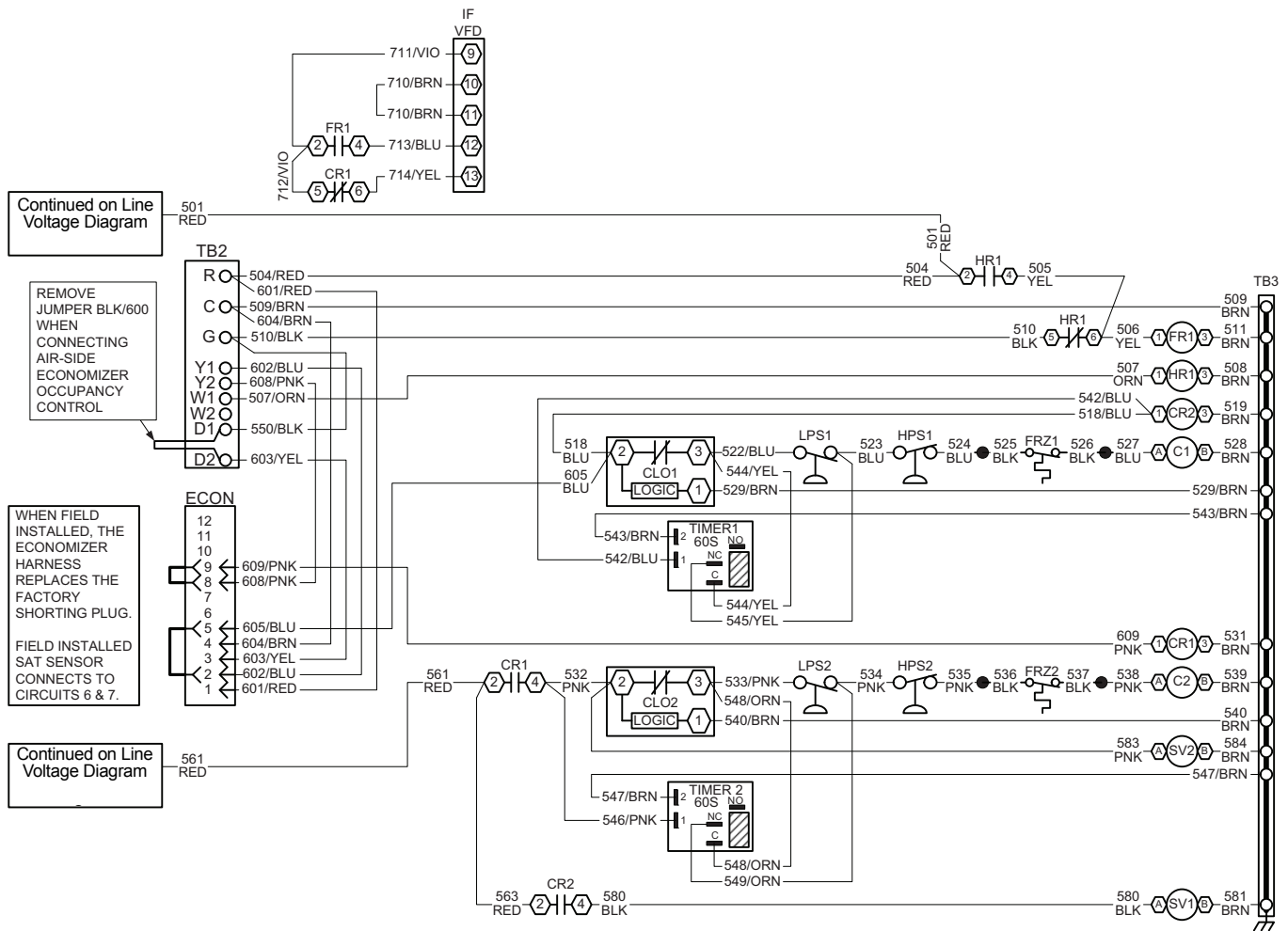

NOTE: See legend and notes on page 24.

Fig. 17 — Typical Wiring Schematic for 460-v Units (50XCR12-24 Units) (cont)

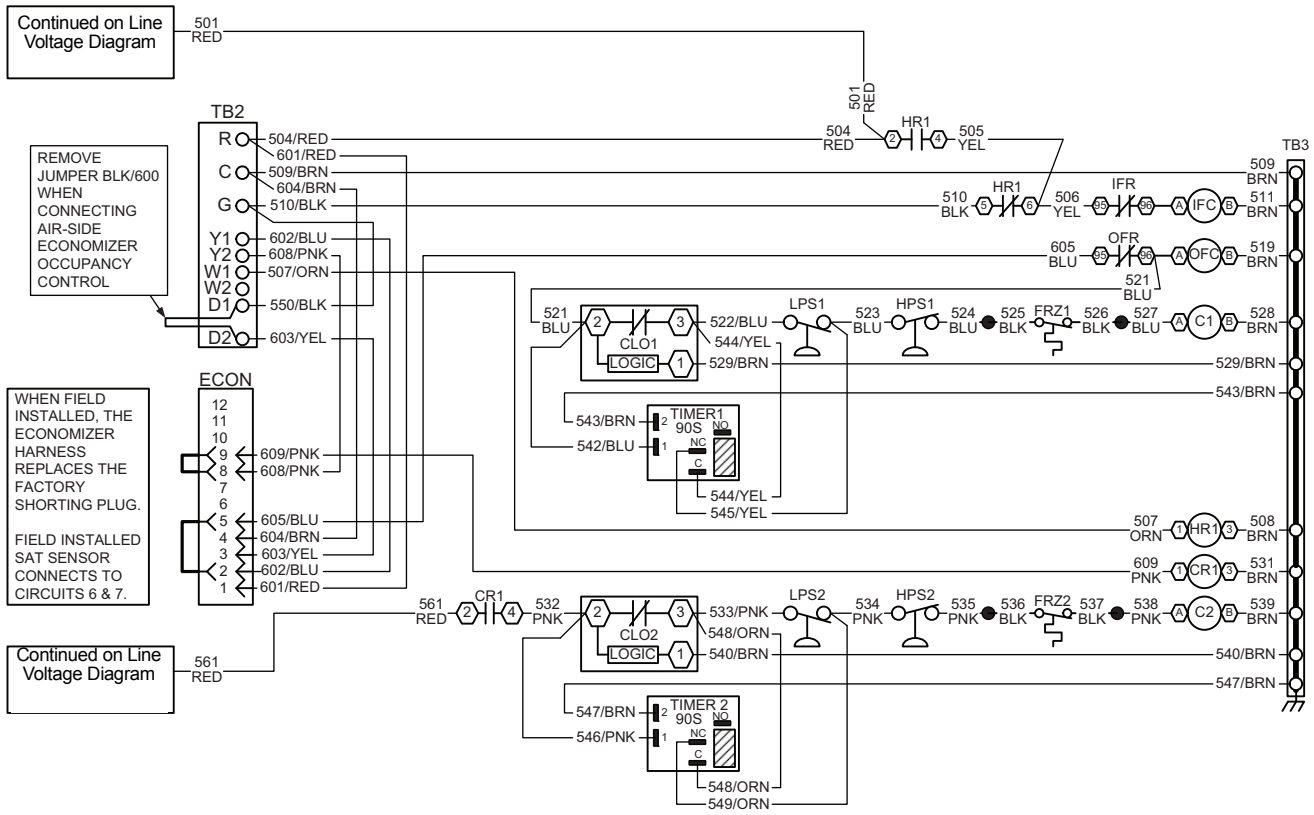

NOTE: See legend and notes on page 24.

Fig. 18 — Typical Wiring Schematic for Winter Start Kit (50XCR12-24 Units)

START-UP CHECKLIST

(Fill out this form on Start-Up and file in job folder)

NOTE: To avoid injury to personnel and damage to equipment or property when completing the procedures listed in this start-up checklist, use good judgment, follow safe practices, and adhere to the safety considerations/information as outlined in preceding sections of this Installation, Start-Up and Service document.

I. PRELIMINARY INFORMATION

50XCR UNIT: MODEL NO. _____ SERIAL NO. _____

FIELD-INSTALLED ACCESSORIES: _____

START-UP DATE: _____

II. PRE-START-UP:

VERIFY ALL SHIPPING MATERIALS HAVE BEEN REMOVED FROM THE UNIT

IS THERE ANY SHIPPING DAMAGE? _____ IF SO, WHERE _____

WILL THIS DAMAGE PREVENT UNIT START-UP? (Y/N) _____

CHECK POWER SUPPLY. DOES IT AGREE WITH UNIT? (Y/N) _____

HAS THE GROUND WIRE BEEN CONNECTED? (Y/N) _____

HAS THE CIRCUIT PROTECTION BEEN SIZED AND INSTALLED PROPERLY? (Y/N) _____

ARE THE POWER WIRES TO THE UNIT SIZED AND INSTALLED PROPERLY? (Y/N) _____

HAVE EVAPORATOR FAN AND MOTOR PULLEYS BEEN CHECKED FOR PROPER ALIGNMENT AND DO THE FAN BELTS HAVE PROPER TENSION? (Y/N) _____

HAS CORRECT FAN ROTATION OR EVAPORATOR BEEN CONFIRMED? (Y/N) _____

VERIFY CONDENSATE DRAIN HAS BEEN INSTALLED PER INSTRUCTIONS (Y/N) _____

HAS WATER BEEN PLACED IN DRAIN PAN TO CONFIRM PROPER DRAINAGE? (Y/N) _____

ARE PROPER AIR FILTERS IN PLACE AND ARE FILTERS CLEAN? (Y/N) _____

VERIFY UNIT IS INSTALLED WITHIN LEVELING TOLERANCES (Y/N) _____

CONTROLS

HAVE THERMOSTAT CONNECTIONS BEEN MADE AND CHECKED? (Y/N) _____

ARE ALL WIRING TERMINALS (including main power supply) TIGHT? (Y/N) _____

PIPING

CHECK WATER CONNECTIONS (Y/N) _____

CHECK THAT CIRCULATING PUMP IS ON AND RUNNING (Y/N) _____

LOCATE, REPAIR, AND REPORT ANY LEAKS

CHECK VOLTAGE IMBALANCE

LINE-TO-LINE VOLTS: AB _____ V AC _____ V BC _____ V

$(AB + AC + BC)/3 = \text{AVERAGE VOLTAGE} = \text{_____ V}$

MAXIMUM DEVIATION FROM AVERAGE VOLTAGE = _____ V
 VOLTAGE IMBALANCE = 100 X (MAX DEVIATION)/(AVERAGE VOLTAGE) = _____ %
 IF OVER 2% VOLTAGE IMBALANCE, DO NOT ATTEMPT TO START SYSTEM!
 CALL LOCAL POWER COMPANY FOR ASSISTANCE.

III. START-UP

CHECK INDOOR (EVAPORATOR) FAN SPEED AND RECORD. _____

AFTER AT LEAST 15 MINUTES RUNNING TIME, RECORD THE FOLLOWING MEASUREMENTS:

	CIRCUIT 1	CIRCUIT 2 (If Applicable)	CIRCUIT 3 (If Applicable)
SUCTION PRESSURE	_____	_____	_____
SUCTION LINE TEMP	_____	_____	_____
DISCHARGE PRESSURE	_____	_____	_____
DISCHARGE LINE TEMP	_____	_____	_____
ENTERING WATER TEMP	_____	_____	_____
LEAVING WATER TEMP	_____	_____	_____
EVAP ENTERING-AIR DB (dry bulb) TEMP	_____	_____	_____
EVAP ENTERING-AIR WB (wet bulb) TEMP	_____	_____	_____
EVAP LEAVING-AIR DB TEMP	_____	_____	_____
EVAP LEAVING-AIR WB TEMP	_____	_____	_____

COMPRESSOR AMPS:

L1	_____	_____	_____
L2	_____	_____	_____

SUPPLY FAN AMPS: _____

NOTES: _____

CUT ALONG DOTTED LINE

CUT ALONG DOTTED LINE