

**52M Performance™ Series  
Packaged Terminal Air Conditioner / Heat Pump  
7,000 – 15,000 Btuh**

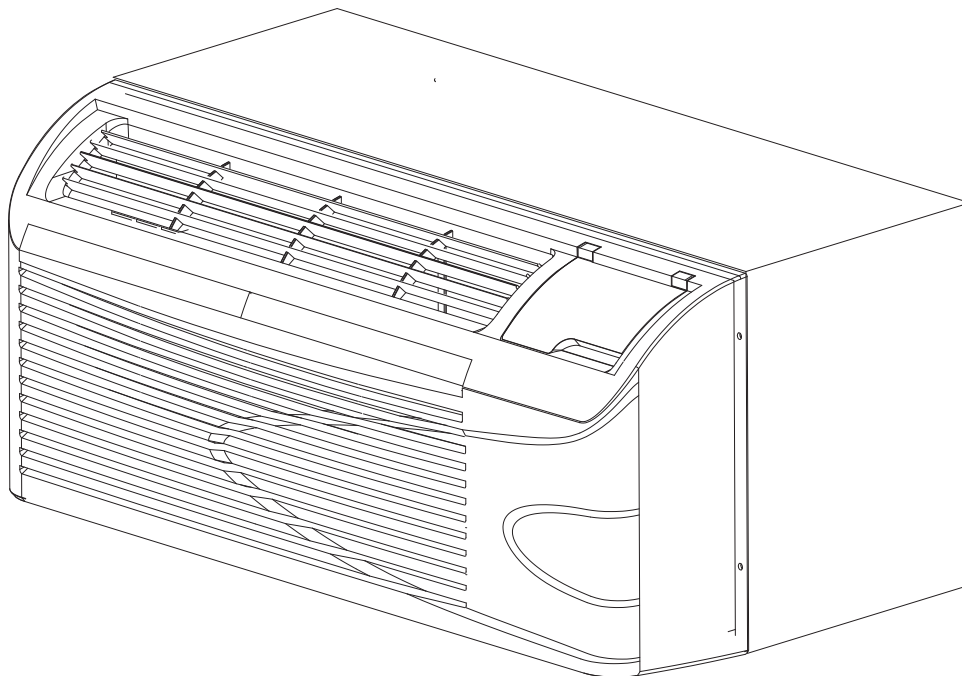

Turn to the Experts.®

# Installation and Operating Instructions



A07228

### NOTE TO EQUIPMENT OWNER:

Thank you for purchasing a Carrier PTAC. Please read this Owner's Information Manual carefully before installing and using this appliance. Keep this manual for future reference.

For your convenience, please record the model and serial numbers of your new equipment in the spaces provided. This information, along with the installation data and dealer contact information, will be helpful should your system require maintenance or service.

#### UNIT INFORMATION

Model # \_\_\_\_\_

Serial # \_\_\_\_\_

#### INSTALLATION INFORMATION

Date Installed \_\_\_\_\_

#### DEALERSHIP CONTACT INFORMATION

Company Name: \_\_\_\_\_

Address: \_\_\_\_\_

Phone Number: \_\_\_\_\_

Technician Name: \_\_\_\_\_

\_\_\_\_\_

# UNIT INSPECTION

Examine unit for damage incurred during shipment. File a claim immediately with the transit company if damage is found.

## TABLE OF CONTENTS

	PAGE
SAFETY CONSIDERATIONS .....	3
GENERAL INFORMATION .....	3
UNIT FEATURES .....	4 - 5
ELECTRICAL DATA .....	6
INSTALLATION	
Chassis Installation .....	7
Retrofit Sleeve Preparation .....	8
Installation of Carrier Wall Sleeve Using Non-Carrier Grille .....	8
Install Unit Into Wall Sleeve .....	9
HOW TO CONNECT .....	10
SYSTEM CONFIGURATION	
Ventilation Control .....	11
Adjusting Air Direction .....	11
Dipswitches .....	12
Keypad Configuration .....	13
AUXILIARY CONTROLS	
Wall Thermostat Terminal .....	14 - 15
Energy Management Input .....	15
Intelligent Self-Checking Control .....	15
OPERATION .....	16
CARE AND CLEANING .....	17
PREVENTATIVE MAINTENANCE .....	18
TROUBLESHOOTING .....	19
WARRANTY .....	23 - 24

**For Service/Technical Assistance**  
**1•800•894•6449 (in USA and Canada)**

**NOTE: Warranty coverage documented on back page of owners manual**

# READ ALL INSTRUCTIONS BEFORE INSTALLATION OR USE

## SAFETY CONSIDERATIONS

Recognize safety information. This is the safety-alert symbol . When you see this symbol on the unit and in instructions or manuals, be alert to the potential for personal injury.

Understand these signal words: DANGER, WARNING, and CAUTION. These words are used with the safety-alert symbol. DANGER identifies the most serious hazards which **will** result in severe personal injury or death. WARNING signifies hazards which **could** result in personal injury or death. CAUTION is used to identify unsafe practices which **may** result in minor personal injury or product and property damage. NOTE is used to highlight suggestions which **will** result in enhanced installation, reliability, or operation.

 **WARNING**

**PERSONAL INJURY AND/OR PROPERTY DAMAGE HAZARD**

Failure to follow this warning could result in personal injury, death and/or property damage.

For your safety, the information in this manual must be followed to minimize the risk of fire or explosion, electric shock, or to prevent property damage, personal injury, or loss of life.

- This unit must be properly installed in accordance with the Installation Instructions before it is used.
- Immediately repair or replace all electric service cords that have become frayed or otherwise damaged.
- Unplug or disconnect the unit at the fuse box or circuit breaker before making any repairs.

**NOTE:** We strongly recommend that any servicing be performed by a qualified individual.

## GENERAL

Thank you for choosing Carrier's best PTAC ever! You can feel confident in your selection because the same pride in craftsmanship and engineering knowledge that goes into Carrier equipment at the Astrodome in Texas, the Sistine Chapel in Rome, the US Capitol Hall of Congress, and thousands of other installations worldwide has gone into the construction of this unit.

Carrier package terminal air conditioners and heat pumps provide a high standard of quality in performance, workmanship, durability and appearance as they heat and cool the occupied air space year round.

This manual provides information for ease of installation, operation and maintenance.

All models are designed for through-the-wall installation. Separate installation instructions are included with all accessory components.

## BEFORE YOU BEGIN

Read these instructions completely and carefully.

**IMPORTANT:** Save these instructions for local inspector's use.

**IMPORTANT:** Observe all governing codes and ordinances.

## NOTE TO INSTALLER

Be sure to leave these instructions with the owner.

## NOTE TO OWNER

Keep these instructions for future reference. Be sure to write down the model and serial number of unit on space provided on front page. The model and serial number can be located on the serial number plate attached to unit. These numbers are required for service. (See Fig. 1.)

Save the wall thermostat control panel label to be placed on control panel in case a wall thermostat is used or is added in the future. (See Fig. 24)

Location of Model and Serial Number of Unit





 <p style="font-size: 0.7em;">MADE IN CHINA BE AWARE OF THE CARRIER UNIT NO.</p>	<b>MODEL</b>	<b>COOLING</b>				<b>HEATING</b>			
	<b>SERIAL</b>	BTU/HR	AMPS	WATTS	SEER	BTU/HR	AMPS	WATTS	COP
<b>DATE OF MFG</b>	<b>VOLTS</b>	COOLING		HEATING		CANADIAN INSTALLATION		USE TIME DELAY FUSE OR CIRCUIT BREAKER	
<b>VOLTS RANGE</b>	<b>PH</b>	MAX FUSE	MAX BREAKER	MAX FUSE	MAX BREAKER	MAX FUSE	MAX BREAKER	MAX FUSE	MAX BREAKER
<b>PH</b>	<b>MIN OCT CAPACITY</b>	COOLING	HEATING	COOLING	HEATING	COOLING	HEATING	COOLING	HEATING
<b>R-22 OZ</b>	<b>PH</b>	COOLING	HEATING	COOLING	HEATING	COOLING	HEATING	COOLING	HEATING
<b>SECTION P310 3RD HIGH SIDE, 1ST LOW SIDE</b>	<b>NOTOR</b>	COOLING	HEATING	COOLING	HEATING	COOLING	HEATING	COOLING	HEATING
<b>PART NO. REV.</b>		COOLING	HEATING	COOLING	HEATING	COOLING	HEATING	COOLING	HEATING

**CORD CONNECTED UNIT**

POWER SUPPLY	CIRCUIT	MAX. HEATING		COOLING	
		AMPS	WATTS	AMPS	WATTS

USE TIME DELAY FUSE OR CIRCUIT BREAKER

INSTALLER: TO DETERMINE THE ELECTRICAL HEAT RATINGS OF THIS UNIT MATCH THE POWER SUPPLY KIT MODEL NO. WITH THE TABLE

FOR SERVICE/TECHNICAL ASSISTANCE IN THE U.S. & CANADA TELEPHONE

1-800-894-6449

IN MEXICO TELEPHONE

1-800-830-8600

Fig. 1 – Sample Data Information Plate

A07229

## UNIT FEATURES

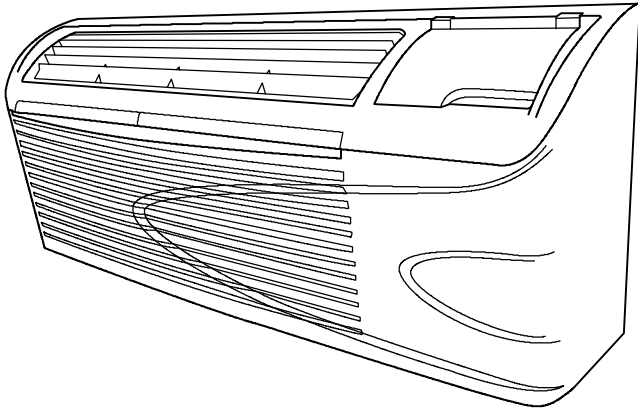

Fig. 2 – Model 52M

This Premium unit has many exciting features which are different than those found on standard PTAC models. The owner must be familiar with these features in order to fully understand the operation and capability of the unit.

- **Intelligence** – Your Premium unit has an on board computer that utilizes real time diagnostics to prolong the life of your unit. There is an LED indicator on the control board, behind the front panel, that will flash an error code if the unit has detected some kind of fault condition. In many cases, the unit will automatically clear the fault condition and continue operating with no interruption. In some cases, the condition cannot be cleared and the unit will require service. In those cases, an “Fx” failure mode will be displayed on the digital display. For a detailed list of all error codes and “Fx” conditions, see Table 6 – *Status LED Indicator Definitions* for further details.

- **Memory** – Your Premium unit also has memory. If power is lost, all of the control settings (setpoint, mode, fan speed, on/off and configuration) are remembered. So when power is restored, the unit will start back up in the mode (and configuration) it was in, when power was lost.

- **Premium Sound** – Your Premium unit is also Carrier’s quietest PTAC ever. Not only does it have 2 fan motors and a tangential blower wheel for optimum sound, the indoor fan will always run a minimum of 10 seconds before the compressor, to help reduce any compressor starting noise.

- **Random Compressor restart** – To help prevent power surges after a power outage (from many of your PTACs starting at the same time), the compressor is equipped with a 2:45 to 3:15 random restart delay feature. Whenever the unit is plugged in, or power has been restarted, a random compressor restart will occur.

- **Compressor Protection** – To prevent short cycling of the compressor and maximize it’s life, there is a random start-up delay of 3 minutes on the compressor and a minimum compressor run time of 3 minutes.

- **Automatic room freeze protection** – automatically will keep the temperature in the room from getting too cold, where water pipes might freeze. If the unit is configured for the freeze protection feature to be active (which is the default condition), then whenever power is supplied to the unit, if the unit senses temperature below 40°F (4.4°C), the fan motor and electric heater are turned on and will warm the room to 50°F (10°C). If Freeze protection is not required, change the configuration switch to turn the feature off (see section on unit configuration).

- **Automatic defrost protection (for heat pump models only)** – When the outdoor temperature gets too cold (approx. 40°F / 4.4°C) and the unit can no longer effectively heat with the compressor, the unit will automatically switch to electric heating. The unit will then heat with electric heat until the outside temperature rises enough (approx. 40°F / 4.4°C), so the compressor can be used again.

- **Automatic Quick Warm-up (for heat pump models only)** – If the room temperature falls to 5°F (2.8°C) below the set point temperature, the reverse cycle heat is shut off and the electric strip heat is turned on for one cycle, until heating is satisfied.

- **LED Indicator’s and Buttons** – The touch pad has buttons for MODE, FANSPEED, ON/OFF, SETPOINT UP and SETPOINT DOWN. It also has LEDs that correspond to the mode, fan speed and setpoint operation, to indicate the unit’s status. The LEDs below the mode button, FAN, COOL, and HEAT, indicate what operating mode is active. The LEDs below the Fan button, Low, Med and Hi, indicate the fan speed that is selected. The LED located in the lower right corner is the unit On/Off status LED. If the unit is in ON mode, the LED will be green. If the unit is OFF, the LED will be red.

- **Configure Fan to Optimize Selected Application** – Unit can be optimized to selected application by configuring the fan to run in continuous mode or cycle on and off with the compressor and electric heater (can be different for both heating and cooling modes). In cycle mode, fan will continue to run after compressor or electric heater stops in order blow off any residual heat or cool left on coil.

## UNIT FEATURES CONTINUED

• **Unit Configuration** – There are many different configuration possibilities, through both dipswitches and the digital keypad, that allow you to configure the unit for your exact application. See section on unit configuration for more details. Following are the configuration selections that have not previously been mentioned:

- **°F or °C** – The unit can display in either °F or °C
- **Indoor Temperature Sensor Biasing** – Optimize the room temperature sensor reading to your exact application (one for cooling and another for heating)..
- **Emergency Heat (for Heat Pump Only)** – Disable the compressor during heating mode operation (heat only with Electric Heat).
- **Display Setpoint OR Room Temperature** – The unit can be configured to display the room temperature OR setpoint only, during heating and cooling modes. See section on unit configuration for more details.

• **Limit the Setpoint Range** – The unit can be configured to limit the controlling setpoint range. The display will always show the complete setpoint range, but the controlling setpoint will be limited to the configured minimum and maximum setpoint selected. See section on unit configuration for more details.

• **Energy Management** – Sometimes known as *Front Desk Control*, an input is provided so that the unit can be manually disabled from a different location. If the unit detects 24vac on this input, it will automatically turn itself off. If no voltage is detected on the input, the unit will run normally.

• **Wall Thermostat Control** – A wired wall thermostat can be connected to the unit. If it is, the unit must be configured to disable the keypad. See section on wired inputs and unit configuration for more details.

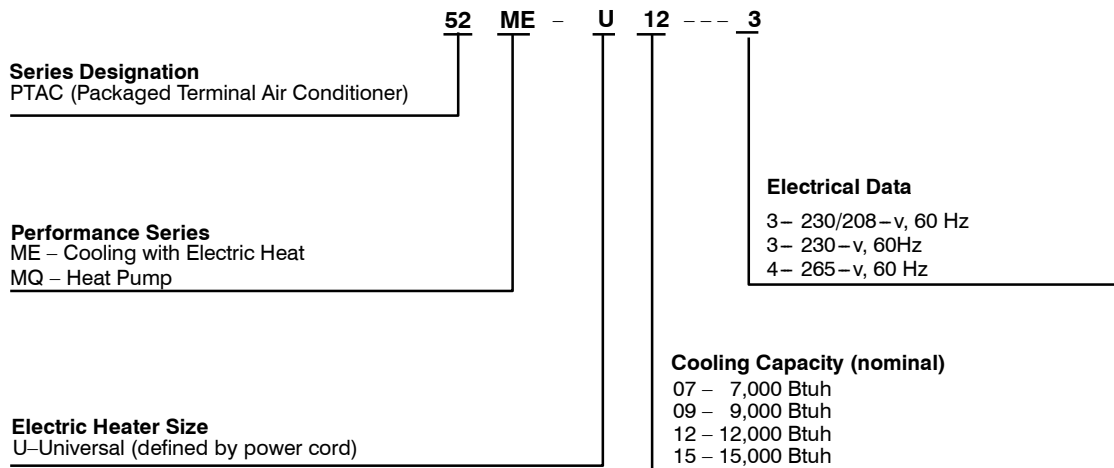

Fig. 3 – Catalog Number Nomenclature

A07053

## ELECTRICAL DATA

### ⚠ WARNING

#### ELECTRICAL SHOCK HAZARD

Failure to follow this warning could result in personal injury or death and/or property damage

DO NOT alter cord or plug or use an extension cord.

### POWER CONNECTION OPTIONS

Appropriate power cord accessory kit is determined by the voltage, and amperage of the branch circuit. **The unit does not come with a power cord (or hard wire kit).** An accessory power cord kit must be ordered to connect the unit to the outlet. If the unit is to be hard wired, an accessory hard wire kit must be ordered.

### ⚠ CAUTION

#### EQUIPMENT DAMAGE HAZARD

Failure to follow this caution may result in equipment damage or improper operation.

Using a 30 amp cord on -U07 and -U09 models could result in damage the unit. For these models, use 15 or 20 amp power cords only.

**IMPORTANT: For 265V units, if power cord accessory option is selected, the cord is only 18” long and must plug into the accessory electrical 265V subbase.**

Be sure that your outlet matches the appropriate blade configuration of the plug and that it is within reach of the service cord.

All wiring, including installation of the receptacle, must be in accordance with the NEC and local codes, ordinances and regulations. National codes require the use of an arc fault or leakage current detection device on all 208/230V power cords. Be sure to select the correct cord for your installation.

### ALL UNITS

#### Wire Size

Use recommended wire size given in Table 1 and install a single branch circuit. All wiring must comply with local and national codes. **All units are**

**designed to operate off ONE single branch circuits only.**

**NOTE:** Use copper conductors only.

**Table 1—SUGGESTED BRANCH CIRCUIT WIRE SIZES\***

NAMEPLATE AMPS	AWG WIRE SIZE†
7.0 to 12	14
12.1 to 16	12
16.1 to 24	10

#### LEGEND

AWG – American Wire Gauge

\* Single circuit from main box.

† Based on copper wire at 60°C temperature rating.

### Grounding

For safety and protection, the unit is grounded through the service cord plug or through separate ground wire provided on hard wired units. Be sure that the branch circuit or general purpose outlet is grounded.

### VOLTAGE SUPPLY

Check voltage supply at outlet. For satisfactory results, the voltage range must always be within the ranges found on the data information plate.

### Cord-connected Units

The 250-v field supplied outlet must match the plug for the standard 208/230-v units and be within reach of the service cord. The standard cord-connected 265-v units require an accessory electrical subbase for operation. Refer to Table 2 for proper receptacle and fuse type.







### Power Cord Protection

The power cord for 208/230v units provide power cord fire protection. Unit power automatically disconnects when unsafe conditions are detected. Power to the unit can be restored by pressing the reset button on plug head.

Upon completion of unit installation for 208/230V models, an operational check should be performed using the TEST/RESET buttons on the plug head.

**NOTE:** The 265v models do not incorporate this feature as they require use of the electrical subbase accessory.

**Table 2—RECEPTACLES AND FUSE TYPES - 250, 265 VOLTS**

RECEPTACLE						
AMPS	15	20	30	15	20	30
RATED VOLTS	250	250	250	265	265	265
TIME-DELAY TYPE FUSE (or HACR Circuit Breaker)	15	20*	30	15	20	30

#### LEGEND

HACR – Heating, Air Conditioning, Refrigeration

\* May be used for 15-amp applications if fused for 15 amps.

# INSTALLATION

Proper installation is the responsibility of the installer.

Product failure due to improper installation is not covered under the Warranty.

## CHASSIS INSTALLATION

Units are shipped without a sleeve. In applications where unit is a replacement, it is recommended that a Carrier sleeve be used.

These units can retrofit General Electric, Amana, Trane, and Friedrich sleeves/grilles (be sure outdoor grille is installed on the sleeve). See Table 3 for details. Carrier Corporation must approve any other retrofit application.

For competitive retrofit applications, be sure that the foam seals (factory-installed on the tube sheets) provide a good seal between the grille and outdoor coil tube sheets. These foam seals provide a barrier to separate outdoor coil leaving air from mixing with the outdoor incoming air (known as air recirculation).

**⚠ CAUTION**

**UNIT DAMAGE AND/OR OPERATION HAZARD**

Failure to follow this caution may result in equipment damage or improper operation.

For retrofit applications, foam seals on outdoor coil tube sheets must make a seal between the coil and the grille or loss of performance and premature damage to the major components can result.

**Table 3—Retrofit Wall Sleeves**

Manufacturer	Wall Sleeve Part Number
<b>General Electric</b>	Metal Sleeve RAB71
	Plastic Sleeve RAB77
<b>Amana</b>	Metal Sleeve WS900D
<b>Trane</b>	Metal Sleeve SLV149
<b>Friedrich</b>	T-Series Metal 11-1/2" (292.1 mm) Deep Wall Sleeve*
	Standard Depth Wall Sleeve 16 X 42 X 13 <sup>3/4</sup> -in. (406.4 X 1067 X 349.3 mm) PXWS

\* FR-SLEEVE-EXT accessory is required for retrofit into Friedrich (T-Series) wall sleeves.

**Minimum wall sleeve opening must be greater than 14.75 X 40.00 in. (374.7 x 1016 mm)**

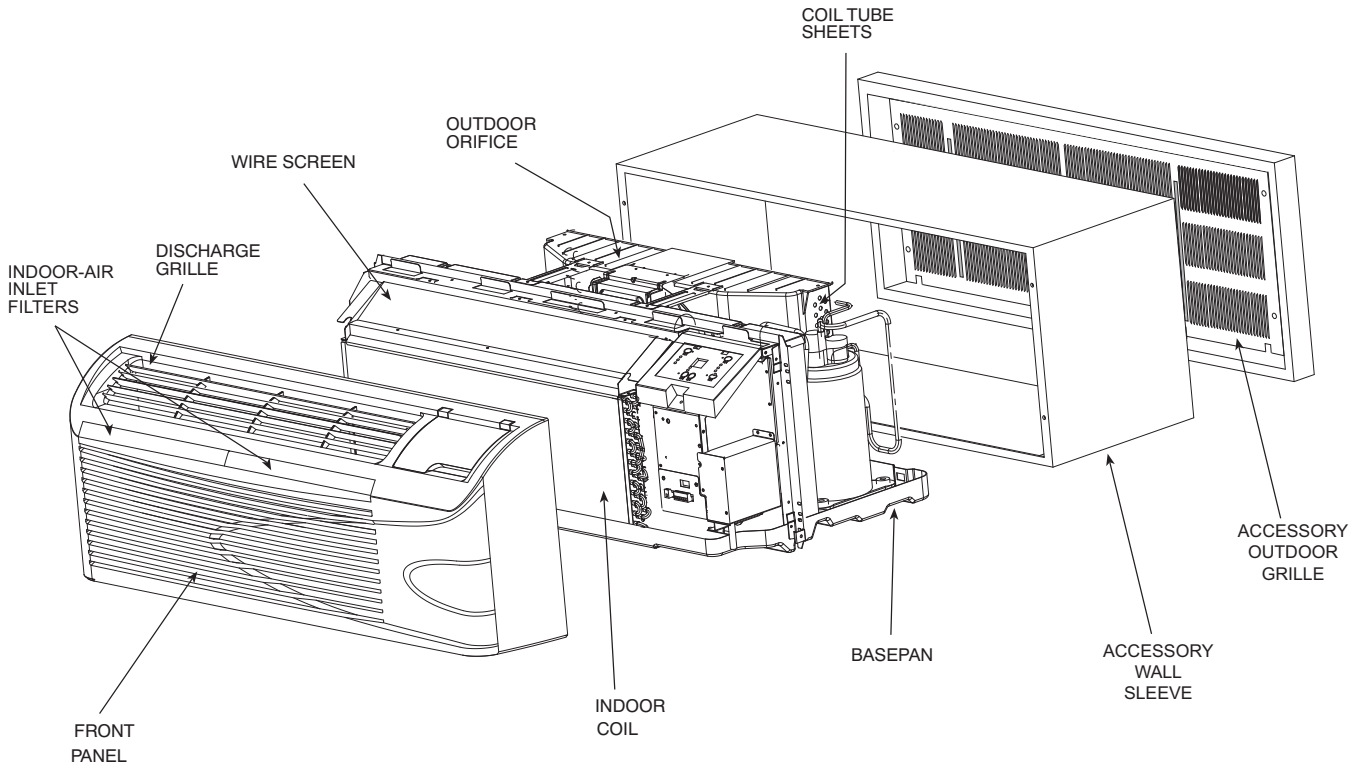

**Fig. 4 – Unit Components**

A06752

## RETROFIT SLEEVE PREPARATION

**IMPORTANT:** Inspect wall sleeve thoroughly prior to installation. Manufacturer does not assume responsibility for costs or damages due to defects in sleeve or for improper installation.



### WARNING

#### ELECTRICAL SHOCK HAZARD

Failure to follow this warning could result in personal injury or death.

Disconnect all power to unit to avoid possible electrical shock during installation.

### GE Sleeves Only

**GE Metal Wall Sleeve** - Remove metal clip on mounting rail located on left, inside bottom, of metal sleeve and discard. See Fig. 5

**GE Plastic Sleeve** - Remove bottom seal from plastic sleeve. See Fig. 6.

### INSTALLATION OF A CARRIER WALL SLEEVE USING A NON-CARRIER GRILLE

This application has become more common due to pre-manufactured windows with built-in grilles or renovations where a Carrier sleeve is used with an existing non-Carrier grille.

Use of a Carrier wall sleeve with a non-Carrier grille requires installation of an Accessory Baffle Kit (see Fig. 8), which ensures a good seal between the unit and exterior grille to prevent air recirculation. Air recirculation is a large contributor to performance loss and premature damage to major components.

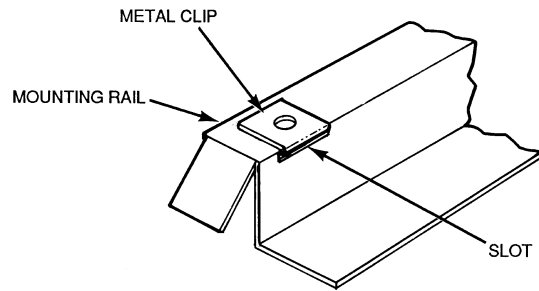

Fig. 5 – Remove Metal Clip on GE Metal Sleeve

A07055

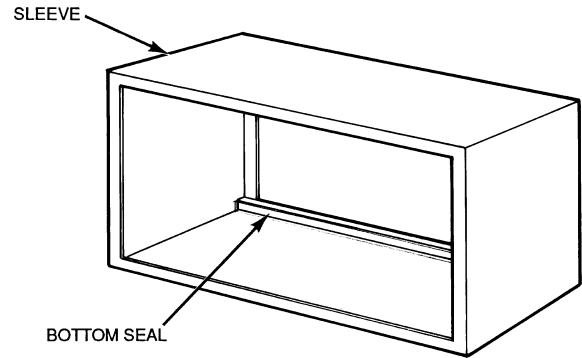

Fig. 6 – Remove Bottom Seal From GE Plastic Sleeve

A07056

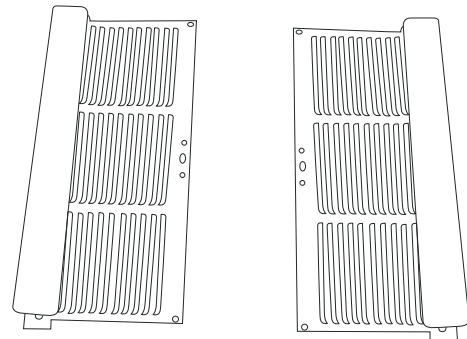

Fig. 7 – Accessory Baffle Kit

A07275



# INSTALL UNIT INTO WALL SLEEVE

1. Carefully remove shipping tape from the front panel and vent door. See Fig. 8.
2. Remove shipping screw from the vent door, if present. See Fig. 9.
3. Remove front panel. See Fig. 10.
4. Lift unit level and slide unit into wall sleeve until foam seal rests firmly against front of wall sleeve.
5. Secure with four screws (supplied) through the unit flange holes. See Fig. 11.
6. Reinstall front panel. See Fig. 12.

**⚠ WARNING**

**PERSONAL INJURY HAZARD**

Failure to follow this warning could result in personal injury or death.  
 Chassis weighs up to 150 pounds (68.0 kg). Seek help when lifting unit.  
 Lift unit by holding unit basepan.

**⚠ CAUTION**

**UNIT DAMAGE HAZARD**

Failure to follow this caution may result in equipment damage or improper operation.

Failure to remove shipping tape and screw will prevent fresh air vent door from opening and may result in damage to vent door cable

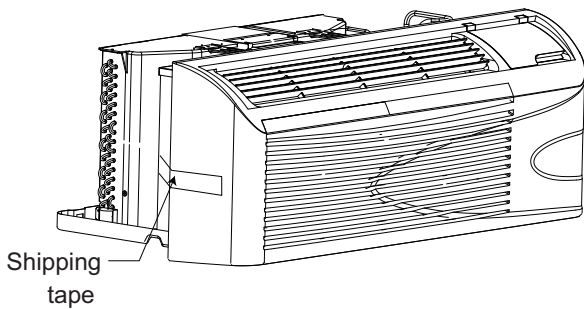

**Fig. 8 – Shipping Tape Location**

A07066

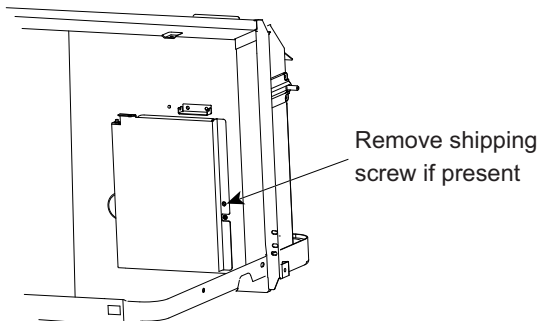

**Fig. 9 – Shipping Screw Location**

A07067

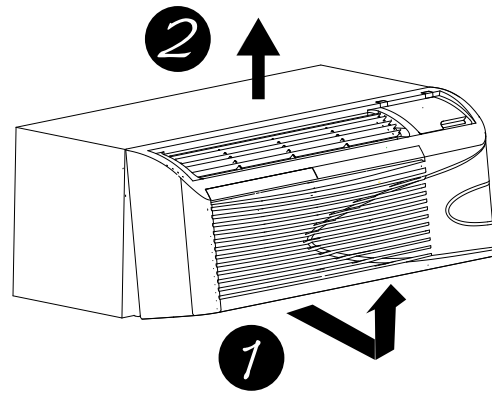

Pull out at the bottom to release it from the tabs (1). Then lift up (2).

**Fig. 10 – Removing Front Panel**

A07064

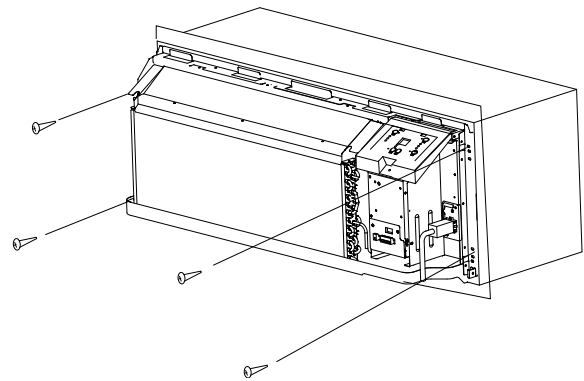

**Fig. 11 – Securing Unit**

A07057

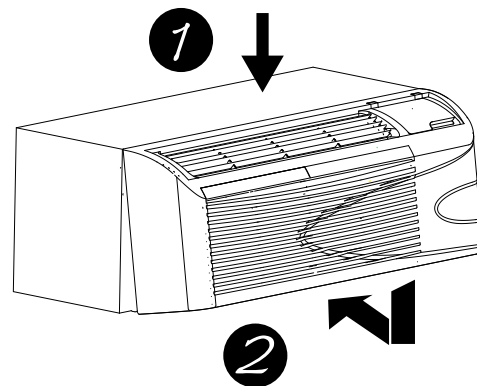

Place tabs over top rail (1). Push Inward at bottom until panel snaps into place (2).

**Fig. 12 – Replacing Front Panel**

A07065

# HOW TO CONNECT

**IMPORTANT:** Please read following electrical safety data carefully.

⚠ **WARNING**

**ELECTRICAL SHOCK AND/OR UNIT OPERATION AND DAMAGE HAZARD**

Failure to follow this warning could result in personal injury or death and/or unit operation and damage.

- Follow the National Electrical Code (NEC) or local codes and ordinances.
- For personal safety, this unit **MUST BE** properly grounded.
- Protective devices (fuses or circuit breakers) acceptable for unit installations are specified on the nameplate of each unit.
- **Do not** use an extension cord with this unit.
- Aluminum building wiring may present special problems - consult a qualified electrician.
- **When unit is in STOP position, there is still voltage to electrical controls.**
- Disconnect power to unit before servicing by:
  1. Removing power cord (if it has one) from wall receptacle.
  2. Removing branch circuit fuses or turning circuit breakers off at panel.

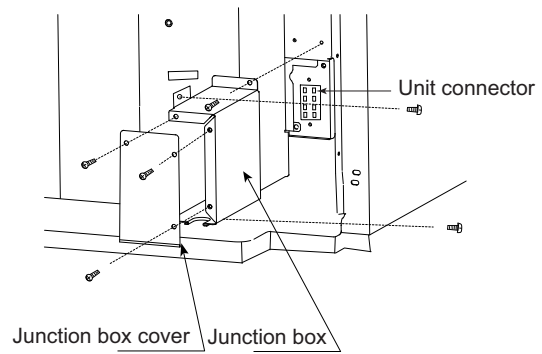

**Fig. 13 – Junction Box Location**

A07058

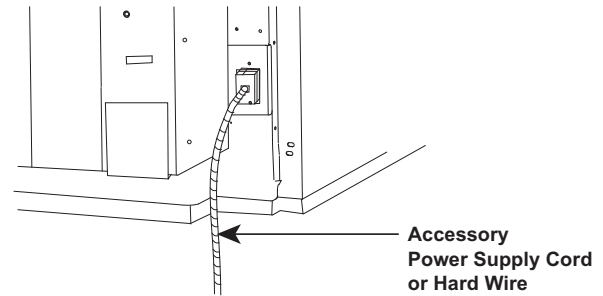

**Fig. 14 – Power Connection**

A07059

1. Remove front panel. See Fig. 11.
2. Remove junction box.
  - Remove junction box cover by removing three screws from front. Remove junction box by taking out top, rear and side screws. See Fig. 14.
3. Connect accessory power supply cord or hard wire connector to unit connector. See Fig. 15.
  - Units must be installed using the appropriate power supply kit. See Table 4 - POWER CONNECTION CHART. These connections must be followed.
4. Reinstall junction box and cover.
  - Use wire clamp to attach power cord to basepan. Secure with screws (included) See Fig. 16.
  - Replace junction box and cover with screws removed from Step 2. Tighten securely.
5. Replace front panel. See Fig. 13.
6. Connect power to unit.

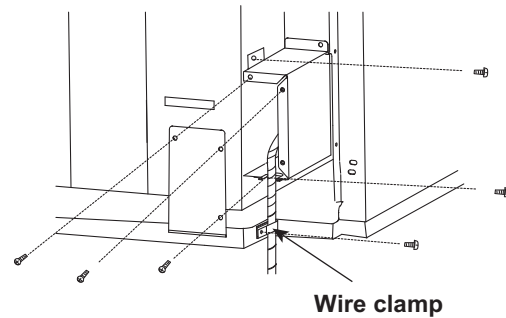

**Fig. 15 – Wire Clamp**

A07060

**Table 4—POWER CONNECTION CHART**

UNIT MODEL	CODE OF POWER SUPPLY KIT		
	30A	20A	15A
	<b>208/230 VOLT</b>		
52ME-U07---3	N/A*	PWRCORD- 230V-20A	PWRCORD- 230V-15A
52MQ-U07---3			
52ME-U09---3			
52MQ-U09---3			
52ME-U12---3	PWRCORD- 230V-30A		
52MQ-U12---3			
52ME-U15---3			
52MQ-U15---3			
	<b>265 VOLT</b>		
52ME-U07---4	N/A*	PWRCORD- 265V-20A	PWRCORD- 265V-15A
52MQ-U07---4			
52ME-U09---4			
52MQ-U09---4			
52ME-U12---4	PWRCORD- 265V-30A		
52MQ-U12---4			
52ME-U15---4			
52MQ-U15---4			

\* Using 30A on these units could result in damage to your unit.

# SYSTEM CONFIGURATION

## VENTILATION CONTROL

The ventilation control lever is located at left side of unit, behind front panel.

**NOTE:** The vent door shipping hardware must be removed before using vent control lever. See Installation Instructions.

When set at **CLOSE**, only the air inside the room is circulated and filtered.

When set at **OPEN**, some outdoor air will be drawn into room. This will reduce heating or cooling efficiency.

**Energy Tip:** Keep the vent control at **CLOSE**. Room air will be filtered and circulated.

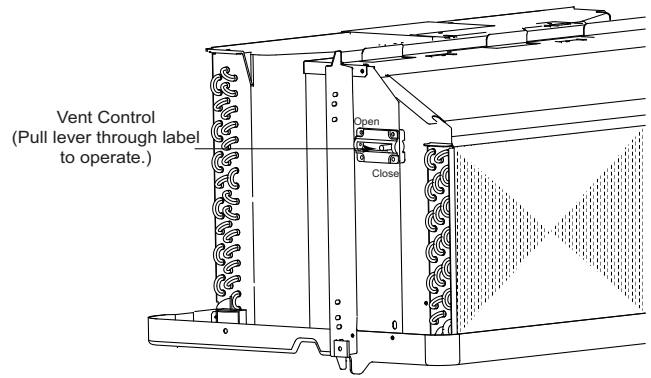

Fig. 16 – Ventilation Control Location

A07068

## ADJUSTING AIR DIRECTION

### To adjust air direction:

1. Remove front panel. See Fig. 11.
2. Remove louver screws that hold louver insert in place (from back side of front panel). See Fig. 18.
3. Turn louver insert and rotate 180°. See Fig. 19.
4. Replace louver insert.
5. Replace screws and front panel.

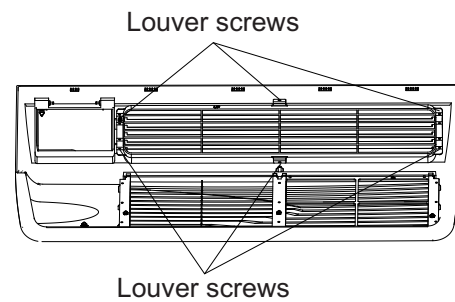

Fig. 17 – Backside of Front Panel

A07069

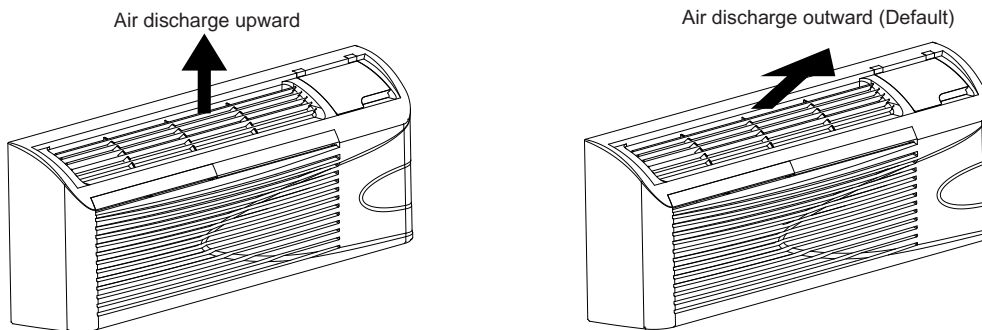

Fig. 18 – Adjusting Louvers

A07070

## DIP SWITCHES

Auxiliary dip switch controls are located behind front panel, through an opening below the control panel. To access, remove front panel. See Fig. 11.

Dip switches are accessible without opening the control box. Unit must be powered **OFF** to effectively change their status.

Factory settings for dip switches will be in the **DOWN** position. See Table 5 - *Dip Switch Functions* for functions of each dip switch position.

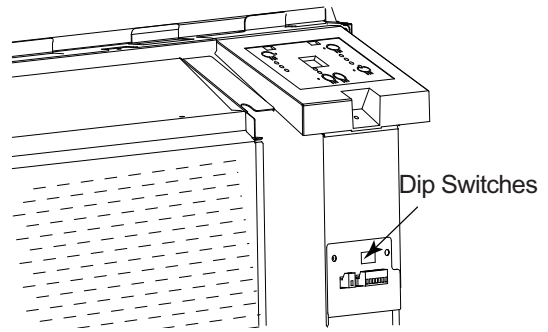

Fig. 19 – Dipswitch Location on Unit

A07071

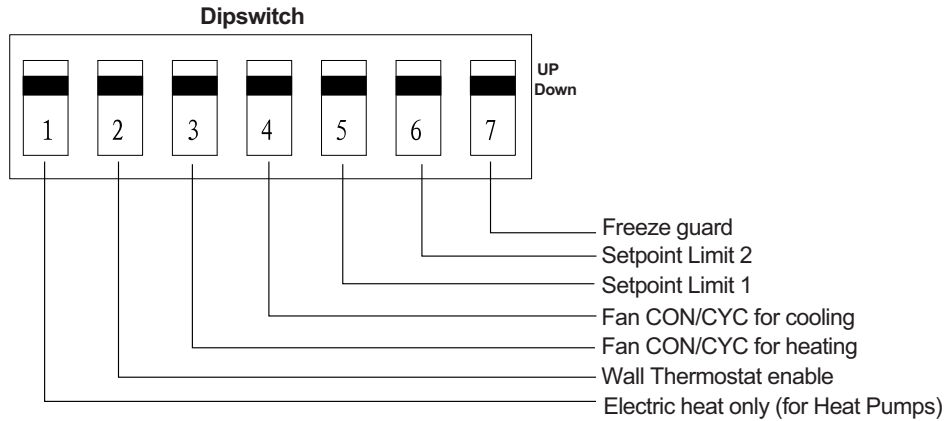

Fig. 20 – Dip Switches

A07072

Table 5—DIP SWITCH FUNCTIONS

No.	UP		DOWN		REMARKS	DEFAULT
1	Electric Heat Only		Heat Pump		For Heat Pump unit only.	DOWN
2	Wall Thermostat Enable		Control Panel Enable			DOWN
3	Fan Continuous Run for Heating		Fan Cycle for Heat			DOWN
4	Fan Cycle for Cool		Fan Continuous Run for Cooling			DOWN
5*6	UP*UP 68–75 °F 20–24 °C	UP*DOWN 63–80 °F 18–28 °C	DOWN*UP 65–78 °F 19–26 °C	DOWN*DOWN 61–86 °F 16–30 °C (full range)	Two configurations (5*6) combine to select set point range. When set point limit set, display always shows full range.	DOWN*DOWN 61–86 °F 16–30 °C
7	Freeze Guard Disable		Freeze Guard Enable			DOWN

### Electric Heating Only / Emergency Heat (For Heat Pump Units Only)

This setting is typically used for Emergency Heating.

### Wall Thermostat Enable

A wired wall thermostat can be connected to the unit. If it is, this dipswitch must be moved to the Wall Thermostat Enable Position, before the wall thermostat will begin control.

### Heat and Cool Fan CON/CYC Dip-switches

Allows the fan to operate in continuous or cycle modes while the unit is in heating or cooling mode (continuous or cycle):

### CON (Continuous)

Allows fan to run continuously, circulating air even when the temperature setting has been satisfied. This switch helps to maintain the room temperature closer to the thermostat setting.

### CYC (Cycle)

This setting allows the fan to cycle on and off with the compressor or electric heater. The fan stops a short time after the temperature setting is satisfied.

### Setpoint Temperature Limits

Provides a restricted range of temperature control.

### Room Freeze Protection

If unit senses a room temperature below 40°F (4.4°C), the fan motor and electric strip heat will turn on and warm the room to 50°F (10°C). The fan stops a short time after the temperature is satisfied.

## **KEYPAD CONFIGURATION**

### **Keypad Configuration**

Allows further configuration of system to desired application. Changes do not take affect until power is cycled on the unit.

### **To enter Keypad configuration**

Cycle power to unit. Press and hold the Fan Speed Button and the COOLER button for 5 continuous seconds, within 30 seconds of the unit being powered up. If the unit has had power for more than 30 continuous seconds, keypad configuration cannot be entered. When keypad configuration mode is first entered, it will default to Fahrenheit/ Celsius Display Mode.

### **To scroll through the Keypad Configuration**

#### **Options**

Press and release the Fan Speed button. The stored value will be displayed.

### **To modify configuration settings**

Press and release the Setpoint Up or Setpoint Down buttons.

### **To exit Keypad Configuration**

Keypad Configuration will end on its own 30 seconds after the last button press or when the MODE button on the Keypad is pressed.

### **Fahrenheit/ Celsius Display Switch:**

Change between degrees Fahrenheit and Celsius on the display. An “F” indicates Fahrenheit display and ‘C’ indicates Celsius. Default is degrees “F”.

### **Indoor Air Temperature Sensor Biasing for**

#### **Cooling mode:**

Sometimes known as an anticipator, the air temperature sensor bias is used to adjust the room air temperature reading when in cooling mode. (Not normally required.)

### **Indoor Air Temperature Sensor Biasing for**

#### **Heating mode:**

Sometimes known as an anticipator, the air temperature sensor bias is used to adjust the room air temperature reading when in heating mode. (Not normally required.)

### **Indoor Temperature Display:**

Change between showing setpoint only on the display during heating and cooling modes “SP” or displaying room temperature during heating and cooling modes “AA”. “SP” mode is the default mode.

- If “SP” is selected, only the setpoint will be displayed during heating and cooling modes, regardless of what the real temperature is in the room.
- If “AA” mode is selected, the room temperature will be displayed during heating, cooling and fan only modes.
  - If the mode button has been changed to either heating or cooling modes, setpoint will be displayed for 10 seconds. After the 10 seconds, the room temperature will again be displayed.
  - If the on/off button is depressed (when the unit is off) and the last mode was either cooling or heating mode, the setpoint will be displayed for 10 seconds before displaying room temperature.
  - During heating and cooling modes, if either the up or down setpoint key is depressed, the display will show the setpoint until 10 seconds after the last up or down key press. Then the room temperature will be displayed again.

## AUXILIARY CONTROLS

### WALL THERMOSTAT TERMINAL

**NOTE:** Carrier thermostats are recommended.

**IMPORTANT:** Only trained, qualified personnel should access electrical panel on unit and install electrical accessories. Please contact your local electrical contractor, dealer, or distributor for assistance.

#### Thermostat Wire Routing

Thermostat wire is field supplied. Recommended wire gauge is 18 to 20 gauge solid thermostat wire.

**NOTE:** It is recommended that extra wires are run to unit in case any are damaged during installation.

Thermostat wire should always be routed around or under, **NEVER** through, the wall sleeve. The wire should then be routed behind the front panel to the easily accessible terminal connector.

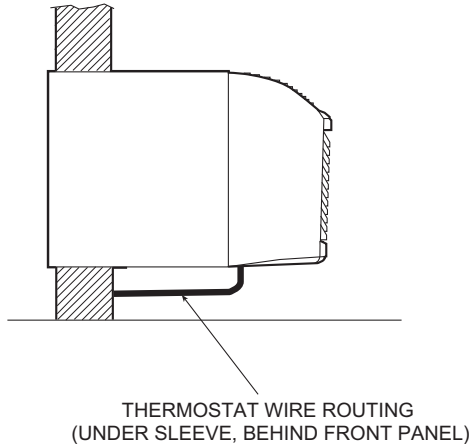

A07074

**Fig. 21 – Proper Wire Routing Beneath Unit**

#### Wiring Thermostat To Unit

Wire wall thermostat input as defined in Fig. 26.

**NOTE:** Terminal connector can be removed and replaced to simplify the wiring.

**NOTE:** For heat pump models, anytime there is a second-stage call for heating from the wall thermostat, the unit will automatically switch over to electric heating.

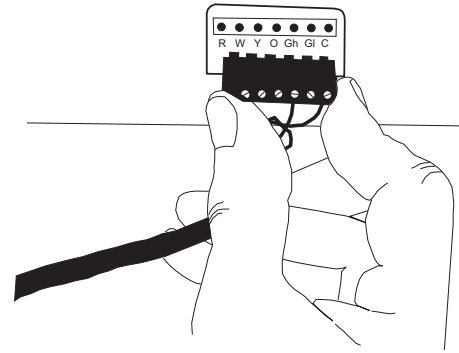

A07073

**Fig. 22 – Terminal Connector Removal and Replacement**

#### Install Thermostat Wiring

1. Check to be sure power to unit is disconnected.
2. Pull terminal connector to remove

**NOTE:** Terminal connector can be removed and replaced to simplify thermostat wiring.

3. Connect wires from the thermostat to terminals on unit terminal connector.
4. Reinstall terminal connector.
5. Ensure that unit is configured for wall thermostat enable.
6. Replace control panel label with wall thermostat label (included). See Fig. 24.
7. Restore power to unit.



A07315

**Fig. 23 – Wall Thermostat Control Panel Label**

**NOTE:** Refer to thermostat installation instructions for details on installing wall thermostat.

**NOTE:** For thermostats that have only one fan speed output (on or auto), the fan speed is determined by how the terminal connector is wired. If Low fan is desired, wire the G output from the thermostat to GL on the unit's terminal block. If Hi fan is desired, wire the G output from the thermostat to GH on the unit's terminal block.

**NOTE:** After proper installation, if your thermostat is not working properly, refer to the *Trouble Shooting* section.

## TERMINAL CONNECTIONS

The wall thermostat terminal block is located behind the front panel and is easily accessible on front of control panel.

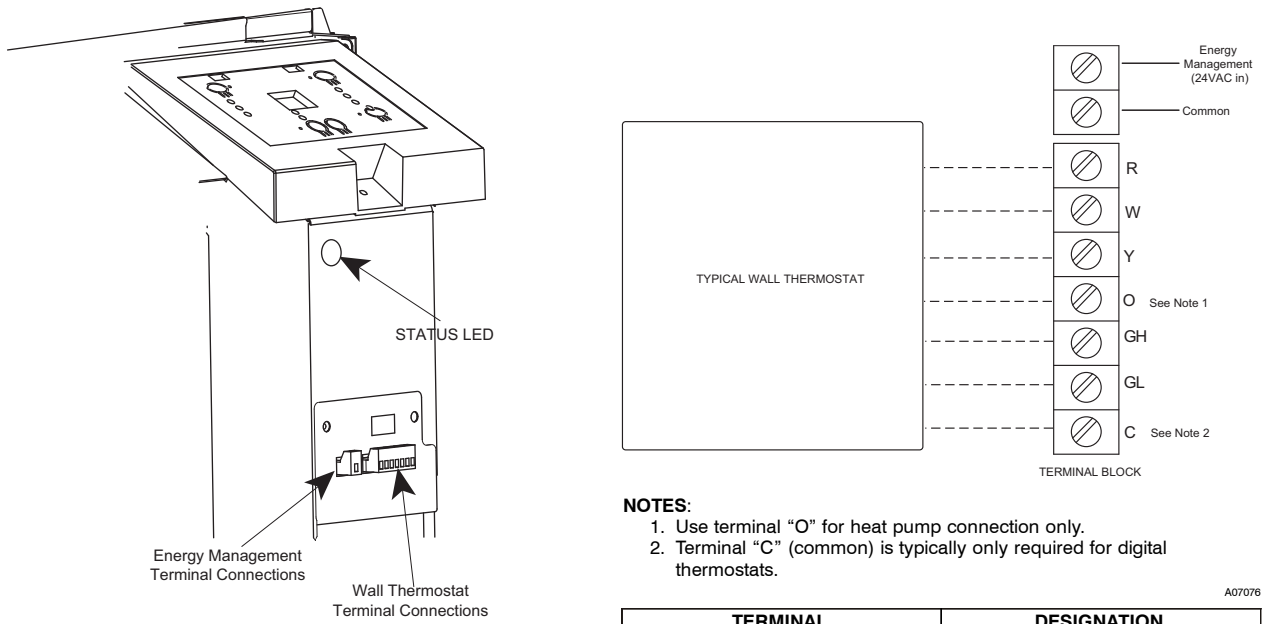

Fig. 24 – Terminal Connector and Status LED Location

**CAUTION**

**UNIT DAMAGE HAZARD**

Failure to follow this caution may result in equipment damage or improper operation.

Improper wiring may damage unit electronics. Common busing is not permitted. Damage or erratic operation may result.

- NOTES:**
1. Use terminal "O" for heat pump connection only.
  2. Terminal "C" (common) is typically only required for digital thermostats.

TERMINAL	DESIGNATION
R	24 VAC
W	Electric Heat
Y	Compressor
O	Reversing Valve
GH	High Fan
GL	Low Fan
C	Common

**NOTE:** Any illegal input combinations will be captured as thermostat wiring failures and will light the STATUS LED indicator on main board (see *Intelligent Self-Checking Control* section)

Fig. 25 – Wiring Connections

## ENERGY MANAGEMENT INPUT (FRONT DESK CONTROL)

The controller can handle a switch signal from remote energy management input, called EM signal or front desk control. Input must be 24VAC. If system receives a 24VAC signal, it will turn unit off; otherwise, the unit runs in normal control. This function will be disabled under Freeze Guard protection. See Fig. 25 and Fig. 26 for terminal connections.

## INTELLIGENT SELF-CHECKING CONTROL

Your Carrier PTAC has a computer board that continuously checks key components of the unit to ensure they are operating properly. Under normal operation, unit status indicator (STATUS, on main PCB), light is steadily ON. If there is a major problem, the unit will shut down and display a diagnostic failure code on the unit's display. If it is only a minor failure and unit is correcting the fault by itself, the diagnostic code will be flashed on the status LED that can easily be seen when the front panel is removed (see Fig. 25). Failure STATUS codes are defined in the table below

Table 6—STATUS LED Indicator Definitions

1	Indoor air temp sensor open/short	7-segment display 'F1', with STATUS light flash 1 time, off 2 seconds
2	Indoor coil sensor open/short	7-segment display 'F2', with STATUS light flash 2 time, off 2 seconds
3	Outdoor coil sensor open/short	7-segment display 'F4', with STATUS light flash 4 time, off 2 seconds
4	Freeze Guard protection	7-segment display 'FP'
5	Thermostat wiring error	STATUS light flash 9 times and off 3 sec, repeat
6	Indoor coil high temp protection	STATUS light flash 8 times and off 3 sec, repeat
7	Defrost (heat pump type)	STATUS light flash 7 times and off 3 sec, repeat
8	Outdoor coil high temp protection	STATUS light flash 6 times and off 3 sec, repeat
9	Indoor coil freeze protection	STATUS light flash 5 times and off 3 sec, repeat

**NOTE:** When status light is flashing, it will be ON for 0.5 seconds and OFF for another 0.5 seconds.

## OPERATION

**IMPORTANT:** When unit is first started, high humidity conditions can cause condensation to form on discharge grille. Keep doors and windows closed. Room humidity will decrease and moisture will evaporate.

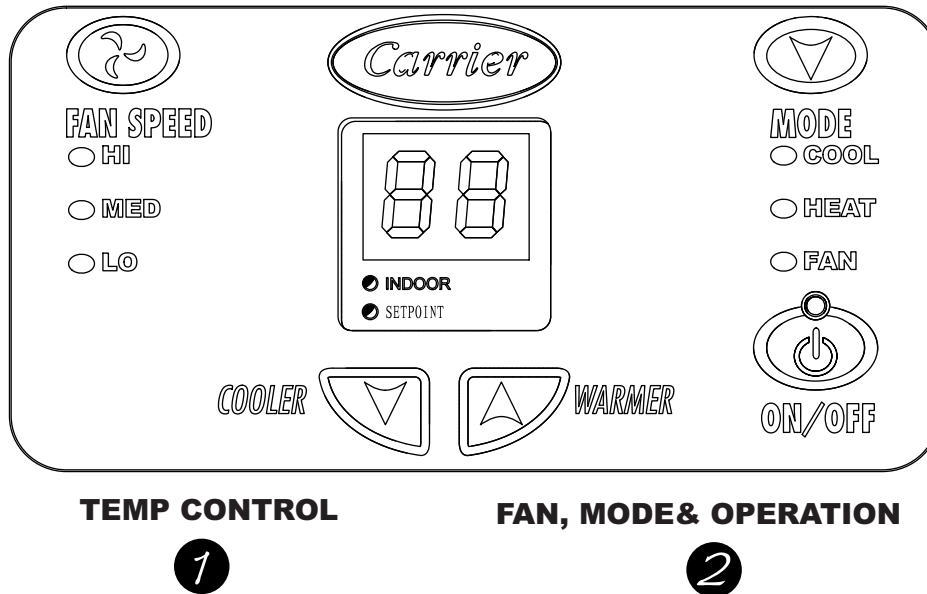

Fig. 26 – PTAC CONTROLS

A07061

## ABOUT THE CONTROLS ON YOUR UNIT

**NOTE:** In case of a power failure, the unit will remember the last programmed settings and will restart to those settings.

### 1. TEMP CONTROL

Temp Control is used to maintain room temperature. Compressor will cycle on and off to keep room at the requested level of comfort.

**COOLER** - Lowers temperature.  
(Minimum temperature setting is 61°F/16°C)

**WARMER** - Raises temperature.  
(Maximum temperature setting is 86°F/30°C)

### 2. FAN SPEED, MODE & ON/OFF

**FAN SPEED** - Set fan operation for **HI**, **MED**, or **LO** speed.

**MODE-COOL** - For cooling

**MODE-HEAT** - For heating

**NOTE:** If unit is a heat pump, raising the heat setting 5°F (2.8°C) will cause unit to use its electric heating elements for one cycle in order to reach the new requested temperature quickly.

**MODE-FAN** - For fan-only operation

**ON/OFF** - Turns the unit on or off.

**NOTE:** The LED above the ON/OFF button will be green when unit is ON and red when the unit is OFF. All other LEDs will be off when unit is set to OFF mode.

**NOTE:** Power remains connected to unit.



## CARE AND CLEANING

### FRONT PANEL AND CASE

Turn unit off and disconnect power supply.

To clean, use water and a mild detergent. **DO NOT** use bleach or abrasives. Some commercial cleaners may damage the plastic parts.

### OUTDOOR COIL

Coil on outdoor side of unit should be checked regularly. Unit will need to be removed to inspect dirt build-up that will occur on the inside of the coil. If clogged with dirt or soot, coil should be professionally cleaned.

**NOTE:** Never use a high-pressure spray on coil.

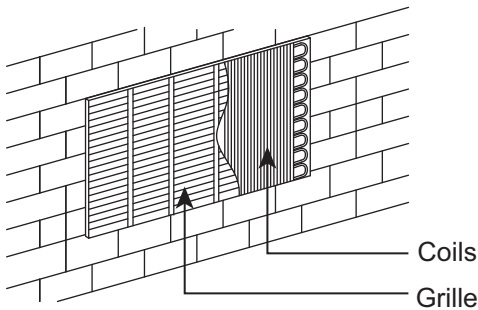

Clean inside and outside of outdoor coils regularly

Fig. 27 – Outdoor Coil

A07077

### AIR FILTERS

**IMPORTANT: TURN UNIT OFF BEFORE CLEANING**



## CAUTION

#### UNIT DAMAGE HAZARD

Failure to follow this caution may result in equipment damage or improper operation.

**Do not** operate unit without filters in place. If a filter becomes torn or damaged, it should be replaced immediately.

Operating without filters in place or with damaged filters will allow dirt and dust to reach indoor coil and reduce cooling, heating, airflow and efficiency of unit. Airflow restriction may cause damage to unit.

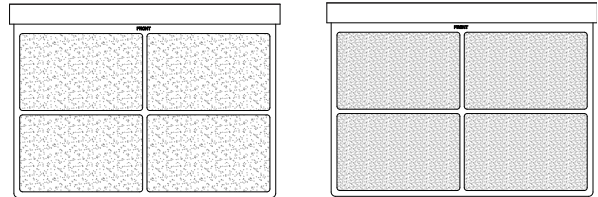

Dirty filter -  
Needs cleaning

Clogged filter -  
Greatly reduces cooling,  
heating and airflow.

A07078

Fig. 28 – Identifying Clogged Filter

The most important thing you can do to maintain unit efficiency is to clean the filters at least every 30 days (or sooner depending on application). Clogged filters reduce cooling, heating and airflow.

#### Keeping filters clean will:

- Decrease cost of operation.
- Save energy.
- Prevent clogged indoor coil.
- Reduce risk of premature component failure.

#### To Clean Air Filters:

- Vacuum off heavy soil.
- Run water through filters.
- Dry thoroughly before replacing.



## CAUTION

#### UNIT DAMAGE HAZARD

Failure to follow this caution may result in equipment damage or improper operation.

Airflow restriction may cause damage to the unit.

### BASE PAN

In some installations, dirt or other debris may be blown into unit from outside and settle in base pan (bottom of unit).

In some areas of the United States, a “jell-like” substance may be seen in the base pan. Check base pan periodically and clean, if necessary.

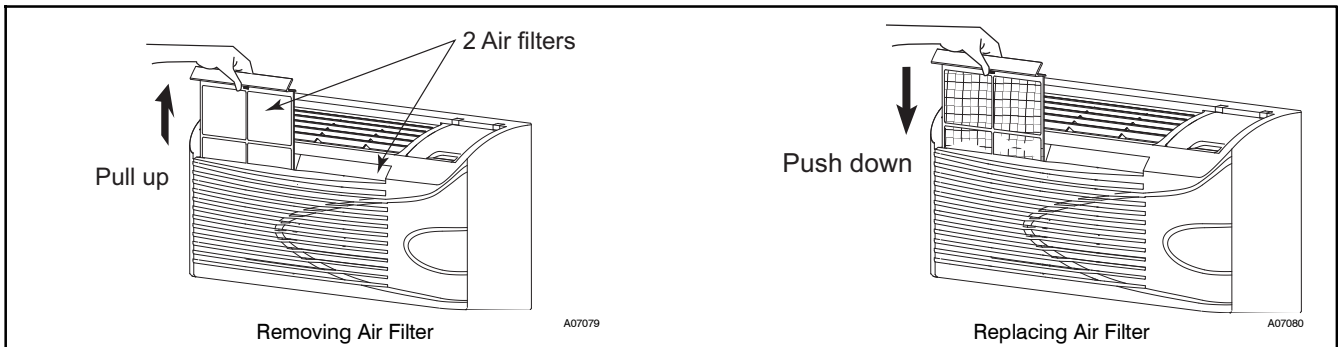

Removing Air Filter

A07079

Replacing Air Filter

A07080

Fig. 29 – Removing and Replacing Air Filter

## **PREVENTATIVE MAINTENANCE**

Preventative maintenance is essential to proper unit operation, efficiency and longevity.

To ensure equipment operates properly, it must be properly maintained. Equipment operation should be checked and verified several times during each year. During regular unit inspection and maintenance, follow the guidelines below:

- Clean both sides of outdoor coil. (Never use high pressure spray on coils.)
- Clean basepan and outdoor vent filter.
- Clean outdoor orifice and fan.
- Clean indoor coil. (Never use high pressure spray on coils.)
- Clean indoor fan, wire screen and front panel.
- Clean or install new indoor-air inlet filter(s).
- Clean wall sleeve and outdoor grille.
- Inspect cord and receptacle.
- Secure electrical connections.
- Ensure front panel is properly mounted and not damaged.
- Ensure wall sleeve is installed properly.
- Ensure heat and cool cycles operate properly.

# TROUBLESHOOTING

POSSIBLE CAUSES	SOLUTIONS
<p><b>UNIT DOES NOT START</b></p> <ul style="list-style-type: none"> <li>Unit may have become unplugged</li> <li>Fuse may have blown</li> <li>Circuit breaker may have been tripped</li> <li>Unit may be off or in wall thermostat mode. Check section on dipswitch settings to verify dipswitches are set properly.</li> <li>Unit may be in a protection or diagnostic failure mode. See section on Intelligent Self-checking Control.</li> </ul>	<ul style="list-style-type: none"> <li>Check that plug is plugged securely in wall receptacle. <b>Note</b> :Plug has a test/reset button on it. Make sure that the plug has not tripped.</li> <li>Replace the fuse. See Note 1.</li> <li>Reset circuit breaker. See Note 1.</li> <li>Turn unit on (bottom right button on keypad). <b>Note</b>: If the unit turns on, the LED will be green. If the unit is off, the LED will be red. If there is no LED on, there is a problem with power or damage to the control.</li> </ul>
<p><b>UNIT NOT COOLING/HEATING ROOM</b></p> <ul style="list-style-type: none"> <li>Unit air discharge section is blocked</li> <li>Temperature setting is not high or low enough <b>Note</b>: Setpoint limits may not allow the unit to heat or cool the room to the temperature desired. Check section on dipswitch settings.</li> <li>Unit air filters are dirty.</li> <li>Room is excessively hot or cold when unit is started.</li> <li>Vent door left open</li> <li>Unit may be in a protection or diagnostic failure mode. Check section on Intelligent Self-checking Control.</li> <li>Compressor is in time delay. There is a protective time delay (approx. 3 minutes) on starting the compressor after a power outage (or restarting after it has been turned off), to prevent tripping of the compressor overload.</li> </ul>	<ul style="list-style-type: none"> <li>Make sure that curtains, blinds or furniture are not restricting or blocking unit airflow.</li> <li>Reset to a lower or higher temperature setting.</li> <li>Remove and clean filters.</li> <li>Allow sufficient amount of time for unit to heat or cool the room. Start heating or cooling early before outdoor temperature, cooking heat or gatherings of people make room uncomfortable.</li> <li>Close vent door.</li> <li>Check dipswitch settings for desired comfort.</li> </ul> <p>Wait approximately 3 minutes for compressor to start</p>
<p><b>DISPLAY HAS STRANGE NUMBERS/CHARACTERS ON IT</b></p>	<ul style="list-style-type: none"> <li>The unit may be in a diagnostic condition. Check Intelligent Self-checking Control section to determine if unit has had a failure.</li> <li>The unit may be set for °C (instead of °F), see the keypad configuration section</li> </ul>
<p><b>UNIT MAKING NOISES</b></p>	<ul style="list-style-type: none"> <li>Clicking, gurgling and whooshing noises are normal during operation of unit.</li> </ul>
<p><b>WATER DRIPPING OUTSIDE</b></p>	<ul style="list-style-type: none"> <li>If a drain kit has not been installed, condensation runoff during very hot and humid weather is normal. See Note 2. If a drain kit has been installed and is connected to a drain system, check gaskets and fittings around drain for leaks and plugs.</li> </ul>
<p><b>WATER DRIPPING INSIDE</b></p> <ul style="list-style-type: none"> <li>Wall sleeve is not installed level</li> </ul>	<ul style="list-style-type: none"> <li>Wall sleeve must be installed level for proper drainage of condensation. Check that installation is level and make any necessary adjustments.</li> </ul>
<p><b>ICE OR FROST FORMS ON INDOOR COIL</b></p> <ul style="list-style-type: none"> <li>Low outdoor temperature</li> <li>Dirty filters</li> </ul>	<ul style="list-style-type: none"> <li>When outdoor temperature is approximately 55°F (12.8°C) or below, frost may form on the indoor coil when unit is in Cooling mode. Switch unit to FAN operation until ice or frost melts.</li> <li>Remove and clean filters.</li> </ul>
<p><b>COMPRESSOR PROTECTION</b></p> <ul style="list-style-type: none"> <li>Power may have cycled, so compressor is in a restart protection.</li> </ul>	<ul style="list-style-type: none"> <li><b>Random Compressor restart</b> – Whenever the unit is plugged in, or power has been restarted, a random compressor restart will occur. After a power outage, the compressor will restart after approximately 3 minutes.</li> <li><b>Compressor Protection</b> – To prevent short cycling of the compressor, there is a random startup delay of 3 minutes and a minimum compressor run time of 3 minutes.</li> </ul>

**NOTES:**

- If circuit breaker is tripped or fuse is blown more than once, contact a qualified electrician.
- If unit is installed where condensation drainage could drip in an undesirable location, an accessory drain kit should be installed and connected to drain system.

## NOTES

---

## NOTES

---

## NOTES

---

# Carrier Packaged Terminal Air Conditioner Limited Warranty

**FIRST YEAR PARTS AND LABOR LIMITED WARRANTY** – During the first year after purchase, CARRIER will, through its authorized independent servicing dealer or service stations\*, and free of charge to the user or subsequent users, repair or replace any parts that fail due to defect in material or workmanship. The replacement part can be a new or remanufactured part as provided at CARRIER'S sole option.

**EXTENDED FOUR-YEAR PARTS AND LABOR LIMITED WARRANTY ON SEALED REFRIGERATION SYSTEM ONLY** – During the second through fifth years after date of original purchase, CARRIER will, through its authorized servicing dealers and service stations\* and free of charge to the end user or subsequent users, repair or replace the compressor, condenser, evaporator or connecting tubing if it failed due to defect in material or workmanship. This includes system refrigeration charge. The replacement part can be new or a remanufactured part at CARRIER'S sole option.

**EXTENDED FOUR-YEAR PARTS ONLY LIMITED WARRANTY ON NON-SEALED REFRIGERATION SYSTEM ONLY** – During the second through fifth years after date of original purchase, Carrier will, through its authorized servicing dealers and service stations and free of charge to the end user or subsequent users, repair or replace any non-sealed system part (motor, solenoid, thermostat, relay, switch, capacitor, overload, drain valve, bulb heater, fan, stator) if failed due to defect in material or workmanship. The replacement part can be new or a remanufactured part at CARRIER'S sole option. THIS LIMITED WARRANTY DOES NOT INCLUDE LABOR, user is responsible for labor, including cost of diagnosis of problem, removal and transportation of the air conditioner to and from the service center, and reinstallation charges necessary to accomplish repair.

**LIMITATION OF WARRANTIES** – ALL IMPLIED WARRANTIES (INCLUDING IMPLIED WARRANTIES OF MERCHANTABILITY AND FITNESS FOR PARTICULAR USE OR PURPOSE) ARE HEREBY LIMITED IN DURATION TO THE PERIOD FOR WHICH EACH LIMITED WARRANTY IS GIVEN AND APPLIES. SOME STATES DO NOT ALLOW LIMITATIONS ON HOW LONG AN IMPLIED WARRANTY LASTS, SO THE ABOVE LIMITATION MAY NOT APPLY TO YOU. THE EXPRESSED WARRANTIES MADE IN THIS WARRANTY ARE EXCLUSIVE AND MAY NOT BE ALTERED, ENLARGED, OR CHANGED BY ANY DISTRIBUTOR, DEALER, OR OTHER PERSON WHATSOEVER.

ALL WORK UNDER THE TERMS OF THIS WARRANTY SHALL BE PERFORMED DURING NORMAL WORKING HOURS. ALL REPLACEMENT PARTS, WHETHER NEW OR REMANUFACTURED, ASSUME AS THEIR WARRANTY PERIOD ONLY THE REMAINING TIME PERIOD OF THIS WARRANTY.

\*Authorized independent dealers or service stations are registered with Carrier through its distributor organization.

**This warranty gives you specific legal rights, and you may also have other rights which vary from state to state.**

## CARRIER WILL NOT BE RESPONSIBLE FOR:

- CLEANING REQUIRED PRIOR TO WARRANTY REPAIR.**  
Standard maintenance, cleaning or damage resulting from failure to perform normal maintenance as outlined in the owner's manual.
- Instruction on methods of control and use of air conditioning unit after initial installation.
- Damage or repairs needed as consequence of faulty installation or application. This is the responsibility of the installer.
- Failure to start due to voltage conditions, blown fuses, open circuit breakers or any other damages due to the inadequacy or interruption of electrical services.
- Damage or repairs needed as consequence of any misapplication, abuse, unauthorized alteration, improper servicing or operation.
- Damage as a result of floods, winds, fires, lightning, accidents, corrosive environment, or other conditions beyond the control of CARRIER.  
**EXCEPTION TO CORROSIVE ENVIRONMENT EXCLUSION IN ABOVE PARAGRAPH** – Packed terminal units (52 Series) built with corrosion protection are exempt from the exclusion – "Corrosive Environment." The unit model number is identified on the nameplate with CP suffix.
- Reimbursement for replacement parts or repair services which are not supplied or designated by CARRIER and which are specifically covered under this warranty.
- CARRIER products installed outside the continental U.S.A., Alaska, Hawaii, and Canada.
- Shipping damage or damage as a result of transporting the unit. This is the responsibility of the selling dealer or the authorized Room Air Conditioner service station.
- ANY SPECIAL, INDIRECT OR CONSEQUENTIAL PROPERTY OR COMMERCIAL DAMAGE OF ANY NATURE WHATSOEVER. Some states do not allow the exclusion or limitation of incidental or consequential damages, so the above limitation or exclusion may not apply to you.
- Warranty coverage of accessory items (wall thermostats, wall sleeves, etc.)

**NOTE:** Service and Maintenance items excluded in this warranty may be covered by a separate service agreement through the seller at time of purchase.

# Carrier Corporation

## IF YOUR AIR CONDITIONER DOES NOT WORK, FOLLOW THESE STEPS IN ORDER:

1. **CHECK THE THINGS YOU CAN DO YOURSELF.** These include being sure the air conditioner is plugged in firmly in an appropriate receptacle, checking the fuse or circuit breaker and ensuring its replacement or resetting, if necessary, and rereading the instruction book to ensure that all controls are set properly. By doing this you can save money. Many unnecessary service calls result in the serviceman doing what the owner can do for him or herself.
2. **CONTACT YOUR DEALER OR THE CARRIER AUTHORIZED SERVICE CENTER HE RECOMMENDS.** They have been set up to handle the great majority of all possible service problems. The quickest, surest and best way to get your air conditioner back in service is to use this step before proceeding further.
3. **CONTACT THE CARRIER DISTRIBUTOR SERVING YOUR AREA.** Your dealer can give you his name or you can consult your yellow pages.
4. **CONTACT CARRIER IF A SATISFACTORY SOLUTION IS NOT REACHED IN STEPS 2 AND 3.**

Carrier Corporation  
Consumer Relations Department  
Carrier Parkway, P.O. Box 4808  
Syracuse, New York 13221  
Telephone: 1-800-894-6449

Catalog Number: 49004DP58

Edition Date: 08/07